

300 Hz HIGHPASS FILTER

This filter is from the TI Filter Designer.  
 Parameters:  
 High Pass  
 Poles = 4  
 Fc = 300 Hz  
 MFB  
 Linear Phase  
 0.05 degree  
 Gain = 1

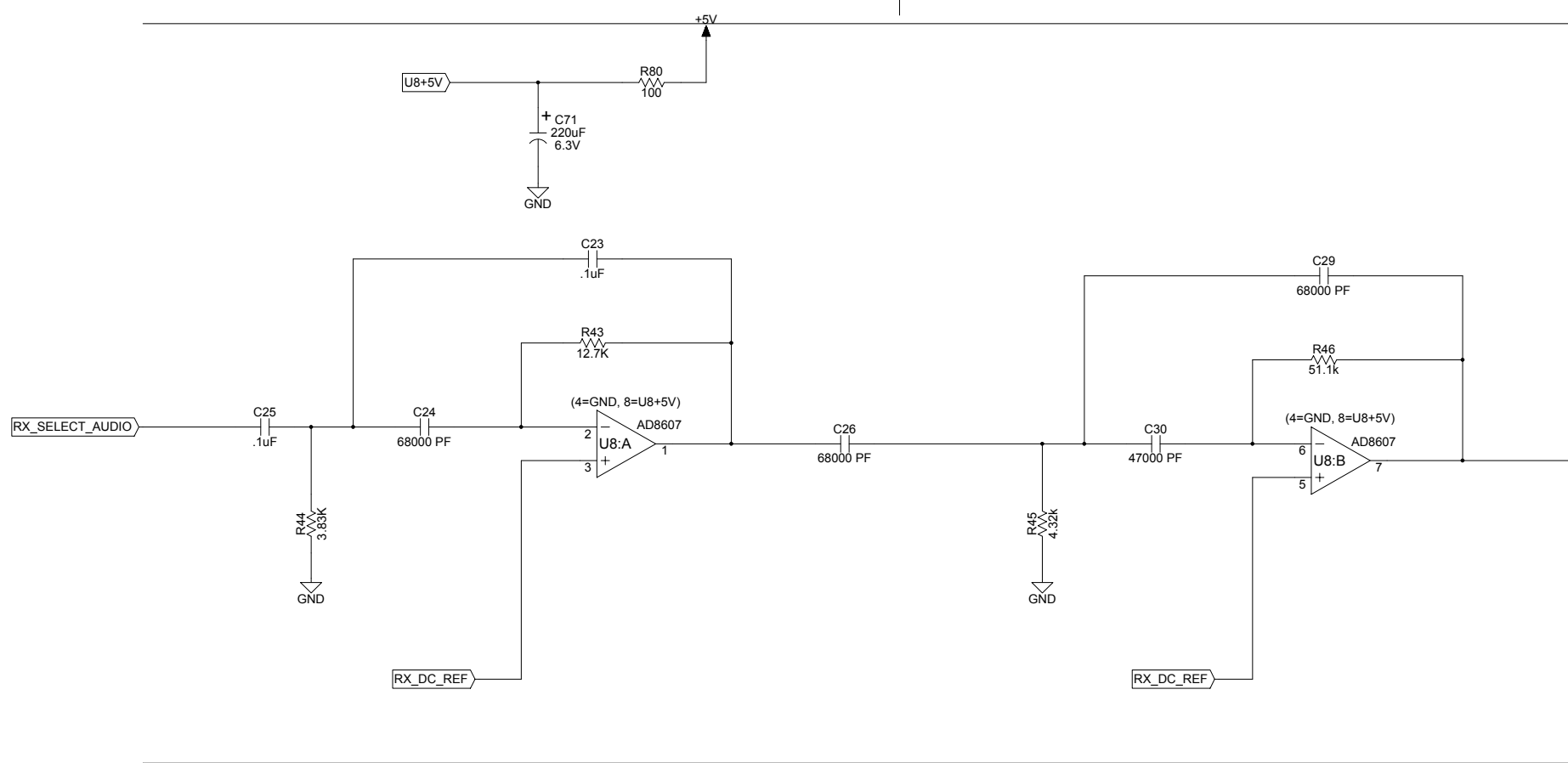

This filter is from the TI Filter Designer.  
 Parameters:  
 Low Pass  
 Poles = 8  
 MFB  
 Fc = 2400Hz  
 Linear Phase  
 0.05 degrees  
 Gain = 1

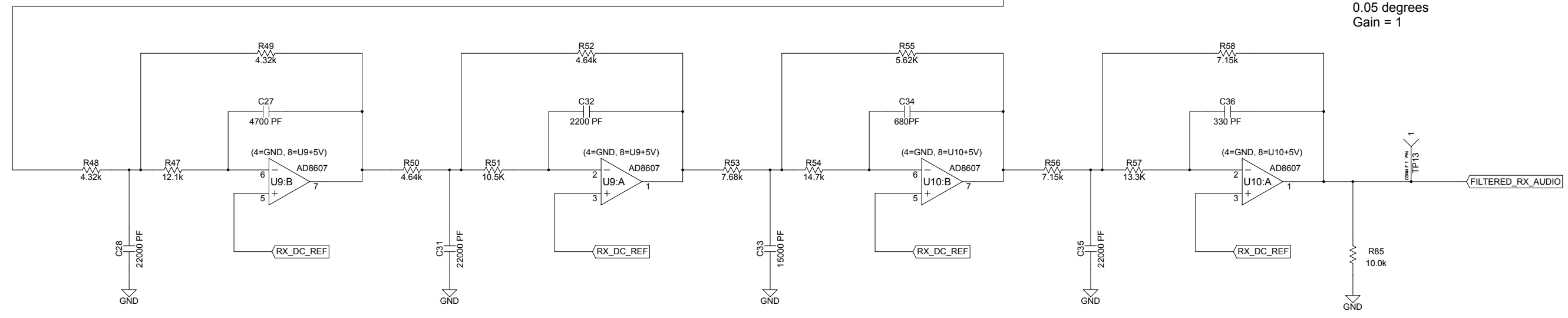

2400 HZ LOW PASS FILTER

Title RCVR Audio Filtering		
Size D	Number	Rev 0
Date 02 APR 06	Drawn by PAlexander	
Filename	Sheet 3	of 5