

INSTRUCTION MANUAL

DOVETRON MPC-1000C

MULTIPATH-DIVERSITY RTTY TERMINAL UNIT

E - SERIES

THE CONTENTS OF THIS MANUAL AND THE ATTACHED PRINTS ARE PROPRIETARY TO DOVETRON AND ARE PROVIDED FOR THE USER'S CONVENIENCE ONLY. NO PERMISSION, EXPRESSED OR IMPLIED, IS GIVEN FOR COMMERCIAL EXPLOITATION OF THE CONTENTS OF THIS MANUAL AND/OR THE ATTACHED PRINTS AND DRAWINGS.

DOVETRON † 627 Fremont Avenue
So. Pasadena, California, 91030
† P O Box 267 †† 213-682-3705 †

MPC-1000C.300 and up.

Issue 5
January 1978

CONTENTS

	PREFACE	
I	OPERATING HINTS	1
II	INSTALLATION INSTRUCTIONS	2
III	GENERAL DESCRIPTION	4
IV	SPECIFICATIONS	6
V	THEORY OF OPERATION	8
VI	CIRCUIT DESCRIPTIONS	10
VII	BLOCK DIAGRAMS	23
VIII	REGENERATION INTERFACE	29
IX	CALIBRATION PROCEDURES	30
X	VARIABLE FEATURES	33
XI	SERVICE INSTRUCTIONS	38
XII	TEST PROCEDURE & TROUBLE SHOOTING	42
XIII	TROUBLE SHOOTING HINTS	49
XIV	SPARE PARTS INFORMATION	50
XV	RECOMMENDED SPARES & PROVISIONING	51
XVI	PARTS LIST	52
XVII	WARRANTY - NON-WARRANTY REPAIR	57
XVIII	NOTES	58

THIS MANUAL IS COMPLETE WHEN SCHEMATIC DIAGRAM 75103E AND COMPONENT LOCATION PRINT 75100E ARE ATTACHED.

PREFACE

Many schemes have been presented to improve the performance of RTTY Terminal Units in the presence of the anomalies of HF (3 to 30 MHz) radio propagation.

Most of them, with esoteric sounding names, like Automatic Threshold Corrector, Decision Threshold Computer, Axis Restorers, Hard Limiters and the like, addressed themselves to the problems of fading and noise.

It was reasoned that an FM discriminator with hard limiting would overcome the problems of AM noise pulses and fading. To a large extent, these designs were successful.

But too often, signals could still be heard, or seen in the various display units, and no copy could be had on the teleprinter.

Ingenious circuits were devised that doubled (or quadrupled) the redundancy of the Baudot Code, and large capital investments were made in dual receiving installations that permitted Dual-Diversity operation, where two antennas, two receivers, and two terminal units with a combiner were used to drive a single teleprinter.

This approach certainly works better, as evidenced by the many Dual (polarization, frequency and space) Diversity systems in use today.

But little work was done in the area of In-Band Diversity, where the Mark and Space signals being transmitted by a single transmitter are received and treated as two independent AM stations operating a few hundred Hertz apart, both containing precisely the same information at the same time.

Systems that attempted such an AM Diversity approach, often called TTL, Two Tone Limiterless, usually ended up with a hard limiter to prevent hits from fast fades of the long marking pulses between the characters of keyboard signals.

Realizing that almost all terminal unit designs were adequate when operating with good signals, Dovetron initiated a program in 1971 to develop a terminal unit that would offer the best of both worlds: FM and its hard limiting, and Linear AM with its benefits of In-Band Diversity.

With the development of the AMTI-MARK/FADE circuit, it was possible to have all the advantages of AM Limiterless operation, taking full benefit of the independent action of the Mark and Space tone channels, and at the same time, not taking hits at slow keyboard speeds.

But it became obvious very early that another phenomena was present: Time and Frequency Dispersion of both the Mark and Space channels, i.e., Multipath Distortion.

Unlike Selective Fading, which is also a form of Multipath Distortion, the phenomena stretched and smeared the pulses in time and modulated each in frequency.

Dual trace oscilloscope analysis (using the computer designed Bessel Function filters in the Dovetron prototype) revealed that the information was there, but not in a form that a conventional FM terminal unit could copy.

Often considered a night-time phenomena on the lower frequencies, Multipath Distortion was also discovered to be present during the daylight hours on almost all signal paths in the HF spectrum. Conjecture led to the belief that this phenomena was probably caused by simultaneous auroral and/or equatorial side paths. The design goal was not to discover why it existed, but rather how to cope with it and demodulate the information available with the lowest possible error rate.

So in addition to designing a terminal unit that took advantage of selective fading as caused by Multipath Propagation, a design effort was made to cope with the smear and overlap of the alternating Mark and Space pulses.

The problem became more complex when it was determined that the strongest channel was not necessarily the wanted channel. The term MULTIPATH CORRECTORTM was coined and Dovetron set out to develop one.

Many versions of Multipath Correction were developed. Some of them worked quite well. Some were very simple and others were very complicated. Some were asynchronous and had to be clocked at the incoming Baud rate, and others ran in an independent synchronous mode.

It was finally determined that a simpler asynchronous approach was feasible, was easy to manufacture, required no maintenance or adjustment, and produced the desired results.

Rather than quote error rate differentials, it is just simpler to say that if it can't be copied on the Dovetron MPC Series, it probably can't be copied.

To permit the MULTIPATH CORRECTOR™ to function properly, it was necessary to demodulate the Mark and Space channels without adding any significant perturbations. This was done with two identical VLF receivers, one tuned to the Mark frequency and the other tuned to the Space frequency. Their identicalness assured that any distortions or timing errors added to one channel would be added to the other in a like amount.

It worked. Multipath Correction became a reality without sacrificing the high performance of the Linear AM circuits.

The two identical receivers were incorporated into a single package with a common power supply. A CRT Cross Display was added for ease of tuning. Peripheral non-data circuits were added, and the Dovetron MPC-1000C became a finished product.

Needless to say, acceptance was immediate.

As feedback was collected from users in the field, additional features were incorporated into the design.

The culmination of this effort was realized with the sixth generation. Its designation is: E Series.

We sincerely hope you enjoy the performance of the E Series MPC-1000C as much as we enjoyed developing it.

DOVETRON

SECTION I

OPERATING HINTS

For the operator who prefers to turn on a new piece of equipment and read the manual later, the following is offered:

- 1) Attach power cord, teleprinter's loop line and audio line from receiver.
- 2) Set LOOP adjustment potentiometer on rear panel to full counter clockwise position (MIN).
- 3) Place all front panel toggle switches UP.
- 4) Set the LEVEL control at 9 o'clock.
- 5) Set the THRESHOLD control at 12 o'clock.
- 6) Set Mode switch to MS, which is the normal Mark-Space In-Band Diversity position.
- 7) Adjust Mark VFO to 2125 Hz.
- 8) Adjust Space VFO to desired space tone frequency:
2295 Hz. for 170 Hz. shift.
2975 Hz. for 350 Hz. shift.
2550 Hz. is the proper space tone for 425 Hz. commercial shift.
- 9) Tune in a RTTY signal and start copying.
- 10) If garbled, reverse NORMAL/REVERSE switch.
- 11) Now sit back and read the rest of this manual and discover all the other things that the MPC-1000(C) can do.

If after reading the manual and studying the prints, should problems or questions persist, contact DOVETRON at 627 Fremont Avenue, South Pasadena, California, 91030, or call: 213-682-3705.

SECTION II

INSTALLATION INSTRUCTIONS

1. Observe the power-main requirements as marked on the rear panel just below the AC power cord receptacle.

The MPC-1000C may be internally strapped for 110 VAC or 220 VAC operation from single phase, 50 to 400 Hz power mains.

To change the AC input voltage range, remove the top and bottom covers and locate the voltage selection jumpers next to the wire leads of the power transformer. Two jumpers are required for 110 volt operation. Only one lead is required in the middle jumper holes for 220 volt operation.

2. A three-conductor power cord is supplied with the MPC-1000C. The third conductor in this cord should be connected to a good earth ground, both for safety and for high performance of the terminal unit.
3. The neutral high level (120 volt DC, 60 Ma.) output has its own internal loop supply. Do not attempt to use a teleprinter that has a wired-in internal loop supply. The loop supply is adjustable over the range of 40 to 70 milliamperes, and is fused at the rear panel with a 0.1 ampere fast blow fuse.
4. Connect the MPC-1000C to the power mains and connect teleprinter to appropriate high level loop jack or low level FSK output connector. Standard 2-way plugs will work in either loop jack, but a 3-way jack is provided should the teleprinter be wired with a tip/ring type plug.
5. Turn the MPC-1000C ON and observe that the front panel LOOP LED indicator is lit, indicating that the TU is turned on and that at least 50 Ma. of loop current is flowing thru the teleprinter.
6. If Autostart operation is desired, plug the power cord from the teleprinter's motor into the PRINTER power connector on the rear panel of the TU, place MOTOR switch in AUTOSTART and select either MARK or FSK Autostart control.

7. Place the mode switch in the MS-REV position. Teleprinter should print a continuous string of RYs. If not, consult SECTION VI (MODE SWITCH) and SECTION IX (RY GENERATOR).
8. Switch the mode switch to MS (Mark-Space Diversity) and connect audio input line from receiver to audio input connector on rear panel.

The MPC-1000C has a balanced and isolated 600 Ω input matching transformer and should be driven by a 500 to 600 Ω line for best performance. An unbalanced line may be used. The input impedance of the primary of this audio transformer may be changed to values lower than 600 Ω if required. Please refer to the LEVEL CONTROL portion of Section VI.

9. The MPC-1000C is now set up for basic operation and the additional front panel controls are self explanatory.

SECTION III

GENERAL DESCRIPTION

The DOVETRON MPC-1000C Multipath-Diversity RTTY Terminal Unit is basically two identical low-frequency, single-conversion, solid-state receivers, whose outputs drive a MULTIPATH CORRECTOR™ circuit, which in turn, drives a high level keyer that outputs directly to a teleprinter.

Internal calibration adjustments permit the front panel VFOs to cover any 1900 Hz. segment between 100 Hz. and 4000 Hz.

An integral 2 inch CRT cross display indicates the Mark tone as a horizontal trace and the Space tone as a vertical trace. The selectivity of the channel filters and the scope amplifiers is such that time and frequency dispersions are readily apparent on the screen of the CRT.

The IN-BAND DIVERSITY mode of operation is automatic and single-channel (Mark-only or Space-only) copy is possible when one channel is lost due to deep selective fading or MAB (Make and Break) transmission modes as used in some satellite repeater operations.

In addition to Automatic Mark-Hold, Anti-Space and Anti-CW functions, the MPC-1000C also incorporates an ANTI-MARK-FADE (AMF) circuit that prevents false start pulses being generated by fast fades of the Marking pulse during slow speed (keyboard) operation.

A dual autostart circuit permits operator selection of auto-starting on a Marking carrier or on a signal with Mark-Space transitions. Neither mode responds to a continuous or keyed spacing carrier. The Mark mode does not respond to a spacing carrier, keyed or continuous.

Additional features provide for an external scope, external regeneration and code conversion, as well as diversity operation of two or more MPC-1000C terminal units without the use of a separate diversity combiner. The IN-BAND DIVERSITY capability of the MPC-1000C provides quad-diversity performance with only two terminal units, two receivers and two antennas.

The MULTIPATH-CORRECTOR™ circuit is an asynchronous regenerator that restores the proper Mark-Space transition points on RTTY signals that have been stretched or smeared by HF multipath propagation.

Capable of operating in excess of 50,000 baud, and taking its timing from the incoming signal, the MULTIPATH CORRECTOR™ circuit requires no internal or external clocks. No adjustments are required when changing speed.

Additional features include an internal high level loop supply (120 volts DC at .060 amps), two low level FSK voltage level outputs (EIA RS-232C and MIL STD 188C), and a phase-continuous sine-wave AFSK tone generator with an output of 60 Mv, peak to peak.

The Mark and Space tones of the AFSK tone generator are independently adjustable at the rear panel over the range of 1200 Hz. to 3100 Hz.

Other features include a front panel LED Signal Loss Indicator, remote controls for transmit, receive and standby functions, a LOCK line on transmit and two high level keyer output jacks.

The Signal Loss circuit is also buffered to the rear panel and may be used for system control or alarm circuits.

A proprietary Multipath Combiner circuit provides fully automatic operation of the MULTIPATH CORRECTOR™ under multipath signal conditions, as well as correlation and cancellation of noise.

Provision has also been made for the attachment of UART peripherals.

Normally wired for 110 volts, 40 Hz. to 400 Hz., single phase, simple internal jumper changes provide 220 volt operation.

Package size is 17" wide, 3.5" high and 9" deep. The cabinet is available in either a table-top or standard EIA 19" rack mounting configuration. Either unit weighs 11 pounds.

SECTION IV

SPECIFICATIONS

INPUT IMPEDANCE: 600 Ω , balanced and isolated. Adjustable to lower impedances.

INPUT LEVEL: 1 volt RMS Nominal. Useable from 5 millivolts to 25 volts RMS.

INPUT RATE: 45 to 75 baud. Field adjustable to other baud rates.

MARK-SPACE TONE FREQUENCIES: Variable from 1200 to 3100 Hz. with calibration points at 1275, 1360, 1445, 1575, 1700, 1870, 2000, 2125, 2295, 2425, 2550, 2775 and 2975 Hz.

OUTPUT CIRCUITS: High level solid-state neutral keyer with internal 120 volt DC loop supply. Current selectable and adjustable for 20, 40 and 60 mil operation.

Polar Keyer (PKC-100) option provides ± 60 VDC at 20 mils. Current range adjustable .

EIA RS-232C FSK voltage levels, 1K Ω output Z. Mark: -12vdc. Space: +12vdc.

MIL-STD-188C FSK voltage levels, 1K Ω output Z. Mark: +6vdc. Space: -6vdc.

Phase continuous, sine-wave AFSK tone generator. Output level: 60 millivolts with 470 Ω output Z. Tones independently adjustable at rear panel from 1200 Hz. to 3100 Hz. Balanced and isolated output option available.

Ext. scope connectors for dual-trace signal *analysis*.

Ext. connectors for regeneration, code conversion, crypto and speed changing peripherals.

Ext. connectors for dual-diversity use of two or more MPC-1000C terminal units without the need for an external diversity combiner.

Power connector for teleprinter's motor for autostart operation.

POWER REQUIREMENTS: 100 to 130 VAC or 200 to 260 VAC, internally selectable, 40 to 400 Hz., single phase, 25 watts.

POWER CORD: Standard detachable three-wire polarized cord.

TEMPERATURE RANGE: Operating: 0°C to 50°C.
Storage: -55°C to +165°C.

PHYSICAL DESCRIPTION

DIMENSIONS: Table-top: 17" wide, 3.5" high and 9" deep.
Rackmount: 19" wide, 3.5" high and 9" deep.

WEIGHT: 11 pounds operating.

SERVICING: The top and bottom covers are removable for maintenance. All internal adjustments are available from the top.

MAINTENANCE: Scheduled maintenance required: None.

KNOBS: Black insulated plastic.

RACKMOUNT: Standard EIA with mounting holds on 3.0" centers.

SECTION V

THEORY OF OPERATION

The MPC Series RTTY Terminal Units consist of two identical VLF (Very Low Frequency) AM superheterodyne receivers, in which the IF filters are analogous to the channel filters (Mark and Space) in conventional terminal units.

These Bessel Function, 3 section channel filters are identical in all respects including center frequency (750 Hz). The incoming Mark and Space tones are heterodyned into them thru full-wave J-Fet mixers. In this way, both channels are subjected to the same amount of group delay, transient response and other anomalies, thus maintaining the signal information in the same form for eventual processing.

The CRT Cross Display derives its information from the final stage of the channel filters and faithfully reproduces the actual signal content of the filters.

The Precision Detectors utilize active IC components which prevent thresholding effects and are also identical with the single exception that they are of opposite polarity. This opposite polarity of the detected Mark and Space channels permits noise cancellation at the input of the Multipath Combiner circuit.

In addition, the Multipath Combiner circuit permits automatic implementation of the MULTIPATH CORRECTORTM in the presence of Time and Frequency Dispersion of the RTTY signals by multipath propagation. It also provides a third channel of combined Mark-Space information that is used to operate the peripheral circuits for Automatic Mark/Hold, Anti-Space, Anti-CW, Anti-Mark/Fade, and Autostart.

The Low Pass Filters are also identical, and maintain the same timing between the Mark and Space channels. Their Bessel Function design provides a "flysheel" action that aids in overcoming the error-producing perturbations normally created by fast fades and noise transients. The bandwidth of the terminal unit is controlled by these Low Pass Filters and they are designed for 45 to 75 Baud operation. They are field-changeable for higher baud rates.

After the Low Pass Filters, the Mark and Space channels are processed thru separate AC coupled Assessor circuits, whose function is to establish the proper threshold level for each channel. It is this action that permits the TU to automatically copy from a single channel: IN-BAND DIVERSITY. This feature also permits one of the channels to be inhibited by the front panel mode switch for MAB (Make and Break) operation.

The outputs of the Assessors are fed to individual Slicers, where the binary decision is made, each channel still containing all of its original information, including overlap and smear.

The binary information is now entered into the MULTIPATH CORRECTORTM which acts as a regenerator and restores the proper zero crossings and presents the final composite binary signal to the low level and high level keyer stages.

Peripheral circuits provide automatic CRT intensity control, keyboard actuated autostart, signal loss alarm and dual-diversity comparison.

A front panel photocell connected across the Intensity control of the CRT provides high intensity in a high light environment and automatically reduces the CRT's intensity in a low light environment.

Keyboard Actuated Autostart permits the local teleprinter's motor to be turned on by pressing the Break button on the local keyboard.

The Signal Loss Circuit lights a front panel LED whenever the terminal unit goes to Automatic Mark-Hold and no signal is present in the Mark channel. A change of state is also applied to a rear panel connector for remote alarm purposes, etc.

Both the Mark and Space Precision Detector circuits contain a comparator input permitting two or more Dovetron terminal units to be used in a diversity configuration.

SECTION VI

CIRCUIT DESCRIPTIONS

LEVEL CONTROL

The LEVEL control (R172) on the front panel is an attenuator that is used to set the audio input to the terminal unit at a convenient level after the desired audio level of the companion receiver has been selected.

Location R172A is provided to permit padding of the impedance of the LEVEL control to a lower value, effectively lowering the input impedance of an audio input transformer. As an example, the input impedance of the 600 Ω input transformer in the MPC-1000C may be reduced to 450 ohms by installing a 5000 ohm, 1/4 watt, 5% resistor at location R172A.

INPUT IMPEDANCE

The input impedance of the MPC-1000C is an isolated and balanced 600 ohms. Transformer coupling is used to assure high common mode rejection over long lines associated with communication centers. It may be used with unbalanced lines.

INPUT AMPLIFIER

The input amplifier Z2 is AC coupled from the output of the Level pot R172, and is protected from voltage transients by a pair of back-biased diodes. This input may be driven to 50 volts without damage to the diodes or Z2. The gain of the input amplifier is adjustable by a PC board pot (R1) over a range of 2.5 to 50. This pot is nominally set at midscale for a gain of 25, and may be increased or decreased as needed.

The output of this amplifier drives one input of a full wave mixer in each channel and a unity gain inverter (Z3), which, in turn, drives the other input of the full wave mixer in each channel.

MIXER STAGES

Each Mixer consists of a pair of J-Fet transistors. Q1 and Q2 drive the Space channel thru buffer amplifier Z8 and Q3 and Q4 drive the Mark channel thru buffer amplifier Z9.

BUFFER AMPLIFIERS

The buffer amplifiers (Z8 and Z9) are set for a gain of ten and drive the channel filters.

VFO INJECTION OSCILLATORS AND INVERTERS

Both VFO Oscillators are identical and consist of an operational amplifier and an inverter for full wave output to the mixer stages. A 5K Ω pot (R145 Mark and R147 Space) is mounted on the PC board directly behind its respective front panel potentiometer for calibration of the front panel VFO controls. The frequency of the oscillators is always 750 Hz. higher than the RTTY tone frequencies.

CHANNEL FILTERS

The Mark and Space channel filters are identical and consist of three section, six pole, active IC filters utilizing precision capacitors and resistors. The center frequency of these filters is 750 Hz. with a 3 DB bandwidth of 85 Hz. The filter design is linear phase (Bessel Function) with constant group delay. This prevents pulse distortion in the filters during periods of frequency dispersive multipath distortion.

CRT CROSS DISPLAY

The output of the channel filters is fed directly to the input amplifiers of the 2 inch CRT cross display with no additional filtering. The CRT accurately displays the signals present in the channel filters.

BUFFER AMPLIFIERS

The output of the channel filters is also routed to the Output Buffer Amplifiers (Z13 and Z21), which drive the Precision Detectors thru the front panel Normal/Reverse switch. Operating with a gain of 1.3, the buffer amplifiers also drive the LED drivers Z35 and Z48, which in turn drive the Mark and Space LEDs on the front panel.

LED DRIVERS

The drive signal on the front panel LEDs is AC and no consideration need be given to polarity if the LEDs should require replacement.

PRECISION DETECTORS

The Precision Detectors consist of two op-amps (Z14/Z15 Mark and Z22/Z23 Space), which provide full-wave envelope detection of the Mark and Space signals. The op-amps maintain the diodes in conduction and no thresholding or cut-off occurs on weak signals.

The only exception to the rule of "identicalness" occurs in these Precision Detectors. The Mark and Space signals are detected such that the outputs have opposite polarities, which permits cancellation of noise and overlapping signals at the Multipath Combiner.

The outputs of the Precision Detectors are fed to the Low Pass Filters and are also available at the rear panel Diversity connectors. This method of diversity combining within the terminal unit does away with the need for an external combiner when two TUs are used in Dual Diversity and almost always assures that the best signal in either TU is in control during Dual Diversity operation.

LOW PASS FILTERS

The Low Pass Filters are identical, linear phase, active (four RC sections) filters which have been carefully tailored to provide optimum bandwidth for 45 to 75 baud operation. Unlike other filters, this filter is very tame in the presence of impulse noise and will not ring, but rather "flywheels" thru impulse noise and other signal distortions, such as fast fades and phase cancellations.

MULTIPATH COMBINER

The Multipath Combiner circuit is driven by the Mark and Space low pass filters, consisting of Z26, Z27 and Z29, and provides three distinct functions:

- 1) Passes the Mark and Space signals on to the AC Assessors as received from the Low Pass Filters in the presence of time and frequency dispersive multipath distortion without combining the Mark and Space channels.
- 2) Provides noise cancellation and combined Mark/Space information to the AC Assessors under normal (no distortion) conditions.

It is the combination of these two functions that accomplishes automatic operation of the MULTIPATH CORRECTORTM circuit.

- 3) Drives a DC coupled common mode amplifier (Z38) that in turn provides peripheral functions outside of the main data string, such as Autostart, Automatic Mark-Hold, Anti-Space, Anti-CW and Anti-Mark/Fade.

Since the outputs of the LPFs are of opposite polarities (as determined by the opposite output, polarities of the Precision Detectors), simultaneous information coming from the LPFs is essentially cancelled or highly attenuated, but normal Mark and Space signals (sequential in nature) are passed thru without attenuation.

In operation, the output of the Mark and Space low pass filters are combined at Pin 6 of Z26, TP3.

Simultaneously, the separate outputs of the Low Pass Filters are also maintained uncombined with Mark information going to Pin 2 of Z27 and Space information going to Pin 2 of Z29.

Since Z26 is operating with a gain of 2.2, its output from Pin 6, as presented to Pin 2 of either Z27 or Z29, is dominant.

Under conditions of multipath distortion, when the Mark and Space pulses are smeared or stretched in time or frequency, their overlapping portions are cancelled or highly attenuated by Z26 and do not show up at the output, but the original Mark and Space pulses are still passed directly to Z27 and Z29 thru their respective input resistors R67 and R79.

Thus it can be demonstrated that with normal signals, Z27 and Z29 are being driven mainly by signals from Pin 6 of Z26, and that signal combining has taken place and noise cancellation has been achieved thru amplitude summing of the opposite signal polarities at Pin 3 of Z26.

This is the function that permits copy of RTTY signals buried in the noise, because most of the noise is being cancelled, and only the wanted signal is passing thru Z26 unattenuated.

It can also be shown that if the Mark and Space pulses are stretched, the overlapping portions of these signals are also highly attenuated, and now the buffers Z27 and Z29, which are receiving information directly from the LPFs via R76 and R79, still have their information intact, uncombined and ready for processing by the AC Assessors, Slicers and the MULTIPATH CORRECTORTM circuit.

The output of the combining amplifier Z26 (TP3) supplies combined Mark and Space information to the DC coupled common mode amplifier (Z38) for the peripheral functions mentioned earlier.

An offset voltage may be set into this stage (Z26) via the Combiner Offset (R22) control mounted on the PC board, which permits setting the Mark mode of Autostart for Fast or Slow response, and which also sets the noise immunity level for the Mark autostart and automatic Mark-Hold circuits.

AC ASSESSORS

The outputs of the buffers drive a pair of identical AC coupled Assessor circuits which are similar to automatic threshold correctors (ATC) circuits. The advantage of the Assessor over the ATC is that the Assessor is AC coupled and a continuous tone in either channel will not cause large amounts of bias distortion. In this manner, the MPC-1000C will continue to copy in a single channel mode automatically when an interfering tone is present in the other channel.

The time constant of the Assessor circuit is set nominally at 200 milliseconds and is a good compromise between the slow flat-fade and the fast selective-fade rates that accompany HF propagation.

SLICERS

The output of each assessor circuit drives an IC operational amplifier configured as a Slicer with a small amount of fixed hysteresis. The outputs of the Slicers are DC coupled directly to the MULTIPATH CORRECTORTM circuit and are available at TP4 and TP5.

MULTIPATH CORRECTOR CIRCUIT

The MULTIPATH CORRECTORTM (MPC) consists of four identical CMOS (Z31, Z32, Z33 and Z34) DIP packages and functions as a regenerator that runs at the baud rate of the incoming signal. Since it is capable of responding to baud rates as high as 50,000 baud, no changes or adjustments are required in the terminal unit when signal speeds vary.

In addition to determining the correct position for the Mark/Space transitions in the presence of pulse stretching (overlapping), it also maintains the teleprinter in synch by latching the stop pulse, thus preventing a "legitimate" hit from generating a string of unnecessary hits.

The output memory of the MPC drives a third op-amp Slicer Z36 (TP6), which in turn, drives the output keyer circuits.

OUTPUT KEYERS

The keyer driver Q6 is emitter-coupled thru a total impedance of $2K\Omega$ to the base of the high level loop keyer, Q7. This impedance consists of two $1K\Omega$ resistors R199A and R199B outputted to E points 68 and 70, which are wired to the rear panel REGEN connectors J12 and J13. A jumper inside the terminal unit, across J12 and J13, completes the signal path between Q6 and Q7.

Removing this jumper permits an external receiver-type regeneration peripheral to be connected between the keyer driver and the high level loop keyer stages. The $1K\Omega$ resistors (R199A and R199B) provide impedance buffering to the outside world and prevent accidental damage to Q6 and Q7.

INTERNAL LOOP SUPPLY

The 120 VDC internal loop supply may be strapped on the main PC board for either 20 Mil or 40-60 mil neutral operation. These strap locations are just to the left of the two power resistors R168A and R168B.

Unless specified at time of order, Dovetron MPC-1000C are factory-adjusted for 60 mil operation.

For 60 mil operation, jumpers are installed at locations A and B, and R170, which is a voltage setting shunt across the front panel LOOP LED, is 33 ohms.

When the rear panel loop pot R169 is adjusted for 40 mil operation, it may be necessary to change R170 to 68 ohms to maintain a higher brilliance of the LOOP LED.

For 20 mil operation, a single jumper is installed in location C (jumpers in A and B are removed) and R170 is 100 ohms.

If the PKC-100 Polar Keyer option has been installed, the internal loop supply is used to provide the proper positive and negative polar voltages and the required polar currents.

Consult Dovetron Assembly Print 75152 and the PKC-100 Instruction insert at rear of manual.

FSK VOLTAGE LEVEL OUTPUTS

Two FSK voltage level outputs are available simultaneously: EIA RS-232C and MIL STD 188C.

EIA RS-232C is generated by Z45, which is driven by the low side of the high level loop supply: Mark: -12 volts, Space +12 volts. Output impedance: 1K Ω .

MIL STD 188C is generated by Z46, which is driven by the EIA FSK circuit. Mark: +6 volts, Space: -6 volts. Output impedance: 1K Ω .

By characteristic, these outputs are inverted in respect to each other, providing the operator with either polarity for Mark and Space, as required by his installation.

AFSK TONE KEYS

An Exar XR2206C (Z43) function generator provides phase-continuous, sine-wave AFSK Mark and Space tone signals suitable for driving the audio input stage of SSB, FM, PM and AM transmitters. This tone keyer is keyed by the output of the EIA FSK circuit, which is connected thru a jumper installed between AFSK INPUT (J7) and EIA FSK (J6).

This jumper may be removed, permitting the AFSK tone keyer to be keyed by a peripheral device via the AFSK INPUT connector on the rear panel. The EIA FSK output may be used to key the peripheral.

The Mark and Space tones of the tone keyer are independently adjustable over the range of 1200 Hz. and 3100 Hz. PC board pots provide a coarse adjustment, and the rear panel lock-pots provide a vernier adjustment.

The output level at the rear panel AFSK OUTPUT connector (J10) is 60 millivolts (peak to peak) and the output impedance is nominally 470 ohms resistive.

The output level and the output impedance may be modified by changing the value of the voltage divider R148/R149, or adding R204 at the output connector.

CW IDENTIFICATION

Provisions have been made for Narrow or Full CW ID on AFSK. The narrow CW ID is approximately 100 Hz with jumper A-B. When the jumper (B-A-C) connected to E56 is arranged B-C, Full-Shift CW ID is provided. This arrangement also provides keying of the EIA and MIL FSK stages.

Narrow shift CW ID keying of the EIA FSK stage is available by connecting J9 to E59 in place of the factory-installed connection to E56. No provision has been made for narrow-shift CW ID keying on the MIL STD 188C FSK line, but moving the high end of R160 from E62 to E61 will accomplish this.

LOW VOLTAGE POWER SUPPLIES

The +15 and -15 volt power supplies are regulated with independent voltage regulators that have internal over-current and over-temperature protection circuits built-in (Q8 and Q9). In the event of a short circuit on either supply line, the affected regulator will shut down without damage and will stay down until the over-load condition is cleared.

These regulators are mounted on the bottom side of the printed circuit board and are adequately heat-sinked with their mounting hardware. Both regulators are diode-protected against latch-up at turn-on.

POWER MAINS

The MPC-1000C may be powered from either 110 or 220 VAC, 40 to 400 Hz., single-phase power mains. The proper power is engraved on the rear panel directly below the power cord connector.

To convert from one line voltage level to the other, remove the top and bottom covers, and locate the jumpers installed next to the power transformer. One jumper is required for 220 VAC operation and two jumpers are required for 110 VAC operation.

The power available at the PRINTER connector for the motor of the companion teleprinter is always the same as the primary power being supplied to the TU.

The third wire ground in the power cord should always be tied to a good system or earth ground for maximum performance.

FUSES

The primary power is fused with a single Slo-Blow fuse:

110 Volts:	0.5 amps
220 Volts:	0.25 amps

The loop supply is fused with a 0.1 amp fast blow fuse. Although the loop supply is limited to 70 Ma by design, the fuse will protect the internal loop supply from overload should an external loop supply be plugged into the circuit.

The high voltage winding for the CRT's power supply is fused with a clip-in 1/32 amp slo-blow fuse (F3) located underneath the power transformer on the bottom side of the PC board.

DOT DEFLECTION CIRCUIT

The diode bridge (CR44) and Q12 form the dot deflection circuit. In the absence of a signal or noise, the center dot will be deflected to the bottom of the CRT's screen and defocused by the longer focal distance, preventing a burn spot in the center of the screen. The time constant of the dot deflection circuit is such that it will permit the dot to follow slow flat fades of weak RTTY signals and is indicative of signal path conditions.

A 7.5 volt zener (400 milliwatt diode (not normally installed) at CR53 will provide a faster than normal dot deflection upon loss of signal. The zener is used to prevent C65 from charging to full value, thus decreasing the time required for this cap to discharge to zero.

To fix the dot in the center of the screen at all times, remove Q12 from its socket and insert a jumper wire between the Collector and Emitter holes in the socket. Caution: The Collector circuit has +350 volts on it when operating.

CRT CROSS DISPLAY CIRCUITS

The 2 inch CRT Cross Display is driven by the final stage of the channel filters and displays a true picture of what information is contained in the filters. The Mark and Space channel amplifiers (Q10 and Q11) are DC coupled from the outputs of Z12 and Z20.

The gain of each amplifier is controlled by a PC board pot (Mark R180 and Space R173). Other variable controls located on the PC board are: Focus, Intensity, Astigmatism, Horizontal Centering and Vertical Centering. Caution: These controls have +350 volts on them.

A front panel photocell automatically adjusts the intensity of the CRT as the ambient light level at the operating location changes. This photocell is in series with a 62K Ω resistor (R222) and both are electrically shunted across the Intensity control on the PC board.

The response of this circuit to ambient light levels can be adjusted by changing the value of R222 or adjusting R195. Caution: This circuit operates at -140 VDC.

THRESHOLD CONTROL

The front panel THRESHOLD control sets the hysteresis level on the common mode amplifier (Z38) and the pulse width discriminator (Z39). These control the threshold level of the automatic Mark-Hold circuit and the FSK autostart circuit. A 12 o'clock setting is considered normal. The automatic Mark-Hold feature is defeated by rotating the THRESHOLD control to full counter clockwise (CCW).

The main purpose of the Threshold control is to force the TU to run "open" on noise when copying very weak signals. The Signal Loss LED is a convenient indicator of the proper threshold setting.

AUTOMATIC MARK HOLD THRESHOLD

The Auto-Mark/Hold function may be inhibited by turning the front panel THRESHOLD control fully CCW. This will force the terminal unit to run "open" on noise and is often desirable when copying very weak signals at the threshold of noise.

This mode of operation is often used on machine speed commercial circuits where the Mark-Hold function in the terminal unit is provided entirely by the Marking carrier.

COMMON MODE AMPLIFIER

The Common Mode Amplifier (Z38) has both of its input ports tied to the output of the Multipath Combiner Amplifier and is very tame in the presence of input noise. When the output of the Multipath Combiner Amplifier goes high on a Marking signal, the Common Mode Amplifier changes state and drives a pulse width discriminator. The threshold level of the Common Mode Amplifier is set by the front panel THRESHOLD control, which injects a small amount of hysteresis.

PULSE WIDTH DISCRIMINATOR

The time constant of the Pulse Width Discriminator, which is used for Auto-Mark/Hold, Anti-Mark/Fade, Anti-Space, Anti-CW and FSK Autostart, is set by the values of C47 and R119.

The factory installed value of R119 is 180K Ω (5%), and provides a time constant of approximately 200 to 220 milliseconds.

With this timing, very fast response to unwanted signals is provided in the Anti-CW and Anti-Space functions. If the timing is too fast, the Automatic Mark/Hold circuit might have a

tendency to put the terminal unit into Mark-Hold during the last character bit (the 5th bit) of the character BLANK, which is comprised of six spacing bits; five character bits plus the Start (spacing) bit.

This anomaly of printing the character O instead of BLANK will only occur at 45.45 Baud (60 WPM), and if it occurs, and is objectionable, R119 should be increased in value to 240K Ω , 5%.

SIGNAL LOSS INDICATOR

The Signal Loss circuit and amplifier (Z37) receive "state" information from Z36, which is the slicer on the output of the MULTIPATH CORRECTORTM, from Z39, which is the output of the pulse width discriminator, and from Z26, the Multipath Combiner amplifier.

When Z37 senses a Mark-Hold condition with no marking carrier in the Mark channel, it signals that an RTTY signal is no longer present and indicates "signal loss" by turning on a front panel LED indicator. This information is also buffered thru a 1K Ω resistor to the rear panel for system alarm and control purposes.

Placing the Standby Switch to the Standby position also forces the Signal Loss LED indicator on.

In those units with a bipolar Green/Red LED, Green indicates a signal is present, and Red indicates a signal loss condition.

MODE SWITCH

The Mode Switch has five positions:

- 1) DIV OFF: Diversity Off.
- 2) MO: Mark Only.
- 3) MS: Mark-Space (Normal).
- 4) SO: Space Only.
- 5) MS-REV: Mark-Space Reversals.

The DIV OFF position is the same as MS, which is normal Mark and Space operation, but if two MPC-1000Cs are connected together for Dual Diversity operation, the DIV-OFF position disconnects their interconnecting circuits and permits both TUs to be used independently.

MO and SO permit either Mark-only or Space-only operation by shutting down the local injection oscillator in the opposite channel.

MS is the normal operation mode and permits full automatic In-Band Diversity operation of the TU. If one channel should fade into the noise, the TU automatically derives all of its data from the other channel by use of the Assessor circuit in the working channel and from a psuedo channel that is automatically generated in the Multipath Combiner circuit.

The MS-REV position activates a square generator that drives the AFSK tone keyer, and routes the tones from the tone generator into the front end of the TU. When the square wave generator is set to one half of the baud rate of the companion teleprinter, the teleprinter will print a continuous string of RYs. Example: 45.45 baud = 22.8 Hz.

The RY (MS-REV) generator is adjusted by R163.

The frequency of the RY generator may be read by a frequency counter at the EIA or MIL FSK output connectors on the rear panel.

If the RY Generator is running slightly fast or slow, the teleprinter will have a tendency to print a string of Ys. If an external UAR/T type regenerator is being used, the teleprinter will print only Ys because the regeneration technique of the UAR/T will not permit "loading" a string of Mark-Space Reversals in any sequence other than Ys.

AUTOSTART

In the FSK Autostart mode, the autostart timing circuits are driven by the previously described common mode amplifier and the pulse width discriminator circuit. Both the LEVEL control and the THRESHOLD control have some influence on the turn-on time and time-out characteristics of the FSK auto-start.

This mode of operation is intended to monitor and shut off the teleprinter's motor during the long marking periods common to commercial press and weather station.

Turn-on is accomplished in a few characters and time-out is approximately 20 seconds.

In the MARK Auotstart mode, the autostart timing circuits are driven by the output of the Multipath Combiner amplifier. Although the LEVEL control has a little bit of influence, the THRESHOLD control has no influence over turn-on or time-out.

This mode of operation is less susceptible to false turn-ons by noise pulses and times-out in approximately seven seconds.

The time-out period of both modes is a function of C51 and R131 and may be changed to suit the operator's preference.

The Mark mode of Autostart is also affected by the offset voltage at Z26 as created by the Combiner Offset control R221. The greater the offset, the more immunity to noise pulses, but the turn-on time to a Marking carrier will be slower.

The Mark mode is also immune to a CW signal, keyed or continuous, in the Space channel.

AUTOSTART RELAY CIRCUIT

The relay driver Q5 is driven by Z42, when the front panel MOTOR Control switch is in the AUTOSTART position. In the MOTOR OFF position, the relay cannot be actuated. In the MOTOR ON position, the relay solenoid is grounded thru the MOTOR control switch.

SECTION VII

BLOCK DIAGRAMS

THE FOLLOWING BLOCK DIAGRAMS ARE NOT COMPLETE. THEY ARE MEANT FOR REFERENCE USE ONLY.

- PAGE 24: Input Amplifier, Inverter, Full-Wave Mixers, VFO Oscillators, Buffer Amplifiers and Channel Filters.
- PAGE 25: CRT Cross Display, Amplifiers, Dot Deflection Circuit, Normal/Reverse Switch, LED Drivers, Precision Detectors and Low Pass Filters.
- PAGE 26: Multipath Combiner Circuit, Assessors, Slicers, MULTIPATH CORRECTORTM, Slicer and Voltage Regulators.
- PAGE 27: Driver, REGEN IN/OUT Circuit, High Level Loop Keyer, Internal Loop Supply, EIA RS-232C and MIL STD 188C FSK Outputs, LOOP LED circuit, RY GENERATOR AND AFSK Tone Keyer.
- PAGE 28: Common Mode Amplifier, Pulse Width Discriminator, FSK Autostart, MARK Autostart, Autostart Trigger-Driver-Relay Circuit, Signal Loss Amplifier and Automatic Threshold Level Control circuit.

Circuits not included in these diagrams are:

Remote Control, CRT Power Supplies, MO and SO switching, Automatic CRT Intensity Control, Automatic Threshold Level Control in MO/SO modes and Keyboard Actuated Autostart.

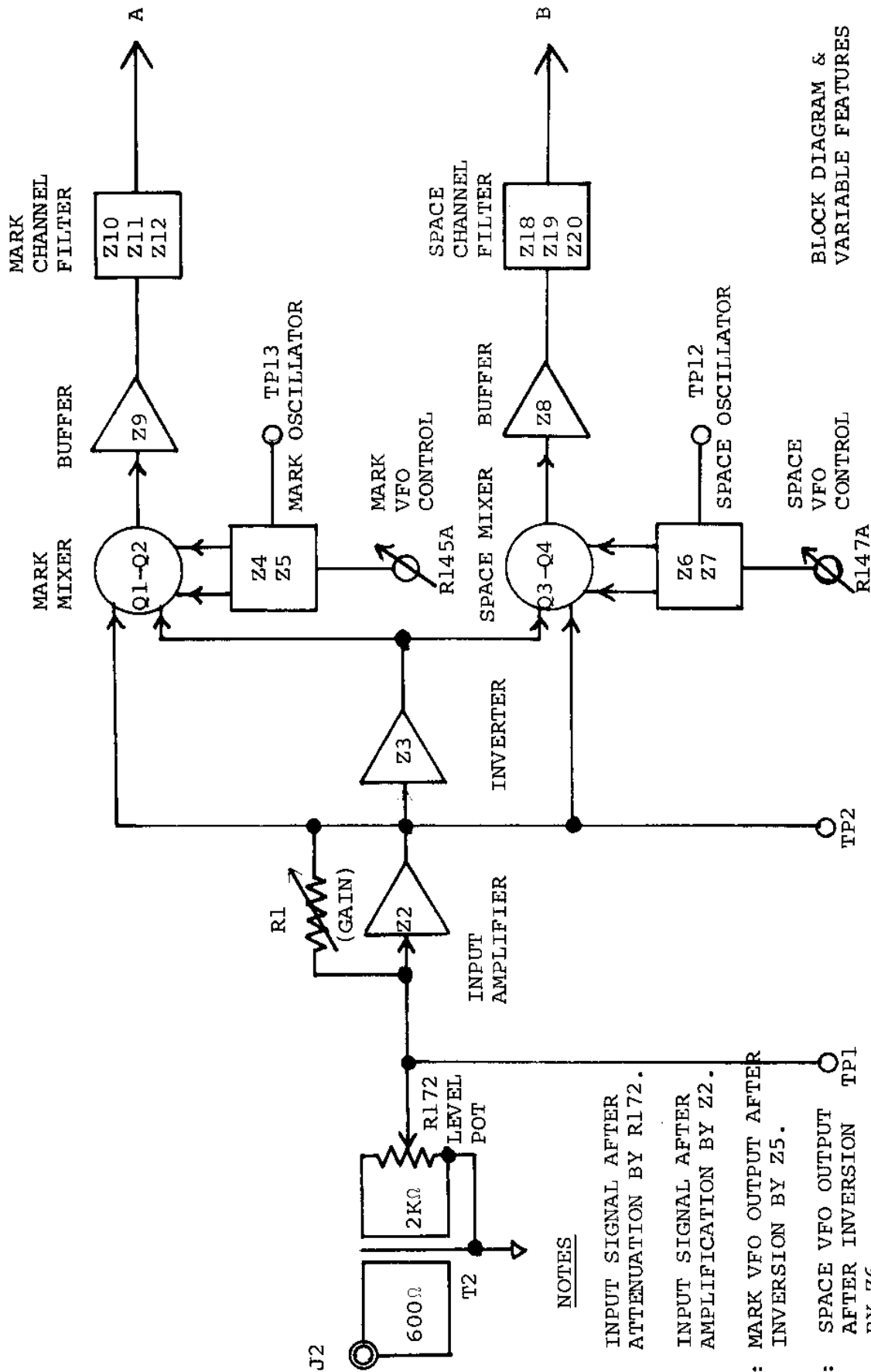

BLOCK DIAGRAM & VARIABLE FEATURES

NOTES

- TP1: INPUT SIGNAL AFTER ATTENUATION BY R172.
- TP2: INPUT SIGNAL AFTER AMPLIFICATION BY Z2.
- TP12: MARK VFO OUTPUT AFTER INVERSION BY Z5.
- TP13: SPACE VFO OUTPUT AFTER INVERSION BY Z6.

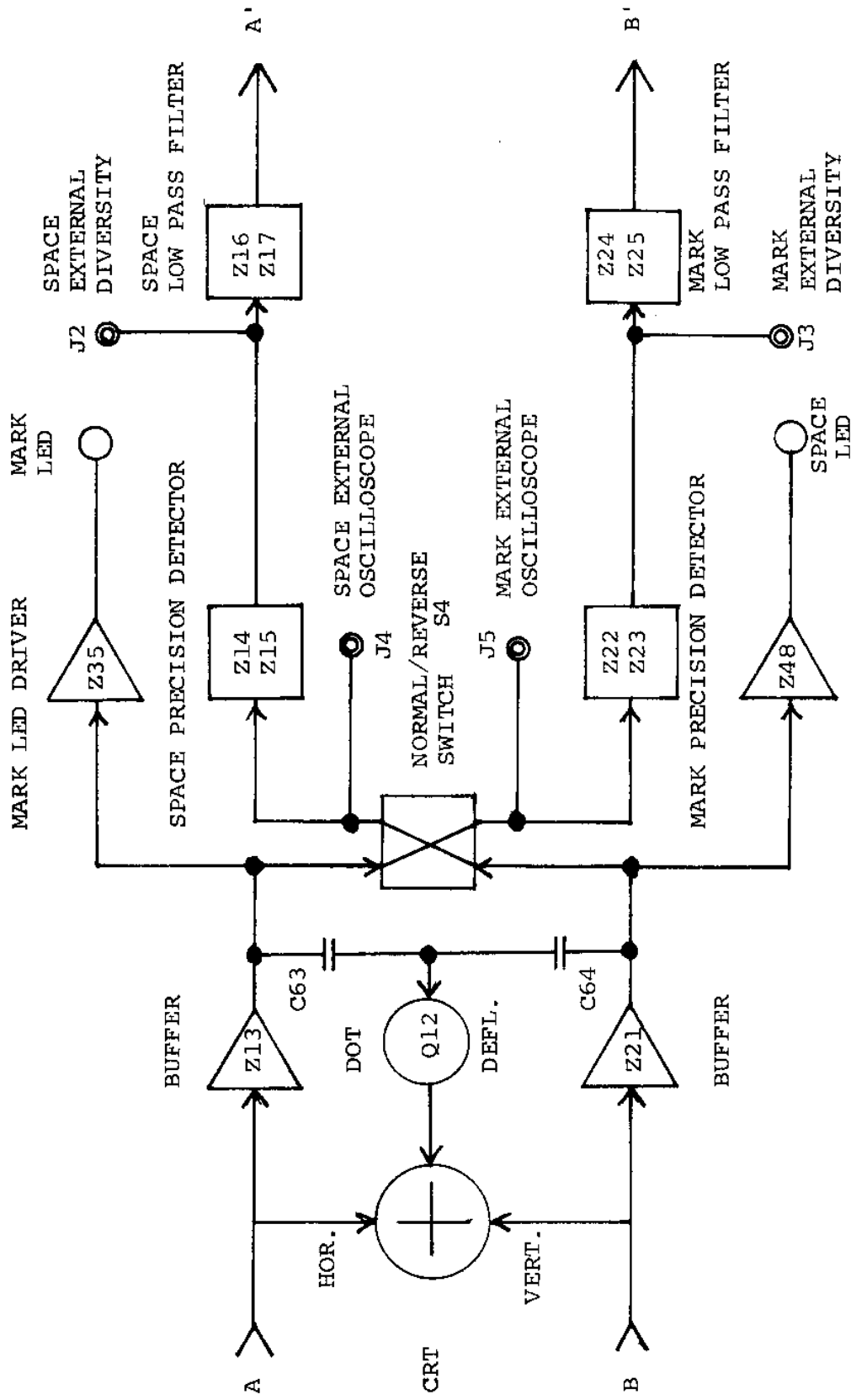

BLOCK DIAGRAM &
VARIABLE FEATURES

THE EXTERNAL SCOPE AND EXTERNAL DIVERSITY CONNECTORS AT THE REAR PANEL MAY BE USED FOR CONVENIENT TEST POINTS FOR TROUBLE SHOOTING OF THE VARIOUS STAGES.

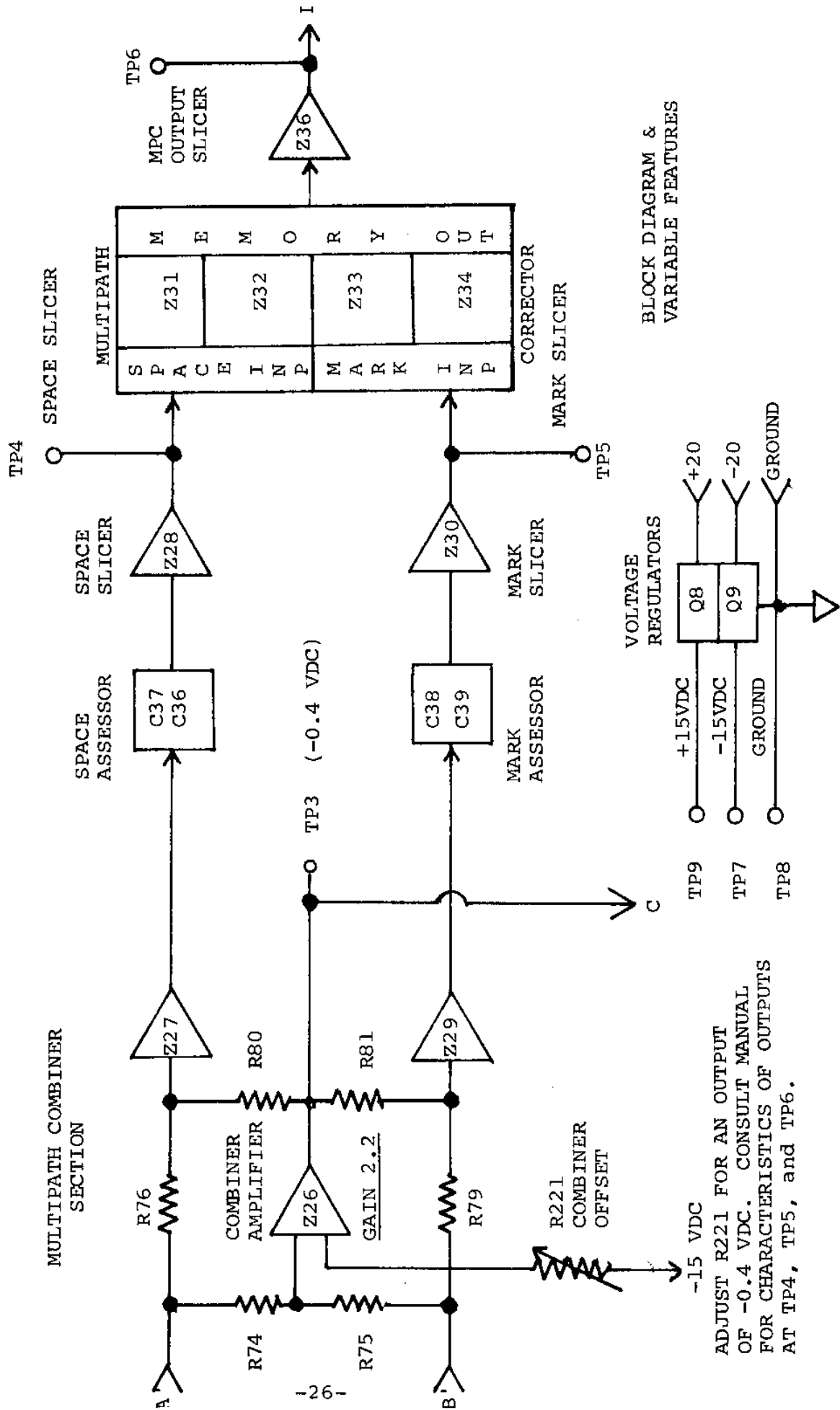

BLOCK DIAGRAM & VARIABLE FEATURES

ADJUST R221 FOR AN OUTPUT OF -0.4 VDC. CONSULT MANUAL FOR CHARACTERISTICS OF OUTPUTS AT TP4, TP5, and TP6.

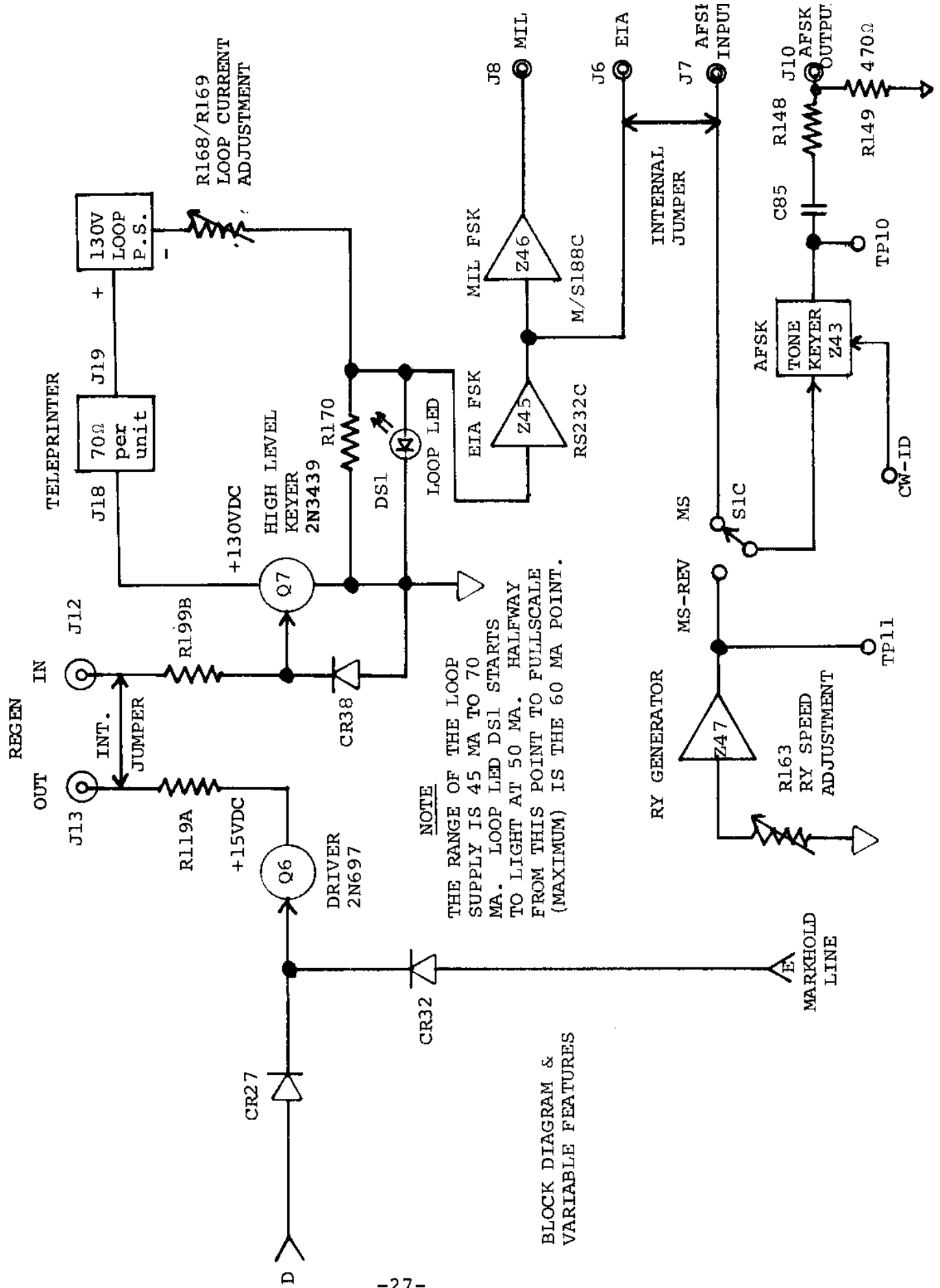

NOTE
 THE RANGE OF THE LOOP SUPPLY IS 45 MA TO 70 MA. LOOP LED DS1 STARTS TO LIGHT AT 50 MA. HALFWAY FROM THIS POINT TO FULLSCALE (MAXIMUM) IS THE 60 MA POINT.

BLOCK DIAGRAM & VARIABLE FEATURES

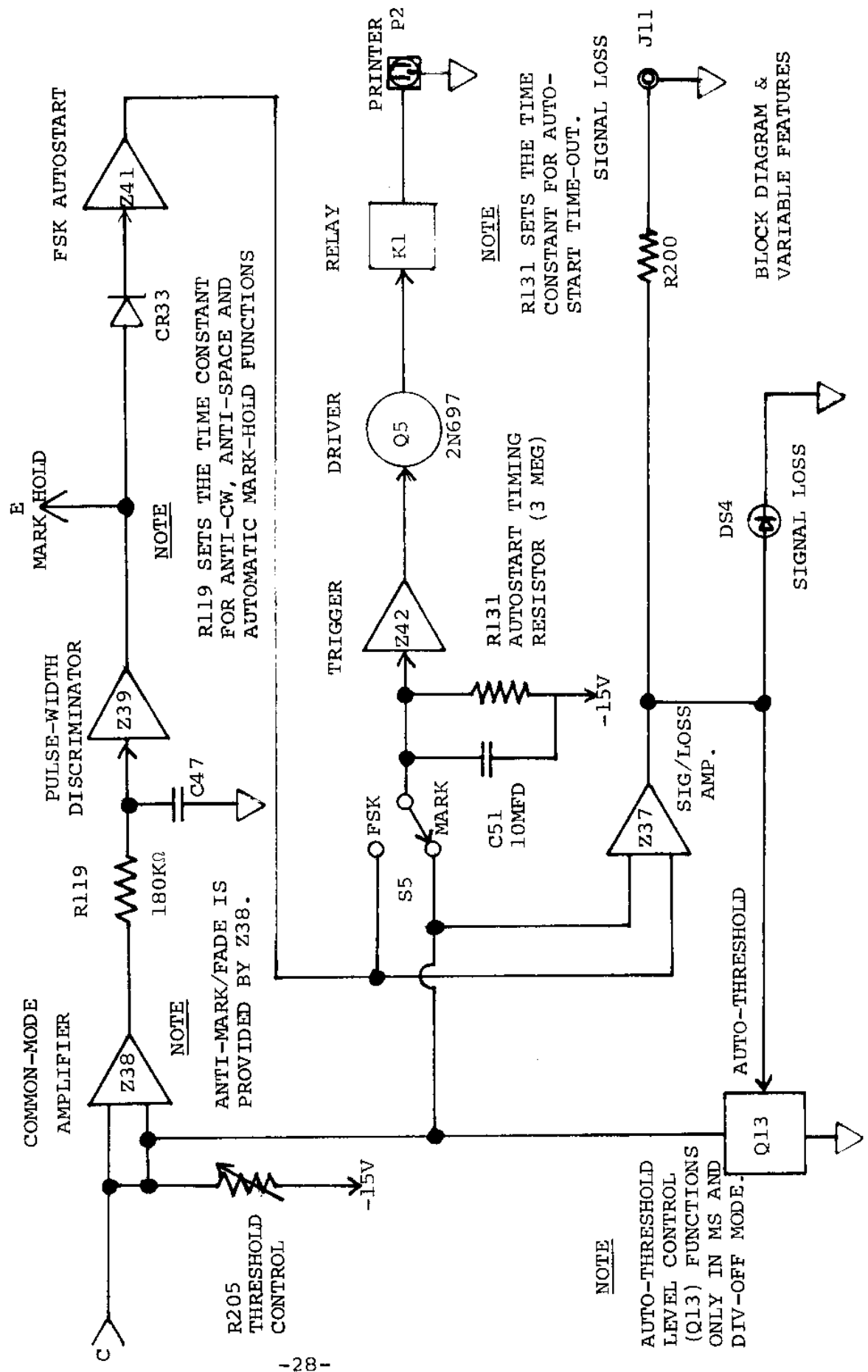

SECTION VIII

REGENERATION INTERFACE

The MPC-1000C terminal unit has been designed to afford a fast and simple interface to signal regenerators, speed converters, code scramblers and other digital devices, similar to the Dovetron TSR-500 internal or TSR-1000 external Regenerator/Speed Converters.

To prepare the TU for interfacing, remove the top:

- 1) Locate and remove (or cut) the jumper between J12 (REGEN IN) and J13 (REGEN OUT). This completes the Receive-only modification.
- 2) Locate and remove (or cut) the jumper between J6 (EIA FSK) and J7 (AFSK INPUT). This second modification adds the transmit function if the regenerator has a bilateral (Xmit/Rec) mode.

The input section of the receiving regenerator will be driven by J13. The output of the Regenerator will drive the high level loop keyer via J12.

In the transmit mode, the regenerator will be driven by J6 (EIA FSK) and in turn, will drive the AFSK tone keyer in the TU via J7 (AFSK INPUT).

All four ports are impedance buffered and have the following signal characteristics and requirements:

J13-REGEN OUT: +13 volts Mark, zero volts Space. 1K Ω resistive.

J12-REGEN IN: +5/+15 volts Mark, zero or less volts Space. 1K Ω resistive.

J6-EIA FSK: -15 volts Mark, +15 volts Space. 1K Ω resistive.

J7-AFSK INPUT: Less than +0.5 volts Mark, more than +2.5 volts Space. 20K Ω resistive.

The MIL STD 188C FSK signal at J8 may be used in lieu of the EIA FSK (J7) if the opposite polarity is required as a transmit drive signal to the regenerator.

The AFSK INPUT of the tone keyer is buffered by 20K Ω (R152) and this value may be decreased if any difficulty is encountered in driving the tone keyer from the regenerator. The tone keyer switches from Mark to Space at approximately +2.5 volts.

To return the TU to normal operation, replace the jumpers or install a shielded patch cable between J12 and J13 and another shielded patch cable between J6 and J7.

Any regenerator used with the MPC-1000C should share a common signal and power ground.

SECTION IX

CALIBRATION PROCEDURES

VFO CALIBRATION

If a frequency counter is available, it may be connected directly to the wiper of the Mark or Space front-panel VFO pot, or to TP12 or TP13. Set the front panel pot to 2125 Hz. Adjust the PC board pot directly behind the pot being calibrated to a frequency 750 Hz higher than the frequency indicated by the VFO calibration markings: 2750 Hz.

If a frequency counter is not available, the PC board pots (with power removed) may be adjusted with an ohmmeter to 2000 ohms. Final calibration is then done against a known frequency source, using the CRT cross display as an indicator.

Do not attempt to calibrate the VFOs with a frequency source without first setting the PC pots to approximately 2000 ohms, as it is possible to set the oscillators on the wrong side of the channel filters.

The stability of the local oscillators is better than 400 PPM/°C, Typically 200 PPM/°C.

AFSK TONE KEYSER ADJUSTMENT

If the front panel VFO controls have been calibrated, the rear panel Mark and Space tone pots may be adjusted against the front panel VFO calibrations, using the CRT as a tuning indicator, and the RY generator (MS-REV) to switch from Mark to Space and back again. The range of the AFSK tone generator is 1200 to 3100 Hz, and coarse adjustment is provided by the two PC board pots at R208 and R210.

A frequency counter may be connected to the AFSK output connector for a more precise calibration of the Mark and Space tones.

To accomplish this, turn the LEVEL control all the way CCW and put the mode switch in MS, guaranteeing that the TU is now in Mark-Hold and generating a Mark tone.

Adjust the rear panel Mark tone pot to the desired frequency.

Open the loop circuit, forcing the tone keyer to the Space condition, and adjust the Space tone pot to the desired space tone frequency.

The loop may be opened by holding down the teleprinter's Break button, inserting an open phone plug into one of the high level loop jacks, or by removing the 0.1 amp fuse at F2.

Verify that the loop is in the Space condition (loop LED extinguished) before adjusting the Space tone pot on the rear panel.

INPUT GAIN CONTROL

The voltage gain of the input amplifier Z2 is controlled by the amount of feedback as set by R1. This pot is factory set at half-scale (250K Ω) and provides a gain of 25. It may be operator adjusted after the audio level of the companion receiver has been adjusted. The front panel LEVEL pot R172 functions as an attenuator between the receiver and the terminal unit.

COMBINER OFFSET CONTROL

The offset of Z26 is controlled by injecting a small amount of negative voltage into Pin 3 of Z26 via R221. With the LEVEL control turned full CCW, set R221 so that the offset voltage at TP3 is -0.4 volts. The offset voltage should be checked whenever an op-amp is changed in the low pass filters.

A slower response to a marking carrier when in MARK autostart and a higher immunity to false starts from impulse noise may be had by setting this offset as low as -0.6 volts.

Fast autostart on weak RTTY signals may be accomplished by setting the offset to -0.2 volts, but the MARK autostart circuit will be more susceptible to false starts from noise impulses.

SCOPE GAIN

A convenient method of setting the gain of the Mark and Space CRT gain pots is to select the MS-REV mode, turn the LEVEL pot all the way CW, adjust the front panel VFO pots to the frequency of the AFSK tone keyer, peaking them for maximum deflection in the horizontal and vertical axes, and then:

Adjust the gain pots (R173 and R180) for line lengths of 1.5 inches.

Caution: If the gain is down in one channel, due to a component failure in the front end, the CRT scope will display the loss of signal power. Before readjusting the scope gain pots, check the balance between the two channels at the External Scope connectors on the rear panel, which is the output of the buffer amplifiers immediately following the channel filters.

RY GENERATOR

When the mode switch is in the MS-REV position the AFSK tone keyer is connected to the input of the TU and the audio line from the external receiver is disconnected. The AFSK tone keyer is driven by the square wave generator, Z47.

The frequency of the square wave generator is set by PC board pot R163.

When adjusted for RY generation at one speed, RYs will not be printed at any other speed.

Select the most common speed that you intend to operate the teleprinter at and adjust R163 until the teleprinter prints a continuous string of RYs.

These Mark and Space reversals are balanced 50/50 and make an excellent signal source for checking the various stages of the terminal unit, for machine maintenance, and for occupying a radio channel.

When used with a UAR/T type regenerator, only Ys will be printed. This is also true of some types of video displays and solid state teleprinters, because their center-sampling techniques do not permit decoding an "R" from a string of continuous mark-space reversals.

LOOP CURRENT ADJUST

The internal high voltage loop supply may be adjusted from 30 Ma. to 70 Ma. by the rear panel pot R169.

With a normal teleprinter load of approximately 70Ω , the 60 Ma. setting is very close to mid-scale.

To set the loop current to 60 Ma. without the use of an external milliammeter, adjust the loop pot to MIN. The front panel LOOP LED should be extinguished. Turn the pot up (CW) slowly. The LED begins to indicate at 50 Ma. Since full-scale is 70 Ma., setting the pot halfway between the point where the LED begins to indicate (50 Ma.) and full-scale (70 Ma.) is 60 Ma.

SECTION X

VARIABLE FEATURES

In order to satisfy the largest possible number of requirements RTTY demodulation under varying circumstances, many variable features have been included in the MPC-1000C and are operator selectable.

CONTROLLED LIMITING

Although the MPC-1000C is a linear AM terminal unit, a form of controlled limiting takes place when the input amplifier and the various buffer amplifiers are driven into saturation.

A slight amount of limiting will not increase the error rate on good signals. For this reason, it is advisable to set the LEVEL control to a point where controlled limiting takes place on strong signals, and the moderate and weak signals are copied in a linear mode.

EXTERNAL SCOPE

External rear panel scope connectors are provided to permit dual trace analysis of the Mark and Space channel information simultaneously. This type of display provides instant recognition of signal and circuit characteristics, including multipath pulse stretching, selective fading, keying errors at the transmitting end, etc. The output impedance of the External Scope lines is 100K Ω .

EXTERNAL DIVERSITY

Two MPC-1000C Terminal Units may be interconnected for Diversity operation by jumpering the External Diversity connectors together, Mark to Mark, and Space to Space.

All diversity combining is accomplished within the two TUs and an external diversity combiner is not required.

Laboratory and field testing has shown that the stronger of the two signals in any one channel is the best choice and the combining circuits in the terminal units work in this manner.

The teleprinter may be plugged into either TU. The DIV-OFF position of the front panel mode switch is the same as the MS position, but the External Diversity lines are disconnected without having to disconnect the diversity cables at the rear panel.

REMOTE CONTROL (LOCK)

A LOCK connector is provided at the rear panel for remote control of the terminal unit.

When the front panel Standby switch is in the ON position, a +5 to +15 volt logic level at the LOCK terminal will force the TU into Mark-Hold thru diode CR50.

If CR54 is installed, the logic level at the LOCK connector will also prevent the FSK autostart circuits from timing out, i.e., the motor cannot shut off, and FSK time-out will commence only after the LOCK signal is removed.

If CR55 is installed, the logic level at the LOCK connector will also prevent the MARK autostart from timing out.

The installation of CR54 and CR55 is left to the discretion of the operator. Any signal diode similar to 1N914 is adequate.

KEYBOARD ACTUATED AUTOSTART

Diode CR34 is factory-installed. This circuit prevents the FSK Autostart from timing out as long as characters are being generated on the loop line from a keyboard, etc.

It also permits a Keyboard Actuated Autostart function. When the break button on the keyboard is momentarily depressed, the EIA FSK output switches from Mark to Space, actuates the FSK Autostart circuit for 20 seconds, and permits message retrieval from the teleprinter's typing unit.

This feature may also be added to the MARK Autostart mode by the installation of CR52, but the time-out of the Mark Autostart mode then is influenced to some extent by the setting of the front panel THRESHOLD control.

AUTOMATIC THRESHOLD CONTROL

A P-channel J-Fet (Q13) switch is actuated by an incoming RTTY signal and lowers the value of front panel THRESHOLD control by connecting R216 across R205. This circuit permits the TU to track signals taking deep fades into the noise without having to reduce the TU's THRESHOLD control.

If the signal is finally lost, the threshold level of the TU is reset to whatever level is manually set by the front panel THRESHOLD control. The time constant of this "reset" is a function of the time constant of C82 and the impedance of Q13. A faster reset is available to the operator by the addition of R214 and CR58.

A variation of this circuit consists on switch section S1F of the Mode switch and R219. When the TU is switched to MO or SO operation, the threshold level is lowered to compensate for the loss of signal power when in single channel operation.

This is meant as a convenience feature, preventing the operator from having to readjust the THRESHOLD control on weak signals if it is necessary to switch to single channel copy.

STANDBY SWITCH REMOTES

Three Remote connectors are provided on the rear panel: 1, 2 & 3.

Each remote is connected to one terminal on a SPDT section of the Standby switch. The wiper is on Remote 1 and is current protected with a 33 Ω resistor R148. Remote 2 is connected to the ON position and Remote 3 is connected to the Standby position. Consult the schematic for a full understanding of the function of this switch.

Simple transmitter-receiver remote control from the TU's standby switch can be accomplished in a variety of ways.

With a VOX actuated transmitter, the AFSK tone generator output can be routed thru this switch, using the VOX circuit to turn the transmitter on when the AFSK tone is switched into the audio input of the transmitter. See KWM-2/KWM-2A section on next page.

Another example is that Remote 1 can be grounded with a shorting plug and Remote 2 and 3 can then be used to ground various switching schemes.

These remote lines are printed circuit traces on the PC board and no attempt to carry 110 VAC/VDC should be made.

REACTANCE MODULATOR KEYS

In applications, where it is desirable to key a voltage controlled oscillator, reactance modulator, etc., locations Q14 and R217 have been provided. R217 should be 10K, 1/4 W.

As an example, the FSK-1 reactance modulator keyer line of the Central Electronics 100V/200V exciters may be keyed from E87. In this particular application Q14 should be a high voltage PNP transistor such as the 2N3930. Low voltage transistors may be used for applications that do not require high voltages. The 2N3439 may be used for high voltage keying that requires a NPN transistor.

BAUD RATE CONSIDERATIONS

The bandwidth of the Terminal Unit has been designed for optimum performance over the range of 45 to 75 baud, i.e., 60 to 100 words per minute.

For higher baud rates, the bandwidth of the Low Pass Filters must be expanded by changing eight resistor locations:

R45, R46, R47, R48, R70, R71, R72 and R73.

These locations presently have 510K resistors installed.

For 110 Baud operation, change all 8 locations to 330K Ω , 5%.

For 150 Baud operation, change all 8 locations to 250K Ω , 5%.

At 150 Baud, the channel filters should also be opened up, although much of the distortion created by the "tight" filters will be corrected for in the MULTIPATH CORRECTORTM circuit.

If the terminal unit is to be used exclusively on 45.45 or 60 Baud circuits, a slight improvement in signal to noise ratio can be achieved by narrowing the bandwidth of the terminal unit by replacing the 8 510K Ω resistors with 8 750K Ω , 1/4W, 5%.

KWM-2/KWM-2A CONSIDERATIONS

Some transceivers (Collins KWM-2/A, etc.) do not make provisions for turning off their audio input circuits during receive. By maintaining these audio circuits live, Single Sideband VOX operation is available.

When using this type of transceiver for RTTY, the Mark and Space tones from the AFSK tone keyer in the Terminal Unit will be heard in the audio background during receiving periods.

Remotes 1, 2 and 3 may be used to interrupt the AFSK tones during receive, or may be used to short the AFSK tone output to ground during receive.

In either case, the AFSK tones will not be heard in the transceiver's audio output during receive, and the TU's Standby switch can still be used to switch to "transmit" via the VOX circuitry.

Although the bandwidth of the KWM-2A is very wide (2.1 KHz), it is a superb RTTY transceiver.

The center frequency of the channel filters in the E Series MPC-1000(C) Terminal Units have been moved to 750 Hz and provide excellent image rejection when used with the KWM-2A and with the 51S1 all-band receiver and its 2.4 KHz filters.

51S1 CONSIDERATIONS

The BFO crystal in the 51S1 is mounted on top of the chassis in a crystal socket and may be easily changed.

When used in RTTY service, if the 500 KHz BFO crystal is replaced with a 498.8 KHz unit, the standard tones of 2125, 2295 and 2550 may be copied thru the 800 Hz CW filter. The USB (2.4 KHz) filter permits the standard combination of 2125 MARK and 2975 SPACE to be used.

By copying Narrow and Medium shift signals thru the 800 Hz CW filter, there is less chance of the receiver's AGC being captured by strong adjacent-channel signals.

A 502.2 KHz crystal may also be used, and LSB used for the wide-shift (2125 and 2295) operation, but since the USB and CW filter positions are adjacent to each other on the Filter Switch of the 51S1, (and since the CW filter has a USB offset) the use of the 498.8 crystal is preferred.

SECTION XI

SERVICE INSTRUCTIONS

CAUTION: HIGH VOLTAGES ARE PRESENT IN THIS UNIT

Before removing the top and bottom covers, remove the AC power cord at the rear panel AC connector.

CAUTION: HIGH VOLTAGES ARE PRESENT IN THIS UNIT

The AC mains are exposed inside the unit at the rear of the AC input connector, on the rear of the front panel power switch, on the contacts of the autostart relay, on the fuse holder F1, and at the rear of the printer's motor connector.

The +350 and -175 volt lines for the CRT are exposed on both sides of the PC board.

The traces and wires running to the front panel photocell socket are at -140 volts.

The high level loop voltage (130 VDC) is exposed on the top of the power resistor R168 and at fuse holder F2.

If the high level loop line is open, the loop filter capacitor does not bleed to zero.

Although the electrolytic filters "bleed" to zero volts in a few seconds, the wise approach is one of complete mistrust.

TEST POINTS

TP1 is the signal line to the input amplifier Z2. This point will have audio signals on it, and the amplitude is controlled by the front panel LEVEL control.

TP2 is the output of the input amplifier Z2. When setting the gain of Z2 by adjustment of the feedback resistor R1, TP2 can be monitored for saturation (limiting).

TP3 is the output of the Multipath Combiner amplifier and permits the proper setting of the Combiner Offset control R221. R221 is factory set for an offset of -0.4 volts. This measurement is made with no signal input and the LEVEL control turned full CCW.

TP4 is the output of the Space slicer following the Space Assessor.

TP5 is the output of the Mark slicer following the Mark Assessor.

TP6 is the output of the third slicer, following the MULTIPATH CORRECTORTM circuitry.

A fast test of all the logic elements from the front end of the TU thru to the output of the final slicer is:

- 1) Switch the Mode switch to MS-REV and tune the TU to the Mark-Space tones being generated by the AFSK tone keyer.
- 2) Check TP1 and TP2 for signal input and output at Z2.
- 3) Check TP3 for a sine wave (same frequency as RY generator) with an offset of -0.4 volts.
- 4) Check TP4 and TP5 for square wave slicing (+15 volts). TP5 slices only with the front panel MULTIPATH CORRECTOR switch turned ON. If turned OFF, no slicing takes place (-15 volts).
- 5) If the MULTIPATH CORRECTORTM circuit is functioning properly, TP6 will slice symmetrically ± 15 volts.

TP7 is the output of the -15 volt regulator.

TP8 is power ground, chassis ground and signal ground.

TP9 is the output of the +15 volt regulator.

TP10 is the output of the AFSK tone keyer (pin 2 of Z43).

TP11 is the output of the RY Generator (pin 6 of Z47).

TP12 is the output of the inverter (Z7) following the Space channel oscillator (Z6).

TP13 is the output of the inverter (Z5) following the Mark channel oscillator (Z4).

TP12 and TP13 may be used to check the frequency of the Mark and Space local oscillators.

A quick check of the Test Points will usually indicate in which section of the TU that a servicing problem exists.

The most common failure is a shorted op-amp.

The best way to find a shorted op-amp is to run the TU for a few minutes and then feel the cases for one that appears to be running hotter than the rest.

If a bad op-amp shorts one of the power supplies, the low voltage regulator on that supply will shut-down without damage.

When the short is cleared, the regulator will cool off and come back up.

If the output of either regulator is above 20 volts as measured at TP7 or TP9, replace the regulator.

The MULTIPATH CORRECTOR™ may be quickly tested by turning it OFF. If the terminal unit continues to function, the MPC is probably functioning properly.

If it is determined that the MULTIPATH CORRECTOR™ is not functioning properly, check Pin 8 of Z31, Z32, Z33 and Z34 with an oscilloscope with a bandwidth of at least 15 MHz.

The output of Pin 8 should be at +15 volts and the high speed scope will show negative going pulses running thru the screen.

A DC or low frequency scope may be used by checking Pin 9 for a square wave, +15 volts to zero volts.

The CRT circuit is straightforward and may be checked as any other vacuum tube circuit. If the cross display fails completely, feel the rear portion of the shield assembly for filament heat. If cold, resolder Pins 1 and 11 on the tube socket with a high heat soldering iron. Sometimes the filament pins of CRTs develop a cold solder joint and the high impedance of such a solder joint shuts off the current in the filament circuit.

If the CRT display blooms, check F3 under the PC board. If F3 is blown, check for leaky filter capacitors (C66 or C67) and shorted power diodes (CR45 and CR46).

The scope input amplifiers (Q10 and Q11) can be checked for excessive heat, indicating a transistor failure or lock-up

due to low Beta.

CAUTION: The cases of Q10 and Q11 are collector circuits and operate at +350 volts.

The TEST PROCEDURE and TROUBLE SHOOTING GUIDE in Section XI should be followed in trouble shooting the MPC-1000(C).

SECTION XII

TEST PROCEDURE AND TROUBLE SHOOTING

The MPC-1000(C) is very easy to trouble shoot, using the built-in RY Generator, AFSK tone generator and the 2 inch cross display CRT as BITE (Built In Test Equipment).

A 15 MHz oscilloscope is preferred (for testing the high speed CMOS circuits) in the MULTIPATH CORRECTORTM circuit, but a slower speed oscilloscope may be used.

Set up the following test conditions:

Set LEVEL and THRESHOLD controls straight up (SUP). If these controls are changed during a particular test, return them to SUP before going to the next test.

Set the front panel Mode switch to MS-REV (RY Generator).

Set all front panel toggle switches UP.

Adjust the front panel Mark and Space VFOs for maximum deflection of the horizontal and vertical traces on the CRT cross display. The display should be a cross, not a circle or a square, which would indicate both channels are tuned to the same tone frequency. It makes no difference which tone is used for Mark, etc.

All IC op-amps will be measured at the output pin, which is pin 6, except where a test point (TP) has been provided for convenience, or where an op-amp's output can be measured at a rear panel connector.

An accidental shorting of Pin 6 to Pin 7 will destroy the op-amp. For this reason, the op-amps in the filter circuits and precision detectors have small printed circuit tabs protruding from under the IC's socket that are large enough to be contacted with a scope probe.

If the op-amp is shorted accidentally, it will usually split open and smoke, leaving very little doubt about its condition. Recommended replacement μ 741 op-amps for the channel filters, precision detectors and low pass filters are the Texas Instrument SN72741P or 741C and the Signetics 741 "commercial". 8-pin minidip. The National LM741CP does not have a high enough slew-rate for locations Z2 thru Z25. If Z2 thru Z25 need replacement, factory-installed op-amps from the other locations should be used, and they can be replaced with lesser op-amps from another source.

Z1 - Not used. In early designs this location was an optional input low pass filter.

Z2 - Input Amplifier. Measure at TP2. ± 14 volts or more indicates that this stage is operating properly. Reducing the LEVEL pot setting will reduce the output of this stage. R1 is the feedback resistor and is nominally set a half-scale.

Z3 - Input Inverter. ± 14 volts, similar to output of Z2.

Z4, Z5, Z6 and Z7 - Mark and Space local oscillators and inverters. Square wave, switching from zero volts to -15 volts. May be measured at TP12 and TP13, which are the inverter outputs. If the inverters show output, the oscillators are functioning also.

Z8 and Z9 - Mixer Output Buffer Amplifiers. ± 15 volts. Mixer products can be seen "within" this signal at the mixing rate.

Q1, Q2, Q3 and Q4 - J-Fet Mixers. These mixers are best measured at the cathode (banded) end of diodes CR1, CR2, CR3 and CR4. This signal will be $+15$ volts with mixer products at the $+10$ volt level.

Z10, Z11 and Z12 - Mark Channel Filters. The output of each of these stages is a symmetrical pulse representing the pulse sent by the RY generator. Amplitudes will vary between ± 12 and ± 8 volts. Measure at PC tab protruding from under socket, directly below Pin 6.

Z18, Z19 and Z20 - Space Channel Filters. Same as Mark channel filters above. A comparison of the Mark and Space filters complimentary sections will indicate whether the op-amp is working properly.

Z13 and Z21 - Filter Output Buffer Amplifiers. ± 15 volt pulses. May be flat-topped by limiting in these stages, but this is not important. Output level of the two buffers should be similar in appearance and within 1 DB of each other

Z14, Z15 Z22 and Z23 - Precision Detectors.

Z14: +13 volts, half wave pulses.
Z15: -7 volts, half wave pulses.
Z22: -13 volts, half wave pulses.
Z23: +7 volts, half wave pulses.

Z16 and Z17 - Space Low Pass Filter. Sine Wave, zero to -4 volts.

Z24 and Z25 - Mark Low Pass Filter. Sine Wave, Zero to +4 volts.

Z26 - Multipath Combiner Amplifier. Measure output at TP3. With LEVEL control at SUP, 9 volts peak to peak (+4 volts to -6 volts). Turn Level control to full CCW (zero signal input). Output at TP3 should be -0.4 volts. This -0.4 volt level may be adjusted with the Combiner Offset adjustment at R221.

Z27 - Space Buffer Amplifier. Read at junction of C36 and C37. 12 volts, peak to peak, sine wave, with a DC offset of +3 volts.

Z29 - Mark Buffer Amplifier. Read at junction of C38 and C39. 12 volts, peak to peak, sine wave, with a DC offset of -3 volts.

Z28 - Space Slicer. +15 volts square wave at TP4.

Z30 - Mark Slicer. +15 volts square wave at TP5 with the MULTIPATH CORRECTOR™ switch on front panel in UP position (ON). Zero volts with the MULTIPATH CORRECTOR™ switch in the OFF position. Return the MPC switch to the ON position (UP).

Z31, Z32, Z33 and Z34 - MULTIPATH CORRECTOR™ CIRCUIT. With front panel MPC switch turned ON (UP) and with a 15 MHz or faster test oscilloscope, read signal at Pin 8. This signal is also available at the cathode end (banded) of diodes CR23, CR24, CR25 and CR26. This signal should be setting high (+15 volts) with a series of negative going pulses (spikes) descending to zero volts. Lesser spikes (staying over 8 volts) are of no consequence.

If the test oscilloscope is not fast enough to display these spikes, check for a square wave signal at Pin 9 of each chip, which should be switching between +15 volts and Zero volts.

A square wave signal at Pin 8 indicates a faulty chip.

Turn the front panel MPC switch to OFF (Down).

Z31 and Z32 (CR23 and CR24) should test as above.

Z33: Pin 8, +15 volts, and Pin 9, zero volts.

Z34: Pin 8, +15 volts, and Pin 9, +15 volts.

Return front panel MPC switch to ON (UP).

This test verifies all 16 gates of the MPC. A "slow chip will not display the high speed negative-going pulses and should be replaced. Test oscilloscopes with less than 15 MHz of bandwidth probably will not register these pulses at all.

Z38 and Z48 - Mark and Space Channel LED Drivers.

If the front panel Mark and Space LEDs are flashing, the op-amp drivers are okay.

Pin 6 of either op-amp will display a pulse similar to a channel filter pulse with one side clipped at 3.5 volts, due to the clipping action of the LED diode. This is an AC circuit and the polarity of the LED is not important. Replacement LEDs may be installed with either polarity.

Z37 - Signal Loss Circuit. The output of this circuit may be checked at the rear panel SIGNAL LOSS connector (J11). The output is nominally -10 vdc and shifts to +10 vdc when the front panel LED indicates that the signal has been lost.

Improper operation of this circuit often indicates a problem in a preceding stage: Z26, Z36, Z38 or Z39.

If the Signal Loss circuit is operating properly it will respond in the following manner:

- 1) LEVEL control SUP and Standby switch ON = Signal Loss LED OFF*.
- 2) LEVEL control SUP and Standby switch OFF = Signal Loss LED ON*.
- 3) LEVEL control CCW and Standby switch ON = Signal Loss LED ON*.

*If the MPC-1000(C) has a bipolar red/green LED installed in this position, OFF will indicate green and ON will indicate red.

Z38 - Common Mode Amplifier. With LEVEL control SUP: ± 14 volts square wave, but not necessarily symmetrical. As THRESHOLD control is turned CCW, square wave should become symmetrical. With LEVEL control CCW (no signal): -14 volts.

Z39 - Automatic Mark/Hold, Anti-Space, Anti-CW and Anti-Mark/Fade (AMF).
This stage functions as a pulse width discriminator.
With Level control SUP: -15 volts.
With Level control CCW: +15 volts.

Z40 - Not used. In early designs, Z38 functioned as a DC coupled DTC and Z40 was required for some of the functions that are now performed by Z39.

Z41 - Autostart Driver Circuit, FSK mode.
With Level control SUP: +15 volts.
With Level control CCW: -15 volts.

Z42 - Autostart Relay Circuit Driver. This circuit should be checked in both FSK and MARK autostart modes.

Mark: Level control SUP: +15 volts. Level Control CCW: -15 volts.

FSK: With the mode switch in the MS-REV position, Pin 6 of Z42 will switch to +15 volts regardless of setting of the level control, due to coupling of Z45 thru CR34 to Z42.

Z43 - AFSK Tone Generator. Output of Pin 2 may be measured at TP10 and will be between 2 and 3 volts peak to peak with a positive DC offset between 2 and 8 volts. The keying voltage at Pin 9 should be a square wave from zero volts (less than 0.5 volts) to greater than 3 volts.

Z44 - Not used. In early designs this location contained an AFSK output buffer, which was susceptible to keying transients from the high level loop, and which has been replaced with C85, R148 and R149.

Z45 - EIA RS232C FSK Voltage Level Output. In the MS-REV mode: ± 15 volts square wave. In MS mode: -15 volts (Marking). This measurement may be made at the rear panel connector EIA J6.

Z46 - MIL STD 188C FSK Voltage Level Output. In the MS-REV Mode: ± 6 volts square wave. In the MS mode, +6 volts (Marking). This measurement may be made at the rear panel connector MIL J8.

Z47 - RY Generator (MS-REV). The output of Z47 may be measured at TP11. In the MS-REV mode: ± 15 volts square wave. In MS mode: Zero volts.

Q5 - Autostart Relay Keyer. Measure from collector (case) to ground. With Level control SUP, +20 volts unregulated (relay de-energized), and zero volts (relay energized).

Q6 - Loop Driver. Measure at REGEN OUT (J13) at rear panel. Level control SUP: Square wave, +13 volts to zero. LEVEL control at CCW: +13 volts.

Q7 - High Level Keyer. Measure Collector (case) to ground. Danger. High voltage (+130 volts). LEVEL control at SUP: Square wave, +250 volts to zero. LEVEL control at CCW: Zero volts. Flashing of the loop LED indicator indicates that the loop circuit is being keyed by Q7.

Q8 - Regulated +15 volts. Measure at TP9.

Q8 - Regulated -15 volts. Measure at TP7.

Q10 and Q11 - CRT Scope Channel Amplifiers. Measure at Collector (case). LEVEL Control at SUP: Channel filter type pulses of ± 50 volts with a +125 volt offset. With level control at CCW: +125 volts.

Q12 - CRT Dot Deflection Circuit. Measure at Collector (case) to ground. With LEVEL Control at SUP and Dot at center of CRT screen: Zero volts. With LEVEL Control at CCW and dot deflected to bottom of CRT screen: +200 volts.

If the dot does not deflect all the way to the bottom of the screen, the transistor at Q12 should be replaced.

To prevent dot deflection, maintaining the dot at all times in the center of the CRT screen, remove Q12 and jumper the collector to emitter socket pins.

DS1 - Loop Monitor LED Indicator. Measure green lead that comes from E35. With LEVEL at SUP: Square wave, zero to -2.0 volts. With LEVEL control at CCW: -2.0 volts.

DS2, DS3 and DS4 were checked previously with their associated circuits. Polarity of DS2 and DS3 is not important, since they are being driven by AC circuits. DS1 and DS4 are polarized with their longest lead toward the left side of the terminal unit. DS4 may be installed backwards and then will light on acquisition of a signal (AOS) instead of upon loss of signal (LOS). If a bipolar red/green LED is installed at DS4, it will be green with AOS and red with LOS. DS1 will not function if installed backwards.

Q13 - Automatic Threshold Level (ATL) circuitry. Q13 and R216 are located under the forward portion of the CRT.

With the LEVEL and THRESHOLD controls set for SUP and the mode switch in the MS-REV position, measure the drain (D) of Q13, which is the center lead of the device. The drain may also be measured at that end of R216 that is closest to the centerline of the terminal unit.

This voltage level should be -0.04 volts. Set the Level control to CCW (no signal condition) and the drain voltage level should shift to -0.18 to -0.20 volts.

SECTION XIII

TROUBLE SHOOTING HINTS

Experience has shown that 99% of all failures in the first 1000 hours of operation are due to infant mortality of the semiconductors.

For this reason, all semiconductors are mounted in low profile sockets.

Since Z46, MIL STD 188C FSK output generator, is very seldom used, it can be considered as a "spare", if needed. It can be replaced by any manufacturer's μ 741.

Likewise the transistor in the Dot Deflection Circuit (Q12) may be used as a spare for any of the five transistor locations. If used, add a jumper between the collector and emitter pins in Q12's socket, which will maintain the CRT's dot in the center of the screen.

All signal diodes (except the four 1N270s in CR44) may be replaced with any high speed silicon diode.

All power diodes should be replaced with a 1N4007 or equivalent.

If the terminal unit performs well in the MULTIPATH CORRECTORTM "ON" mode, but locks up with the MPC turned off, check the CMOS chips, Z31 thru Z34. If they check good, suspect Z27 and Z28.

If either the Mark or Space channel LED indicators stop flickering, although the TU appears to copy normally, do not assume the trouble is in the LED driver circuit or with the LED diode itself.

It is more probably an op-amp failure in one of the channel filters or one of its input or output buffer amplifiers.

The high performance of the MPC-1000(C) as a single channel In-Band Diversity TU automatically covers up the loss of one channel, but error rates will increase when the one working channel takes deep fades.

If the CRT Cross Display indicates a channel, but that channel's LED does not flicker, suspect one of the output buffers, Z13/Z21.

If both CRT and LED indicator for one channel cease to function, suspect the input buffers (Z8 or Z9) and the op-amps in the that particular channel filter.

A simultaneous loss of gain in both channels indicates a probable failure in the input inverter stage, Z3. Loss of gain only one channel (half power) is probably a bad op-amp at Z5 or Z7, or a failed J-Fet at Q1 thru Q4.

SECTION XIV

SPARE PARTS INFORMATION

There are no special or hard-to-get components used in the Dovetron MPC-1000(C) Terminal Units. A few items are proprietary to Dovetron and are available on a postpaid (USA) basis and will be shipped via UPS. COD orders will not be accepted for these items:

Power transformer:	WDI-7827B.	\$20.00
Front panel:	Specify Amateur/Comm.	\$30.00
CRT bezel:	Painted, flat black.	\$15.00
Side plate:	Rackmount or tabletop.	\$10.00/set.
Audio transformer:	600 Ω input.	\$6.00
IC Op-amp:	μ 741C, minidip, plastic.	\$0.75 each.

All operational amplifiers are tested for slew rate, low offset voltage and low input bias current.

The Texas Instrument and Signetics devices are preferred, because of their slew rate, which is required in the channel filters, precision detectors and low pass filters.

As other manufacturer's op-amps become suitable they may be used.

All standard components (except the PC board) may be ordered from Dovetron, although they are probably available from local, domestic sources. Where pricing is not published, these items may be ordered COD.

The Plessey capacitors may be replaced by dipped silver-micas, type CMO6 and DM20.

~~Spare CRTs are available only to the original purchasers of the MPC-1000 and MPC-1000C at \$25.00 each postpaid.~~

CRTs are not returnable from credit. Each CRT is checked before shipment for proper performance and insured with the shipping carrier for full value.

A \$5.00 deposit is required with all COD orders, and minimum billing charges are \$5.00.

PRICES AND SPECIFICATIONS SUBJECT TO CHANGE WITHOUT NOTICE.

SECTION XV

RECOMMENDED SPARES AND PROVISIONING

The following items and quantities are based on 24 hours continuous duty operation in environments of 0°C to 50°C and 90% Relative Humidity without condensation, and will support five Dovetron MPC-1000C Terminal Units for 12 months.

2 each	Potentiometer, A&B, JAIN056S202UA, 2.0K Ω , 10% tol.
1 each	Potentiometer, A&B, Type J-Locking, 5.0K Ω , 10% tol.
2 each	Capacitor, Sangamo, 066HJ400T350B, 40 Mfd, 350 VDC.
1 each	Capacitor, Sangamo, 066HL400T450B, 40 Mfd, 450 VDC.
2 each	Capacitor, Rubycon, Type TW, 1000 Mfd, 25/35 VDC.
4 each	Diode, germanium, TI, 1N270.
4 each	Diode, silicon, TI, 1N914, 1N4148 or equiv.
5 each	Diode, power silicon, TI, 1N4005.
5 each	Diode, power silicon, TI, 1N4007.
4 each	Transistor, high voltage, NPN, TI, 2N3439.
2 each	Transistor, low voltage, NPN, TI, 2N697.
2 each	Regulator, voltage. Motorola, MC7815CP, +15 volts.
2 each	Regulator, voltage. Motorola, MC7915 CP, -15 volts.
4 each	Integrated circuit, CMOS, Motorola, MC14011AL.
2 each	Integrated circuit, EXAR, XR2206C.
4 each	Transistor, N-channel, J-Fet. Teledyne, U-1897E.
9 each	Operational amplifier, TI, SN72741P, 8-pin, minidip.
4 each	Diode, light emitting, Red. OPCOA, high dome, diffused.
1 each	Resistor, power, Ohmite 0206, 1500 Ω , 25 watt, fixed.
1 each	Resistor, power, Centralab WN-102, 1K Ω , 5W, variable.
1 each	Switch, rotary, Centralab, PA-1021, 6 pole, 5 Pos, NS.
2 each	Jack, panel mount, Switchcraft 3501FP.
2 each	Jack, Nylon, Switchcraft, N114B.
2 each	Switch, toggle, miniature, ALCO, SPDT, MTA-106D.
1 each	Switch, toggle, miniature, ALCO, SPDT-CO, MTA-106E.
1 each	Switch, toggle, miniature, ALCO, DPDT, MTA-206N.
1 each	Relay, DPDT, Potter Brumfield, KA-3704 or KA11DG.
1 each	Transformer, Power. Wood Transformers, Inc. WDI-7827B.
1 each	Transformer, Audio. Triad/Utrad, TY-34X.
1 each	Tube, electron, CRT. RCA, Type JAN-2AP1A.

For 25 units, multiply all items by 3. For 50 units, multiply by 4.
For 100 units, multiply by 5.

The above items and respective quantities are based on field experience and assume that the Terminal Units will be serviced at a central location.

A spares kit is available from Dovetron that will support two MPC-1000C separately for 12 months. Consult factory for price and delivery.

SECTION XVI

PARTS LIST - E SERIES

<u>DESIGNATION</u>	<u>COMPONENT</u>
C17, C32.	390 Pfd, 5%, Silver Mica, CMO5FD.
C19, C34.	2000 Pfd, 5%, Silver Mica, CMO6FD.
C20, C35.	2400 Pfd, 5%, Silver Mica, CMO6FD.
C6, 7, 8, 9, 10, 11, 15, 16, 18, 21, 22, 23, 24, 25, 26, 30, 31, 33.	4700 Pfd, 5%, Mylar, Plessey 4N7J630, or Silver Mica, CMO6FD.
C40, 41, 42, 43.	0.001 Mfd, 20%, disc.
C44, 63, 64, 76, 79.	0.01 Mfd, 20%, disc.
C61, 62.	0.01 Mfd, 20%, 1KV, disc.
C4, C5. (MPC-1000)	0.047 Mfd, 5%, Mylar, Plessey .047J250.
C4, C5. (MPC-1000C)	0.056 Mfd, 5%, Mylar, Plessey .056J250.
C3, 12, 27, 52, 53.	0.1 Mfd, 5%, Mylar, Plessey 0.1J250.
C45, 46, 47, 48, 55.	1.0 Mfd, 5%, Mylar, Plessey 1J100.
C36, 37, 38, 39.	10 Mfd, 35 VDC, 10% tantalum dip.
C54, 83, 84.	1 Mfd, 20 VDC, 20% electrolytic.
C49, 51.	10 Mfd, 35 VDC, 20% electrolytic.
C60, 66.	40 Mfd, 350 VDC, electrolytic.
C67.	40 Mfd, 450 VDC, electrolytic.
C56, 57.	1000 Mfd, 25/35 VDC, electrolytic.
C1, C2, C13, C14, C28, C29, C68, C69, C70, C71, C72, C73, C74, C75, C58, C59.	These capacitor locations are not used in the MPC-1000(C) E-Series.
CR1 - CR36, CR38 - CR41, CR50, 51, 52, 53, 54, 55, 58.	Diode, silicon, signal, high-speed, Types 1N914, 1N3600, 1N4148, or equiv.
CR37, 42, 43, 45, 60, 61.	Diode, silicon, power, 1N4005.
CR46, 47, 48.	Diode, silicon, power, 1N4007.

DESIGNATIONCOMPONENT

CR44.	Diode bridge, consists of four 1N270 Germanium signal diodes.
F1. (110 VAC mains)	Fuse, 3AG. 0.5 amp, slow-blow, 110 VAC.
F1. (220 VAC mains)	Fuse, 3AG. 0.25 amp, slow-blow, 220 VAC.
F2.	Fuse, 3AG. 0.1 amp, fast-blow.
F3.	Fuse, 3AG. 1/32 amp, slow-blow.
J1. (MPC-1000)	Jack, panel mount, Switchcraft 3501FP.
J1A. (MPC-1000C)	Jack, Nylon, audio type, Switchcraft N114B.
J2 thru J17.	Same as J1.
J18, J19.	Sames as J1A.
K1.	Relay, DPDT, 24 VDC, 10 amp contacts. Potter Brumfield KA3704, KAllDG or equiv.
DS1, DS2, DS3, DS4.	Indicator, LED, red, high dome, diffused.
P1.	Connector, power. Switchcraft, AC3G.
P2.	Connector, printer. Waber 3018B.
Q1, Q2, Q3, Q4.	Transistor, J-FET, N-channel. U-1897E.
Q5, Q6.	Transistor, NPN, medium power, 2N697.
Q7, Q10, Q11, Q12.	Transistor, NPN, high voltage, 2N3439.
Q13.	Transistor, J-FET, P-channel, 2N4360.
Q8.	Regulator, +15 volts, 1 amp. MC7815CP.
Q9.	Regulator, -15 volts, 1 amp. MC7915CP.

ALL RESISTORS: 5%, 1/4 WATT, CARBON FILM, UNLESS NOTED.

R167.	15 Ω
R170.	33 Ω
R87, 96, 108, 109.	120 Ω
R151.	200 Ω
R114, 149, 150, 158, 159, 160, 196, 219.	470 Ω
R187, 199A, 199B, 200, 204, 216.	1000 Ω
R168.	1500 Ω , 25 watt, vitreous (standard).
R168A, R168B.	3000 Ω , 25 watt, vitreous (optional).

<u>DESIGNATION</u>	<u>COMPONENT</u>
R132, 133, 197, 211, 212.	2000Ω
R143, R146.	2000Ω, 1%, metal film.
R31, R56.	2.61KΩ, 1%, metal film.
R28, 53.	2.87KΩ, 1%, metal film.
R43, 68, 84, 98, 134, 177.	4700Ω
R25, R50.	3.48KΩ, 1%, metal film.
R77.	12.4K, 1% metal film.
R2-R11, R13-R16, R18, R20,	10KΩ
R21, R38-R42, R63-R69, R74,	10KΩ
R76-R82, R86, R90, R91, R95,	10KΩ
R99-R107, R110, R115, R116,	10KΩ
R122, R123, R129, R142, R144,	10KΩ
R154-R157, R162, R164, R166,	10KΩ
R175, R181, R183, R189, R217.	10KΩ.
R161.	11KΩ.
R23, 52, 83, 85, 92, 94,	20KΩ
117, 127, 128, 148.	20KΩ
R113, 118, 140, 144.	30KΩ
R34, 59.	62KΩ
R35, 36, 37, 60, 61, 62, 88,	100KΩ
97, 111, 112, 130, 137, 138,	100KΩ
157, 165, 182, 202.	100KΩ
R119.	180KΩ (May be as high as 270KΩ).
R30, R55.	237KΩ, 1%, metal film.
R24, 49, 52.	301KΩ, 1%, metal film.
R178.	390KΩ
R27, R52.	402KΩ, 1%, metal film.
R121, 136, 149, 153, 176.	470KΩ
R26, R51.	604KΩ, 1%, metal film.
R29, 54.	806KΩ, 1%, metal film.
R32, 57.	715KΩ, 1%, metal film.
R214, 215.	1.0 megohm
R186.	3.0 megohm

DESIGNATIONCOMPONENT

R172A.	Not factory installed.
R33, 58, 124, 125, 126, 135, 185, 202, 203.	Not used in E-Series.
R145A, R147A, R172, R205.	2K Ω Pot, 10% tol. JA1N056S202UA.
R145B, R147B.	5K Ω , PC type, Piher PT15YB.
R206, R207.	5K Ω , pot, 10% tol. locking-type.
R163.	10K Ω , pot, PC, Piher, PT15YB.
R195.	100K Ω , pot, PC, Piher, PT15YB.
R173, R180.	250K Ω , pot, PC, Piher, PT15YB.
R1, R221.	500K Ω , pot, PC, Piher, PT15YB.
R191, 192, 193, 194.	500K Ω , pot, PC, CTS XR201R504B.
S1.	Switch, rotary, 6 pole, 5 position, non-shorting, Centralab PA-1021, or OAK Industries P/N: 527432113.
S2, S3, S5.	Switch, toggle, miniature, SPDT, ALCO MTA-106D, or equiv.
S4, S7.	Switch, toggle, miniature, DPDT, ALCO MTA-206N, or equiv.
S6.	Switch, toggle, miniature, SPDT/CO, ALCO MTA-106E, or equiv.
T1.	Transformer, power. Wood Trans- former, Inc., 810 Lemon Street, Calif., 92667. P/N: 7827B. Pri: 110/220 VAC, 50-400 Hz, 1 \emptyset . Sec: 1) 36 VAC, 1 amp, CT. 2) 130 VAC, 100 Ma. 3) 350 VAC, 50 Ma. CT. 4) 6.3 VAC, 1 amp.
T2.	Transformer, audio input, 600 Ω . Triad/Utrad TY-34X.
V1.	Tube, electron, CRT. RCA-JAN2AP1A.
Power Cord.	Belden 17258-S, three wire.
Z2-Z30, Z35-Z39, Z41, Z42, Z44, Z45, Z46, Z47.	Integrated circuit, linear, μ 741C. 8-pin, minidip, plastic. TI-SN72741P, or equivalent.

DESIGNATIONCOMPONENT

Z31, Z32, Z33, Z34.	Integrated circuit, digital, CMOS, MC14011AL or CD4011AE, ceramic.
Z43.	Integrated circuit, monolithic, Exar Corp., type XR2206C.
PC-1	Photocell, Vactec VT-343.
R77.	12.4K Ω , 1%, metal film.
R169.	1K Ω pot, 5 watt, Centralab WN102.
Chrome Handle.	Amitom 10205B0632.
CRT Bezel.	A. L. Johnson, Monrovia, Cal. P/N 383, Revision C.
Knob, Small.	Kurz-Kasch S-1647-1L.
Knob, Large.	Kurz-Kasch S-1653-1L.
CRT socket.	Alden Products 211FSC (2AP1A).
CRT shield.	Millen Mfg. Co., 80802-126.
F1, F2 fuseholder.	Littlefuse 342004A.
F3 fuse clip.	Bussman 1A1119-10.
Socket (PC-1)	H. H. Smith 6265.
Socket (Transistors)	Cinch Jones 3LPS-B.
Socket (8 pin IC)	Texas Inst., C830802.
Socket (14 pin IC)	Texas Inst., C831402.
Socket (16 pin IC)	Texas Inst., C831602.
Feet (cabinet)	3M Products, SJ5023.
Cabinet assembly	Intrafab, San Jose, Cal. MCLS-3179.
Side plate, table top.	Intrafab, SPH-39.
Side plate, rack mount.	Intrafab, SPHR-39.
Printed Circuit Board	Dovetron A75100E.
Support Bars (PC board)	Dovetron CS-1.

SECTION XVII

WARRANTY

DOVETRON warrants all parts, labor and quality of construction for twelve (12) months from the date of shipment, except no warranty is extended to the Cathode Ray Tube.

During this 12 month warranty period, a defective MPC-1000(C) will be repaired or replaced at DOVETRON's discretion, at no charge.

All Terminal Units returned for warranty service must have shipping charges prepaid.

No units will be accepted on a freight-collect basis.

For fast, prompt warranty service, please notify DOVETRON prior to shipment, that unit is being returned for warranty service.

State clearly all suspected or confirmed problems.

Enclose a statement of problems with the instrument.

Provide a return address in original correspondence and with the returned instrument.

Upon completion of warranty repair, normally within 24 hours, the terminal unit will be returned to sender Freight-Collect. This shipping charge may be prepaid: \$7.50 Continental USA.

NON-WARRANTY REPAIRS

Terminal Units returned for non-warranty repairs will be billed for parts and labor. The labor rate is \$18.00 an hour. Normal wear and tear (scratched panels, lids, etc.) will not be repaired or replaced unless specifically requested.

WARRANTY WAIVERS AND EXCEPTIONS

The user is encouraged to repair his terminal unit and will not invalidate the 12 month warranty, if due caution and respect is used. Soldering irons with power ratings in excess of 20 watts should not be used on the PC board.

Defective parts returned to DOVETRON during the warranty period will be promptly replaced. Spare parts orders are normally filled and shipped the same day as received.

WARRANTY, PRICES AND SPECIFICATIONS SUBJECT TO CHANGE WITHOUT NOTICE.

SECTION XVIII

NOTES

REGENERATION

When in the Transmit mode with a peripheral Regenerator/Speed Converter, the high level keyer (Q7) must be locked into the Mark condition.

This is easily done by supplying a constant +5 to +15 volts to the REGEN IN port (J12) from the peripheral via the cable interconnecting J12 to the peripheral, during TRANSMIT.

This may also be accomplished if the peripheral automatically reconnects J12 and J13 when in the Transmit mode, permitting the Automatic Mark Hold circuit within the terminal unit to lock the high level keyer into Mark.

A remote contact closure ground to E65 also locks the high level keyer into Mark. The contacts must be capable of handling 60 Ma. at 130 VDC.

SIGNAL LOSS LED

The Signal Loss LED on the front panel will flicker when the terminal unit is switched to Standby and has an input signal present. Even if the signal is too weak to light the Mark and Space LEDs, the Signal Loss LED will indicate that the terminal unit is processing a signal, but the Standby switch is inhibiting the high level keyer circuits.

ADDITIONAL EIA RS-232C FSK OUTPUT

If the EIA FSK output at J6 is dedicated to driving a teleprinter, regenerator, etc., and an additional EIA FSK line is required, the MIL STD 188C FSK output at J8 may be converted to EIA characteristics by removing Z46 from its socket. The output impedance of this second EIA line will be 31K ohms, the sum of R155, R156, R157 and R158. This impedance may be lowered by modifying the values of R155-R158 accordingly.

AUTOSTART "IMMEDIATE" TIME-OUT

Sometimes (particularly during servicing) it is convenient to manually force the autostart to zero and de-energize the time-out relay. This can be accomplished by momentarily turning the main power switch Off and then right back On. The negative bias on the time constant circuits will reset them to zero and de-energize the autostart relay.