

# *Modification of TVRO LNBS for 10 GHz*

---

*Applying consumer electronic equipment to Amateur  
Radio has a long tradition—but at 10 GHz? Yes!*

---

By Paul Wade, N1BWT, and Don Twombly, WB1FKF

**D**irect-broadcast satellite TV service using small dish antennas has recently become available in the US. The frequencies used for these broadcasts are in the 11 to 12-GHz range, so it seems natural to wonder if any of the equipment is usable for the 10-GHz amateur band. The small parabolic dishes are obvious candidates that work well.<sup>1</sup> And we found that the LNB (low-noise block downconverter) units used in these systems are easily converted to excellent 10-GHz preamplifiers.

During the past year, several types of LNBS have appeared at hamfests. We were able to acquire several at

quite reasonable prices, allowing us to attempt modifications knowing that even if we were unsuccessful, we could probably salvage enough components to justify our investment.

An LNB contains a number of small surface-mount microwave components in a small space—Figs 1 (cover and shielding removed) and 2 (partially modified) are photographs of the interior of two typical units. All the units we have looked at have the same basic block diagram, shown in Fig 3. A waveguide fitting, which bolts to the feedhorn, is part of the metal casting that forms the LNB housing. A probe in the waveguide makes the transition to the microstrip circuitry. Since waveguide has no dc connection, no blocking capacitor is needed, and a direct connection is made to the input

of a three-stage, low-noise amplifier. The first stage, typically marked with a red dot, is probably a very low-noise transistor such as an HEMT. The amplifier is followed by a printed filter, then a diode mixer. A dielectric-resonator oscillator (DRO) operating at 10.75 GHz provides the LO for the mixer. The rest of the circuitry is on the reverse side of the units, so it is not visible in the photographs. It consists of voltage regulators and bias circuits for the GaAsFETs and a 900 to 1300-MHz postamplifier following the mixer. (We haven't yet tried one of these at 1296 MHz, but expect good performance.) The type-F output connector also supplies the power to the LNB.

Since it is very difficult to retune a printed filter, our first modification involved bypassing the printed filter with a length of semirigid coax, as shown in Fig 4, to isolate the low-noise

<sup>1</sup>Wade, P., N1BWT, "Practical Microwave Antennas, Part 2", *QEX*, October 1994, pp 13-22.

amplifier. Since the gaps in the printed filter provided the original dc isolation, a chip capacitor is now required as a dc block for the output coax. We also removed power from the oscillator and the postamplifier by disconnecting jumper wires. We then measured the low-noise amplifier with a waveguide-to-coax adapter at the input. It had greater than 25 dB of gain from roughly 11 to 12.5 GHz but rolled off about 10 dB at 10 GHz.

Since it appeared that the 10-GHz gain was reduced by high input SWR, we took a hacksaw to the waveguide flange and replaced the probe with an SMA connector, as shown in Fig 5. The Teflon dielectric of typical SMA connectors is the same diameter as the

dielectric surrounding the probe, so fitting the connector was straightforward. Since there is now a dc connection, a blocking capacitor is again necessary—a 1-pF microwave chip capacitor worked better than a larger value.

With coax connectors at both ends, the low-noise amplifiers have high gain from roughly 9 to 13 GHz, with typically 30 dB of gain at 10.3 GHz. The noise figure is also very good, typically 3 dB or lower with no tuning. Some types of LNB need additional tuning, performed by trimming the microstrip lines and adding metal flakes, which you can do if you have the facilities for measuring noise figure. After a bit of tuning, the typical noise figure is around 2 dB. Don's best unit measured

1.6 dB at the 1994 Eastern VHF/UHF Conference, with no tuning.

A preamp with this kind of performance is more than adequate for almost all 10-GHz work. A noise figure under 3 dB is fine for most terrestrial contacts, and 30 dB of gain is plenty to mask the noise of any decent mixer. In fact, during testing, the output cable on one unit developed a short circuit, but the noise figure only increased by 1 dB!

We won't attempt to give specific modification instructions since there are so many types available, and the modifications are mainly a matter of mechanical ingenuity. For instance, the LNB shown in Fig 2 has a convenient place near the printed filter to

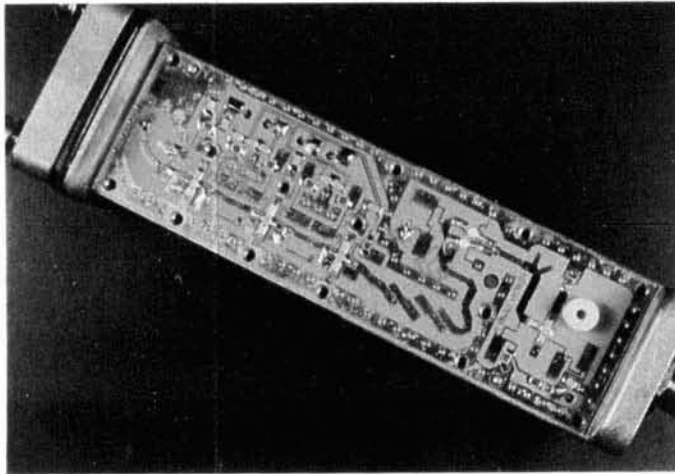

Fig 1

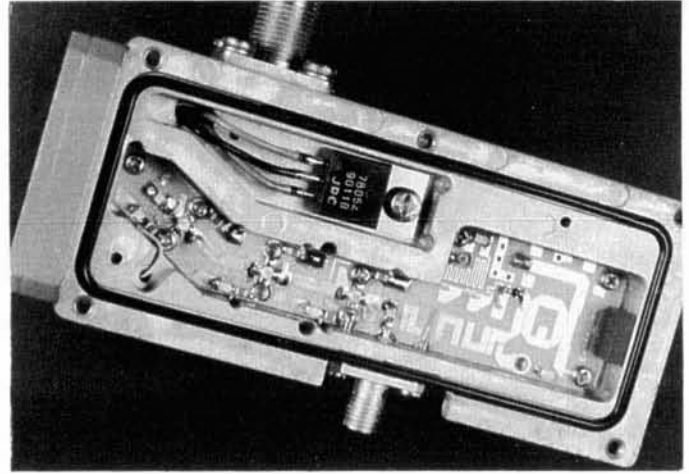

Fig 2

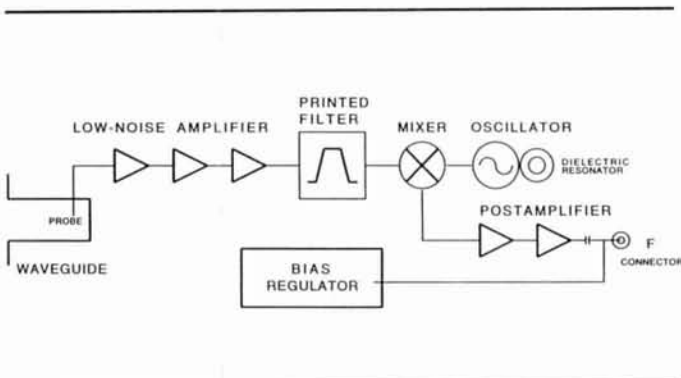

Fig 3—Block diagram of a typical TVRO LNB.

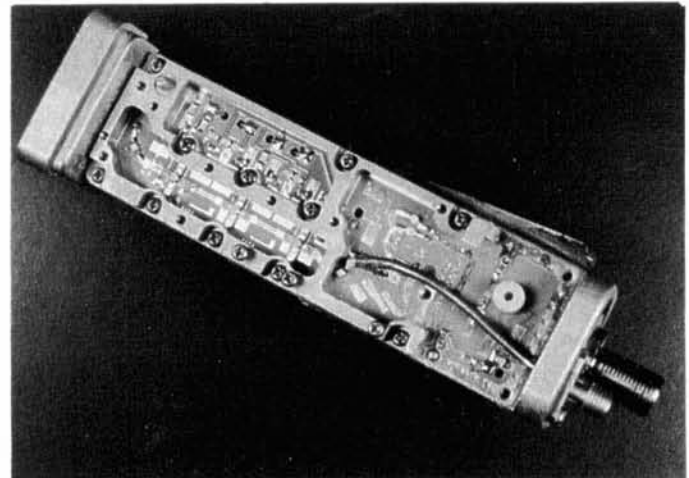

Fig 4

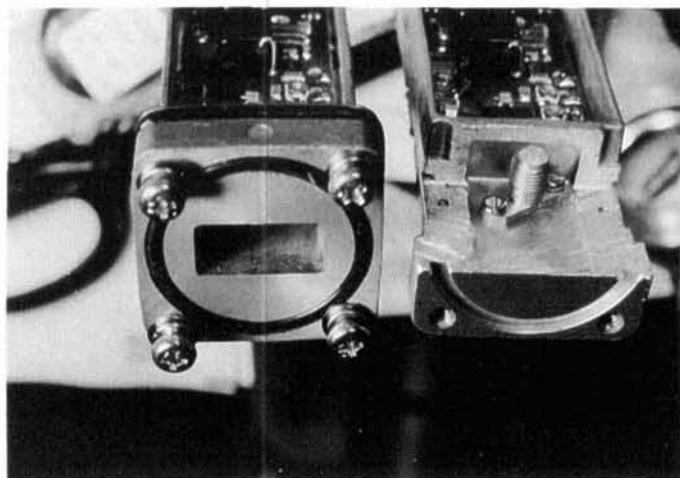

Fig 5

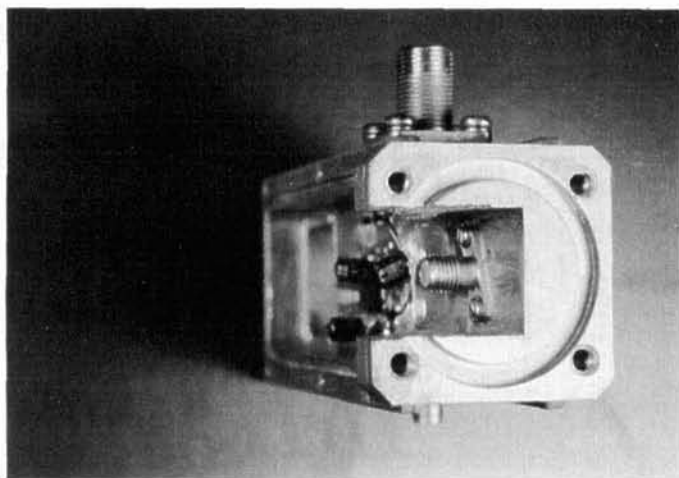

Fig 6

mount an output connector, after a bit of work with hacksaw and file, eliminating the need for semirigid coax. Modification of the input waveguide, shown in Fig 6, is not quite the same as for the unit shown in Fig 5, but is also accomplished with a hacksaw.

The holes for the SMA connector mounting screws are easily tapped in the cast aluminum housing, but the location should be chosen carefully to

avoid drilling through components or microstrip lines. Drilling is best accomplished with a drill press, and judicious use of masking tape can help keep metal chips from landing in unwanted locations.

Direct-broadcast satellite TV systems are predicted to become inexpensive consumer products, so components like the LNB and dish will probably be readily available. Already, a

brand new LNB with extremely low-noise figure sells for less than \$100.

The modifications we have described only use the most valuable part of the LNB, the low-noise amplifier. The other parts can be removed for other uses.

It might even be possible to phase-lock the internal oscillator to a stable reference to make a complete 10-GHz converter. □

**CALL ROSS 208-852-0830**

**WE TAKE TIME TO TALK TO YOU**

**We're Stocked To The Ceiling**

TIMEWAVE TECHNOLOGY		ALINCO CORPORATION		MFJ		ICOM		BC80A	
<b>INC</b>		DJ-F1T	\$255.00	MFJ-949EY	\$112.50	R-900A	\$6,825.00	BP21	115.50
DPS-9+	\$205.00	DJ-G1T	285.00	MFJ-815B	45.00	IC-4KL	6,750.00	BP22	17.00
DPS-59+	288.00	DR-119T	336.00	<b>ROBOT</b>		IC-761	2,150.00	BP-23	25.00
<b>AEA</b>		DR-1200T	272.50	800-CH	\$400.00	IC-21A	285.00	BP-70	48.00
PK232MBX	\$285.00	DR-599T	589.00	800H	300.00	IC-245	269.99	CP-12	27.00
PK-900 HF/VHF	464.50	DR-600T	650.00	<b>TEN-TEC</b>		IC-275H	1,475.00	EX108	120.00
MP-20	39.99	DR-600T(B)	577.50	535	\$1,100.00	IC-281H	377.50	DELTA-1A	770.00
PK-64A/HFM	145.00	EBP-12NA	52.00	604	100.00	28H	345.00	HM-46	45.50
HR-1 1/2	20.00	EDC-34	92.00	425	2,500.00	IC-2330A	803.50	HM-65	42.50
CP-100	246.99	EJ-8U	45.50	<b>KENWOOD</b>		IC-2340H	610.00	LC-14	11.50
MP-64	90.00	EMS-8Z	45.50	TM-411A	\$330.00	IC-4SAT	366.00	MB-27	20.00
PM-1	95.00	<b>YAESU</b>		TS-505	1,045.00	IC-575A	1,200.00	O4AT	250.00
PK-12	112.50	FT-415/25B	\$324.00	TR-8400	315.00	IC-707	795.00	RC-11	80.00
HL-60	224.50	FT-416G/25-B	299.00	TM-2515	408.00	725	780.00	IC-UT63	75.00
VSB-70	380.00	FTS100B8	620.00	TM-241A	345.00	IC-728	1,020.00	UX-39A	516.00
<b>STANDARD</b>		FT-51R	495.00	TS-450SAT	1,300.00	729	1,200.00	UXS92A	679.00
C5608DA	\$784.50	FT-703R	260.00	TH-41BT	220.00	IC-735	1,170.00	IC-W2A	420.00
C528A	413.50	FT-709R	300.00	TH-79A	418.00	IC-737	1,240.00	<b>KANTRONICS</b>	
<b>ASTRON</b>		FT-726R 2MU	350.00	TH-315A	340.00	IC-737A	1,470.00	KAM	\$230.00
RS-20A	\$87.90	FT-73R 7	240.00	RM-76	45.00	IC-970H	2,975.00	KAM PLUS	300.00
RS-35A	140.00	DT-770RH	350.00	PB-10	40.00	AG-1	80.00	AMORSOFT C64	40.00
RM-35M	237.90	FT-780	650.00	EB-2	24.50	AG-35	137.00	AMTORSOFT VIC-20	30.00
RS-7B	50.00	FT-900/AT	2,332.00	TS-950SD	2,995.00	AH-3	530.50	1005 VARIFIER	60.00
RS-12A	69.00	G-1000SDX	456.00	<b>LESS ANY VALID COUPONS</b>		AT-160	385.50	MI-T MINI TERM	150.00
RM-50A	222.00	FT-2500M	360.00			BC-50U	40.00	KT-110 10M SSB	320.00



**Ross Distributing Company**

P.O. Box 234, 78 South State Street, Preston, Idaho 83263  
Telephone 208-852-0830

Hours  
Tuesday-Friday 9:00-8:00  
9:00 - 2:00 Mondays