

A Single-Board Transverter for 5760 MHz and Phase 3D

*Pipe-cap filters and advances in MMICs
place 5760 easily with your reach.*

By Paul Wade, N1BWT

Introduction

Single-board transverters account for most of the activity on the microwave bands below 5760 MHz, but there has been a dearth of high-performance designs for higher bands. This transverter provides the compact convenience of a single-board unit without compromising performance, making it easy to get on 5760 MHz or the coming Phase 3D satellite without requiring scarce surplus components.

The main reasons for the scarcity and complexity of previous transverter designs for this band are a lack of suitable inexpensive gain devices and the diffi-

culty in making printed filters. For instance, the only single-board transverter article to date, by KK7B,¹ was simply a bilateral mixer and printed filter; a high IF, 1296 MHz, was required because of poor filter selectivity.

Recently, the availability of inexpensive GaAs and heterojunction bipolar silicon (ERA-series) MMIC devices has solved the gain problem, and pipe-cap filters² offer a good alternative to printed filters. In a previous 5760 MHz article,³ I suggested that the next improvement would be to add a transmit and receive amplifier stage to that dual-mixer board. This article goes a step further, by including a multiplier chain for the local oscillator and enough amplifier stages to

make a complete transverter station.

Description

The heart of this transverter is the printed-circuit dual mixer,³ a design that has worked well for several years—a number are in use. The receive mixer is augmented with a GaAs MMIC preamplifier preceding the pipe-cap filter. This preamp provides good noise figure with adequate gain. The transmit side has two stages of gain with two pipe-cap filters. One follows the mixer and there's one between the MMIC devices, to adequately filter out the LO and image signals. The LO chain consists of three active stages separated by filters: an MMIC working as a times-10 frequency multiplier, followed by a pipe-cap filter, an MMIC amplifier, a second pipe-cap filter, and another

¹Notes appear on page 14.

MMIC amplifier to raise the power to the level required for the mixers. The MMIC devices keep the schematic diagram in Figure 1 straightforward enough so that a separate block diagram is not necessary.

The local oscillator input, at

561.6 MHz (or 552.4 MHz for Phase 3D), comes from the same KK7B local oscillator board⁴ used in lower-frequency single-board transverters. These boards are readily available and work so well that no alternative was seriously considered. When I built

the LO board, I calculated the resistor values for operation at 9 V, so that it would operate at the same regulated voltage as the rest of the transverter. I also carved out a small block of Styrofoam to fit around the crystal for better thermal isolation, in the hope

5760 MHz SINGLE BOARD TRANSVERTER

FIGURE 1

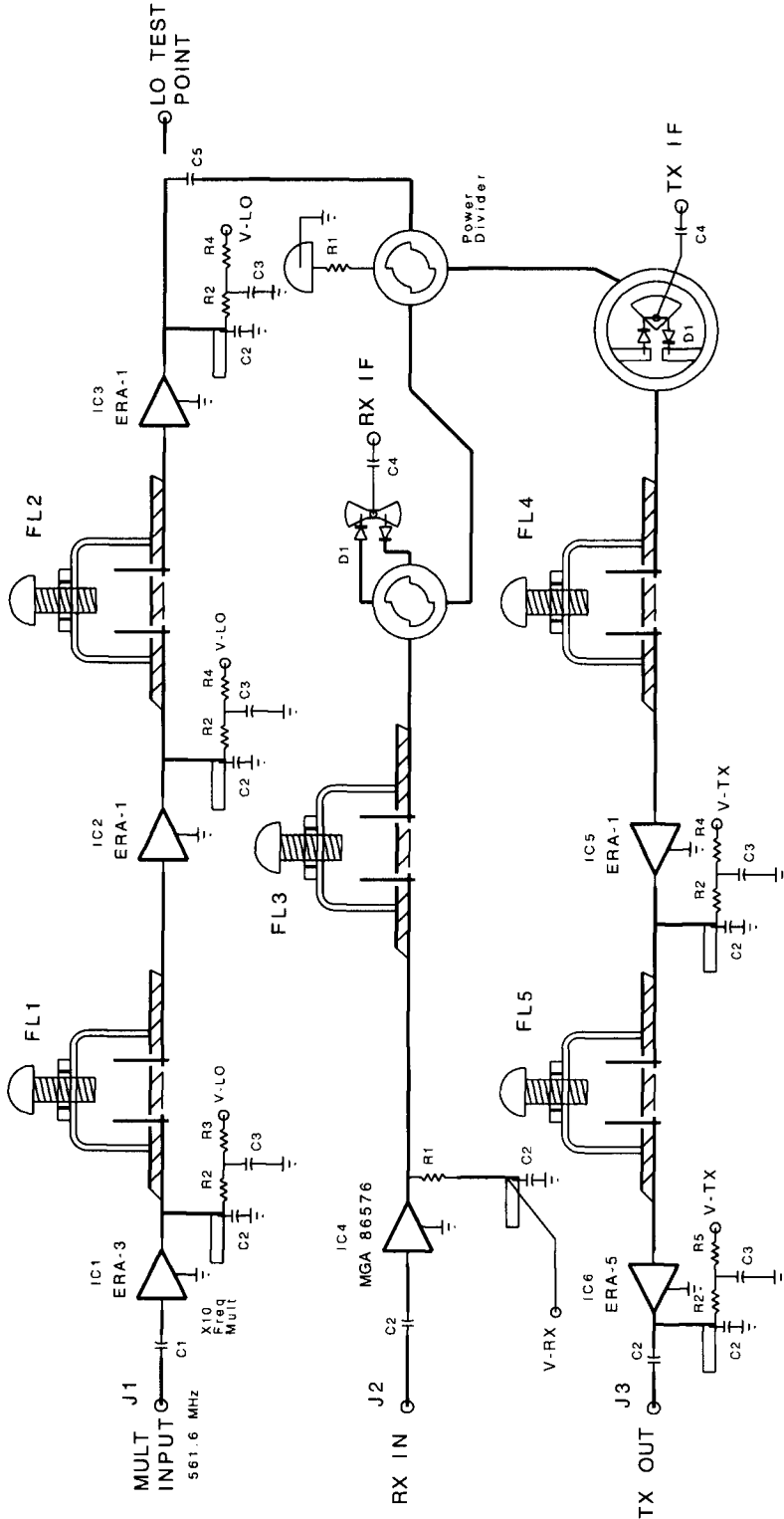

N1BWT 1997

PARTS LIST

- | | | | |
|-----|----------------------------|---------|-------------------|
| C1 | 100 pf chip | R1 | 50 Ohm chip |
| C2 | 8.2 pf chip - ATC | R2 | 27 Ohm chip 1/8W |
| C3 | 1000 pf chip | R3 | 180 Ohm chip 1/8W |
| C4 | 1000 pf | R4 | 82 Ohm chip 1/8W |
| C5 | 8.2 pf chip - ATC | R5 | 33 Ohm chip 1/8W |
| D1 | HSMS-8202 MIXER DIODE PAIR | IC1 | ERA-3 MMIC |
| FL1 | ERA-1 MMIC | IC2,3,5 | ERA-1 MMIC |
| FL2 | MGA-86576 MMIC | IC4 | MGA-86576 MMIC |
| FL3 | ERA-1 MMIC | IC6 | ER-5 MMIC |

of better frequency stability.

Multiplier

The new ERA series of MMIC devices from Minicircuits⁵ offer usable gain up to 10 GHz at low cost, so they were obvious choices for the amplifier stages. However, an article by NØUGH,⁶ which described using the ERA-3 as a frequency multiplier for 10 GHz, showed additional possibilities. Using a hobby knife, I made a breadboard of an ERA-3 followed by a pipe-cap filter on a scrap of Teflon PC board to test the multiplier performance. A 3/4 inch pipe-cap filter can be tuned roughly from 4 to 7 GHz, so I tuned it to several different frequencies and varied the input frequency and power with a signal generator to try various multiplication factors, from $\times 4$ to $\times 15$. The results, plotted in Figure 2, show pretty good multiplier performance, but the curves have too many ups and downs for predictable performance.

While I was trying to understand the data in Figure 2, Steve, N2CEI, suggested that an article⁷ on MMIC frequency multipliers by WA8NLC might offer some insight. The article referred me to Hewlett-Packard application note AN-983,⁸ which describes how diode-frequency-multiplier performance is affected by the phase shift of the transmission line length between the diode and filter. Since WA8NLC showed that the same phenomenon applies to MMIC frequency multipliers, I calculated electrical line lengths for my breadboard and replotted the data as shown in Figure 3. Now we can see that some multiplication factors are more affected by line length than others, and we can design to optimize for the desired multiplication factor. Figure 3 also shows the $\times 10$ multiplication used in this transverter to be relatively insensitive to line length; the output power change with output line length can be attributed to increasing multiplication factors.

Filters

Printed-circuit filters are not suitable for two reasons: Dimensions become very critical at bandwidths less than 10%, and radiation from them increases at higher frequencies (where the board thickness is a significant fraction of a wavelength). In a recent 3456 MHz design⁹ KH6CP (now W1VT) used thinner Teflon PC material to reduce radiation from the filters, however, this requires that dimensional tolerance also be reduced proportionally—to the point where printed pat-

terns would not be reproducible. If high-Q structures like printed filters are eliminated from the board, radiation is reduced, and then the thicker dielectric material is usable.

The pipe-cap filters² are made with readily available copper plumbing fixtures and offer good performance but require tuning. My previous experience⁴ showed that a single pipe-cap filter did not provide adequate LO rejection at 5760 MHz, so multiple filters were required. I was uncertain whether it would be possible to tune up multiple filters without sophisticated test equipment, so I tested the tuning on the multiplier breadboard. I found that the tuning screw varied the frequency by 300 to 400 MHz per revolution, or about 1 MHz per degree of rotation. Also, the

frequency could be set repeatably by measuring the height of the tuning screw. So, it is possible to preset the tuning screws close to the desired frequency, or to easily retune from 5760 MHz to 5668 MHz for Phase 3D. The difference in tuning should only be about one quarter of a turn, but the filters are sharp enough that retuning is required. Finally, since the filters are separated by amplifier stages, it is possible to tune them individually with minimum interaction.

Construction

Layout of the printed circuit board is shown in Figure 4. All components except the pipe-cap filters go on the top surface, as shown in the photograph, Figure 5. The pipe caps are soldered

Figure 2. ERA-3 Frequency Multiplier

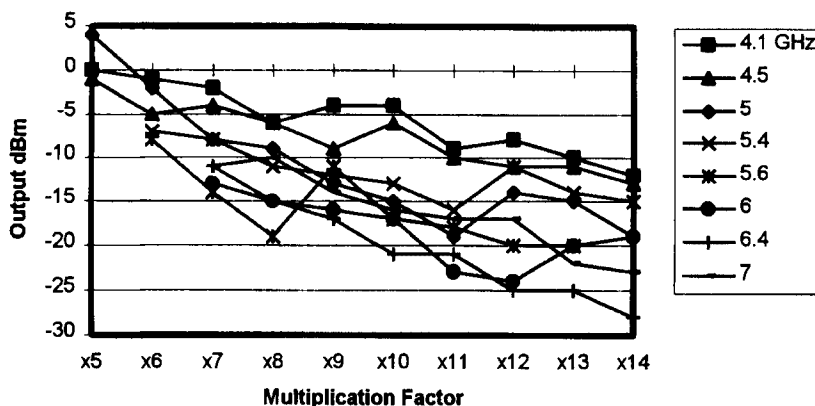
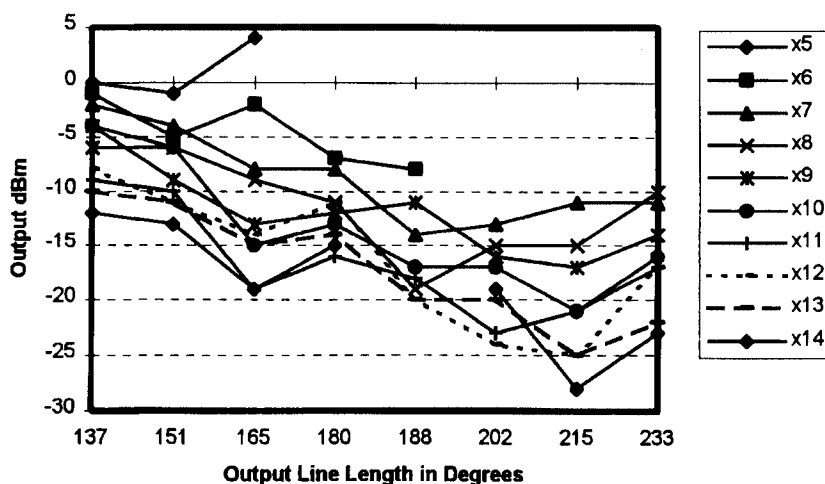

Figure 3. ERA-3 Frequency Multiplier



on the ground plane side. Since a torch is used to solder the pipe caps, it is a good idea to install them first, but not until all holes are drilled and a clearance area is cut in the ground plane around the probe pins for the filters.

A pipe-cap filter sketch is shown in Figure 6. This is the procedure I use to install the pipe-cap filters: in preparation, I drill tight-fitting holes for the probes and make clearance holes in the ground plane around the probe holes. For each pipe cap, I measure from the holes and scribe a square on the ground plane that the pipe cap just fits inside. Next I prepare each pipe cap by drilling and tapping (use lots of oil) the hole for an 8-32 tuning screw, then flattening the open end by sanding on a flat surface. Then I apply resin paste flux lightly to the open end, and to the area around the screw hole for a brass nut to extend the thread length as shown in Figure 6. The nut is not necessary, but it makes tuning smoother. The nut is held in place for soldering with a temporary stainless-steel screw. (Solder won't stick to it.) Next I center the open end of each cap in a scribed square on the PC board — the flux holds it in place. Finally, I fit a circle of thin wire solder around the base of each pipe cap and nut. The caps are soldered one at a time, starting with the center one. I hold each cap down with gentle pressure and heat it for a few seconds with a propane torch until the solder melts and flows into the joints, then let the solder harden before releasing pressure. Don't be shy with the torch—melt the solder quickly and remove the heat. Keep the flame on the top of the pipe cap to avoid damage to the PC board.

For the coupling probes, I use brass escutcheon pins that are $\frac{1}{32}$ " in diameter. The desired probe length inside the pipe-cap filter is $\frac{1}{4}$ ", so I cut them to a length of $\frac{9}{32}$ ", not counting the head, to compensate for the PC board thickness. The probes are not installed yet, but rather as part of the tune-up procedure. To install them, I put a small amount of flux under the head of each pin, then insert it into the tinned hole and solder.

The 5760 MHz end of the board, with J1, J2 and J3, needs a robust way to attach the connectors. The PC board was planned to fit into an extruded aluminum box (made by Rose Enclosure Systems) that is available from Down East Microwave.¹⁰ The box is supplied with aluminum endplates, but I believe that the PC board ground plane must be soldered to the endplate around the connectors to provide a

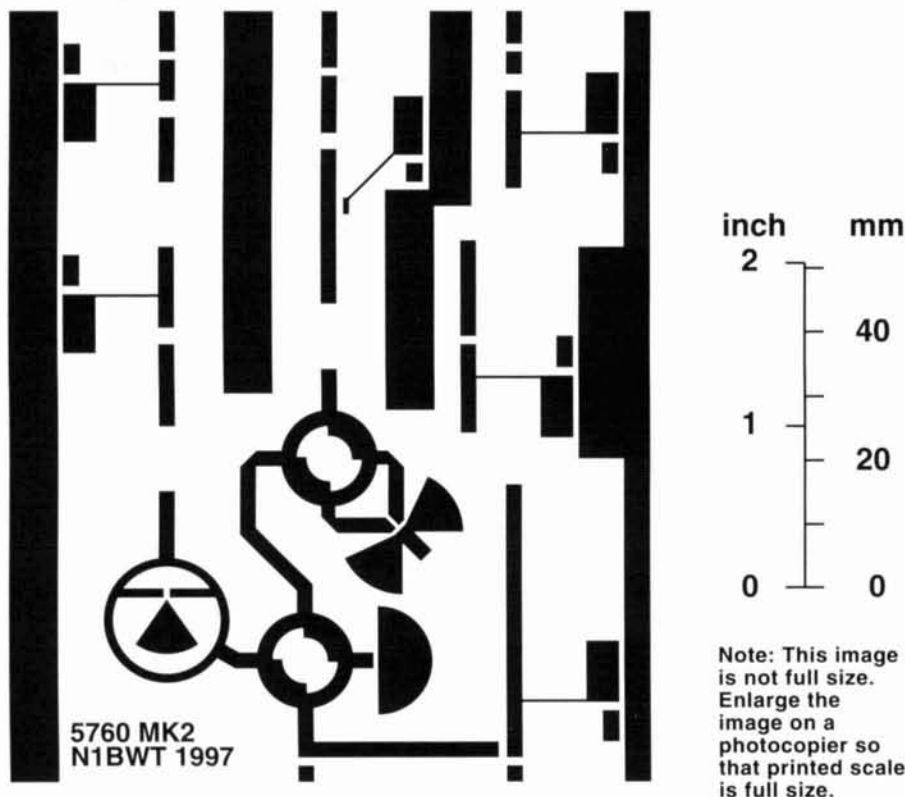

Figure 4. Printed circuit board layout for 5760 MHz single board transverter

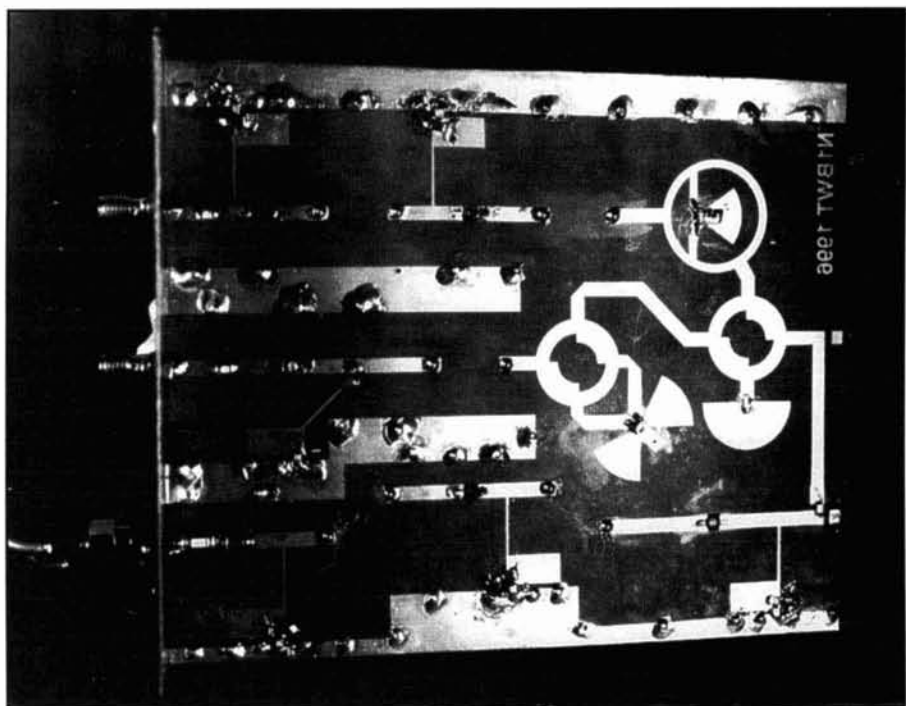

Figure 5—The top surface of a completed board. The parts on this side are very small compared to the board traces.

proper microwave ground. Aluminum does not solder well, so I cut out a brass endplate to match the aluminum ones supplied with the enclosure, drill holes for the connectors and solder the ground plane of the board (top and bottom) to the brass plate. The connector mounting screws only provide mechanical strength. Connector J1 need not be brought outside the box; I only did so for convenient testing.

Once the heavy soldering is complete, the other components may be installed, starting with the MMICs. On my hand-made boards, there are no plated-through holes, so I ensure short connections for the ground leads by mounting the MMICs on the bottom (ground plane) side of the board and bending the input and output leads up through the board to reach the printed transmission lines. It takes a bit of trimming at each hole (with a hobby knife) for lead clearance, but the sides of the holes should fit tightly to keep the ground contact as close as possible. Alternatively, Down East Microwave sells boards with plated-through grounding holes, so all devices can be mounted on top of the board with short lead length.

Bias resistors and decoupling capacitors are also soldered on top of the board, but the dc connections are brought out through small clearance holes so that the dc wiring is on the far side of the ground plane and does not cause unwanted feedback. Resistor values shown in the schematic diagram, Figure 1, are for operation from a 9 V source, provided from a three-terminal voltage-regulator IC. The IC should maintain a stable voltage for the transverter and LO board—even with a partially discharged 12 V battery—to keep frequency and power output stable.

Next, solder the dc blocking capacitors (in series with the transmission lines) in place. The capacitor connecting the LO to the mixers, C5, is initially connected to the test point for tune-up, rather than to the mixers. Then the probe pins are inserted into filter FL1 only. FL2 is bypassed by soldering short pieces of enameled wire to each of the transmission-line ends connecting to FL2, with the two wires parallel and closely coupled to form a small capacitor. Now we are ready to begin tune-up; the other filters will be added and tuned one at a time.

Tune-up

The tune-up procedure will tune one filter at a time, adding additional sections of the circuit sequentially. Since

the filters are separated by amplifier stages, interaction between them is minimal and repeaking previous adjustments is unnecessary.

The LO section is tuned first. An SMA connector is temporarily attached to the LO test point so that we can monitor output power here. I tune the transverters using only a power meter, and check the LO frequency with a surplus wavemeter. If you do not have a power meter, a diode detector is usable. Figure 7 shows one that can be quickly assembled “dead-bug” style on the flange of an SMA connector using a mixer diode pair and chip components—the values aren’t critical. Figure 8 is a plot of the detector sensitivity I measured using a Simpson 260 analog VOM; analog meters make tuning much easier. The plot shows that the expected power levels should provide reasonable output voltage, but shouldn’t be taken as a calibration curve, since sensitivity may change with frequency, temperature and different components.

Now install the tuning screw into filter FL1. I use 3/4 inch long flathead

brass screws rather than the round-head screws shown in Figure 6. When tuned to 5616 MHz, the head extends 0.29 inches above the top of the pipe cap. If you begin with the screw at approximately this setting, tuning should go smoothly. (Note: A 3/4 inch flathead screw has an overall length of 3/4 inch, while a roundhead screw measures 3/4 inch to the bottom of the head. So a round head screw could be used for tuning by measuring the extension to the bottom of the head. However, in the enclosure I used, the extra height of the screw head prevented the cover from fitting properly. A 5/8-inch-long screw would also solve this problem, but was not available at the local hardware store where I found the flathead screws.)

Next the LO source board at 561.6 MHz is connected to J1, and power is applied to the source and to IC1, IC2 and IC3. (If you can measure power, the LO power input to J1 should be +6 to +10 dBm.) Look for output power at the test point while adjusting FL1; there should be a peak within about a half-turn of the screw

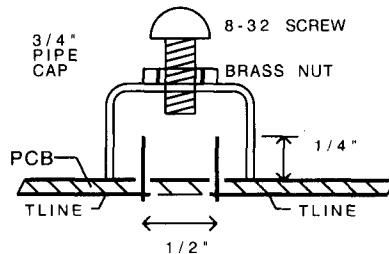
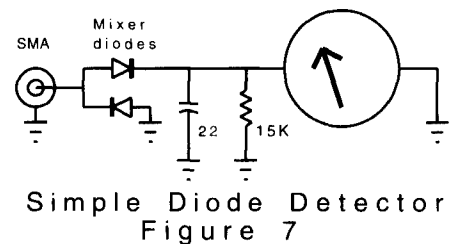
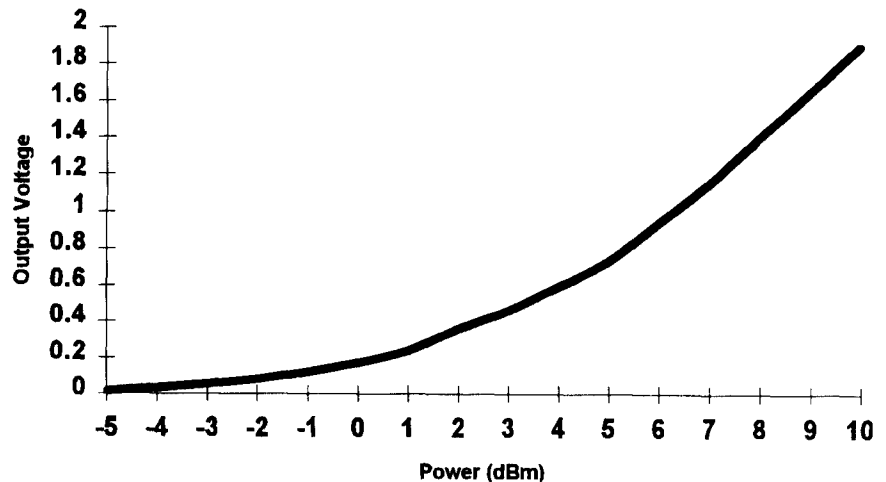

Figure 6. Pipecap Filter for 5760 MHz



Simple Diode Detector Figure 7

Figure 8. Simple Diode Detector at 5760 MHz



from the initial setting. If much more tuning is required, it's possible that you have found the wrong harmonic. If you have any way of measuring frequency, check it now.

Once you are confident that filter FL1 is tuned to the correct harmonic for 5616 MHz output, peak the output and tighten the locknut on the tuning screw. Then proceed to filter FL2: Remove the bypass wires, insert and solder the probe pins and adjust the tuning screw to the same depth as FL1. Apply power again, peak the tuning screw of FL2, and tighten the locknut. If you are able to measure power, the output at the test point should be +5 to +10 dBm. If the power is slightly low, trimming excess metal from the ends of the transmission lines around the filter probe pins will help.

Now that the local oscillator is complete, the transmitter is next. Move blocking capacitor C5 to the transmission line connecting to the mixers and remove the temporary SMA connector from the LO test point. Insert probe pins into FL4, and bypass FL5 with a wire capacitor just as FL2 was earlier. Initially insert the tuning screw into FL4 the same depth as FL1. Move the output power indicator to J3, then apply power to IC5, IC6 and the whole LO chain. Turn the FL4 tuning screw counterclockwise, decreasing the screw depth to raise the frequency. You should find a peak within about one-half turn of the screw, since filter FL4 should be tuned 144 MHz higher than FL1. Peak the tuning and tighten the locknut.

Proceeding to FL5, remove the bypass wires, insert and solder the probe pins. Set the tuning screw to the same depth as FL4. Apply power again, peak the tuning screw and tighten the locknut. The transmitter is now complete, with a typical output power of +10 dBm.

The final step is to tune the receiver section. Insert and solder the probe pins in FL3, and apply power to the LO chain and to IC4 through the 3-terminal regulator, IC8 (Figure 11; IC8 and surrounding components are attached to the back of the board, dead-bug style). Peak FL3, while listening to another station or to a weak signal source,¹¹ and tighten the locknut. If you can measure noise figure, adjust the voltage to IC4 for best noise figure by varying the 910 Ω resistor attached to IC8. Otherwise, leave the voltage at approximately 6 V, since the voltage for best noise figure is between 5 and 7 V and not very critical.

Performance

As a barefoot transverter, this unit makes an excellent rover rig, with about 10 mW transmitter output and about 3.5 dB receiver noise figure.

Both the LO and the transmitter outputs are pretty clean due to the double filtering. Figure 9 is a plot of the IF chain selectivity (when operated as a straight-through amplifier rather than a frequency multiplier). All LO

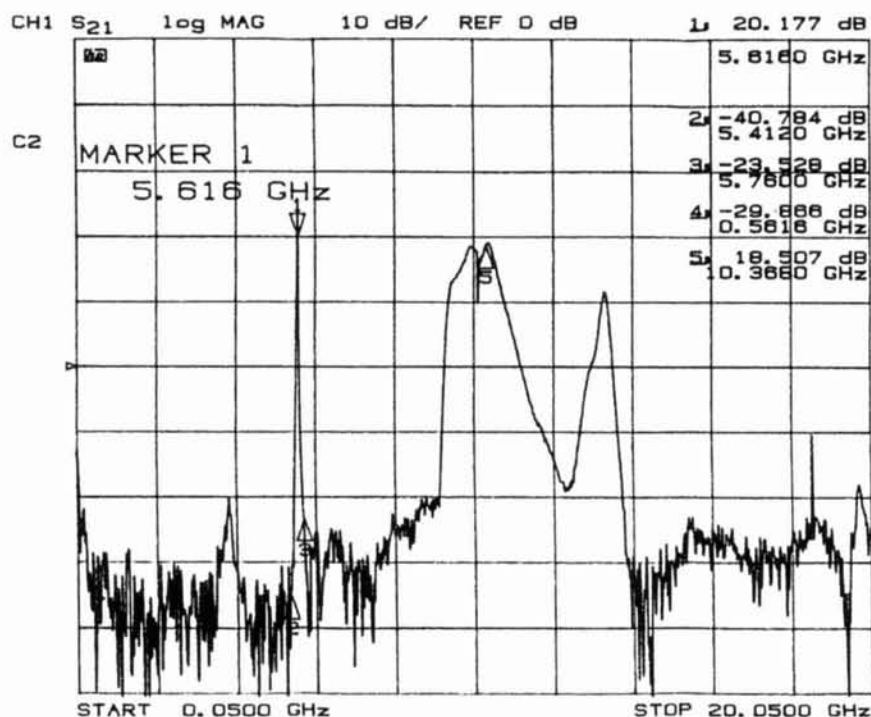

Figure 9—A plot of the IF chain selectivity (see text).

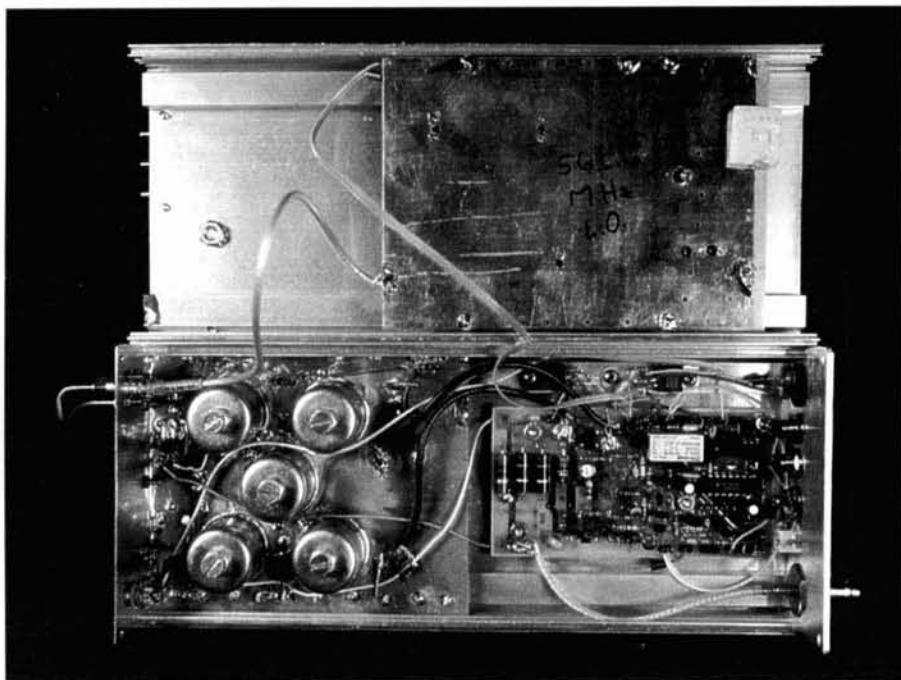

Figure 10—A transverter board packaged as a rover system.

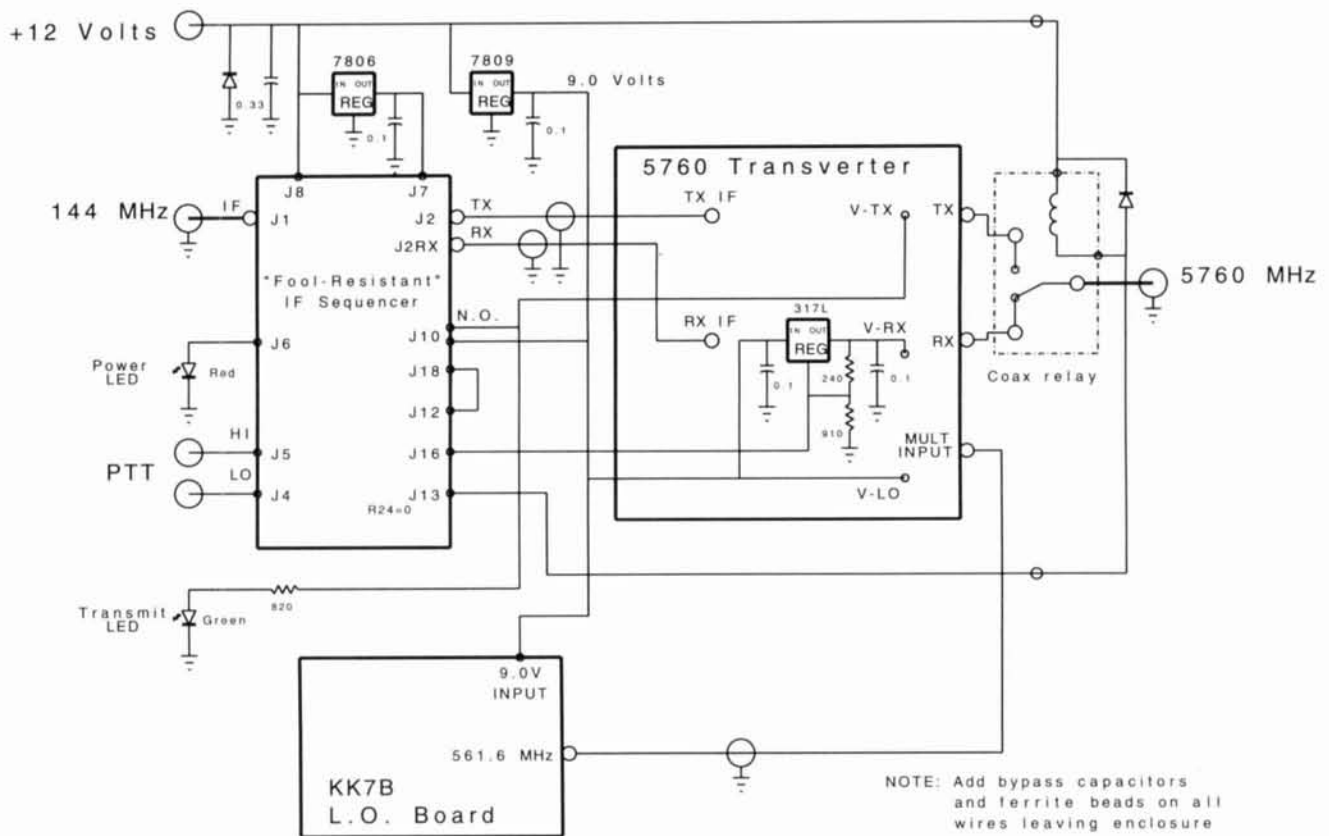

Figure 11. 5760MHz Transverter System Diagram

outputs at the test point are more than 60 dB down, except for the third harmonic of the LO sources at 1684.8 MHz, which is only 50 dB down. The transmitter output has some LO leakage, about 35 dB down from peak carrier output, and the image signal is about 45 dB down. Since the LO leakage is about 45 dB down when the transmit section is not powered, more shielding would be required for significant improvement. All other outputs are more than 60 dB down, except the second harmonic, which is only 30 dB down; as Figure 9 shows, the pipe-cap filters have little rejection above 10 GHz.

On the receive side, a single filter provides adequate image rejection to maintain a good noise figure.¹²

This performance is probably superior to lower-frequency "no-tune" transverters and should be an excellent foundation for a high-performance system, with the addition of power amplifiers and a low-noise preamp.

System

The transverter board does the RF work, but does not make a complete system without help. Figure 10 is a photograph of a transverter board packaged as a compact rover system in a Rose extruded box. One half of the extrusion contains the LO source board, mounted face down, while the other half contains the transverter board, also mounted face down, and an IF sequencer interface board.¹³ The two RF boards are mounted face down so that the active circuitry is sandwiched between the PC board ground plane and the grounded wall of the case, thus maximizing isolation between different sections. The block diagram of this basic system is shown in Figure 11. The minimal rover system in Figure 12 uses the RF-sensing function of the IF board to operate with only a simple HT and a horn antenna.

Unless you are willing to move the

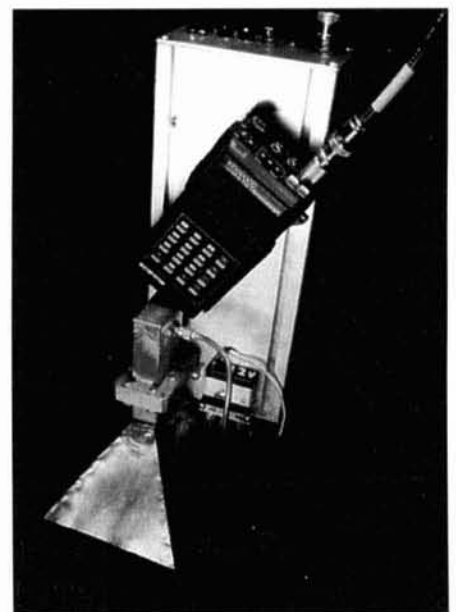
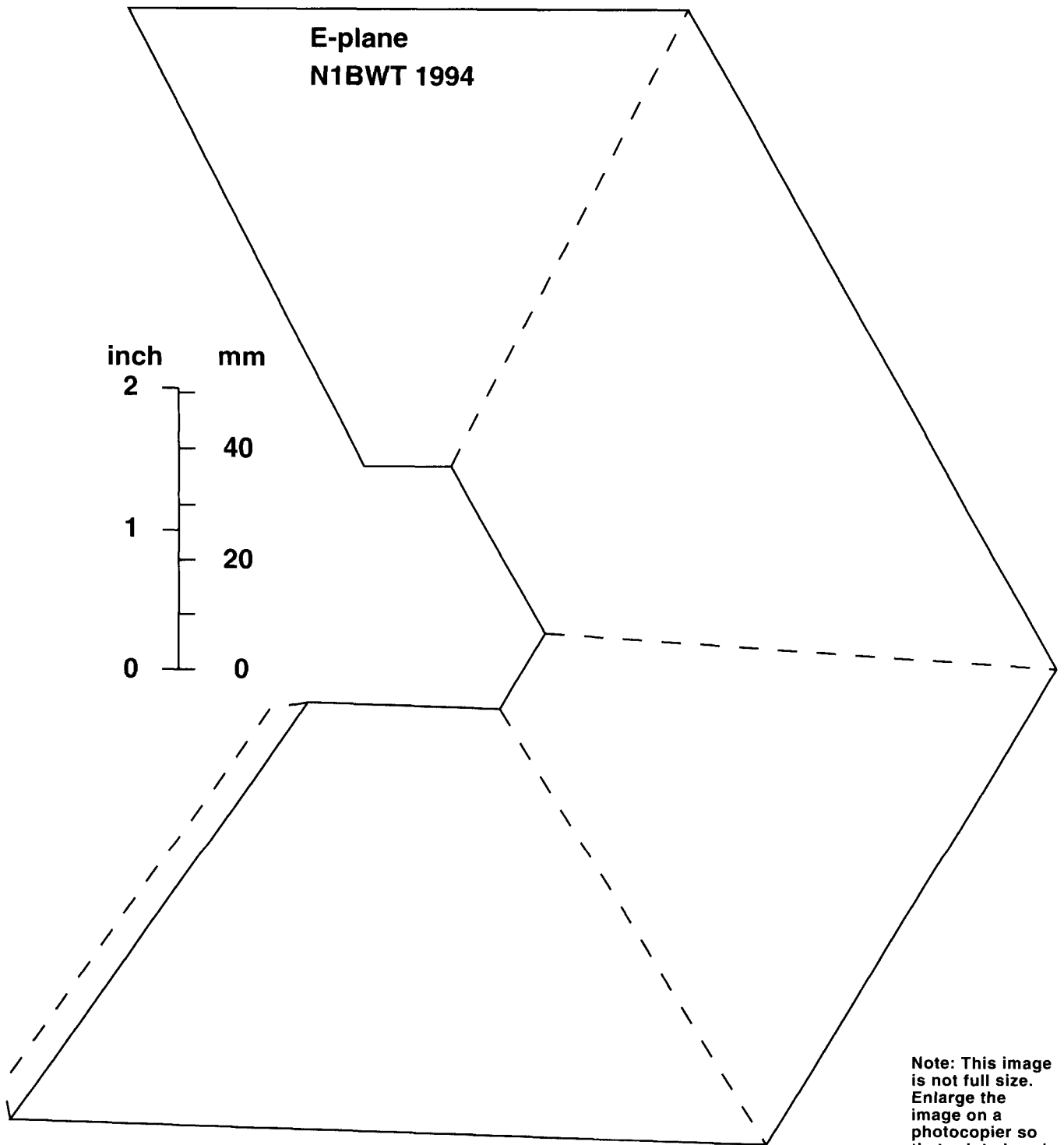

Figure 12—A minimal rover system. The RF-sensing function of the IF board allows operation with only a simple HT and a horn antenna.

Continued on page 11.

Template for 14.88 dBi horn for 5760 MHz



**Figure 13. 15 dBi Horn Template for 5760 MHz
(WR-137 Waveguide)**

Note: This image is not full size. Enlarge the image on a photocopier so that printed scale is full size. Alternatively, make a new full-size template with HDLANT (see Note 15).

antenna cable to switch from transmit to receive or to use separate antennas, an antenna switch is required. Down

East Microwave stocks some affordable used SMA coax relays that require 24 V to operate. I disassembled

one of these and rewound the coil (see the sidebar "Rewinding Coax Relays for 12 V Operation") to operate at 12 V,

Template for 11.48 dBi horn for 5760 MHz

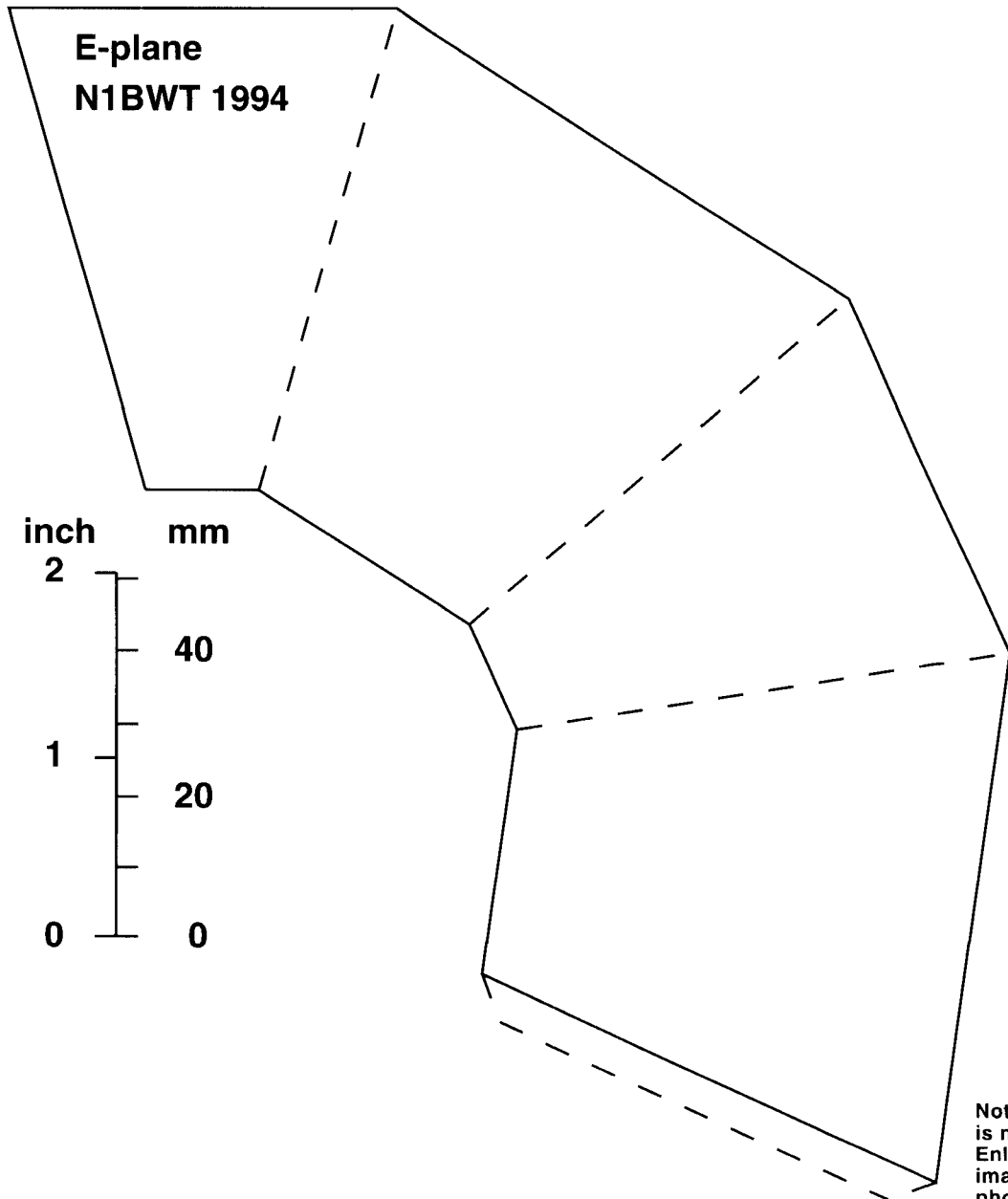

Note: This image is not full size. Enlarge the image on a photocopier so that printed scale is full size. Alternatively, make a new full-size template with HDLANT (see Note 15).

Figure 14. Feedhorn Template for RCA DSS Offset Dish
5760 MHz, WR-137 Waveguide
Phase center is about 7 mm. inside horn

Rewinding Coax Relays for 12 V Operation

Microwave operation from high places requires portable operation for most of us. The most convenient power source is usually the 12 V battery in the vehicle that gets us there, and modern solid-state devices work fine at 12 V, or less. Most surplus coax relays, however, are designed for operation at 28 V or more and don't switch reliably at 12 V. When available, 12 V coax relays are exorbitantly priced; so it would be nice if the higher-voltage relays could be converted. Since relays are ancient technology, digging through some ancient issues of *QST* yielded an article* that detailed the calculations necessary to rewind relays for different voltages. I will summarize them here because the back issue is probably no longer available.

Ham folklore says it is only necessary to remove turns from the coil until it works at 12 V. I'm told this often works for 28 V relays, but let's go through the numbers and see how well.

Calculations

The relative force generated by the coil to close a relay is conveniently measured in ampere-turns, simply the current through the coil times the number of turns. If we are rewinding a relay, rather than count thousands of turns we can simply fill the bobbin with wire and assume that the volume of wire is constant.

Using this assumption and standard US wire gauge (AWG) sizes simplifies the equations. The AWG wire diameters decrease geometrically with increasing AWG number, so that each size is approximately 1.12 times (or $10^{0.05}$) smaller than the preceding size. Using this relationship, we can calculate the number of turns per square inch, N , of bobbin cross section changing by a factor of $10^{0.1}$, or 1.26, per wire size, and the resistance, R , per cubic inch of winding changing by a factor of $10^{0.2}$, or 1.59, per wire size.

Since we are rewinding the same bobbin, area and volume are constant (k), so

$$N^2/R = k$$

Multiplying by I^2 / I^2 , this becomes:

$$(NI)^2 / I^2R = k$$

we can recognize NI as ampere-turns and I^2R as watts, or power.

This means that—for any wire size that fills the bobbin—the same amount of power applied provides the same number of ampere-turns, so what we need to calculate is the wire size that will draw the same power at the desired voltage:

$$V_1^2 / R = V_2^2 / R$$

If V_1 is the original, higher, voltage and V_2 is 12 V, then we must increase the wire diameter by:

$$\text{number of wire sizes} = 10 \log(V_1 / V_2)$$

Remember that a larger diameter wire has a smaller AWG number. The original article had a graph, but this is easily solved on a calculator, which they didn't have in 1956. I've summarized the most common voltages in the following table:

Common Relay Voltages

Original	Desired	# of wire sizes
28 V	12 V	4
48 V	12 V	6
115 V	12 V	10

Procedure

The rewinding procedure is straightforward: Peel the old wire off the bobbin, measure the wire size and rewind it with larger magnet wire as calculated above. Radio Shack

carries several sizes of magnet wire, which may include the one you need. Mechanical details should be pretty much like the original relay; take notes during disassembly. The most difficult part is often prying the bobbin off the metal pole. Relays in sealed cans are a larger problem, and I welcome suggestions. (Letters to the Editor?—Ed.)

The fastest way to wind the new coil is to wrap masking tape around a dowel or pencil until the bobbin fits snugly over it, chuck the pencil in a variable speed drill or lathe, and run it *slowly* to wind the wire on. At *low* speeds, it's safe to guide the wire with your fingers.

Example

I found several excellent coax relays with N-connectors at a hamfest, quite cheap because they required 48 V. They were wound with #38 AWG wire. From the equation above, converting from 48 to 12 V requires wire roughly six gauges larger, so I rewound one with #32 AWG wire. The original winding required 48 V at 54 mA, pulled in at 35 V and released at 15 V. After rewinding, it draws 265 mA at 12 V, pulls in at 8.5 V, and releases around 2 V. The power is slightly higher now, because six wire sizes is an approximation, but I can be sure it will still operate on a low battery. My 903 MHz station now runs entirely on 12 V.

The SMA relay in Figure 11 (from *Down East Microwave*) was an easy one to rewind. The cover is held on with two screws, and the bobbin is easily removable. The 28 V coil is wound with pretty fine wire—I measured the diameter, guessed the enamel thickness, and estimated the wire size as #42 AWG. From the table above, the new wire should be four wire sizes larger, or #38 AWG. I rewound the coil with #38, reassembled it and tested it. The relay now switches solidly at 11 V. A better choice might be #36 AWG wire, which would give a little more voltage margin for low-battery operation, but I don't have any in the junk box. Incidentally, this relay has an unusual construction that will not operate with the coil voltage reversed, so try it both ways to find the right polarity.

Alternative

As mentioned previously, we could have just removed turns to increase the current until the relay draws the same power at the lower voltage. If we take off half the turns, the resistance drops in half. The original resistance of the 48 V relay is $48 \text{ V} / 54 \text{ mA} = 888 \Omega$. At 12 V, we need 216 mA for the same power, or a new resistance of 55Ω , so we need one-sixteenth as many turns. We increased the current four times, so we end up with one-quarter as many ampere-turns as the original, or only one quarter as much force pulling in the relay. If we weaken the spring enough, it may work, but will it be reliable?

A few more trials convinced me that no matter how many turns of the original wire are removed from a 48 V relay, the force pulling it in at 12 V will only be 25% of that at 48 V. A 28 V relay isn't as bad—the force is only reduced by 12/28, to a bit less than half the original force. There is probably a combination of turns and spring bending that will work pretty well, but if you've done enough disassembly to remove some turns, why not take the rest off and rewind it for 12 V?

International

I haven't tried any relays from other countries, but I wouldn't be surprised if they use other wire size systems. In the UK, they may still use SWG sizes, which differ from AWG, but the relative sizes are close enough so that in-

creasing the diameter by the number of sizes calculated above should work. So measure the wire, convert to the nearest AWG or SWG size, and go from there. I don't know what metric standard wire is available. (The Component Data chapter of the *ARRL Handbook* contains a "Copper Wire Specifications" table that lists AWG specifications with the nearest equivalent SWG.—Ed.)

Conclusion

Rewinding a surplus coax relay for 12 V operation requires only one simple calculation and perhaps an hour of work; why not try it rather than pay exorbitant prices or use inefficient dc-dc voltage converters?

* L. B. Stein, Jr, W1BIY, "Some Hints on Relay Operation," *QST*, Jun 1956, pp 21-25.

so the whole system in Figure 12 can be powered by an automobile battery.

The IF sequencer board also provides all the circuitry and sequencing needed to safely control external preamplifiers and power amplifiers for a high-performance system.

Antennas

Only a simple horn antenna¹⁴ is needed for a basic rover system; I used my HDLANT¹⁵ computer program (download from <http://www.arrl.org/qexfiles/>) to create the template in Figure 13. Use the template to build a horn that has 15 dBi gain—like the one in Figure 12—from a bit of flashing copper. Just tape a full-size copy of the template to a sheet of copper or brass, cut it out, fold on the dotted lines, and solder the metal horn together on the end of a piece of waveguide.

For a rover system with better performance, feed a small DSS dish¹⁶ with an offset feed horn¹⁷ (see template in Figure 14). This and a multimode transceiver—for CW and SSB capability—make up the excellent rover system shown in Figure 15. The system is mounted on top of a 10 GHz transmitter. With a quick-change feed mounting arrangement I have a two-band rover station sharing the same dish. Of course, larger dishes can provide even better performance.¹⁸

Both of the antenna templates are for horns that mate with WR-137 waveguide (1.37" × 0.62" internal dimensions), but the larger WR-162 and WR-187 sizes also work fine at 5760 MHz. Surplus waveguide is available, so you should be able to find one of the three sizes or make a reasonable imitation from copper or brass sheet. Waveguide-to-coax transitions are more difficult to find, but easy to build: Figure 16 shows dimensions for a WR-137 transition. The coax probe is a section of 5/32" diameter brass rod with a hole drilled in it to fit over an SMA connector pin, which is soldered

in position. Trim the SMA's Teflon insulation flush with the inside of the waveguide. This unit has a low SWR from 5.2 to 7.5 GHz and outperforms several commercial units I have tested. If yours needs adjustment, vary the length of exposed SMA pin (nominal 0.110 inches) by moving the 5/32" diameter section and resoldering it at the new location; repeat until good SWR is achieved.

Potential

Even the basic rover system in Figure 12 is capable of communications over any line-of-sight terrestrial path. I can make this claim because we have frequently demonstrated that a simple 10 GHz WBFM Gunnplexer system is capable of distances more than 100 km. This simple 5760 MHz system using NBFM has comparable power output and antenna aperture, but has a 13 dB advantage in receive bandwidth (approximately 10 kHz vs 200 kHz) and a noise figure at least 5 dB better. The improvement of 18 dB translates—using the inverse-square law—to eight times better range capability (more than 800 km) enough for

all line-of-sight paths.

The improved rover system shown in Figure 15 adds another 10 dB of antenna gain and 5 dB better receiver bandwidth (even more for CW) to

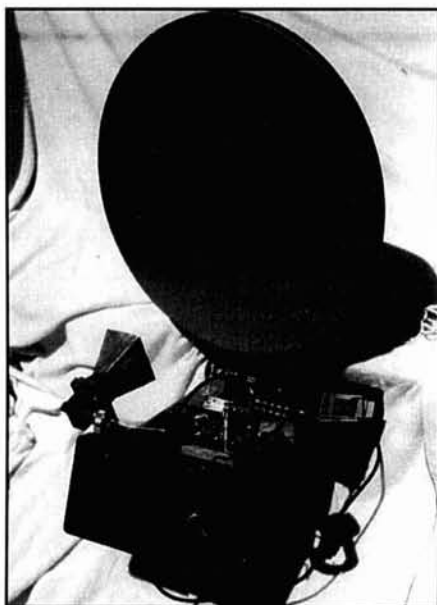
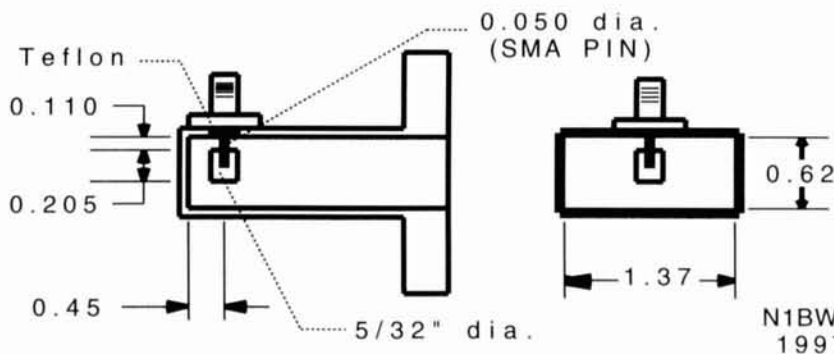

Figure 15—A two-band roving station that uses the 5760 MHz transverter.



WR-137 Waveguide Transition
Figure 16

provide the potential for over-the-horizon or partially obstructed paths.

From there, we can move up to larger antennas, a receive preamplifier and transmit power amplifiers—all the way up to EME capability.

Phase 3D

The Phase 3D satellite requires only a transmit capability at 5668 MHz. If there is another interested station not too far away, however, receive capability makes it possible to check out both systems before tackling the complexities of satellite tracking.

Published estimates¹⁹ of Phase 3D path loss at this frequency are 181.5 dB at perigee and 201.4 dB at apogee. With the estimated 22 dBic satellite antenna gain, the system in Figure 14 should be able to provide an uplink signal that is weak at perigee, and lost in the noise at apogee. One solution would be a larger dish, but that would have a beamwidth narrower than the manageable 8° beamwidth of the DSS dish. A better solution would be a modest power amplifier; perhaps I can put one together before the satellite is launched.

Conclusion

This transverter provides the compact convenience of a single-board unit without compromising performance. While it is not a "no-tune" design, tune-up is straightforward and systematic. Now it is possible to get on 5760 MHz without any hard-to-find surplus components.

Notes

- ¹R. Campbell, KK7B, "A Single-Board Bilateral 5760-MHz Transverter," *QST*, Oct 1990, pp 27-31.
- ²K. Britain, WA5VJB, "Cheap Microwave Filters," *Proceedings of Microwave Update '88* (Newington: ARRL, 1988) pp 159-163. Also appears in *ARRL UHF/Microwave Project Book* (Newington: ARRL, 1992) pp 6-6 to 6-7.
- ³P. C. Wade, N1BWT, "A Dual Mixer for 5760 MHz with Filter and Amplifier," *QEX*, Aug 1995, pp 9-13.
- ⁴R. Campbell, KK7B, "A Clean, Low-Cost Microwave Oscillator," *QST*, Jul 1989, p 15. Also appears in *ARRL UHF/Microwave Project Book*, pp 5-1 to 5-9.
- ⁵Mini-Circuits Labs, PO Box 350166, Brooklyn, NY 11235-0003; tel 718-934-4500; <http://www.minicircuits.com/>.
- ⁶D. Nelson, N0UGH, "MMIC Multiplier for 10.8 GHz Local Oscillator," *Feedpoint* (North Texas Microwave Society), March/April 1996.
- ⁷J. Davey, WA8NLC, "Frequency Multipliers Using Silicon MMICs," *ARRL UHF/Microwave Project Book*, pp 5-13 to 5-15.
- ⁸*Comb Generator Simplifies Multiplier Design*, Application Note 983, Hewlett-Packard.

- ⁹Z. Lau, KH6CP/1 (now W1VT), "3456 MHz Transverter," *QEX*, Sep 1996, pp14-20.
- ¹⁰Down East Microwave Inc, 954 Rte 519, Frenchtown, NJ 08825; tel 908-996-3584; <http://www.downtownmicrowave.com/index.html>
- ¹¹P. C. Wade, N1BWT, "Weak Signal Sources for the Microwave Bands," *ARRL UHF/Microwave Project Book*, pp 5-16 to 5-18.
- ¹²P. C. Wade, N1BWT, "Noise Measurement and Generation," *QEX*, Nov 1996, pp 3-12.
- ¹³P. C. Wade, N1BWT, "A 'Fool-Resistant' Sequenced Controller and IF Switch for Microwave Transverters," *QEX*, May 1996, pp 14-22.
- ¹⁴P. C. Wade, N1BWT, "Practical Microwave

- Antennas, Part 1," *QEX*, Sep 1994, pp 3-11.
- ¹⁵P. C. Wade, N1BWT, "Practical Microwave Antennas, Part 2," *QEX*, Oct 1994, pp 13-22.
- ¹⁶MCM Electronics, 650 Congress Park Dr, Centerville, OH 45459; tel 800-543-4330.
- ¹⁷P. C. Wade, N1BWT, "More on Parabolic Dish Antennas," *QEX*, Dec 1995, pp14-22.
- ¹⁸P. C. Wade, N1BWT, "High-Performance Antennas for 5760 MHz," *QEX*, Jan 1995, pp 18-21.
- ¹⁹W. A. Tynan, W3XO, "Phase 3D, A New Era for Amateur Satellites," *Proceedings of the 30th Conference of the Central States VHF Society* (Newington: ARRL, 1996) pp 47-61. □

Feedback

All I can say about my August *QEX* article is "Oops!" (see "Synthesizing Vacuum Tubes," *QEX*, Aug 1997, pp 17-21). The callouts in Fig 3 for a 2N5462 (Q1) and in Fig 5 for a 2N3822 are in error, Q1 should be an MPF3822

in both places. In Figure 5, the drain and source leads are interchanged in the layout so the figure is in error. Nonetheless, the source and drain are functionally interchangeable in JFETs, so the layout in Fig 5 is misleading but operable. My apologies to eagle-eyed readers.—Parker R. Cope, W2GOM/7, 8040 E Tranquil Blvd, Prescott Valley, AZ 86314 □

AMIDON, INC.

Committed to Excellence Since 1963



Now on the World Wide Web!

Full Technical Specifications On Line

Visit <http://www.bytemark.com>

Ferrite Toroids · Powdered Iron Toroids · Ferrite Rods · Ferrite Beads · Ferrite Split Cores · BALUNs and UNUNs · BALUN and UNUN Kits · Transmission Line Transformers · Technical Specifications · Experimenter Kits · Specialized Designs · No Minimum Order

Authorized Amidon Distributor

Order toll free
800 679-3184

ByteMark
Corporation
7714 Trent Street
Orlando, Florida 32807
407 673-2083 BBS / Fax
407 679-3184 Voice

