

Tests Of New Active MW Antennas

Dallas Lankford, 11/22/2011

The Quoddy Head 2011 DXpedition (at Quoddy House, the Eastern most privately owned house in the continental USA, on Quoddy Head, near Lubec, Maine) was not primarily a DXpedition. It was a test of new antennas which I invented and have been developing for the better part of 2011. Schematics and diagrams of some of the new MW antennas are at the end of this article. The results of these tests have shown that the new dual arrays are superior to 1000 foot terminated beverage antennas for MW DXing and that the quad arrays are more superior to 1000 foot terminated beverage antennas for MW DXing. The receiver was a Perseus, the laptop was a Lenovo W520 with I7 quad core with multiple 2nd HD's via plug-in caddies resembling CD drives, and a separately grounded common mode choke was used at the antenna input of Perseus. Nevertheless, before TA signal levels rose to sufficiently high levels, noise was experienced from the W520 switching power supply unless the W520 was operated on battery power. Next time I will bring spare batteries and more common mode chokes.

Originally the primary purpose of the 2011 Quoddy Head DXpedition was to test a dual active delta flag array (DADFA), a (non-variable) phased dual delta flag array with high performance FET followers attached directly to the antenna elements (no antenna transformers). The DADFA was erected pointing 60 degrees azimuth with the "null end" pointed at Quoddy House (the Eastern most, privately owned house in the continental USA, where the Perseus receiver was located) and with the "null end" of the DADFA about 30 feet away from Quoddy House. Comparisons were made with a terminated 1000 foot long BOG (T 1Kft BOG) also pointing 60 degrees azimuth with starting point about 200 feet away from Quoddy House, and the BOG also 200 feet or more away from the DADFA.

Nov. 4, 2011 early afternoon: The first TA carrier this afternoon was 1521 Saudi Arabia about 1650 UCT. No audio, just barely visible on the Perseus display. First audio was around 1730, but you could only tell that someone was talking. The language was identifiable occasionally about 1800, so I started comparisons of the T 1Kft BOG and DADFA at 1800. I hate to admit it, but the T 1Kft BOG won. What little audio there was, was clearer on the T 1Kft BOG than on the DADFA. But the DADFA was not the only new antenna being tested. About 1830 UCT I went outside and converted the DADFA to a dual active grounded delta flag array (equivalent to a dual delta EWE array, and which I will call a DAgDFA) which has 6 dB more signal output than the DADFA. I also added a 13.6 dB gain push-pull Norton transformer feedback amplifier. Tests resumed with this arrangement shortly after 1830 UCT and for a short period of time the competition was neck and neck..... But as the afternoon deepened, and TA signal strengths continued to increase, the higher signal output of the DAgDFA became unnecessary, so I went back outside and ungrounded the antenna elements (grounded delta flags are EWE's, and dual EWE arrays have poorer splatter reduction than dual flag arrays).

After about 1930 UCT the comparison of the DADFA and T 1Kft BOG continued. During this "sunset transition" as I call it, there was little difference in performance between the DADFA and T 1Kft BOG because during sunset transition the nulls of single antennas (beverages, flags, EWE's, etc.) and antenna arrays are degraded (for reasons that none of us understand clearly). It is only after sunset, usually an hour or so after sunset, that the patterns of directional MW antennas stabilize to their best patterns. After sunset transition was complete, the DADFA was superior to the T 1Kft BOG on about 85% of TA signals because of the DADFA superior splatter reduction. In some cases the difference was dramatic; TA's were heard clearly (albeit with some splatter) on the DADFA, but were virtually inaudible on the T 1Kft BOG (due to much heavier splatter). For the remaining 15% they were about equal in splatter reduction. In no case did the T 1K BOG have better splatter reduction than the DADFA.

THE BOTTOM LINE

The DADFA, when grounding is used pre sunset (and occasionally later as I will explain below), is a better MW DX antenna at a good low noise coastal site than a T 1Kft BOG.

The DADFA is a beverage killer.

At places like Grayland where 700' BOG's are the longest feasible (unless you trespass on other property), a Grayland beverage would be a more distant 3rd. At Kongsfjord 1000' unterminated (grounds have not been successfully used at Kongsfjord because its ground is almost solid rock) beverages for listening to the USA would be a distant 4th.

There was one occasion at the bottom end of the MW band (about 531 to, say 600 kHz) well after sunset when the S/N ratio of some TA's was not quite as good on the DADFA as on the T 1K BOG. This may be due to the noise floor of the flag antennas (the thermal noise emitted by the 1K terminating resistors) becoming evident at the low end of the MW band

because when I went outside and grounded the DADFA array again, the S/N ratio difference had disappeared. It was not splatter that changed, but hiss. Since the hiss was slight, I see no reason to use grounded DADFA's after sundown because the hiss did not significantly affect intelligibility. However, this effect was not observed on subsequent nights, so it could have been propagation of IBOC or antenna pattern change which was responsible for these observations.

Want A Simple 200 Foot Long Antenna With Performance Equal To Or Better Than A 1000 Foot Long Terminated Beverage For MW DXing?

Shortly before departing Ruston for Quoddy Head I was studying theoretical properties of WOG (= short wire on ground) arrays using EZNEC 5 and I discovered that according to EZNEC a quad WOG array with 95 foot WOG elements had a null pattern almost as good as a QDFA. A passive quad 95' WOG array would obviously be insensitive, but what if the 95' elements were activated with FET followers? I tested a single 95' active WOG just before leaving Ruston, and its signal output was equal to the signal output of a full size active grounded delta flag element. As back-up, I had shipped a complete spare DADFA (including a 2nd pair of FET followers). I could have used the spare to implement a quad active delta flag array and embarrass the T 1Kft BOG even more, but why beat a dead horse?

These active WOG arrays might be called QA95A and DA95A, but since they will always be active arrays, I will call them Q95 and D95. EZNEC predicted that a D95 (dual 95' WOG array) would not have good splatter reduction, about equal to a T 1Kft BOG. But was the sensitivity of a D95 equal to or better than a T 1Kft BOG? So on the morning of 11-5 the T 1Kft BOG was removed, and a D95 was implemented pointed 60 degrees azimuth with 200 feet twin lead lead-ins. The spacing between centers of the WOG's was the standard 100 feet that I use for my small arrays, so the total length of the D95 was 195 feet. The null end of the D95 was about 100 feet from the power line feeder to Quoddy House. The D95 was somewhat further from the main power line than the T 1Kft BOG had been, maybe 200 feet. Testing of the D95 began about 1830 UCT. Some TA signals had already reached audibility, so comparison of the D95 and DA95A commenced immediately. By 1930 UCT when there were numerous TA's at good strength it was clear that the sensitivity of the D95 was equal to the sensitivity of a DA95A, so the D95 sensitivity equaled the sensitivity of a T 1Kft BOG. After sunset transition was completed, the splatter reduction of the D95 could be compared to the splatter reduction of the DADFA. As expected, the splatter reduction of the D95 was not as good as the splatter reduction of the DADFA. On the other hand, the splatter reduction of the D95 was about the same as a 1Kft BOG. So if you don't want to mess with masts and delta antenna elements with terminating resistors, a D95 may be the antenna for you.

+++++

The Q95 Has Much Better Splatter Reduction Than A 1000 Foot Terminated BOG

The Q95 (quad active 95' wire on ground (WOG) elements spaced 100 feet between centers) became active about 1830 UCT 11-6. The Q95 showed its right stuff immediately by having better S/N ratios on some weak middle East TA DX compared to the only other reasonable antenna I had left, a single passive (but amplifier at the receiver) flag antenna, which has splatter reduction about equal to a 1000' terminated BOG. As is well known, single larger than usual flag antennas called SuperLoops have been the antenna of choice at [PEI DXpeditions](#); no European beverages in 2009, and no beverages at all mentioned in 2010. Of course, there were frequencies where the Q95 produced clear audio, while the flag produced no audio, but not nearly as many as I expected. Except for requiring four FET followers, the Q95 is easy to set up (no masts required, and only 4 relatively short ground rods... I use 2 foot long pieces of half inch OD galvanized electrical conduit cut from longer pieces using a small hand held pipe cutter... when the galvanized surface begins to oxidize I throw them away and cut new ones). The only small antenna likely to be better than it is a quad active delta flag array.

The Phaser used for the Q95 was the same phaser that was used for the QDFA at Grayland before the isolating amplifier was added. I did not use an isolating amplifier because I had no way of knowing in advance if an isolating amplifier was needed or not for the Q95. It appears not. A loop antenna was made from the single passive flag antenna by jumping the terminating resistor. After low band TA signals rose to a sufficiently high level, many TA's were heard well on the single flag antenna, but much better on the Q95, and mostly not at all on the loop (the loop null was pointed NNW into Canada, and SSW into the Atlantic Ocean). Clearly the Q95 does not suffer from the same low band null loss that the QDFA suffered from at Grayland. Part of the reason may be that the twin lead from the phaser-combiner near the center of the Q95 array to Quoddy House as only 200 feet long, while the lead in from the phaser-combiner of the QDFA to the Grayland motel room (AKA DX central) was 300 feet long. In any case, the Q95 does not require an isolating amplifier, which makes it even simpler than the QDFA to put up and take down, if you don't count the complexity of the FET followers. The FET followers have more gain and less noise output than typical FET followers, so unless you can find someone to build them and adjust the 2nd order intercepts for you, you will have to build and adjust them yourself.

#####

QH 2011 Log, Update 11/16/2011

There were other stations heard at Quoddy Head 2011 which could be added to the list below, but QH 2011 was not primarily a DXpedition. It was a test of new antennas.

There are enough entries in the log now to conclude that the dual active delta flag antenna array is superior to 1000' terminated BOG's for MW DX and the quad 95' WOG array is even better.

- 531 Algeria, El Ain Beida, strong and clear, // 549, around 2100 UCT, 11-4
- 549 Algeria, Les Trembles, strong and clear, // 531, around 2100 UCT, 11-4
- 585 Tunisia, Gafsa, RTT, presumed, Arab singer accompanied by middle East music 2145 11-8
- 612 Morocco, Sebaâ-Aioun, sign on with national anthem 0500 11-7, followed by brief announcement, then Qur'an chanting
- 639 Czech Republic, Český rozhlas 2/6, various, sign off with anthem // 954 just after 2300 11-6
- 648 Spain, Granja Escuela (Badajoz), very clear, //585 0100 11-6, 648 was a difficult splatter covered frequency when I was at Quoddy Head in October 2008 using 750 foot and 1500 foot BOG's
- 657 Italy, various, underneath Spain RNE 5, // 1575 about 0300 11-8
- 666 Syria, Sabbura, presumed, not // Algeria 891, bits of middle East music, can't tell if the singer is a man or woman, 2009 11-6
- 675 The Netherlands, Lopik, R. Maria, religious programming, very clear around 2115 11-6, Arab talker underneath, the Q95 really kills splatter on this frequency and lets you hear underneath the dominant signal
- 675 Libya, Benghazi, Radio Jamahiriya, presumed, 2202 11-8
- 693 United Kingdom, various, BBC Radio 5 Live, EE talkers, every night
- 693 UNID Arab chanter 0052 11-6, not Algeria
- 702 Monaco, Le Col de la Madone, just after 2100 11-6 an ID in French believed to be China Radio International, arm chair listening audio quality on the Q95, much better than in October 2008 when I was at QH
- 702 Monaco, Le Col de la Madone, somewhat weak, but quite clear, as clear as it ever was in 2008... French announcer, French EZ listening songs with musical instruments accompaniment, around 2000 UCT, 11-3
- 711 France, Rennes-Thourie, France Info, there every night
- 747 The Netherlands, Zeewolde (Flevoland), presumed, good just before 0300 11-8, but faded at ToH
- 756 Germany, various, Deutschlandfunk, German talker, OK signal, 2224 UCT, 11-4
- 765 Iran, Chahbahar, chanting // 1503 about 0100 11-6
- 774 Egypt, Abis, Middle East Radio, presumed, 0040 11-6 under Spain with middle East singing
- 774 Egypt, Abis, Middle East Radio, presumed, noted in passing 11-2 about 2000 UCT
- 774 Egypt, Abis, Middle East Radio, chanting about 0230 11-5, // 819
- 783 UNID (haven't listened to recording yet) two, maybe three stations here, m FF talker and f FF talker, very clear at times, generally good, probably Algeria and Nouakchott, with perhaps a third female chanting in an african language, possibly Nigeria (Nigeria was also noted on 917, but with little or no audio)
- 819 Egypt, Batrah, presumed, noted in passing 11-2 about 2000 UCT
- 819 Egypt, Batrah, chanting about 0230 11-5, // 774
- 855 United Kingdom, Villa Farm (Ludlow), Sunshine Radio, // 1530, EZ listening rock, about 0058 11-9
- 882 United Kingdom, various, BBC Radio Wales, very strong around 1952 11-6
- 909 United Kingdom, various, BBC Live 5, very strong and clear, 2235 UCT 11-4

918 Slovenija, Ljubljana-Domzale, coo coo clock IS about 2130 11-6 followed by "Radio Slovenija" ID, and into American accented English news read by a woman; big het from Nigeria plus other weak signal(s) on frequency, a mess tonight on this frequency, the Q95 hears almost too well

945 France, Toulouse-Muret, France Info, male French talker about 2200 11-7

954 Czech Republic, Český rozhlas 2/6, various, various, sign off with anthem // 639 just after 2300 11-6

963 Tunisia, Tunis, presumed, chanting up to about 2200 11-7

972 Germany, Hamburg, NDR Info, presumed, two English EZ listening songs, German language announcers, but faded at 2100 11-7 so no ID

981 Algeria, Oulet Fayet, Alger Chaîne 1, presumed, Arabic singing with drums and string instrument(s), but not the usual middle East style, 0330 11-8

999 Moldova, Maiac, TWR IS about 2000 11-7

1008 The Netherlands, Zeewolde, GrootNieuwsradio, presumed, hymn-like music, Dutch announcer, about 2000 11-8

1035 UNID This frequency has severe splatter at Quoddy Head, and even though a station or stations were heard every night, sometimes very strong and clear, especially on the Q95 array, definitely IDing them has defeated me. The format(s) are sometimes music music, sometimes EZ listening rock with English language singers, sometimes music of a type I am not familiar with, occasionally in language(s) I am not familiar with (sometimes Russian), sometimes announcers (sometimes male, sometimes female, sometimes both alternating) talking for varying periods of time, with occasional what sounds like "hifi FM" or "hifi AM", and occasionally what sounds like the word "Estonia." Sometimes the announcer(s) gave song titles and singers names in English.

1053 United Kingdom, various, TalkSport, "TalkSport" ID about 2100 11-7, English speaking announcer talking about sports, het on about 1054 kHz

1062 Italy, various, // 1575, 2019 11-6, same echo from the synchros as when I was at Quoddy Head in October 2008, strong with fast male talker

1062 Iran, Kerman, presumed, unusual harmony chanting by two males, about 0100 11-6

1080 Iran, Abadan, presumed, singing chanter, about 2100 11-7

1089 United Kingdom, various, TalkSport, // 1053 English announcer talking about sports before and after 2100, about 2100 11-7

1107 United Kingdom, various, TalkSport, // 1053, distinctive jingle at ToH 2200 11-7

1116 Italy, various, //1575 about 2100 11-7, fast Italian talker and occasional distinctive tinkling sound

1116 Iran, Bandar Lengeh, presumed, chanter under Italy, about 2100 11-7

1134 Croatia, Rasinovac, Glas Hrvatske, there every night

1143 Kaliningrad, Bolshakovo, most likely the one, R. Mayak IS, 2130 11-6

1143 Kaliningrad, Bolshakovo, most likely the one, R. Mayak IS, 0330 11-8

1170 United Arab Emirates, Al Dhabbaya, Radio Sawa, clear, but with IBOC hiss 2021 11-7, male Arabic crooner

1179 Romania, various, România Actualitatea, IS played over and over again like a broken record around 2015 11-7 (this one not heard at QH in October 2008)

1188 Iran, R. Payam, 3 note IS about 2300 UCT 11-4

1188 Germany, Reichenbach, MDR-Info, presumed, male and female German talkers, after 0400 11-8

1206 France, Bordeaux-Nice, strong as usual every night, some fading, both high and low side carrier hets not noted when I was here at QH in October 2008

1215 United Kingdom, Absolute Radio, strong as usual every night, some fading, I seem to recall Spain surfaced here also

1224 Bulgaria, Vidin, R. Bulgaria IS 1900 11-6

1224 Iran, Abadan, weak under Bulgaria, 1900 11-6

1224 Iran, Abadan, chanter, 2035 11-8

1242 France, weak but clear about 1930 11-2

1251 Libya, Tripoli, presumed, Arab singer with middle East music 2003 11-6

1296 United Kingdom, Langley Mill (Birmingham), presumed, good with female Indian singer 2056 UCT 11-4

1296 Sudan, Reiba, presumed, Arabic Qur'an chanting, 0222 UCT 11-7

1296 Spain, various, COPE, 2059 UCT 11-4

1314 United Arab Emirates, Al Dhabbaya, "Radio Farda" (sounds like Radio Fardo) by female announcer, male (Farsi?) talkers before and after 2100 11-7

1323 Germany, Wachenbrunn, Voice of Russia, English programming, sign on with English announcement "This is the Voice of Russia world service" 0500 11-7

1323 Romania, Târgu Mureș, Romanian national anthem began with chimes at 1956 11-7 and continued until about 2000, under Germany all the way, but nevertheless rather clear because of the slow French talkers

1332 Czech Republic, Český rozhlas 2/6, Domamil, faded up at 0256:23 with national anthem already in progress, 11-8

1341 Northern Ireland, Lisnagarvey, ID preceded by FM frequency, "... 1341 medium wave, this is BBC Radio Ulster," classical music 2100 and later, some male and female English talkers

1377 France, excellent about 1930 11-2

1377 Armenia, Gavar, VoR IS (Pictures at an Exhibition) started about 2258:50 UCT 11-5 and was repeated

1386 Spain, Bilbao, Euskadi Irratia, // 1476, accordion music just before 2200, 11-2

1394.850 Albania, Fllakë, TWR IS 1918 and later 11-6 being repeated over and over like a broken record

1395 Armenia, Yerevan or Gavar (depending on which reference you consult), Radio Kavkaz/Golos Rossii, carrier appeared distinct from Albania 1394.850 considerably before 2130, talker which sounded Russian after Albania off about 2130, clear ID about 2230 11-4 on the dual active delta flag antenna array, not as much clear audio on the DADFA as on the Q95 array on 11-6, but the ID at 2230 is easily as good as the 2200 ID from the Q95 on 11-6. The 11-6 reception was spotted first on the 11-6 recording and I came back to the 11-4 recording after confirming the 11-6 reception with help from several kind people on the RealDX site. Don't you love Perseus? Programming was quite clear at times, though not as clear for as long periods of times as on the Q95 array.

1395 Armenia, Yerevan or Gavar (depending on which reference you consult), Radio Kavkaz/Golos Rossii, carrier appeared distinct from Albania 1394.850 considerably before 2130, talker which sounded Russian after Albania off about 2130, ID about 2200 11-6 which I could not make out and distinctive 5 musical notes at ToH which I could not match to any IS found on line, reappeared later about 0100 11-7, seemingly the same distinctive 5 musical notes, until 0200, perhaps later, quite clear around 0137, ID(?) 0143, "Radio ... Radio..." (the word "Radio" twice, I could not make out much of the rest). Thanks to Paul Logan, Dmitry Mezin, Mauno Ritola, and Bjarne Mjelde on RealDX for help with this entry. The 2200 ID is "Golos Rossii" and the consensus is that this is Armenia. The 0100 - 0200 logging is consistent with Armenia per data on the [asiawaves](http://asiawaves.com) site. Programming was quite clear at times. Outstanding DX from the Q95 antenna array.

1395 Armenia, Yerevan or Gavar (depending on which reference you consult), Radio Kavkaz/Golos Rossii, carrier appeared distinct from Albania 1394.850 considerably before 2130, talker which sounded Russian after Albania off about 2130, clear "Voice of Russia" ID in English followed by the distinctive 5 musical notes about 2330 11-7 on the dual active delta flag antenna array, not as much clear audio on the DADFA as on the Q95 array on 11-6, and the ID at 2330 not quite as good as the 2200 ID from the Q95 on 11-6, but good enough. Programming was quite clear at times, though not as clear for as long periods of times as on the Q95 array. Receptions of Armenia 1395 on two different nights of QH 2011 with the dual active delta flag array should convince most people that 1000' BOG's and beverages are not needed for state of the art MW DXing.

1395 UNID after 2200 when American country and western songs appeared, no announcer, continuing to at least 2237 11-7

1404 Romania, Vadu Izei, România Actualități/Radio Sighet, sign on with national anthem, about 2000 11-7

1422 Algeria, Alger, R. Coran, presumed, male musical chanter, 2158 11-6

1422 Algeria, Alger, sign on with national anthem about 0400 11-8, chanting before and after

1422 Germany, Heusweiler, classical music, and then "Deutschlandfunk" ID at 2200 11-6

1431 Djibouti, Arta, heard every night, albeit often with some splatter, "Sawa" ID about 2002 11-6, programming mainly singing in Arabic accompanied by middle East music, sounded pop to me, with occasional male and female Arabic talkers

1440 Luxembourg, Marnach, CRI in German, mostly strong and very clear, but occasionally faded to weak about 1930 11-2

1440 Luxembourg, Marnach, noted again in passing 11-4 in French and Chinese, quite strong and clear around 2140 UCT

1458 United Kingdom, Brookman's Park, Sunrise Radio presumed, more info and an ID on the 11-2 recording around 2011 UCT, more UK stations on this frequency tonight, or so it seems

1458 United Kingdom, Brookman's Park, "This is Sunrise Radio" ID about 2000 11-7, followed immediately by "Sunrise Radio..." jingle sung by female(s)

1458 United Kingdom, Ashton Moss (Manchester), Gold Manchester, "This is Gold" ID about 2337 11-7, EZ listening rock and phone-in talk. An interesting frequency.

1458 Gibraltar, Gibraltar, "Radio Gibraltar" ID about 0400 11-7 by male announcer, followed by female announcer, a very nice catch on the Q95 array

1467 France, Roumoules, Trans World Radio, Arabic progrm, around 2140 UCT 11-4

1467 Iran, Isfahan, chanting, surfaced through France around 2140 UCT 11-4

1467 Saudi Arabia, unknown location, // 1521, 2210 11-8

1476 Spain, Birbilondo, Euskadi Irratia, // 1386, accordion music just before 2200, 11-2

1503 Iran, Bushere, // 1512, 2316 UCT 11-4

1512 Iran, Ardabil, // 1503, 2316 UCT 11-4

1521 Saudi Arabia, Duba, very strong and clear about 1930 11-2

1521 Saudi Arabia, Duba, // 1467, 2210 11-8

1530 Vatican, good clear IS 2000 UCT 11-2

1530 Sao Tome e Principe, Pinheira, VOA IS being repeated at 0259 11-7 tune in with parts of the Romanian national anthem surfacing through the VOA IS on the new Q95 quad active WOG array

1530 Romania, Mahmudia, Radio Romania Cultural, presumed, Romanian national anthem already in progress at 0259 11-7, sung a cappella by male and female choir, the Q95 is really strutting its stuff

1530 Sao Tome e Principe, Pinheira, VOA IS repeated prior to 0300 11-8. All my 2011 receptions of them here in 2011 have all been clearer than any of October 2008 receptions previously at QH. Do you think that the reason might be that last time I used only beverages, and this time I am using a DADFA? After all, October 2008 was more or less in the middle of periods of hundreds of consecutive days of no sunspots.

1530 Romania, Mahmudia, Radio Romania Cultural, presumed, Romanian national anthem already in progress at 0259 11-8, sung a cappella by male and female choir, difficult... only bits and pieces of the NA made it through... but easily as clear as it was on the Q95 yesterday. There is another Romanian listed on this frequency. I do not recall why I decided this one is more likely. Perhaps someone more knowledgeable than me about this situation would venture their opinion?

1530 United Kingdom, Cothridge (Worcester), Sunshine Radio, // 855, EZ listening rock, about 0058 11-9

1548 Moldova, Grigoriopol, in the clear with TWR IS at 2000 11-8, Kuwait waaayyy underneath

1548 Kuwait, Kuwait City, "Radio Sawa" ID around 1915 UCT 11-4

1548 Moldova, TWR Romanian IS about 1915 UCT 11-4

1548 United Kingdom, "BBC Radio Bristol" ID after EZ listening mx about 1915 UCT 11-4. Yep, there was a lot of activity on this frequency around 1915 11-4

1557 France, strong, clear around 1930 11-2

followers basically transform the open source voltages of the flag elements directly to 50 ohm outputs. No antenna transformers are used, so there is no reduction of signal levels. This is equivalent to attaching 15 dB gain very low noise figure amplifiers directly to the flag elements. In other words, low signal level output flag antennas and flag arrays are converted to high signal level output flag antennas and flag arrays. Grounding the flag elements converts them into EWE elements with 6 dB additional signal output. Single EWE elements generally have poor patterns which are ground dependent. But dual EWE arrays have much better patterns and are more or less ground independent, just like dual flag arrays. Thus before sunset when greater gain is needed, the array can be operated as a dual EWE array, while near and after sunset the array can be changed to a flag array with superior splatter reduction. The reverse is done at sunrise.

Q95 Active Arrays

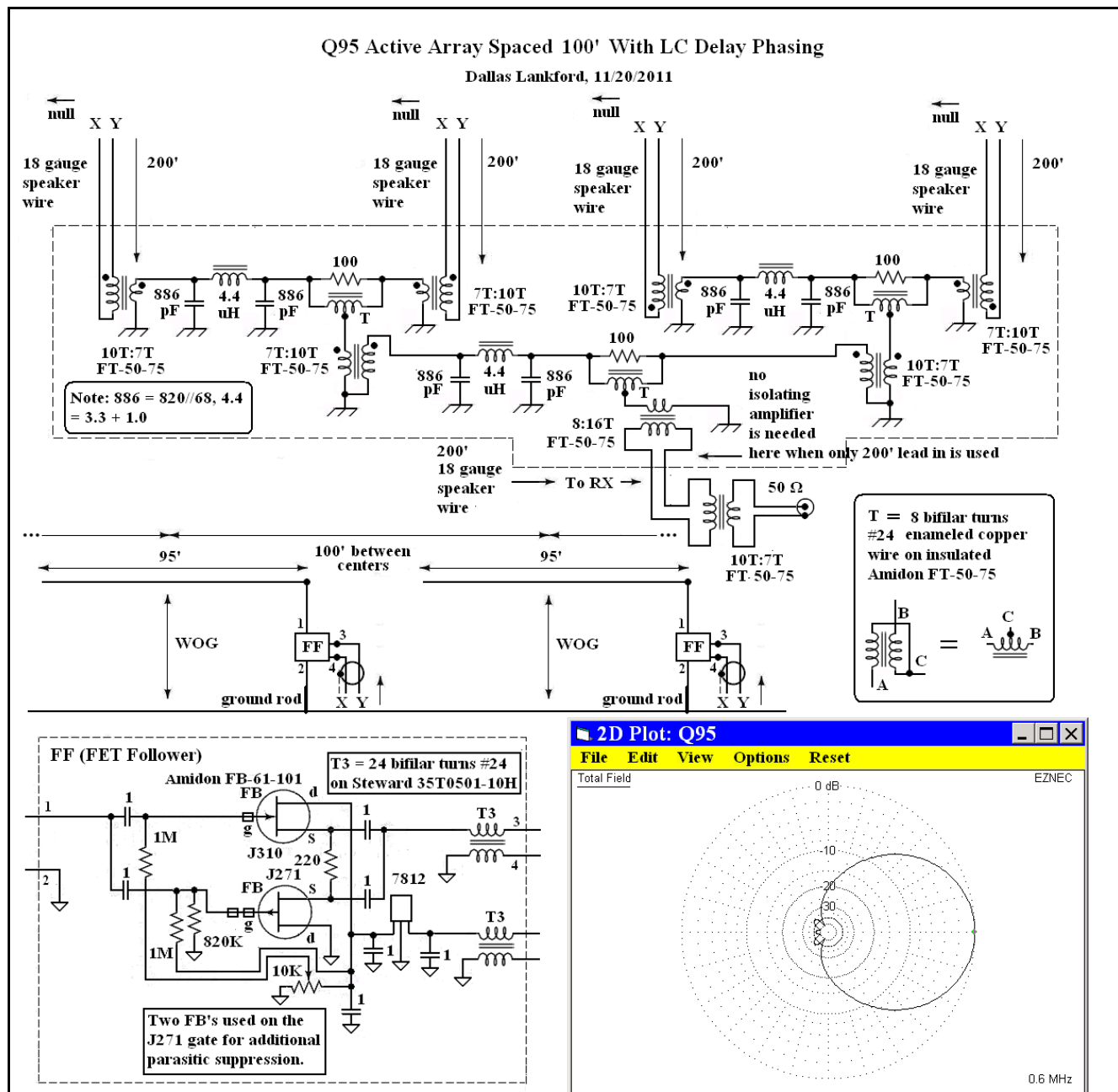

Isolating Amplifier

The quad delta flag array, which has been in use at several MW sites since April 2009, required an isolating amplifier to

eliminate loss of low band nulls when 300' of lead in was used from the phaser-combiner to the receiver. At Quoddy House the Q95 array was laid out (on a mowed pasture with thick grass 3 inches to 6 inches above the actual ground) about 100' to the North of the house with the center of the array close enough to the house so that 200' of shielded twinax was sufficient. With this arrangement there was no obvious degradation of the low band nulls, so no isolating amplifier is need when the Q95 is implement in this way.

Grounding The Far Ends

In the original schematic diagram at the beginning of this article, the far ends of the WOG's were grounded because EZNEC said that you got 3 dB more gain by doing that. However, tests here in North Louisiana showed that was not the case, so the WOG arrays at Quoddy Head did not have their far ends grounded. However, due to an oversight the schematic update was not made until after I returned from QH.

Regulator Noise

Originally all of the 3 pin 12 volt regulators were low dropout (LDO). But one type I used had a maximum input DC voltage rating of 17 volts, discovered only after two of the FET followers were mailed to QH, making it risky to use three 6 volt lantern batteries in series for DC power. Another LDO, made by Fairchild with higher input DC voltage rating, produced noise starting about 700 kHz and increasing amplitude as frequency decreased. The Fairchild LDO noise was not discovered until QH because of much higher man made noise in Ruston, LA. The noisy Fairchild LDO's were field changed to standard 7812's at QH after a 60 mile round trip to a Radio Shack at Machias, Maine.

Negative Impedances

In an earlier version of this article, before reading the source data of the EZNEC simulations, I discussed raising the Q95 antenna wires several feet above the ground, which would be a short beverage variation. However, placing the WOG elements of the Q95 on the ground is probably mandatory to get the pattern in the graphic above because according to the EZNEC source data, if the wires are raised more than a foot above the ground, then the real parts of some of the antenna output impedances become negative. Based on numerous tests and measurements that I have made in the past, the patterns of antenna arrays with negative impedances are invariably more or less non-existent. This is, for example, the case for all vertical arrays that I have tested. Why the Q95 when its antenna elements are within a few inches of the ground does not have negative real parts of some of its output impedances is a mystery to me because it may be regarded, after all, as a vertical antenna array with its vertical elements re-oriented horizontally and laid flat on the ground.