

Using Diodes for Fan Control.

by **Rob K** on July 28, 2008

Table of Contents

License: Attribution Non-commercial Share Alike (by-nc-sa)	2
Intro: Using Diodes for Fan Control.	2
step 1: Options For LEDs	3
step 2: Things you will need	4
step 3: Wires for leds (optional)	4
step 4: The Diodes	5
step 5: Hack the old fan plug for new fan controller power.	6
step 6: Attaching power to fan controller and ground.	7
step 7: Testing	8
Related Instructables	9
Advertisements	9
Comments	9

Intro: Using Diodes for Fan Control.

This is an alternative to using rheostats and chips for controlling fan speed.

The idea for this came from <http://www.cpemma.co.uk/sdiodes.html> and I wanted to explain it a little more and build a few of them. Basically a diode type 1N4001 drops around 0.75 volts with a typical fan. When you link them together then the voltage can be varied.

This is taken from the site

Using a chain of diodes mounted on a rotary switch, a series of voltage steps can be produced giving adequate control for fans.

This control method has several advantages;

- Cost is less than that of a half-decent rheostat, and much less than the price of a good one.
- number of fans wired in parallel (or to a fanbus) can be controlled from the unit without danger of overload. Cheap rotary switches will handle 1amp at low voltage, rheostats to handle such currents are big and expensive.
- The full 12V can be used if required. Basic semi-conductor voltage regulators lose about 2V and would need a by-passing switch to run the fans at full speed.
- The heat produced is spread over a number of diodes. Each one will only generate about a watt at the maximum 1amp load, and less than 0.1W per diode with a typical single fan.
- Unlike resistors, voltage drop is about the same at all fan currents, so fan start-up at low voltages is more assured and a wide range of fans can be used on the same unit.
- Last but not least, adding display lights to form a voltage bargraph or show switch position is easy.

This is my adaption to the original idea. I will use the pictures from the site to help explain.

I did one of the switches as a speed up video.

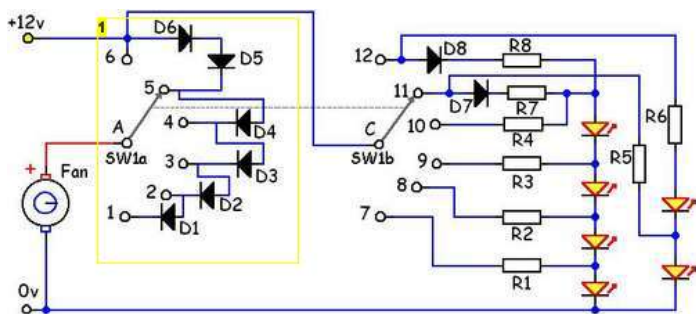

Image Notes

1. This is the basic idea for controlling fan speeds.

step 1: Options For LEDs

Their are several ways that LEDs can be used for this to show what setting the switch is on.

- Bar graph
- single Indicator
- No LEDs

The pictures help explain.

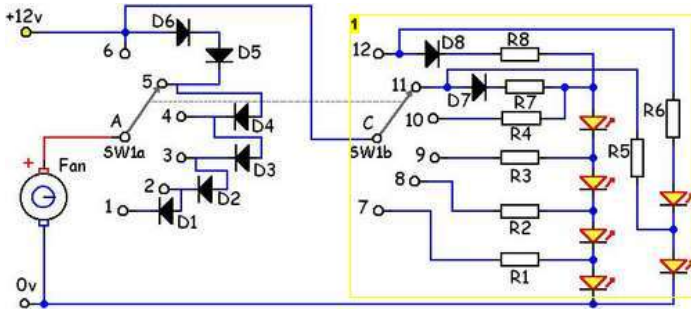

Image Notes

1. This is an option useful for a low power LED bargraph. The resistors have to be calculated for each strand since it is adding another led.

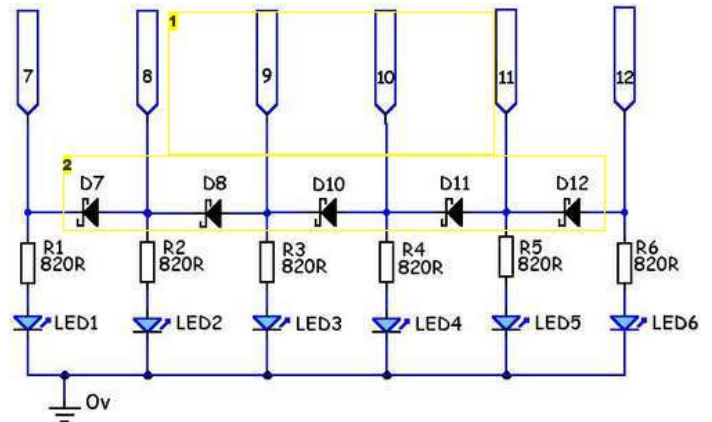

Image Notes

1. This option is better for doing a graph with high powered LEDs.
2. The diodes are 1N5817 Schottky diodes.

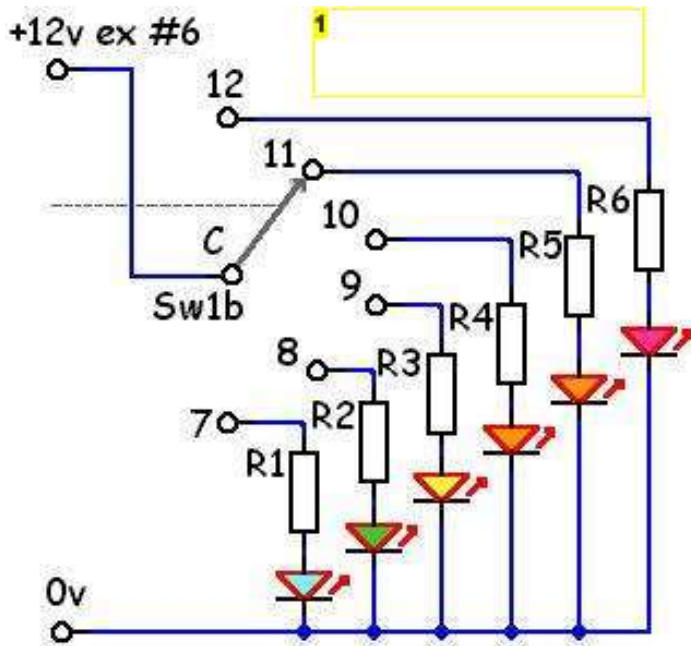

Image Notes

1. If the LEDs are different then a resistor is need for each LED.

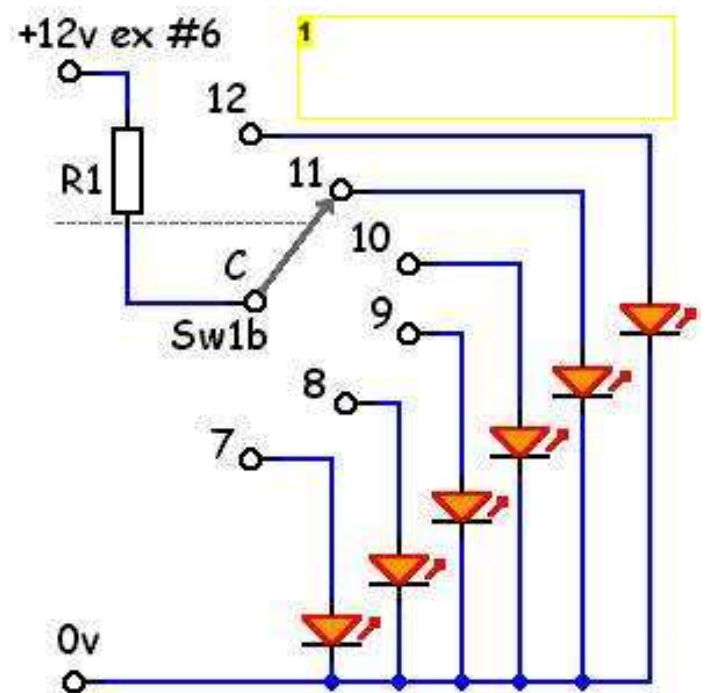

Image Notes

1. This version is good for higher power LEDs. If the LEDs are all the same then only one resistor is needed

step 2: Things you will need

You will need

- soldering iron
- solder
- wire
- 2P6P rotary switch. (a 1P12P will allow for more control but will not allow for LEDs)
- 6(or more)Diodes type 1N4001

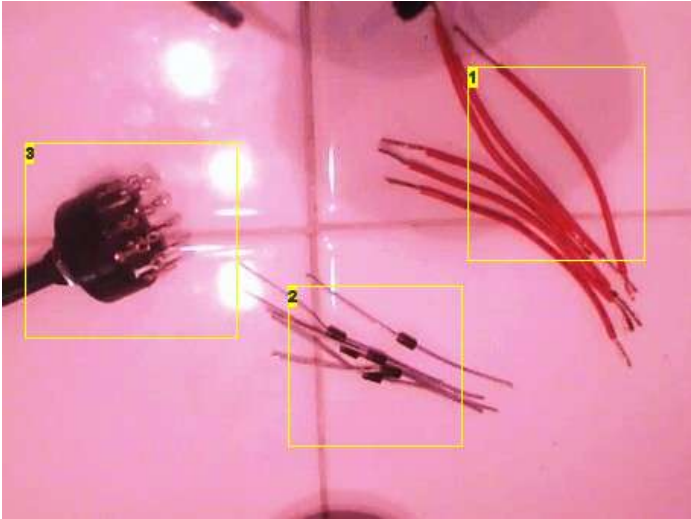

Image Notes

1. 6 wires
2. 5 diodes (could be more)
3. 2P 6P rotary switch

step 3: Wires for leds (optional)

The wiring positions for the LEDs on a 2P6P rotary switch are 7-12.

You can do like what I did for the LEDs or do them like the diodes in Steep 4 if you want to do a bar graph.

I added a wire to each position (7-12) Then did the diodes type 1N5817 Schottky diodes on a PC board.

I will show how to do the LEDs later on another Instructable.

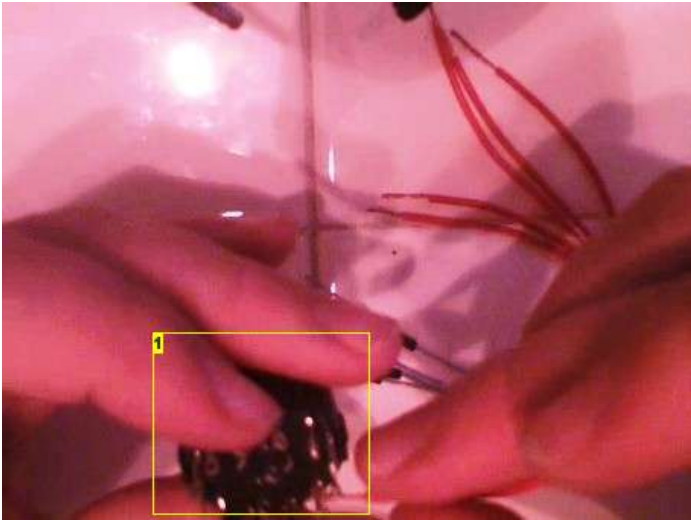

Image Notes

1. Little off screen. :) Start adding wires going from Postion 7 - 12.

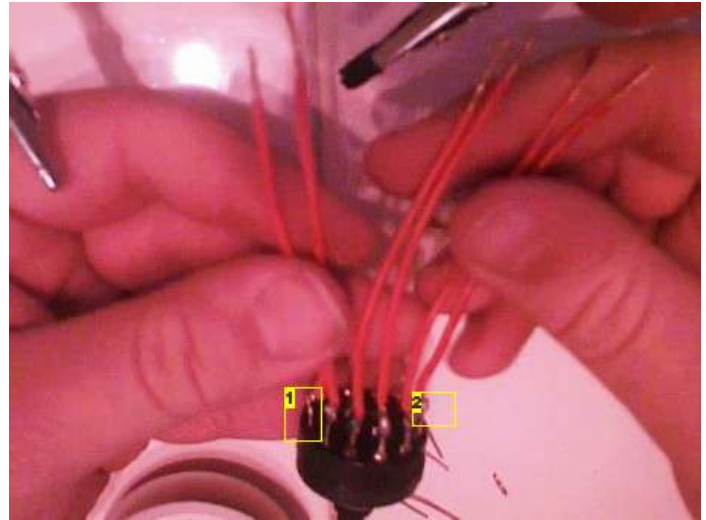

Image Notes

1. This should be 7
2. This should be 12

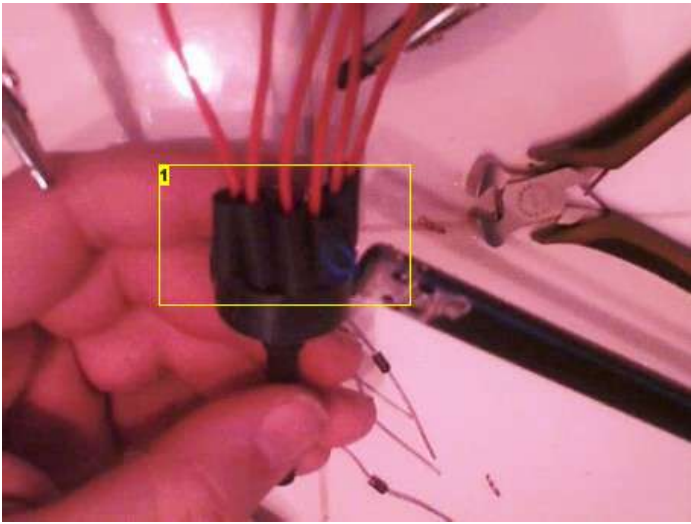

Image Notes

1. Heat shrink the soldering.

step 4: The Diodes

The are also options for doing the diodes for the fan control.

This is from the site

If you don't want lights, just use the left-hand section of the schematic, for pole 'A'. Using a 12-way 1-pole switch. This would allow the range to be extended, using single diodes between each position. You could then use 1A Schottky diodes, they drop under 0.5V per diode so would give smaller steps, and/or have an unconnected "off" position at one end.

For my switches I used 6 Diodes(Type1N4001). I did my wiring like this.

- no diode for full 12v
- 2 diodes
- 2 diodes
- 1 diode
- 1 diode
- No diode for off (later updated to 2 diodes for a very low speed)

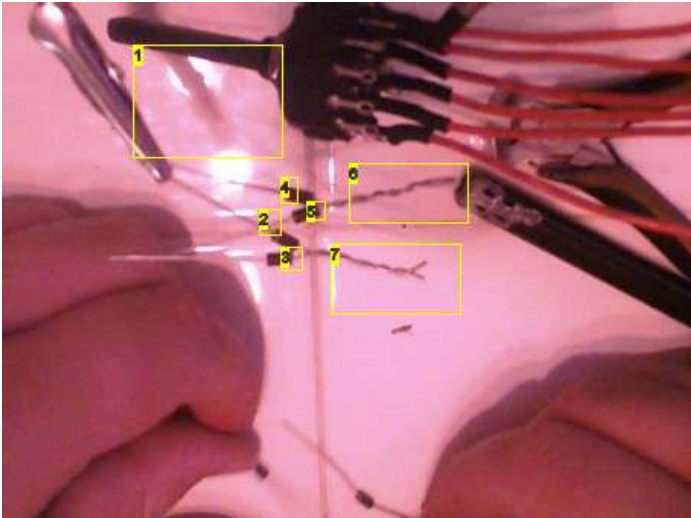

Image Notes

1. Sorry It is hard to see.
2. Band
3. Band
4. Band
5. Band
6. This gets soldered
7. This gets soldered

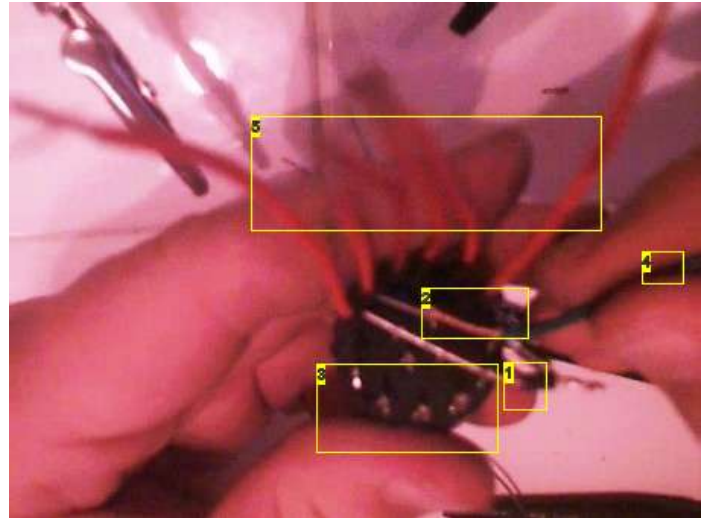

Image Notes

1. Position 6 get connected with the diode to position 5. The band on the diode points to next position.
2. These two get connected together with the 12v. Position C and 6.
3. This gets continued with the last of the diodes from 5 to 1.
4. 12v power
5. Connecting C will allow for you to do your LEDs

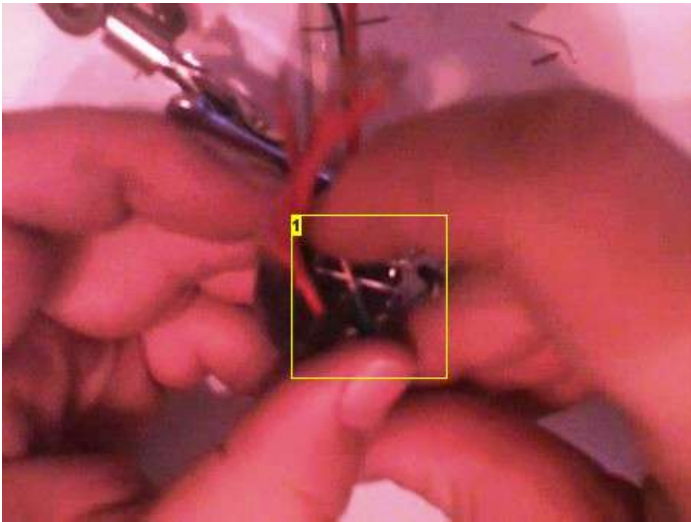

Image Notes

1. Add your wire for fan power this goes to Pos A. Finger is blocking it.

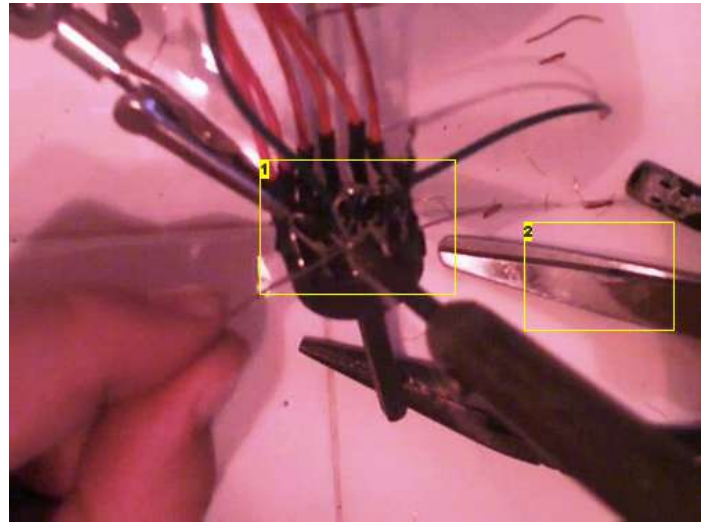

Image Notes

1. Solder everything up making sure that the bands on the diodes points to the next position. Going from 1 to 6
2. Use flat snips not scissors.

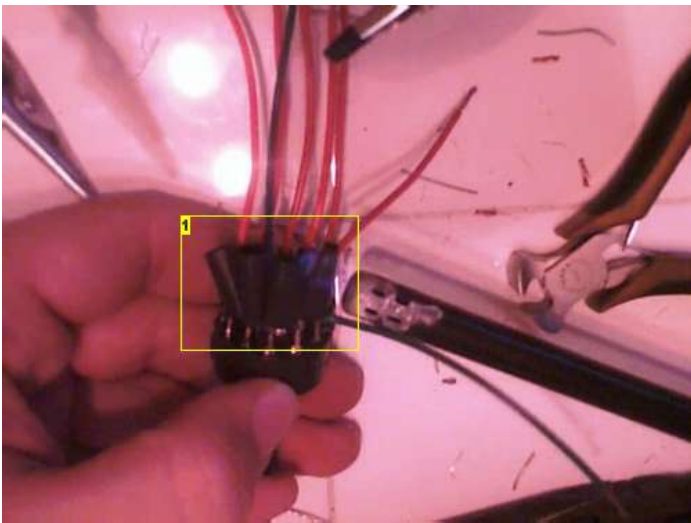

Image Notes

1. Heat shrink the soldering

step 5: Hack the old fan plug for new fan controller power.

I used the 2 pin power wire that came with the fan,

I removed the yellow and the black wire from the plug and sniped the old 2 pin power wire off at that end. Then stripped a red and a black wire for power and ground. Red wire was pushed into the hole in the molex pin and soldered the same thing for the black wire for ground. Afterward they were heat shrunk and pushed back into the molex plug.

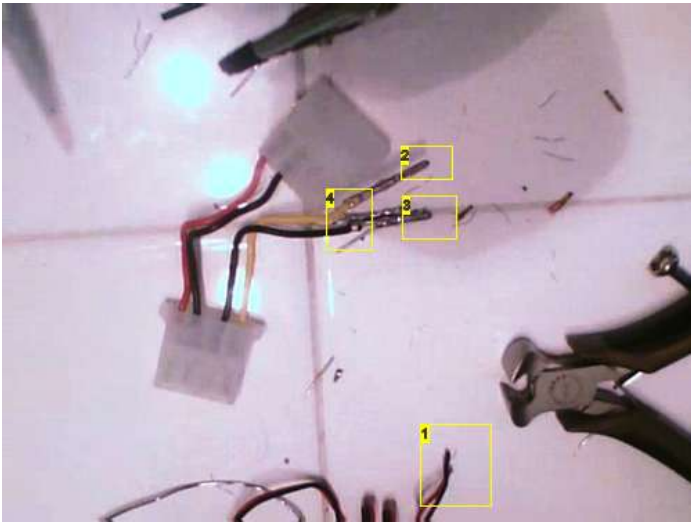

Image Notes

1. Clipped fan leads from molex power
2. 12v
3. Ground
4. the 2 wires from the fans where clipped from here

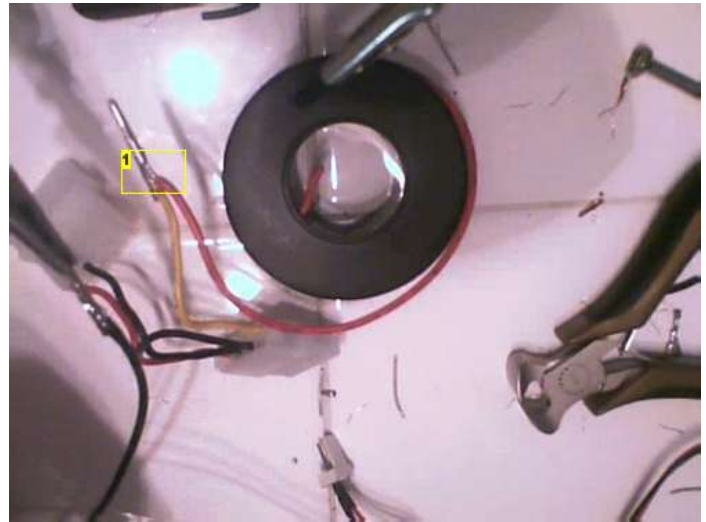

Image Notes

1. wire was pushed inside then soldered in place.

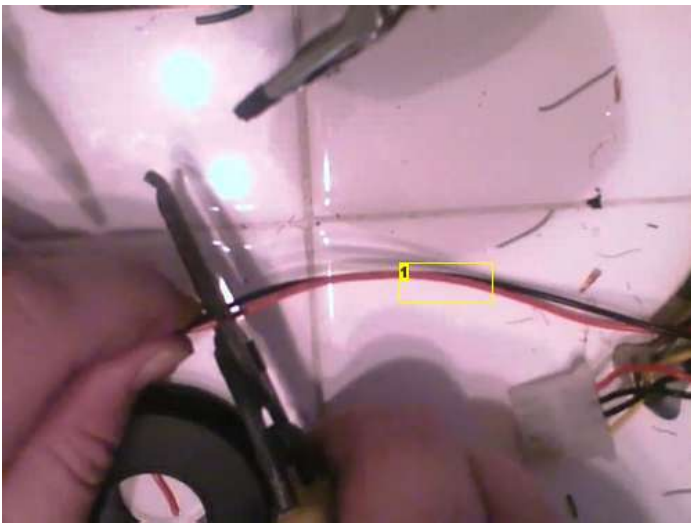

Image Notes

1. Cut it how long you need it.

step 6: Attaching power to fan controller and ground.

connect the ground on the molex to the ground to the fans 2 pin ground wire. Then the red wire from the plug goes to the wire on position 6 of the rotary switch. Position A gets attached to the power wire on the 2pin fan power wire. Then heat shrink.

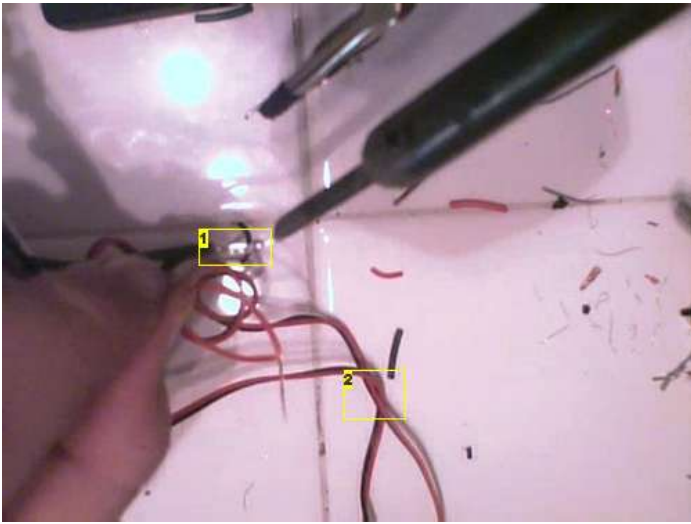

Image Notes

1. connect grounds together
2. The 2 pin fan cable with plug.

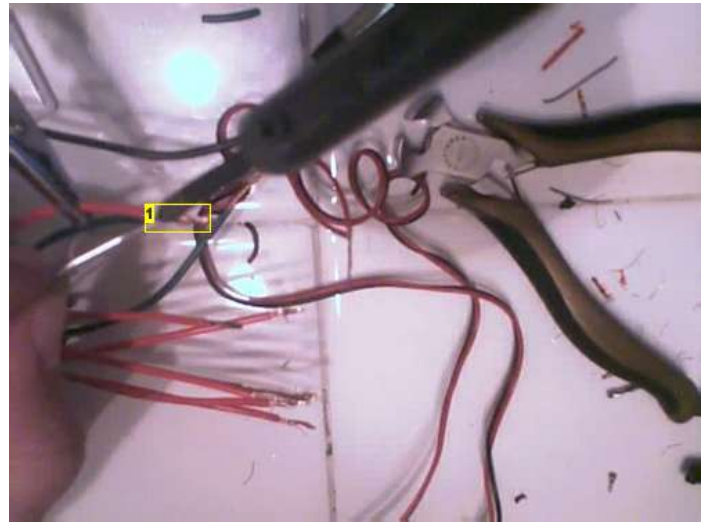

Image Notes

1. power goes to Position 6. This is the wire not in the middle that is position A.

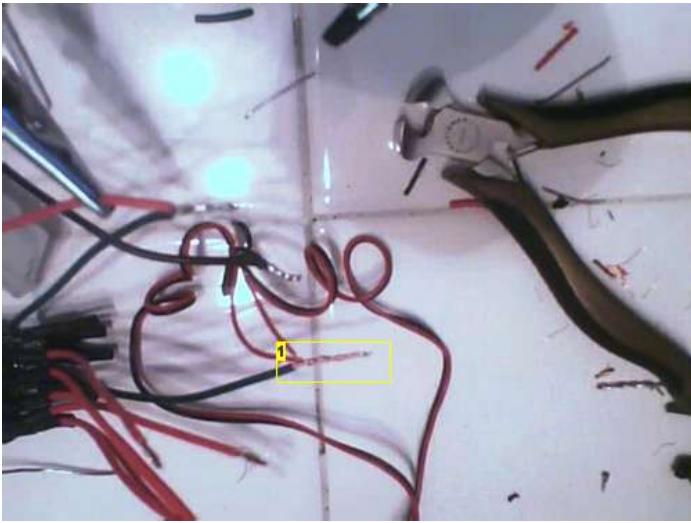

Image Notes

1. Position A gets attached to the fans power leads.

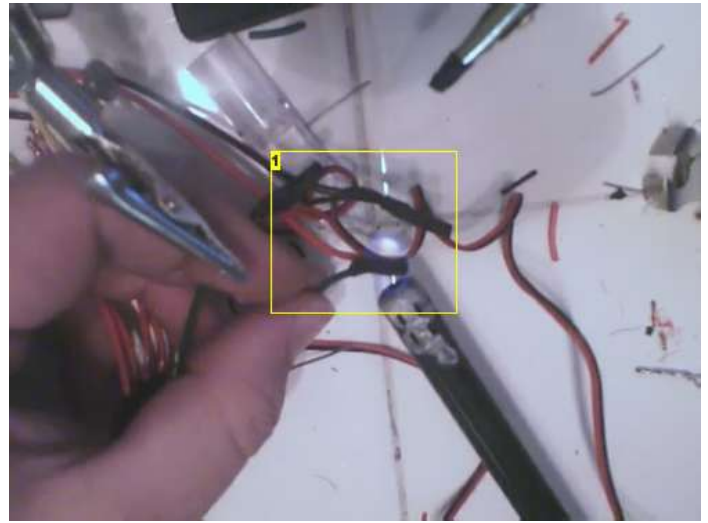

Image Notes

1. Heat shrink the soldering

step 7: Testing

Make sure all solder connection have heat shrink. Plug the fan in and then plug the molex in. You should now be able to control the fan with the rotary switch.

I will make a new instructible for doing the LEDs or add to this one later on. This is what I did with mine. I forgot to take pictures when I made it, but I am making one more.

Please Rate and Comment.

Thank You CPEMMA for letting me use pictures and text from your website.

Related Instructables



DC Power Supply (slideshow) by AJEVE



Cheap and cheerful switched case fans by pyper



Dual PCI slot fans with adjustable speed. by Technochicken



Very simple PWM with 555...Modulate every thing by shams



Magnetic Stirrer by g0pher



STEP 1 by jeffolly



Make Xbox Power Light Red Instead Of Green by 343GUILTYSPARK



Pimp my Pong by osgeld

Comments

9 comments

[Add Comment](#)



fate101 says:

What are those diodes just before the LEDs in the positions 11 and 12 of the SW1b in the first schematic? do you need to drop the voltage or something like that?

Oct 22, 2009. 8:51 PM [REPLY](#)



Rob K says:

Those are Schottky diodes. Each position puts out 12 volts but to have every LED on at the highest setting would require a higher voltage to keep it as a bar graph. So instead when a higher position is reached it turns on a second series of LEDs.

Oct 22, 2009. 11:13 PM [REPLY](#)



fate101 says:

Ah, so the diodes are there just to avoid the current to kinda make a "loop" and running the LEDs of the first chain in reverse-biased? (i think i got it now... the thing of the parallel connection for lowering the power requirements of the bargraph i've got from start=D)

Oct 23, 2009. 10:20 PM [REPLY](#)

btw, is nice to see speed controllers that dont require some IC. those are pretty hard to find for me D=



Rob K says:

I have not tried to bar graph the LEDs that way. I used the option with the Schottky diode per LED. I was also using 3.6 fv aqua LEDs and another circuit that was suppose to fade them that messed up.

Oct 29, 2009. 12:18 AM [REPLY](#)

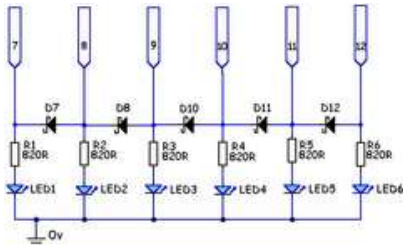

sdallesasse says:

Why not use zeners to regulate the voltages?

Nov 9, 2008. 2:01 PM [REPLY](#)



Rob K says:

I asked your question Cpeмма responded with.

Nov 11, 2008. 10:32 AM [REPLY](#)

In theory you could use zeners, but it's hard to find low values. A 2.4V 1.3W zener in place of the first pair of 1N4001 would be worth doing to give a bigger starting step (12V to 9.6V) and extend the bottom of the range to 6.6V



Rob K says:

I'm not sure on the zener diodes. I know you can use schottky diodes.

Nov 9, 2008. 10:34 PM [REPLY](#)



Phil B says:

I assume you are utilizing the property of a diode that drops the voltage across it by about 0.6 volts per diode.

Nov 9, 2008. 5:44 AM [REPLY](#)



Rob K says:

Yes it is, I forgot to add that in there. I will update the instructible.

Nov 9, 2008. 12:48 PM [REPLY](#)
