

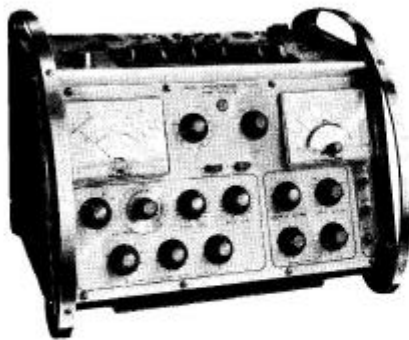

OPERATING
INSTRUCTIONS

**VALVE
CHARACTERISTIC
METER TYPE 163**



**AVO VALVE CHARACTERISTIC METER
TYPE V.C.M. 163**

AVO VALVE CHARACTERISTIC METER TYPE V.C.M 163

CONTENTS

CHAPTER 1	General Information	4
CHAPTER 2	Technical Information	6
CHAPTER 3	Valveholder and Control Panels	9
CHAPTER 4	Operating Instructions	13
CHAPTER 5	Abbreviated Operating Instructions	21

ILLUSTRATIONS

Figure 1	Basic Circuit for Mutual Conductance Measurement	7
Figure 2	Basic Circuit for Rectifier Test	7
Figure 3	Standard Pin Connections	10
Figure 4	Amplifier Circuit Diagram	22
Figure 5	Oscillator and Power Unit Circuit Diagram	23
Figure 6	Instrument Circuit Diagram	24

The Avo Valve Data Manual which is supplied with the instrument provides a line of data for each valve likely to be encountered. The data given comprises the pin combinations, in the order of their standard numbering and in the form in which they appear in the VALVE PIN SELECTOR switch window, top cap or side contact connection if any, heater volts, anode volts, screen volts, negative grid volts, operating anode current and mutual conductance (or load current in the case of a rectifier). Where multiple electrode assemblies are concerned test details for each assembly are given. Should it be necessary to test a valve that does not appear in the manual, the base connections and manufacturers' or other recommended test data can be directly set up.

CONSTRUCTION

The mechanical construction of the instrument has been designed to combine a pleasing streamlined appearance with a high degree of mechanical strength. All components likely to require adjustment or replacement in service are located to ensure maximum of accessibility. All main controls are front panel mounted and the instrument is supplied complete with mains lead.

Fourteen valve bases together with an additional SP14/S socket, which will accept a range of adaptors, is provided. A thirteen way, fifteen bank VALVE PIN SELECTOR switch enables any valve pin to be connected to any electrode circuit. The SELECTOR switch is marked with figures and letters which enable code numbers to be set up from the 'AVO' Valve Data Manual.

PERFORMANCE

The instrument will test valves with pin connections up to thirteen as follows:—

- (1) Check the heater continuity.
- (2) Measure insulation between electrodes with the valve cold.
- (3) Measure insulation between electrodes with the valve hot.
- (4) Measure cathode/heater insulation (for indirectly heated valves).
- (5) Rapidly indicate whether a valve is good or bad, use being made of a coloured replace/good scale with mutual conductance as the operative parameter.
- (6) Measure the mutual conductance of a valve. (Both control grid to anode and control grid to screen.)
- (7) Measure the anode and screen current in single and multiple valves.
- (8) Produce sufficient data to enable static and dynamic characteristic curves to be plotted.
- (9) Check rectifiers and diodes under load conditions.
- (10) Measure gas current up to 100 μ A f.s.d.

An automatic visual warning device operates if certain circuits within the instrument are inadvertently overloaded by the operator, or if a short occurs with a valve under test. The use of specially designed circuits, virtually eliminates the possibility of a valve under test bursting into spurious oscillation.

ADAPTORS

If the valve base required is not available on the valve panel, it will be necessary to use an adaptor. Adaptors which can be plugged into the SP14/S socket on the valve panel as follows:— UX4, UX5, UX6, UX7, MO8 and B7. Adaptors are also available for use with the International Octal Valveholder as follows:—5AA and 7AA (Acorn Valves) 6A7, B3G, B7A, B8B, Continental 8 pin (F8). Additional adaptors can be supplied to customers' requirements.

POWER REQUIREMENTS

The instrument operates from the following a.c. supplies:— 110V, 120V, 200-240V in 10 volt steps. Power supply frequency 50 to 60c/s. A fine voltage control is provided which compensates for mains voltage variation in two volt steps from —10 volts to +10 volts inclusive. Power consumption, 50 watts maximum.

**PRINCIPLES
OF OPERATION**

The tester is basically designed to check the valve according to its static characteristics which would normally require the provision of the requisite range of variable d.c. supplies. The difficulty lies in the regulation problems involved in the supply of a wide range of d.c. anode and screen voltage, on which the loading might vary from a fraction of a milliamp to 100mA dependent on the type of valve being tested and the nature of the test being performed. Such a requirement could, of course, be met by the provision of a number of regulated power supplies but this would render the instrument both cumbersome and expensive, whilst the considerable metering required would not only mean additional expense, but also make the instrument difficult to use and would not entirely overcome all the problems.

It can be shown however, that if alternating electrode voltages are applied in their correct proportions, an amplifying valve can (by virtue of its property of self rectification) be caused to give d.c. anode and screen currents, which for all practical purposes, bear an almost constant relationship to those obtained from its d.c. static characteristics.

This immediately simplifies the problem of providing power supplies for the valve under test and the design of mains transformers to give negligible regulation errors over a wide range of secondary currents is a comparatively simple matter, whilst the range of electrode voltage may be simply provided by appropriate secondary tapplings selected by calibrated switches. This eliminates the necessity for separate metering, thus minimising to a very large extent, problems of size, weight and cost.

A slight difficulty occurs in the supply of the variable negative grid bias voltage, which would normally consist of an alternating voltage of suitable magnitude applied in anti-phase to the anode voltage. Since rectification occurs at the anode (and screen) and the grid should not pass current, it will be readily seen that during the half cycle the anode and screen are not passing current a positive half cycle of considerable magnitude is applied to the grid with the result that the latter can pass a damaging amount of current. The inclusion of a simple half wave rectifier circuit without smoothing, between the transformer winding and the variable grid voltage supply, will suppress the positive half cycle whilst still maintaining the sinusoidal form of the operative negative half cycle.

The operation of the Valve Tester is based on the following relationship:—

$$\begin{aligned} \text{If applied r.m.s. anode (and screen) voltage} &= 1.11 \times V_a \text{ d.c.} \\ \text{and} & \\ \text{Mean value of half wave rectified bias voltage} &= 0.5 \times V_g \text{ d.c.} \\ \text{then,} & \\ \text{Mean d.c. anode current} &= 0.5 \times I_a \text{ d.c. (where } I_a \text{ d.c. is static} \\ &\text{anode current) if } V_a \text{ d.c. and } V_g \text{ d.c.} \\ &\text{were applied d.c. test voltages.} \end{aligned}$$

This relationship holds for all practical purposes over the full characteristic which enables accurate testing of valves, at any point on their characteristic to be carried out with simple and compact apparatus. This accuracy is just as necessary on the simple 'go'/no go' type of instrument as on a complete characteristic meter, as it may be necessary to set the test point anywhere on the characteristic to correspond to required working conditions. Further, in the absence of any predetermined test figure it must be possible to determine test conditions directly from the manufacturers' published curves or data.

**BASIC
CIRCUITRY**

One of the main functions of the tester is that of comparative testing of mutual conductance. This is accomplished by applying the appropriate anode, screen, grid and heater voltages to the valve and superimposing upon the grid bias voltage, a small signal at a high audio frequency. The anode current of the valve passes through a low impedance filter. This extracts the signal frequency component of the current and rejects the power frequency (and its harmonics). The signal frequency component is amplified and its mean value displayed on a meter. By suitable choice of circuit values this becomes a direct measure of the valve mutual conductance, this figure being compared with the nominal mutual conductance to give comparative goodness on a coloured scale. Fig. 1. shows this arrangement in diagrammatic form.

Facilities are provided for calibrating the oscillator/amplifier combination and the circuit is arranged such that the accuracy is dependant only on the ratio of resistor values.

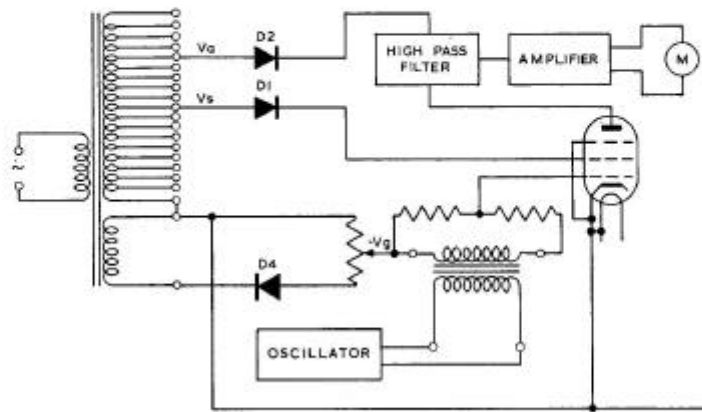

FIGURE 1
Basic Circuit
for Mutual
Conductance measurement

The maximum value of high frequency test signal applied to the grid of the valve is approximately 35mV r.m.s. on the 0 to 6mA/V range and the circuit is so arranged that the amplitude of the test signal is inversly proportional to the value of the mA/V range selected by the range switch.

The stopper diodes D1 and D2 shown in the screen and anode supplies in Fig. 1. are included as a precaution against spurious oscillations which have been known to occur with a few types of valve when anode or screen become negative to the control grid. Inaccuracies could occur if such oscillation is present.

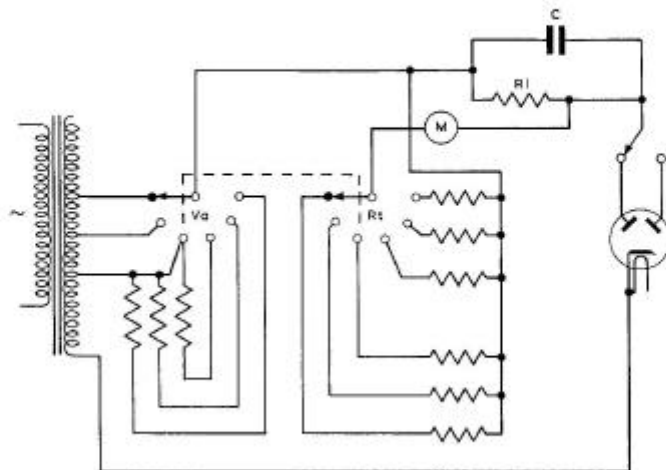

FIGURE 2
The basic circuit
of the
rectifier test

The rectifier is loaded with a resistor R_1 in Fig. 2, and a reservoir capacitor C in parallel. Sinusoidal voltage V_a is applied of sufficient magnitude to operate the rectifier on the linear portion of its characteristic, so that the combination should pass a rectified current equal to the maximum load current for the valve. The voltmeter M measures the voltage developed across the load R_1 in Fig. 2 and the meter ranges are selected by the appropriate range resistor R_t in Fig. 2 such that the rated current through the load will deflect the meter M approximately to the middle of the 'good' zone of the scale. The proportionate deflection on the coloured scale denotes the state of the valve. Switching of anode voltage and meter range is ganged so that rectified currents of 1mA, 5mA, 30mA, 60mA, 120mA, 180mA, per anode are available, each anode of a full wave rectifier being tested separately. The 1mA and 5mA ranges are also suitable for signal diode testing. Perfect diodes give approximately full scale deflection on each range. Small signal diodes, and small current, high voltage rectifiers, since they may be either of very high or very low impedance are catered for by special circuit arrangements which tend to be 'current forcing'. Hence low impedance diodes tend to read as perfect diodes at full scale deflection whilst high impedance diodes tend to read lower down on the 'good' region of the scale.

A combination of the positions marked on the LEAKAGE switch and the CIRCUIT SELECTOR switch provides facilities for checking heater continuity and cathode leakage prior to the application of operating voltages to the valve. In addition inter-electrode leakage may be measured with the valve hot with a maximum of 50V d.c. applied.

Since a short circuit, is in fact, a measure of the leakage test voltage (derived from the grid voltage supply) this is used in checking the setting of the mains voltage of the instrument at position SET \sim . At this position a short is placed on the insulation test circuit and the Mains Voltage Selector is adjusted until the meter pointer is at the SET \sim position, at which point the grid voltage and therefore all other operating voltages are correctly proportioned.

A safety relay having two heavy duty contacts in the primary circuit of the h.t. transformer and a current coil connected in the anode and screen circuits, will be operated by an overload, associated with either or both of these circuits. If the relay is operated, an additional light duty contact will 'make', to form a hold circuit and at the same time a blue warning lamp mounted on the front panel will be illuminated. As a further precaution, the two heavy duty contacts will break, disconnecting the h.t. transformer from the mains supply. Normal operation cannot be restored until the instrument is switched off, the fault should then be rectified and the instrument switched on again.

The problem of self oscillation, which can occur with high slope valves occurs at a random high frequency and is due to inter-valveholder wiring. This has been almost entirely eliminated by wiring the valveholder panel in continuous loops of pre-determined lengths, so that any valve inserted would tend to oscillate at a definite frequency dependent on the loop lengths. These separate inter-connection loops are then loaded with ferroxcube beads so that irrespective of the valveholder and pin combination used, oscillation cannot occur when testing valves with conventional characteristics.

**THE VALVE HOLDER
PANEL AND
VALVE PIN
SELECTOR
SWITCH**

The valveholder panel comprises 14 valveholders of the following type:—British 4/5 pin, (B4 and B5) B7G, B8A, B8D, B8G, B9D, B9G, International Octal, B10B, 5 pin Nuvistor, 7 pin Nuvistor, 12 pin Compactron, and a flying lead valveholder. In addition a SP14/S chassis mounting socket is provided for use with a range of adaptors thus enabling obsolete or new type valves to be tested. The following adaptors are available:—UX4, UX5, UX6, UX7, MO8, B7. Adaptors are also available for use with the International Octal valveholder as follows:—5AA and 7AA (Acorn valves) 6A7, B3G, B7A, B8B, Continental 8 pin (F8). Additional adaptors can be supplied to customers' requirements.

All valveholders are wired with their corresponding pins in parallel, i.e. all pins numbered '1' are wired together, all pins numbered '2' and so on. This wiring combination is associated with the VALVE PIN SELECTOR switch which enables any one of the thirteen standard pin numbers to be connected to any one of the electrode test circuits in the instrument, thus enabling any electrode combination to be set up for all valveholders.

It will be seen that the SELECTOR switch comprises fifteen thumb rollers numbered from left to right 1 to 13, TC1 and TC2. This numbering appears on the escutcheon immediately in front of the rollers and corresponds to the valve pins in the order of their standard pin numbering. Thus valves with any number of pin connections up to thirteen can be accommodated. To cater for top cap and other external valve connections two sockets have been provided together with short leads fitted at one end with a plug for insertion into the sockets, whilst the remote end is fitted with a universal connection clip to cater for most types of external valve connections. Also on the valve holder panel are three links marked a, c and h which enables a resistive load to be inserted in the appropriate anode or cathode circuits, and the current to be measured in the heater circuit.

The thirteen positions of each roller are marked as under:—

0	1	2	3	4	5	6	7	8	9	X	Y	Z
—	c	h—	h+	g ₁ '	g ₁ ''	g ₁ '''	g ₂	a	a _d '	a _d ''	a _d '''	a _d ''''

The numbers and symbols are provided in order that the switch can be rapidly set up from the code numbers given in the Avo Valve Data Manual, the corresponding electrode denominations being shown by the letter which appears in the escutcheon opening immediately below the number thus:—

0	Corresponds to a pin which should not be connected, and on which an internal electrode may be anchored. Such pins are marked, I.C.' in manufacturers' literature. This switch position leaves the particular valve pin disconnected from any circuit.
1 c	Corresponds to cathode or any other electrode normally connected to cathode i.e., g ₃ .
2 h—	Corresponds to heater, normally earthy or connected to negative, L.T. in the case of a battery valve.
3 h+	Corresponds to other heater connection or centre tap.
4 g ₁ '	Corresponds to control grid.
5 g ₁ ''	Corresponds to the control grid of the second section of a multiple valve.
6 g ₁ '''	Corresponds to the control grid of the third section of a multiple valve.
7 g ₂	Corresponds to the screen grid in a single or multiple valve.
8 a	Corresponds to the anode of single or multiple amplifier valves.
9 a _d '	Corresponds to the first diode anode of signal diodes, rectifiers or multiple electrode valves.
X a _d ''	Corresponds to the second diode anode of signal diodes, rectifiers or multiple electrode valves.
Y a _d '''	Corresponds to the third diode anode present in some valves.
Z a _d ''''	Corresponds to the fourth diode anode present in some valves.

LINKS ON THE VALVE HOLDER PANEL

These links are connected in the anode, cathode and heater circuits respectively. The links in the anode and cathode enable a load to be inserted in the appropriate circuit of the valve under test. By removing these shorting links, and inserting the required resistive load across the terminals which it is desired to include in the circuit, it is possible to obtain the dynamic characteristic of the valve or electrode system under test. The link in the heater circuit enables heater current to be monitored.

NOTES

- (1) Beware of possible high voltages on the shorting links.
- (2) Always ensure correct positioning and security of shorting links especially after replacement following use of circuit breaking facility.
- (3) Loads *other* than resistive must not be used under any circumstances.

CONTROL PANEL

All main controls are front panel mounted and for ease of use, switches associated with test functions have been mounted together and switches associated with electrode supplies are also grouped together. The controls and their functions are listed below:—

FUNCTION CONTROLS

The Circuit Selector switch This is a five position switch which determines the types of test to be undertaken on the instrument. All the necessary internal circuit connections are made automatically to satisfy the test conditions required, whilst internal test circuits unnecessary to the particular test in hand are removed from the valve. The switch positions on the CIRCUIT SELECTOR are:—

CHECK (C). At this position, in conjunction with the LEAKAGE and SET \sim switches (see below) the supply voltage is set to the correct operating value, the valve is also suitably connected for the cold electrode leakage test, and heater continuity.

CHECK (H). At this position, in conjunction with the LEAKAGE switch (see below) the valve under test can be tested for electrode leakage with the valve hot. The supply voltage can also be re-checked as above, without disconnecting the valve heater.

c/h INS: At this position, the valve is automatically checked for cathode to heater insulation with the heater voltage applied.

TEST: When set to this position and in conjunction with the ELECTRODE SELECTOR switch and other relevant controls the valve is tested for its normal characteristics. Also at this position and in conjunction with the appropriate settings of the ELECTRODE SELECTOR switch, signal diodes and rectifying valves can be checked.

GAS: At this position the mA meter is connected in series with the control grid connection, and a direct indication of any gas current flowing will be given on the meter. The 50 μ A meter movement is shunted to provide a full scale deflection of 100 μ A.

Electrode Selector Switch This switch, in conjunction with the CIRCUIT SELECTOR, enables the panel meters to be associated with the anode circuit under test. Triodes, pentodes and multiple grid valves are checked with the ELECTRODE SELECTOR switch set to a', a'', and a''' whilst diodes and rectifiers are checked at positions a_d', a_d'', a_d'', and a_d'''' as required.

Set \sim Switch This switch in conjunction with the \sim position on the LEAKAGE switch enables final mains voltage adjustment to be made, when the CIRCUIT SELECTOR switch is in either the CHECK (C) or CHECK (H) positions.

Leakage Switch This is a twelve position switch, which combined with the CIRCUIT SELECTOR switch enables the SET \sim control to be adjusted with the valve either hot or cold, provides an indication of heater continuity and also enables any electrode, from which leakage occurs to be ascertained. The relative switch positions are as follows:—

\sim At this position of the switch and with the CIRCUIT SELECTOR switch set to CHECK (C) or CHECK (H), (see above under 'Set \sim Switch'), the SET \sim control may be adjusted to the correct operating position as indicated by the meter.

h (C). At this position with the CIRCUIT SELECTOR switch set to CHECK (C) heater continuity, with the valve cold, will be indicated by a short on the insulation scale of the meter.

c (C). At this position with the CIRCUIT SELECTOR switch set to CHECK (C), cathode leakage with the valve cold, will be indicated on the meter.

At all remaining nine positions of the LEAKAGE switch, the electrode from which leakage may occur, will be indicated on the meter (with the valve either hot or cold dependent upon the position of the CIRCUIT SELECTOR switch). With the CIRCUIT SELECTOR switch set to CHECK (C) any leakage will be with the valve cold and with the CIRCUIT SELECTOR switch set to CHECK (H) the leakage indicated will be with the heater voltage applied.

ELECTRODE SUPPLIES

Heater Volts Heater voltages are selected by means of three switches, enabling a fine adjustment of heater voltage to be obtained. One, a twelve way rotary switch is scaled from 0 to 110 volts in ten volt steps, the second, a ten way switch, covers 0 to 9 volts in 1 volt steps and the third switch covers 0 to 0.9 volts in 0.1 volt steps. The values of voltage covered by these three switches are additive, thus the heater voltage may be set to any value between 0 and 119.9 volts in increments of 0.1 volts.

Anode and Screen Volts These switches enable the requisite electrode voltage between 12.6 and 400 volts to be applied to screen and anode of valves for the purpose of carrying out valve characteristic measurements.

Grid Volts Control of grid voltage is by means of a variable potentiometer and an associated four position switch which enables the negative grid volts for the valve under test to be set up to any value between 0 and minus 100 volts. Four ranges are provided, 0 to 3, 0 to 10, 0 to 30, and 0 to 100 volts.

OTHER FACILITIES

mA Switch Operation of this switch allows the valve anode current to be measured in milliamps on the ranges covered by the section of the switch marked Ia, i.e. 3, 10, 30 and 100mA f.s.d.

On the ranges covered by the D/R Section of this switch, diodes and rectifiers are loaded for the nominal current in milliamps stated at each position, i.e. 1, 5, 15, 30, 60, 120, and 180 mA. The quality of the diode/rectifier is then indicated on the coloured scale of the meter marked 'Diodes and Rectifiers'.

NOTE: The calibration marks on the diode rectifier switch are purely nominal and are approximate test currents only.

At the position of this switch marked with a dot and when the CIRCUIT SELECTOR switch is set to the TEST position, both meters are shorted out. This provides protection for the meter movements during transit.

mA Meter Linear scales calibrated 0 to 100 and 0 to 30 are provided for the measurement of anode and screen current. A further scale calibrated in megohms indicates measurements of insulation resistance. The SET ~ position is also marked on this scale at which position the final mains adjustment is made. A coloured good/replace scale indicates the quality of rectifiers and diodes under test.

mA/V Switch The switch selects the appropriate scale of the mA/V meter, i.e. 6, 20 or 60mA/V full scale deflection. With this switch set to the position marked 'CAL' a calibration check is provided for the mA/Volt meter. At the 'CAL' position the pointer should lie on the red calibration line marked CAL. Adjustment is provided by potentiometer RV1, which is visible when the plug button is removed from the right hand side panel of the instrument.

mA/V Meter This meter is provided specifically for the continuous monitoring or comparative testing of mutual conductance. Continuous monitoring is provided on the 3½in. main scale of the meter calibrated 0 to 6 and 0 to 20 while a second smaller scale, proportionally related to the main scale, together with a coloured good/replace scale provides facilities for the comparative testing of mutual conductance.

With the indicating arrow on the coloured scale set to the nominal mutual conductance figure on the smaller calibrated scale, the dividing line between the red and green sections of the coloured scale will be positioned at half this value on the main scale. Should the value of mutual conductance be less than 50% of the nominal value, the meter pointer will lie in the red zone of the coloured scale and a reject valve will be indicated.

Push Buttons The two push buttons g₂ associated with the mA and mA/V switches enable screen parameters to be monitored on the relevant meter. With the mA switch set to a range in the Ia sector, depressing the associated g₂ button monitors screen current. Depressing the push button associated with the mA/V switch, when it is set to any position except the one marked CAL, monitors the screen mutual conductance. Both switches must be held depressed whilst measurements are taken.

Lamps The red SUPPLY lamp will be illuminated when the mains supply is connected to the instrument and the mains switch is set to the ON position. The blue OVERLOAD lamp will be illuminated should the safety relay be operated by a faulty valve or inadvertent overload.

**THE CONNECTION
OF THE
INSTRUMENT TO A
SUPPLY
VOLTAGE**

Ascertain the voltage of the mains supply and set the MAINS VOLTAGE SELECTOR. Access to the VOLTAGE SELECTOR PANEL can be gained by removal of the left hand side panel which exposes a COARSE VOLTAGE SELECTOR marked, 110, 120, 200, 210, 220, 230 and 240V. The fuse should be inserted in the position which is marked with the nearest value to the supply voltage available. Ensure that the instrument is switched off whilst the adjustments are made.

Connect the mains lead of the instrument to the power supply. Set the MAINS switch on the panel to its 'ON' position, and observe that the red panel indicator lamp is illuminated. The valve to be tested should NOT be inserted at this stage.

**FINAL SETTING
OF THE MAINS
VOLTAGE SELECTOR
PANEL**





Set the CIRCUIT SELECTOR switch to the position CHECK (C) and the LEAKAGE switch to ~. The mA meter pointer should now move across the scale and come to rest near the black region of the insulation scale denoting zero ohms. Rotate the SET ~ control until the meter pointer is as near as possible to the red line marked ~ in the middle of this black scale marking. If the initial setting of the mains voltage selector is correct, it will be possible for the meter pointer to be moved to either side of the red line using the SET ~ control. If this is not possible and rotation of the SET ~ control does not enable the pointer to reach the ~ mark from either direction, then the initial mains setting should be moved to the next appropriate tapping, the next higher tapping if the pointer is too far right of the ~ mark, and in a similar manner it should be moved to the next lower tapping if the pointer is to the left of the SET ~ mark. Once the mains voltage setting has been correctly set, provided extensive mains fluctuations do not occur, test voltages are automatically correct throughout the instrument.

**PROCEDURE
FOR SETTING
UP VALVE BASE
CONNECTIONS**

The procedure for setting up a valve for test is as follows:—

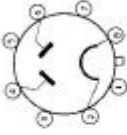
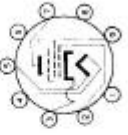
From some suitable source i.e., the 'AVO' Valve Data Manual, Manufacturers' Valve Data or any other Manual of Valve data, determine the pin connections for the Valve. Rotate the roller of the VALVE PIN SELECTOR switch until the code number or electrode letter combination appears in the window, reading from left to right in accordance with the standard pin numbering sequence. When a valve has less than 13 pins the free rollers on the right of the set up combination correspond to non-existent valve electrodes, and should be set at 0. (See also Chapter 3.)

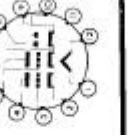
The accompanying examples show how to correlate the base pin data and the equivalent number for various valves in common use.

VALVE TYPE	VALVE PIN SELECTOR SWITCH CODE	TOP CAP	BASE
Osram U50 Full Wave Rectifier directly heated Octal Base	0 2 0 X 0 9 0 3 0 0 0 0 0 — h- — a _d ' — a _d ' — h+ — — — — —	0 0 — —	
Mullard EL84 High Slope Pentode	0 4 1 2 3 0 8 0 7 0 0 0 0 — g ₁ ' c h- h+ — a — ε2 — — — — —	0 0 — —	
Mullard ECC 81 Miniature High Slope Double Triode (Heaters wired in parallel)	8 4 1 2 2 8 5 1 3 0 0 0 0 a g ₁ ' c h- h- a g ₁ '' c h+ — — — — —	0 0 — —	
6 GA7 Compactron Diode Pentode	2 7 7 4 1 0 8 1 0 0 9 3 0 h- g ₂ g ₂ g ₁ ' c — a c — — a _d ' h+ — — — —	0 0 — —	
6B10 Compactron Double Diode Twin Triode	2 1 4 8 5 8 1 9 1 X 0 3 0 h- c f ₁ ' a g ₁ '' a c a _d ' c a _d '' — h+ — — — —	0 0 — —	
6K8 Triode Hexode frequency Changer	0 2 0 0 5 8 3 1 0 0 0 0 0 — h- — — g ₁ '' a h+ c — — — — — 0 2 8 7 4 0 3 1 0 0 0 0 0 — h- a g ₂ g ₁ ' — h+ c — — — — —	0 0 — — 5 0 g ₁ '' —	

**USING THE
AVO VALVE DATA
MANUAL**

The following notes are given to assist users of the Avo Valve Data Manual, particularly when testing multiple electrode valves.

- (a) **Abbreviations** The abbreviations in the Avo Valve Data Manual are as follows:—
- | | |
|------------|--|
| V_a | — Anode Voltage |
| V_{g1} | — Control Grid Voltage |
| V_{g2} | — Screen Voltage |
| I_a , mA | — Anode (plate) Current in milliamps |
| gm, mA/V | — Mutual conductance in milliamps per volt |
| V_f | — Heater or Filament Voltage |
| R_a | — External Anode Load Resistance. |
- (b) **Multiple Electrode Valves.** For multiple electrode valves such as rectifier pentodes the first line of data given for any one of these valves refers to the rectifier section of the valve.
- (c) **Double Electrode Valves.** When testing double electrode valves such as triode hexodes, triode pentodes, or dissimilar double pentodes, the upper line of data given for these particular valves, always applies to the triode section of the triode hexode or triode pentode or to section 1 of dissimilar double pentodes. The lower line of data refers to the hexode or pentode section or to section 2 of double pentodes.
- (d) **Dissimilar Treble Pentodes.** For these valves the upper line of data for any particular valve refers to section 1 (and also to section 2 or section 3 if they have the same characteristics as section 1). The lower line of data applies to the remaining section.
- (e) **Quadruple Diodes.** For a small number of these valves, i.e., 6JU8, the anodes of diodes 1 and 3 are coupled internally to the cathodes of diodes 2 and 4. In such cases two Valve Pin Selector switch codings are given in order that each diode may be tested separately.
- (f) **Variations of a Basic Valve Type.** These variations are indicated by a suffix to the basic type designation. These suffixes indicate only mechanical differences and do not affect the basic parameters as measured on the Valve Characteristic Meter. In these cases it is company policy to indicate only the basic type in the Avo Valve Data Manual. For information we give below a list of the suffixes in more general use:—
Basic Type—6L6 included in the Avo Valve Data Manual.
Basic Types with suffixes—6L6A, 6L6B, 6L6G, 6L6GT, 6L6GTA, 6L6W, 6L6WGT, 6L6WGTA. The 'e' are not included in the Avo Valve Data Manual.
- (g) **Grid Bias Voltage Not Given.** For some valves a grid bias voltage is not given as manufacturers do not recommend the use of a fixed bias voltage for these valves. This applies particularly in the case of high slope, frame grid valves when a very small change in grid voltage would result in a very great increase in anode current. In these cases it is suggested that the grid voltage is adjusted until the correct value of anode current is obtained.
- (h) **Tuning Indicators.** Valve Data for tuning indicators is now contained in the main section of the Valve Data Manual and not in the appendix as in the Valve Data Manual for the VCM Mk.4. The target volts are given in the V_{g2} column, and the value of load resistor in the Addenda column.
- (i) In the column headed 'Top Cap', figures are inserted in place of electrodes, to conform with the engraving on the roller selectors. For a valve having no top cap the code '00' is used.

**SETTING UP
THE INSTRUMENT
FROM
MANUFACTURERS
DATA**

The following notes are given to assist users of data other than the Avo Valve Data Manual.

- (a) For valves with pins which are internally connected, the appropriate roller of the valve Pin Selector switch should be set at 0.
- (b) If using data issued by United States or other manufacturers the term 'transconductance' replaces 'mutual conductance'. Transconductance (given in micromhos) divided by 1000, gives mutual conductance in mA/V, i.e.,

$$\text{mA/V} = \frac{\text{Transconductance (micromhos)}}{1,000}$$

anode current of a valve is unknown, the mA switch should be set to 100mA, to avoid possible damage to the meter movement if the current flowing exceeds the mA switch setting. The mA switch may be set subsequently to lower full scale current if required. A silicon diode connected in the shunt across the meter terminals provides some degree of protection against overloading the meter movement.

For mutual conductance testing the instrument should be set up as follows:—

Set Grid, Screen and Anode voltage to the value indicated in the Valve Data Manual. Set the ELECTRODE SELECTOR to the desired anode, the mA switch to the appropriate Ia range, and the CIRCUIT SELECTOR switch to TEST. This last switching operation applies electrode voltages to the valve. Anode current will be indicated on the appropriate mA meter scale and the value of mutual conductance will be displayed on the mA/Volt meter. Further sections of the valve may be tested with the ELECTRODE SELECTOR set to other appropriate anode positions.

By depressing the g_2 button, screen current or screen mutual conductance will be displayed. The push buttons must be held depressed whilst measurements are taken.

NOTE: Should the overload relay operate, (indicated by lighting of the blue OVERLOAD lamp), switch off and check for incorrect setting of the SELECTOR switch or electrode voltages. If these are correct but the relay continues to operate when the instrument is switched on again, the valve is probably soft (gassy) and the test should proceed no further. Switch off and remove the valve under test. When switched on again the instrument should function normally.

To check the relative goodness of the valve, using the coloured comparison scale ascertain the rated value of valve mutual conductance from the Avo Valve Data Manual or manufacturers' data and set the arrow of the coloured scale on the mA/V meter to this figure on the smaller scale. This will automatically set the dividing line between the red and green sections of the coloured scale, at 50% of this value on the main scale, i.e., if the arrow is set to three on the smaller scale the dividing line between the red and green sections will lie at '1.5' on the main scale. If the measured mutual conductance is less than 50% of the rated figure the meter pointer will lie in the red or reject section of the scale. If however, the measured value of mutual conductance is greater than 50% of the rated value the meter pointer will lie in the 'GOOD' section of the coloured scale.

VALVE CHARACTERISTIC MEASUREMENTS

To provide more comprehensive information, the plotting of one, or a family of mutual characteristics, can be readily undertaken with this Valve Characteristic Meter. The CIRCUIT SELECTOR should be set to position TEST when the value of the appropriate electrode currents can be plotted relative to the setting of the associated electrode voltage switches. Ia/Vg curves will be taken at predetermined setting of anode and/or screen volts, the reading of the anode current obtained being plotted against the setting on the variable grid bias controls. Similarly Ia/Va curves will require a fixed setting of grid bias, anode current being plotted against the setting of the anode voltage switch. For characteristic curves for the screen g_2 of the valve the push button associated with the mA switch will need to be operated.

Dynamic characteristics may be plotted similarly using selected anode and cathode loads connected at the appropriate links on the Valve Panel. When setting up for these tests the following points should be noted:—

- (a) A capacitor should not be included in the cathode load as this could result in smoothing of the cathode waveform, and resultant errors in measurements.
- (b) When setting Vg it may be necessary to make allowance for the voltage dropped across the cathode load.
e.g. From the Avo Valve Data Manual the test data for a Valve Type ECC 34 is:—
Vg = 16 volts, Ia = 10ma
Assuming an Rk of 500Ω, the voltage dropped across Rk would be 5V. In this instance the GRID VOLTS control should be set to 11V to provide the required Vg of 16 volts.
- (c) For the tetrode and pentode testing the circuit is arranged such that the screen is not decoupled and this should not be attempted.

Additional information for multiple or special types of valve will be found in subsequent notes.

**MEASUREMENT
OF GRID
CURRENT**

The measurement of grid current may be made after measuring the mutual conductance. This measurement should not be made where an apparent fault in the valve has previously caused the protective relay to operate (probably due to softness).

With the **CIRCUIT SELECTOR** switch set to **GAS**, the meter will indicate grid current directly in μA . The meter reads a maximum of $100\mu\text{A}$ f.s.d. but it is not possible to state the value at which a valve becomes useless due to presence of gas. This will depend entirely upon the circuit in which it is to be used.

**INSTRUCTIONS
FOR TESTING
SPECIFIC
TYPES**

The function of a valve, as distinct from the type number given to it by its manufacturer is indicated by a symbol in the form of letters appearing at the right of the test data given in the 'AVO' publications, e.g., a half wave rectifier is marked 'R' whilst a full wave rectifier is designated by 'RR'. In a similar manner, diode valves are shown by the letter 'D', the number of the diode elements being indicated by the number of 'Ds', e.g., 'DDD' refers to a triple diode.

**CHECKING
POWER
RECTIFIERS**

The testing of rectifying valves should ideally be associated with the requirements of the circuit in which they are to operate. In most cases throughout the 'AVO' Valve Data Manual, the figure quoted denotes the standard emission per anode to be expected from the type of valve under test.

Insulation checks may be made as already described. The mA switch has a number of positions grouped together and labelled D/R, the figure marked in these positions being the emission in mA expected per anode of the valve under test. To check load current the mA switch should be set to the load current given for the valve in the Valve Data Manual. Set **CIRCUIT SELECTOR** to **TEST** and the **ELECTRODE SELECTOR** either to a_d' in the case of a half wave rectifier, or a_d'' then a_d''' for a full wave rectifier. The quality of the valve will then be indicated directly on the replace/good scale of the mA meter.

The setting of the mA switch can either be determined from the tabulated data given, or can alternatively, be related, to the total current that the valve is required to deliver. Thus, on a piece of equipment where the total h.t. drain on the rectifier is 50mA, then a rectifier load setting of 60 will be an adequate test of the valve's emissive state, assuming that it is a half wave rectifier. Alternatively, if the valve is a new one, the maker's rating for maximum load current can be used as the basis for setting the mA switch.

In the case of full wave rectifiers, each anode of the valve is rated independently and the setting of the mA switch should indicate half the total value of the current which the valve should be expected to deliver in a full wave rectifier circuit, e.g., a valve rated at maximum of 120mA would be tested with each anode at the 60mA position. The load rating given in the Valve Data Manual is the load per anode.

**CHECKING SIGNAL
DIODES**

Signal diodes are checked in exactly the same manner as rectifiers, except that the mA switch is always set to 1 or 5 according to the anode current figures given in the data. (Where 'AVO' Valve Data does not give a current figure for a diode, it is always checked with the meter switch set to its 1mA position).

**MULTIPLE DIODES
AND RECTIFIERS
(D, DD, DDD, DDDD, R, RR)**

The testing of multiple diodes and rectifiers is carried out in the manner already explained, the **ELECTRODE SELECTOR** being used to select the particular diode or rectifier section, the emission of which is indicated on the mA meter replace/good scale.

**DIODES AND
RECTIFIERS
COMBINED WITH
OTHER
ELECTRODE
ASSEMBLIES
(DT, DDT, DDDT, DP, DDP,
DTP)**

Combined diodes and amplifying valves are represented in the type column of the Data by 'DT', 'DDT' and 'DDDT' for diode triodes, double diode triodes and triple diode triodes, whilst 'DP' and 'DDP' indicates diode pentodes and double diode pentodes and 'DTP' diode triode pentodes.

The testing of the separate sections of each valve is carried out in rotation with the **CIRCUIT SELECTOR** at **TEST** and the **ELECTRODE SELECTOR** at position a' , a'' , or a''' as required.

The rotation of the **ELECTRODE SELECTOR** to the a_d' , a_d'' , a_d''' or a_d'''' position will automatically set the instrument in readiness for testing the selected diode with the mA switch set to 1 on the D/R scale.

An indication of failing emission will probably give the most useful results. As a subsequent test, therefore, it is helpful to note the anode current at the rated test figures with the nominal heater voltage applied, and then to decrease the heater voltage by approximately 15% for a short period. In the case of a valve with a failing emission, the decrease in cathode temperature will result in an excessive decrease in the anode current, considerably greater than the percentage decrease in heater voltage.

CHECKING COLD CATHODE RECTIFIERS (CCR)	<p>Cold cathode rectifiers, designated by the symbol 'CCR' can be tested in a similar manner, but in this instance, a limiting resistance is required in the anode circuit. Values of anode voltage, approximate anode current and load resistance are given in the Valve Data Manual. The anode shorting link should be removed and the recommended value of load resistor should be connected across the terminals.</p>
DOUBLE TRIODES AND DOUBLE PENTODES (TT, PP)	<p>Double triodes and double pentodes are indicated by the letters 'TT' and 'PP', each section being tested in the normal manner. Selection of each assembly is made by the rotation of the ELECTRODE SELECTOR switch to a' and a'' (section under test). When double valves are used in class 'B' or 'balanced' circuits, a close match of the characteristics of both halves is essential.</p> <p>When measuring the screen current of double pentodes having either common or separate screen grids and separate control grids, it is necessary to switch from a' to a'' in order to transpose the bias and cut-off voltages from the control grids. When testing valves having a common control grid but separate screen grids, it is necessary to open circuit the anode and screen not being tested, otherwise the measured current will apply to both sections.</p>
FREQUENCY CHANGERS (H, TH, O, TP.)	<p>These valves are tested as two separate assemblies, separate data being given for each assembly in the Valve Data Manual.</p> <p>The ELECTRODE SELECTOR should be set to a' when checking the triode section and to a'' when checking the pentode section.</p>
CHECKING TUNING INDICATORS (TI)	<p>Tuning indicators (magic eyes) are tested with the controls set to the figures given in the data table, the SCREEN VOLTS switch being used to obtain target volts (V_{g2} in the Avo Valve Data Manual) and the appropriate anode load inserted in accordance with the value shown in the addenda column. At the approximate bias given in the table the triode section should be at 'cut-off' and the eye fully closed. Reducing the grid bias to zero, the eye should open fully and the value of the anode current should approximate to that appearing in the table (where given). In the case of double sensitivity indicators giving multiple images responding to different sensitivities, two sets of data (where possible) are given, the first set referring to the more sensitive indication.</p>
THYRATRONS	<p>Small thyratrons can be checked by comparison, if set up as a normal triode, but with a limiting resistor included in the anode link, the control ratio being indicated by a comparison between the peak value of the applied anode voltage and the setting of the grid bias control which will prevent the valve striking and passing anode current. It must be emphasised, however, that the main value of such a test is in comparison only, as the hold-off grid bias value shown on the grid bias control is only approximately half that of the bias which would normally be required to hold off the anode current of the valve at the peak anode voltage in question. In the data columns where information is given on the common thyratrons, it will be seen that this comprises a VALVE PIN SELECTOR switch number, Heater voltage, Anode voltage, expected Anode current, and the value of the limiting resistor required which will be found in the addenda column. The resistor should be of suitable wattage and connected across the link terminals before the valve is inserted in its holder. Grid volts should be at their maximum setting. With the mA switch set to '100' on the Ia section, the ELECTRODE SELECTOR at a' and the CIRCUIT SELECTOR at TEST, the bias on the valve should be reduced until the valve strikes and anode current flows. A good valve will pass, approximately the anode current given in the data. (If necessary reduce setting of mA switch.) This test is suitable as an emission check on thyratrons used in television and commercial radio equipment.</p>
NEON INDICATING LAMPS	<p>Neon indicators may be tested for striking, by setting up the VALVE PIN SELECTOR switch so that anode and cathode pins of the tube are set to 8 and 1 respectively, all other rollers being connected to 0. A suitable load resistor (normally between 5,000 and 15,000 ohms) should be included in the anode circuit link and the anode voltage switch should be set to a peak value as near as possible to (and in no cases lower than) the striking voltage of the neon in question. The striking of the neon will of course be indicated by a passage of anode current. The mA switch should be set to '100' on the Ia section. It should be noted that where the anode voltage refers to the peak applied voltage, as in the case of thyratrons and neons, the actual peak voltage applied to the valve is higher than the indication on the anode voltage switch. To obtain the peak voltage equivalent to a given setting of the anode voltage switch the figure shown on the switch should be multiplied by approximately 1.5; thus with the anode voltage switch set to represent a d.c. voltage of 100V the peak applied voltage is approximately 150V.</p> <p>NOTE: It is not recommended that Neon reference or stabiliser tubes are tested on this instrument as the valve manufacturers' state that the application of a.c. potentials may damage the valve under test.</p>

**GENERAL
PRECAUTIONS
TO BE OBSERVED
WHEN USING
THE VALVE
CHARACTERISTIC
METER**

It will be realised that when dealing with an instrument such as the Valve Characteristic Meter with such flexibility of control, it is almost impossible to protect the instrument to such an extent that the operator cannot cause damage to either the valve or the instrument by some combination or wrong setting of the controls or incorrect use of the instrument. It is, therefore, important that the correct procedure, as previously outlined should be used in the sequence of the tests applied. Valves should be tested for insulation or breakdown before full voltages are applied for characteristic tests. Where any doubt whatever exists as to the probable electrode current likely to be passed, the mA switch, should always be set to its highest current range and then gradually reduced in order to facilitate reading of the electrode current.

In experimental work where a variable voltage is required to be applied to the anode or screen electrodes of the valve, always start with the lower voltage tapings and increase only after correct adjustments have been made to the mA switch to ensure that the meter circuit is not overloaded by an unknown current. Always make sure that the VOLTAGE SELECTOR switches have been correctly set for the valve before the instrument is switched on again. In this respect it is good practice to return the VOLTAGE SELECTOR switches to their minimum position (particularly HEATER VOLTAGE switches) after a test has been applied and before a new valve is inserted.

Take care in setting the VALVE PIN SELECTOR switch to avoid wrongly connecting the electrodes of the valve under test. In this respect the automatic cut-out is advantageous in that it will usually protect a valve if high tension voltage is inadvertently applied to the heater by incorrect setting of the switch but it must be pointed out that after the switch is correctly set, nothing can save the heater from being burnt out if an overload heater voltage is applied by incorrect setting of the heater voltage switches.

Do not apply test voltage to the valve without ensuring, that where necessary, top cap connections have been correctly made, as a valve can often be irreparably damaged by running it with its grid or anode wrongly connected.

Where a valve appears to be performing abnormally, as indicated for instance by a continuously rising or falling anode current which does not attain a condition of stability, do not leave the valve on test for a long period to see what will ultimately happen, as this will in all probability result in the damaging of the valve due to excessive currents in the anode or screen circuits. In general it is not necessary or helpful to leave a valve on test for a considerably longer period than is necessary to complete the test in question.

Finally it must be stressed that whilst every care has been taken in the compilation of this publication and the 'AVO' Valve Data Manual, to ensure that all data given is correct as far as is known at the time of going to press, it is not impossible that with the many thousands of figures involved, errors will have crept in. The manufacturers' cannot hold themselves responsible for any damage that might occur to a valve or to the instrument from such a cause.

For convenience, we give below an abbreviated list of instructions but before switching ON the full operating instructions should be read and always be used for reference when testing unusual types of valves.

- (1) Check mains adjustment tap and connect mains lead to supply.
- (2) Set CIRCUIT SELECTOR to CHECK (C) and ELECTRODE SELECTOR to a'.
- (3) Set HEATER VOLTS to value indicated in Valve Data.
- (4) Set GRID, SCREEN and ANODE VOLTS to values indicated in Valve Data.
- (5) Set VALVE PIN SELECTOR switch as indicated in Valve Data and ensure that the links are tight.
- (6) With LEAKAGE switch set to \sim , switch on and adjust pointer to position by means of SET \sim switch.

ALL VALVES

- (1) Insert valve and make any top cap connections if required.
- (2) Fully rotate LEAKAGE switch. Check heater continuity at h(C) and insulation on all other positions.
- (3) Set CIRCUIT SELECTOR to CHECK (H) to measure leakage with valve hot.
- (4) Set CIRCUIT SELECTOR to c/h INS to measure leakage between heater and cathode with the valve hot. (If valve is indirectly heated.)

TRIODES, DOUBLE TRIODES, DOUBLE TRIODE PENTODES, DOUBLE PENTODES, DIODE PENTODES, AND TETRODES IN SIMILAR COMBINATION.

ANODE CURRENT. Set ELECTRODE SELECTOR to a' and CIRCUIT SELECTOR to TEST. The mA meter should then indicate 'Anode Current'. Reduce mA switch setting if required. NOTE: if the blue OVERLOAD lamp is illuminated, switch off and check for incorrect setting of VALVE PIN SELECTOR switch or panel controls. If all controls are correct and lamp continues to light when instrument is switched on again, the valve is probably soft and the test should be discontinued.

MUTUAL CONDUCTANCE

With all controls set as for anode current measurement, the mutual conductance will be indicated on the special mA/V meter. To use the comparison scale, set the Nominal mA/V calibrated scale to the mutual conductance figure given in the Valve Data. If the measured mutual conductance is less than 50% of this figure the meter pointer will lie in the red portion of the scale and a reject valve will be indicated.

For multiple valves check data if different for other sections. Set the CIRCUIT SELECTOR switch back to c/h INS and set up appropriate voltages for the next section. Set the ELECTRODE SELECTOR to a'' and then repeat for a''' if applicable.

GAS TEST

To measure grid current set CIRCUIT SELECTOR to position GAS. Meter will now indicate gas current, full scale indication being 100 μ A.

DIODES

To check diodes turn the ELECTRODE SELECTOR to a_d' and mA switch to 1mA on D/R scale (unless otherwise indicated in Valve Data). Turn CIRCUIT SELECTOR to TEST. The condition of the valve will now be given on the REPLACE/GOOD scale of the meter. For multiple diodes check as required at a_d'', a_d''' and a_d'''' positions of the ELECTRODE SELECTOR.

RECTIFIERS

To check rectifiers, set ELECTRODE SELECTOR to a_d' and set anode loading given in Valve Data on D/R section of the mA switch. Turn CIRCUIT SELECTOR to TEST. The condition of the valve will now be indicated on REPLACE/GOOD scale of the mA meter. Load reading is per anode. Check full wave rectifiers at position a_d' and a_d'' of ELECTRODE SELECTOR switch.

At the completion of tests all switches should be set to their lowest value.

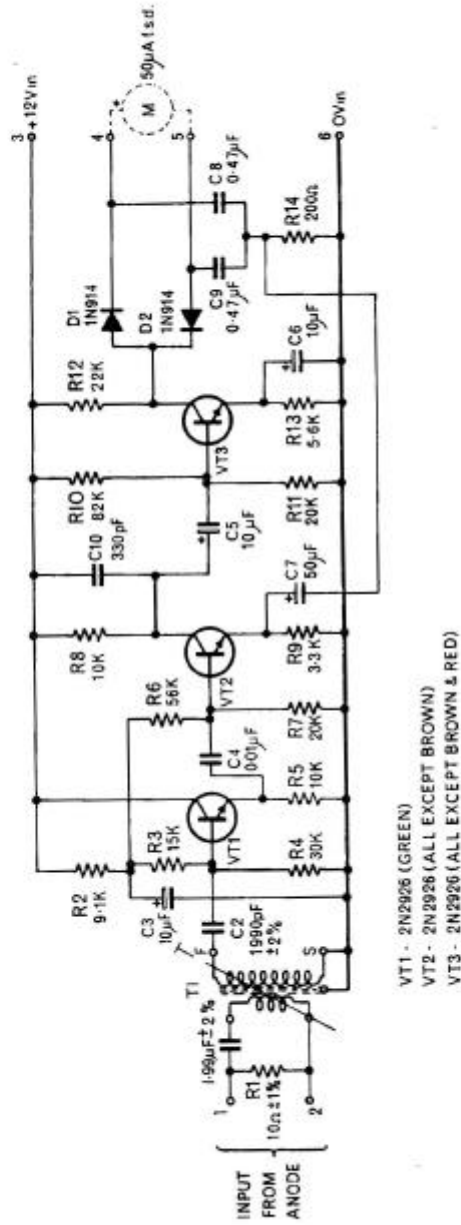

AMPLIFIER CIRCUIT DIAGRAM

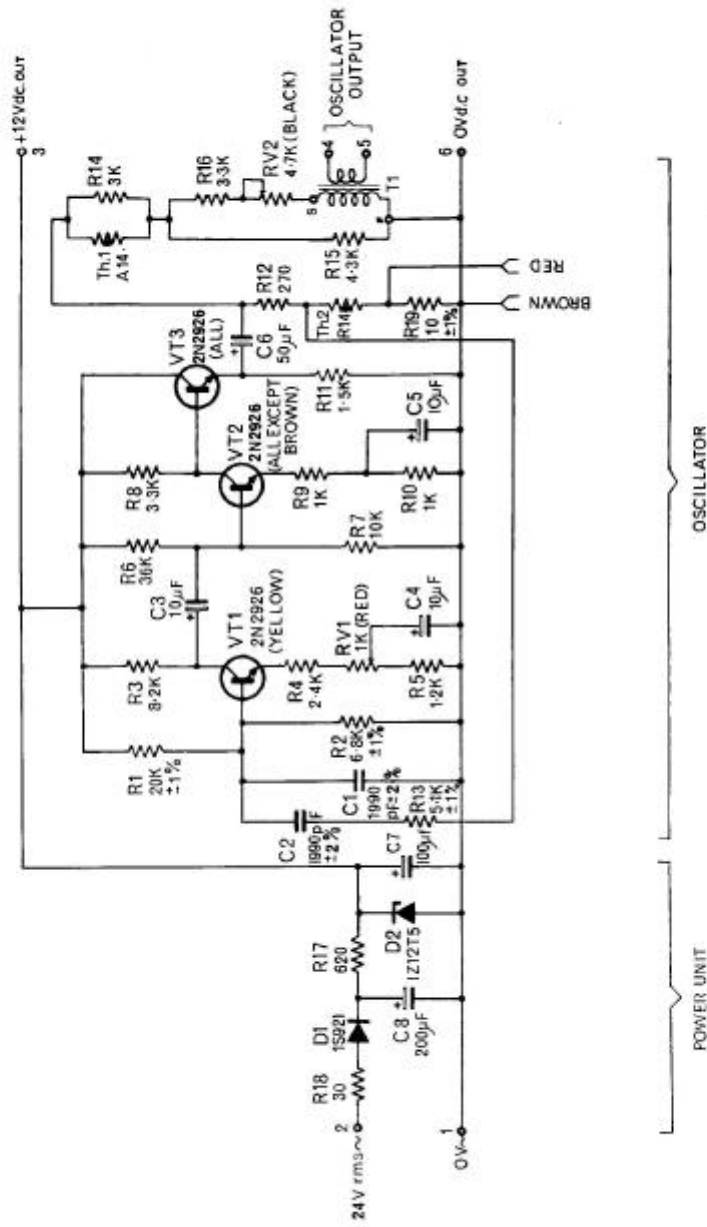

OSCILLATOR AND POWER UNIT CIRCUIT DIAGRAM

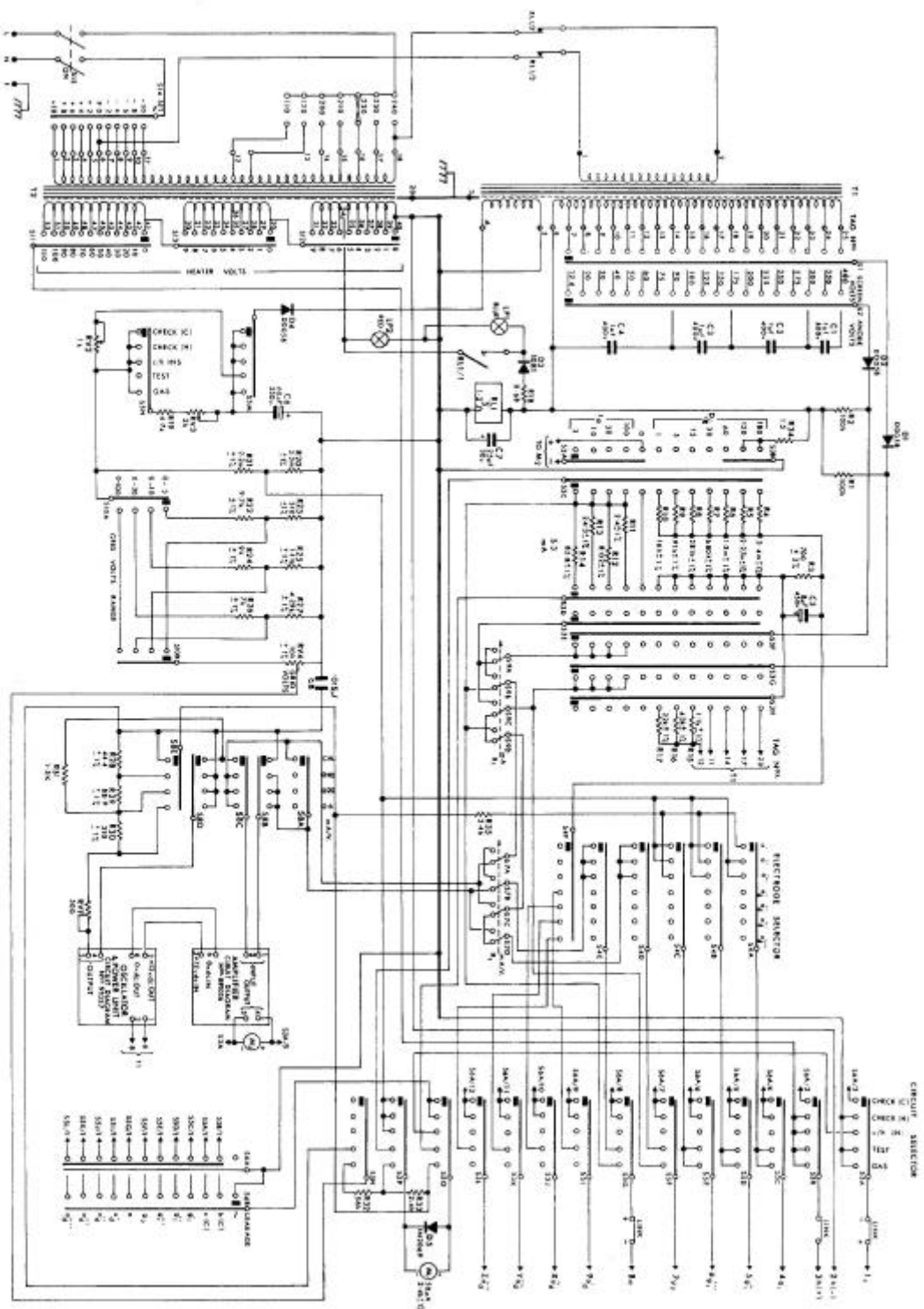

INSTRUMENT CIRCUIT DIAGRAM Figure 6