

- (h) Press down the spring-loaded button in the aerial terminal on the transmitter unit, and insert one side of the dipole feeder wire. The other side of the dipole feeder wire should be inserted into the earthing hole near the aerial tuning meter of the transmitter unit.

The counterpoise is not used with the horizontal dipole.

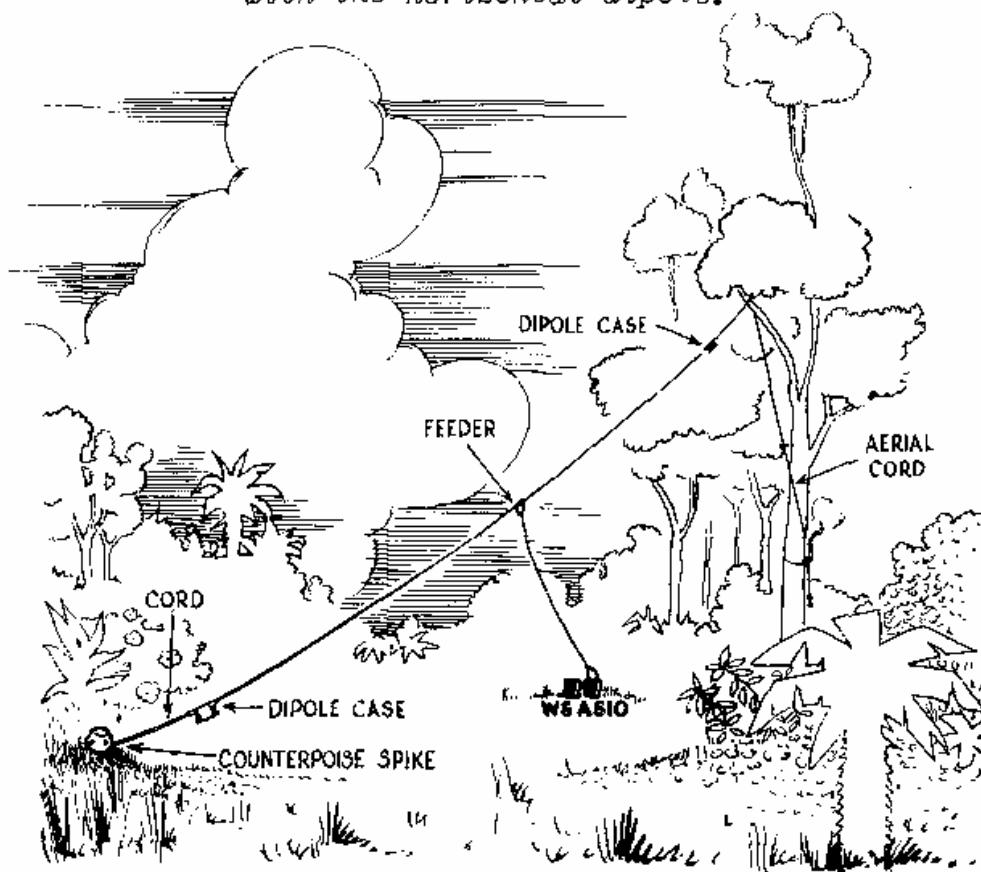
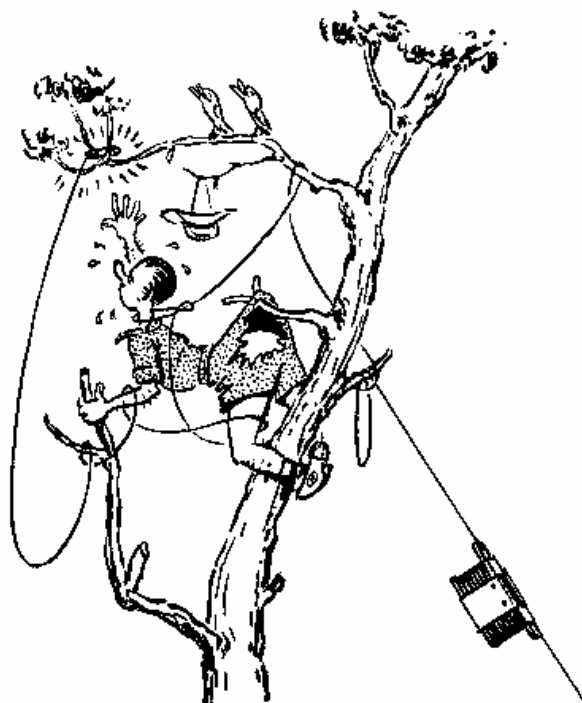

FIG. 25 - INCLINED DIPOLE ERECTED

- (j) If setting up an inclined aerial, make sure that the dipole case at the lower end is not making contact with the ground. Use the counterpoise spike to secure the lower end by attaching a cord from it to the dipole case as shown in Fig. 25 but do NOT spread out counterpoise wires.

When closing down the station and winding the aerial wires back on their spools, be sure to wind the wires *SIDE BY SIDE*. *THIS IS MOST IMPORTANT.*



When dismantling station, lower the aerial, disconnect the cord, then pull the cord from the bobbin end. — — — —
DON'T ATTEMPT TO THROW THE BOBBIN BACK OVER THE TREE AS THIS OPERATOR DID!

CHAPTER THREE — OPERATION

SECTION 12 — PRELIMINARY.

Action on receipt of station.

66. When a station is received, it should be checked to make certain that it contains all the items shown in Complete Equipment Schedule No.1636.

Report any deficiencies at once.

67. The equipment should function properly as soon as it has been correctly set up. If it does not respond to the operating instructions laid down in this chapter, the fact should be reported at once, so that action to repair or replace it may be taken without losing time.

Crystals.

68. Lift the transmitter carrying handle and unscrew the crystal cover. Plug crystals of the required frequencies into the sockets in the transmitter unit. In the spaces provided on the crystal

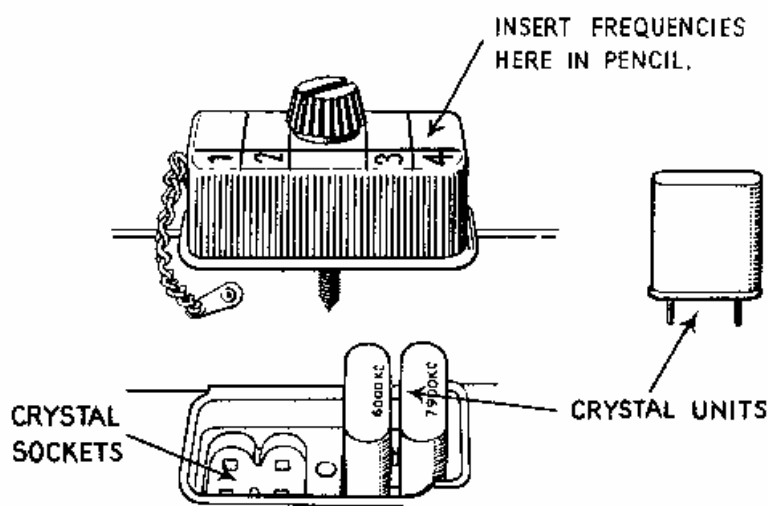
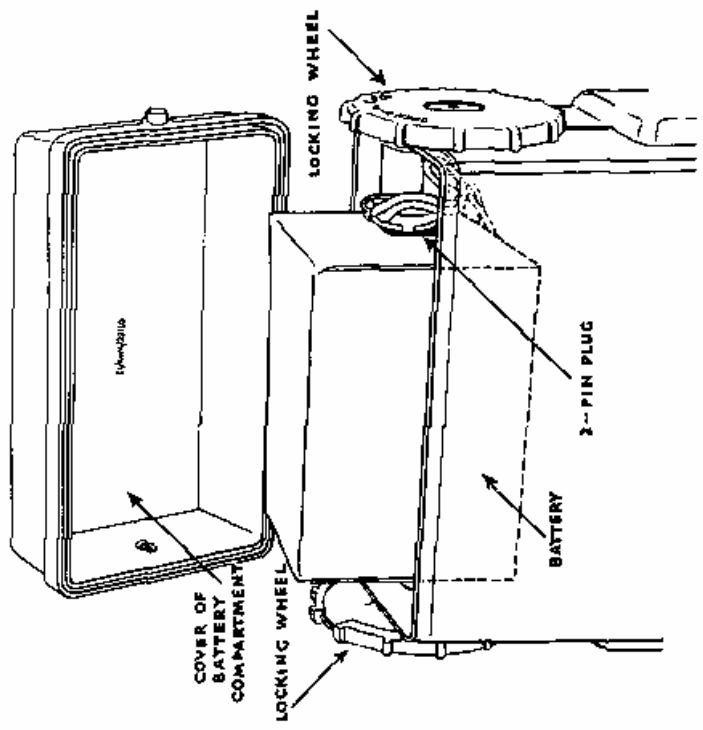
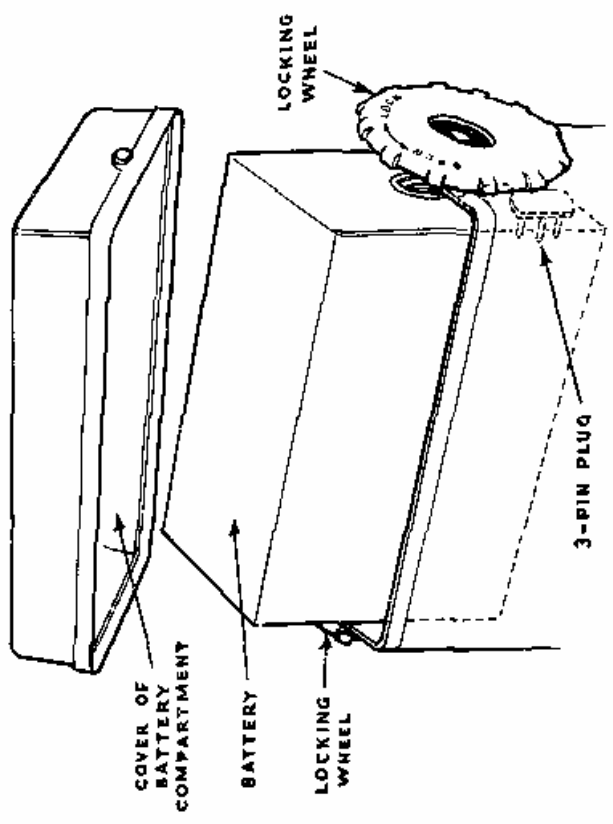

FIG. 26 - CRYSTAL UNITS AND COVER

cover, mark up in pencil the frequencies of the crystals inserted in sockets 1, 2, 3, and 4. (These frequencies are stamped on the crystal cases, usually



LT BATTERY FITTED IN RECEIVER



HT BATTERY FITTED IN TRANSMITTER

FIG. 27 - FITTING OF BATTERIES

in kilocycles, e.g., 7490. It is possible that they may be marked in megacycles, e.g., 7.490). Replace the cover, ensuring correct seating, and screw down firmly.

Fitting batteries. (See Fig.27)

69. Turn the set units over and rotate the locking wheels in the direction indicated thereon to unlock the battery compartments. Remove the covers. Connect the batteries to the set by means of the plugs provided, and fit the batteries firmly into the compartments - LT (the smaller battery) in receiver, HT bias in transmitter. Replace the covers and lock the compartments.

Testing batteries. (See Fig. 28)

70. Screw the transmitter and receiver inter-connecting plug and socket (1) firmly together. Set A-B-NET switch (2) to "NET".

LT battery : Set function switch (3) to "CW". The aerial tuning meter (4) in the transmitter should read within the red band on the "AER. TUNE" scale.

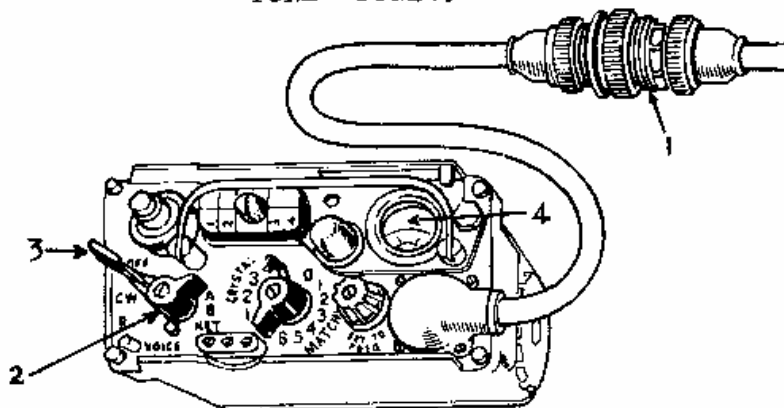

FIG.28 - TESTING BATTERIES

HT battery : Hold function switch (3) on "VOICE". The aerial tuning meter (4) in the transmitter should read within the red band on the "AER. TUNE" scale.

Switch off by setting function switch (3) to "OFF".

SECTION 13 — SETTING UP STATION.

71. Turn to Figs. 30, 31, and 32 which illustrate the method of setting up the rod aerial, end-fed aerial, and dipole aerial stations respectively. The procedure is common to all stations. It does not include details of aerial erection which are fully described in Chapter Two, and are necessary preliminaries to the setting up procedure.

SECTION 14 — NETTING.

72. It does not matter how good the wireless set you are using may be, you will not have good signals on a group of stations unless they are all accurately tuned to the same ordered frequency. This is called "NETTING", a very important operation *which must be thoroughly understood by all operators.*

73. With the WS A510, netting is obtained independently of other stations by tuning the receiver to zero beat against its own transmitter crystal. When the transmitter has been tuned to a given frequency, a whistle will be heard in the earphones if the receiver is netted to the same frequency. This whistle must be brought to "Silent Point" or

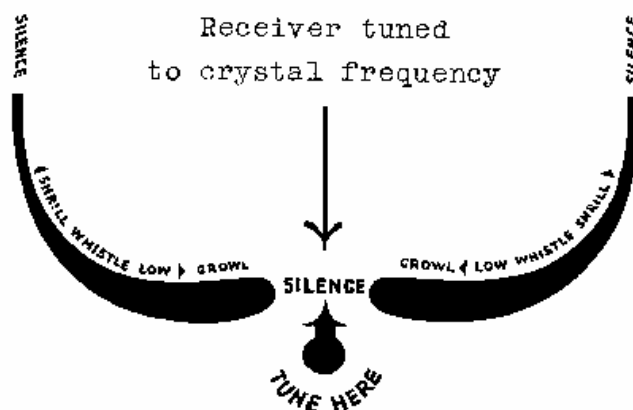

FIG. 29 - FINDING THE SILENT POINT

"Zero Beat" so that signals from the distant station can be heard when the function switch is turned to "R". "Silent Point" (or "Zero Beat") is depicted in Fig. 29, and the sequence of tuning and netting operations is shown in Figs. 30, 31 and 32 for rod aerial, end-fed aerial, and dipole aerial stations respectively.

IMPORTANT

Check netting at frequent intervals as various conditions such as the heat of the day or state of your batteries can cause the frequency to vary slightly, enough to put you off net. A check at intervals of approximately 15 minutes is recommended.

"Ghost" signals.

74. The A510 wireless set is known to produce "ghost" signals. These are spurious signals, that is, echoes of the true signal.

75. It is important to be able to recognize ghosts when you encounter them because *if you net to a ghost you will not receive the distant station.* The ghosts are **not** so strong as the genuine signal, and usually have background noise, whereas the true signal has none.

76. With new batteries such ghosts will only be heard at twice the operating frequency.

Example : Your operating frequency is 2020 Kc/s. Your ghost will be heard on 4040 Kc/s on the low (blue) band.



77. When your batteries have been in use for some hours you will hear a weak ghost at approximately 2050 Kc/s, and other weak ghosts throughout the band.

Learn the characteristics of your set, and "lay" the ghosts by ascertaining at what positions on the receiver dial the ghosts of each crystal may be found.

SECTION 15 — OPERATING INSTRUCTIONS.

78. The methods of tuning and operating the rod aerial, end-fed aerial, and dipole aerial stations are shown pictorially in Figs. 30, 31, and 32 respectively. The procedures are very simple, and operators will quickly learn how to use their sets to the best advantage. The following points should be remembered.

Rod aerial station. (2 to 10 Mc/s)

- (a) Always use the transmitter "A-B-NET" switch in the "B" position.

End-fed aerial station. (2 to 10 Mc/s)

- (b) The transmitter "A-B-NET" switch can be used in either "A" or "B" position depending on which table on the aerial bobbin is used. Use table "A" with the switch at "A" whenever possible.
- (c) The counterpoise should be used, and its four black wires spread out on the ground. The green wire goes to the transmitter earth terminal.

Dipole aerial station. (3.3 to 10 Mc/s)

- (d) Always use the transmitter "A-B-NET" switch in the "B" position.
- (e) No counterpoise is used with the horizontal dipole aerial.
- (f) When using the inclined dipole, use the counterpoise spike to hold the cord connection to the lower dipole bobbin to the ground. Do not spread out the counterpoise wires, keep them all wrapped around the spike.

OPERATION OF WIRELESS STATION AS10 WITH ROD AERIAL

SETTING UP RECEIVER AS10 AND TRANSMITTER AS10

- 1 INTERCONNECTING PLUG AND SOCKET, join, and screw firmly together.
- 2 HANDLE - HANDLE and TUNING. Plug either or both in sockets.
- 3 TRANSMITTER - CRYSTAL SELECTOR SWITCH. Select crystal of desired frequency by turning to number corresponding with number and frequency shown on cover for crystal units.
- 4 TRANSMITTER - FREQUENCY CONTROL. Turn to set transmitter to ordered frequency.
- 5 RECEIVER - FREQUENCY BAND SWITCH. Set to appropriate band - BLUE - 2-4.5 Mc/s. ORANGE-4.5 to 1.0 Mc/s.

FREQUENCY RANGE 2-10 Mc/s.

TUNING TRANSMITTER AS10

- 6 MARCHING SWITCH - Set to "0".
- 7 A-B-KEY SWITCH - Turn to "B".
- 8 FUNCTION SWITCH - Hold on "VDIOP".
- 9 ROD TUNING KNOB - Adjust to give max. reading in serial tuning meter.
- 10 ADD NUMBER LOCKING SWITCH - Turn clockwise to lock tuning knob on rod tuner.
- 11 FUNCTION SWITCH - Allow to return to "P".

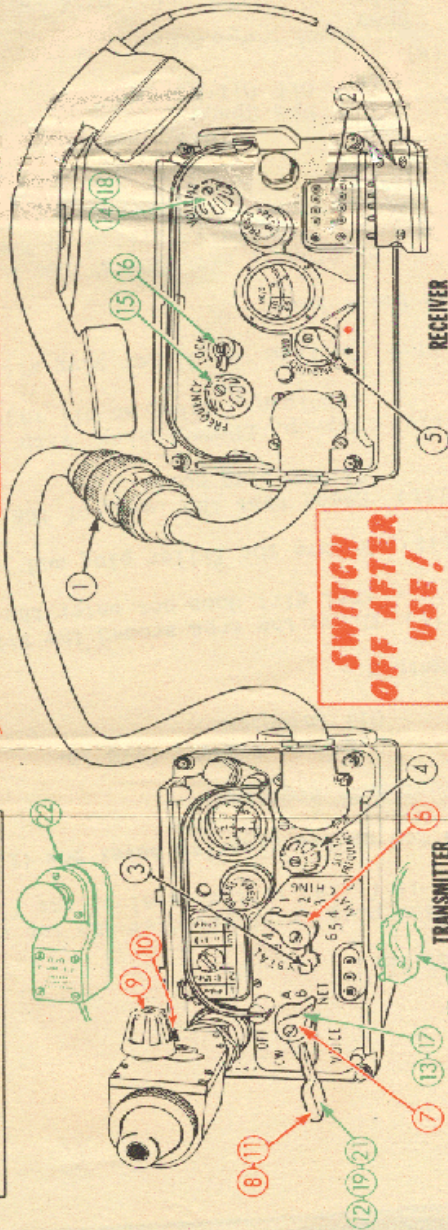
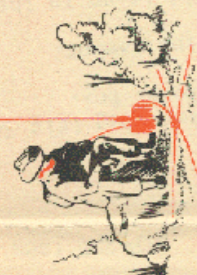
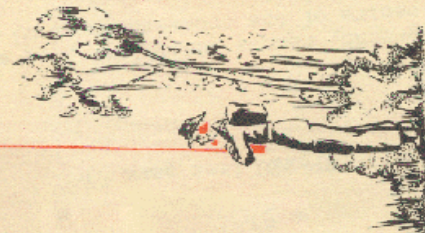

As frequencies of 2-10 Mc/s. band, prescribed method of tuning does not necessarily give best results. Where operation at these frequencies is necessary it is preferable that timing operations be given an actual check with base before stations are sent out on patrol.

Operations 12 to 18 should be repeated intervals of approximately 15 minutes to check setting. Various conditions such as the heat of the day or state of your batteries may cause the frequency to vary slightly, enough to put the set off key.

NOTE

FIG. 30

VOICE OPERATION

- 12 TRANSMITTER - FUNCTION SWITCH. Turn to "P".
- 13 TRANSMITTER - A-B-KEY SWITCH. Turn to "B".
- 14 RECEIVER - VOLUME CONTROL KNOB. Turn fully clockwise (UP).
- 15 RECEIVER - FREQUENCY CONTROL KNOB. Turn CAREFULLY about required frequency on dial scale until whistle is heard. Refer to "ZERO BEAT" or "Silent Point" on in diagram below.

Receiver tuned to crystal frequency
- 16 RECEIVER - FREQUENCY LOCK. Turn anti-clockwise CAREFULLY without altering tuning point.
- 17 TRANSMITTER - A-B-KEY SWITCH. Turn to "P".
- 18 RECEIVER - VOLUME CONTROL KNOB. Adjust for comfort of hearing.
- 19 TRANSMITTER - FUNCTION SWITCH. Hold on "VOICE". Speak in normal voice, DO NOT SCOUT. If using handset, press pressure switch.

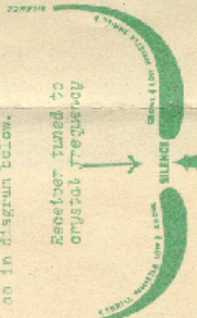

C.W. OPERATION

- 20 TRANSMITTER - PLUG FOR KEY. Plug in and proceed as for "VOICE" operations 12 to 19. Until key is plugged in distant station will not be heard.
- 21 TRANSMITTER - FUNCTION SWITCH. Turn to "CW".
- 22 TRANSMITTER - KEY. Send.
- 23 TRANSMITTER - PLUG FOR KEY. Remove before returning to "VOICE" operation.