

7610-010-0284

RESTRICTED

THE INFORMATION GIVEN IN THIS DOCUMENT IS NOT TO BE
COMMUNICATED EITHER DIRECTLY OR INDIRECTLY TO THE
PRESS OR TO ANY PERSON NOT AUTHORIZED TO RECEIVE IT



AUSTRALIAN MILITARY FORCES



USER HANDBOOK, A510 WIRELESS STATION

1956

MILITARY BOARD

Army Headquarters.
Melbourne.

1 Apr. 56

Issued by Command of the Military Board.

W. M. Knight

7610-010-0284

RESTRICTED

THE INFORMATION GIVEN IN THIS DOCUMENT IS NOT TO BE
COMMUNICATED EITHER DIRECTLY OR INDIRECTLY TO THE
PRESS OR TO ANY PERSON NOT AUTHORIZED TO RECEIVE IT



AUSTRALIAN MILITARY FORCES



USER HANDBOOK, A510 WIRELESS STATION

1956

Serial No.	AAO's	AMENDMENTS

SYNOPSIS

The A510 wireless set is a lightweight, man-pack transmitter-receiver for operation principally by long range infantry patrols. It functions in the high frequency band from 2 to 10 megacycles per second, and has facilities for either "VOICE" or "CW" working. The operator can set up four crystal controlled channels within this band, and select the required frequency by means of a switch on the panel of the transmitter unit. The transmitter-receiver operates from two dry batteries, $1\frac{1}{2}$ volts, and $90/-7\frac{1}{2}$ volts. The set units are hermetically sealed, and are normally carried in special pouches attached to the web equipment.

Complete Equipment Schedule No. 1636 is the only authorised list of components for the Wireless Station A510. This User Handbook should not be quoted when submitting demands on Ordnance.

CONTENTS

	Para.
CHAPTER ONE - GENERAL DESCRIPTION	
Section 1 - Purpose and facilities ..	1-3
2 - Working ranges and aeriaks ..	4-6
3 - Power supply and consumption ..	7-10
4 - General description ..	11-20
5 - Accessories -	
Headgear assembly and handset - general ..	21-24
Microphone and receiver headgear assembly ..	25-27
Telephones, hand ..	28
Keys, telegraph, lightweight ..	29-31
Cases, spares, A510 ..	32
6 - Transit and carrying equipment ..	33-37
7 - Weights and dimensions ..	38
CHAPTER TWO - AERIALS AND COMMUNICATION DETAILS	
Section 8 - General ..	39-43
9 - The rod aerial ..	44-51
10 - The end-fed aerial and accessories ..	52-58
11 - The dipole aerial and accessories ..	59-65
CHAPTER THREE - OPERATION	
Section 12 - Preliminary ..	66-70
13 - Setting up station ..	71
14 - Netting ..	72-77
15 - Operating instructions ..	78
CHAPTER FOUR - USER MAINTENANCE	
Section 16 - General ..	79-81
17 - Replacement of faulty pilot lamps ..	82
18 - Removal of receiver and microphone insets for inspection ..	83-87
19 - Fault location ..	88

NOTES

TABLES

	Page
TABLE 1 - Wireless Station A510 - Weights and Dimensions	21
TABLE 2 - Fault finding chart	60

ILLUSTRATIONS

Fig.	Page
- Frontispiece	(vi)
1. Man-pack station	1
2. Transmitter, A510 and Receiver, A510 ..	3
3. HT battery housing	4
4. Receiver, A510 - Controls	6
5. Transmitter, A510 - Controls	8
6. Inserting wire aerial lead	9
7. Inserting green earth lead from counter- poise or lead from dipole feeder ..	11
8. Microphone and receiver headgear assemblies, SI, lightweight	13
9. Telephones, hand, SI, No.4A (Aust.) ..	15
10. Keys, telegraph, lightweight, (Aust.), No.1	16
11. Cases, spares, A510	17
12. Cases, transit, A510	18
13. Webbing carrying equipment, A510 ..	19
14. Lay-out of complete A510 station ..	20
15. Rod aerial ground station	24
16. The rod tuner	27
17. Aerials, flexible, 8-ft.(Aust.), assembly by use of nylon cord	28
18. Extension of rod aerial	30
19. End-fed aerial components	32
20. Composition of end-fed aerial	34
21. End-fed aerial erected	35
22. Dipole aerial components	38
23. Dipole aerial set up between masts ..	40
24. Dipole feeder arrangement	40
25. Inclined dipole erected	41
26. Crystal units and cover	43
27. Fitting of HT and LT batteries	44
28. Testing batteries	45
29. Finding the silent point	46
30. Operation of WS A510 with rod aerial ..	49
31. Operation of WS A510 with end-fed aerial	51
32. Operation of WS A510 with dipole aerial	53
33. Replacement of pilot lamp	56
34. Removal of receiver insets	58



frontispiece

RESTRICTED

USER HANDBOOK, A510 WIRELESS STATION

CHAPTER ONE—GENERAL DESCRIPTION

SECTION 1 — PURPOSE AND FACILITIES.

1. The A510 wireless set is a crystal controlled, low power, lightweight transmitter-receiver, designed primarily for use by long range infantry patrols. It can be used as a man-pack station on the move, in a vehicle, or as a ground station. For the ground station role, improved aerial systems are provided to achieve greater range.

2. Operation can be either "VOICE" or "CW" in the frequency range 2 to 10 megacycles per second (Mc/s).

3. The set is carried in two special pouches on the standard webbing equipment in place of the basic pouches. Fig. 1 shows one method of carrying the equipment when operating on foot. Other, perhaps



FIG. 1 - MAN-PACK STATION.

more convenient, methods will no doubt be discovered by operators as they become more accustomed to the equipment. For example, one webbing shoulder strap may be used to carry, in sling fashion, the transmitter at one end, and the receiver at the other.

SECTION 2 — WORKING RANGES AND AERIALS.

4. Communication distances are governed by the aerial system used. With a mar-pack station, using a rod aerial, the maximum range would be about 2 miles for "VOICE" and 4 miles for "CW". With a horizontal dipole system on sky wave operation, a "CW" range of 120 miles may be achieved.

5. The power available for transmission is restricted by the necessity for reducing weight to a minimum. To use this power as effectively as possible, the following aerials are supplied with each complete station :-

Aerials, flexible, 8-ft. (Aust.) ~ (rod aerial)
- 2 (one spare)

Aerials, end-fed, adjustable, 135-ft. ~ (wire
aerial) - 1

Aerials, lightweight, 68-ft. - (dipole wire
aerial) - 2 (per dipole
aerial).

6. Detailed descriptions, working ranges, and methods of erection are given in Chapter Two.

SECTION 3 — POWER SUPPLY AND CONSUMPTION.

7. Power is obtained from two dry batteries; the LT battery ($1\frac{1}{2}$ volts), and the HT battery (90 volts). The LT battery, carried in a separate sealed compartment in the bottom of the receiver unit, is used by both the transmitter and the receiver. The HT battery incorporates a $7\frac{1}{2}$ volts bias battery, and is carried in the transmitter unit in the same manner as the LT battery. The HT bias battery is also used by both units.

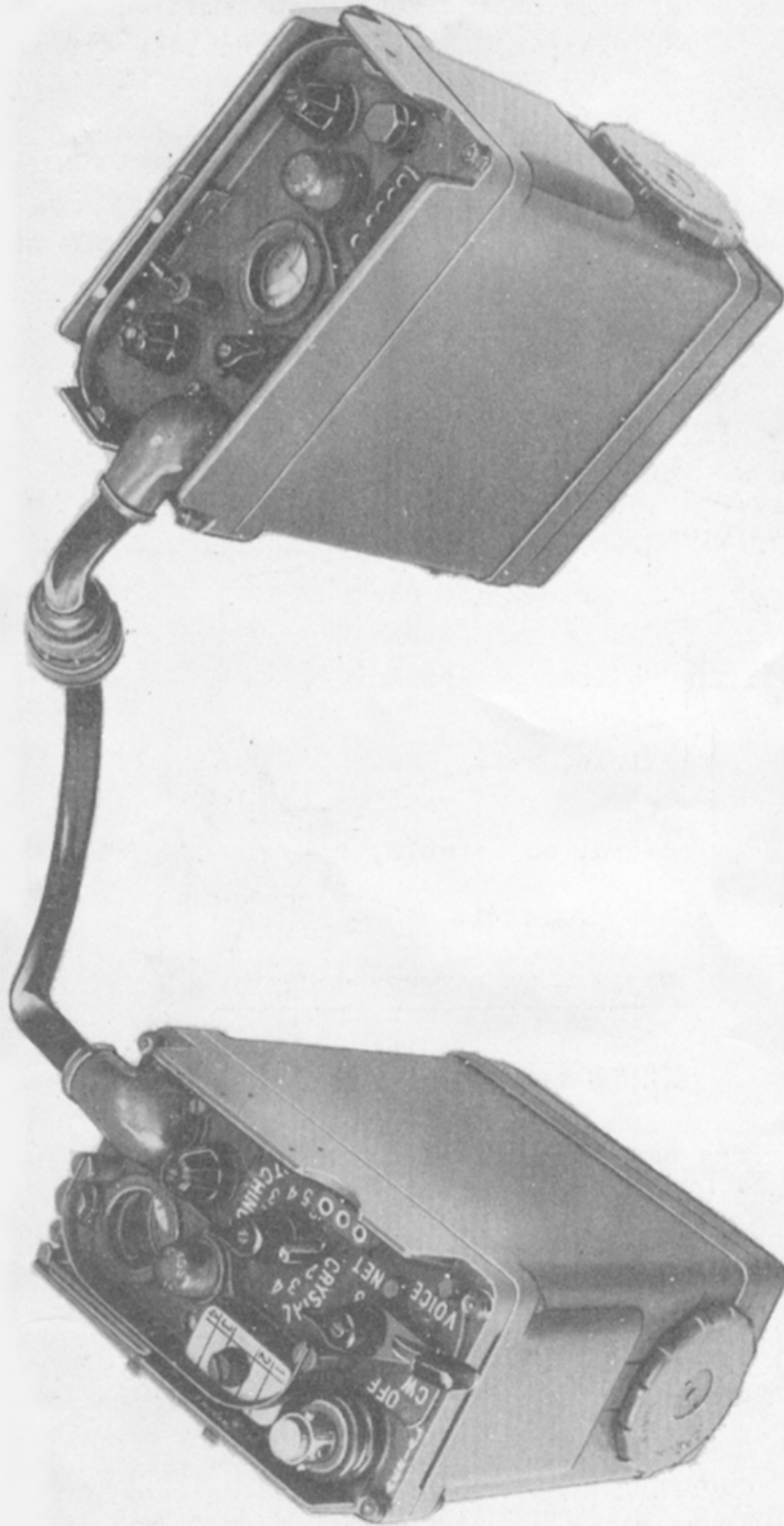

FIG. 2.
TRANSMITTER, A510 AND RECEIVER, A510

8. The power output is approximately 0.15 watts for "VOICE" (unmodulated), and 0.5 watts for "CW".

9. The normal life of the batteries is approximately 14 hours for continuous operation with a ratio of 1 minute send/5 minutes receive.

10. These batteries are not issued from Ordnance with the station but will be maintained separately, and drawn from stores as required. *THEY MUST NOT BE STORED IN WS A510 TRANSIT CASES.*

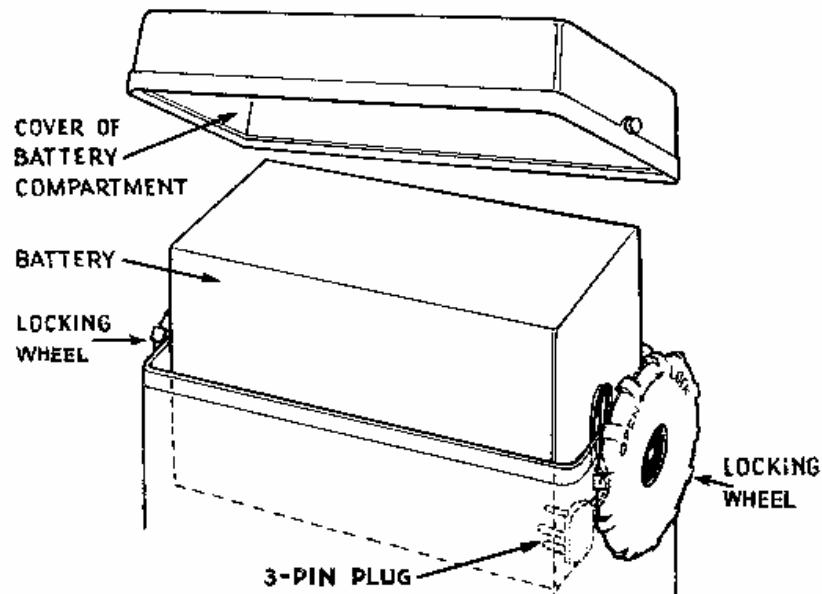

FIG. 3 - RT BATTERY HOUSING

SECTION 4 - GENERAL DESCRIPTION.

11. The set consists of two units, a transmitter and a receiver, each housed in a light, cast aluminum alloy case. Both units are hermetically sealed, and must not be opened by unqualified persons. For ease of replacement without breaking the main seals, the dial illumination lamps, crystals, and batteries are all in separate, sealed compartments, readily accessible without the use of tools.

12. Carrying handles are provided on each unit for ease of handling.

13. The transmitter, carried on the left, and

the receiver on the right of the man, appear to be separate units, but are inter-dependent in operation. Neither will operate until the inter-connecting plug and socket are securely joined.

Receiver. (Fig.4)

14. The receiver is a conventional 5 valve, reflexed super-heterodyne, with one stage of tuned RF amplification, having the sensitivity of a high grade communication receiver. There is sufficient power output available from the receiver to drive two pairs of headsets in parallel.

15. Tuning is continuous over the frequency range 2 to 10 Mc/s in two bands, 2 to 4.5 Mc/s (blue scale), and 4.5 to 10 Mc/s (orange scale).

16. Netting is obtained independently of the distant station simply by tuning the receiver to zero beat against its own transmitter crystal.

17. Receiver controls, as marked on the panel (shown here in inverted commas and capitals), and other items on the receiver are explained below, and illustrated in Fig.4.

- (a) "FREQUENCY BAND". This switch selects the blue band (2 to 4.5 Mc/s), or the orange band (4.5 to 10 Mc/s). The colours are clearly marked, and correspond with the colours on the frequency dial scale. The switch has a wide arc of travel.
- (b) "FREQUENCY". This is the frequency control knob, the position of which can be fixed by rotating the "LOCK" lever anti-clockwise through 90 degrees. The frequency is indicated on the dial scale which is located in the centre of the panel. The dial scale shows the blue band (2 to 4.5 Mc/s), and the orange band (4.5 to 10 Mc/s).
- (c) "Humidity indicator". Immediately below the frequency dial scale is a humidity indicator which is normally a blue colour, but turns pink if moisture has leaked into the receiver, in which case the set should be

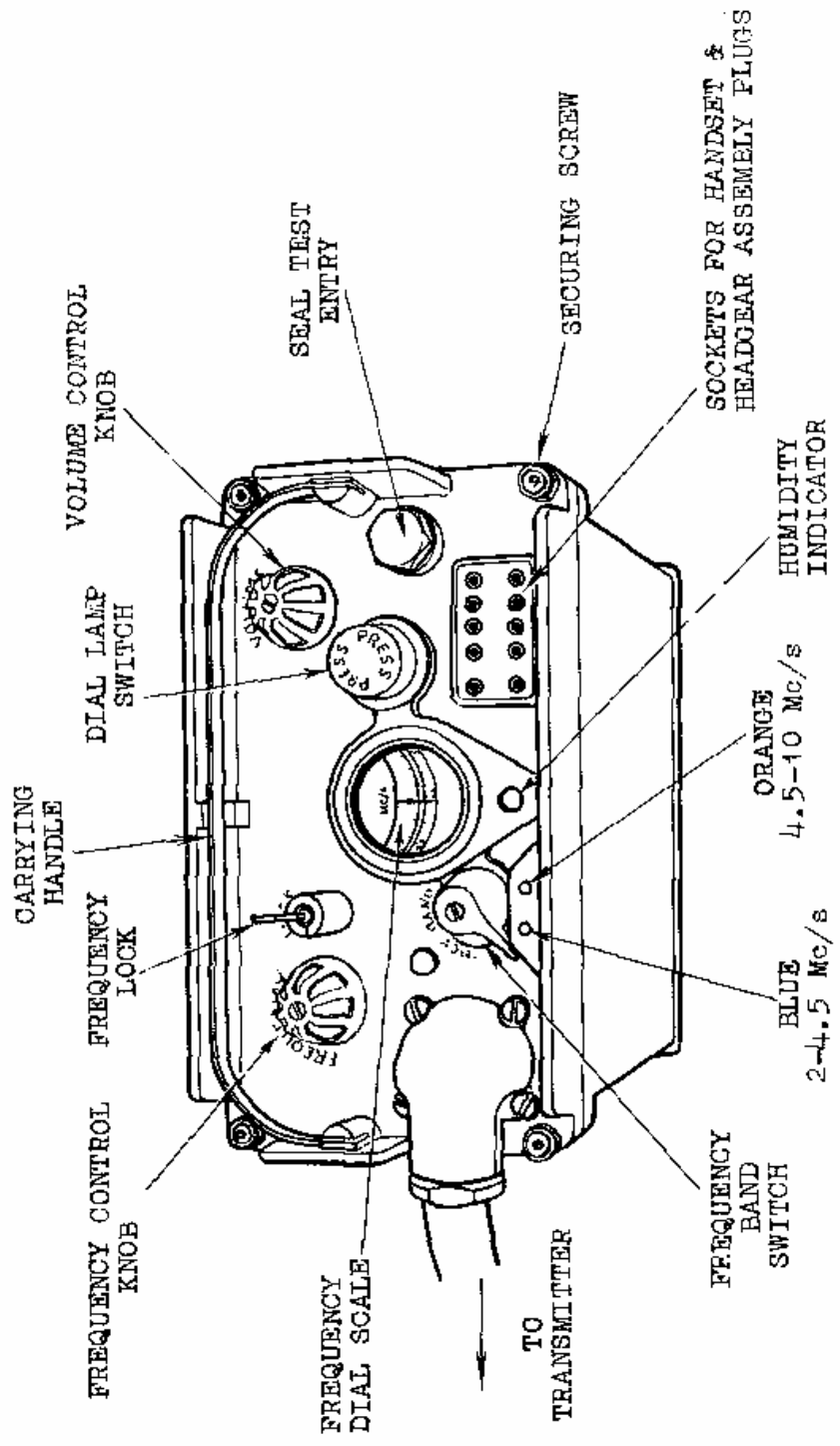

FIG. 4 - RECEIVER, A510 - CONTROLS

returned to base when possible.

- (d) Dial lamp switch. The rubber cap near the frequency dial scale covers a press-switch which, when pressed, actuates the pilot lamp when the function switch on the transmitter is set at "R".
- (e) "VOLUME". This control is situated in a corner of the panel opposite the frequency control knob. It increases or decreases the sound to the ear.
- (f) Five-pin sockets. These accept the handset or headgear assembly plugs, or one of each, as required.
- (g) Seal test entry. The hexagonal bolt on the right of the dial lamp switch seals the entry for leak testing (by R.Aust.Sigs. or RAEME personnel).

18. As previously mentioned, the LT battery is situated in the bottom compartment of the receiver unit. The battery is held firmly by a channel shaped holder, and two locking wheels secure the lid of the compartment. The battery connection is made by means of a 2-pin plug in the side of the battery.

Transmitter. (Fig.5)

19. The transmitter is a 4-valve, crystal oscillator-grid modulated, power amplifier transmitter. Its various features are described below; those shown in inverted commas and capitals are as marked on the panel:-

- (a) "AERIAL". The position of this terminal was chosen in order to keep the rod aerial as far away as possible from the operator's body when the set is carried on the man. The three radial pins at the top of the terminal form a polarized plug on which the bayonet type socket in the base of the aerial tuning inductor, or "rod tuner" as it is commonly called, (see para. 46) is mounted when a rod aerial is used. In the centre of this plug is a spring-loaded

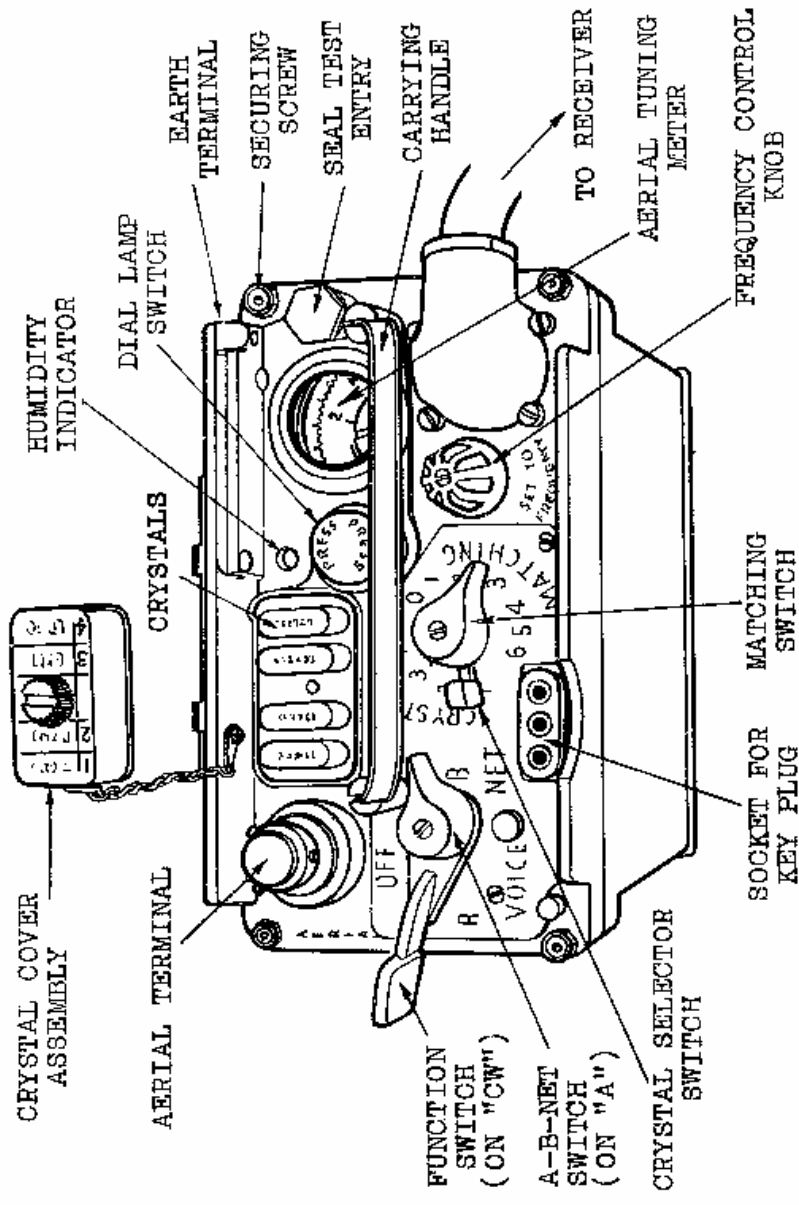

FIG. 5 - TRANSMITTER, A510 - CONTROLS

button which, when depressed, clears holes in the aerial terminal for insertion of dipole or end-fed aerial leads. (With these aeriels the rod tuner is not used.)

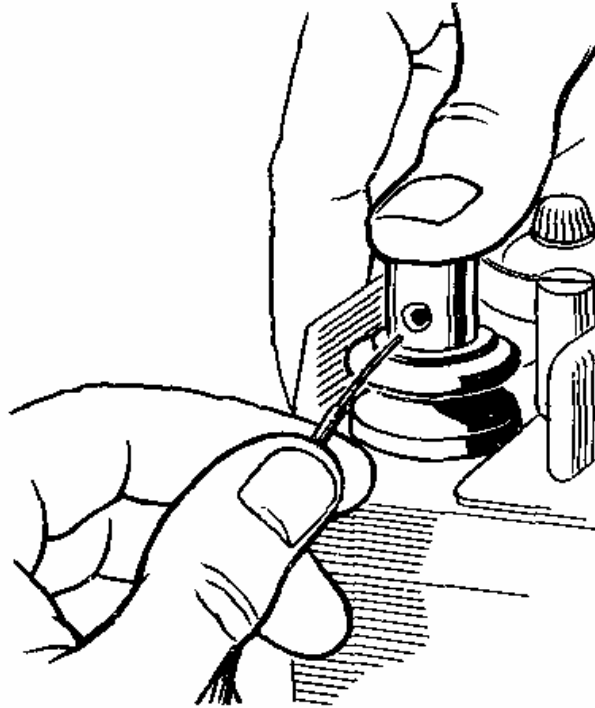

FIG.6 - INSERTING WIRE AERIAL LEAD

(b) "OFF-CW-R-VOICE". This function switch is operated by a lever knob. Once the station is on the air, complete control is exercised by manipulation of this lever knob. When switching from "R" to "VOICE", pressure on the knob must be maintained until speech is finished. Its strong return spring returns the lever knob to "R" when pressure is relaxed. The long lever used has the following advantages :-

- (i) Little force is required to operate it.
 - (ii) It projects from the side of the pouch so that it can be seen when the set is "on".
 - (iii) It is in a safe position when "off".
- The operating positions were chosen so that

- the lever, and therefore the operator's hand, are as far from the aerial terminal as possible on "VOICE". The lever should be pressed with the ball of the left thumb, the four fingers of the hand resting on the outside face of the case, well below the rod tuner.
- (c) "A-B-NET". This control is mounted on the same spindle as the function switch. The three positions are used for -
- "A" - Long wire end-fed aerial.
 - "B" - Long wire aerial, rod aerial, and dipole.
 - "NET" - To net receiver to transmitter.
- (d) Crystal sockets. To the right of the aerial terminal is the multiple socket for four miniature crystals. This is protected by an easily removed cover, and is itself sealed.
- (e) "CRYSTAL". This switch is mounted on the same spindle as the "MATCHING" switch, and selects the required crystal.
- (f) "MATCHING". This switch is used, in the main, only for long wire aeriails.
- (g) "SET TO FREQUENCY". This control sets the transmitter to the ordered frequency, and tunes the power amplifier.
- (h) Humidity indicator. } As for Receiver
- (j) Seal test entry. } [para. 17(c) and (g).]
- (k) Dial lamp switch. This is identical with the switch on the receiver but operates under different conditions. The switch functions when the transmitter function switch is on "CW" or "VOICE", and the "A-B-NET" switch is in any one of its three positions. To enable the transmitter to be tuned at night under conditions of wireless silence, the dial lamp switch will also function when the function switch is on "R" and the "A-B-NET" switch is on "NET".
- (l) Aerial tuning meter. The frequency dial scale, and meter scale (marked "AER. TUNE")

are seen through the one window, the frequency dial scale being off-set to enable the meter to be more easily read.

- (m) "EARTH" (Fig.7). On the outer flange near the aerial tuning meter is an earth terminal to which connection is made by *DEPRESSING* the leaf spring, inserting the earth wire through the counter-sunk hole in the outer flange, and then releasing the leaf spring.

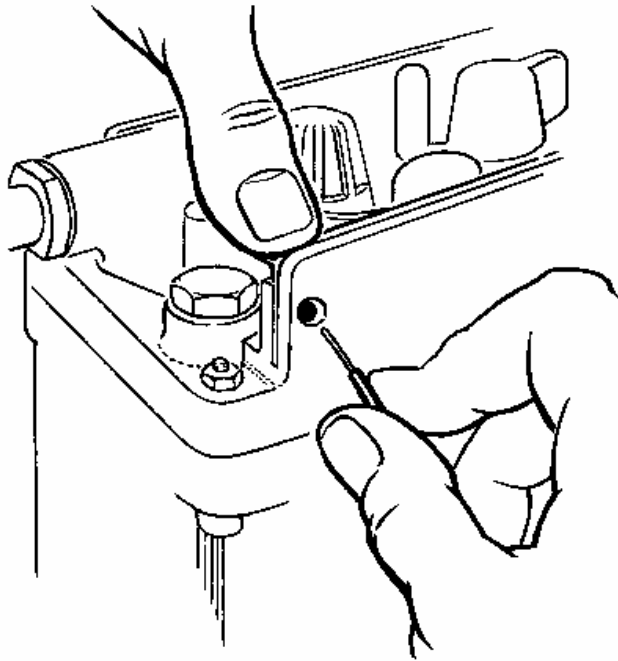

FIG.7 - INSERTING GREEN EARTH LEAD FROM COUNTERPOISE OR LEAD FROM DIPOLE FEEDER

20. The HT bias battery is housed in the sealed compartment in the bottom of the transmitter unit, in exactly the same manner as the LT battery is housed in the receiver, but connection is made by means of a 3-pin plug and socket.

SECTION 5 - ACCESSORIES.

Headgear assembly and handset - General.

21. These assemblies use new types of microphone and receiver insets which are hermetically sealed, and were developed specifically for Service use.

22. The microphone inset has a red body with a black stripe across its face to indicate a carbon microphone. (A white stripe would indicate an electro-magnetic microphone.)

23. The receiver inset has a green body with a white stripe across its face to indicate an electro-magnetic receiver.

24. The WS A510 is capable of working with either or both of these assemblies plugged in, and, in fact, two of either can be used at one time. Both assemblies are described in the following paragraphs. Microphone and receiver headgear assemblies, SI, lightweight.

25. The assembly comprises two ear pads holding the insets and horn, and is carried on the head by a head strap and neckband. There are two electro-magnetic receivers connected in parallel, and one carbon microphone, with a single drop lead terminating in a 5-pin plug on 6 feet of cord. The cord is of a new miniature design which should retain its flexibility under all but extremely cold conditions. The assembly generally is of robust construction, and will withstand a considerable amount of rough usage. When working "CW" the microphone horn may be removed from the assembly.

26. The parts of the headgear are described below :-

(a) Right ear pad. This is the major item of the assembly as it carries one receiver inset and the microphone inset, together with the microphone horn. It comprises a central portion housing the receiver, a shroud, and a cavity for the microphone. The shroud is designed to exclude only a limited amount of noise so that an officer does not have to shout instructions to an operator. It is designed to fold back off the lower part of the ear to allow circulation of air under hot or humid conditions.

(b) Cover plate. This is held in place by the

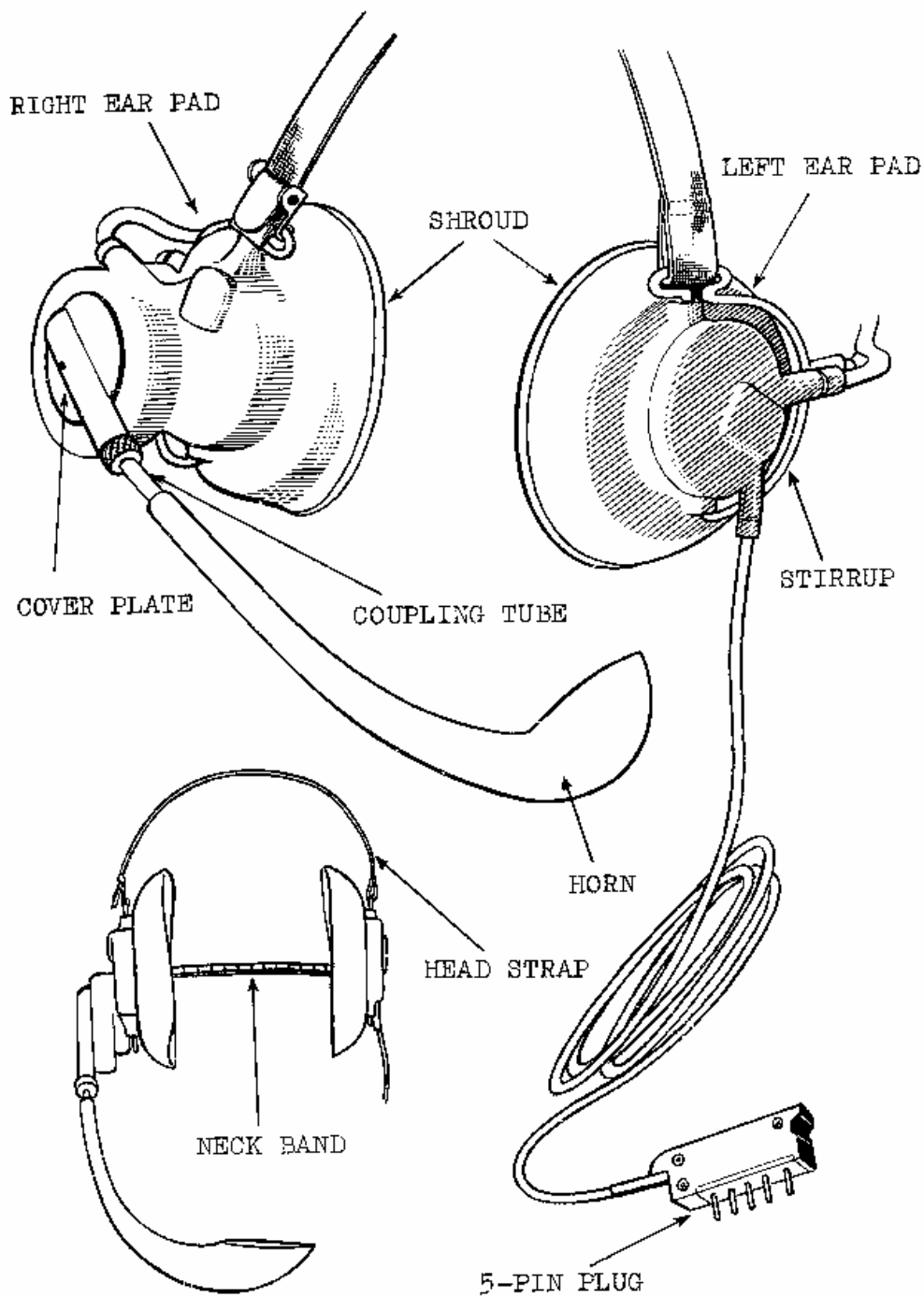

FIG. 8 - MICROPHONE AND RECEIVER HEADGEAR ASSEMBLIES,
SI, LIGHTWEIGHT

lip around the microphone cavity, and may be rotated to position the horn correctly. There is a small hole in the centre of the cover plate. This hole damps resonances from the horn, and must *NOT* be blocked.

- (c) Coupling tube. The bend in this tube may be used, by rotating the tube, to move the horn into or away from the centre of the mouth.
- (d) Horn. The horn is made of polythene, and can withstand considerable abuse - but do not jump on it! To adjust it to the correct position (centrally in front of the mouth, and just touching the lips) rotate, as necessary, the cover plate, the coupling tube, and the horn itself. It is also possible to slide the horn along the coupling tube for length adjustment.
- (e) Left ear pad. This carries the second receiver inset and a terminal plate. It has two cable entries; one accepts the cable from the right ear pad, and the other takes the connector for the assembly.
- (f) The stirrups. These couple the ear pads to the neck band and head strap.
- (g) Neck band. This spring steel band provides the necessary lateral pressure to hold the ear pads on the ears. The pressure may be adjusted by bending this band. *USE GENTLE PRESSURE WHEN BENDING.*
- (h) Head strap. This adjustable strap takes the full weight of the assembly.

Use of steel helmets with headset assembly.

27. When wearing a steel helmet over the headset assembly, the helmet strap is placed under the wire neck band.

Telephones, hand, SI, No. 4A (Aust.).

28. This handset has been designed as small as possible, consistent with variations in the sizes of human heads. It is the standard lightweight handset,

FIG. 9 - TELEPHONES, HAND, SI, NO. 4A (AUST.)

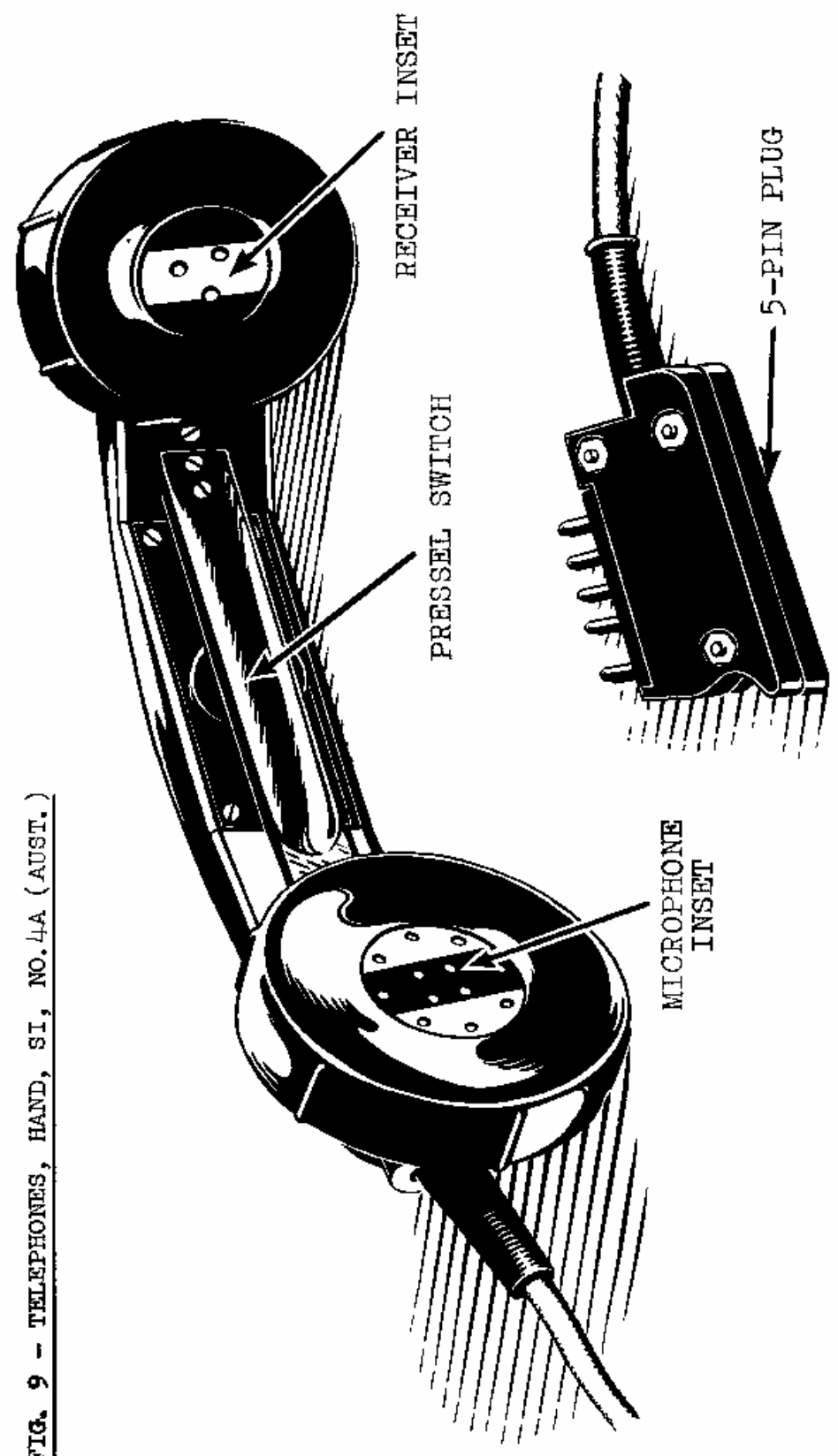

fitted with the same electro-magnetic receiver and carbon microphone as used on the headset described above. It has a pressel switch which *must be pressed while talking on the A510 wireless set.* This switch does not affect send/receive switching, and could be held pressed continuously. The handset is fitted with the same type of miniature cord and 5-pin plug as used on the headset assembly.

WARNING

If at any time you are tempted to remove the microphone or receiver insets of the headgear assembly or telephone handset, remember that this is BAD FOR THEM! Their connecting wires are very light and easily broken. If left alone both assemblies will give good service. Should it be necessary in emergency to remove the insets for inspection, refer to Chapter Four, paras. 84-87 for guidance.

Keys, telegraph, lightweight, (Aust.), No.1.

29. This key was designed as a lightweight, sealed item for use on all field wireless sets. It has fixed adjustments of 0.013 inch travel, and

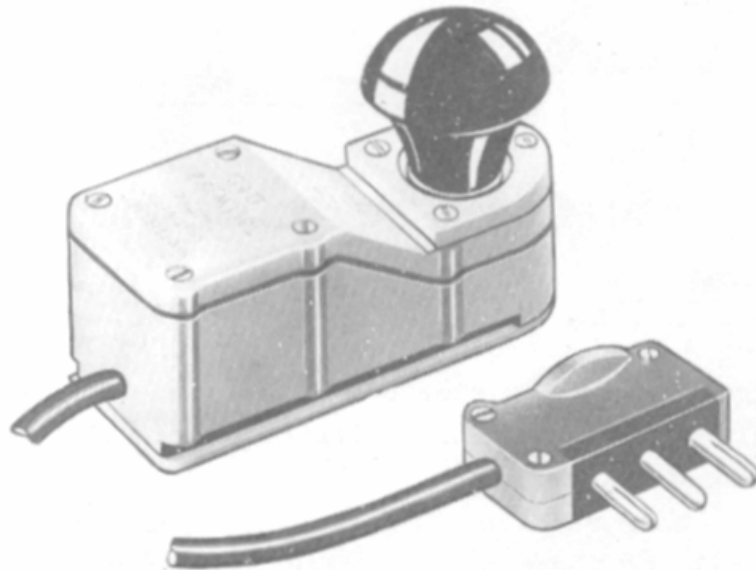

FIG.10

KEYS, TELEGRAPH, LIGHTWEIGHT, (AUST.), NO.1