



RESTRICTED

THE INFORMATION GIVEN IN THIS DOCUMENT IS NOT TO BE
COMMUNICATED EITHER DIRECTLY OR INDIRECTLY TO THE
PRESS OR TO ANY PERSON NOT AUTHORIZED TO RECEIVE IT

AUSTRALIAN MILITARY FORCES

IDENTIFICATION LIST

KEYS, TELEGRAPH, LIGHTWEIGHT, (AUST.) NO. 1

1956

PREFACE

AIM

This Identification List is prepared for the visual identification of items comprising the equipment. Every item and assembly is therefore listed.

ISSUING AUTHORITY

This Identification List is issued by MGO Branch, AHQ.

ILLUSTRATIONS

Those items not illustrated are indicated thus - "Ø".

MAINTAINABLE ITEMS

Maintainable items normally stocked by RAAOC are indicated thus - "*".

AMENDMENTS

Amendments will be issued at six monthly intervals from the date of this publication, and notified in AAO's.

LIST OF AMENDMENTS							
Amt. Ser.No.	Authority	Amended by -	Date	Amt. Ser.No.	Authority	Amended by -	Date

ABBREVIATIONS

AF	-	-	across face
As req.	-	-	as required
BA	-	-	British Association
br.	-	-	brass
cad.pl.	-	-	cadmium plated
ch.hd.	-	-	cheese head
contd.	-	-	continued
cpr.	-	-	copper
c'sk.hd.	-	-	countersunk head
ET	-	-	electro-tinned
hex.	-	-	hexagon
in.	-	-	inches
lg.	-	-	long
LH	-	-	left hand
M. Pt. No.	-	-	Maker's Part No.
MS	-	-	mild steel
No.	-	-	number
Ref.	-	-	reference
RH	-	-	right hand
st.	-	-	steel
w.	-	-	with

KEYS, TELEGRAPH, LIGHTWEIGHT, (AUST.) No. 1

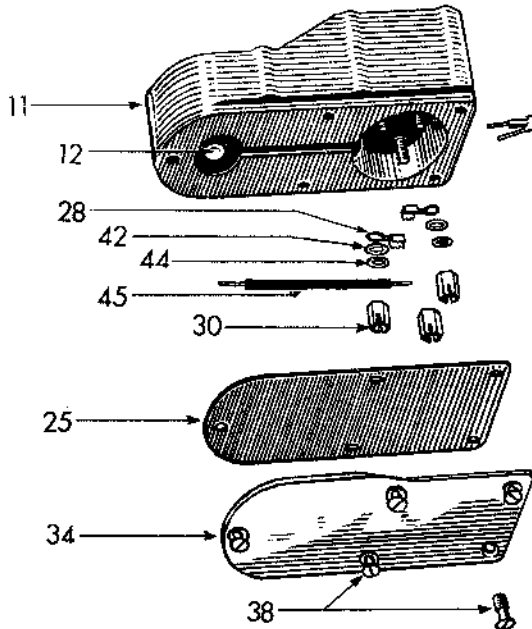
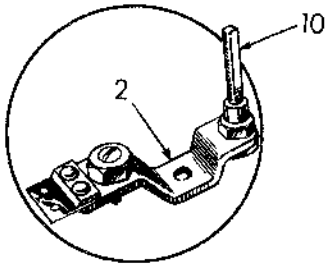
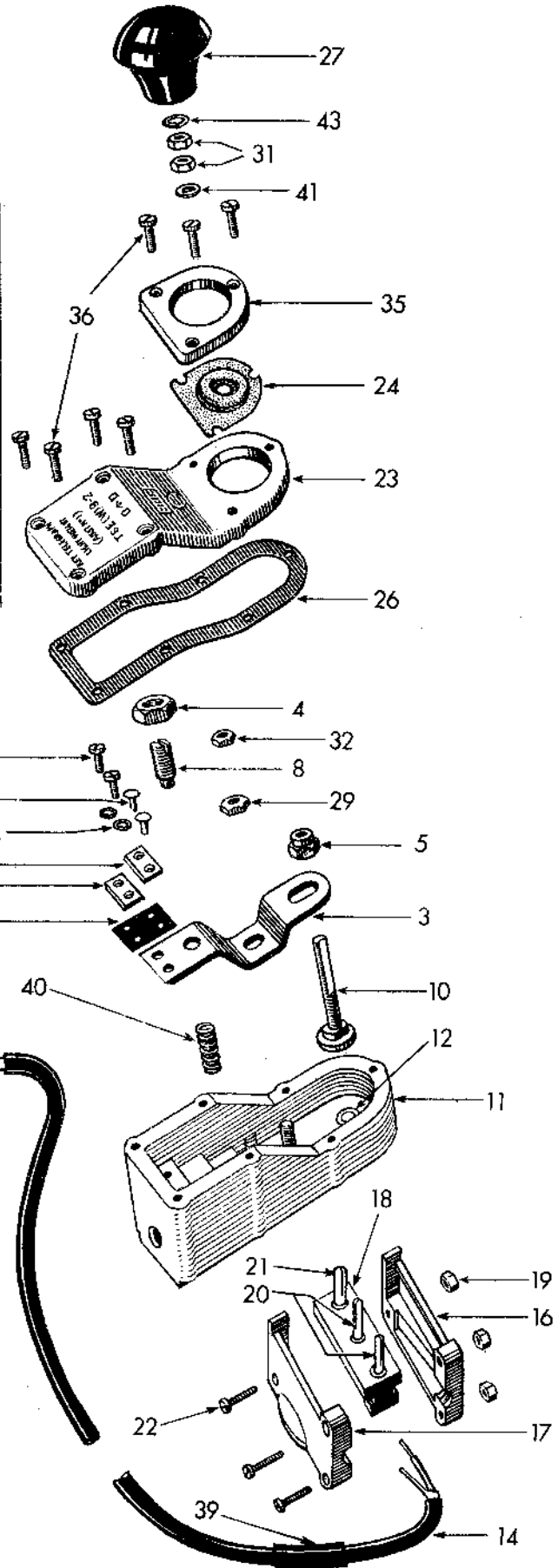
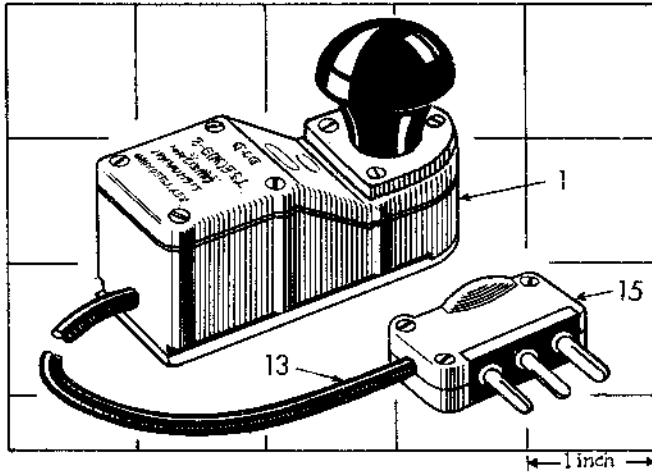

RESTRICTED

PLATE REF. NO.	DESIGNATION	CATALOGUE NO.	NO. OFF	DRAWING NO. OR REMARKS
1 *	KEYS, TELEGRAPH, LIGHTWEIGHT, (AUST.), NO. 1	Y1/TSE(W)9-2		
2	ARM ASSEMBLIES		1	TSE(W)9-15 M. Pt. No. 31603
3	ARMS		1	TSE(W)9-16 M. Pt. No. 31625
4	NUTS, lock, 2BA, hex., MS, cad.pl.		1	
5	NUTS, 4BA, hex., w/collar, 1/4 in. AF, MS, cad.pl.		1	TSE(W)9-13 M. Pt. No. 31630
6	PLATES		1	TSE(W)9-20 M. Pt. No. 31604
7	RIVETS		2	TSE(W)9-19 M. Pt. No. 31629
8	SCREWS, grub, 2BA, br., ET, cad.pl.		1	TSE(W)9-17 M. Pt. No. 31627
9	SPRINGS		1	TSE(W)9-18 M. Pt. No. 31628
10	POINT ASSEMBLIES		1	TSE(W)9-21 M. Pt. No. 31626
...	BODIES		1	TSE(W)9-23 } Braised
...	POINTS	Ø	1	TSE(W)9-22 } together.
11	BODY ASSEMBLIES		1	TSE(W)9-3 M. Pt. No. 31601
...	BODIES		1	TSE(W)9-3 M. Pt. No. 31601
...	INSERTS		1	TSE(W)9-4 M. Pt. No. 31616
...	INSERTS		4	TSE(W)9-5 M. Pt. No. 31617
...	INSERTS		6	TSE(W)9-6 M. Pt. No. 31618
...	INSERTS		2	TSE(W)9-7 M. Pt. No. 31619
...	INSERTS		1	TSE(W)9-8 M. Pt. No. 31620
...	PINS		1	TSE(W)9-9 M. Pt. No. 31621
12	POINT ASSEMBLIES		1	TSE(W)9-10 M. Pt. No. 31615
...	BODIES		1	TSE(W)9-11 } Braised
...	POINTS		1	TSE(W)9-12 } together.
13	CORD AND PLUG ASSEMBLIES		1	
14 *	CABLE, electric, miniature, No. 1C	Y3/6145-100001	As req.	M. Pt. No. 32432
15 *	PLUGS, 3-pin	Y1/TSE(W)47-2	1	
16	HOUSINGS, LH		1	TSE(W)47-6
17	HOUSINGS, RH		1	TSE(W)47-7
18	MOULDINGS		1	TSE(W)47-3
19	NUTS, 8BA, hex., br., cad.pl.		3	
20	PINS		2	TSE(W)47-4
21	PINS		1	TSE(W)47-5
22	SCREWS, 8BA, ch. hd., 5/16 in. lg., br., cad.pl.		3	
23	COVERS, body		1	TSE(W)9-24 M. Pt. No. 31605
24	DIAPHRAGMS		1	TSE(W)9-32 M. Pt. No. 31612
25	GASKETS	Y1/TSE(W)9-29	1	M. Pt. No. 31609
26	GASKETS		1	TSE(W)9-31 M. Pt. No. 31611
27 *	KNOBS, moulded	Y1/TSE(W)9-13	1	M. Pt. No. 31602
...	INSERTS	Ø	1	TSE(W)9-14 M. Pt. No. 31624
28	LUGS, solderless, 8BA, tinned opr.		2	M. Pt. No. H 290
29	NUTS, 6BA, hex., br., ET, cad.pl.		1	TSE(W)9-33 M. Pt. No. 31613
30	NUTS, 8BA, hex., slotted, br., cad.pl.		3	TSE(W)9-25 M. Pt. No. 31606
31	NUTS, lock, 4BA, hex., br., ET, cad.pl.		2	
32	NUTS, lock, 6BA, hex., br., ET, cad.pl.		1	
33	PLATES		1	TSE(W)9-20 M. Pt. No. 31604
34	PLATES, base		1	TSE(W)9-28 M. Pt. No. 31608
35	RINGS		1	TSE(W)9-26 M. Pt. No. 31607
36	SCREWS, 8BA, ch. hd., 1/4 in. lg., br., ET, cad.pl.		7	
37	SCREWS, 8BA, ch. hd., 3/16 in. lg., MS		2	
38	SCREWS, 8BA, c'sk. hd., 1/4 in. lg., MS		5	TSE(W)9-34 M. Pt. No. 31614
39	SLEEVES, identification		1	
40	SPRINGS		1	TSE(W)9-27 M. Pt. No. 25790

KEYS, TELEGRAPH, LIGHTWEIGHT, (AUST.), No. 1

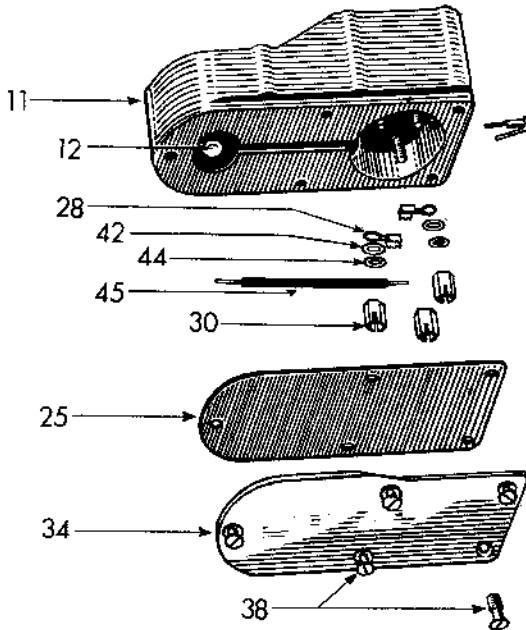
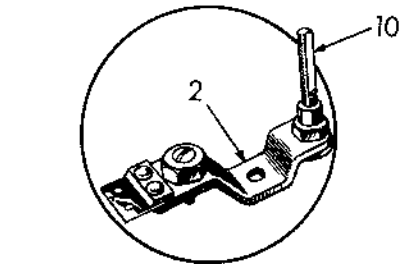
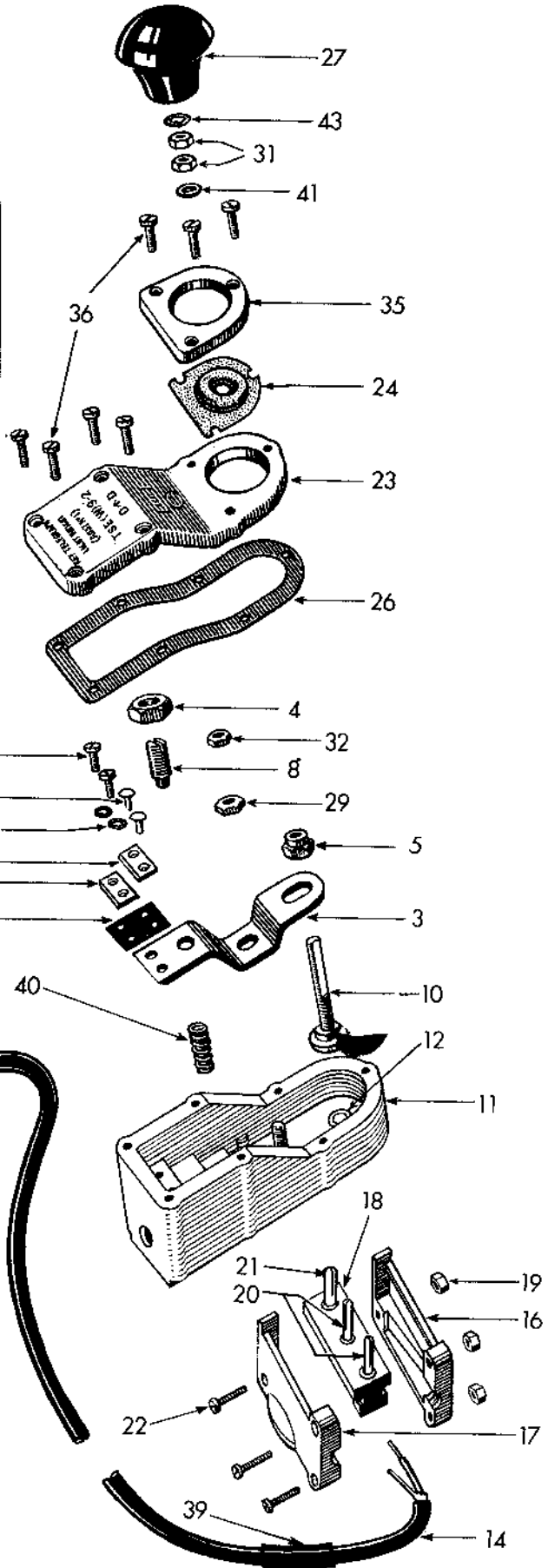
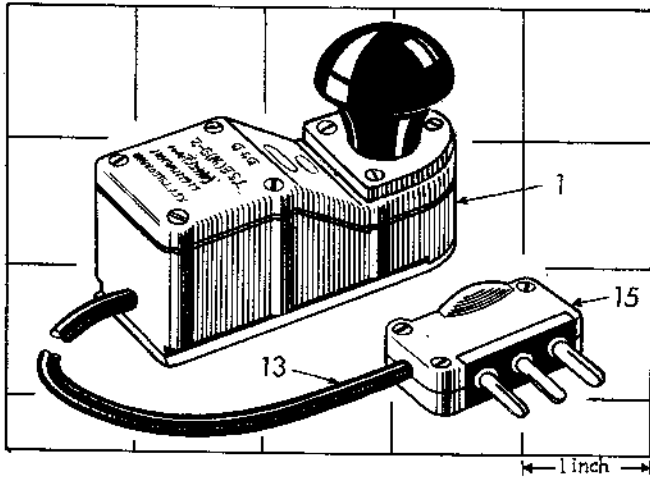

PLATE REF. NO.	DESIGNATION	CATALOGUE NO.	NO. OFF	DRAWING NO. OR REMARKS
41	WASHERS, ET, cad.pl.		1	TSE(W)9-35 M. Pt. No. 31654
42	WASHERS, plain, large, 8BA, br., ET, cad.pl.		2	
43	WASHERS, spring, 4BA, st., cad.pl.		1	
44	WASHERS, spring, 8BA, st., cad.pl.		4	
45	WIRE, 20 SWG, tinned cpr., w/nylex sleeve		As req.	
REPAIR KITS				
...*	KITS, repair, No.1 (Aust.) lightweight telegraph key, consisting of :-	Y1/YAA 1436	1	
3	ARMS		1	TSE(W)9-16 M. Pt. No. 31625
7	RIVETS		2	TSE(W)9-19 M. Pt. No. 31629
9	SPRINGS		1	TSE(W)9-18 M. Pt. No. 31628
24	DIAPHRAGMS		1	TSE(W)9-32 M. Pt. No. 31612
26	GASKETS		1	TSE(W)9-31 M. Pt. No. 31611
33	PLATES		2	TSE(W)9-20 M. Pt. No. 31604
37	SCREWS, 8BA, ch.hd., 3/16 in.lg., MS		2	
40	SPRINGS		1	TSE(W)9-27 M. Pt. No. 25790
44	WASHERS, spring, 8BA, cad.pl.		2	
...*	KITS, repair, cord and plug assembly, consisting of :-	Y1/YAA 1437	1	
13	CORD AND PLUG ASSEMBLIES ..		1	
28	LUGS, 8BA, solderless, tinned cpr.		2	M. Pt. No. H 290
44	WASHERS, spring, 8BA, cad.pl. ..		2	

RESTRICTED