

A Comprehensive Guide Book for the  
**HAM RADIO ENTHUSIASTS**



Sandeep Baruah, Scientist-F  
**Vigyan Prasar**  
Department of Science & Technology  
C-24, Qutab Institutional Area  
New Delhi-110 016  
E-mail: [sandeep@vigyanprasar.gov.in](mailto:sandeep@vigyanprasar.gov.in)

# CONTENT

<b>Part-I: Introduction to ham radio</b>	<b>PAGE</b>
A. What is Ham Radio?	1
B. Why an Amateur Radio Operator is called a ham?	2
C. What is the minimum qualification to become a ham?	3
D. What is an amateur radio call-sign?	3
<b>Part-II: Amateur Radio Rules &amp; Regulation</b>	
A. Detailed procedures related to application for a ham radio licence.	4
B. Different grades of licencing examinations and licences.	5
C. The Indian Wireless Telegraphs (Amateur Service) Rules, 1978.	6
D. Syllabus of Amateur Station Operator's Certificate (ASOC) Examination.	28
E. Question and answer section on amateur radio rules & regulations	33
F. Radio telephony operating procedure.	41
G. Radio telegraphy operating procedure.	43
<b>Part-III: Radio Theory and Practice</b>	
A. Elementary theory of electricity & magnetism	47
B. Thermionic emission & valves	77
C. Semiconductor devices	80
D. Radio receivers	86
E. Transmitter	97
F. Radio wave propagation	103
G. Aerials	109
<b>Part-IV: Learning the International Morse Code.</b>	117
<b>Part-V: Safety measures in a ham radio shack.</b>	121
Annexure-I: List of Wireless Monitoring Stations	
Annexure-II: Call-sign Prefixes of Amateur Radio Stations of different countries allotted by the International Telecommunication Union (ITU)	
Annexure-III: Sample Question Papers for the Amateur Radio Licencing Examination	

**RADIO BASED APPROACH FOR DISASTER RISK  
REDUCTION AND MANAGEMENT USING AUTOMATIC  
PACKET REPORTING SYSTEM (APRS®) AND HAM  
RADIO (AMATEUR RADIO) DIGITAL COMMUNICATION  
TECHNOLOGIES**

S. BARUAH

*Vigyan Prasar, Department of Science & Technology  
C-24, Qutab Institutional Area  
New Delhi 110 016  
sandeep@vigyanprasar.gov.in*

**ABSTRACT**

In the event of any large scale disaster, due to the breakdown of conventional modes of communication (mobile phone, land line phone, Internet etc.) disaster management becomes a difficult task for various governmental and non-governmental emergency responders. So it is of utmost importance to keep in place an alternative communication service up and running which can work as a second line of communication utilizing radio waves. During many of the past large scale disasters all over the world, Amateur Radio Service (ham radio) proved its efficacy in quick dissemination of disaster management information (search and rescue, relief work, tracking of missing person, real-time plotting of vehicles and personnel involved in disaster management, transmission of weather telemetry data etc.). Amateur Radio Service is a non-commercial licensed service utilized by voluntary radio experimenters and radio enthusiasts regulated by the telecommunication authority. Automatic Packet Reporting System -- APRS® (Registered Trademark of Bob Bruninga, US Naval Academy) is a digital radio communication technology which augments the scope of application of Geographical Information System (GIS) for disaster management. Vigyan Prasar is involved in coordination of disaster management activities during many of the past large scale disasters gaining expertise in digital technologies for disaster risk reduction and management through its state-of-the-art radio communication system.

**1. INTRODUCTION**

Most of the disasters are unpredictable and in a country as big as India with population exceeding 120 crore, it creates havoc in terms of loss of human life and other valuable property. Governmental agencies and NGOs employ different means to predict location, route and extent of disaster with a probable time frame. Due to the lack of adequate low-cost radio technology infrastructure in our country, the emergency responders are facing problems in disaster risk reduction works, pre-disaster communication in disaster prone areas and post-disaster management.

The author being a licensed amateur radio experimenter (ham radio hobbyist) with the government allotted call-sign VU2MUE (Baruah, 1999a) for the last twenty five years (licensed in 1989) was involved in emergency disaster communication during many of the large scale disasters (Arya, A.S., et. al. 2005 and 2006) that our country has gone through. A study was done by Baruah in 2004a on Ham Radio for Disaster Communication. The role of ham radio operators in India during the Tsunami disaster in 2004 was documented in details by Baruah, 2004b. Baruah, 2012 discussed in detail about live RF data on an interactive Internet map. It is realized that without the integration of GIS Technology and Amateur Radio Digital Communication Technology at grass root level Emergency Operation Centres (EOCs), it would remain a far flung dream for the government to come out with a mechanism that would not only ensure an effective linkage between the people living in disaster prone areas with that of those who are involved in disaster management. A countrywide Amateur Radio emergency digital communication network can be established under the Indian Wireless Telegraph Amateur Service Rules of the Department of Telecommunications (Baruah, 1999b).

## **2. MATERIALS AND METHOD**

### **2.1 GEOGRAPHICAL INFORMATION SYSTEM (GIS) AND PACKET RADIO**

Geographical Information System (GIS) broadly describes any information system that integrates, stores, edits, analyses, shares and displays geographic information (called the geospatial data) for decision making in an interactive map. For government licensed *amateur radio experimenters* (most of whom might not have the professional knowledge of GIS) to use their two-way radio communication equipment for automatic transmission of GIS data/information, Automatic Packet Reporting System (APRS) is the most suitable mode. APRS (Bruninga, 2002) is evolved from its predecessor ham radio communication technology called Packet Radio (Ackermann, 2002) which is a digital mode of Amateur Radio (Ham Radio) communications which corresponds to computer telecommunications. The telephone modem is replaced by a "magic" box called a terminal node controller (TNC); the telephone is replaced by an amateur radio transceiver (a combined unit of radio transmitter and receiver), and the phone system is replaced by the "free" amateur radio waves. Packet radio takes any data stream sent from a computer and sends that via radio to another amateur radio station similarly equipped. Packet radio is so named because it sends the data in small bursts, or packets (Kenney, 1995). Interfacing of the computer through its serial communication port (RS232) to the two-way radios is done through suitable radio modems. In the absence of RS232 serial ports, serial to USB adaptor cables are utilized by radio experimenters which provide 1200 baud and 9600 baud data transmission speed in the government allotted Very High Frequency amateur band (VHF: 144-146 MHz) and Ultra High Frequency (UHF: 434 to 438 MHz) amateur bands. 9600 baud is approximately 960 unencrypted digitally transmitted characters in one second. Though amateur radio experimenters have been utilizing the AX.25 Packet Radio protocol (Beech et.al, 1998) since late 70s for transmission of texts (transfer of text files from one computer to another computer using radio waves), data, binary file transfer over the radio and for two way interactive digital communication (text chat as well as Bulletin Board System for file/mail storage and retrieval) using walkie-talkies interfaced to the computer, in the recent time Automatic Packet Radio System (APRS®) is gaining popularity as it provides all the information graphically on a map that is of immense utility in disaster management. Graphical representation (through standardized icons) of various geospatial information (e.g. Earthquake, cyclone, relief camp, Emergency Operation Centre-EOC, ambulances, hospitals, different type of vehicles etc. (Figure 1, 2 and 3) make all emergency management related information available to the emergency responders just at the click of the mouse button. Open source and free computer software like UI-VIEW (Barker, 2004) and

APRSIS32 (Deffenbough, 2009) are available on the internet for different operating system which can be utilized at the Emergency Operation Centres (EOCs) for transmission and monitoring of geospatial information on maps using radio. IGate (Bruninga, 2015) is a radio to internet gateway system utilized by ham radio operators to feed radio frequency data to internet and make these available all over the world.

## 2.2 PACKET RADIO STATION

For APRS® to be utilized for disaster risk reduction and disaster management, the basic packet radio station consist of a Very High Frequency (VHF) two-way radio interfaced to the computer through a TNC (Terminal Node Controller) and a software application for digital communication (Figure 1) The two way radio is connected to an external antenna for transmission and reception of digital data. The function of the TNC is to encode and decode the data. The software, also sometime called a terminal programme displays the data in human readable format. The GUI (Graphical User Interface) software also allows the user to connect to a station, sending text message as well as transfer of files from his/her computer to the other connected computer (connected through radio waves). Packet is communications between people either director indirect. Emergency responders can work keyboard to keyboard or use electronic mailboxes to leave messages. Due to error checking by the TNC, all of it is error free, too. As the data is received it is continuously checked for errors, and isn't accepted unless it is correct. We don't miss the information if it has errors because the information is resent again. The data that is to be transmitted is collected by the TNC and sent in bursts, or packets, of information; hence the name. Each packet has the call-sign (Baruah, 1999c) or address of who it's going to, who it's coming from and the route between the two stations included, along with the data and error checking. Since up to 256 characters can be included in each packet, more than three lines of text can be sent in a matter of a couple of seconds. Packet Networks allow amateurs to widen the area of communications past their line of sight, by having a series of packet stations linked by radio that can be used to get their packet messages to where ever the network goes.

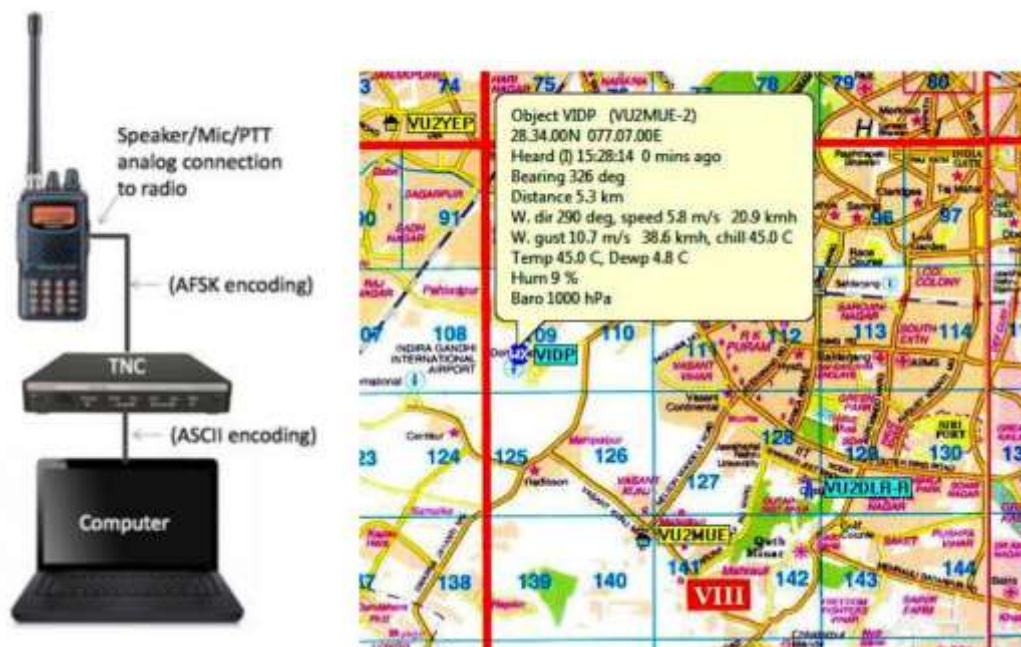

Figure 1: Packet radio stations when use APRS technology, the radio originated information are displayed graphically. In the above figure four radio stations are plotted on a map as per the position information transmitted by these stations. Distance, bearing, time of reporting on map are all automatically archived and available to the radio user.

### 2.3 AUTOMATIC PACKET REPORTING SYSTEM (APRS®)

APRS is a real-time tactical digital communications protocol for exchanging information between a large number of stations covering a large (local) area. As a multi-user data network, it is quite different from conventional packet radio (Bruninga, 2002) APRS is different from regular packet in four ways. First by the integration of maps and other data displays to organize and display data, second, by using a one-to-many protocol to update everyone in real time, third, by using generic digipeating so that prior knowledge of the network is not required, since 1997, a worldwide transparent internet backbone, linking everyone worldwide. APRS turns packet radio into a real-time tactical communications and display system for emergencies and public service applications (and global communications). Normal packet radio is useful in passing bulk message traffic (Email) from point-to-point, but it does not do well at real time events where information has a very short life time and needs to get to everyone quickly. APRS is a LOCAL RF network. Although the Internet monitors APRS worldwide, this is not the primary objective. But like all of our other radios, how we use APRS in an emergency of special event is what drives the design of the APRS protocol. Although APRS is used 99% of the time over great distances, and benign conditions, the protocol is designed to be optimized for short distance real-time crisis operations on RF (Bruninga, 2002). An Internet Gateway (IGate) station can feed the local RF originated Geospatial packet data to a network of worldwide APRS-IS (Internet Server) extending the range of APRS communication. These data can be viewed even a layman by accessing websites like <http://aprs.fi> and <http://www.riverdevil.org/APRS/vu2mue>. Peter Loveall's javAPRS (Loveall, 2006) enables demonstration of ham to non-ham communication (Non-hams can only monitor APRS ham activities using their Internet Browsers). Its utility during an emergency situation is self-explanatory.

### 2.4 INTEGRATION OF RADIO AND INTERNET

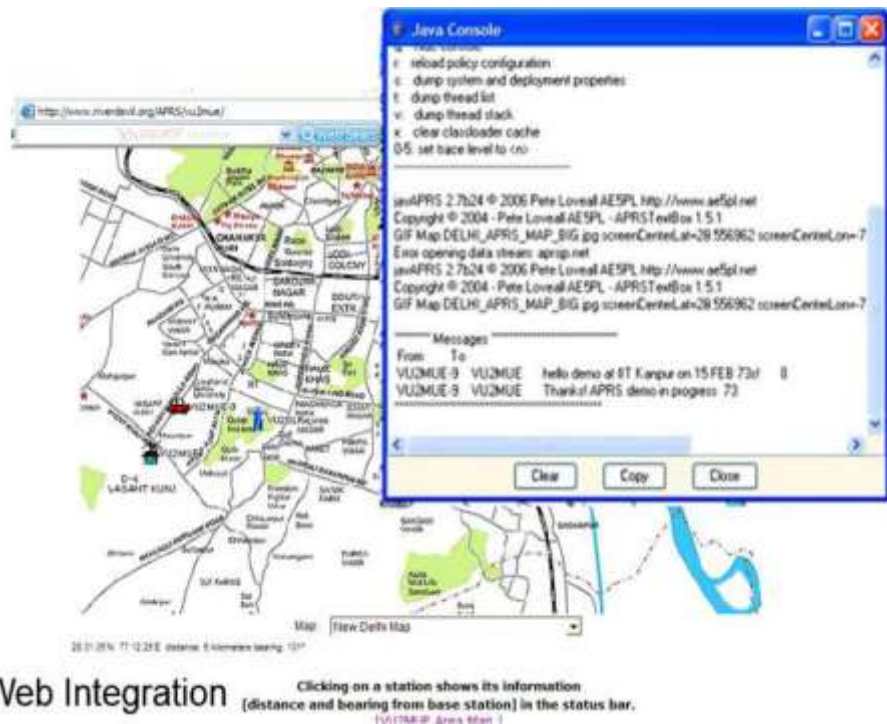

Figure 2: The author's website <http://www.riverdevil.org/APRS/vu2mue> demonstrates the ham radio capability to feed radio originated data to Internet, which can be represented graphically on a user customized map. In the above figure, text messages transmitted from the car is received by another radio connected to computer is displayed on the Java console. The car can be plotted in real-time on the map.

The author has developed a technology demonstration web page <http://www.riverdevil.org/APRS/vu2mue> to demonstrate the amateur radio capability in penetrating the Internet to serve useful purposes for disaster management. This is a live APRS® data feed page utilizing javAPRS where radio originated emergency messages can be read on the Microsoft Sun JAVA console. APRS® is not to be mistaken just as a mere automatic vehicle tracking system. It is real-time two way digital radio communication where many of the vital geospatial information are exchanged almost automatically. People can monitor APRS® digital communication using this type of Internet web page as well as on their radios. GUI application like UI-VIEW enables creation and calibration of localized maps even without the use of GPS receivers and accurate plotting of real-time geospatial data for disaster management is possible on these maps which can be of immense utility during disaster management. The map demonstrates the utility of an Interactive Internet map. This APRS map is accessible to hams as well non hams too. Text messages originated from RF stations (stations who are in remote places and not connected to Internet) can be monitored by non-hams. This has utility in ham radio emergency communication too. By pressing 'M' the RF originated messages can be read the read message on the Java Console.

## 2.6 APRS® APPLICATIONs IN DISASTER MANAGEMENT

Accurate automatic position information (graphical plotting on map) about mobile & fixed stations in real-time including web based archiving of positions of resources (people, vehicle, property); Direction (Bearing/Angle) information for prompt Search and Rescue Operation; Tracking a mobile station (useful during emergency operation/tactical situation when prompt receipt of information about positions and progress of mobile stations is of utmost necessity for efficient coordination); Line-of-Sight (LoS) Distance and bearing of stations from base station available just at the click of a button; Monitoring of 'radio to radio digital text messages' on an Internet browser. During emergencies, if the Internet does not fail, this would help people to monitor emergency messages using Sun Java console on the Internet browser; Monitoring of real-time weather information originated from ham radio weather stations (Real-time Weather information like Wind Speed, Wind Direction, Temperature, Barometric Pressure, Humidity, Rainfall etc. are available on this map with just the click of a button e.g. at the URL <http://aprs.fi/?call=VU2MUE-2>; Plotting of objects on the map. For example an accident site, crash site, intimation about a traffic jam for route planning, fire site, flood, cyclone, earthquake, land-slide, road blockage or information about an event etc.; Allows important information to be exchanged without human intervention. This is important during a tactical or emergency situation, when emergency responders have to concentrate on other important jobs,e.g. 'Search & Rescue Operation'.



Figure 3: Real time plotting of mobile stations on internet as well as standalone computers connected to radio. Last reported time and position, bearing and distance from control room etc. are just at the click of a button.

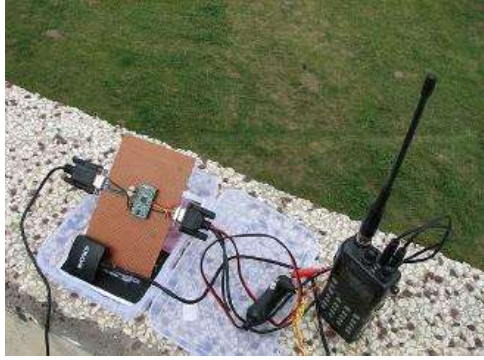

Figure 4: Author's radio setup with an assembled radio modem which can be interfaced to a GPS receiver and weather sensors for real-time transmission of location as well as weather information. These information can be received by a similarly equipped radio station interfaced to the computer. The received information are displayed graphically in UI-view software as in shown in figure 1 and 3.

## CONCLUSION

As radio waves allotted by the government to the amateur radio experimenters are free of cost and the cost of two-way radio communication devices are going down, a countrywide network of voluntary hams utilizing APRS® is a need of the hour which can involve a vast section of the society to be self-reliant in disaster risk reduction and disaster management would become more efficient.

## REFERENCES

- Ackermann, J., (2002) Packet Radio Basics  
<http://nebula.wsimg.com/956808877754f8b2e3e5107ab910f4a9?AccessKeyId=13BB62BA17C994AA56AC&disposition=0&alloworigin=1>
- Arya, A.S., Agarwal, A., Nagaraju, A., Karanth, A., Menon, K., Venkatachalam, A., Dey, B., Karelia, H., Narayanan, M., (2005 and 2006) TOGETHER, TOWARDS, A SAFER INDIA PART-III A textbook on disaster management for class X: 28  
<http://www.cbse.nic.in/DM%20ENGLISH.pdf>
- Baruah, S., (1999a) Ham Radio for the wireless Enthusiasts  
[http://www.qsl.net/vu2msy/sandeep\\_baruah.htm](http://www.qsl.net/vu2msy/sandeep_baruah.htm)
- Baruah S., (1999b) The Indian Wireless Telegraph (Amateur Service) Rules, 1978 <http://www.qsl.net/vu2msy/asocrules.htm>
- Baruah, S., (1999c) What is an amateur radio call-sign? <http://www.qsl.net/vu2msy/callsignFAQ.htm>
- Barker, R. (2004) UI-view <http://www.ui-view.net/>
- Baruah, S., (2004a) Ham Radio for Disaster Communication. VIPNET NEWS (8): 10  
[http://www.qsl.net/vu2msy/Emergency\\_Ham\\_Communication\\_in\\_India.pdf](http://www.qsl.net/vu2msy/Emergency_Ham_Communication_in_India.pdf)
- Baruah, S., (2004b) Hams came to the rescue of Tsunami struck distressed people in India.  
[http://www.qsl.net/vu2msy/Hams\\_came\\_to\\_the\\_rescue\\_of\\_Tsunami\\_struck\\_distressed\\_people\\_in\\_India.htm](http://www.qsl.net/vu2msy/Hams_came_to_the_rescue_of_Tsunami_struck_distressed_people_in_India.htm)
- Baruah, S., (2012) Live RF data on an interactive Internet map.  
<http://www.riverdevil.org/APRS/vu2mue>
- Beech, W., Nielsen D., Taylor, J., (1998) AX.25 Link Access Protocol for Amateur Packet Radio <http://www.ax25.net/AX25.2.2-Jul%2098-2.pdf>
- Bruninga, B., (2002) Automatic Packet/Position Reporting System (APRS) <http://www.aprs.org/APRS-docs/APRS.TXT>
- Bruninga, B., (2015) IGate Design <http://www.aprs-is.net/IGating.aspx>
- Deffenbough, L., (2009) APRSISCE/32 The future of Amateur Radio APRS <http://aprsisce.wikidot.com/>
- Kenney, L., (1995) Introduction to Packet Radio <http://choisser.com/packet/>
- Loveall, P., (2006) <http://www.ae5pl.net/>

## Part-I

# Introduction to Ham Radio

### A. What is Ham Radio?

Ham radio operators are a group of people nurturing a special interest in wireless communication technology. People from all the spheres of life are found among the ham radio operators. They operate their wireless transceivers (a combined unit of radio transmitter and receiver) during their spare time for the sheer joy, thrill and excitement involved in doing a worldwide radio communication. Unlike the broadcast radio stations (to whom we usually tune our radio receivers to listen to), ham radio is a two-way communication system. Ham radio operators can put their voice on-the-air to be listened into and at the same time replied back by their fellow radio operators around the world, usually with very low power devices.

Despite the existence of other communication facilities, ham radio operators run their own wireless communication network with entirely personal effort, out of the love for this medium of communication. There are some hams who, build their own wireless transceivers (a combined unit of transmitter and receiver) and transmit their voice signals throughout the world to be replied back by their fellow hams. These are the experiment oriented hams who try to achieve some sort of a perfection in developing electronic circuits for radio frequency work, or at a lower level, they may like to assemble a piece of wireless equipment designed by their fellow experts, modify it in their own way to improve its performance till they are satisfied with its performance. Hams located in the other parts of the world reply back exchanging information about the quality and strength of their radio signals.

They exchange personal as well as technical information, which are not related to business or commerce, politics and religion. Though a ham cannot use his radio station for any pecuniary gain, a creative mind can still find numerous utility of ham radio. It is a pursuit, which attracts people from all the spheres of life. There are hundred and thousands of people who are laymen so far as their knowledge of electronics is concerned, yet, they are expert ham radio operators. It is an exciting way to discover new friends and disseminate knowledge on -the-air. One interesting fact about ham radio communication is that hams don't have to pay any money to the authority for their on-the-air conversation.

With the availability of low cost easily replicable circuits of radio transmitters and receivers, the number of ham radio operators increased to millions. The growth of electronics communication technology is also considered to be going hand in hand with the progress of ham radio. The advancement in the field of electronics and the flourishing growth of electronics industry in countries like Japan has been very often attributed to the presence of large group of dedicated ham radio operators (to the tune of 13,50,127).

Though ham radio is a highly **specialized technical hobby**, it requires **no special qualification** (except that the person going to be a ham has attained 12 years of age). However, it demands immense interest in radio communication and sufficient enthusiasm to operate a radio station of your own. Ham radio, also known as

"**Amateur Radio**" does not provide any pecuniary gain. However, what you gain from being a ham is more than what money can give and for that you got to be imaginative! Many of the foremost radio and electronics engineers and technicians operate as amateurs during times when they are not occupied professionally. Seeing the growth of ham radio population around the world, many professional companies started manufacturing ham radio equipment to meet the needs of the vast group of ham radio operators, who prefer readymade professionally built equipment instead of homemade ones. So, what had once been a hobby for somebody, turned out to be a profitable industry for some others. Hams never accept money for their on-the-air communication.

Young students can learn the principles of electronics through practical experimentation by assembling wireless transmitter and receiver kits in the ham radio clubs established in their schools. Without a valid ham licence, it is illegal to operate wireless equipment. In India, the **Central Board of Secondary Education (CBSE)** has also taken some initiative to include 'ham radio' in their course curriculum under the scheme of Work Experience. **The Member of Parliament Local Area Development Scheme** has also included 'Ham Radio' as one of its projects. As per the directive of the **Ministry of Programme Implementation, a Member of Parliament (MP) can spend money to establish ham radio stations in the schools located in his area.** If these schemes are fruitfully utilised, many youngsters would be able to take interest in ham radio which they may also make into career. There are many activities people perform out of their scientific curiosity or to satisfy their inquisitive mind. Many people are attracted towards ham radio for this reason also.

## B. Why an Amateur Radio Operator is called a ham?

As per the Florida Skip Magazine (1959), the word "HAM" was coined in **1908** from the station CALL of the first amateur wireless station operated by some amateurs of the **Harvard Radio Club**. They were Albert S. **Hyman**, Bob **Almy** and Pogie **Murray**. At first they called their station "**Hyman- Almy- Murray**". Tapping out such a long name in code soon became tiresome and called for a revision. They changed it to "**Hy-Al -Mu**", using the first two letters of each of their names. **Early in 1901** some confusion resulted between signal from amateur wireless station "Hy-Al-Mu" and a Mexican ship named "HYALMO". **They then decided to use only the first letter of each name and the station CALL became "HAM"**.

During those days of unregulated radio, amateur radio operators picked their own frequency and call letters. Then as now, some amateurs had better signals than commercial stations. **The resulting interference came to the attention of US congressional committees in Washington DC and the Congress proposed a legislation to critically limit the amateur radio activity. In 1911, Albert Hyman chose the controversial Wireless Regulation Bill as the topic for his thesis at Harvard.** His instructor insisted that a copy be sent to Senator David L. Walsh, a member of one of the committees hearing the Bill. The Senator was so impressed with the thesis that he asked Hyman to appear before the committee. Albert Hyman took the stand and described how the little station was built and almost cried when he told the crowded committee room that if the BILL went through they would have to close down the station because they could not afford the license fee and all the other

requirements which the BILL imposed on amateur stations. **Congressional debate began on the Wireless Regulation Bill and little station "HAM" became the symbol for all the little amateur stations in the country crying to be saved from the menace and greed of the big commercial stations who didn't want them around.** The BILL finally got to the floor of Congress and every speaker talked about the "**....poor little station HAM.**" That's how it all started. The whole story can be found in the US Congressional Record. Nation-wide publicity associated the station "HAM" with other amateur radio operators. From that day to this, and probably until the end of time in radio; an amateur radio operator is a "HAM".

### C. What is the minimum qualification to become a ham?

**No educational qualification is specified** to become a ham. Anybody who has **attained 12 years of age** can become a ham radio operator after passing the **Amateur Station Operator's Certificate (ASOC) Examination** conducted by the **Ministry of Communications, Govt. of India.** You have to send a "**Birth Certificate** " or the "**High School Leaving Certificate**" (which mentions your date-of-birth) as a proof of your age.

**There are four different grades of Amateur Wireless Telegraph Station Licence.** Those between the **age group of 14-18 years** can apply for **Grade-I, Grade-II, Restricted Grade or a Short Wave Listener's licence** (listening to the ham radio operators without this licence is considered illegal). Those between the **age group of 12-14 years** can apply for **Grade-II, Restricted Grade or a Short Wave Listener's Licence.** The application for the grant of such licences should be accompanied by a certificate from the head of the educational institution recognized by a board or university in India, attended by the consent of the applicant or from his legal guardian that the applicant is interested in and is competent to conduct experiment in wireless communication.

### D. What is an amateur radio call-sign?

Each **amateur radio station (ham radio station)** has its own unique "**name**" allotted by the authorities. In amateur radio, **the unique name assigned to a ham radio station and its owner** helps you to know **its operator** as well as **the country** to which he/she belongs. A particular ham radio station is authorized to be operated by that particular ham radio operator only. However, other licensed ham radio operators are also eligible to operate his station, provided, the owner of that particular station is physically present during the operation. **A person who does not hold a ham radio licence is not authorized to operate a ham radio station.** This also means that only a single station with a particular call-sign can exist in a particular location. A person having a ham radio call-sign is not authorized to set up more than one ham radio station.

A call-sign consists of a set of letters and numbers, assigned by the authority. For example **VU2XYZ** is a call-sign which belongs to a particular ham in India. No other hams anywhere in the world can have this call-sign! Similarly, **4S7VK** is a call-sign which belongs to a ham from Sri Lanka. In a call-sign, the first 2 (or 3)

characters are called the **prefix**. So, there might be a ham with the call-sign 4S7XYZ in Sri Lanka. Similarly, a call-sign like VU2VK may exist in India! Each country has its own prefix. The knowledge of prefix helps us in identifying the country of origin of a particular amateur radio transmission (List of prefix at Annexure-II).

When a ham radio station is set up on board a ship, the call-sign should be followed by the suffix /MM. So, VU2XYZ would become VU2XYZ/MM (**maritime mobile**) when it operates from a ship. If it operates from a vehicle, then the call-sign becomes VU2XYZ/M (**mobile**).

## Part-II

### Amateur Radio Rules & Regulation

#### A. Detailed procedures related to application for a ham radio licence

An examination is held for licensing of Amateur Stations. It is conducted by the **Wireless Planning and Co-ordination wing (WPC) of the Ministry of Communications, New Delhi** at 22 **Wireless Monitoring Stations** located throughout the country. You should apply to the 'Officer-in-Charge' (OC) of the Monitoring Station nearest to your hometown. Basically the examination consists of a **100 marks question paper** (50 marks related to basic radio/electronics theory as per the syllabus and 50 marks related to Amateur Radio Rules & Regulations) which is of **one, two or three hours** duration as per the "grade" of licence you intend to appear. There are 4 grades. You can apply for more than one grade at a time, provided, separate application forms along with the prescribed examination fees, for each grade in the form of **Demand Draft** issued from a "**State Bank of India**" branch drawn **in favour of the "Pay & Accounts Officer (Headquarters), Department of Telecommunications, New Delhi-110 001, payable at SBI New Delhi Service Branch (Code No. 7687)** are sent to the "**Officer-in- Charge**" of the **Wireless Monitoring Station (in no case application be forwarded to WPC Wing, New Delhi)** where you will be appearing for the ASOC examination.

The particulars of the "Venue" and "Date" etc. of the examination will be communicated by the Officer-in-Charge of the concerned Wireless Monitoring Station on receipt of completed application form with the requisite examination fees

Following should accompany the application:

- (1) **Nationality Certificate/Character Certificate** in the prescribed proforma (find the proforma in "Indian Rules & Regulation" section of this book) from a gazetted officer.
- (2) **2 copies of recent passport size (3 x 4 cms) photographs** duly signed by you on the front side.
- (3) Examination fees in the form of **Bank Draft (DD) drawn from a SBI branch** of appropriate amount.
- (4) **Personal particulars** (4 copies) in the prescribed proforma (find the proforma in "Indian Rules & Regulation" section)

- (5) An **attested copy of birth certificate or School Leaving certificate** as a proof of your age (the minimum age requirement to appear for the examination is 12 years)

After the declaration of the result, a copy of the result and your "Personal particulars" will be forwarded by the Wireless Monitoring Station to the WPC Wing of the Ministry of Communications, New Delhi. The WPC Wing, New Delhi will then inform the concerned Department of the Ministry of Home Affairs for a 'Security Clearance/Police Verification'. After the police verification report is received with a clearance, the WPC Wing will write to you that you will be awarded an "Amateur Wireless Telegraph Station Licence" on payment of the requisite "Licence fee". Remember that '**Examination Fee**' and '**Licence fee**' are different and the '**Licence fee**' should be sent only when asked for. This time, the mode of payment is same as above, but you have to send it directly to:

**The Assistant Wireless Adviser to the Govt. of India,**  
**WPC Wing,** Ministry of Communications,  
Amateur Radio Section,  
Dak Bhawan, Parliament Street,  
New Delhi-110 001

## B. Different grades of licencing examinations & licences

(1) **Restricted Grade Amateur Station Operator's Licence** (if you pass Restricted Grade licensing Examination): Permits **short distance terrestrial communication** using a power output of **10 Watts** (dc input power) in the Very High Frequency (VHF) & Ultra High Frequency (UHF) bands. The frequencies allocated in these bands ranges from **144 to 146 MHz** and **434 to 438 MHz**. Modes of communication allowed are: **Radio Telephony**(Voice) using **Amplitude Modulation (AM)**, **Single Side Band (SSB)**, SSB Suppressed Carrier, SSB reduced carrier and **Frequency Modulation (FM)**. **It is advisable not to go for this Grade of licence because communication is limited to a very short distance** (a typical possible range may be 35 km only depending on the height of the antenna or the type of terrain). **This type of licence is useful in a place where there are large number of ham radio operators.**

(2) **Grade II Licence** (if you pass Grade-II licensing examination): Permits **worldwide long distance communication** in AM, SSB, FM using a power output of **50 watts** in different allotted **short wave bands (high frequency-HF bands ranging from 1.8 to 30 MHz)** including the **VHF/UHF bands** mentioned above. **But entitlement for authorization of voice communication (radio telephony) is on the basis of providing proof of having made 100 contacts with other amateur radio stations using Morse Code (Called Continuous Wave-CW communication).** This means that you have to send back your original licence to the WPC wing for "**Voice endorsement**" along with the photocopies of your log book (see Rules & Regulation Section).

(3) **Grade-I:** (if you pass Grade-I licensing examination): Power output is **150 watts** in short waves (in the allotted HF bands), **25 watts in VHF & UHF** (Ultra High Frequency). An additional UHF spectrum from 1260 to 1300 MHz including a range

of frequencies in Super High Frequency (SHF: 3300-3400 & 5725 -5840 MHz) spectrum is available to this category of licensees. With this licence **you can directly use voice** including Morse Code. Other advanced modes like **Radio Tele-Typing (RTTY)**, **Amateur Radio Teleprinting Over Radio (AMTOR)**, **Packet Radio (-an advanced technique of digital data communication through computer connected to a wireless transceiver)**, **PSK31** (the latest digital communication mode in which a computer equipped with a sound-blaster card can be directly connected to a wireless transceiver for data reception and transmission), **Amateur Television (ATV using Slow Scan Telecast: SSTV)** are also allowed. You are also permitted to work amateur radio communication satellites with this licence.

**(4) Advanced Grade:** Same as Grade-I licence but allowed to use **400 watts** of power in selected sub-bands. **This is the highest grade licence in India.** Every ham radio enthusiast in India aspires to get it.

## Practical Test

There is a practical test on Morse Code sending and receiving (except for Restricted Grade Licence where this test is not required). This is a 10 minutes duration test to examine the candidates proficiency in sending and receiving Morse Code. To learn Morse code, a Morse Code Practice Oscillator can be assembled along with a Morse Key and a Morse Code learning Cassette can be found useful (See Morse Code learning Section of this book).

## C. The Indian Wireless Telegraphs (Amateur Service) Rules, 1978

**GOVERNMENT OF INDIA  
MINISTRY OF COMMUNICATIONS  
(WPC Wing)**

### Notification

#### The Indian Wireless Telegraphs (Amateur Service) Rules, 1978

**G.S.R No. 1499/78-** In exercise of the powers conferred by section 4 and section 7 of the Indian Telegraph Act, 1885 (13 of 1885), the Central Government hereby makes the following rules for the conduct of wireless telegraphs in the amateur service, established, maintained, and worked by persons licenced under the said Act.

#### **1. Short title and commencement**

- (1) These rules may be called the Indian Wireless Telegraphs (Amateur Service) Rules, 1978.
- (2) They shall come into force on the 1st January, 1979.

#### **2. Definitions**

In these rules, unless the context otherwise requires-

- (a) 'Act' means the **Indian Telegraph Act, 1885** (13 of 1885);

- (b) **‘Amateur service’** means a service of self training, inter-communication and technical investigations carried on by amateurs that is, by persons duly authorized under these rules interested in radio technique solely with a personal aim and without pecuniary interest; ‘amateur station’, and ‘station’ shall have the meaning respectively assigned to them in the Convention;
- (c) **‘Convention’** means the **International Telecommunication Convention**, Malaga-Torremolinos, 1973, for the time being in force and the Radio Regulations and the Additional / Radio Regulations annexed thereto but does not include any portion of the said Convention or Regulations regarding which the Central Government makes any reservation;
- (d) **‘Licence’** means a licence granted under section 4 of the Act for an amateur wireless telegraph station.

### 3. Necessity for licence

No persons shall establish, maintain and work an amateur wireless telegraph station, except under and in accordance with the terms and conditions of an appropriate licence under these rules.

### 4. Categories of licence

There shall be five categories of licences, namely :

- (i) Advanced Amateur Wireless telegraph Station Licence
- (ii) Amateur Wireless Telegraph Station Licence, Grade - I
- (iii) Amateur Wireless Telegraph Station Licence, Grade - II
- (iv) Restricted Amateur Wireless Telegraph Station Licence
- (v) Short Wave Listener's Amateur Wireless Telegraph Station Licence.

### 5. Eligibility for Licence

- (1) A licence may be granted subject to such conditions contained in Annexure I to these rules
  - (i) to a person-
    - (a) who is **a citizen of India;**
    - (b) who is **not less than 18 years of age;**
    - (c) who qualifies the Amateur Station Operator's Examination for the award of licence or holds either of the following certificate of proficiency, namely:
      - (i) Radio-communication Operators’ General Certificates;
      - (ii) First or Second Class Telegraph Operators’ Certificates:
 

Provided that the holder of a Special Radio Telegraph Operator's Certificate may also be considered eligible for the award of Amateur Wireless Telegraph Station Licence Grade II.
      - (iii) To a bonafide amateur radio society, club, a school, college, institute or university in India, which has the aim of participating in the 'amateur service': Provided that the licence shall be issued in the name of an authorized official of the society, club, school, college, institute or university in India, holding a category of licence appropriate to the transmission to be conducted by the station, including amateur radio beacon transmissions.
- (2) Notwithstanding anything contained in sub-clause (b) of clause (i) of sub-rule (1), the central government may grant, to bonafide experimenters between the ages of

14 and 18 years, Amateur Wireless telegraph Station Licence, Grade I and to those between the ages of 12 and 18, Amateur Wireless Telegraph Station Licence, Grade II or Restricted Amateur Wireless Telegraph Station Licence or Short Wave Listeners' Amateur Wireless Telegraph Station Licence: Provided that the application for the grant of such licences shall be accompanied by a certificate from the head of the educational institution, recognized by a board or university in India, attended by the applicant or from his legal guardian that the applicant is interested in and competent to conduct experiment in wireless telegraphy.

- (3) Notwithstanding anything contained in sub-clause (c) of clause (i) of sub-rule (1), the Central Government may recognize, subject to any conditions it may prescribe from time to time, such other Radiotelegraph Operators' Certificates or Amateur Station Operators' Certificate as are issued by a competent authority in India or any other country as equivalent to qualifications referred to in aforesaid sub-rule, for the purpose of grant of a licence under those rules.

## **6. Application for licence**

- (a) an individual, or  
(b) an amateur radio society or club or a school, college or an institute or an university in India  
-shall be made to the central government in Annexure II or Annexure III respectively to these rules, together with all the subsidiary forms and documents duly filled in and completed in all respects.

## **7. Eligibility for admission to Amateur Station Operator's Examination**

No person shall be eligible for admission to an examination for the grant of licence unless-

- (a) such a person fulfils the provisions contained in sub-clause (a) of clause (i) of sub-rule (1) and either sub-clause (b) of clause (i) of sub-rule (i) or sub-rule (2) of rule 5;  
(b) such person pays the fees on the following scale, namely:
- |  |           |
|--|-----------|
| (i) Advanced Amateur Station Operator's Examination  | Rs. 25.00 |
| (ii) Amateur Station Operator's Grade I Examination  | Rs. 20.00 |
| (ii) Amateur Station Operator's Grade II Examination and Restricted Wireless Telegraph Station Examination | Rs. 10.00 |
- (c) a period of at least one month has elapsed since he last appeared in an examination and failed.

## **8. Examinations**

- (1) The examinations for the grant of a licence shall be held at a place and on a date as may be notified by the Central Government from time to time.  
(2) An application for licence in Annexure II to the rules shall be submitted not later than the 15th of the month preceding that in which it is desired to take the examination.  
(3) Any person admitted to the examination and found guilty of impersonation or of submitting fabricated documents or documents which have been tampered with or of making statements which are incorrect or false or of suppressing material information or of using or attempting to use unfair means in the examination hall or otherwise resorting to any other irregular or improper means for obtaining admission to the examination may, in addition to rendering himself liable to

criminal prosecution, be debarred either permanently or for a specified period from appearing in any of the examinations held for the award of licence under these rules: Provided that no order under this sub-rule shall be made unless the person concerned has been given a reasonable opportunity for making a representation against the action proposed to be taken.

- (4) If any person is found guilty of any malpractice referred to in sub-rule (3) after the grant of a licence to such person, the central government may, in addition to prosecuting him cancel the licence so given:

Provided that the central government may, pending the cancellation of the licence, suspend or endorse such licence:

Provided further that no order under this sub-rule shall be made unless the person concerned has been given a reasonable opportunity for making a representation against the action proposed to be taken.

## **9. Grant of Licence**

Every category of licence shall be in the form set out in Annexure III to these rules.

## **10. Observance of conditions of licence, Convention and rules under the Act**

- (1) Every licenced amateur wireless telegraph station shall be established, maintained and worked in accordance with:

(a) the conditions contained in Annexure I to these rules;

(b) the provisions of the Convention;

(c) the rules made by the Central Government under section 7 of the Act for the conduct of wireless telegraphs in so far as they are applicable.

- (2) Notwithstanding sub-rule (1) the Central Government may modify, vary, cancel or revoke any of the conditions of licence contained in the said Annexure I at any time either by specific notice in writing to the licensee, or by means of a general notice published in the Official Gazette or in a newspaper published in New Delhi.

- (3) The licensee shall at his own expense, give effect to any variations in the conditions of licence,

## **11. Period of validity**

A licence granted under these rules shall be issued for a period of 2 years or 5 years, as the case may be, commencing on the date of issue of the licence and expiring on the last day of the month preceding the month of issue.

## **12. Fee for licence**

- (1) A licence fee on the following scale shall be paid to the Central Government on receipt of instructions from that Government and in the manner directed by it -

---

**Category of licence**

Fee for 2 years   Fee for 5 years

(i) Advanced Amateur Wireless Telegraph Station Licence	Rs.50/-	Rs.125/-
(ii) Amateur Wireless Telegraph Station Licence, Grade I	Rs.40/-	Rs.100/-
(iii) Amateur Wireless Telegraph Station Licence, Grade II; Restricted Amateur Wireless Telegraph Station Licence;	Rs.25/-	Rs.60/-
(iv) Short wave Listener's Amateur Wireless Telegraph Station Licence	Nil	

The licence fee shall not be refundable on ground of licensee's inability to establish or make use of the licensed amateur wireless telegraph station or for adjustments towards higher category of licence.

(2) No holder of a licence shall be entitled to a refund of fees paid therefore on the ground of his inability to establish or make use of the licensed amateur station.

### 13. Authorized frequency bands, power and emission

A holder of licence shall use, as appropriate to the licence, such frequency bands, power and classes of emission as are set out in Annexure V of these rules:

Provided that the central government may by special or general order make changes in the usage of frequency bands, power and types of emission where that Government is satisfied, that it is expedient to do so keeping in view, among others, the provisions of the convention need for enforcement of better technical standards in respect of equipment and national and international radio interference pattern.

### 14. Renewal of licence

- (1) On the expiry of the validity of a licence, it may be renewed for a period of two or five years, as the case may be, if the licensee-
- (a) makes an application for renewal, not earlier than 2 months but before the date of expiry;
  - (b) has actively operated an amateur wireless telegraph station during the validity of his licence and provides a certificate to the effect that he has made contacts with other amateur stations on at least 40 occasions per year, and in case of short wave listener, has intercepted amateur station on at least 40 occasions per year;
  - (c) Pays, a fee on the following scale, namely:

Category of licence	<u>Fee for: 2 years/5 years</u>	
(i) Advanced Amateur Wireless Telegraph Station Licence	Rs.50/-	Rs.125/-
(ii) Amateur Wireless Telegraph Station Licence,	Rs.40/-	Rs.100/-

Grade I		
(iii) Amateur Wireless Telegraph Station Licence, Grade II; Restricted Amateur Wireless Telegraph Station Licence;	Rs.25/-	Rs.60/-
(iv) Short wave Listener's Amateur Wireless Telegraph Station Licence.	Nil	

---

- (2) The licence fee shall not be refundable on ground of licensee's inability to establish or make use of the licensed amateur wireless telegraph station or for adjustments towards higher category of licence.
- (3) The document showing the renewal of licence issued by the Central Government shall be kept along with the licence to which it refers.
- (4) It shall not be obligatory for the Central Government to issue a notice that the licence is due for renewal.

### **15. Surcharge for late renewal**

In case the holder of licence does not apply for its renewal prior to the date of expiry of the licence referred to in sub-rule (1) of rule 14, he may apply for the renewal of licence subsequently also but within a period of two years after the date of expiry of the licence on payment of a surcharge at the rate of Rs. 10/- for every half year or part thereof. The licence in such a case, shall be renewed from the date of expiry of licence.

### **16. Register for wireless telegraphy apparatus**

Every licensee shall maintain a register in respect of all wireless telegraphy apparatus established, maintained and worked by him at the amateur station in the form set out in Annexure VI of these rules.

### **17. Location of Amateur Station**

The location of the amateur station shall be specified in the licence along with the usual residence of the licensee endorsed therein and it shall be operated only from the place so fixed.

Provided that the central government may permit the change of location if the licensee applies for it in writing giving particulars of the change and submits the licence for endorsement, and pays a fee of rupees five.

### **18. Portable and mobile amateur station**

The central government may in addition to an amateur station licensed for a specified location issue a special authorization to establish, maintain and work an amateur station as a mobile station installed on board a motor vehicle or as a portable station or for the purpose of exhibiting the operation of amateur station at jamborees or for specific technical investigations in radio if -

- (i) Application for such authorization is made at least 10 weeks in advance indicating, amongst other, the period for which the authorization is required, area of operation and the purpose;

- (ii) The applicant holds an Advanced Amateur Wireless Telegraph Station Licence or an Amateur Wireless Telegraph Station Licence Grade I;
  - (iii) The applicant pays an additional fee of Rs. 10.
- (2) The special authorization shall, in addition to the conditions specified in rule 10, be subject to conditions, namely:
- (i) The special authorization shall not be issued for a period more than 90 days and may be extended for a further period of 90 days on request and on payment of fee of Rs.10/-;
  - (ii) The licensee's amateur station at the fixed location and the mobile station shall not communicate with each other;
  - (iii) The suffix 'MO' shall be added to the call-sign already authorized to the licensee, such call-sign shall be followed by the location of the station;
  - (iv) such other conditions as the central government may determine from time to time.
- (3) The special authorization may be withdrawn or the conditions contained therein varied at any time by the central government.

### **19. Amateur Station on board ship**

- (1) Without prejudice to rule 17, the Central Government may on receipt of an application authorize establishment, maintenance and working of an amateur station on board a ship registered in India. Applications for such authorization shall be accompanied by a written approval of the master or owner of the ship concerned.
- (2) The establishment, maintenance and working of amateur station on board ships shall, in addition to the conditions specified under rule 10, be subject to such other conditions as the Central Government may determine from time to time and such conditions, among others, shall include the following, namely:
  - (i) The amateur station on board ship shall be operated only while the ship is in international waters or Indian territorial waters. Its operation within the territorial waters of another country shall be in conformity with laws and regulations of the country concerned.
  - (ii) It shall not be operated whilst the ship is in any harbour in India;
  - (iii) The call-sign allotted to such stations shall have suffix 'MS' followed by the call-sign of the ships in case of radiotelegraphy/official name of the ship in case of radiotelephony.
  - (iv) The amateur station on board a ship shall be independent of ship radio communication, radio navigation and other safety services radio equipment and shall be operated in such a manner as not to cause harmful interference to these services of the ship. The amateur station shall have source of electrical energy independent of the ship station and shall also be electrically independent of it.
  - (v) The amateur station on board a ship shall discontinue operation at any time on request of an officer of the Central Government, the master or radio officer of the ship or any land station.

### **20. Loss and Issue of Duplicate of Licence and Document showing the Renewal of Licence**

- (1) A person whose Licence or the document showing the renewal of licence has been lost, mutilated or destroyed shall notify the same to the central government. An

application in Annexure VII of these rules for the duplicate shall be made to the central government embodying a statement of the circumstances involved in the loss, mutilation or destruction of the licence or the document showing the renewal of licence for which a duplicate is required. If the licence or the document showing the renewal of licence has been lost, the applicant must state the circumstances in which it was lost and that reasonable search has been made for it, and further that in the event it be found, either the original or the duplicate shall be returned for cancellation. The mutilated licence or the document showing the renewal of licence for which the duplicate is required should be forwarded along with the application for cancellation.

- (2) The central government may issue duplicate copy of any licence or the document showing the renewal of the licence and the following charges shall be levied for such issue:
- (i) For duplicate of licence - Rs. 10
  - (ii) For duplicate of the document showing the renewal of licence- Rs. 5

### **21. Revocation of licence**

- (1) The central government may, at any time, revoke the licence-
- (i) On the breach of any of the conditions of licence contained in Annexure I; or
  - (ii) In default of payment of any fees payable under these rules;  
Provided that, before revoking a licence, the licensee shall be given a reasonable opportunity of making a representation against the action proposed to be taken.
- (2) The licensee shall not be entitled to any compensation arising out of revocation of his licence nor will any part of the fees paid for the licence shall be refunded for the period a licence stands revoked.

### **22. Transfer of licence**

A licence shall not be transferable:

Provided that the central government may permit the transfer of a licence granted to an authorized official of an amateur radio society or club or a school, college or an institute or an university in India in favour of his successor if such successor holds a category of licence appropriate to the transmissions to be conducted by the amateur station.

### **23. Operation of licenced amateur station**

No person other than the licensee shall be permitted to operate the licensed amateur station:

Provided that -

- (a) In the presence of the licensee himself, the station may be operated by another person holding a valid licence of comparable or higher category. The licensee, however, shall be personally responsible for the observance of these rules as if he operates the station.
- (b) In case of a licence issued to an authorized official of an amateur radio society, club, school, college, institute or university in India, the station may be operated by-
  - (i) a person who holds a licence equivalent or of higher category;

(ii) a person who holds a lower category of licence, where he operates the station on the frequency bands, emissions and power allocated to his category. In each of the cases aforesaid the licensee shall be responsible for the observance of this rule.

#### **24. Surrender of licence**

A licence which is revoked or which has become invalid and licensee does not desire to renew it shall be surrendered to the central government for cancellation and record.

#### **25. Dual holding of licence**

No person shall be granted more than one licence at the same time: Provided that the central government may exempt a person, holding a licence in his name for amateur radio society or a school, college or an institute or an university in India, from the operation of this rule.

#### **26. Admission of foreign nationals in examination and grant of licence**

- (1) Notwithstanding anything contained in these rules the central government may, subject to such terms and conditions as it may impose from time to time, admit a person, who is not a citizen of India, to an examination for the grant of a licence or grant him a licence if otherwise qualified.
- (2) The conditions under sub-section (1) shall, among others, include the following, namely:
  - (i) The country of which the applicant is citizen, grants reciprocal facilities to Indian nationals:  
Provided that it shall not apply where the central government considers that reciprocal facilities are not necessary;
  - (ii) The applicant is above the age of 18 years.
  - (iii) The applicant is holder of an appropriate category of amateur station operator's certificate or licence issued by a competent authority in any other country and recognised by the central government.
  - (iv) The licence under this rule shall be initially granted for a period of one year or for the period of validity of visa, for which the applicant's passport is endorsed, whichever is less, on payment of a proportionate licence fee as prescribed in Rule 12 subject to a minimum of fees payable of one year.

#### **27. Penalty for breach of these rules**

Any breach of these rules, other than a breach, which is an offence under section 20 or 21 of the Act, shall be punishable with fine, which may extend-

- (i) when the person is licenced under the Act, to Rs.1000 and in the case of continuing breach a further fine of Rs.200 for every day after the first during the whole or any part of which the breach continues;
- (ii) when a servant of the person so licenced or another person is punishable for the breach one fourth of the amounts specified in clause (i).

#### **28. Repeal and saving**

- (1) On the commencement of these rules, the Indian Wireless Telegraphy (Amateur Service) Rules 1958, shall cease to be in force,

- (2) Notwithstanding such cesser-
- (a) where before such commencement any person had passed the Amateur Station Operators Certificate Grade I or Grade II Examination, such person shall not be required to pass any such examination under these rules;
  - (b) where, before such commencement any person was granted Amateur Wireless Telegraph Station Licence Grade-I, or any such Licence was renewed and the period for which such Licence was granted or renewed extends beyond the commencement of these rules, then, such Licence shall continue to be in force for the period specified in the licence.

## Annexure I

### **CONDITIONS FOR THE CONDUCT OF AMATEUR WIRELESS TELEGRAPH STATION**

[See rules 5 & 10]

#### **1. Use of the Amateur Station**

- (1) The amateur station shall be used as part of self-training, intercommunication and technical investigations in radio techniques solely with a personal aim and without pecuniary interest:

Provided that when the station is licensed to an amateur radio society or club, or a school, college or an institute or a University, the use of the station shall be confined to technical investigations and training in radio communication techniques without pecuniary interest.

- (2) The station may also be used for the purpose of receiving transmissions in the standard frequency service to facilitate operation of the station within the authorized frequency bands.
- (3) Except as provided in these rules, the licensee shall not assign, under-let or otherwise dispose of or admit any person to participate in the benefits of the licence.

#### **II. Messages**

- (1) (a) Radio communications may be exchanged with other stations similarly authorized. The amateur stations are forbidden to communicate with amateur stations of countries whose administrations have notified the International Telecommunication Union of their objection to such radio communication.
  - (b) Transmissions shall be made in plain language and limited to messages of a technical nature relating to tests and to remarks of personal character (excluding business affairs or transactions) in which the licensee, or the person with whom he is in communication, are directly concerned and for which, by reason of their unimportance, recourse to the public telecommunication service is not justified.
  - (c) Special recordings for reproducing sinusoidal tone or tones within the audio frequency spectrum that may be either constant or steadily changing in frequency may be used.
- (2) The licensee is forbidden to transmit-

- (a) Messages like the reproduction of broadcast programmes or tape recordings or transmissions of entertainment value or music;
  - (b) False or misleading calls, or signals, news, advertisements, communications of business, statements on topics of political or industrial controversy;
  - (c) Superfluous signals or any matter which is indecent or of obscene character or of a seditious tendency or which is grossly offensive or such as is likely to arouse racial, religious, or communal animosity; and
  - (d) Messages for pecuniary reward or any messages for, or on behalf of third parties;
- (3) Notwithstanding clause (a), sub-condition (1) and clause (d), sub-condition (2) the licensees in case of failure of normal telecommunication facilities, are permitted to handle third party messages, pertaining to natural calamities such as earthquake, flood, cyclones and wide spread fires, originating from and addressed to a competent civil authority namely, (a) district magistrates or deputy commissioners or collectors of the district and (b) any other officer authorized by authorities mentioned at (a) above. The licensee shall inform by letter addressed to the licensing authority regarding the use of his amateur station for such purposes on each such occasion.

### **III. Frequencies, Emission and Power**

The amateur station shall be operated on frequencies that are within the frequency bands authorized to respective categories of licences under rule 13 and on such classes of emissions and power not exceeding that specified in the said rule.

### **IV. Frequency control and measurement**

- (1) The transmitting apparatus shall be tuned as accurately as possible to ensure that no energy is radiated on any frequency outside the limits of the authorized frequency bands.
- (2) The licensee shall have at the licensed amateur station a reliable frequency measuring equipment to verify, each time the frequency of the transmitter is changed and whenever it is necessary to check the transmitted frequency that emissions are within the authorized frequency bands. The licensee shall take all steps necessary to maintain the accuracy of the frequency measuring equipment.

### **V. Non-Interference**

- (1) The amateur station shall be so designed, constructed, erected, maintained and worked as not to cause interference with any wireless telegraph service functioning, within or without India, in accordance with the provisions of the convention or the wireless signaling between any fixed, land or mobile stations of Indian land, naval or air force or between such stations and any station abroad:

Provided that in the event of interference being caused by the station the licensee shall discontinue or restrict transmissions, pending adjustment of the equipment, on request from-

- (a) The Central Government; or
  - (b) Any land station.
- (2) The licensee shall deploy all necessary means to ensure that the radiated frequency is free from harmonics, key clicks, hum and other forms of spurious emissions.
  - (3) The licensee shall ensure that the transmitter is not over modulated.

(4) The use of class B emissions (damped waves) is forbidden.

## **VI. Log (Diary of the radio service)**

(1) A chronological record of all transmissions emanating from or received at the amateur station shall be kept in bound book (not loose leaf) showing the following:

- (a) Date and time of each transmission;
  - (b) A summary of the communications exchanged;
  - (c) A brief description of the experiments and tests undertaken;
  - (d) The call-sign of station or stations with which messages have been exchanged, times of establishing and terminating communication with each station and the frequency and type of emission employed in each case;
  - (e) Time of opening and closing down the amateur station;
  - (f) In case of portable or mobile amateur station the particulars of temporary location.
- (2) All times in the log shall be stated in the Indian Standard Time.
- (3) No gaps shall be left between entries in the log and they shall be made and initialed at the time of receiving and transmitting.
- (4) In case the station is operated by a person other than the licensee (see rule 23), the licensee shall ensure that log is signed by that person indicating his name, call-sign and licence number.
- (5) Licensee shall preserve the log for a period of one year from the date of last entry therein before it is destroyed:  
Provided that no log shall be destroyed for such further period as the Central Government may direct.
- (6) The form of log is shown in the Table attached to these conditions.

## **VII. Wireless Telegraphy Apparatus**

- (1) The amateur station shall be equipped for reception as well as transmission except in the case of Short Wave Listeners Amateur Wireless Telegraph Station Licence when it shall be equipped for the former only.
- (2) The wireless telegraphy apparatus and other accessory equipment used or intended to be used by the licensee shall be so arranged as not to endanger the safety of licensee or other persons.
- (3) The wireless telegraph apparatus shall be kept in a safe condition and housed in such manner as to preclude access to unauthorized persons.
- (4) The transmitter shall be of a type that has frequency stability comparable to that of a crystal control.
- (5) Meters of standard accuracy shall be installed to measure the D.C. power input to the anode circuit of the final radio frequency stage of the transmitter.
- (6) The aerial used or intended to be used shall be so erected, fixed, or placed as not to cross above or fall on to any power, telegraph or telephone line. If required, the licensee shall take necessary steps to guard, to the satisfaction of the owner or owners concerned, so as to prevent any damage being done in the event of a break occurring in the aerial. The aerial installation shall not cause hazard to flight of aircraft and their heights shall be within the limits specified by the Director General of Civil Aviation in India from time to time. The licensee shall, if so directed, install and maintain beacon lights on and paint the mast of the station at his own cost.

## **VIII. Secrecy of Correspondence**

If any message which the licensee is not entitled to receive is, nevertheless received, the licensee shall not make known or allow to be made known its contents, its origin or destination, its existence or the fact of its receipt to any person (Other than duly authorized officer of the Central Government or a competent of legal tribunal) and shall not reproduce in writing, copy or make any use of such message or allow the same to be reproduced in writing, copied or made use of.

## **IX. (1) General Radiotelegraph and Radiotelephone Procedure**

- (a) Before transmitting, the station shall take precautions to ensure that its emissions will not interfere with transmissions already in progress. If such interference is likely the transmission shall not commence till there is an appropriate break in the communications in progress.
- (b) The call sign endorsed in the licence shall be sent for identification at the beginning and at the end of each period of transmission. When the period of transmission exceeds 10 minutes the call sign shall be repeated. Licensee shall not make transmission without identification or with false identification.
- (c) Prolonged calls and transmissions shall be avoided.
- (d) When it is necessary to spell out call sign, certain expressions, difficult words, abbreviations, figures etc., the phonetic alphabet and figure code given in the Convention shall be used.

### **(2) Call and Reply Procedure**

- (a) The call shall consist of The call sign of the station called not more than three times; The word DE (in case of radiotelegraphy) and the words 'This is' (in case of radiotelephony) and the call sign of the calling station, not more than three times.
- (b) The reply to call shall consist of the call sign of the calling station, not more than three times; The word DE (in case of a radiotelegraphy) and the words 'This is' (in case of radiotelephony) the call sign of the station called, not more than three times.
- (c) The call may be sent three times at intervals of two minutes; thereafter it shall not be repeated until an interval of 10 minutes during which the operator shall list in the frequency band in which the call has been made.
- (d) In case of general call to all stations the signal 'CQ' (in case of radiotelegraphy) and the words 'Hello all stations' or the signal 'CQ' (in case of radiotelephony) shall replace the call sign of the station called in the calling procedure.

### **(3) End of Transmission and Work**

- (a) Transmissions of a message shall be terminated by the signal AR (in case of radio, telegraphy) and by the word 'Over' (in case of radiotelephony).
- (b) The end of work between two stations shall be indicated by each of them by means of the signal VA (in case of radiotelegraph) and by the word 'OUT' (or VA spoken as Victor Alfa) in case of radiotelephony.

### **(4) Tests:**

- (a) When it is necessary to make test signals either for the adjustment of a transmitter or a receiver or for any experiment, such signals shall not be continued for more than 3 seconds and shall be composed of series of VVV followed by the call-sign of the station emitting the test signals. In case of radiotelephony series of VVV shall be replaced by the figures 1,2,3,4... spoken in the figure code.
- (b) For tests exceeding 30 seconds an artificial aerial shall be used.
- (c) Emission of carrier wave is forbidden unless such wave is subjected to intelligible modulation.

**X. Inspection**

- (1) Any officer authorized by the Central Government in that behalf in writing by them, may at all reasonable times enter the station solely or jointly with any other person or persons for the purpose of inspecting and may inspect, examine or test any apparatus conduct of such inspections and tests and make available the licence, the station log or other records for examination by the inspecting officer.
- (2) The licensee when called upon to do so by the Central Government shall arrange to forward the licence, the logbook, or any other record or data for examination by that Government.

**XI. Powers to take possession of the Amateur Station and to order interception of message:**

- (1) On the occurrence of any public emergency, or in the interest of the public safety, the Central Government or a State Government or any officer specially authorized in this behalf by the Central Government or a State Government may, if satisfied that it is necessary or expedient so to do, take temporary possession (for so long as the public emergency exists or the interest of the public safety requires the taking of such action) of the Amateur Station.
- (2) On the occurrence of any public emergency or in the interest of the public safety, the central government or a State Government or any officer specifically authorized in this behalf by the Central Government or a State Government may, if satisfied that it is necessary or expedient so to do in the interests of the sovereignty and integrity of India, the security of the State, friendly relations with foreign states or public order or for preventing incitement to the commission of an offence, for reasons to be recorded in writing, by order, direct that any message of class of messages relating to any particular subject, shall not be transmitted or received or shall be intercepted by the station or shall be disclosed to the Government making the order or an officer thereof mentioned in the order.
- (3) The licensee shall not be entitled to any compensation in respect of the exercise of the powers conferred by sub condition (1) and (2) of this condition.

**XII.** The licensee shall indemnify the Central Government against all actions, claims and demands which may be brought or made by any person, body corporate or company in respect of any injury arising from any act licenced or permitted by the licence.

**XIII.** A copy of the Indian Wireless telegraphs (Amateur Service) Rules, 1978 shall be kept at the Amateur Station.

Table

[See Condition VI(6)]

### Specimen Form of Log

Sl. No. of Contact	Date	Time	Frequency & Type of Emission & power input to final stage (FEP)	Station Called by	Station heard or worked (RST)	Report Received (RST)	Time of Terminating QSO	Time of Record Experiment & tests /summary of communication	QSL Card (Sent/received)	Initials
--------------------	------	------	---	-------------------	-------------------------------	-----------------------	-------------------------	---	--------------------------	----------

Under the above rules, a licence may be granted, subject to certain conditions to a person, who is a citizen of India and not less than 18 years of age (subject to relaxation indicated at para 1 below) and who qualifies Amateur Station Operators's Examination Certificate of Proficiency issued by this Ministry i.e. (I) Radio Communication operator's General Certificate; (ii) First or Second Class Radio Telegraph Operator's Certificate; (iii) The holder of a special radio telegraph Operator's Certificate may also be considered eligible for the award of Grade II licence.

The following categories of licences are issued:

(The fees for examination are shown alongside)

- |  |          |
|--|----------|
| (i) <b>Advanced</b> Amateur Wireless Telegraph Station Licence             | Rs. 25/- |
| (ii) Amateur Wireless Telegraph Station licence <b>Grade I</b>             | Rs. 20/- |
| (iii) Amateur Wireless Telegraph Station Licence <b>Grade II</b>           | Rs. 10/- |
| (iv) <b>Restricted</b> Amateur Wireless Telegraph Station Licence          | Rs. 10/- |
| (v) <b>Shortwave Listener's</b> Amateur Wireless Telegraph Station Licence | Nil      |

The central government may grant to bonafide experimenters between the ages of 14 and 18 years, Amateur Wireless Telegraph Station Licence Grade I and to those between the ages of 12 and 18 years, Amateur Wireless Telegraph Station Licence Grade II, Restricted Amateur Wireless Telegraph Station Licence or Shortwave Listeners Amateur Wireless Telegraph Station Licence.

The examination for the award of various categories of Amateur Wireless Telegraph Station Licence are held at various Monitoring Stations of this ministry, as per the syllabus contained in the above mentioned rules. **A person desiring to appear in these examinations should apply on the prescribed application form (enclosed) to the nearest monitoring station along with the prescribed examination fee. In no case the application may be forwarded to WPC, Ministry of Communications, New Delhi.**

The examination fee varies from Rs. 10/- to Rs.25/- depending upon the category of examination. After a decision is taken to grant the licence, an additional fee of Rs. 25/- to Rs.50/- as the case may be, will be required towards the grant of licence. **The fees are required to be paid in the form of bank draft obtainable from any branch of the State Bank of India and drawn in favour of Pay & Accounts Officer (Headquarters), Department of Telecommunications, New Delhi 110001 (code 7687).**

The particulars of the venue and date, etc. of the examination will be communicated to the candidates by the officer-in-charge of the concerned monitoring station on receipt of the complete application form with requisite fee.

Following should accompany the application:

1. Nationality Certificate/Character Certificate in the prescribed proforma enclosed.
2. 2 copies of photograph duly signed on front side. The size of the photograph must be 3x4 cms.
3. Examination fees, in the form of bank draft, of the appropriate amount. The draft should be obtained from any branch of State bank of India and drawn in favour of **'Pay & Accounts Officer (Headquarters), Department of Telecommunications'**. It should be payable at State Bank of India, New Delhi Service Branch (Code No. 7687).
4. Result Sheet, duly filled in (in duplicate).
5. Personal particulars (in quadruplicate) in the prescribed proforma.

Annexure-II

**APPLICATION FROM AN INDIVIDUAL FOR A LICENCE  
TO ESTABLISH, MAINTAIN AND WORK AN AMATEUR  
WIRELESS TELEGRAPH STATION IN INDIA. (See rules 6 &  
8)**

1. Name (In Block letters):

.....  
(Last name) (First) (Middle)

2. Father's/Husband's Name and address : .....

.....

3. (a) Address (Present)

.....

.....

(b)Address (Permanent)

.....

.....

4. ( a )Date of Birth ( b )Place of Birth ( c )Nationality ( d )Occupation

5. (a) Category of Licence applied for (b) exact location of the Station

6. (a) If you are exempted from appearing in any part of the examination, give details of your qualifications

- (b) If you wish to appear for the qualifying examination, give the preferred centre and date of examination

Centre

Month of Examination

- (c) Do you hold any other licence earlier, if so give details

Licence No. \_\_\_\_\_ Call-sign, if any \_\_\_\_\_

(Duly filled in application form should be submitted to the concerned Wireless Monitoring Station only)

### **DECLARATION**

I hereby solemnly declare that the foregoing facts are true and correct and nothing is false therein and nothing material has been concealed therefrom. I also agree that in case any information given by me herein before is found false at a later date, the licence, if granted, will be cancelled.

I further solemnly give an undertaking that I will not either directly or indirectly divulge to any person, except when lawful authorized or directed to do so, the purport of any message which I may transmit or receive by means of any wireless apparatus operated by me or which may come to my knowledge in connection with the operation of said apparatus.

I have carefully read and understood the rules contained in the Indian Wireless Telegraphs (Amateur Service) Rules, 1978 and undertake to abide by them and observe the conditions of the licence. The licensed station shall not be made accessible to any unauthorized person at any time.

Signature of witness:

Signature of applicant

Name (in block letters)

Name (in block letters)

Address:

Date:

Date:

Place:

Note :

1. An attested copy of birth certificate or school leaving certificate must be accompanied along-with the application.
2. Enclose a certificate in support of nationality in the prescribed Performa, indicated in Appendix III from one of the officers listed therein.

### **Annexure-III**

### **APPLICATION FOR A LICENCE TO ESTABLISH, MAINTAIN AND WORK AN AMATEUR WIRELESS TELEGRAPH STATION BY AN AMATEUR RADIO SOCIETY OR CLUB OR A SCHOOL, COLLEGE OR AN INSTITUTE OR A UNIVERSITY IN INDIA (See rules 6 & 8)**

1. Name and address of the Amateur Radio Society/Club/School/Institute etc.

2. Particulars of authorized official of the Society/Club/School etc. in whose favour licence is desired

<u>Name</u>	<u>Designation</u>		
<u>Date of Birth</u>	<u>Place of Birth</u>	<u>Nationality</u>	<u>Occupation</u>

3. (a) Category of licence applied for (b) exact location of the station

4. Particulars of Amateur Wireless Telegraph Station Licence held by the authorized official

<u>Category of Licence</u>	<u>Licence No.</u>	<u>Date of Issue</u>
----------------------------	--------------------	----------------------

5. Particulars of the Amateur Radio Society or club, school etc.

(a) If registered, given its particulars:

(b) In case of school, college or institute, give the name of Board or University by which it is recognized.

(c) Give in brief its aims and objectives:

(d) If affiliated to any radio amateur organization, give its particulars:

(e) Give the names of office bearers:

(f) Mode of operation of the station including its normal hours of working :

6. Particulars of Apparatus to be used:

Category of Apparatus/ Manufacturer's name /Type No/ Frequency Range /RF power output/

Transmitter :

Receiver :

Frequency Measuring Device :

### DECLARATION

I hereby solemnly declare that the foregoing facts are true and correct and nothing is false therein and nothing material has been concealed therefrom. I also agree that in case any information given by me herein before is found false at a later date, the licence, if granted, will be cancelled.

I further solemnly give an undertaking that I will not either directly or indirectly divulge to any person, except when lawful authorized or directed to do so,

the purport of any message which I may transmit or receive by means of any wireless apparatus operated by me or which may come to my knowledge in connection with the operation of said apparatus.

I have carefully read and understood the rules contained in the Indian Wireless Telegraphs (Amateur Service) Rules, 1978 and undertake to abide by them and observe the conditions of the licence. The licensed station shall not be made accessible to any unauthorized person at any time.

Signature of witness:  
of applicant

Signature

Name (in block letters)

Name (in block letters)

Address:

Date:

Date:

Place:

Note :

1. An attested copy of birth certificate or school leaving certificate must be accompanied along with the application.
2. Enclose a certificate in support of nationality in the prescribed Proforma, indicated in Appendix III from one of the officers listed therein.
3. Attach a copy of the rules and regulations or constitution.
4. Attach the minutes of the relevant meeting.

### PERSONAL DETAILS OF THE APPLICANT

(To be submitted with **three extra copies** on separate sheet)

1. Full Name (In Block letters): \_\_\_\_\_

2. Date & Place of Birth: \_\_\_\_\_

3. Age: \_\_\_\_\_ Years \_\_\_\_\_ Months.

4. Height: \_\_\_\_\_ cm

5. Colour of: (i) Eyes \_\_\_\_\_ (ii) Hair \_\_\_\_\_

6. Complexion: \_\_\_\_\_

7. Any special peculiarities of mark: \_\_\_\_\_

8. Present Address: \_\_\_\_\_

9. Permanent home address: \_\_\_\_\_

10. Nationality: \_\_\_\_\_

11. Occupation (Major work  
or profession for which you  
receive money or activity  
which occupies the  
majority of your time) \_\_\_\_\_

12. Father's name and home address \_\_\_\_\_

(if dead, give last address)Aliases \_\_\_\_\_

if any: \_\_\_\_\_

13. Type of license applied for: \_\_\_\_\_

14. Proposed location of station: \_\_\_\_\_

(Details of house No., Street \_\_\_\_\_

No., Road No.) \_\_\_\_\_

Dated: \_\_\_\_\_

Signature of the applicant

(Full name giving expansion of initials)

### NATIONALITY CERTIFICATE

Certified that I have known Shri/Smt./Km. \_\_\_\_\_,  
Son/Daughter of Shri \_\_\_\_\_ for the last \_\_\_\_\_  
Years and that to the best of my knowledge and belief he/she bears a good moral  
character. He/She is of \_\_\_\_\_ nationality. He/She is not related to me.

Address: \_\_\_\_\_

Signature

#### NOTE:

This certificate should be from one of the officers listed below:

1. Gazetted Officers of Central or State Governments.

2. Members of Parliament or State Legislatures.
3. Sub-divisional Magistrate/Officer.
4. Tehsildars or Naib/Deputy Tehsildars, authorized to exercise magisterial powers.

ANNEXURE IV

[See rule 9]

**Licence No.**

**GOVERNMENT OF INDIA  
MINISTRY OF COMMUNICAITON**

**LICENCE TO ESTABLISH, MAINTAIN AND WORK AN AMATEUR  
WIRELESS TELEGRAPH STATION IN INDIA.**

Having satisfied, by examination or otherwise, that Shri .....  
possesses the requisite technical qualifications as prescribed under the Indian,  
Wireless Telegraphs (Amateur Service) Rules, 1978, the Central Government in  
exercise of the powers conferred under the authority of section 4 of the Indian  
Telegraph Act, 1885 (13 of 1885), hereby grant to him an  
to establish, maintain and work a wireless telegraph  
transmitting and receiving station, detailed below, during the term of period  
commencing on the day of the date hereof and terminating on the .....19  
when this licence becomes invalid unless renewed further by way of a  
document showing the renewal of Licence.

The licence is governed by the Indian Wireless Telegraphs (Amateur Service) Rules,  
1978, Particulars of the Station :

Location:                      Call-sign:  
Issued by the Government of India in the  
Ministry of Communication  
New Delhi :

Dated :

**Deputy/Assistant Wireless  
Adviser to the Govt. of India**

**in the presence of ..... Date .....**

**Signature of Licencee**

**Date .....**

**Latest amendment to the Indian Wireless Telegraph (Amateur Service) Rules,  
1978, vide Notification dated 4<sup>th</sup> October, 1985.**

In pursuance of the provisions of rule 13 of the Indian Wireless Telegraph (Amateur  
Service) Rules, 1978 the Central Government hereby authorises the following  
frequency bands, emission and power to the holder of Amateur Wireless Telegraph  
Station Licence. This supercedes the frequency bands, emission and power prescribed  
in the Annexure- V to the above said rules in pursuance to Notification No, R-  
11014/14/82-L.R. dated 23<sup>rd</sup> May, 1983.

ANNEXURE V

**Frequency bands, emission and power**



			<b>specified</b>
(d) <b>Advanced Amateur Telegraph Station Licence.</b>	1820-1860 kHz*	A1A, A2A, A3E,	150 Watts
<b>See Note (i) below</b>	3500-3700 kHz	H3E, R3E, J3E,	
	3890-3900 kHz	F1B, F2A, F3E,	
	7000-7100 kHz	F3C, A3C, A3F	
	14000-14350 kHz		
	18068-18168 kHz \$		
	21000-21450 kHz		
	24890-24990 kHz \$		
	28000-29700 kHz		
	144-146 MHz	} -do- }	50 Watts for terrestrial service. Amateur Satellite Service is permitted in the appropriate sub-bands in accordance with Radio Regulations and in those cases the maximum output RF power (e.i.r.p.) is 30 dbw.
	434-438 MHz @		
	1260-1300 MHz @ &		
	3300-3400 MHz @		
	5725-5840 MHz @		

\* On primary shared basis as per the relevant provisions of Radio Regulations.

\$ The authorisation is on non-interference and non-protection basis.

@ On secondary basis as per the relevant provisions of Radio Regulations.

& 1260-1270 MHz for Earth to space satellite service only.

The above authorisation is subject to site clearance as per the procedure prescribed by the Standing Advisory Committee on Radio Frequency Allocation (SACFA) as applicable.

Note: (i) Following sub-bands of frequencies are authorised with enhanced R.F. power to holder of Advanced Amateur Telegraph Station Licence

3520-3540 kHz	All emissions	400 Watts
3890-3900 kHz	as authorised	
7050-7100 kHz		
14050-14150 kHz		
14220-14320 kHz		
21100-21400 kHz		

(ii) For A3F emission, the transmission shall be restricted to call-sign of the station, location and other particular of the amateur station. They shall be limited to point to point test transmission employing a standard interlace and scanning with a bandwidth not more than 4 kHz.

- (iii) DC input power is the total direct current power input to the final stage of the transmitter.
- (iv) In case of Short Wave Listener's Amateur Licence, the holders are permitted to listen to all the bands authorised to Amateur Service.
- (v) The syllabus for the examination of the Restricted Amateur Wireless Telegraph Station Licence shall be same as per Part I of Amateur Station Operator's Grade II examination.
- (vi) The holder of Amateur Wireless Telegraph Station Licence, Grade II shall be entitled for authorisation of radio telephony emission on his providing proof of having made 100 contacts with other amateur stations using CW (Morse Code).

#### D. Syllabus of Amateur Station Operator's Certificate (ASOC) Examination for the award of Amateur Station Operator's Licence

The ham radio licensing examination is conducted to ascertain that the person going to be a ham radio operator is equipped with the knowledge and proficiency which is necessary to communicate using a wireless transceiver without causing interference to the other radio communication services. The course covers basic electronics and radio theories as well as the existing national and international rules related to amateur radio communication in radiotelephony (voice) and radio telegraphy (Morse Code). The person who wants to become a ham should at the same time be able to show his proficiency in Morse Code sending and receiving. The examination is conducted at the 22 Wireless Monitoring Stations (Annexure-I) located throughout the country. The examination is held for four different categories of licence. They are the :

- (1) **Advanced Grade Licence**
- (2) **Grade I Licence**
- (3) **Grade II Licence**
- (4) **Restricted Grade Licence.**

Anyone above 12 years of age can obtain Amateur Radio Station Operator's Licence after passing the examination/s mentioned above. **It is also possible to establish an Amateur Radio Club Station with a licensed ham in charge of it.**

The application form for Amateur Radio Station Operator's Certificate Examination can be obtained from :

**The Assistant Wireless Advisor to the Govt. of India,**  
Wireless Planning & Coordination (WPC) Wing, Amateur Radio Section,  
Ministry of Communications, Dak Bhavan, Parliament Street, New  
Delhi-110001

The application form can also be obtained from the Wireless Monitoring Station of the Ministry of Communications located nearest to your hometown. The filled-in Application Form along with all other necessary documents **should be sent to the Wireless Monitoring Station located nearest to your home town** or where you wish to appear for the examination.

# Syllabus

## Part-I

### Section I

Radio Theory and Practice (**Applicants holding degree in telecommunication, or electronics and electrical communication, or a degree recognized by the central government as equivalent to the above degree shall be exempted from appearing in SECTION I of the test**).

### Section II

National and International regulations applicable to the operation of amateur radio station and those relating to the working of station generally.

## Part II - Morse Code

### Section I

Morse code **receiving**.

### Section II

Morse code **sending**.

## Detailed Syllabus

### Amateur Radio Operator's Grade I & II Certificate Examination

## Part-I

### Section I : Radio Theory and Practice

#### Elementary electricity and magnetism

Elementary theory of electricity, conductors and insulators, units, Ohm's law, resistance in-series and parallel, conductance, power and energy, permanent magnets and electromagnets and their use in radio work; self and mutual inductance; types of inductors used in receiving and transmitting circuits, capacitance; construction of various types of capacitors and their arrangements in series and/or parallel.

#### Elementary theory of alternating currents

Sinusoidal alternating quantities- peak, instantaneous, RMS, average values, phase; reactance, impedance; series and parallel circuits containing resistance, inductance, capacitance; power factor, resonance in series and parallel circuits; coupled circuits; transformers for audio and radio frequencies.

#### Thermionic valves

Construction of valves; thermionic emission, characteristic curves, diodes, triodes and multi-electrode valves; use of valves as rectifiers, oscillators, amplifiers, detectors and frequency changers, power packs, stabilization and smoothing.

## **Elementary theory and construction of semiconductor devices**

Diodes and Transistors.

### **Radio receivers**

Principles and operation of TRF and super- heterodyne receivers, CW reception, receiver characteristics-sensitivity, selectivity, fidelity; adjacent channel and image interference; AVC and squelch circuits; signal to noise ratio.

### **Transmitter**

Principles and operation of low power transmitter; crystal oscillators, stability of oscillators.

### **Radio propagation**

Wavelength, frequency, nature and propagation of radio waves; ground and sky waves; skip distance; fading.

### **Aerials**

Common types of transmitting and receiving aerials.

### **Frequency measurement**

Measurement of frequency and use of simple frequency meters.

## **SECTION II : Radio Regulations**

(a) Knowledge of :

(i) the Indian Wireless Telegraph Rules, 1973; and

(ii) the Indian Wireless Telegraphs (Amateur Service) Rules, 1978.

(b) Knowledge of International Radio Regulations as relating to the operation of amateur stations with particular emphasis on the following:

**Designation of Emission,**

**Nomenclature of the frequency and**

**wavelength, Frequency allocation to amateur**

**radio service, Measures against Interference,**

**Interference and tests, Identification of stations,**

**distress and urgency transmissions, Amateur**

**Stations,**

**Phonetic alphabets and figure code.**

(c) Standard frequency and time signal services in the world.

(d) The following 'Q' codes and abbreviations which shall have meaning as assigned to them in the International Telecommunication Union (ITU) convention :

QRA, QRG, QRH, QRI, QRK, QRL, QRM, QRN, QRQ, QRS, QRT, QRU, QRV, QRW, QRX, QRZ, QSA, QSB, QSL, QSL, QSO, QSU, QSV, QSW, QSX, QSY, QSZ, QTC, QTH, QTR and QUM.

Telegraphic (Morse code) abbreviations: AA, AB, AR, AS, BT, C, CFM, CL, CQ, DE, K, KN, NIL, OK, R, TU, VA, WA, WB.

The written examination for Grade II licence is of one hours duration. The maximum number of marks is 100. **Candidates must secure at least 40 per cent in each section and 50 per cent in aggregate to pass.** The syllabus for Grade I licence is the same as that for Grade II licence, but the **written examination for Grade I licence is of two hours duration.** The maximum number of marks is 100 and candidates must secure at least **50 per cent in each section and 55 per cent in aggregate for a pass.**

## **Part II : Morse Code**

### **(a) Section I : Morse Receiving** (Speed: 5 words per minute)

The test piece will consist of a plain language passage of 125 letters, five letters counting as one word. Candidates are required to receive for five consecutive minutes at the speed of 5 words per minute from a double headgear headphone receiver, international Morse code signals from an audio frequency oscillator keyed either manually or automatically. A short practice piece may be sent at the prescribed speed before the start of the actual test. Candidates will not be allowed more than one attempt in each test. The test may be written in ink or pencil but must be legible. Bad handwriting and over-writing will render a candidate liable to disqualification. More than five errors will disqualify a candidate.

### **(b) Section II : Morse Sending** (Speed: 5 words per minute)

The test piece will consist of a plain language passage of 125 letters, five letters counting as one word. Candidates are required to send on an ordinary key for five consecutive minutes at the minimum speed of five words per minute. A short practice piece may be allowed before the actual test. Candidates will not be allowed more than one attempt in the test. Efforts should be made to correct all errors. However, more than five uncorrected errors will disqualify a candidate. The accuracy of signaling, correct formation of characters and the correctness of spacing shall be taken into account.

A candidate is required to pass both in Part I and Part II. In the case of candidates qualifying in Part I only, the licence shall be restricted to radiotelephone operations in the VHF ham band only.

## **Morse Code test for Grade I**

### **Receiving-**(Speed: 12 words per minute)

The test piece will consist of a plain language passage of 300 characters which may comprise letters, figures and punctuation (punctuation are indicated below). The average words shall contain five characters and each figure and punctuation will be counted as two characters. Candidates are required to receive for five consecutive

minutes at a speed of 12 words per minute. Other conditions are the same as applicable to Grade II Examination.

### **Punctuations**

Full stop, Comma, Semi-colon, Break sign (BT), Hyphen and Question mark.

### **Sending**-(Speed: 12 words per minute)

The test piece will be similar to Morse receiving test. Candidates are required to send for five consecutive minutes at a speed not less than 12 words per minute. Other conditions are the same as applicable to Grade II examination.

A candidate is required to pass both in Part I and Part II simultaneously.

## **Advanced Amateur Station Operators' Examination**

### **Part I-Written Test**

#### **(a) Section 1: Radio Theory and Practice**

In addition to the syllabus prescribed for Grade II Examination, following items shall be included in the syllabus of Advanced Amateur Station Operators' Examinations :-

- (i) **Motors and generators:** Elementary principles and construction of alternators, motors and generators.
- (ii) **Alternating current:** Construction of transformers, transformer losses, transformer as a matching device.
- (iii) **Measuring instruments:** Moving coil and moving iron meters, frequency meters.
- (iv) **Semiconductor devices and transistors:** Elementary principles of conduction and construction, symbols, biasing methods.
- (v) **Power supplies:** Half-wave and full-wave rectifiers, smoothing and regulation, bridge rectifier.
- (vi) **Modulation:** Principles of frequency modulation.
- (vii) **Transmitters and receivers:** Elementary principles of transmission and reception of facsimile and television signals, elementary principles of transmitters and receivers employing single side band.
- (viii) **Propagation:** Characteristics of ionosphere and troposphere. Properties of different reflecting layers, optimum working frequency, day and night frequencies.
- (ix) **Aerials:** Principles of radiation, aerials for different frequency bands including aerials for microwave.
- (x) **Space communications:** Elementary principles of communication via satellite.

## **(b) Section 2: Radio Regulations**

Syllabus is same as prescribed for Grade II Examination. The test is of 3 hours duration. The maximum number of marks is 100 and candidate must secure at least 50 per cent in each section and 60 per cent in aggregate for a pass.

### **Part II- Morse Code**

Syllabus is same as prescribed for Grade I Examination.

## **E. Question and Answer Section on Amateur Radio Rules & Regulations**

### **Q. What do you mean by 'Amateur Radio Service'?**

'Amateur Radio Service' is a two-way radio communication service available to persons who are licensed by the communication authority to carry out experimentation in the field of radio communication techniques. The Indian Wireless Telegraphs (Amateur Service) Rules 1978 defines 'Amateur Service' as "*a service of self training, inter-communication and technical investigations carried on by amateurs that is, by persons duly authorised under these rules interested in radio technique solely with a personal aim and without pecuniary interest*".

### **Q. What types of messages are forbidden to be transmitted from an amateur radio station?**

A ham radio operator is allowed to transmit in plain language (Morse Code, RTTY, Packet radio etc. included) and his message shall be of a technical nature related to tests, remarks of personal character which are not related to business affairs or transactions. He is forbidden to transmit:

- (i) Messages like the reproduction of broadcast programmes or tape recordings or transmissions of entertainment value or music.
- (ii) False or misleading calls, or signals, news, advertisements, communications of business, statements on topics of political or industrial controversy.
- (iii) Superfluous signals or any matter which is indecent or of obscene character or of a seditious tendency or which is grossly offensive or such as is likely to arouse racial, religious, or communal animosity; and
- (iv) Messages for pecuniary reward or any messages for, or on behalf of third parties (i.e. non-amateurs).

### **Q. Is third party communication allowed in India in 'Amateur Radio Service'?**

Third party messages originating from a non-amateur or meant for a non-amateur are not allowed in India, except in case of failure of normal telecommunication facilities

during earthquake, flood, cyclones, widespread fires or during any other disasters. Under such circumstances, a ham radio operator can handle third party messages pertaining to disasters. Such messages should originate from or addressed to a competent civil authority namely, (a) district magistrates or deputy commissioners or collectors of the district and (b) any other officer authorized by the authorities mentioned at (a) above.

### **Q. What is 'Secrecy of Correspondence'?**

If any message which the ham radio operator is not entitled to receive is, nevertheless received, the ham radio operator shall not make known or allow to be known its contents, its origin or destination, its existence or the fact of its receipt to any person (other than duly authorized officer of the central government or a competent legal tribunal) and shall not reproduce in writing, copy or make any use of such message or allow the same to be reproduced in writing, copied or made use of.

### **Q. What is a 'Ham Radio Net'?**

A ham radio net is a voluntary radio communication network formed under the initiative of a few hams which is maintained at scheduled time/times of the day (everyday or at scheduled days). The heart of the net is the 'net controller', who takes messages from the hams joining the net and pass it on to its respective destination. Different nets may have different objectives. For example '**Air NET India**' is the National Emergency Traffic (NET) net run by the **Amateur Radio Society of India (ARSI)**. This net is conducted everyday from 7:00 PM or 7:30 PM on **14.150 MHz ± QRM** to handle any emergency medical traffic, other emergency traffic and to check the radio wave propagation condition. But one of the main objectives of this net is to provide the facility to the Indian hams to establish contact between two hams. A ham 'X' can pass on the request to the 'net controller' regarding his willingness to contact a ham 'Y'. The 'net controller' then helps both the station to make the contact on a mutually decided frequency. So every active hams should have the habit of checking into this kind of net regularly.

### **Q. What is a distress call?**

A distress call is a call given from a ship, aircraft or vehicle indicating that the caller is threatened by grave and imminent danger, which requires immediate assistance. In **radiotelephony** transmission, the distress signal consists of the word **MAYDAY** (pronounced as the French expression '*m'aider*') spoken three times followed by the words **THIS IS** and the identification of the station seeking assistance. A distress message should be followed by the distress call.

It contains name of the ship, aircraft or vehicle, position, type of distress and the type of assistance asked for including any other relevant information to facilitate rescue operation.

In **radiotelegraphy**, the distress signal consists of the letters **SOS** sent in Morse Code characters **... \_ \_ . . . (SOS)**. All these characters should be transmitted three times as a single signal where *dashes* are to be emphasized to enable distinguish them clearly from the *dots*. A typical distress message may look like: **SOS**

**SOS SOS CQ CQ CQ DE** followed by the call-sign. When the distress traffic is over, the distress station should end its transmission with the Q-Code. It looks like: **SOS CQ CQ CQ DE 'call-sign' QUM SK**.

### **Q. What action should you take if you receive a distress call?**

The distress call has **absolute priority** over all other transmissions. Hence it would be your utmost duty to

- listen to the distress call and stop your transmissions if you were previously occupying that frequency;
- acknowledge receipt of the distress message if the station in distress can copy your signal.
- At the same time, it would be your duty to ensure that your transmission does not interfere with transmissions of other stations, which may be better situated to render assistance.
- Even if you cannot render assistance, you should direct the attention of other stations in the nearby frequencies, because they might be in a position to render immediate assistance.
- You shall also try to inform the appropriate authorities, who might be able to conduct a rescue operation.

### **Q. What is an 'Urgency Signal'?**

Urgency signal is a wireless message which indicates that the calling station has a very urgent message to transmit concerning the safety of a ship/vehicle or that of a person but the message cannot be ranked as distress message. **Obviously, the urgency signal should be given priority over all other transmissions except distress call.**

In radio telephony, the word **PAN** is repeated three times pronouncing it as the French word '*panne*'. Other procedures to be followed in this type of traffic is same as that in distress traffic.

In radio telegraphy, the urgency signal consists of the group **XXX** ( \_ . . \_ \_ . . \_ \_ . . \_ ) sent slowly three times. Letters of each group should be clearly separated from each other. The urgency signal transmitted by a ship can be addressed to a specific station. However, a coast station can transmit its urgency signal to all the ship stations after the approval of a responsible authority.

### **Q. What is a 'Safety Signal'?**

A safety signal is a message concerned with the safety of ships/vehicles indicating a meteorological warning (e.g. storm), danger to navigation warning or other navigational-aid message. Safety Signal is an important message because a delay in its transmission or reception can bring a disaster.

In radio telephony, safety signal consists of the word '**SECURITY**' pronounced as '*say-cure-ity*'.

In radio telegraphy, it consists of the three repetitions of the group **TTT** ( \_ \_ \_ ) sent slowly followed by the station call-sign. Letters of each successive group should be clearly separated from each other.

### **Q.What do you understand by the word 'phonetics' in amateur radio communication?**

If we listen to a two-way amateur wireless conversation for the first time in our life, we would come across certain words, which perhaps we never heard before! There is every possibility that we mistake these words for some kind of secret codes! These words in fact are internationally used for plain language (**conversation in secret code language is not allowed in amateur radio communication**) conversation and are known as phonetics.

A ham radio operator has to face different types of hurdles during an ongoing communication. There may be static noise, signal fading, interference from other station operating at close frequencies, local noises in the radio room, unusual voice accents of the other operator, improper pronunciation of words etc.. During these and many other difficulties, it has been found that use of phonetics improves the intelligibility in communication. For example, the letter '**D**' is represented by the word '**Delta**' in phonetics while the letter '**B**' is represented by '**Bravo**'. To distinguish '**M**' from '**N**', hams use the words '**Mike**' and '**November**' respectively.

Phonetic alphabet is useful when calling distant station or when the band is crowded, or when for any reason the station called is expected to have difficulty in copying voice signals. For example, the word 'Solstice' can be spelt using phonetic alphabet as **Sierra Oscar Lima Sierra Tango India Charlie Echo**. A person conversant in listening to such phonetics gets habituated in spontaneously writing down the exact word out of these phonetics! He feels more comfortable at writing down a message spelt out in phonetics rather than simple mentioning of each letters.

Phonetics are to avoid confusion and not to create confusion! Many letters of the alphabet sound similar unless very clearly heard. B may be heard as G or D or V. The word 'bed' may be heard as 'bet' or 'pet'. So, if we spell it out with phonetics like **Bravo Echo Delta**, the confusion easily gets eliminated! Good operating procedures include using the standard phonetic alphabet to help communicate more clearly. The recommended phonetics are those prescribed by the International Radio Regulations. The numbers are spelled differently to suggest a particular pronunciation. Also, nine was changed to "niner" to avoid confusion with the German word "*nein*" for "no". When first making contact with another Ham, it is a good idea to say call signs in phonetics to give the other side a better chance of understanding them correctly.

### **Phonetics used by amateur radio operators**

<u>Letter</u>	<u>Word used as phonetics</u>	<u>Spoken as</u>
A	Alpha	AL FAH
B	Bravo	BRAH VOH
C	Charlie	CHAR LEE
D	Delta	DELL TAH

E	Echo	ECK OH
F	Foxtrot	FOKS TROT
G	Golf	GOLF
H	Hotel	HOH TELL
I	India	IN DEE AH
J	Juliet	JEW LEE ETT
K	Kilo	KEY LOH
L	Lima	LEE MAH
M	Mike	MIKE
N	November	NO VEM BER
O	Oscar	OSS CAH
P	Papa	PAH PAH
Q	Quebec	KEH BECK
R	Romeo	ROW ME OH
S	Sierra	SEE AIR RAH
T	Tango	TAN GO
U	Uniform	YOU NEE FORM
V	Victor	VIK TAH
W	Whiskey	WISS KEY
X	X-ray	ECKS RAY
Y	Yankee	YANK KEY
Z	Zulu	ZOO LOO

### Phonetics used against figures or marks

<u>Figure or mark</u>	<u>Word used as phonetics</u>	<u>Spoken as</u>
0	NADAZERO	NAH-DAH -ZAY-ROH
1	UNAONE	OO-NAH-WUN
2	BASSOTWO	BESS-SOH-TOO
3	TERRATHREE	TAY-RAH-TREE
4	KARTEFOUR	KAY-TAY-FOWER
5	PANTAFIVE	PAN-TAH-FIVE
6	SOXISIX	SOK-SEE-SIX
7	SETTENSEVEN	SAY-TAY-SEVEN
8	OKTOEIGHT	OK-TOH-AIT
9	NOVENINE	N0-VAY-NINER
Decimal point	DECIMAL	DAY-SEE-MAL
Full stop	STOP	STOP

### Q. What are Q-codes?

A 'Q-code' consists of three letters starting with the letter 'Q'. Q-codes are devised to facilitate faster communication in Morse code. Instead of sending a long sentence, the amateur radio operator can just send a combination of three letters to represent a long sentence. If the amateur radio operator asks something to his fellow operator, then the Q-code is followed by a question mark. If the Q-code is used to represent a statement (not a question), then it is not ended with a question mark. For example, if you want to ask your friend on the air whether he is busy (Are you busy?), the Q-code will be 'QRL?'. If you want to say that you are busy, send 'QRL'. There are nearly 100 Q-Codes used by the marine radio operators. We have mentioned below the Q-codes

required to be learnt by an amateur radio operator. Q-codes are very often used during the voice communication also.

QRA? What is the name of your station?

QRA The name of my station is .....

QRG? Will you tell me my exact frequency (or, that of .....)?

QRG Your exact frequency (or, that of .....) is ....kHz (or MHz).

QRH? Does my frequency vary?

QRH Your frequency varies.

QRI? How is the tone of my transmission?

QRI The tone of your transmission is: (1) Good. (2) Variable. (3) Bad.

QRK? What is the readability of my signals (or, those of.....)?

QRK Readability is: (1) Unreadable. (2) Readable now and then. (3) Readable with difficulty. (4) Readable. (5) Perfectly readable.

QRL? Are you busy?

QRL I am busy (or, busy with .....). Please do not interfere.

QRM? Are you being interfered with?

QRM I am being interfered with.

QRN? Are you troubled by static noise?

QRN I am troubled by static noise.

QRQ? Shall I send faster?

QRQ Send faster (... wpm)

QRS? Shall I send more slowly?

QRS Send more slowly.

QRT? Shall I stop sending?

QRT Stop sending

QRU? Have you anything for me?

QRU I have nothing for you.

QRV? Are you ready?

QRV I am ready.

QRW? Shall I inform ..... that you are calling him on .....kHz?

QRW Please inform ..... That I am calling him on .... kHz.

QRX? When will you call me again?

QRX I will call you again at .....hours.

QRZ? Who is calling me?

QRZ You are being called by.

QSA? What is the strength of my signals (or those of .....)?

QSA Your signals are (1) Scarcely perceptible. (2) Weak. (3) Fairly good. (4) Good. (5) Very good.

QSB? Are my signals fading?

QSB Your signals are fading.

QSL? Can you acknowledge receipt?

QSL I am acknowledging receipt.

QSO? Can you communicate with ..... direct or by relay?

QSO I can communicate with .... Direct or by relay through .....

QSU? Shall I send or reply on this frequency (or, on ....kHz)(with emissions of class...)?

QSU Send or reply on this frequency (or, on .... KHz) (with emissions of class ....).

QSV? Shall I send a series of 'V's on this frequency (or, .... KHz).

QSV Send a series of 'V's on this frequency (or, .....kHz).

QSW? Will you send on this frequency (or, ... kHz)(with emissions of class ...)?

QSW I am going to send on this frequency (or, .....kHz) (with emissions of class ...).

QSX? Will you listen to ....(call-sign) on .....kHz?

QSX I am listening to ... (call-sign) on .....kHz.

QSY? Shall I change my transmission to another frequency?

QSY Change your transmission to another frequency.

QSZ? Shall I send each word or group more than once?

QSZ Send each word or group twice (or, ..... times).

QTC? How many telegrams have you to send?

QTC I have ..... telegrams for you (or, for .....).

QTH? What is your position in latitude and longitude (or, according to any other indication)

QTH My position is ...latitude .....longitude (or, according to any other indication).

QTR? What is the correct time?

QTR The correct time is .....hours.

QUM? Is the distress traffic ended?

QUM The distress traffic is ended.

### **Q. What are the designation of emissions allotted to amateur radio service?**

The most common designation of emissions, which are allotted to hams, are:

- A1A** : Continuous Wave (CW) Double side -band telegraphy for aural reception which contains quantized digital information without the use of modulating sub-carrier. (allotted to Grade II , Grade I and Advanced Grade Licence holders)
- A2A**: Continuous Wave (CW) Double side-band telegraphy for aural reception, which contains quantized digital information with the use of modulating subcarrier.
- A3E**: Double side-band single channel analog transmission containing telephony (including sound broadcasting). Commonly known as AM (Amplitude Modulation).
- H3E**: Single side band, full carrier single channel analog transmission containing telephony (including sound broadcasting).
- J3E**: Single side band, suppressed carrier single channel analog transmission containing telephony (including sound broadcasting).
- R3E**: Single side band, reduced or variable-level carrier single channel analog transmission containing telephony (including sound broadcasting).
- F3E**: Frequency modulated single channel analog transmission containing telephony (including sound broadcasting).
- F1B**: Frequency modulated single channel telegraphy transmission containing quantized digital information for automatic reception.
- F2A**: Frequency modulated single channel telegraphy transmission containing quantized digital information for aural reception.

**F2B:** Frequency modulated single channel telegraphy transmission containing quantized digital information with modulating sub-carrier for automatic reception.

**F3C:** Frequency modulated single channel analog facsimile transmission.

**A3C:** Amplitude modulated double side-band single channel analog facsimile transmission.

**A3F:** Amplitude modulated double side-band single channel analog video transmission.

Each letter/digit of the designation of emission represent independent meaning as assigned to them.

**Q. What are the frequencies allotted to a Grade-I licence holder in India?  
How much power is allowed to a Grade-I licence holder?**

The radio frequencies allotted to a Grade-I licence holder in India are:

<u>Short wave/High Frequencies (HF) :</u>	<u>VHF/UHF/SHF:</u>
1820-1860 kHz	144-146 MHz
3500-3700 kHz	434-438 MHz
3890-3900 kHz	1260-1300 MHz
7000-7200 kHz	3300-3400 MHz
14000-14350 kHz	5725-5840 MHz
18068-18168 kHz	
21000-21450 kHz	
24890-24990 kHz	
28000-29700 kHz	

In India, a Grade-I licence holder is allowed to use 150 watts in the HF bands and 25 watts in the VHF/UHF bands.

## F. Radio Telephony Operating Procedure

Once you get your ham radio licence and the call-sign, it is time for you to start transmission. Radio waves are now-a-days a precious commodity and so the ham should not misuse them for his/her own ends. It is the duty of the ham to know the correct operating procedure. If a newly licensed ham radio operator is ignorant about the correct operating procedures, he may create nuisance in the band. A ham should also be aware about the International Operating Code devised by Paul M. Segal.

### Code for a ham radio operator

1. The ham is considerate. He/she never knowingly uses the air (radio waves) in such a way as to lessen the pleasure of others.
2. The ham is loyal. He/she offers his/her loyalty, encouragement and support to his/her fellow hams, his/her local clubs.
3. The ham is progressive. He/she keeps his/her station (radio equipment) abreast of science. It is well-built and efficient. His/her operating practice is above reproach.

4. The ham is friendly. Slow and patient sending when requested, friendly advice and counsel to the beginner, kindly assistance, co-operation and consideration for the interests of other; these are the mark of the ham spirit.
5. The ham is balanced. Radio is his/her hobby. He/she never allows it to interfere with any of his/her duties he/she owes to his/her home, his/her job, his/her school or community-and lastly his/her knowledge and his/her radio station are always ready for the service of his/her country and his/her community.

### Calling another station

A call may be given to another station either in voice or using the Morse code. But before giving a call, it is the duty of the ham to check whether the frequency he/she is going to use is already in use by other ham/s or not. Even though a particular frequency seems to be idle, it may not be so. Because, there may still be a ham sending his message whose signals are in skip with us (see questions & answers related to radio wave propagation) and another ham at a different location is listening to him. Giving a transmission in the same frequency in such a situation may interfere with the ongoing communication. So, prior to transmission, it should be ascertained by sending the message- “Is the frequency in use?”. This should be repeated two more times and if no reply is received, we can occupy the frequency. After occupying a frequency, we can give a ‘**General Call**’ or a ‘**Directional Call**’. A ‘General Call’ is a call given to all the stations. This means that you will reply to anybody from any part of the world. The message sounds like –“**CQ CQ CQ this is Victor Uniform**

**Two.... (your call-sign suffix in phonetics) calling CQ on 20 metre and standing by**”. The ‘CQ’ message may be repeated for three time before giving the ‘**standing by**’ message. As you ‘stand by’, listen carefully for any possible reply. If no reply is received, you can continue giving your CQ call. There is also a ‘**Directional Call**’ which is **directed to a particular country or a particular station**. A call directed to a particular country is like-“**CQ Japan CQ Japan CQ Japan this is Victor Uniform Two .....**”. This means that you will reply to stations from Japan only. A call may be directed to a particular station also. In this case, the country name is to be replaced with the intended station ‘call-sign’. **A person with the true ham spirit does not adhere strictly to his directional call, and as such should not deny reply to a ham from another country replying to his directional call (in the above example) until and unless he is in real emergency. Also there is nothing official about a ham radio operation.** Ham radio operators also form net. When a net is going on, you can also join the net once somebody in the net ‘pulls you’ into the net. To indicate that you want to join the net, a short ‘**BREAK**’ call may be given.

After establishing contact and offering the initial greetings, **a signal report** should be given to the other station. Your name (**Handle**) and location (**QTH**) should then be spelled out clearly in internationally accepted phonetics. If the other ham finds difficulty in copying your voice signal due to poor propagation condition or due to the difference in pronunciation, you should not lose patience and the message should be repeated if requested. You can also give the weather report (**WX report**) by mentioning the temperature in degrees Celsius. After this, discussion regarding the antenna system and equipment (called-“**Working condition**”) begins. Before closing the conversation with a particular station, **73** message (meaning ‘**Best of Regards**’) should be conveyed to the ham and his family and indication should be given whether you are closing down (**going QRT**) your station, you are changing your frequency

(**QSYing**) or you are still occupying the frequency. This will help other stations to follow you in case they want to make a contact with you. If the conversation takes long time, both the stations should repeat their call-sign at least at ten minutes interval.

## Signal Report in Radio Telephony

When on-the-air contact between amateur radio stations is established, both the stations exchange signal reports. This gives the idea about how strongly the ham radio stations are receiving each other. For telephony (voice), Readability and Signal strength scale is devised.

Readability Scale		Signal Strength Scale	
R1	Hardly perceptible; unreadable	S1	Unintelligible; barely perceptible
R2	Weak; readable now and then	S2	Weak signals; barely readable
R3	Fairly good; readable but with difficulty	S3	Weak signals; but can be copied
R4	Good; readable	S4	Fair signals
R5	Very good; perfectly readable	S5	Fairly good signals
		S6	Good signals
		S7	Moderately strong signals
		S8	Strong signals
		S9	Extremely strong signals

A 59 (5 and 9) report is the best report in radiotelephony. You should be honest in giving a signal report. Don't give a good report just to please your friend! There may be some problem in the antenna system of your friend's station due to which you are receiving him poorly. Or there may be some problem in the audio quality of your friend's transmission. Under such a situation, giving a false report will just misguide your friend and your friend may not be able to detect/rectify the fault in his/her system.

## G. Radio Telegraphy Operating Procedure

In radio telegraphy contact using Morse Code, the RST (Readability, Signal Strength and Quality of Tone) system of reporting is followed. Throughout the world, Morse code is still used very affectionately by thousands of ham radio operators. They make conversation as fluently as they do in voice using Morse code. In fact Morse Code has many advantages over voice communication in certain situations, as well as for the sheer joy involved in this art of communication, which we have discussed in the chapter on Morse code learning. In Morse code also, either general CQ call or directional call can be given. The calling format is as follows:

### General call:

**CQ CQ CQ DE VU2XYZ VU2XYZ VU2XYZ AR PSE**

### K Specific/Directional Call:

**CQ/VU2ABC CQ/VU2ABC CQ/VU2ABC DE VU2XYZ VU2XYZ VU2XYZ AR KN**

In Morse code, long words are usually avoided and hence only the abbreviated form of the words are sent. There are certain Internationally accepted Morse Code abbreviations which you should remember and use during communication. '**AR**' is synonymous to saying '**over**' in voice (A voice message should be ended with the word 'over to .....'). '**K**' is the invitation to transmit which is synonymous to saying '**go ahead**' in voice communication. A message ended with **KN** indicates that the message was directed to a particular station only. During an ongoing communication also, the message should be ended with '**KN**' which provides the information to the other stations that communication was already in progress between two stations. Each sentence of the message should be separated by '**BT**'. Given below is a typical Morse code message.

**VU2XYZ DE VU2ABC BT TNX FER CALL BT UR RST RST IS 579 BT MY NAME IS .....ES QTH IS ..... BT OK? AR VU2XYZ DE VU2ABC KN**

When you finally close your conversation with a particular station, indication should be given, i.e. the message should be ended with '**VA**' (meaning '**over and out with .....**'). A typical closing message may look like-..... **VU2ABC DE VU2XYZ VA**. This means that VU2XYZ is now free to communicate with other stations.

### The RST System

<b>Readability</b>	<b>Signal Strength</b>	<b>Tone</b>
R1-Unreadable	S1-Faint, signals barely	T1-Extremely rough hissing note
R2-Barely readable, occasional words distinguishable	S2-Very weak signals	T2-Very rough AC note, no trace of musicality
R3-Readable with considerable difficulty	S3-Weak signals	T3-Rough. Low-pitched AC note, slightly musical
<b>Readability</b>	<b>Signal Strength</b>	<b>Tone</b>
R4-Readable with practically no difficulty	S4-Fair signals	T4-Rather rough AC note, moderately musical
R5-Perfectly readable	S5-Fairly good signals	T5-Musically modulated note
	S6-Good signals	T6-Modulated note, slight trace of whistle
	S7-Moderately strong signals	T7-Near DC note, smooth ripple
	S8-Strong signals	T8-Good DC note, just trace of ripple
	S9-Extremely strong signals	T9-Purest DC note

## Abbreviations used in Radio Telegraphy (Morse Code)

<b>AA</b>	Artificial antenna or all after
<b>AB</b>	All before
<b>ABT</b>	About
<b>AGN</b>	Again
<b>ANI</b>	Any
<b>ANT</b>	Antenna
<b>AR</b>	Over
<b>AS</b>	Wait
<b>BK</b>	Break
<b>BC</b>	Broadcast
<b>BCL</b>	Broadcast band Listener
<b>BCNU</b>	Be seeing you
<b>BT</b>	Separation
<b>C</b>	Yes
<b>CFM</b>	Confirm
<b>CL</b>	Closed
<b>CO</b>	Crystal Oscillator
<b>CQ</b>	General Call
<b>CONDX</b>	Conditions
<b>CU</b>	See you
<b>CUL</b>	See you later
<b>CK</b>	Check
<b>CANS</b>	Headphone
<b>DE</b>	This is
<b>DF</b>	Direction Finding
<b>DX</b>	Long distance
<b>ECO</b>	Electron Coupled Oscillator
<b>ERE/HR</b>	Here
<b>ES</b>	And
<b>FER</b>	For
<b>FB</b>	Fine Business
<b>FR</b>	For
<b>FONE</b>	Telephony (voice)
<b>CKT</b>	Circuit
<b>GA</b>	Go ahead/Good afternoon
<b>CLG</b>	Calling
<b>GE</b>	Good evening
<b>GM</b>	Good morning
<b>CPSE</b>	Counterpoise
<b>GLD</b>	Glad
<b>GND</b>	Ground
<b>GUD</b>	Good
<b>HI</b>	Laughter
<b>HPE</b>	Hope
<b>HR</b>	Here
<b>HRD</b>	Heard

<b>HV</b>	Have
<b>K</b>	Go ahead (general request)
<b>KN</b>	Go ahead (directional request)
<b>KCS</b>	Kilocycles
<b>LID</b>	Bad operator
<b>MNI</b>	Many
<b>MO</b>	Master Oscillator
<b>MCS</b>	Megacycles
<b>ND</b>	Nothing doing
<b>NW</b>	Now
<b>NIL</b>	Nothing
<b>OB</b>	Old Boy (Young male operator: a novice)
<b>OM</b>	Old Man (Male operator: not a novice)
<b>OK</b>	All correct
<b>OP</b>	Operator
<b>PSE</b>	Please
<b>PX</b>	Press
<b>QRP</b>	Very low power
<b>QSL</b>	Received
<b>R</b>	Roger (Copied OK)
<b>RCVD</b>	Received
<b>RCVR</b>	Receiver
<b>RPRTR</b>	Report
<b>RPT</b>	Repeat the message
<b>RX</b>	Receiver
<b>SA</b>	Say
<b>SED</b>	Said
<b>SIGS</b>	Signals
<b>SWL</b>	Short Wave Listener
<b>TKS</b>	Thanks
<b>TNX</b>	Thanks
<b>TX</b>	Transmitter
<b>TU</b>	Thank you
<b>U</b>	You
<b>UR</b>	Your/ You are
<b>VA</b>	End of work
<b>VY</b>	Very
<b>WA</b>	Word after
<b>WB</b>	Word before
<b>WX</b>	Weather
<b>WID</b>	With
<b>WKD</b>	Worked
<b>WL</b>	Will
<b>WUD</b>	Would
<b>XMTR</b>	Transmitter
<b>XTAL</b>	Crystal
<b>XYL</b>	Wife
<b>YF</b>	Wife
<b>YL</b>	Young Lady (unmarried)

73 Best of regards  
88 Love & Kisses

## Ham terminology

BAREFOOT- A transmitter running without an external linear RF amplifier.

HARMONIC- Daughter or Son of the ham radio operator (just as the harmonic frequency generated out of the fundamental frequency!)

HANDLE- Name of the ham radio operator

TICKET-The Amateur Wireless Telegraph Licence

RIG- Wireless apparatus

HOME BREWED EQUIPMENT- A home made

apparatus SHACK- Radio room

## Part-III

# Radio Theory and Practice

## A. Elementary Theory of Electricity & Magnetism

### What is electronics?

Electronics is the field of manipulating electrical currents and voltages using passive and active components that are connected together to create circuits. Electronic circuits range from a simple load resistor that converts a current to a voltage, to computer central processing units (CPUs) that can contain millions of transistors. Electronic devices operate by the movement of electrons through conductors, e.g. wires, and electronic components.

### What are passive components?

Resistors, inductors, transformers and capacitors are called *passive devices*. They don't alter their resistance, impedance or reactance when alternating currents (ac) are applied to them.

### What are active components?

Vacuum tubes, diodes, transistors etc. are called active devices. They change their resistance or impedance when varying voltages are applied to them and as a result can amplify, rectify, modify or distort ac waveforms. Passive devices normally don't distort waveforms.

## Matter and electricity

Before going to discuss the different theories related to electricity and magnetism, we would like to give a brief idea about matter. All matter consist of molecules. A molecule can be defined as the smallest particle, which shows all the characteristics of a particular matter. For example, molecule of water is obtained by dividing a drop of

water again and again until it cannot be divided and still be water. Further division of this water molecule will yield three particles which are not water. Molecule of water contains two atoms of hydrogen (H) and one atom of oxygen (O) . A molecule may contain one atom or more than one atom. An atom can be further divided into three particles known as protons, electrons and neutrons. Protons and electrons are the particles possessing electrical properties whereas neutron is electrically neutral.

**Electrons** are the **negatively charged** particles, which revolve around the positively charged **protons** (which constitute the nucleus of an atom along with neutrons). **Proton is about 1800 times heavier than electron.** There is always attraction between unlike charges. Because electron is much lighter than proton, hence it is pulled towards the proton. If the force of attraction is enough, then the electron comes too closer to the proton and both the particles together form a neutral particle to be known as neutron. **Atoms, of all elements, except hydrogen contain one or more neutron in their nucleus.**

The electrical charge of an electron can be explained with the help of an imagination that there exist lines of forces, which are outward pointing. Though the size & weight of electron and proton varies significantly, the negative field of an electron is just as strong negatively as the positive field of a proton is positive. Small though it is physically, the field near the electron is quite strong. The strength of the field varies inversely with the distance squared.

Though electrons and protons have different kind of charge in them, both have charges of equal magnitude. An electron (negatively charged) repels another electron, while a proton (positively charged) repels another proton. So the basic physical law states:

***”Like charges repel; unlike charges attract”.***

### **What is charge?**

When the electrons are stored up and not moving, there is no current, but there is charge. The amount of charge is measured in terms of ‘coulomb’. One coulomb is equivalent to  $6.28 \times 10^{18}$  electrons.

### **What is current?**

Atoms of a metal form a crystal lattice, and in the spaces between the lattice points free electrons move chaotically, wandering aimlessly here and there. But it is enough to connect a metal plate to the two poles of a voltage source for the electrons immediately to acquire an aim. They will move towards the positive pole of the battery, and an electric current will begin to flow in the metal. An electric current can also flow in a gas. A voltage applied across a gas-filled tube causes ionization of the gas: free electrons stream towards the plate with the positive potential, colliding with the atoms in their way and detaching electrons from their orbits. The positive ions move toward the opposite end of the tube. **Current is the rate of flow of charge, i.e., the number of coulombs flowing past a point per second. Its unit is ampere (A) or amp. One amp is equal to one coulomb per second.**

## What is voltage?

Voltage is also called potential (Potential is defined as the work required from some energy source in moving a unit positive charge between two points in an electric field), potential difference, potential drop, or electromotive force-EMF. It is the electronic potential energy between two points, and is the driving force that causes charge to flow. Its unit is volt (V). One volt is defined as the potential difference that requires one joule of energy to move one coulomb of charge. Voltage is always measured relative to some other point in a circuit, e.g. the potential across a resistor. Voltage measurement made at a single point in a circuit are made relative to the earth (ground), which is assigned an “absolute” voltage of zero.

## Types of Electricity

### Direct Current (DC)

The direct current flows in one direction in a circuit. DC voltage has a fixed polarity (e.g. a battery or an electrical cell) and the magnitude of the voltage remains constant. In an electrical circuit, the flow of electric current is indicated by an arrow mark originating from the positive terminal of the battery towards the negative terminal of the battery. This is the conventional method of showing the direction of current flow. But the real direction of electron flow is from the negative terminal of the battery to the positive terminal.

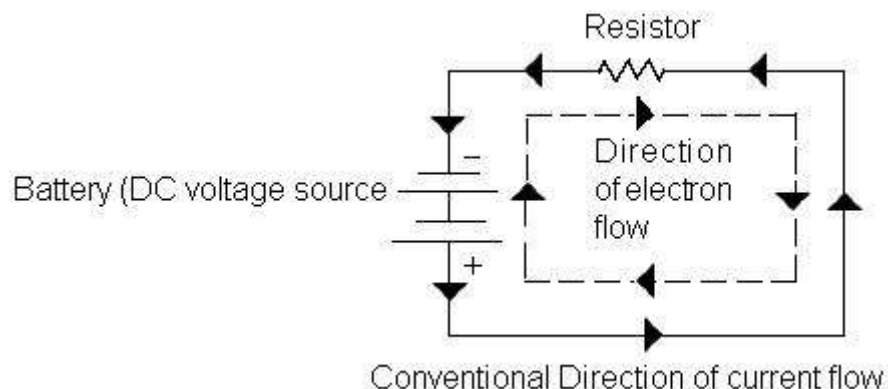

### Alternating Current (AC)

Alternating current flows first in one direction for one-half cycle and then in the opposite direction during the other half cycle. The same definitions apply to alternating voltage. AC voltage switches polarity back and forth. AC voltage/current has a wave-form which represent the frequency of the source. The wave-form of the household ac is known as the ‘sine’ wave. The magnitude of the A.C. voltage changes with time. AC is obtained from A.C. generators.

### Advantage of AC

Heat is developed in all type of electrical circuits due to the flow of electric current. The magnitude of the D.C. being constant produces more heat in a circuit compared to the heat produced by an A.C. In long distance transmission lines, large amount of

power will be dissipated in the form of heat if D.C. is used which can be reduced by the use of A.C.

A.C. Voltage can be measured in four different ways.

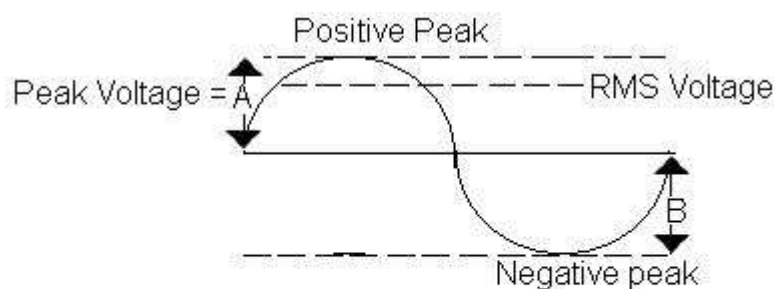

A Sine wave cycle. The upper half denotes the positive cycle and the lower half denotes the negative cycle

### Peak Voltage

The value or amplitude of an A.C. voltage never remains constant. With an initial voltage of zero, the amplitude rises to a peak value, after which it again falls back to zero. After reaching zero, the direction of the current changes and the voltage rises to its negative peak. Peak voltage measurement is necessary to ensure or know that the amplitude of the A.C. voltage does not exceed a limit.

### Instantaneous Voltage

It is also called the **average voltage**. The voltages, if measured, at different points of the half cycle of the sine wave will be the instantaneous voltages. But practically it is not possible. So one way to denote instantaneous voltage is to take the average voltage. In a sine wave A.C. voltage, the average voltage can be found out by multiplying the 'peak voltage' by a constant (value of the constant can be worked out to be equal to 0.367).

### Root-Mean-Square Voltage

Measuring an A.C. voltage involves the use of a meter which measures AC Voltage in terms of how much DC voltage it would take to have the same effect in a circuit. Since during most of the cycle the AC has a value less than the value at its peak, or for that matter, than of a constant DC voltage, it will not be able to produce as much heat (in a heating element) as produced by the same amount of DC voltage. Power being proportional to either  $E^2$  or  $I^2$  ( $P=E^2/R=I^2R$ ), if all the instantaneous values of a half cycle of sine-wave current (or voltage) are squared and then the average, or mean, of all the squared values is found, the square root of this mean value will be 0.707 of the peak value. This root-mean-square, or rms, value represents how effective a sinusoidal AC will be in comparison with its peak value.

The RMS value is the value of voltage of an AC source, the power consumed by whom is the same as by a d.c. voltage. That is, it is the effective value ( $V_{eff}$ ) of a

sine-wave voltage found from the formula:

$$V_{\text{eff}} = V_{\text{max}} \times 0.707$$

### **Effective Voltage**

In a domestic AC supply, 230 volts is actually the effective voltage ( $V_{\text{eff}}$ ). The actual voltage or the peak voltage ( $V_{\text{max}}$ ) of the supply is :  $V_{\text{max}} = V_{\text{eff}} / 0.707 = 325$  volts. Or, to determine a peak value of AC that will be as effective as a given DC, it is necessary to multiply the effective value given by the reciprocal of 0.707 ( $1/0.707$ ), which is 1.414.

## **Magnetism**

### **What is a magnet?**

A piece of iron, nickel, cobalt, steel, alloy (e.g. alloy made from non-magnetic copper, manganese and aluminum) etc. usually in the form of a bar having properties of attracting or repelling iron and other materials which contain iron is called a magnet. But what gives it its force is not completely known. One of the theories to describe magnetism is the-“Theory of Domains”. It says that materials that can be made into magnets have many tiny crystal like structures called domains. Each domain is made up of many atoms. Each domain has a small magnetic force of its own. When the material is not magnetized, the domains are haphazardly arranged-pointing in all directions-so that their tiny forces cancel each other. To make the material into a magnet, the domains need to be lined up so that their individual magnetic forces all help each other pull the same way. When *most* of the domains line up, the magnet becomes strong. When all of the domains line up in one direction, the magnet is saturated. It cannot be made any stronger regardless of how much you try to magnetise it.

In a magnetic bar, there are two poles: North and South. They are marked as ‘North’ and ‘South’ poles because, when the magnetic bar is suspended horizontally, one of the ends will always point towards the Earth’s geographical north and the other pole towards the Earth’s geographical south. This is because of the fact that the Earth itself behaves like a huge magnet. In a magnet, the like poles repel and the unlike poles attract-a reason for the specific alignment of the magnetic bar. The magnetic bar is surrounded by the invisible lines of forces which originate from the ‘North’ pole and terminate in the ‘South’ pole.

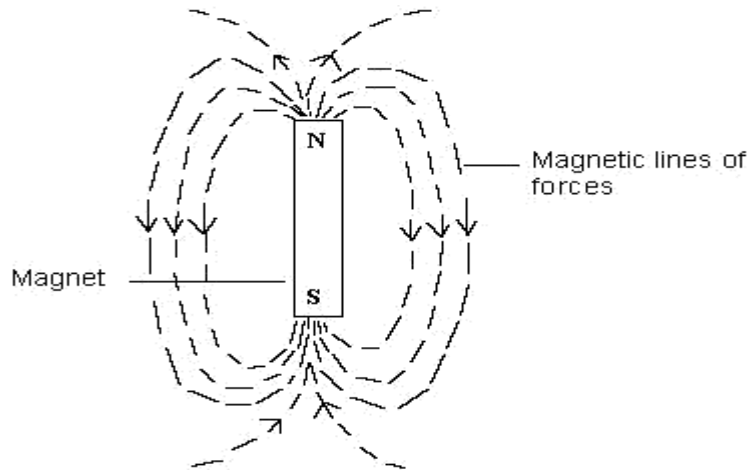

### **Ferro-magnet**

Iron, nickel and cobalt (including the alloy mentioned above) are considered ferromagnetic. Ferro-magnetic materials are difficult to be converted to magnet but once magnetized under the influence of another magnetic field, they cannot be completely demagnetized. Ferromagnetic materials are used to make permanent magnets. **One of the strongest permanent magnetic materials is a combination of iron, aluminum, nickel and cobalt called “Alnico”.**

### **Paramagnet**

Materials which get demagnetized once the external magnetic field is removed are paramagnetic.

### **Use of Permanent magnets in Electronics**

Electricity and electronics cannot be discussed by leaving apart ‘magnetism’ separately. Permanent magnets are used in electronics to make electric meters, headphones, loudspeakers, radar transmitting tubes etc. Temporary magnetic materials are also equally important in electricity and electronics to make devices which may be quickly changed from being magnetic to non-magnetic.

### **Electromagnets**

The flow of an electric current through a wire creates a circular magnetic field around the wire. This magnetic field has the highest intensity near the conducting wire and the intensity gradually decreases as the distance from the wire increases. The direction of these magnetic flux lines can be found by the ‘left hand rule’. If the conducting wire shown below is grasped by the left hand, the curled fingers point to the direction of magnetic flux lines and the thumb shows the direction of current flow.

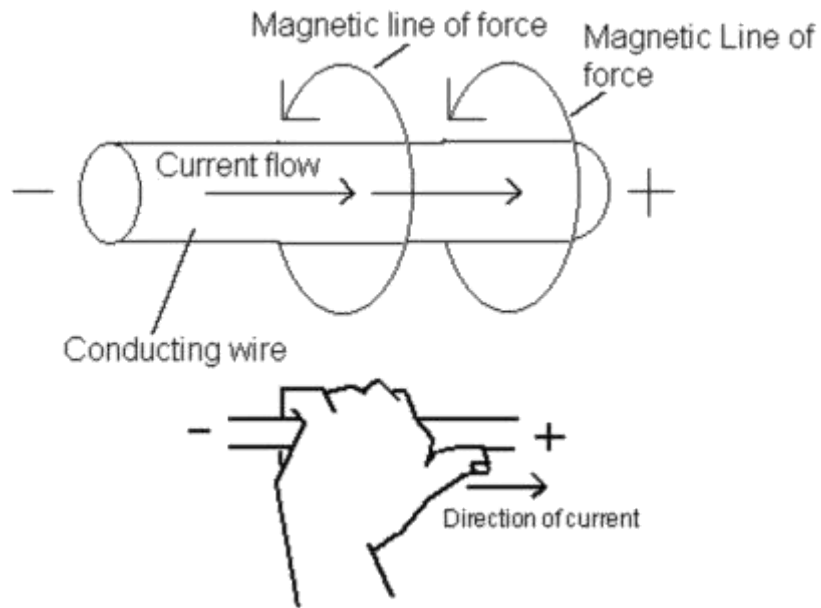

If a straight conducting wire is made into a loop giving it a 'coil' shape, the small magnetic loops around the wire overlap each other resulting in a more stronger magnetic field around the whole coil. The strength of the magnetic field depends on the number of turns in the coil, amount of current in the coil and the permeability of the core material. Air has a permeability of 1. But iron is more permeable than air and is capable of transferring the magnetic flux line more efficiently. Based on this principle, electromagnets can be made. An electromagnet consists of a coil surrounding a soft iron core. The core remains magnetized so long as there is flow of current in the coil. The direction of the magnetic field in a coil can also be found by the 'left hand rule'. If a coil is grasped in left hand, the curled fingers point to the direction of current flow, the thumb shows the direction of magnetic flux and N pole of the coil.

Electromagnets have many applications in electronics. Two of the most important uses of electromagnetism are in **transformers** and **motors**. Electromagnetic relays, electric bells, buzzers are commonly used electromagnets. Electromagnetic relays are used as switching devices in electrical and electronic circuits.

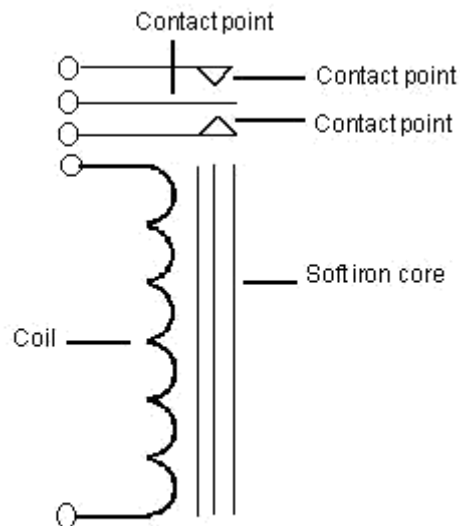

Symbol of an electromagnetic relay

## Transformers

Transformer is a device which consists of two coils arranged in a way so as to generate a magnetic coupling effect (the coupling effect is enhanced by winding the two coils on a common iron core) and thereby transfer electrical energy (AC voltage) from one coil (called the *primary coil*) to the another coil (called the *secondary coil*). A transformer works on the principle of ‘mutual inductance’ ([see page](#)). One of the most useful characteristics of a transformer is its ability to step- up or step-down of AC voltages. The step-up or step-down ratio will be proportional to the turns in each coil, i.e.,

$$V_S = N_S/N_P \times V_P$$

Where,  $V_S$  = Secondary voltage

$N_S$  = Number of turns on secondary

$N_P$  = Number of turns on primary

$V_P$  = Primary voltage

The currents flowing in the primary and secondary follow a similar relationship, but in opposite ratio, i.e.

$$I_S = N_P/N_S \times I_P$$

Where,  $I_S$  = Secondary current

$I_P$  = Primary current

In other words, a step-up in voltage produces a step-down in current and vice versa.

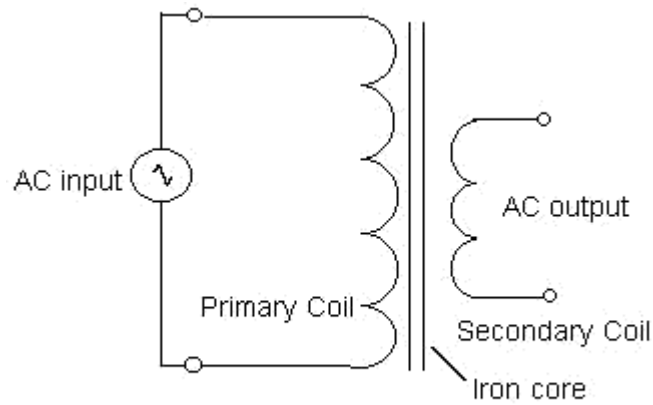

Symbolic form of a step-down transformer

### Transformers as Coupling Device

Transformers are very useful to use in radio or audio frequency circuits as coupling devices. As well as providing coupling, they can act as ‘amplifiers’ to step up an audio or radio frequency voltage (but not as *power* amplifiers); and even more important for impedance (see page ) matching. By choosing the proper turns ratio the impedance of a fixed load can be transformed to any desired higher or lower impedance, within practical limits. This can be a particularly important requirement when coupling transistor radio stages.

For impedance matching, the following relationship applies:

$$\frac{N_p}{N_s} = \sqrt{\frac{Z_p}{Z_s}}$$

Where,

$Z_p$ =Impedance of the transformer looking into the primary terminals

$Z_s$ =Impedance of the load connected to the secondary of the transformer

### Resistors

#### What are resistors?

A resistor is a device designed to have a definite amount of resistance-used in circuit to limit current flow or to provide a voltage. Resistance (R) is the retarding force in a material that impedes the flow of current. The potential (E) needed to achieve a current (I) through a material that behaves linearly, e.g. conductors and resistors, is given by Ohm’s law:

$$E=IR$$

Where,

E=emf (in volts, V)

I=intensity of current (in amperes, A)

R=Resistance (in ohms,  $\Omega$  )

So, if we know any two values, we can find out the other value. The above formula can rearranged as shown below:

$$I = \frac{E}{R} \text{ or Current in amperes} = \text{volts/ohms}$$

From this formula, it is evident that-“**Current varies directly as the voltage and inversely as the resistance**”.

The formula can also be arranged to find out the resistance in a circuit if the voltage and current are known.

$$R = \frac{E}{I} \text{ or Resistance in ohms} = \text{volts/amperes}$$

### Practical Resistors

The resistance of a material depends on four physical factors:

- (1) The **type of material** from which it is made. For example copper and silver are very good conductors of electric current, but iron is six times lesser in its conductivity than them.
- (2) The **length** (greater the length greater is the resistance).
- (3) **Cross-sectional area** (greater the cross-sectional area larger the amount of free electron implying lesser resistance).
- (4) **Temperature** (except for carbon and other semiconductor materials).

So each material has a specific resistance inherent in them. **The specific resistance of a material is the number of ohms in a 1 foot long 0.001 inch diameter round wire of that material at room temperature.** Silver has the least specific resistance, i.e.  $9.75 \Omega$  and nichrome is an alloy, which has specific resistance as high as  $660 \Omega$ .

### Wire-wound resistor

Nichrome or german silver wires are wound on a tubular ceramic form to make wire-wound resistor. Wire-wound resistors are generally available in values from 1 ohms to 300 kilohms. Power ratings of this type of resistors vary from 1 to 50 watts.

### Carbon resistor

Powdered carbon is mixed with a binding material and baked into small, hard tubes with wire attached to each end to make carbon resistors. The percentage of carbon in the mixture determines the resistance value in ohms. Carbon resistors are generally available in values from 10 ohms to 22 megaohms. Power ratings of this type of resistors vary from 1/8 watt to 2 watts.

### Colour codes of resistors

Carbon resistors are colour coded to indicate their values. Each resistor has four colour bands on its body. The first band (the band which is nearest to the end of the resistor) is the first number. The second band is the second number. The third band is the multiplier, i.e. number of zeros following the second number.

Colour	Band 1	Band 2	Band 3
--------	--------	--------	--------

Black	0	0	
Brown	1	1	0
Red	2	2	00
Orange	3	3	000
Yellow	4	4	0000
Green	5	5	00000
Blue	6	6	000000
Violet	7	7	0000000
Gray	8	8	00000000
White	9	9	000000000

Resistors having values lower than  $10 \Omega$  have three colour bands. The third band is either golden or silver in colour. A golden band indicates that the first two numbers are to be multiplied by 0.1. A silver band indicates multiplication by 0.01. The tolerance of three band resistors is 20%. If the golden or silver band is the fourth band respectively, then they indicate a tolerance of 5% and 10% respectively.

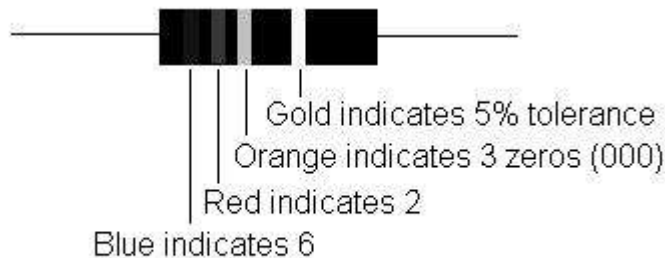

The value of this resistor is  $62000 \Omega$  or  $62 \text{ k}\Omega$

### Questions:

1. A circuit has a resistance of 100 ohms and voltage applied across the circuit is 20 volts. What is the amount of current flowing through it?

We have,  $I = \frac{E}{R}$  or  $I = 20/100 = 0.2 \text{ A}$  (ampere) or 200 mA (milliampere)

2. Find out the voltage required to produce 3 A of current through a  $50 \Omega$  (ohms) resistor.

We have,  $IR = E$  or  $3 \times 50 = 150 \text{ V}$  (volts)

### Power and Energy

As mentioned above, heat is developed in the load resistor as a result of current flowing through it. In absence of the load, a battery despite having the electromotive force (EMF), cannot produce movement of electrons and no electrical work is accomplished. When there is a load across the battery, movement of electrons take place. The product of the EMF (in volts) and movement of electrons (in amperes) gives us the amount of electrical work accomplished whose unit is watt (W).

$$P = EI$$

Where P=power (in watts, W)

$E = \text{emf (in volts, V)}$

$I = \text{current (in amperes, A)}$

So, 1 V causing 1 A to flow through a 1  $\Omega$  resistor produces 1 W of power.

The above formula can also be expressed as

$$P = EI = (IR)I = I^2R \text{ (because the ohm's law states: } E = IR)$$

Or

$$P = EI = E\left(\frac{E}{R}\right) = \frac{E^2}{R} \text{ (because the ohm's law states: } I = \frac{E}{R})$$

### Questions:

1. Find out the heat dissipated by a 50  $\Omega$  resistor when 0.25 A of current flow pass through it.

$$\text{We have, } P = I^2R \text{ or } P = 0.25^2 \times 50 = 0.0625 \times 50 = 3.125 \text{ W}$$

2. Find out the power dissipated by a 10,000  $\Omega$  resistor connected across a voltage source of 250 V.

$$\text{We have } P = \frac{E^2}{R} = \frac{250^2}{10,000} = 6.25 \text{ W}$$

3. Find out the maximum voltage that may be connected across a 20 W, 2000  $\Omega$  resistor.

$$\text{We have, } P = \frac{E^2}{R}$$

$$\text{Or, } E^2 = PR$$

Or,

$$E = \sqrt{PR}$$

Or,

$$E = \sqrt{20 \times 2000}$$

$$E = 200 \text{ V}$$

4. Find out the maximum current that can flow through a 100  $\Omega$  1 W resistor.

We have,

$$I = \sqrt{\frac{P}{R}}$$

Or,

$$I = \sqrt{\frac{1}{100}} = 0.1 \text{ A or } 100 \text{ mA}$$

### What are conductors?

Materials which allow the flow of electric current through them are called conductors. Metals are known to be good conductors, with copper and silver among the best. The conductivity of a particular material depends on the number of free electrons present in it. A conductor may be a very good conductor, a fairly good conductor or a poor conductor. So, a greater conductivity or conductance implies lesser resistance and a lesser conductivity implies greater resistance. So, conductance (conductance is expressed in **siemens**, S) and resistance (R) are the same thing but from opposite viewpoints. They are said to be reciprocal of each other, i.e.

$$R = 1/S \text{ or } S = 1/R$$

So the Ohm's law can be expressed in terms of conductance by using  $1/S$  in place of R in the three formulas:

$$E = IR = I(1/S) \text{ or } E = I/S$$

$$I = \frac{E}{R} = \frac{E}{1/S} = E \left( \frac{S}{1} \right) \text{ or } I = ES$$

$$R = \frac{E}{I} \text{ or } \frac{1}{S} = \frac{E}{I} \text{ or } SE = I \text{ or } S = \frac{I}{E}$$

### Resistance in series and parallel

The circuit shown here is a simple circuit with one load or resistor across a voltage source (e.g. a battery).

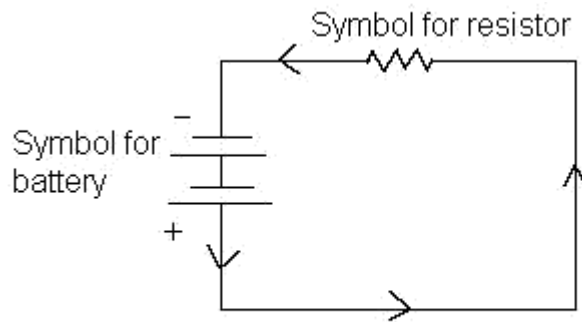

A simple circuit with one resistor and a battery

The circuit shown below is a **series circuit** where three resistors are connected one after another. It is evident from the diagram that there is only path through which current flows.

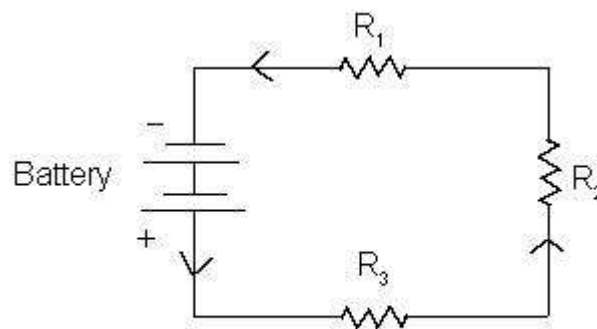

A series circuit with three resistors in series

The circuit shown below is a parallel circuit where each resistor has its independent path for the flow of current from the same source of voltage.

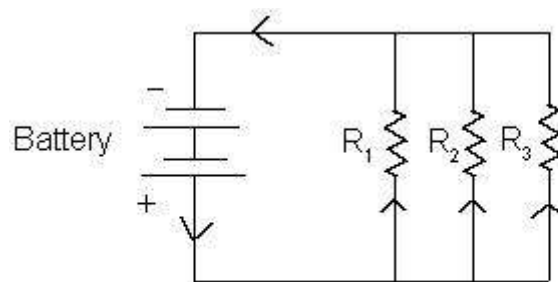

A parallel circuit with three resistors in parallel

The circuit shown below consists of two batteries and three resistors in series. In a series circuit the same amount of current flows through all parts of each circuit. The resistors are connected in series to obtain a greater resistance and it is equal to the sum of the values of each resistor, i.e.  $40\ \Omega$ . Two batteries are connected in series in this circuit to obtain the highest possible voltage which is the sum of the values of each battery, i.e.  $20\ \text{V}$ .

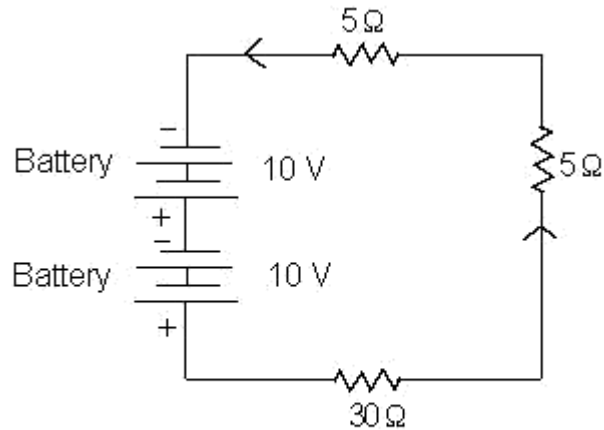

A circuit with three resistors in series (total=40 Ohms) and two batteries in series (total=20 V).

From the Ohm's law, the current flowing through this circuit will be:

$$I = \frac{E}{R} \text{ or } I = \frac{20}{40} = 0.5 \text{ A}$$

### Precaution

We should be careful while connecting batteries in series, because, the maximum current possible through the circuit is no greater than the greatest current that the weakest battery can deliver. If one of the batteries in the above example is weaker than the other and capable of passing only, say, 0.2 A, it will be overworked, may overheat and the voltage across the terminal will drop.

In this type of circuit, the voltage that can be obtained across each resistor is called the '**Voltage drop**'. From the Ohm's law, the voltage across each resistor can be calculated. The voltage drop across the 30Ω resistor is 15 V (0.5 x 30) and the voltage drop across the 5Ω resistor (each) is 2.5 V. Thus the sum of the voltage-drops is equal to the source voltage (2.5+2.5+15=20V).

### Internal Resistance of batteries

The battery might possess an internal resistance which is to be considered while calculating the various quantities in a circuit. If a 10 V battery has 1Ω internal resistance and connected across a 9Ω load resistor, the amount of current flowing through the circuit would be 1 A. A voltage drop of 1 V will take place inside the battery and hence the 10 V battery will produce only 9 V across its terminals when connected to the 9Ω load. When the circuit is open (no currents flowing through it), the voltage across the battery would be 10 V.

### Resistors in parallel circuit

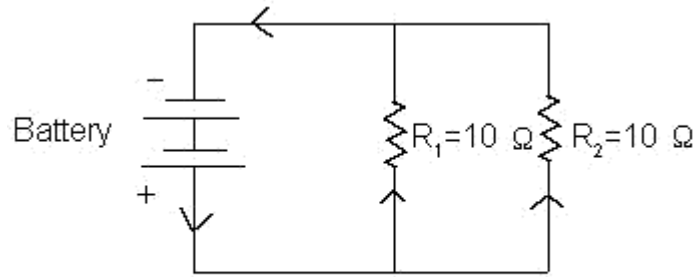

A parallel circuit with two resistors in parallel

The circuit shown above is a circuit where two resistors are connected in parallel across the voltage source. Obviously, there are two paths for the flow of current. One part of the current flows through  $R_1$  and the other part flows through  $R_2$ . Since total conductance  $S_t$  of a circuit is equal to the sum of all the conductances connected in parallel, the formula can be expressed as:

$$S_t = S_1 + S_2$$

$$\text{Or } S_t = 1/R_1 + 1/R_2$$

$$\text{Or } 1/R_t = 1/R_1 + 1/R_2$$

The above equation is made into a pair of fractions by placing a 1 over both sides,

$$\frac{1}{1/R_t} = \frac{1}{1/R_1 + 1/R_2}$$

or,  $R_t = \frac{1}{\frac{R_1 + R_2}{R_1 R_2}} = \frac{R_1 R_2}{R_1 + R_2}$

in the above circuit,  $R_t = \frac{10 \times 10}{10 + 10} = 5 \Omega$

### Calculation in a complex circuit

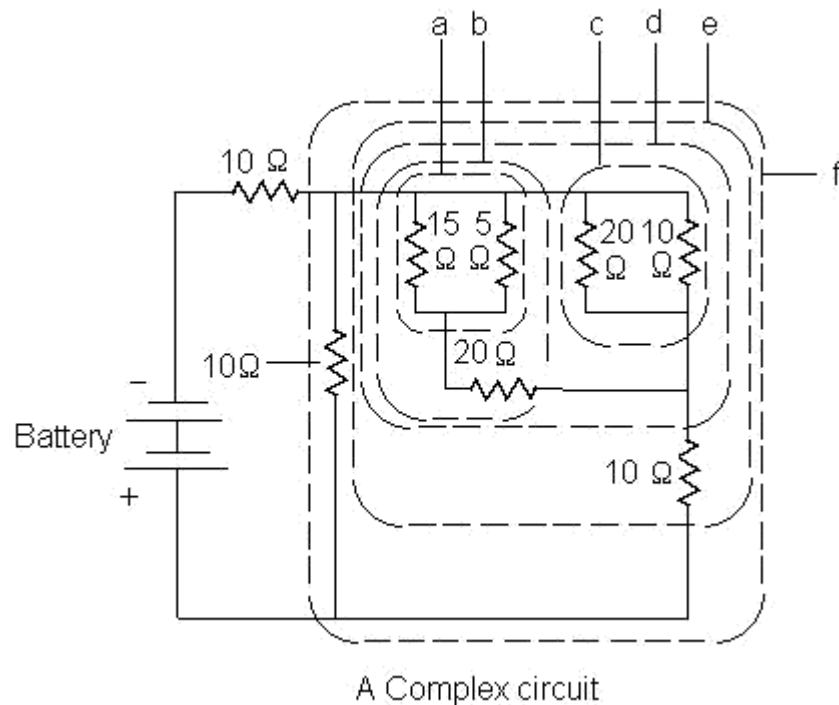

The circuit shown above seems to be a complex circuit. By looking at the arrangement of the resistors, their values can be computed in simple steps. As indicated above, calculate as per the steps shown [e.g. step (a), step (b).....]

**Step (a):**  $15\Omega$  &  $5\Omega$  resistors are arranged in parallel imparting a value equivalent to  $3.75\Omega$

**Step (b):**  $3.75\Omega + 20\Omega = 23.75\Omega$  (arranged in series)

**Step (c):**  $6.67\Omega$  (arranged in parallel)

**Step (d):**  $23.75\Omega$  &  $6.67\Omega$  are arranged in parallel. The equivalent value is  $5.20\Omega$

**Step (e):**  $5.20\Omega + 10\Omega$  in series, i.e.  $15.20\Omega$

**Step (f):**  $10\Omega$  and  $15.20\Omega$  are in parallel, i.e.  $6.03\Omega$  and

**finally,**  $10\Omega + 6.03\Omega$  are in series. The equivalent value is  $16.03\Omega$ .

### What are insulators?

The materials which do not allow the flow of electric current through them are called insulators. Glass, porcelain, dry air and dry wood are well known insulators.

## Inductors

### Self-Inductance

Self inductance is the property of a circuit whereby a change in current causes a change in voltage. Self-inductance is also more simply known as inductance. If 'L' is the inductance, then increasing the value of 'L' increases the amount of voltage that is induced in response to a change in current. Decreasing the value of 'L' decreases the amount of voltage that is induced in response to a change in current.

**Inductance** is measured in units of henries (h). Commonly used engineering units for inductance are- henry (1 h), millihenry (1mh=1 x 10<sup>-3</sup> h) and microhenry (1 μh=1x 10<sup>-6</sup> h).

**One henry is the amount of inductance that is required for generating one volt of induced voltage when the current is changing at the rate of one ampere per second.**

Inductance is the property of a coil when it is subjected to AC voltage. It results from the fluctuation of the current flowing through the circuit. When the current through the coil builds up, an expanding magnetic field also builds up cutting the turns of the coil resulting in the formation of a counter voltage in the coil which opposes the flow of the original current. This property of the coil is known as inductance. Since DC voltage remains constant (except for the instant when the circuit is closed, i.e. the instant when the switch is made on), there is no fluctuation in the magnetic lines of force produced across the turns of the coil and counter voltage is not generated. So a coil offers very negligible resistance (that due to the physical resistance) to the flow of DC current.

### Inductive reactance

Inductive reactance is the opposition to AC current flow that is caused by the presence of an inductor in the circuit. The symbol for inductive reactance is  $X_L$ . The unit of measure for inductive reactance is ohms ( $\Omega$ ). The amount of inductive reactance in a circuit is proportional to the *applied frequency* ( $f$ ) and the *value of the inductor* ( $L$ ).

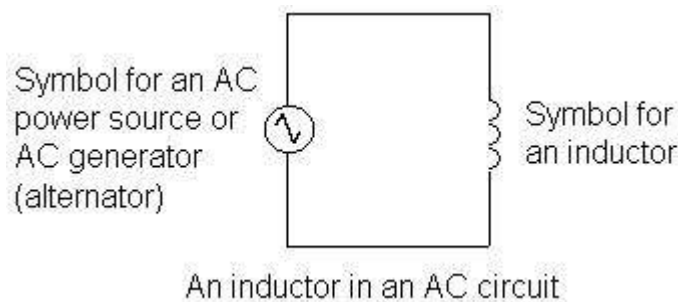

The equation for calculating the amount of inductive reactance in an ac circuit is given by:

$$X_L = 2\pi fL$$

where,  
 $f$  is the frequency of AC voltage and  $L$  is the inductance

The total inductive reactance of a series  $X_L$  circuit is equal to the sum of the individual reactance.

### Inductive reactance in series

$$X_{LT} = X_{L1} + X_{L2} + X_{L3} + \dots + X_{Ln}$$

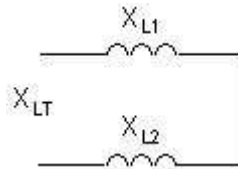

Where  $X_{LT}$  is the total inductive reactance and  $X_{L1}$ ,  $X_{L2}$ , ...,  $X_{Ln}$  etc. are the values of individual reactance.

### Inductive reactance in parallel

$$X_{LT} = 1 / (1/X_{L1} + 1/X_{L2} + 1/X_{L3} + 1/X_{Ln})$$

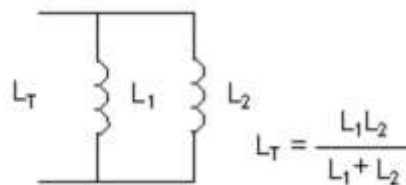

Inductive reactance is an AC version of resistance. In fact, you can use Ohm's Law by substituting  $X_L$  for  $R$ :

$$V_L = I_L X_L$$

where:

$V_L$  is the voltage across the inductor in volts

$I_L$  is the current through the inductor in amperes

$X_L$  is the amount of inductive reactance in ohms

The amount of inductive reactance ( $X_L$ ) changes proportionally with the applied frequency ( $f$ ):

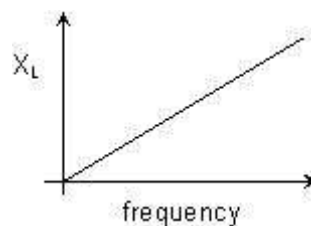

- Increasing the value of  $f$  causes  $X_L$  to increase.
- Decreasing the value of  $f$  causes  $X_L$  to decrease.

The amount of inductive reactance ( $X_L$ ) changes proportionally with the value of inductance ( $L$ ):

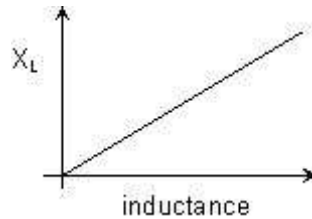

- Increasing the value of  $L$  causes  $X_L$  to increase.
- Decreasing the value of  $L$  causes  $X_L$  to decrease.

**Questions:**

1. What is the value of inductive reactance for an 0.1 H coil that is operating at 1 kHz?

Ans: 628  $\Omega$

Use the basic equation:  $X_L = 2\pi fL$

3. What value inductor is required for producing an inductive reactance of 10  $\Omega$  at 1.8 kHz?

Ans: 88.5  $\mu\text{H}$ .

Use this form of the basic equation:

$$L = \frac{X_L}{2\pi f}$$

4. At what frequency will a 150 mH inductor have an inductive reactance of 150  $\Omega$  ?

Ans: 159 Hz

Use this form of the basic equation:

$$f = \frac{X_L}{2\pi L}$$

4. What is the total inductive reactance of a circuit when  $X_{L1} = 150 \Omega$  and  $X_{L2} = 75 \Omega$  are in series?

Ans: 225  $\Omega$

## Equation to find out inductive reactance in a circuit with a number of inductors in parallel

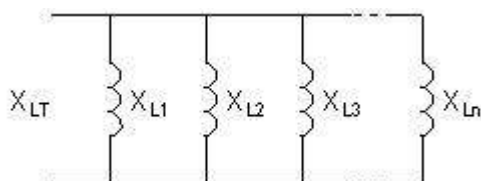

Use one of these inverse equations to determine the total inductive reactance of a parallel inductor circuit:

$$X_{LT} = \frac{1}{\frac{1}{X_{L1}} + \frac{1}{X_{L2}} + \frac{1}{X_{L3}} + \dots + \frac{1}{X_{Ln}}}$$

or

$$\frac{1}{X_{LT}} = \frac{1}{X_{L1}} + \frac{1}{X_{L2}} + \frac{1}{X_{L3}} + \dots + \frac{1}{X_{Ln}}$$

where:

$X_{LT}$  = total inductive reactance

$X_{L1}$  ,  $X_{L2}$  ,  $X_{L3}$  ,  $X_{Ln}$  = values of the individual reactance

The procedure for finding the total inductive reactance of a parallel inductor circuit is identical to finding the total resistance of a parallel resistor circuit.

The total reactance of two inductors in parallel can be found by applying the product-over-sum formula:

$$X_{LT} = \frac{X_{L1} X_{L2}}{X_{L1} + X_{L2}}$$

## Capacitor

Capacitor is a device used to store electrical energy and then release it as current into the circuit. Its property is just the reverse of an inductor. The capacitance of a capacitor is measured in Farad.

A capacitor has a capacitance of 1 farad if a 1 Volt difference in potential results in the storage of 1 coulomb of charge.

$$1 \text{ coulomb} = 6.28 \times 10^{18} \text{ electrons}$$

The capacitance is,  $C=Q/E$ ,

Where,            C is capacitance in farads,  
                      Q is the charge in coulombs,  
                      E is the voltage in volts.

Practically farad is a large unit. The smaller units are micro farads ( $\mu\text{f}$ ) and pico farads (pf).

$$1 \text{ Micro farad ( } \mu\text{f) = } \frac{1}{1,000,000} \text{ farad}$$

$$1 \text{ Picro farad ( pf) = } \frac{1}{1,000,000,000,000} \text{ farad}$$

When two metallic plates or conductors are separated by an insulator, also known as a dielectric, they behave like a capacitor. The conductors can be long or short piece of metal plate or any other conducting material. The insulator between the two conductors which is known as dielectric can be air, mica, wax-impregnated paper ceramic etc. The properties of a capacitor:

1. It stores energy in the form of electrical field
2. Capacitance is the property of an electric circuit that tends to oppose a change in voltage.
3. It passes A.C. and blocks D.C.

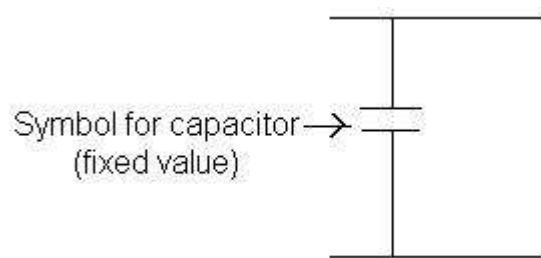

### Functioning of a capacitor

A capacitor when connected across a voltage source, an electrostatic field builds up between the metallic plates. The field builds up due to the accumulation of electrons on the negative plate and release of electrons from the positive plate until the capacitor voltage reaches its maximum. The capacitor will be in this charged state as long as it is connected to the voltage source. After removal of the voltage source, the capacitor can not loose its charge (theoretically, a perfect capacitor would hold the charge forever, but in practice, some of the charge leaks out), unless both the plates are connected with the help of a conducting path. When there is a conducting path, electrons from the negatively charged plate flows to the positive plate until both the plates are neutralized.

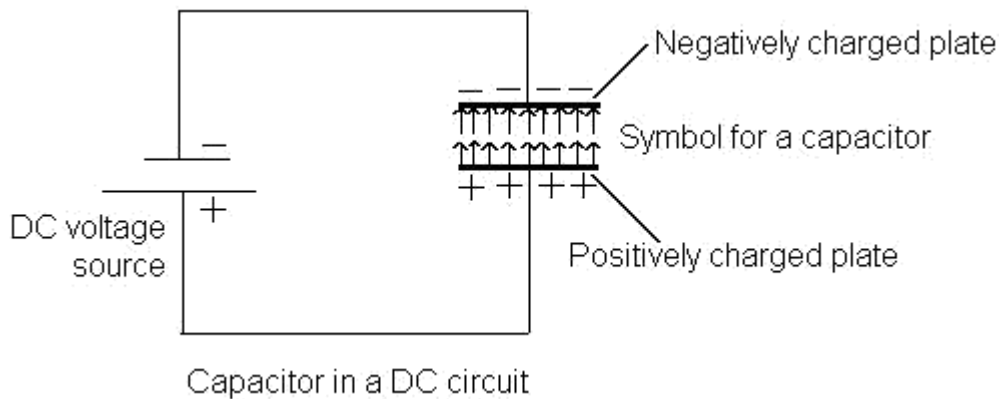

### Capacitor in a DC Circuit

In DC circuits, the capacitor will allow current to flow till it becomes fully charged, however since no current can flow through the dielectric material of the capacitor, no current flows after the capacitor gets fully charged.

### Capacitor in an AC Circuit

The AC voltage or current is fluctuating in nature. It is not only fluctuating but also changing the direction of flow, i.e. the polarity of the AC voltage source keeps on changing resulting in a charging and discharging of the capacitor. Unlike a DC circuit, here, current will continue to flow in the circuit (though the electrons don't cross the dielectric material of the capacitor).

### Capacitor in a varying DC circuit

If the voltage source is a varying DC, then also there is continual charging and partial discharging of the capacitor resulting in an AC current flowing through the circuit. In fact, the capacitor blocks the DC, but pass the AC component.

### Factors that affect capacitance

1. **Area of plates :** The larger the plates, the higher its capacity to store charges, i.e. **capacitance is directly proportional to the plate areas.**
2. **Space between the plates:** The closer the plates, higher is the capacity to hold charges, because, the electrostatic pull on the electrons collected at the negative side of the voltage source will be more. **Capacitance is inversely proportional to the spacing between plates.**
3. **Type of dielectric used:** Some materials are more dielectric than the others. Vacuum is the basic dielectric with which other materials are compared. It is said to be having a dielectric constant of 1. The dielectric constant of air is slightly more than this (1.0006). Dielectric constant is the ability of a material to permit the establishment of electric lines of force between oppositely charged plates. A dielectric (other than air) makes the positively charged surface of a capacitor repel more free electrons and negatively charged surface accept more electrons than when air is dielectric, thus increasing the capacitance. The dielectric constant of mica ranges from 5 to 9. Dielectric

constant of glass is 4.2. **Capacitance is directly proportional to the dielectric constant.**

A formula to determine the capacitance of a two-plate capacitor is:

$$C_{\text{pF}} = \frac{0.225 K A}{S}$$

Where

C= Capacitance in pF

K= dielectric constant

A= area of one of the plates, in inch<sup>2</sup>

S= spacing between plates, in inches

The above formula is valid for a two plate capacitor. For a multiplate capacitor, the formula is:

$$C_{\text{pF}} = \frac{0.225 K A (N-1)}{S}$$

Where N=number of plates in the capacitor

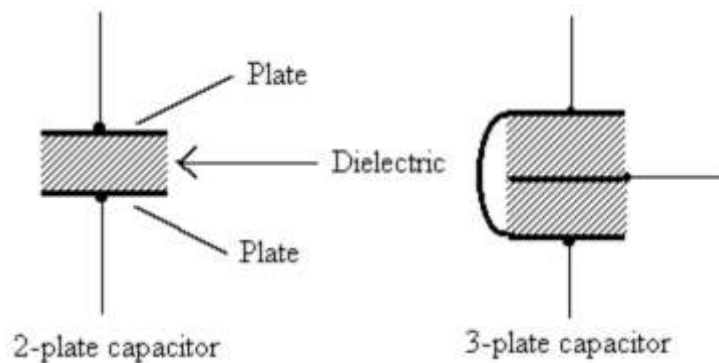

It is seen that a 3-plate capacitor has twice the plate area exposed and thus twice the capacitance.

### Quantity of charge in a capacitor

The quantity of charge in a capacitor can be found from the formula:

$$Q = CE$$

Where,

Q = charge, in coulombs (C)

C = capacitance, in F

E = voltage, in V

If a 0.1μF capacitor is charged by a 10 V source, the electron difference will be:

$$Q = 0.0000001 \times 10 = 0.000001 \text{ C or } 10^{-6} \text{ C}$$

$$10^{-6} C = 6.25 \times 10^{18} \times 10^{-6} = 6.25 \times 10^{12} \text{ electrons}$$

If the charged capacitor is disconnected from the voltage source, it will still retain the electron difference on its plates (assuming that there is no leakage). Now, if a similar uncharged capacitor is connected across the charged capacitor, electrons flow from the charged to the uncharged capacitor and it will get charged to 5 V as a result of distribution of half amount of electrons into it. Since the other capacitor lost half of its electrons, its voltage will be reduced to 5 V (now, both the capacitors will be having a voltage of 5 V each) from 10 V. If both the capacitors are reconnected in series, the total voltage-drop across them would become 10 V.

### Capacitive Reactance

Capacitive reactance is the resistance offered by a capacitor to the flow of AC through it. It is measured in ohms ( $\Omega$ ). The formula to calculate capacitive reactance in a circuit is:

$$X_c = \frac{1}{2\pi fC}$$

Where  $X_c$  = reactance, in  $\Omega$

$f$  = frequency, in Hz

$C$  = capacitance, in F

### Questions:

1. Find out the reactance of a  $0.002 \mu\text{F}$  capacitor to a frequency of 2,000 kHz.

Solution:

$$X_c = \frac{1}{2\pi fC} = \frac{1}{6.28 (2,000,000) 0.000000002} = \frac{1}{0.02512} = 39.81 \Omega$$

### Capacitors in parallel

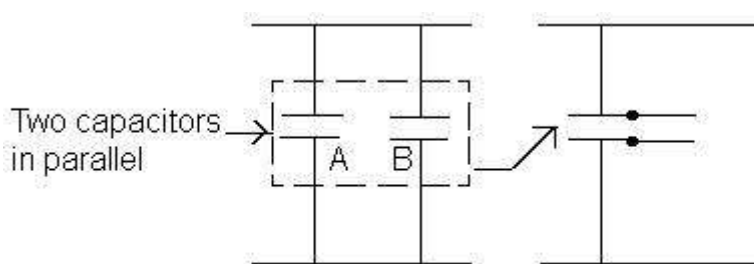

Two similar capacitors have twice the capacitance of one alone

Capacitors can be connected in parallel to obtain a greater value. The formula is:

Total capacitance of capacitors in parallel,  $C_t = C_1 + C_2 + C_3 + \dots + C_n$

**While connecting the capacitors in parallel, it should be noticed that the voltage applied on them does not exceed the voltage rating of the capacitor with the minimum voltage rating.**

## Capacitors in series

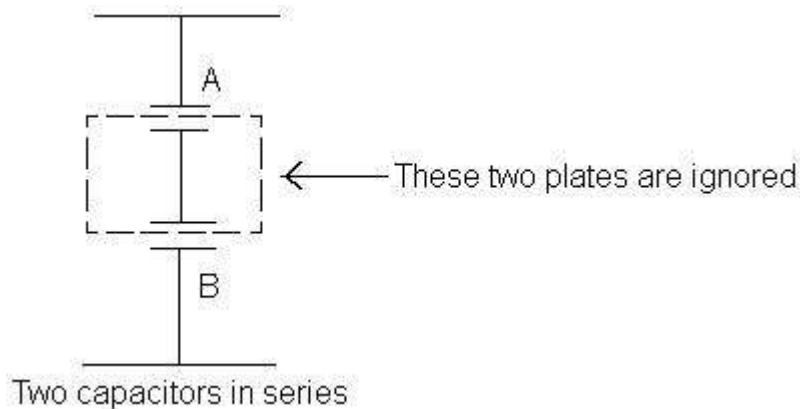

As shown above, when two capacitors are connected in series, the bottom & top plates of the respective capacitors are ignored and consequently combined effect of two capacitors of equal value is to simulate a single capacitor with half the value of a single capacitor, i.e. if two 10  $\mu\text{F}$  capacitors are connected in series as shown above, we will get an effective capacitance of 5  $\mu\text{F}$ . This is because the circuit sees only two plates (plate a & b) with a dielectric distance of twice that of a single capacitor (capacitance decreases when distance between plate increases). It is to be noted that when capacitors of different voltage ratings are connected in series, the voltage that can be applied to them can be equal or less than the total voltage obtained by adding voltages of each capacitor, alternatively, we can say that when capacitors in series are connected across voltage source, the sum of the voltage-drops across each of them will always equal the source voltage.

The formula to calculate the total capacitance of a number of capacitors connected in series is:

$$C_{\text{total}} = \frac{1}{\frac{1}{C_1} + \frac{1}{C_2} + \dots + \frac{1}{C_n}}$$

## Types of capacitors

There are fixed value capacitor as well as variable value capacitors available for electronics work. Paper, mica, ceramic and polyester capacitors have fixed values.

### Paper capacitor

Paper capacitors are made by rolling two metal foils with a strip of paper and then impregnating with a dielectric between them. For high voltage applications, several layers of papers are used to separate the metallic foils. They are not suitable for use at frequencies above 1 MHz, which virtually restricts their application to audio frequency (AF) circuits. They are available in capacities from **0.05  $\mu\text{F}$  up to 1 or 2  $\mu\text{F}$**  with working voltages from 200 to 1000 volts.

### Mica capacitor

Mica is used as a dielectric between the metallic plates in this type of capacitors.

These capacitors have excellent high frequency response.

### **Ceramic capacitor**

In this type of capacitor, ceramic is used as a dielectric which has a high dielectric constant. Ceramic capacitors have good stability with regards to temperature and voltage changes. They are widely used in miniaturized audio frequency (AF) and radio frequency (RF) circuits. Their capacities ranges from **1pF to 1 μ F** with high working voltage.

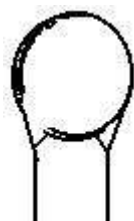

A Disc ceramic capacitor



A Tubular Ceramic capacitor

### **Polyester film capacitor**

In this type of capacitors polyester is used as a dielectric to impart a high breakdown voltage. Their capacities ranges from **0.01 μF up to 2.2 μ F**. Their low inherent inductance makes them suitable for coupling and decoupling applications.

### **Polystyrene capacitor**

These capacitors are made from metallic foil interleaved with polystyrene film, usually with fused polystyrene enclosure to provide high insulation resistance. They provide good stability and reliability at high radio frequencies because of their low inherent inductance and low series resistance. Their values range from from **10 pF to 100,000 pF**, but working voltage generally falls substantially with increasing capacity (as low as 60 volts for a 100,000 pF polystyrene capacitor).

### **Electrolytic capacitor**

An electrolytic capacitor consists of an aluminum-foil positive plate immersed in a solution called an electrolyte (ionizable solution capable of carrying current). The aluminum foil is the positive plate, and the electrolyte is the negative plate, if a liquid can be called a plate. To make an electrical connection to the liquid, another aluminum foil is placed in the solution. To prevent the two foils from touching each other, a piece of gauze is placed between them. The +ve foil is surrounded by a thin oxidized film formed due to application of a particular voltage which acts as the dielectric. Electrolytic capacitors can not be used in AC circuits. Their values range from **1 μ F to 4700 μ F** or more with working voltage ranging from 10 volts dc up to 500 volts.

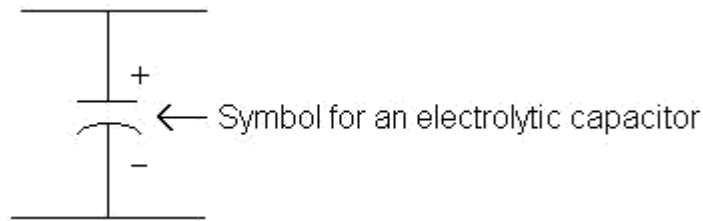

### Variable capacitors

Variable capacitors are widely used in radio frequency work where it is required to change the value of the capacitor in order to tune the circuit to a particular frequency. Usually, air is used as a dielectric in this type of capacitor. The capacitance is made to vary either by changing the distance between the plates or by changing the plate area exposed. This type of capacitor may consist of two plate or more than two plates. Metallic gang capacitors and button trimmers are the most common example of variable capacitors. In a trimmer the two metallic plates are made to vary in their distance with the use of a screw.

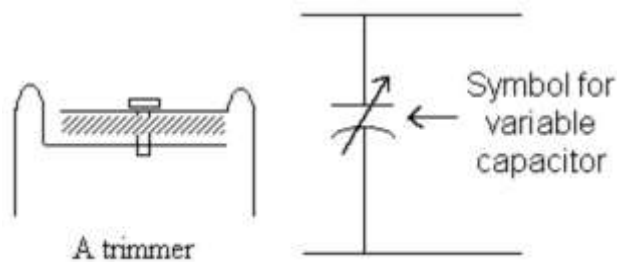

### Electrical Impedance

Electrical impedance is the total opposition to current flow in an AC circuit. It takes into account all sources of opposition. Since it is the total opposition, impedance is measured in ohms, just as resistance and reactances are. If an inductor and resistance are connected in series with a source of A.C., the impedance of the circuit is:

$$Z = \sqrt{X_L^2 + R^2}$$

If  $X_L = 4\Omega$  and  $R = 3\Omega$

Therefore,

$$Z = \sqrt{16+9}$$

$$= 5\Omega$$

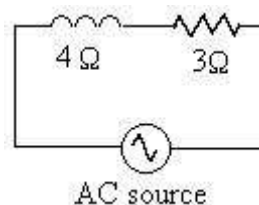

The impedance of a series R-L circuit can never be equal to or greater than the

sum of  $X_L$  and  $R$ , nor can it be equal to or less than either  $X_L$  or  $R$ .

### Inductance and Capacitance in Series

When an inductor and a capacitor are connected end to end, a series L-C circuit is formed. If the inductor is a pure inductor and capacitor, a pure capacitor, then the circuit has no D.C. resistance which is practically impossible. There is always some resistance present in the circuit. Inductor has inductive reactance,  $X_L$  and capacitor has the capacitive reactance,  $X_C$ . The net resistance present in the circuit is negligible.

If the circuit has an inductance  $L$  of 1 henry in series with a capacitor  $C$  of 10  $\mu\text{F}$  and the applied voltage  $E$  is 100 volts and frequency is 50 Hertz.

Then,

$$\text{Inductive reactance } X_L = 2\pi fL = 6.28 \times 50 \times 1 = 314$$

$$\Omega \text{ Capacitive reactance, } X_c = \frac{1}{2\pi fC} = \frac{1}{6.28 \times 50 \times 0.00001} = \frac{1}{0.00314} = 318.5 \Omega$$

The impedance of such circuit is the difference of inductive reactance and capacitive reactance.

$$Z = X_C - X_L = 318.5 - 314 = 4.5 \Omega$$

If  $X_L$  is greater than  $X_C$  then the impedance is  $X_L - X_C$ .

### Resonant frequency

Resonant circuits make it possible to select one frequency from all others. For example, there are hundreds of radio stations that broadcast signals strong enough to be received by your radio receiver. The tuning circuit of the radio receiver accomplishes the task of discarding all other signals but to allow only the desired signal to be processed. **The single frequency at which the circuit responds best is called the resonant frequency of the circuit.** Resonance occurs when the inductive reactance becomes equal to capacitive reactance or  $X_L = X_C$ .

It can be achieved by either varying capacitance or inductance. In a radio receiver, it is achieved by varying the value of the variable capacitor. A series resonant circuit offers very little resistance when the circuit operates at the resonant frequency. High current is permitted to flow through the circuit.

### Parallel Resonant Circuit

In the circuit diagram shown below, the part of the circuit between the points 'a' and 'b' is called a 'tank' because the resonant frequency will be captured and held there while all other frequencies are allowed to flow through it. So if the AC source is producing AC current at the resonant frequency, that current is blocked by the tank. The current is not permitted to travel from 'a' to 'b' through the tank. But when the

AC source is producing current at any other frequency, the current can flow from 'a' to 'b' with little opposition.

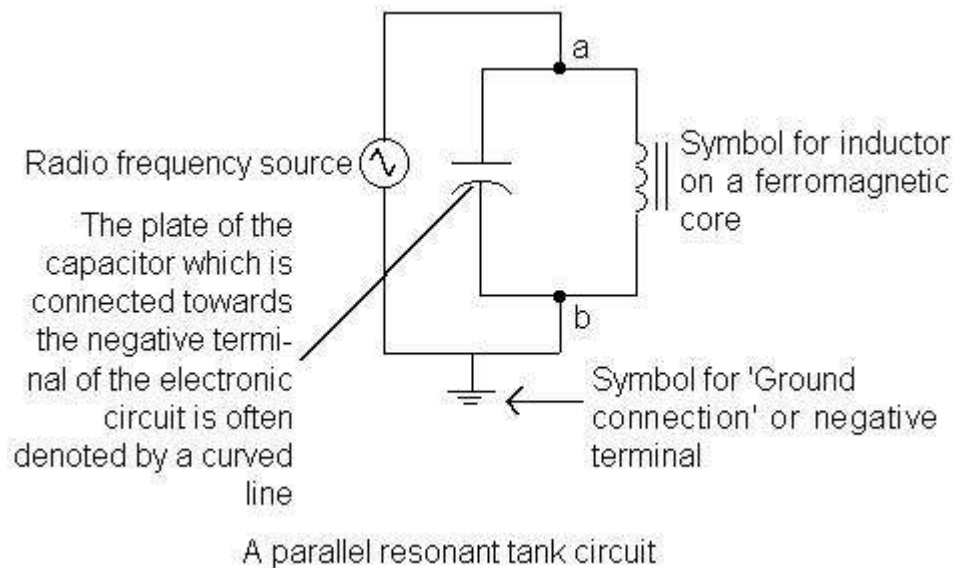

### Tuning Circuit

In a radio receiver, the selection of the desired frequency out of hundreds of other frequencies is achieved by the use of resonant circuit. The resonant circuit basically consists of an inductor and a capacitor. The frequency of resonance is usually achieved by changing the capacitance of the variable capacitor.

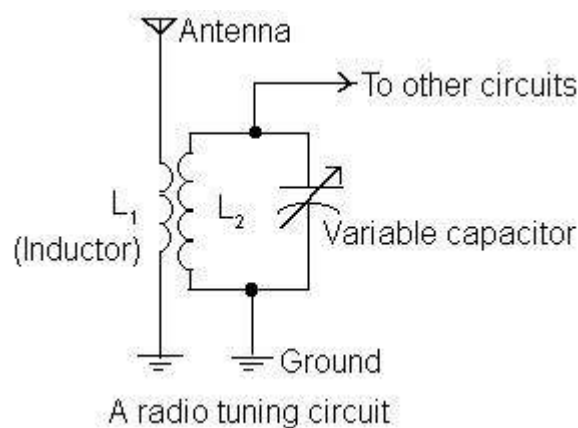

In the tuning circuit shown above, all the frequencies captured by the antenna are passed to ground through the primary coil  $L_1$ . They will try to cause current flow in the tank circuit, but only the resonant frequency will be successful in creating a current flow. The information it carries will be sent to the other radio circuits while the non-resonant frequencies are practically ignored.

In the circuit shown above, the condition of series resonance is present but is not apparent. In this circuit the transformer secondary coil has a capacitor across it with a reactance of the secondary, forming a resonant circuit. At first glance it appears to be a parallel-resonant circuit. The primary coil, however, is inducing an AC voltage into each turn of the secondary coil. Theoretically, the secondary may be considered

to have a source of AC inserted in series with its turns.

## Filtering

Resonant circuits are used to filter out the desired frequency. A series resonant circuit allows to pass its resonant frequency while the parallel resonant circuit (called the tank circuit) blocks the flow of its resonant frequency

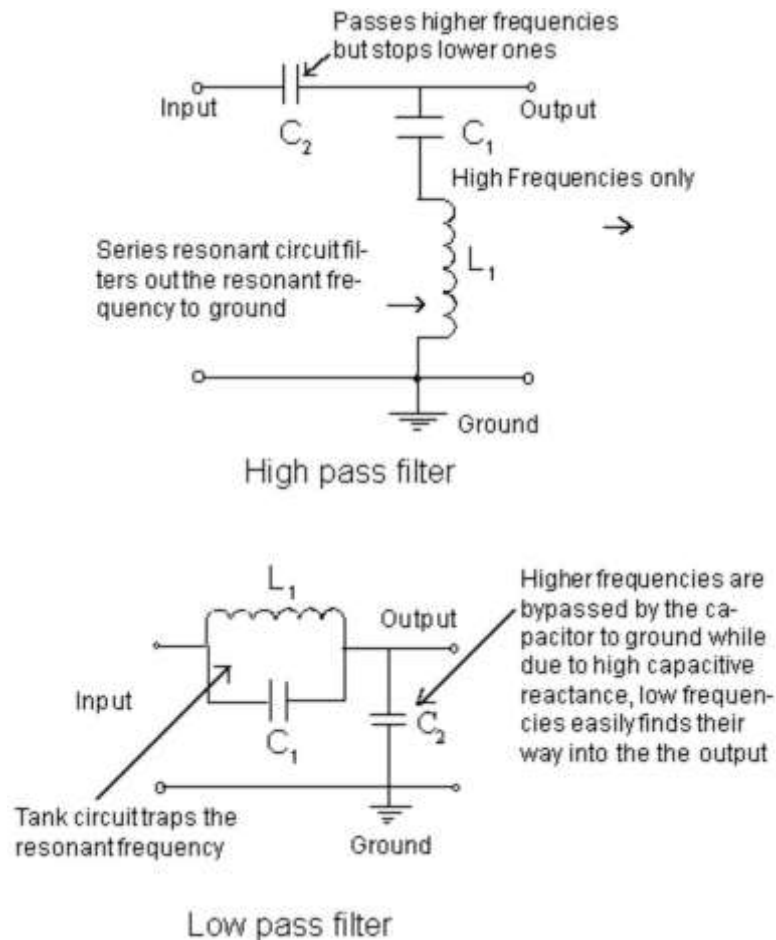

## 'Q' of a circuit

The term 'Q' is applied to AC circuits in which inductance and capacitance are involved. It in fact express the 'quality' of the inductor or capacitor and since lesser the ohmic resistance of the coil (inductor), more perfect inductor the coil is, with little loss. 'Q' can be found from the formula:

$Q = X_i / R$  (in case of coil); where  $X_i$  = inductive reactance,  $R$  = Ohmic

resistance. Again,

$$X_i = 2\pi fL$$

Where,

$f$  = frequency,  
 $L$  = inductance

Therefore,  $Q = 2\pi fL / R$  ; this shows that the same coil or inductor possesses high 'Q' at higher frequency.

### **Skin effect**

A phenomenon called 'Skin effect' also causes loss of efficiency of a coil or inductor. It is observed that at higher frequencies, electrons flow nearer to the surface of the conducting wire; since the usable cross-sectional area lessens, the ohmic resistance increases resulting in a lower 'Q'.

Prevention of 'Skin effect'

- (i) By using large diameter wire.
- (ii) By silver-plating of the wire used.
- (iii) Using fewer turns while making the coil, but increasing the core permeability; e.g. using powdered iron core.
- (iv) By using 'Litzendraht wire', an insulated multistrand wire. Several thin strands have more surface for a given wire diameter than does a solid wire (Litz wire is effective only up to about 1 MHz)

## **B. Thermionic Emission & Valves**

An electric current can also flow in a gas. A voltage applied across a gas-filled tube causes ionization of the gas: free electrons stream towards the plate with the positive potential, colliding with the atoms in their way and detaching electrons from their orbits. The positive ions move toward the opposite end of the tube.

The most common material used in the construction of a vacuum tube envelope is glass. The electrode leads pass through a glass bead sealed into an eyelet. The electrodes in a vacuum tube are supported by insulators such as mica and a variety of ceramics. The electrodes themselves are commonly made from metals such as nickel, copper, aluminum, molybdenum, and tungsten.

In thermionic valves the electrons move in a vacuum. An example of such a device is the diode. The envelope of a diode houses two main parts which are also called the anode (or plate) and the cathode. Near the cathode there is a filament or miniature electric heater which heats the cathode. Most tubes employ heater-cathodes. A heater-cathode consists of a metal cylinder coated with special oxides that liberate great quantities of electrons when heated to a relatively low temperature. In this case an "electron liquid", consisting of electrons that move chaotically in the very body of the cathode, between its atoms, begin to "boil". This phenomenon is known as 'electronic emission'. As a result of this emission, a cloud of "electron gas" is formed round the cathode. If the cathode is now connected to the negative terminal of a voltage source and the anode, to the positive terminal, the anode will begin attracting electrons from the cloud, "drawing" them away from the cathode, and a current will flow inside the diode. Freedom for the electron proves very short-lived: no sooner

does it escape from the cathode it is immediately attracted by the anode.

A diode is in fact a one-way valve. When the negative terminal of the voltage source is connected to the anode and the positive terminal to the cathode, the electrons will not be able to escape the cathode, because it attracts them. But even those that do escape have nowhere to fly in particular: previously they were attracted by the anode, now it forces them back to the cathode. With such a connection no current flows through the diode. This property of the diode is employed for converting the alternating current to direct current which is called rectification. The current flowing through a diode is called the plate current. The flow of plate current can be controlled by two ways: by varying cathode temperature; and by changing the applied voltage (called the plate voltage). But cathodes are designed to operate most efficiently at one particular temperature. An increase in plate voltage results in an increase in plate current. But after a certain point, further increase in plate voltage will not cause any corresponding increase in the plate current. This point is called the saturation point.

### Diode valve as a rectifier

As shown in the circuit given below, the source of plate voltage in the plate circuit is a transformer providing an alternating voltage to the plate. During one half cycle, the plate end of the transformer-secondary winding may be positive and the cathode end negative. On the next half cycle the plate end will be negative and the cathode end positive. As described above, the diode allows only one half cycle of the emf to produce current in the circuit. With ac plate voltage the plate current is pulsating dc. This one-way-gate effect is a main use of diodes. A diode is also called a rectifier.

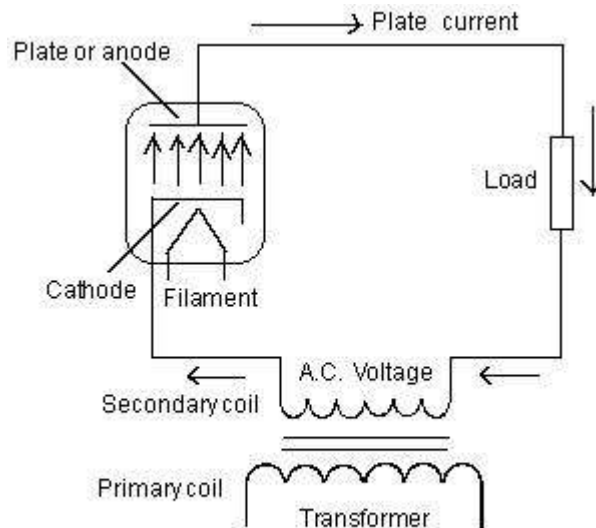

A diode valve as a rectifier

### Triode Valve

The introduction of a third electrode (control grid) between the cathode and the anode of a diode makes it a triode. In the triode, current is controlled by means of a voltage applied between the cathode and the grid. With a high negative grid potential (with respect to the cathode), the grid becomes a barrier for the electrons. They will "crowd" in the space between the cathode and the grid; the valve will be cut off, since

no current will flow from the cathode to the anode. With a positive grid potential, the grid will help the anode, since its positive potential will be added to that of the anode. A heavy current will flow through the valve. However, with too high a positive grid potential the grid may turn from a helper of the anode into its competitor: some electrons will be drawn to it and will not reach the anode. In this case a harmful grid current appears in the valve. That is why in normal operation the grid is made to vary only more or less negatively.

### Amplification factor of a triode valve

In the circuit shown below, the voltage ( $-E_g$ ) in the grid circuit is  $-8$  V. Plate voltage ( $+E_p$ ) is 200 V. Plate current is 3mA. By increasing  $+E_p$  by 40 V it is found that plate current increases from 3 to 7 mA. Returning to the original values, Grid voltage ( $-E_g$ ) is  $-8$  V,  $+E_p=200$  V, and  $I_p=3$ mA, it is found that if the  $-E_g$  value is reduced by 2 V, from  $-8$  to  $-6$  V, the  $I_p$  will again rise from 3 to 7 mA. This indicates that the same  $I_p$  change can be produced either by changing the  $E_p$  by 40 V or by changing the  $-E_g$  by 2 V. This controlling ratio of 40:2 is equal to 20. The tube is said to have a  $\mu$  (mu) or amplification factor of 20. Thus the grid is found to be 20 times more effective in changing plate current than the plate voltage.

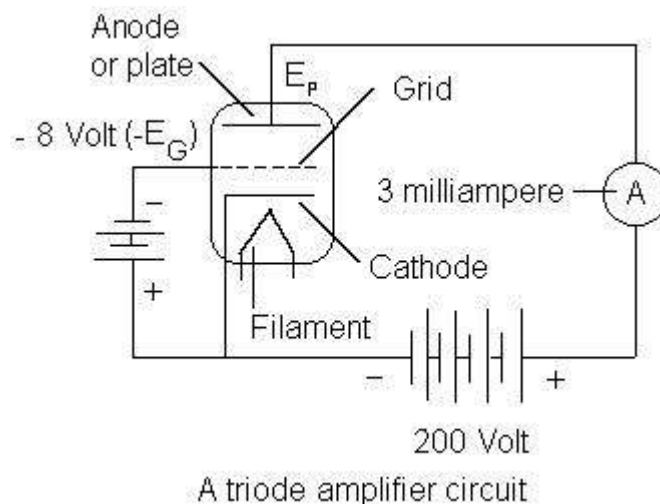

### Triode as an amplifier

In a theoretical circuit comprising a microphone, a transformer, a triode valve with a load resistance, the microphone induces a small ac voltage into the secondary of the transformer and between grid and cathode. With no signal applied to the grid and with 100 V from the plate supply, the dc voltage- drop across the load resistor  $R_l$  might be 75 V. As the input signal reaches a peak of 1V negative, the current in the plate circuit will decrease. The voltage drop across the plate-load resistor might decrease by 12 V, to 63 V across the  $R_l$ . As the grid voltage swings to 1 V positive, the plate current will increase, until there is a voltage drop of perhaps 87 V across the load resistor. As grid voltage varies from  $-1$  V to  $+1$  V (a 2 V peak to peak variation), the voltage across the load resistor varies between 87 and 63, i.e. 24 V. The voltage ratio of 2:24 indicates that across the plate load resistor, the voltage variation is 12 times more than the variation between the grid and the cathode.

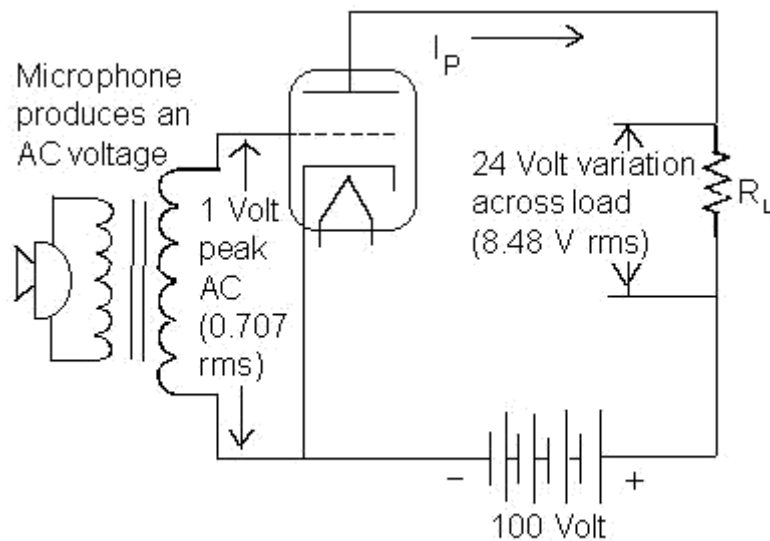

A simple audio amplifier circuit using triode valve

### Bias voltage

In the circuit described above, the grid was driven negative and positive alternately. But this creates distortion. To avoid the distortion, in a practical circuit, the grid may never be allowed to become positive and thus there is no grid current ( $I_g$ ) from the cathode. This is accomplished by adding a dc voltage source in series with the grid-cathode circuit. The negative potential is applied to the grid through the transformer, and the positive potential to the cathode. The negative dc voltage added in series with the grid circuit is known as the bias voltage. If a negative 10 V bias is enough to produce plate-current cutoff with a given plate voltage, then a possible bias voltage would be half of this, i.e. 5 V for a class A amplifier. It can accommodate a peak ac emf of 5 V from the secondary of the grid-circuit transformer and neither cutoff the plate current nor drive the grid into positive region.

### C. Semiconductors: Diodes & Transistors

In the early days of electricity there were only two groups of material: insulators and conductors. Insulators are materials which do not allow the flow of electric current through them. Glass, porcelain, dry air and dry wood are well-known insulators. Metals are known to be good conductors, with copper and silver among the best. The conductivity of a particular material depends on the number of free electrons present in it.

There is another group of material known as semiconductors. Semiconductors like germanium and silicon are bad conductors of electricity in their purest form. But when certain impurities (iridium or arsenic, which have a slightly different atomic structure from that of germanium or silicon) are added in the form of carefully controlled quantities, either an increase of free electrons or deficiency of electrons results. A semiconductor is called an **n-type semiconductor** where conduction takes place by reason of excess free electrons. A semiconductor is called a **p-type semiconductor** where conduction takes place due to freely moving 'holes' (positively charged) which replace electrons displaced by random electron movement in the material.

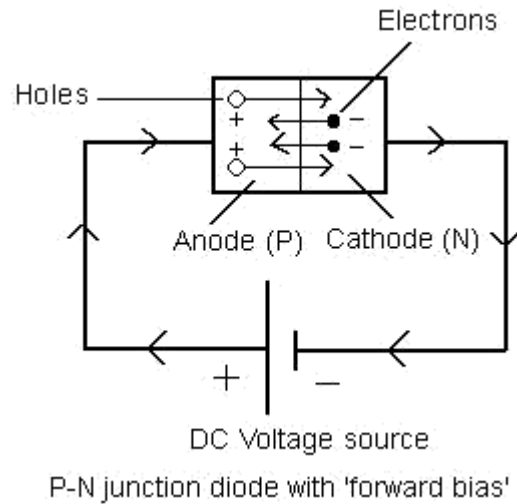

When pieces of p-type and n-type semiconductors are joined together, a p-n junction results. Flow of electric current through such a junction is possible only when the positive pole of the battery (voltage source) is connected to the p-type semiconductor and the negative pole to the n-type semiconductor. This is called the “**forward biased**” condition.

Symbol for a semiconductor diode

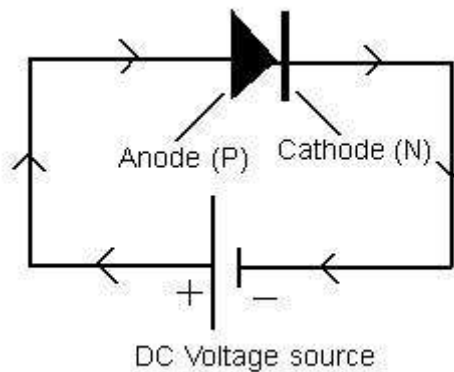

A forward biased semiconductor diode

In this condition, positively charged holes are repelled by the battery voltage towards the junction between p and n type material. Simultaneously, the electrons in the n-type material are repelled by the negative battery voltage toward the p-n junction. Despite the presence of a potential barrier at the p -n junction, which prevents electrons and holes from moving across and combining, under the influence of the electric field of the battery the holes move to the right across the junction and the electrons move to the left. As a result, electrons and holes combine and for each combination of that takes place near the junction, a covalent bond near the positive battery terminal breaks down, an electron is liberated and enters the positive terminal. This action creates a new hole which moves to the right toward the p-n junction. At the opposite end, in the N-region near the negative terminal, more electrons arrive from the negative battery terminal and enter the n-region to replace the electrons lost by combination with holes near the junction. These electrons move toward the junction at the left, where they again combine with new holes arriving there. As a consequence, a relatively large current flows through the junction. The current

through the external connecting wires and battery is due to that of the flow of electrons. If, however, the polarity of the battery is reversed, i.e., the positive terminal is connected to n-type semiconductor and the negative terminal of the battery to the p-type semiconductor, the p-n junction will block the electron flow by building up a voltage barrier at the junction. The holes are now attracted to the negative battery terminal and move away from the junction because of the attraction of the positive terminal. Since there are effectively no hole and electron carriers in the vicinity of the junction, **current flow stops almost completely**. The diode is now in reverse biased condition. This type of device is called a “**solid state diode**” or a semiconductor.

### Use of Semiconductor diode

By exploiting their property of one way flow of electric current, they can be utilized to convert alternating current to direct current (known as rectification). Without adequate filtering, the resultant d.c. is pulsating in nature. However, it will be appreciated that a diode will work in both a dc and an ac circuit. An example of the use of a diode in a dc circuit (say output side of a dc power supply) to eliminate any possibility of reverse polarity voltage surges occurring which could damage transistors in the same circuit.

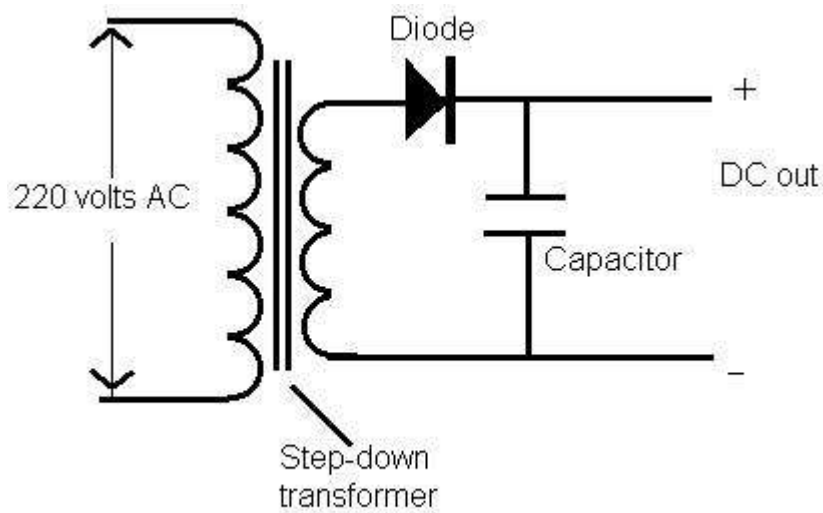

A basic half-wave rectifier circuit

The circuit shown above is a basic half-wave rectifier circuit passing one half of each AC cycle as DC and suppressing the other half cycle. The purpose of the capacitor is to maintain the DC voltage output as far as possible by discharging on each ‘suppressed’ half cycle. The DC output in this type of circuit is not smooth having a ‘ripple’ at the AC frequency.

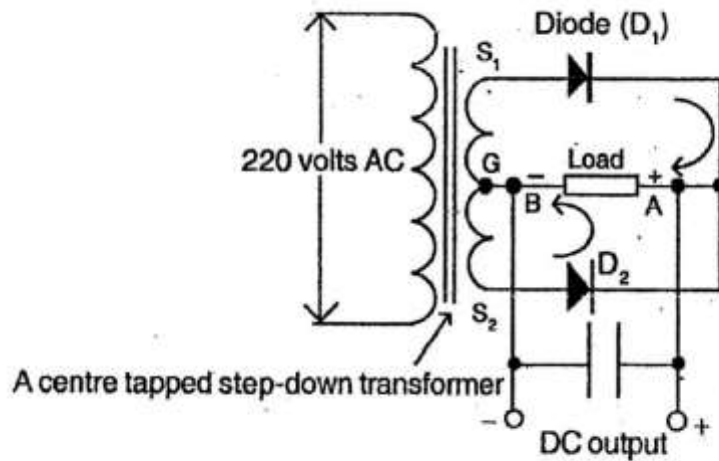

A basic full-wave rectifier circuit

The circuit shown above is that of a simple full wave rectifier whose secondary voltage is halved (because of the center tapping), but the current that can be drawn is doubled. The capacitor charges and discharges alternately to produce a smoother DC supply. The 'ripple' will still be there which will be equal to twice the AC frequency.

The usual form of full-wave rectifier circuit is the bridge rectifier shown below. This gives approximately the same no-load voltage as a half-wave rectifier with the advantage of full -wave rectification and better smoothing. A single high value electrolytic capacitor is used for smoothing.

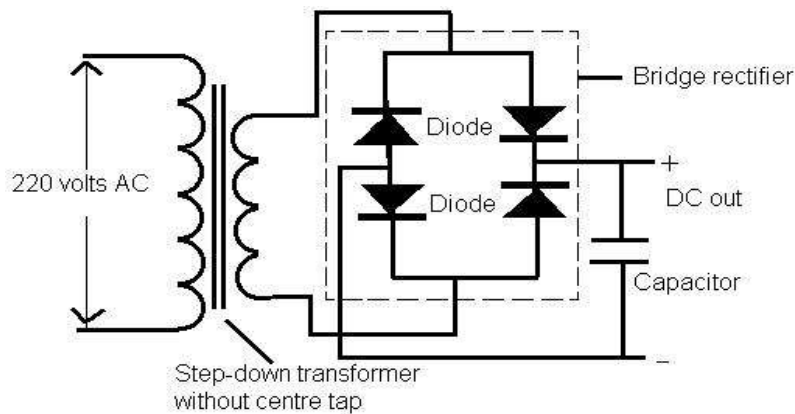

A practical full wave power supply

## Transistors

The simplest of the transistors are of two types-either **p-n-p** or **n-p-n**. Two p-n junction diodes can be sandwiched back to back to form a p-n-p or n-p-n junction transistor. But in a practical transistor, the center or n-type portion of the sandwich is extremely thin in comparison to the p-regions. In the 1<sup>st</sup> illustration, **both the p-n**

**junctions are reverse biased.**

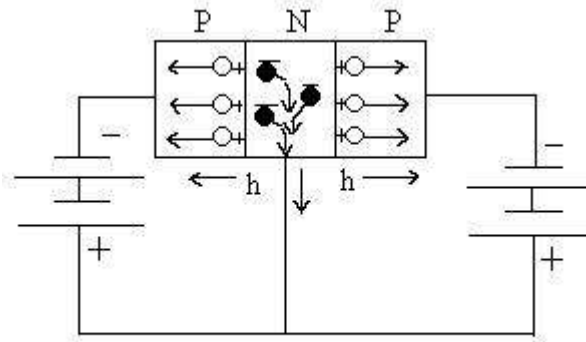

Non-Conducting P-N-P Junction

In this type of connection, holes in the each of p -region are attracted towards the negative battery terminal and the mobile electrons in the n-region are initially moved away from both junctions in the direction of the positive battery terminal. Due to the displacement of holes and electrons, **there will be no current flow in the external circuit.**

In the **2nd illustration** , one of the **p- n junctions is forward biased**, while the **other is reversed biased**. In a transistor, the middle layer (here n-region) is called the **base**, the forward biased p-n junction is called the **emitter junction** and the reverse biased p-n junction is called **collector junction**. Due to the positive potential at the emitter junction, the holes in the p-region cross into the n-region (**the base**). But this region is very thin and there are very few electrons with which holes can combine. So, majority of the holes drift across the base into the collector junction. About 5 per cent of them are lost in the base region as they combine with electrons. For each hole that is lost by combination with an electron in the base and collector areas, a covalent bond near the emitter electrode breaks down and a liberated electron leaves the emitter electrode and enters the positive battery terminal. The new hole that is formed then moves immediately toward the emitter junction, and the process is repeated. Thus, a continuous supply of holes are injected into the emitter junction, which flow across the base region and collector junction, where they are gathered up by the negative collector voltage. The flow of current within the p-n-p transistor thus takes place by hole conduction from emitter to collector, while conduction in the external circuit is due to the flow of electrons.

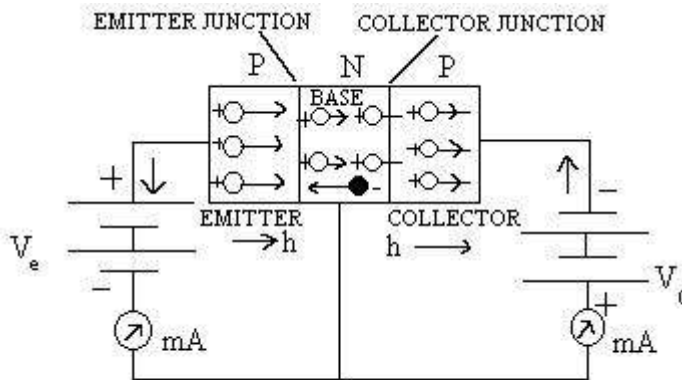

Basic connection of P-N-P Junction transistor

**Because of the reverse bias no current can flow in the collector circuit, unless current is introduced into the emitter.** Since a small emitter voltage of about

0.1 to 0.5 volt permits the flow of an appreciable emitter current, the input power to the emitter circuit is quite small. As we have seen, the collector current due to the diffusion of holes is almost as large as the emitter current. Moreover, the collector voltage can be as high as 45 volts, thus permitting relatively large output powers. **A large amount of power in the collector circuit may be controlled by a small amount of power in the emitter circuit.** The power gain in a transistor (power out/power in) thus may be quite high, reaching values in the order of 1000.

### Current gain of transistor ( $\alpha$ )

The ratio of **collector current** to **emitter current** is known as **alpha** ( $\alpha$ ), i.e.

$$\alpha = \frac{I_C}{I_E} = \frac{\text{Collector current}}{\text{Emitter current}}$$

It cannot be higher than 1. It is the measure of possible current amplification in a transistor.

Beta ( $\beta$ ) is another constant defined as ratio of collector current to base current. If  $I_E$  is the emitter current, and  $I_C/I_E = \alpha$ , then  $I_B$ =base current= $1-\alpha$ , i.e.,

$$\beta = \frac{I_C}{1-\alpha}$$

### Transistor Symbols and Connection

When transistors are operated as amplifier, **three different basic circuit connections** are possible: (a) Common-base, emitter input; (b) common-emitter, base input; and (c) common-collector, base-input.

Regardless of the circuit connection **the emitter is always forward biased** and **collector is always reverse biased.**

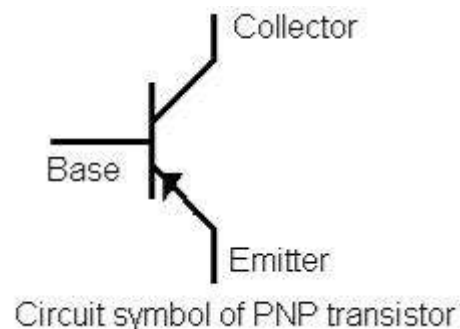
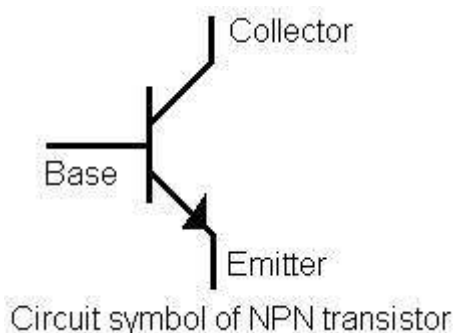

Described below is a '**common emitter, base-input**' basic transistor amplifier circuit using a PNP transistor. The transistor is in **common-emitter configuration**. It needs two separate supply voltages--**one for base bias** and the **other for the collector**. In the first diagram, two separate batteries are used. But the voltages can also be provided by a single supply (**as shown in the second diagram**) taken to the common connection (the emitter) and the collector; and tapping the collector side to apply the necessary forward bias voltage to the base dropped a bias resistor.

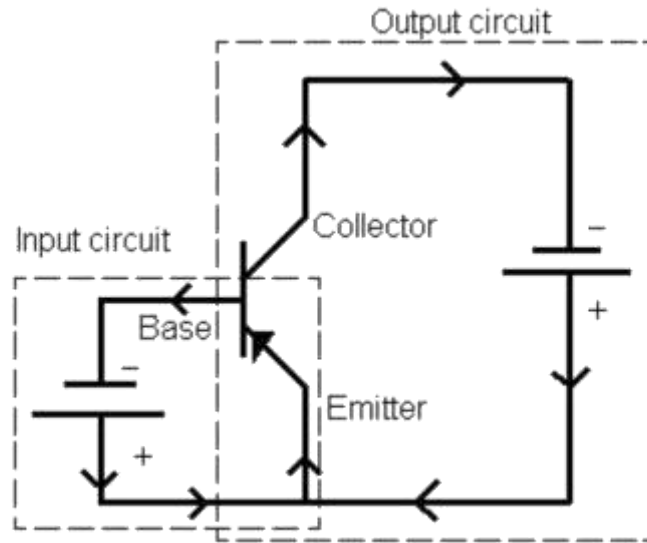

A common emitter amplifier circuit using PNP transistor

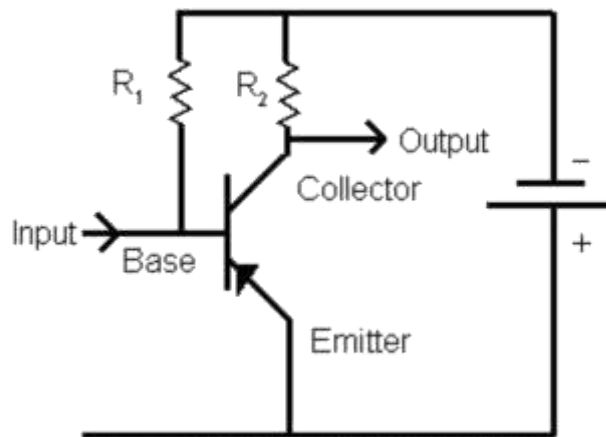

A common emitter amplifier circuit using a PNP transistor with a single power supply

In this type of amplifier circuit, the collector current is fed through an output load ( $R_2$ ). The biasing voltage to the base is provided through the resistor  $R_1$  is of the order of 0.1 to 0.2 volts for germanium transistors; and about 0.6 to 0.7 volts for silicon transistors. This type of biasing is called as *current biasing*. A relatively small *base current* can instigate a very much larger *collector current* (or, more correctly, a **small input power** is capable of producing a much **larger output power**). In other words, the transistor works as an amplifier. However, this type of circuit is not very stable. To provide stability, another type of base biasing is used, which is called voltage biasing. In the amplifier circuit shown below, with voltage bias, two resistors ( $R_1$  &  $R_2$ ) are used as a potential divider. A resistor  $R_3$  is also added in the emitter line to provide emitter feedback automatically to control the bias voltage under varying working conditions. This resistor is usually paralleled with a capacitor to provide further stabilization.

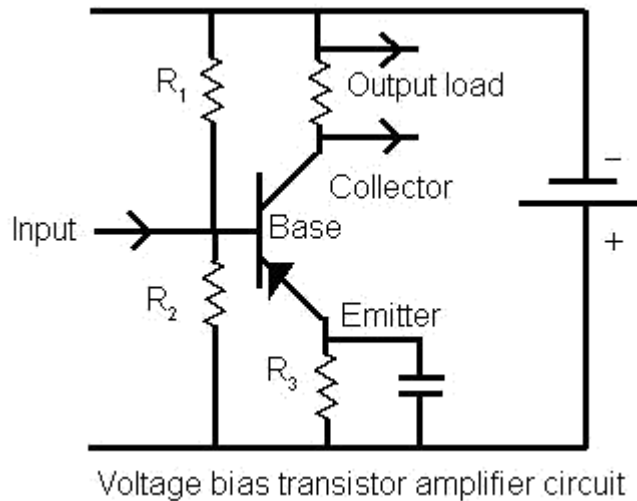

### D. Radio Receiver

A radio receiver is a device, which is used to receive **radio frequency transmission from a radio transmitter**. A radio transmitter transmits *radio frequency* (RF) signal generated at a particular frequency, on which the intelligence (e.g. any type of audio) is superimposed. Transmission of this audio information or *audio frequency* (AF) is possible only through the use of radio frequency. However, in reality the audio frequency (AF) does not get transmitted; instead, the sound content is literally carried on the back of the RF signal, the two together forming what is called a *modulated signal*.

Modulated radio frequency can be produced in two different ways--**amplitude** or 'up-and-down' modulation, known as AM; and **frequency modulation** (FM). In FM broadcast, actually a very small variation in the RF signal frequency takes place about the station frequency. FM technique is usually followed in very high frequency (VHF) transmissions.

$$\text{Wavelength (metres)} = \frac{300000000 \text{ metres}}{\text{Frequency (in Hertz, Hz)}}$$

$$\text{Or, Frequency (in Mega Hertz, MHz)} = \frac{300}{\text{Wavelength (in metres)}}$$

**Amplitude modulation technique is easier and hence widely used for medium wave and short wave broadcasts.** There are hundreds and thousands of broadcasts that take place in different radio frequencies or wavelengths. The relationship between wavelength and frequency is:

### Radio frequency (RF) generation

A basic oscillator which can produce oscillations at a particular frequency consists of a capacitor, a coil (inductor) and a DC voltage source along with a switch as shown below.

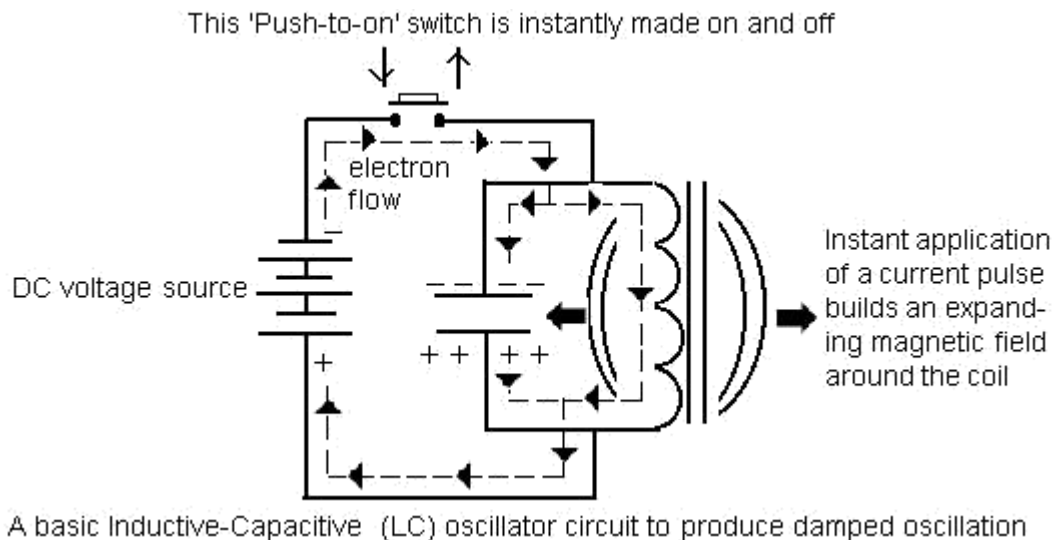

By making the switch 'ON' instantly and then releasing it to make 'OFF', a pulse of current finds its path to the capacitor as well through the inductor resulting in an expanding magnetic field across the inductor while charging the capacitor simultaneously. The instant when the switch is made 'OFF', the capacitor discharges releasing the extra electrons on the top plate through the inductor to reach the other plate. The current thus produced is in the same direction as when the switch was made 'ON'. Thus it aids in maintaining the expanding magnetic field produced during the instant when the switch was made 'ON'. The capacitor will reach a neutral state after the electron from the top plate neutralizes the bottom plate (the positively charged plate), i.e. the capacitor will be getting discharged in the process. As there is no supply of electrons from the DC voltage source (because the 'switch' is 'OFF'), and the capacitor is also fully discharged, so, the magnetic field around the inductor will now collapse resulting in a self-induced voltage. This self-induced voltage will make enough current to flow through the inductor to charge the capacitor in opposite direction. A similar process described above will now start and repeat over and over again producing damped oscillating currents until all of the energy is wasted by circuit resistance and other losses. This is called the '**flywheel effect**'. It is similar to what happens when a pendulum is started in motion. It tries to continue swinging at the same frequency until all of the starting energy is used up. The unique thing to notice here is that oscillations will maintain a particular frequency despite losing their amplitude. This frequency is called the resonant frequency and the circuit described above is called a tank circuit. The frequency of resonance can be found from the formula:

$$f_r = \frac{1}{2\pi\sqrt{LC}}$$

In the electronic circuitry, a damped oscillation is not at all desirable from the practical utility point of view. So, the objective is to use a transistor or triode valve to provide the necessary gain (and not loss!) and feedback (the energy) to sustain the oscillations or to produce perfect sine wave frequency. Described below are two practical oscillators.

## Hartley Oscillator

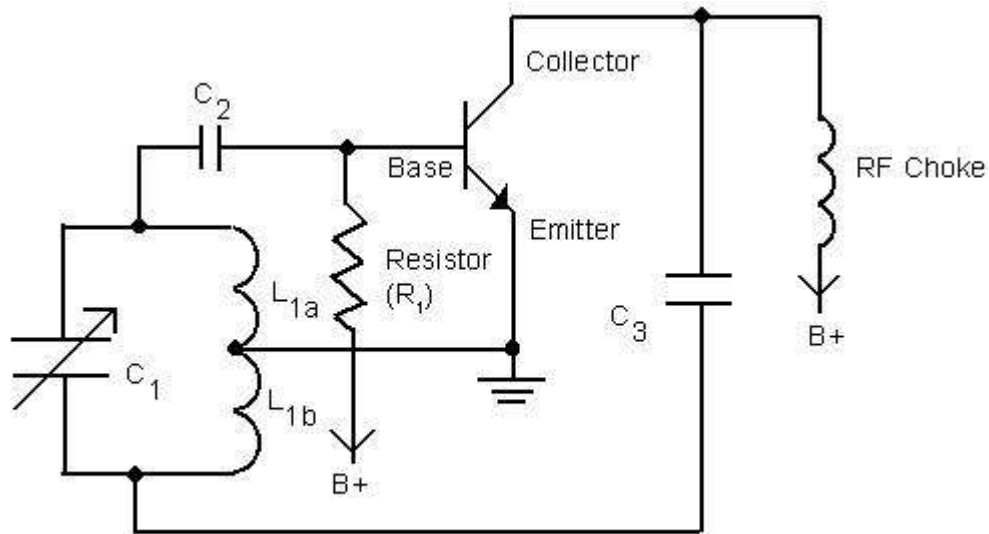

A Hartley oscillator circuit

In the Hartley oscillator circuit shown above, the frequency of oscillation is determined by the resonant frequency of the tank circuit consisting of  $C_1$  and  $L_1$ .  $L_1$  is tapped at its center to form two inductors :  $L_{1a}$  and  $L_{1b}$ .  $L_{1a}$  is effective in the base circuit of the PNP transistor and  $L_{1b}$  is in the collector circuit of the transistor. When  $B+$  is applied to the collector through a RF choke, collector current begins to flow. The resulting drop in collector voltage is coupled through  $C_3$  and developed across  $L_{1b}$ . This serves as the initial excitation for the tank and causes circulating current to begin to flow in the tank. The circulating current produces a voltage across  $L_{1a}$ , which is coupled by capacitor  $C_2$  to the base of the transistor. The amplified signal at the collector is coupled back to the tank circuit by capacitor  $C_3$ , and developed across  $L_{1b}$ . The feedback voltage developed across  $L_{1b}$  is in phase with the input voltage across  $L_{1a}$ , and so maintains the tank circuit oscillations.

## Colpitts oscillator

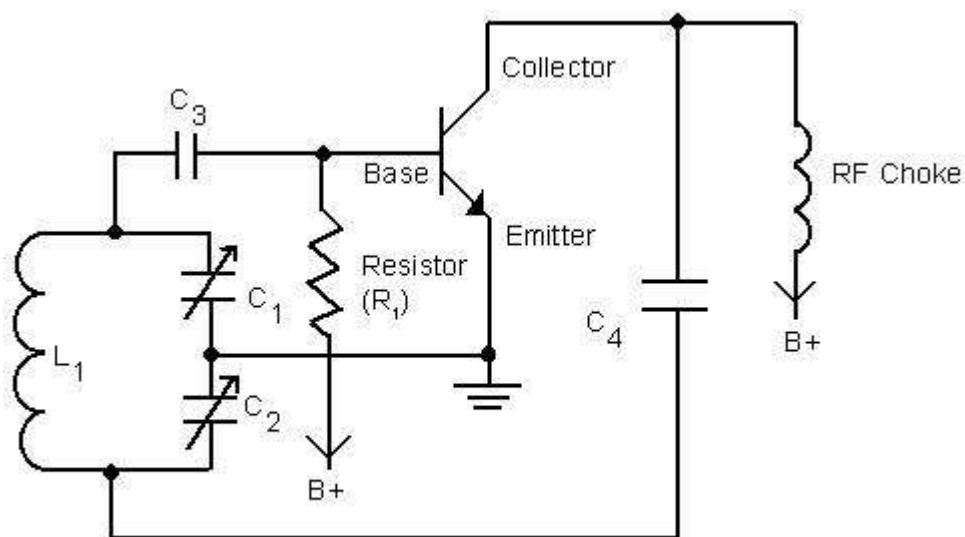

A Colpitts oscillator circuit

The Colpitts oscillator is similar to the Hartley oscillator, **except that two capacitors are used in the tank circuit instead of a tapped coil.** The output frequency of a Colpitts oscillator is determined by the value of the tank inductance and the total capacitance of the two series capacitors. Capacitor  $C_1$  is in the base circuit and  $C_2$  is in the collector circuit. The AC tank voltage produced by the circulating current divides between the two capacitors. The voltage across  $C_1$  is applied to the base of the transistor by coupling capacitor  $C_3$  and base resistor  $R_1$ . The resulting collector signal is coupled back to the tank circuit by capacitor  $C_4$  and developed across tank capacitor  $C_2$ . The feedback is in phase with the base voltage as a result of the 180-degree phase shift introduced by the transistor, and the 180-degree shift caused by the ground tap between  $C_1$  and  $C_2$ .

### Tuning circuit of radio receiver

The job of a radio receiver is to receive only a particular radio frequency at a single time. For this, a sorting device known as the '*tuning circuit*' (see page 76) is used at the '*front end*' of a radio receiver.

### Detection

After sorting out the desired frequency, a diode is used at the '**detector**' or '**demodulator**' stage of the receiver, where it rectifies out one half of the RF signal containing the audio information. This half cycle of the RF is still imposed with the AF content. So the next step is to filter out the RF to receive or detect an undulating AF signal. These undulations follow exactly the same variations as the AF signal originally imposed on the transmitter RF signal at the transmitting station by a microphone.

A resistor and a capacitor acts as a filter for a specified frequency. So, a diode detector is to match a load (resistor) with the capacitor so as to form the required filter circuit, so that only the varying dc (undulating AF portion of the signal) is passed at the output from the detector stage. A basic diode detector circuit is shown here.

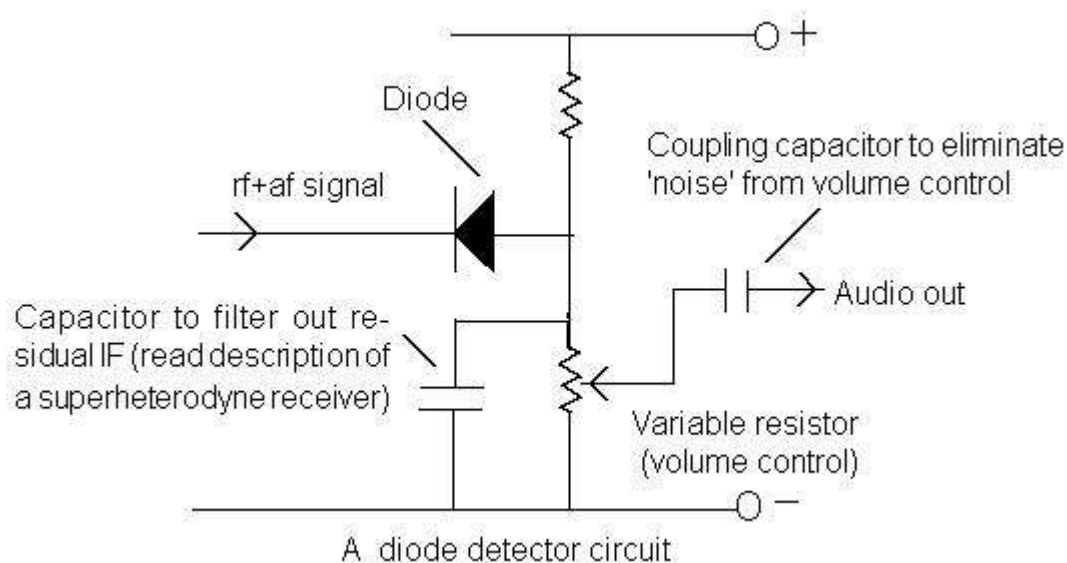

## AF Amplification

The audio signal thus obtained is then amplified in the audio amplifier stage of the receiver. There may be more than one stages of amplification but with the limitation of using only a certain number of stages of amplification after which distortion in the audio takes place.

**The radio receiver described above is a very simple radio receiver which has a limitation in its detector stage.** This type of receiver is called **Tuned Radio Frequency receiver (TRF)**. The detector works most effectively with an RF input voltage of 1 volt or more. Signal obtained directly from an aerial circuit are most of the time more than a few millivolts in strength, and weaker the signal the less effectively they will be detected. So, the range of stations that can be picked up is limited, and no amount of amplification after detection can make up for this limitation.

This limitation or lack of sensitivity can be overcome by amplifying the incoming signal before detection, so that the detector is always working with good signal strength. This is accomplished by the use of an amplifier stage right at the beginning of the circuit or by **super-heterodyne circuitry**. By **comparing and contrasting a ‘Tuned Radio Frequency (TRF) receiver’** with a **‘Super-heterodyne receiver’**, we can better understand the advantages as well as functioning of a super-heterodyne receiver.

## Difference between a Tuned Radio Frequency (TRF) receiver and a Super-heterodyne receiver.

A **TRF receiver** consists of the following stages:

- (i) Antenna input stage
- (ii) A few stages for RF-amplification
- (iii) A detector stage for demodulation
- (iv) One or more stages of AF amplifier

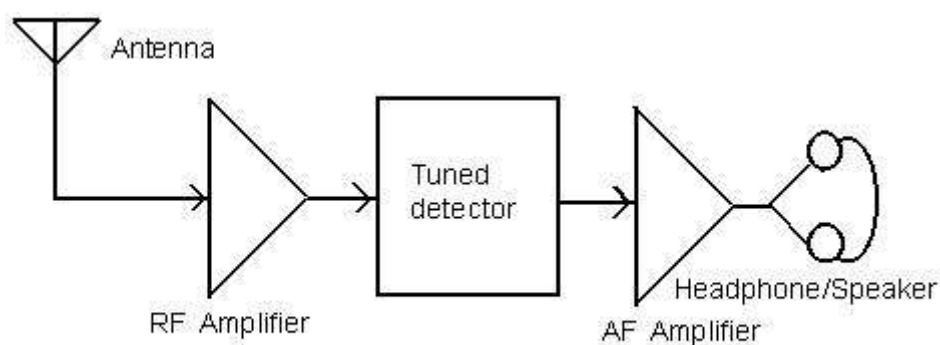

Block diagram of a simple Tuned Radio Frequency (TRF) Receiver

On the contrary, a **super-heterodyne receiver** consists of :

- (i) RF Amplifier
- (ii) Mixer or Converter
- (iii) Local Oscillator
- (iv) IF Amplifier

- (v) Detector
  - (vi) Automatic Gain Control (AGC) Circuit.
  - (vii) AF Amplifiers
1. In a TRF receiver a series of loosely coupled tuned circuits are used to increase selectivity and each circuit are ganged (interconnected) so that they resonate at the same frequency. But in a super-heterodyne receiver, this principle is not followed, instead, the RF amplifier, mixer and local oscillator are ganged to produce an intermediate frequency (IF).
  2. In a TRF receiver the high amplitude original frequency is demodulated at the detector stage. But in Super-heterodyne sets, the IF is demodulated.
  3. In a TRF Receiver, no image frequency is produced. But image frequency is produced in super-heterodyne receiver.
  4. In a TRF receiver, selectivity is not constant; the receiver is more selective at the low frequency bands, while less selective at the high frequency end. Because the detector and amplifiers of a super-heterodyne receiver can be designed to amplify only intermediate frequency (IF), this type of receiver is more selective and offer high fidelity (exact reproduction quality of the transmitted signal).
  5. In TRF receiver, amplification is not constant over the tuning range. In super-heterodyne receiver amplification is constant since all the time it amplifies a constant frequency at the IF stages.

### Functioning of a Super-heterodyne Receiver

The main objective of the super-heterodyne receiver is to produce an intermediate frequency (IF) by the process of heterodyning or beating. This can be accomplished when two frequencies are mixed to produce the beat frequency. In super-heterodyne receivers, the IF is usually **455 kHz which is selected because the broadcast band begins above that frequency**. So, if we imagine a situation when the RF amplifier is tuned to receive a 800 kHz broadcast signal, the local oscillator must be tuned to 1255 kHz, which will result in an IF of 455 kHz ( $1255-800 \text{ kHz}=455 \text{ kHz}$ ).

Since we have to tune the RF amplifier section throughout the entire broadcast band, the frequency of the local oscillator must also vary in a manner that it always maintains a gap of 455 kHz. To achieve this condition, the Local Oscillator and RF Amplifier section are '**ganged**', i.e. their tuning condensers are connected/ganged mechanically in such a way that when we tune the variable capacitor in the RF section, the variable capacitor in the local oscillator also changes its value, it 'tracks' the frequency to which the 'Aerial Circuit' is tuned and remain separated from the tuned frequency by 455 kHz up.

**The Intermediate Frequency (IF), which is a considerably low frequency is being used, because-**

- (i) it is a suitable frequency to achieve amplifying efficiency.
- (ii) It provides better selectivity.
- (iii) It provides better sensitivity throughout the broadcast band.
- (iv) It provides uniform sensitivity as well as uniform selectivity.

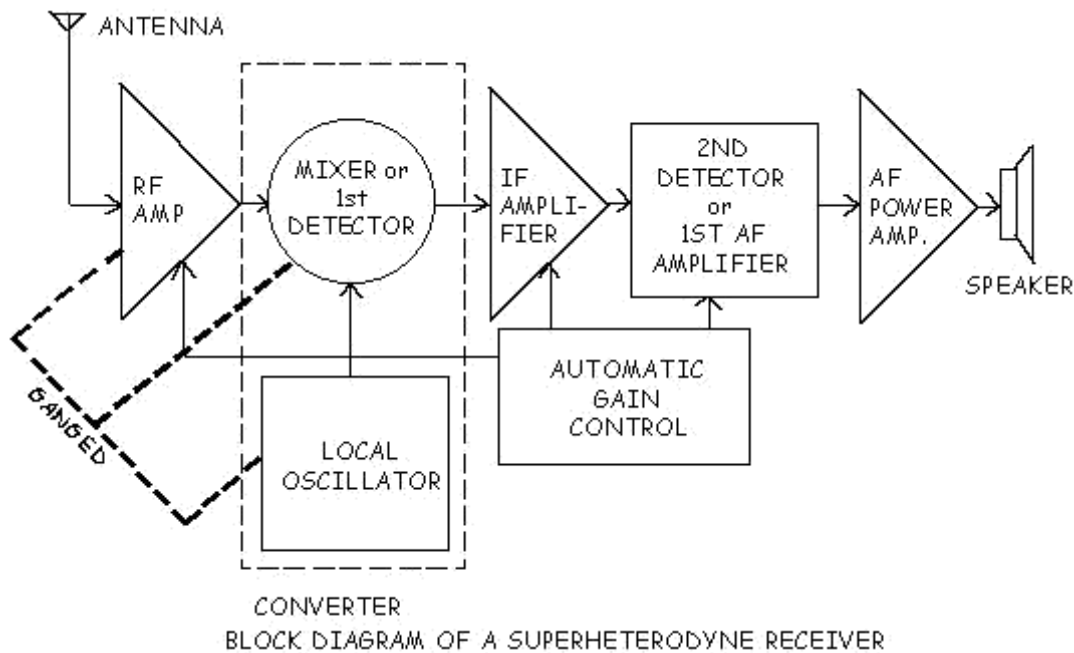

### Radio Frequency (RF) Amplifier section

This section performs two major tasks:

- (i) it couples the antenna voltage to the converter of the receiver;
- (ii) By selectivity, it accepts only the desired frequency and all others are rejected.
- (iii) By amplifying the desired signal, the Signal-to-Noise ratio is increased in the converter stage for efficient operation.

### Converter or Mixer Section

The main objective of the super-heterodyne receiver is to produce a constant Intermediate Frequency (most commonly used frequency being 455 kHz in commercial broadcast band radio sets). In the mixer stage, the local oscillator frequency and the selected station frequency is or combined, where, by the process of 'heterodyning', i.e. 'beating', the 'Intermediate Frequency (IF)' is obtained. If the RF Amplifier section selects and amplify a signal of 800 kHz, then the local oscillator produces a frequency of 1255 kHz. By mixing both the frequency at the mixer stage, a difference of frequency of the value 455 kHz is obtained ( $1255-800=455$  kHz).

### Intermediate Frequency (IF) Amplifier

The 455 kHz IF is fed to the IF amplifier through an IF transformer. The circuitry of the IF section is so designed and tuned so that it gives the optimum gain at that particular IF frequency.

### Detector/Demodulator and 1<sup>st</sup> Audio Frequency Amplifier stage

The Amplitude Modulated (AM) IF is demodulated and detected. A diode working as rectifier solves this purpose (see page 92). The triode/transistor amplifies the audio signal and the volume control potentiometer system controls the intensity of sound.

## AF Power Amplifier

This section further amplifies the audio signals which is finally fed to an output transformer which matches the impedance of output stage with the speaker (in modern transistor receivers, the necessity of output transformer is eliminated).

## AGC or AVC in a super-heterodyne radio set

Automatic Gain Control is a most needed part of super-heterodyne circuitry. A disadvantage of manual gain control (volume control) with a receiver is that it can't provide constant output under all conditions. If a receiver is tuned from a weak signal to strong signal, its output must increase intolerably. This would then require readjustment of the volume control. Similarly, when a receiver is tuned to particular signal the output level can vary widely if the input signal strength fluctuates as a result of fading and adjustments of the volume control has to be done. Since such signal fluctuations are rapid, constant readjustment of volume control would be necessary which is impractical. This is where AGC or AVC comes into picture and is used in addition to the manual control.

All AGC or AVC (Automatic Volume Control) circuits perform two basic functions;

- (i) The first of these is to develop a DC (Direct Current) which is proportional to the receiver input signal all the time.
- (ii) The AGC voltage is applied to the RF and IF stage of the receiver where it serves as a Bias voltage.

In this way the AGC voltage controls the gain of RF and IF stages, and therefore the overall gain of the receiver. When the signal level at the receiver input increases, the AGC voltage increases proportionately. Consequently, a larger bias is applied to the IF and RF stages and their gain is reduced.

The receiver output thus remains relatively constant instead of increasing in accordance with the input signal strength and vice-versa.

In valve type RX (receiver), the grids of RF and IF portions valves are biased by negative voltage. While in a transistor it depends on transistor type.

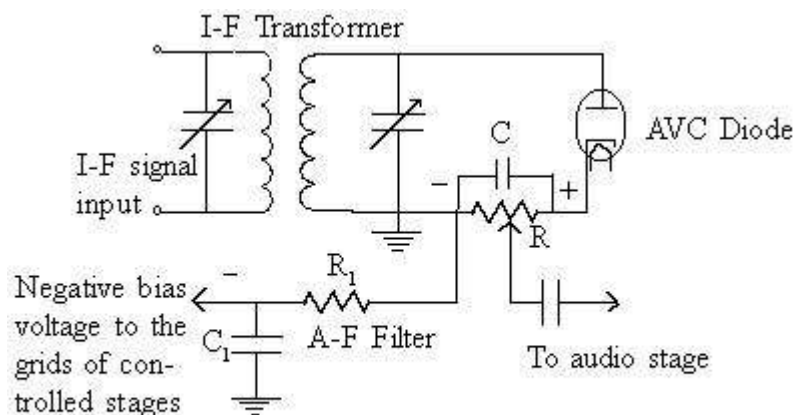

An Automatic Volume Control (AVC) Circuit

## Squelch circuit

The squelch circuit or Q (**Quieting**) circuit is a circuit which is controlled by AGC or AVC voltage. The modern high gain receivers shows a disadvantage without it, that is, without a squelch circuit, annoying buzzing and cracking sounds are heard over the loudspeaker in absence of input signal. So a circuitry is arranged in such a way that AF gain is kept reduced in absence of input signal from the antenna.

With no signal there is no Negative AGC voltage, and the squelch tube allows current to flow through it then passing through R3 to the +250 V point. Thus R3 produces a DC voltage drop across it which is more negative at midpoint than at the bottom being in series with the amplifier grid circuit, tube past cutoff, preventing it from functioning.

When a signal is received, AGC or AVC voltage biases the squelch tube to 'cutoff', stopping plate current flow. Consequently, the voltage drop across R3 ceases, allowing the AF amplifier tube to act in a normal manner.

## Image Frequency in a super-heterodyne receiver set

The intermediate stage (mixer + local oscillator) of a super-heterodyne radio set produces an Intermediate Frequency (IF) due to the beating of RF input frequency and Local Oscillator Frequency. This frequency is obtained by deducting the **RF input from the tuned circuit** from that of **Local Oscillator Frequency**. So, while receiving a 800 kHz RF signal, the Local Oscillator is made to oscillate at a frequency of 1255 kHz which results in an Intermediate Frequency (IF) of 455 kHz (which is accepted as a standard in almost all the Broadcast band receiver circuits); **but it is found that in case of comparatively less selective receiver, if a broadcast frequency 455 kHz up, from the 1255 kHz local oscillator frequency manages to intrude the RF tuned circuit even to a little extent, then another difference of frequency equal to intermediate frequency results; viz.  $1710-1255=455$  kHz. But this '455 kHz' being generated from a signal frequency having different audio information causes adverse effect at the audio end of the receiver.** The intelligence of both would be present in the speaker at the same time making the sound reproduction is unintelligible.

## Prevention of Image Frequency

- (i) By highly selective RF tuned amplifier;
- (ii) By using an IF which is convenient to use and at the same time separation between desired and image signals is made large. Possibility of image frequency generation is greater in a receiver designed for an IF of 175 kHz than a receiver using an IF of 455 kHz.

## 'Selectivity' of a radio receiver

Selectivity is the measure of the ability of a radio receiver to select a particular frequency or particular band of frequencies and rejecting all other unwanted frequencies. But higher selectivity does not necessarily make a better receiver. For instance, a 'broadcast signal' consists of the carrier frequency and its two side bands.

In a situation where a carrier frequency of 800 kHz is modulated with a 5 kHz (5000 Hz) tone, the sum of the carrier and the audio frequency results in the Upper Side Band (USB) of 805 kHz. The difference of carrier and audio frequency results in a Lower Side Band (LSB) of 795 kHz. So, for proper reproduction of the broadcast signal at a particular carrier frequency, the receiver must receive (select frequencies from 795 to 805 kHz). A receiver more selective than this would reject a part of the frequencies thus proper reproduction would be hindered.

### Sensitivity of a receiver

It is the ability of a radio receiver to respond to the desired radio frequency signal effectively. Higher the ability of the receiver to respond to a weak signal, greater is its sensitivity.

### What is a S-meter?

A S-meter is a visual indicator of signal strength. A simple S meter consists of a milliammeter in series with an RF or IF amplifier plate/collector circuit. With no signal, there is no AGC bias voltage and maximum plate current flows. With a signal, the AGC biases the tube, reducing the plate current and the indication on the meter. The stronger the signal, the lower the meter indication, signifying a strong strength.

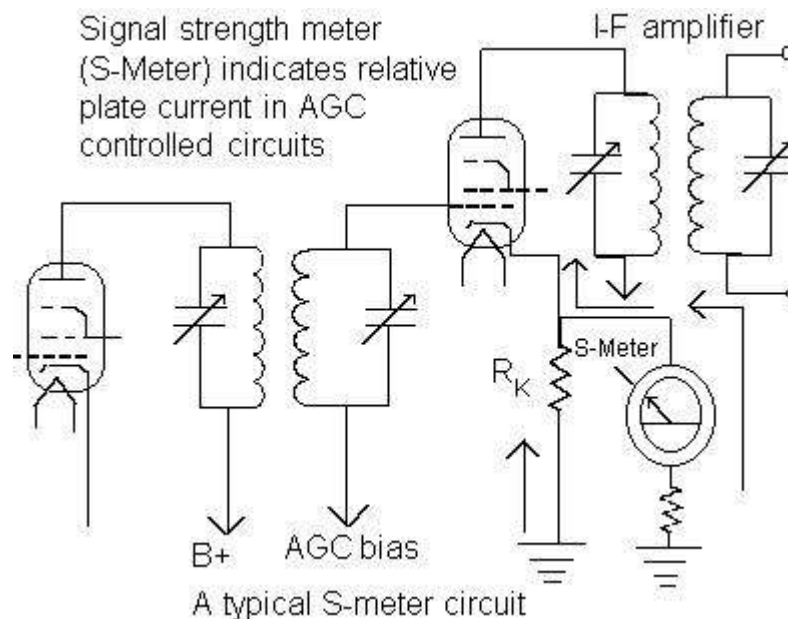

### What is a Beat Frequency Oscillator?

To change the second detector from a rectifying or envelope detector to a heterodyne detector to receive A1A (Continuous Wave Morse Code), A2A (Modulated CW Morse Code), J3E (Single Side Band), the Beat Frequency Oscillator is turned on. It is a variable frequency oscillator using a Hartley, Colpitts or Armstrong circuit. It is tunable to the Intermediate Frequency and one or two kilohertz higher and lower. It heterodynes with any signal coming through the IF strip, producing an audible beat frequency in the detector. Both the BFO and LO (Local Oscillator) must have good

frequency stability.

## **Why ham radio transmissions are not heard in ordinary radio receiver sets?**

The radio sets available in the market for general public are designed to receive Amplitude Modulated (AM) or Frequency Modulated (FM) broadcasts only. But the ham radio operators use a very efficient mode of transmission called Single Side Band (SSB) transmission. The power of a ham radio station is also very low ( usually not more than 100 watts) in comparison to the broadcast station (which use power in the kilowatts range). In fact many of the broadcast band radio receivers available in the market also covers some of the frequencies which are allotted to the ham radio stations. A 4 band radio set (inclusive of the Medium Wave band) can be expected to cover some popular ham radio frequencies like 7 to 7.1 MHz (i.e. 7000 to 7100 kHz), 14 to 14.350 MHz (i.e. 14,000 to 14,350 kHz) and 21 to 21.450 MHz (i.e. 21,000 to 21,450 kHz). This kind of receiver can be improvised to receive ham radio transmissions with very little effort.

First, we will need an outdoor aerial. Because, these radio sets are not sensitive to receive low power transmissions. Majority of the hams use power below 100 watts (a broadcast station may use 4000 or 5000 watts of power or even more than that!). A novice ham radio operator may be found to be operating with a power as low as 0.5 watt!

Ham radio conversation if heard on an ordinary radio set sounds like the 'Duck quacking'. There is no intelligibility in the audio. As already mentioned, our ordinary radio sets are meant to receive AM signals only and not to receive SSB signals-a separate unit is required at the '**Detector**' stage of the AM receiver, which is nothing but a stable '**Frequency Generator**' (RF Oscillator), called the '**Beat Frequency Oscillator**' (**BFO**). The BFO is used to introduce a '**Local Carrier Frequency**' (frequency of the carrier is 10 to 20 Hertz within that of the transmitter carrier frequency which is suppressed at the transmitter of the ham radio station willingly in order to save power). A BFO can also be used to make the un-modulated Continuous Carrier Wave (CW) transmissions (e.g. in Morse Code transmission) intelligible.

## **E. Radio Transmitters**

### **Amplitude Modulation and %ge of modulation**

Amplitude Modulation (AM) is a process in which the amplitude of a radio frequency current is made to vary and modify by impressing an audio frequency current on it.

A radio frequency current has a constant amplitude in absence of modulation and this constant amplitude RF carries no information, i.e. no audio intelligence and is of no use to radio telephone (voice communication), but has application in morse code communication.

So, to give intelligence to the RF current, audio signal is impressed/superimposed on the RF current in a non -linear modulator circuit; as a result of which carrier current amplitude begins to rise to a maximum value above and below its original amplitude during the positive cycle of the audio signal and during

the negative cycle of the audio signal, it falls to a minimum value.

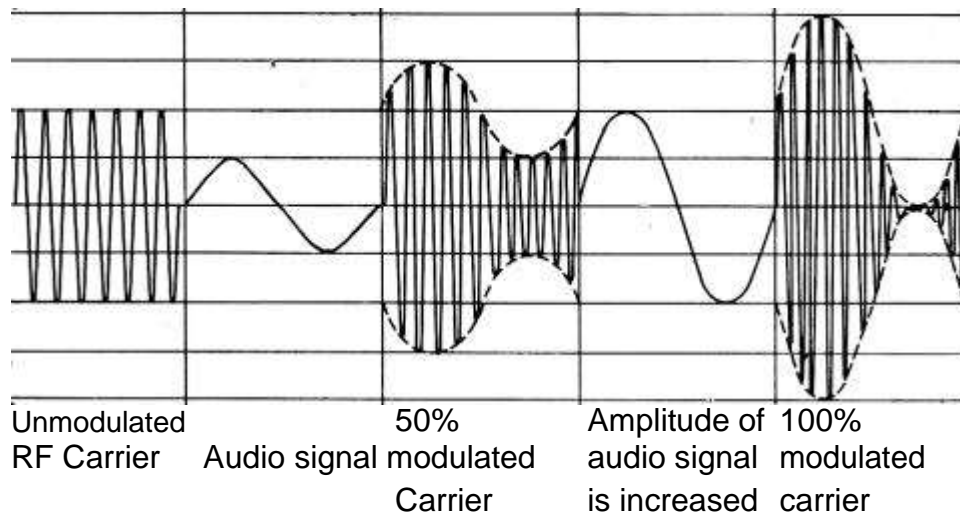

This results in the carrier having two outlines of the audio signal, this is because the variation at instant in the amplitude of the carrier wave is directly proportional to the value of the modulating signal.

During amplitude modulation, two side band frequencies are also produced. Upper sideband frequencies equal to the carrier frequency plus audio frequency and lower side band frequency is equal to carrier frequency minus audio frequency. So the amplitude modulated carrier occupies a space in frequency spectrum, the width of which is equal to twice the highest modulating frequency.

### Percentage of modulation

The degree of modulation in an AM wave is expressed by %ge of maximum deviation from the normal amplitude of the carrier RF wave.

The effect of such modulated wave is measured by a receiver's ability to reproduce the signal in distorted or undistorted manner.

$$\text{Percentage of modulation} = \frac{\text{Voltage}_{\text{Max}} - \text{Voltage}_{\text{Min}}}{\text{Voltage}_{\text{Max}} + \text{Voltage}_{\text{Min}}} \times 100$$

Where  $\text{Voltage}_{\text{Max}}$  is the maximum instantaneous value of the modulation and  $\text{Voltage}_{\text{Min}}$  is the minimum value of the RF carrier.

### Why over modulation is not desirable?

Over modulation is not desirable, i.e. modulation should not exceed 100 %, because if modulation exceeds 100 % there is an interval during the audio cycle when the RF carrier is removed completely from the air thus producing distortion in the

transmission.

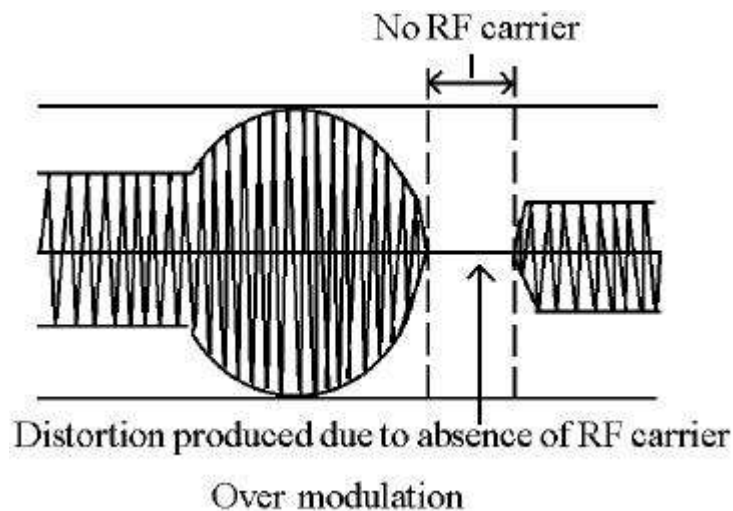

### What are the Side-bands of an AM signal?

Side bands are the sum and difference frequencies produced at the transmitter by the modulating frequencies. For instance a 5 kHz (5,000 Hz) Audio tone might be used to modulate an 800 kHz carrier frequency. This would produce frequencies of 800 kHz, 805 kHz and 795 kHz. 800 kHz is the carrier and 795 and 805 kHz are the two side band frequencies.

### What is Single Side Band (SSB) transmission?

At full modulation the carrier in an AM signal requires two thirds of the power but conveys no information. The second side band can be viewed as redundant (overlooking frequency-selective fading in an ionospheric transmission path, that may distort one side band at times). Interference between several carrier frequencies, resulting in steady audio whistles or 'beats' is another disadvantage of AM.

Power may be saved and the band occupied by an AM signal in the frequency spectrum can be halved if only one side band is transmitted without carrier. The result is single side band suppressed carrier signal, called simply single side band signal (SSB) transmission.

The carrier must be reintroduced at the receiver in such systems and closely adjusted to the original carrier frequency to avoid signal distortion. The introduced carrier must be within 10 or 20 Hertz of the original carrier frequency for adequate intelligibility of voice signals, and stable oscillators are needed for generation of the local carrier.

For SSB the transmitter does not need to generate carrier power, and ratings are in terms of peak-envelope-power (PEP), the power capability at the peak of the modulating signal with linearity of the amplifier is maintained. For equal information content, and 100% modulation, the SSB signal requires only  $\frac{1}{6}$  th power of the double side band signal. However, the situation is even more favourable to SSB when speech is transmitted. Speech is not a continuous sine wave, and its average power is low with respect to its peak requirements. A peak-to-average power ratio of 10:1 is often assumed for speech, and under that condition, a Double Side Band (DSB) AM signal would require 1.05 times carrier power, whereas for equal intelligibility the

SSB signal would require only 0.05 units of power or  $\frac{1}{21}$  as much.

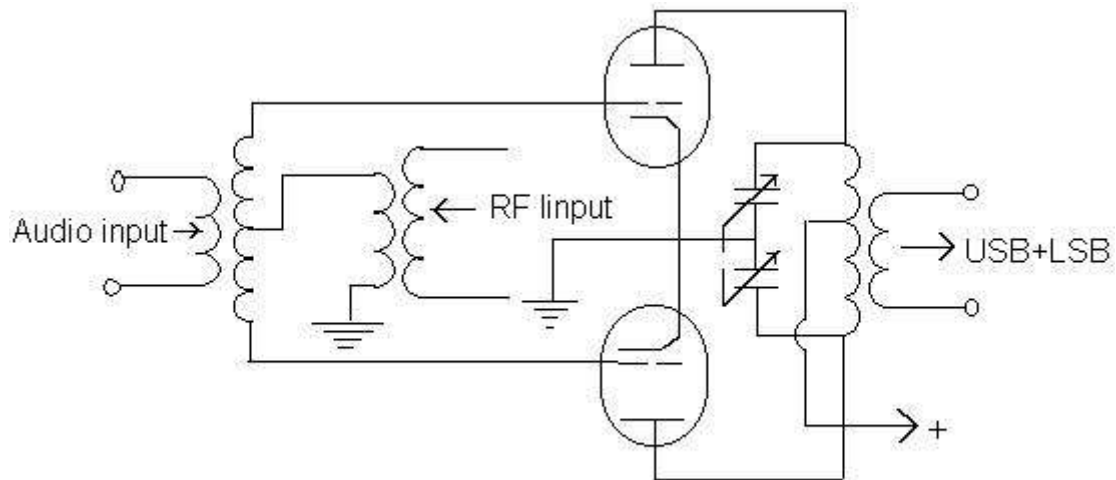

A balanced modulator circuit using valve

Because of the lower power rating, circuit components designed for SSB equipment can be smaller and lower in cost.

For generation of a modulated signal without carrier, a **balanced modulator** is used. A filter then discards one side band.

### Why 100% modulation should be aimed in voice transmission?

The power of a modulated wave is found from the formula:

$$P_{\text{mod}} = (1 + m^2/2) \times P_{\text{carr}}$$

Where  $P_{\text{mod}}$  = Power of the modulated wave,

$M$  = degree of modulation,

$P_{\text{carr}}$  = power in the carrier frequency.

The power in an amplitude modulated wave is divided between the carrier and the two side bands. The carrier power is constant, and so, the side band power is the difference between the carrier power and the total power in the modulated wave. The above formula is to find the power of the modulated wave when carrier is modulated by single sinusoidal tone.

If the carrier power = 50 watts

% of modulation = 100 or 1

degree of modulation = 1

Then the power of the modulated wave,

$$P_{\text{mod}} = (1 + m^2/2) \times 50 = \frac{3}{2} \times 50 = 75 \text{ watts}$$

Since the carrier power = 50 watts; the two side bands have 25 watts in them, i.e.

$\frac{25}{75} \times 100\% = 33.3\%$  of the total power with 100% modulation.

In case of 50% modulation with same carrier power we have,

$$P_{\text{mod}} = (1 + 0.5^2/2) \times 50 = 2.25/2 \times 50 = 56.25 \text{ watts}$$

Now the side bands have only 6.25 watts (since  $56.25 - 50 = 6.25$ )

Since all the intelligence being transmitted is contained in the side bands, the desirability of a high percentage of modulation is crystal clear. A comparatively low powered, but well modulated transmitter often produces a stronger signal at a given point than does a much higher powered, but poorly modulated, transmitted the same distance from the receiver.

### Schematic diagram of our intended transmitter and its function in brief

#### RF Oscillator

This is the stage where the carrier frequency intended to be used is generated by means of Crystal Oscillator Circuitry or capacitance-inductance based Variable Frequency Oscillator (VFO). The RF oscillator is designed to have frequency stability and power delivered from it is of little importance, hence can be operated with low voltage power supply with little dissipation of heat.

#### Buffer Amplifier

The low power RF carrier output from the RF oscillator is amplified in this portion and it also keeps the RF oscillator and power amplifier circuits separate electrically imparting frequency as desired by the amateur can be done in this stage, when the carrier frequency multiplication technique is applied here. In it the Morse key for keying out carrier continuous wave can be accommodated.

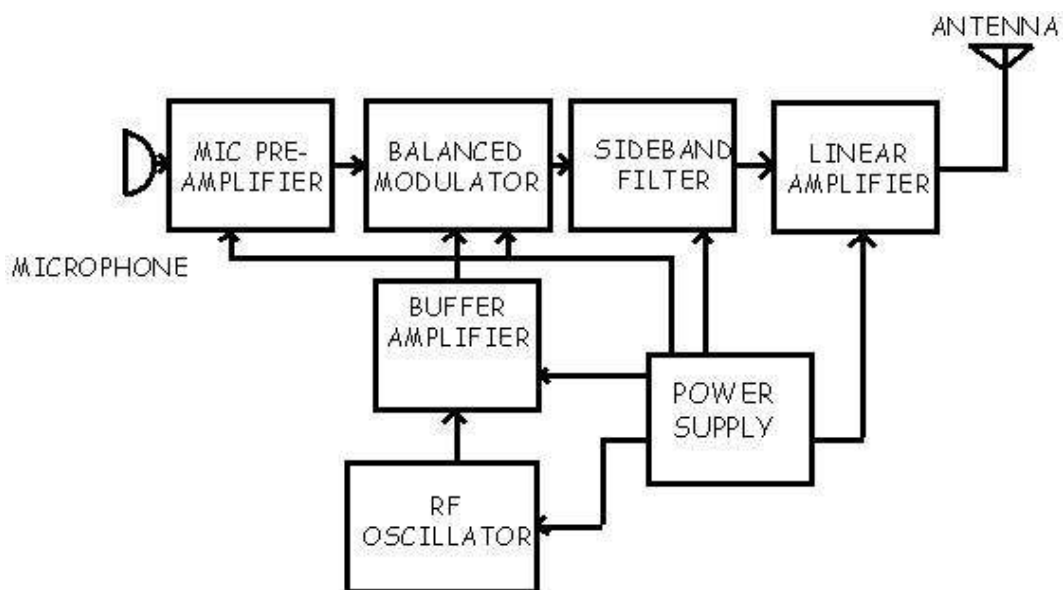

#### Modulator

Audio information is impressed upon the carrier frequency at this stage.

### **Balanced Modulator**

In this type of modulator, while the audio information (voice) is impressed upon the carrier frequency, at the same time its output gives a signal without carrier frequency but yet with the two side band frequencies carrying the voice/audio information.

### **Side-band filter**

It discards out any one of the side band.

### **RF linear Amplifier**

RF power amplification is done here and this stage is coupled to the antenna system through antenna impedance matching circuitry. Care is taken at this stage so that no harmonic frequency is generated which will cause interference in adjacent band (splatter) on other bands.

## **Crystal oscillators**

Crystal oscillators are used in most modern commercial radio transmitters, either telegraph or telephone. Quartz crystal oscillators are used because they do not drift more than a few hertz from the frequency for which they are ground. A variable Frequency Oscillator (VFO) tends to drift considerably more.

Crystals made from quartz are used in radio frequency oscillator circuits in order to impart stability to the frequency of oscillation. The function of the quartz crystals are based on the piezoelectric effect, i.e. generation of electricity by compressing or stretching the quartz. Conversely the quartz crystal can be made to expand or contract physically by applying a voltage across it (e.g. by placing it between two metallic plates where the voltage is applied).

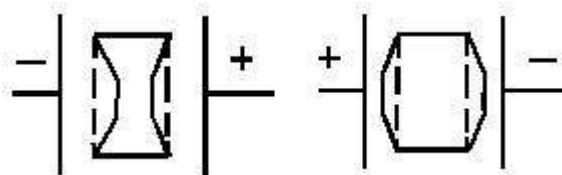

Expansion and contraction of a crystal

At its resonant frequency a crystal behaves exactly like a tuned circuit. If a crystal between metal plates is shock-excited by either a physical stress or an electric charge, it will vibrate mechanically at its natural frequency for a short while and at the same time produce an ac emf between the plates. This is somewhat similar to the damped electron oscillation of a shock excited LC circuit.

The circuit shown in the next page is a TPTG (Tuned Plate Tuned Grid) circuit. When the switch is closed, the LC (Inductance -Capacitance) tank in the plate circuit is shock-excited into oscillation by the sudden surge of plate current. The ac developed across this LC circuit is fed back to the top crystal plate through inter-electrode capacitance, and to the bottom plate of the crystal through the bypass

capacitor from the LC circuit. The crystal starts vibrating and working as an ac generator on its own. The emf generated by the crystal, applied to the grid and cathode, produces plate current ( $I_p$ ) variations in the plate LC circuit.

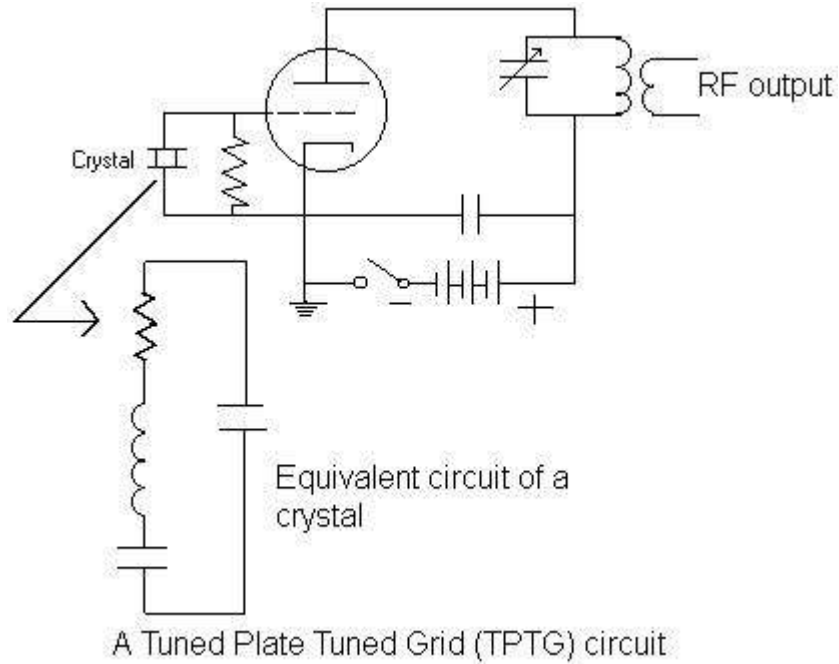

With both crystal and LC circuit oscillating and feeding each other in proper phase, the whole circuit oscillates as a very stable ac source. The plate LC circuit must be tuned slightly higher in frequency than the crystal to produce the required phase relationship between the two circuits to sustain oscillations.

## F. Radio Wave Propagation

## The Role of Ionosphere in Radio Wave Propagation

Long distance propagation of radio waves depends on an invisible layer of charged particles, which envelops the Earth. This layer of charged particles known as the ionosphere has been in existence for millions of years. For those, who pioneered the long distance radio communication during the early part of the twentieth century, the ionosphere came as a boon. During the formative days of radio communication, radio scientists could not come to a definite conclusion about how radio waves propagated round the world. The father of radio, Guglielmo Marconi himself was at a loss to explain how, on 12th December, 1901, he established the first real long distance wireless communication between St. Johns, New Foundland, USA (now in Canada) and Poldhu in the Southern Tip of England, a distance of more than 3,000 kms across the Atlantic Ocean. At that time, it was known that except for very short distances, the radio waves did not follow the natural curvature of the earth. Earth's curvature is a direct block to line-of-sight communication. When enough distance separates the **two** radio stations so that their antennas fall behind the curvature, the Earth itself blocks the transmitted signals from the receiver, because, electromagnetic waves travel in straight lines until they are deflected by something.

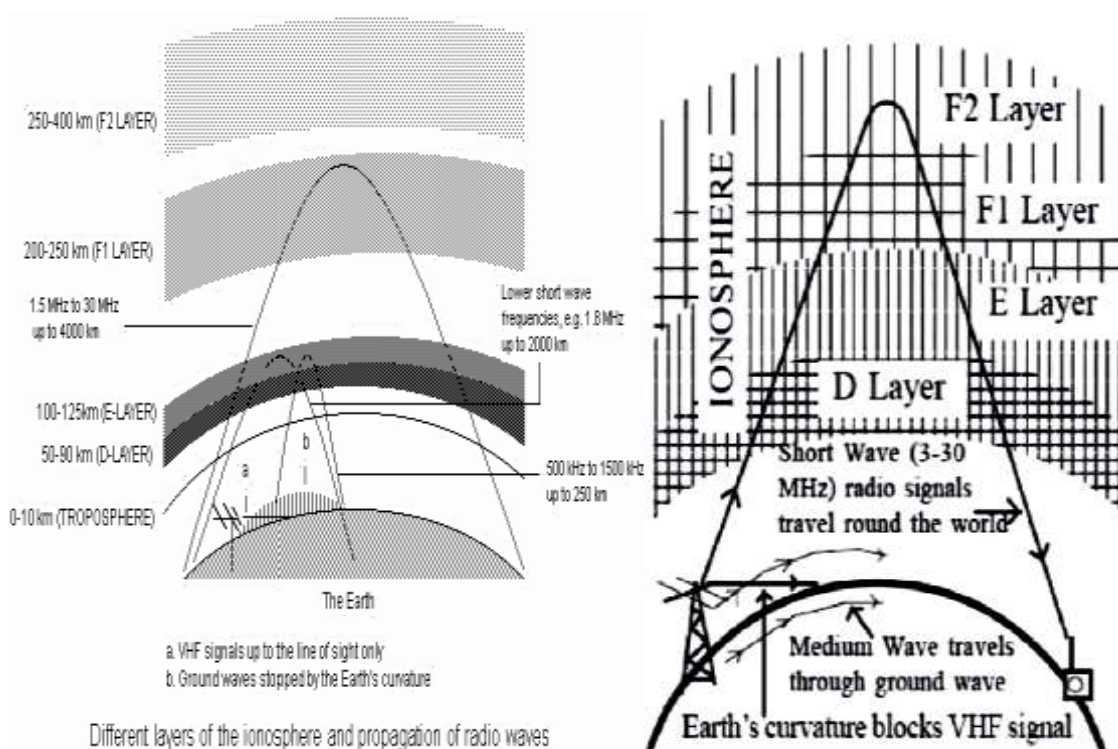

**Oliver Heaviside** in England and **A.E. Kennally** in America, in 1902, suggested that there must be some kind of reflecting medium in the upper atmosphere that caused the radio waves to be returned to Earth at considerable distances from the transmitter. Under the action of solar radiation and the hail of meteorites, an ionised layer is formed in the upper part of the Earth's atmosphere. In this layer, the neutral air molecules are decomposed into ions and electrons and the whole layer presents a chaos of charged particles. Short wave radio signals (radio signals which fall in the range of 1.5 MHz to 30 MHz) are reflected from this layer just as light rays are reflected from the surface of a mirror, or sound wave from a barrier. likewise, this

layer can be compared to the edge of a billiard table. Communication specialists use this layer like the edge of a billiard table: if the ball does not go straight into the pocket, it can be directed on the rebound! In the same way, the short wave signals radiated by distant radio stations get to our receiver on the rebound. They can continue traveling to several places round the world, for the Earth is also like the edge of a billiard-table.

The ionosphere is located above the troposphere, starting at an altitude of 50 kms above the surface of the earth and extending up to an altitude of 400 kms or more. The troposphere is the region of the earth's atmosphere immediately adjacent to the earth's surface and extending upward for some tens of kilometres. Radio waves are refracted or bent slightly, when traveling from one medium to another. **Refraction is caused by a change in the velocity of a wave when it crosses the boundary between one propagating medium and another.** If this transition is made at an angle, one portion of the wave-front slows down or speeds up before the other, thus bending the wave slightly. Radio waves are commonly refracted when they travel through different layers of the atmosphere, whether it is highly charged ionospheric layers 100 km and higher, or weather-sensitive area near the Earth surface. When the ratio of the refractive indices of two media is great enough, radio waves can be reflected, just like light waves striking a mirror.

The role of ionosphere in radio wave propagation can be discussed only in terms of the different radio frequencies available for communication and in the light of the existence of different ionospheric layers. Although the various methods used confirmed the theories of Heaviside and Kennally, there were differences between the results obtained by Professor Appleton and other investigators. It was discovered that there was not one, but more than one reflecting layers in the ionosphere. **The first trials with pulse waves in 1925 by Breit and Tuve in America** were successful in that the method proved to be much more practicable. Since **radio waves take 1 millisecond to travel 300 km**, the height of the layer established from the first echo in this case was found to be 300 km. The ionised layers were designated with letters of the alphabet by E. V. Appleton.

The lowest layer known at a height of about **50 to 90 km** being called the **D region** because this is not strictly a layer **but a relatively dense part of the atmosphere where atoms are broken up into ions by sunlight that recombine very quickly.** The amount of ionisation therefore depends on the amount of sunlight and the region has the effect of absorbing the energy from a radio wave, particularly at frequencies in the band of 3 to 4 MHz and frequently as high as 7 MHz. **High frequencies** (1.5- 30 MHz) penetrate this layer, while low frequency (LF: 30-300 kHz) and medium waves are absorbed by this layer. To some extent LF and Very Low Frequency (VLF: 3 to 30 kHz) are reflected during daytime.

The **E-layer** extends from an altitude of 100 km. Though sunlight is an important factor for its existence, after sunset also it exists for some time. This layer is responsible for evening and early night time propagation of medium waves (500 kHz to 1500 kHz) up to a distance of about 250 km. Propagation of lower short wave frequencies, e.g. 2 MHz, up to distance of 2000 km at daylight time is due to this layer. It has little effect at night.

**F<sub>1</sub>** layer exists at an altitude of 200 km during daytime and its characteristics are very similar to E-layer which merges into F<sub>2</sub> layer at night. HF frequencies in the

range of 1500 kHz to 30 MHz (i.e. 30,000 kHz) propagates through this layer during daytime.

**F<sub>2</sub> layer** is the most important layer, which exists at altitudes ranging from 250 to 400 km and HF long distance propagation round the clock is due to this layer. The behaviour of this layer is influenced by the time of the day, by season and by sunspot activity. **F<sub>2</sub> layer was formerly known as Appleton layer.** This layer has a high ionization gradient. This layer exists both in the daytime and nighttime. Since at such an altitude air density is extremely low, the free ions and electrons (due to the action of ultraviolet radiation from the Sun) cannot recombine readily and so can store energy received from the Sun for many hours; that is the reason **the refractive property of this layer changes only to a negligible extent during day and night.** The path which the short wave signal follows through the F<sub>2</sub> layer is in reality a curved one. Degree of the curve depends on the angle of incidence of the wave, ionization gradient of the layer and frequency of the signal. Maximum distance for F<sub>2</sub> layer reflection is about 4000 km.

### **Radio wave propagation by multiple reflection**

A strong enough radio signal can propagate by multiple reflections. Having returned to Earth from the ionosphere, the Earth's surface acts as a reflector and returns the signal back to the ionosphere, where it is reflected back to Earth yet again. In this way radio signals can travel around the globe almost instantly! Because, radio wave travels at a velocity of 3,00000 km per second in vacuum. Its velocity gets changed very negligibly in a different medium, which is insignificant, because the earth is a very small place with a radius of only 6000-km. Communication between any two points on the earth is thus almost instantaneous.

### **Propagation characteristics of different ham radio bands**

The problem of variable propagation conditions can be partially overcome by using frequency diversity, in which an allotted wireless communication network is provided with several frequency assignments spanning the high frequency (short wave) band of frequencies. The radio operator can thus choose the channel that gives the best results at any given time. The 1800 kHz (1.8 MHz or 160 metre band) band suffers from extreme daytime D-layer absorption. Even at high radiation angles, virtually no signal can pass through the F layer and daytime communication is limited to ground-wave coverage. **At night, the D layer quickly disappears and world-wide 160m communication becomes possible via F<sub>2</sub>-layer skip. Atmospheric and man-made noise limit propagation of this band. Tropical and mid-latitude thunderstorms cause high levels of static in summer, making winter evenings the best time to work long distance at 1.8 MHz.**

The **3500 kHz** (3.5 MHz or 80 metre band) is the lowest HF ham band, which is similar to 160 m in many respects. Daytime absorption is significant, but not quite as extreme as at 1.8 MHz. High-angle signals may penetrate to the E and F layers.

**Daytime communication range is typically limited to 400 km, primarily via ground-wave propagation.** At night, signals are often propagated halfway around the world. As at 1.8 MHz, atmospheric noise is a nuisance, making winter the most attractive season for the 80 m. The **7000 kHz** (7 MHz or 40 metre) band is useful for

daytime communication up to a distance of **800 km** via **E and F layers**. Long distance world-wide communication takes place in this band through F2 layer. The **10 MHz** or 30 metre band is unique because it shares characteristics of both daytime and night-time bands. Communication up to **3000 km is typical during daytime**, and this extends halfway around the world. The band is generally open via F2 on a 24-hour basis. Unfortunately, the 10 MHz band is not yet released to the Indian ham radio operators.

### **Skip distance, skip zone and dead zone**

**Skip distance, skip zone and dead zone** are importantly associated with ionospheric propagation. If we take a simple case, where a radio receiver located at a distance of 200 kilometres away from the wireless transmitting station is unable to receive the radio signal, but another receiving station (the **intended station**) at a greater distance (say 1000 km) is able to receive the radio signal perfectly, **then distance of the intended receiver from the transmitter is termed as 'skip distance'**.

Despite being located closer to the radio transmitter, one of the receiving stations is not able to receive the radio signal. This is because of the fact that this receiving station is located in a **skip zone or dead zone**. **The ground waves transmitted from the transmitter are unable to reach this receiving station because of signal attenuation by the earth or are stopped by the Earth's curvature and the sky wave will not reach the receiver, because it bounces again more than 200 kilometers way**. So some **'blind zones'** are formed and if the receiver is located in that blind zone it will receive no signal or very weak signal.

The above situations are particularly pronounced in high frequency (HF) signals where ground waves fade away and skip distances may be a thousand kilometers or more. In such a situation, another station (who is not in skip with the station in blind zone) can relay the message to the receiving station located in the blind zone.

### **How do the hams overcome the variable propagation conditions of the ionosphere and the problem of skip?**

The problem of variable propagation conditions can be partially overcome by using frequency diversity, in which an allotted communication network is provided with several frequency assignments spanning the High Frequency (HF) band of frequencies. The ham can choose the frequency that gives the best results at any given time. Similarly if a station is in skip at a particular frequency, another workable frequency can be found out.

### **What is line-of-sight propagation?**

The radio frequencies above 30 MHz has the tendency to penetrate the ionosphere making them unsuitable for long distance propagation. So, the range of frequencies from **30 to 300 MHz** (also 300 MHz and above), which are placed under the **Very High Frequency (VHF)** category are mainly used for line -of -sight communication. The most common example of line-of -sight communication is the TV Telecast. Ham radio operators use VHF frequencies in the range of 144-148 MHz (as well as 50 MHz in some countries) for line of sight communication.

A TV transmission tower is made as tall as possible so that its signals can have a wide area of coverage. To receive a TV telecast, we have to turn our TV antenna (known as a Yagi antenna) towards the TV transmission tower. In areas where the TV transmission tower is located at a far away place from a viewer, the viewer has to increase the height of his TV receiving antenna. This means that both the transmitting and receiving antenna should literally see each other to make the communication effective. Otherwise there should be some means to redirect the signal back to the receiver. Artificial Satellites in space (which houses active electronic relaying device), terrestrial relay station and passive reflectors (the metallic plates we see above the hills) are employed to extend the VHF coverage. Line-of-sight communication is considered reliable within a short distance (or even for long distance communication if artificial communication satellites are employed), because instead of relying on the ionosphere (whose propagation conditions are not under human control), relay stations (known as repeater station) can be set up on tall towers. The relay station can cover a certain area most reliably round the clock. Different services employing VHF for communication also have their own repeater station.

Another advantage of VHF is that the size of the VHF equipment is very small (because of its low power as well as miniaturization in the circuit design). A VHF communication set is also popularly known as a Walkie-Talkie. We are certain that the above description is sufficient to clear any doubt about the range of a Walkie-Talkie !

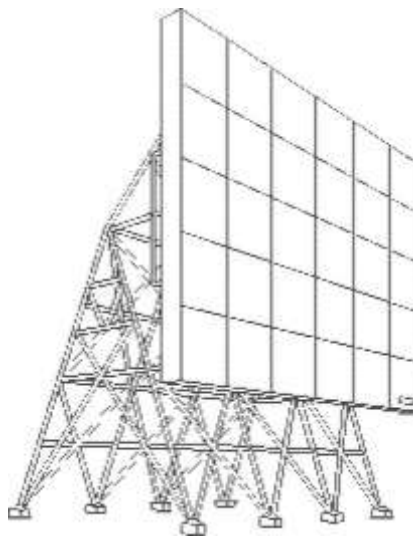

A Passive reflector

### **What are the two phenomenae significant in line-of-sight reception?**

In case of line -of- sight reception, sometimes there may be **two components** of the signal. One is the **direct signal** and other may be **the signal reflected from the ionosphere** (e.g. in case of a 50 MHz signal, which rarely gets reflected by the ionosphere). Both the signals leave the antenna with the same signal phase, but travel different paths to the receiving antenna. These paths may be of different length. Because the reflected signal **suffers 180 degree phase reversal** at the point of reflection, the two signals may **aid or oppose** each other in the receiving antenna. The

resultant signal may be stronger or weaker than the direct path signal alone, which is not desirable.

**The problem arising out of the undesirable phase reversal phenomenon can be overcome by varying the height of the antenna.**

### **What is the temperature inversion phenomenon as applicable to the line-of-sight communication?**

The line-of-sight propagation is limited to the optical horizon and it is only about 75 km for frequencies above 30 MHz; but it is found that in the spring, or sometimes in summer, this line-of-sight propagation extends to about 500 kms. This is due to the presence of layer of hot, dry air above a layer of cool, moist air. The direct waves are bent back which otherwise pass over the receiving antenna.

### **What is 'Grey line' propagation as applicable to line-of-sight communication?**

It has been observed that around sunspot maximum years at about 11-years intervals, the daytime F<sub>2</sub> layer, roughly 250-400 kms above the surface of the Earth, can often open long distance paths of frequencies up to and beyond **50 MHz**. In periods of low sunspot activity very few long-distance paths are open above 25 MHz. Radio amateurs, whose transmitters are so much less powerful than those used for broadcasting, have come to recognise the importance of what is called '**grey line**' propagation. This takes the form of reliable but brief long-distance paths that open between places where the times of dawn and dusk, dawn and dawn or dusk and dusk roughly coincide, giving rise to the possibility of extended 'one-hop' propagation due to layer entrapment brought about by tilts in the F-layer, as the lower F<sub>1</sub> and higher F<sub>2</sub> layers combine or separate.

### **What is a critical frequency?**

The whole spectrum of radio frequencies suffer various degrees of refraction by the ionosphere. Waves which are very slightly refracted can not return back to the Earth and if not having adequate power, get absorbed into the ionosphere. Those having sufficient power can penetrate the ionosphere depending upon the degree of refraction. **The amount of refraction is inversely proportional to the frequency of the wave.** Obviously, **lower the frequency, greater is the refraction and higher the frequency, lower is the refraction.** Though a greater refraction should cause the frequency to be returned back to Earth, it does not happen always. During day time, the D layer (It is the lowest region of the ionosphere at a height of about 50 to 90 km. It is not strictly a layer but a relatively dense part of the atmosphere where atoms are broken up into ions by sunlight that recombine very quickly) absorbs most of these waves prohibiting their entry into the E and F layers and hence does not get reflected.

**If the frequency of a wave transmitted directly upward is steadily increased, a point would be reached where the wave would pass right through the ionosphere. The frequency at which this occurs is called the *critical frequency*.** All frequencies higher than this will not be returned to Earth.

## **What is a beacon?**

The beacon is nothing but a radio signal, usually in coded form transmitted from a particular station to identify itself. The usefulness of the beacons is that they provide indication of propagation conditions between any two locations worldwide. They also act as in-band frequency reference for wireless experiments experimenting with transmitters. They also provide reliable checking facility for beam antennae.

## **What are differences between fade-out and fading?**

### **Fade-out**

It is the gradual phenomenon, that take place with the change of time of the day. Fadeout of radio signal is related to the ionization gradient of the ionosphere, which decreases in absence of sunlight. Since ionization is intense during day light hours, higher frequencies of the short wave spectrum can be used during daylight hours. As the night approaches, signal strength at that higher frequency decreases. Using a frequency at the lower edge of the HF spectrum will yield satisfactory result against this fadeout.

### **Fading**

As distinct from fade-out, fading is the constant variation of the received strength of radio wave. To the listener it appears as gradual rising and falling of the volume. The signal waxes and wanes and at times even drops below usable values. This phenomenon is manifested chiefly in long-distance transmission. It is caused by multiple reflections from the ionosphere which cause two or more waves from the same transmitter travel over different paths of different lengths and hence differ in phase and amplitude when they arrive at the receiving aerial.

## **G. Aerials**

### **A General Note on Aerials**

Aerial or antenna is a device, which acts as the mouth and ear of a radio transmitter or receiver respectively. Though we don't notice any external aerial in many of the commercial radio sets, they in fact, have aerials in built within the cabinets holding their electronic circuitry. But a ham radio operator is mainly concerned with an external outdoor antenna without which he can't expect to radiate radio energy into space from his radio transmitter. Similarly, without an external outdoor antenna, his radio receiver will not be able to pick up the radio waves speeding across the sky. A radio receiver might not need an external outdoor aerial to receive high power radio transmissions. But most of the ham radio transmitters use considerably low power (compared to the broadcast radio stations) which necessitates the use of outdoor aerials. A low power transmitter with an efficient antennae system or a less sensitive receiver with efficient antennae system can be made to work beyond imagination!

The aerials are usually made out of metallic rods or wires which are cut into specific lengths. The aerial should not be placed behind any obstruction, conducting materials such as tin-roof, ferro-concrete and to lesser extent foliage when wet. The

aerial should be as high as practical above the ground and grounded objects such as metal roofs, power or telephone wires etc.

### Different types of antenna system used by ham radio operators:

- (1) Horizontal Dipole,
- (2) Inverted -V dipole,
- (3) Yagi beam,
- (4) Ground plan vertical,
- (5) Cubical quad

Horizontal dipole is a very popular antenna, which is also easier to construct and erect. Two supporting structures are (e.g. two bamboo poles) required to erect a simple horizontal dipole antenna, whereas an inverted 'V' dipole antenna requires only a single pole which supports the feed-point of the dipole.

### Working function of a horizontal dipole antenna

A horizontal dipole antenna is a resonant antenna, which is half-wavelength long. Resonant circuits are well-known in radio engineering as combination of coils and capacitors, which cause a signal gain at certain frequencies. The same is applied to a half-wave dipole antenna.

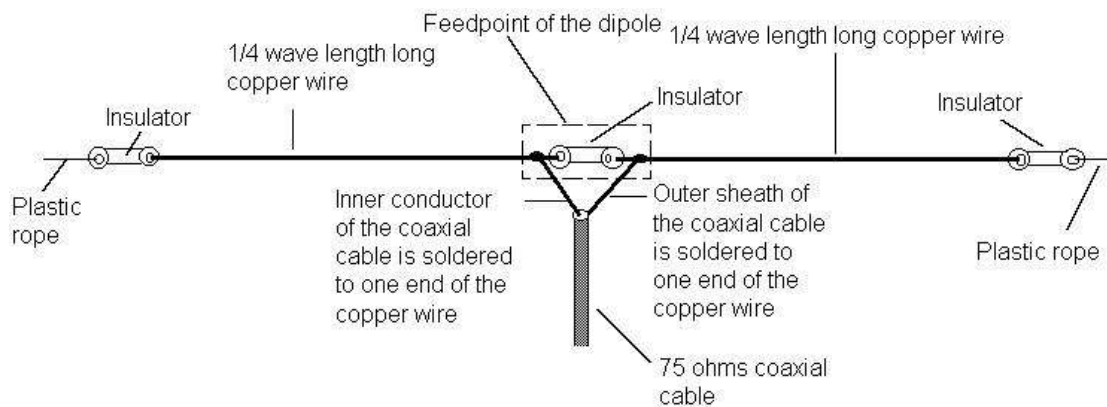

**A practical dipole antenna**

It consists of two straight wire or rod sections, each  $1/4$  wave long and positioned in one line (collinear). The antenna is fed in the centre by a coaxial cable having a characteristics impedance of 50 Ohms or 75 Ohms.

The maximum radiation direction is perpendicular to the axis from the middle point. The cause of directional radiation by a resonant  $1/2$  wave dipole antenna is that the radiation intensity is proportional to the square of the current in the antenna, and in the dipole current is maximum at the middle; hence the maximum radiation line passes through the middle of the antenna perpendicularly.

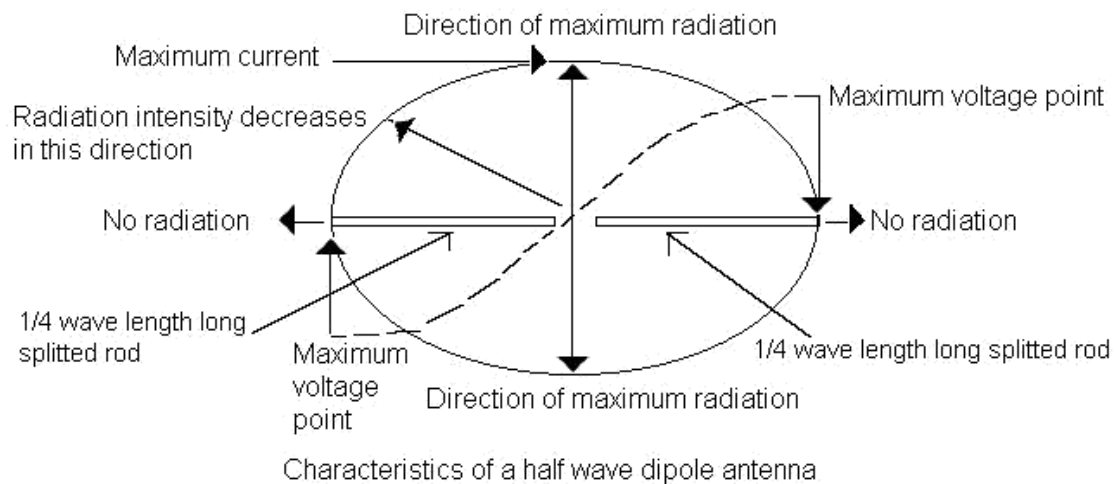

### Why half-wave dipoles are fed at the centre?

Most half-wave dipoles are fed at the centre, because in a half-wave resonant dipole, maximum current point is at the centre of the antenna and this is the minimum voltage point. It is easier to construct transmission lines for low voltage than for high voltage.

The other reason is that in a  $\lambda/2$  wave dipole, the capacitive reactance and inductive reactance cancel each other (the antenna being resonant), leaving resistance only as net impedance. Under this condition, the antenna impedance is the resistance between any two points equidistant from the centre along the antenna length making it easier to match the transmission line impedance with the antenna impedance.

### What is VSWR (Voltage Standing Wave Ratio) ?

When the transmission line does not match the load impedance (antenna impedance), maximum transference of energy to the antenna is not possible. The energy fed down the line is transferred to the antenna only partially; in fact, some is reflected back, forming standing waves on the line. Every half-wave along the line, high-E (Voltage) and Low-I (Current) points appear. Halfway between these two points will be Low-E and High-I points.

The ratio of voltage across the transmission line at the high-E point to that at Low-E points is called the VSWR.

$$VSWR = \frac{E_{\max}}{E_{\min}}$$

Or,

$$SWR = \frac{I_{\max}}{I_{\min}}$$

The SWR is also equal to the ratio of the characteristic impedance of the transmission line to the impedance of the antenna (load), or vice versa. For example, if the line has a characteristic impedance of 300 ohms and antenna impedance is 50 ohms, the SWR is  $300/50$ , or 6. A higher SWR indicates a greater mismatch between the transmission line and the antenna.

When the load (antenna) impedance matches the transmission line impedance, there will be no standing waves.

SWR=1:1 or 1

VSWR is greater than one for a mismatched system and equal to one for a perfectly matched system.

VSWR on a transmission line is caused by power being reflected back to the transmitter from the antenna. If  $P_F$  is the forward power and  $P_R$  is the reflected power measured in watts by a directional wattmeter, then VSWR can also be calculated by the formula:

$$VSWR = \frac{1 + \sqrt{P_R/P_F}}{1 - \sqrt{P_R/P_F}}$$

### What is 'radiation resistance'?

When an antenna is excited into oscillation by a RF source, it radiates energy into space acting as a source of power. The antenna, which is the source of power must have an internal resistance or impedance.

We have-

$$\text{Power, } P = I^2 R,$$

Where I=current, R=resistance

$$\text{Or, } R = P / I^2$$

So in case of the antenna, radiation resistance is the **ratio of the radiated power to the square of the centre current in the antenna.**

Radiation resistance is also defined as a **fictitious resistance**, which when substituted for the antenna would consume as much power as the antenna radiates.

Radiation resistance is also called '**Feed-point impedance**'; in case of a dipole antenna feed point impedance is nearly 73 Ohms.

### Why impedance matching is necessary in an antenna and transmission line system?

Impedance matching is of utmost importance so far as energy transference from the transmitter to the antenna through the transmission line is concerned; because, mismatching will prevent maximum output being radiated, i.e. if the transmission line impedance doesn't match the antenna feed-point impedance, a part of the energy fed down the line will be reflected back from the antenna causing standing waves on the line; it makes the system inefficient.

Mismatching a transmission line to an antenna results in the line at the transmitter end appearing to have either inductive reactance ( $X_i$ ) or capacitive reactance ( $X_c$ ), which will detune the inductance-capacitance (LC) circuit to which it

is coupled; mismatching should be avoided so that final stage of the RF amplifier is not detuned.

In many of the commercial wireless equipment, mismatching should be strictly avoided to prevent damage of the circuitry.

### What is a current fed antenna?

There are many methods of feeding energy to an antenna. The antenna is said to be current fed when excitation energy from the RF-generator is introduced to the antenna at the point of high circulating currents. The example is a  $\frac{1}{2}$  wave dipole antenna. In this case, the  $\frac{1}{2}$  wave antenna is cut in two parts at the midpoint and energy is fed by co-axial transmission line.

**In a dipole antenna maximum current flows through the middle point, hence it is current fed antenna** with a characteristic feed point impedance of about 73 ohms, which is considerably small as compared to end point impedance of the antenna. Midpoint is the low-voltage point.

### What is a voltage fed antenna?

When the excitation energy from the RF source is introduced at the point of maximum voltage, the antenna is said to be voltage fed antenna. The example is the  $\frac{1}{2}$  wave unsplit rod antenna excited by a resonant R-F line. Voltage changes at this point excite the antenna into oscillation. The impedance at the end of the antenna is high or it is the high impedance point.

Any multiple of a  $\frac{1}{2}$  wave resonant antenna may be end-fed by using a tuned feeder system leaving one end of the feed-line unconnected. This antenna is also called Zepp (used earlier on Zeppelins) antenna.

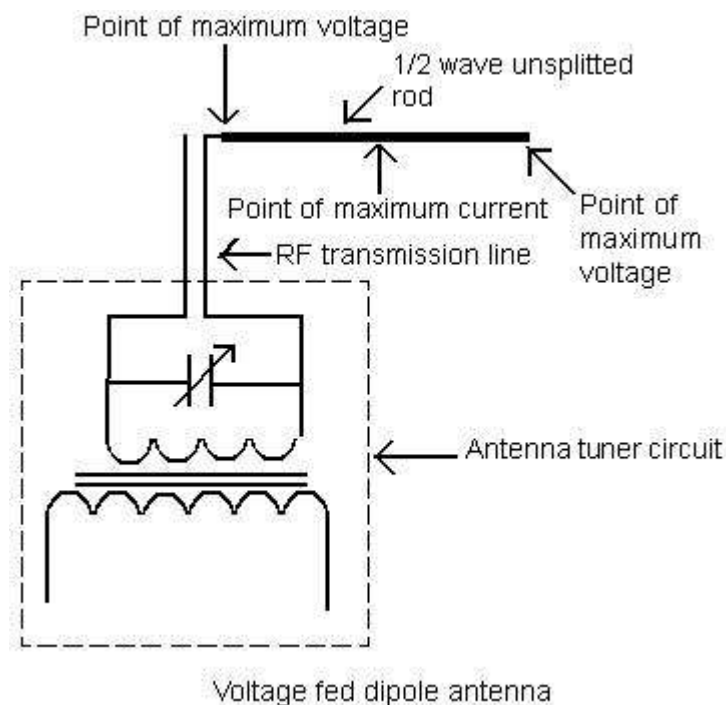

### Different types of antenna system impedance matching procedure

(a) Using the **proper transmission line** for each particular antenna is a way of achieving impedance matching. For example, a  $\frac{1}{2}$  wave dipole has a midpoint impedance of 73 ohms, so coaxial cable transmission line which has a characteristic impedance of 75 ohms is used to feed the R-F energy into the antenna.

(b) **Delta match:** This type of matching procedure is used with an unsplit  $\frac{1}{2}$  wave dipole antenna; the dipole being resonant, its capacitive reactance ( $X_C$ ) and inductive reactance ( $X_L$ ) cancel each other, leaving resistance only as net impedance. Under this condition, the antenna impedance is the resistance between any two points equidistant from the centre and thus transmission lines having characteristic impedance of 300 to 600 ohms be used by getting two points of the antenna to feed where it offers a feed point impedance equal to transmission line impedance.

To do so, it is essential to spread out the feeders at the antenna end.

The formula used to make this type of matching are :

$B = (0.25 \times \text{Wavelength})/2$ ; where B is the distance between the two feed point which will offer 600 ohms impedance.

And  $C = (0.32 \times \text{wavelength})/2$ , where C is the vertical distance upto which spreader should be spread (the inclination).

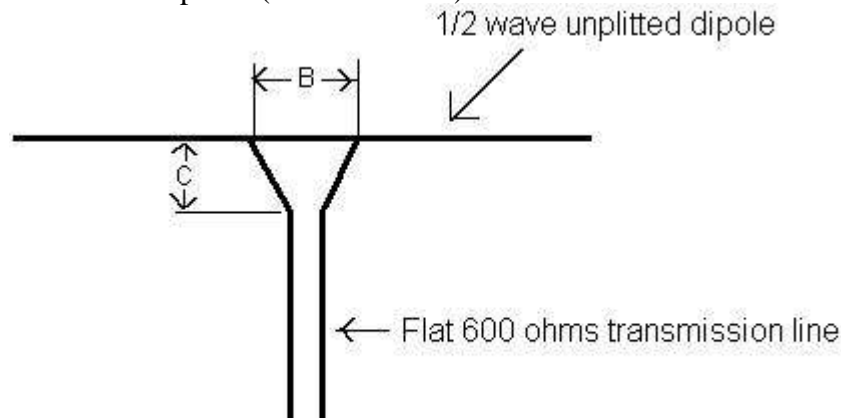

Delta fed dipole antenna

(c) **Stub Match :** A shorted stub of  $\frac{1}{2}$  wave length or open stub of  $\frac{1}{4}$  wave can be connected to the splitted dipole. Here the low midpoint impedance of 73 ohms of the dipole is repeated at the close end of the stub; but there are certain points on the stub which would offer as high as 600 ohms impedance yet matching with 73 ohms feed point.

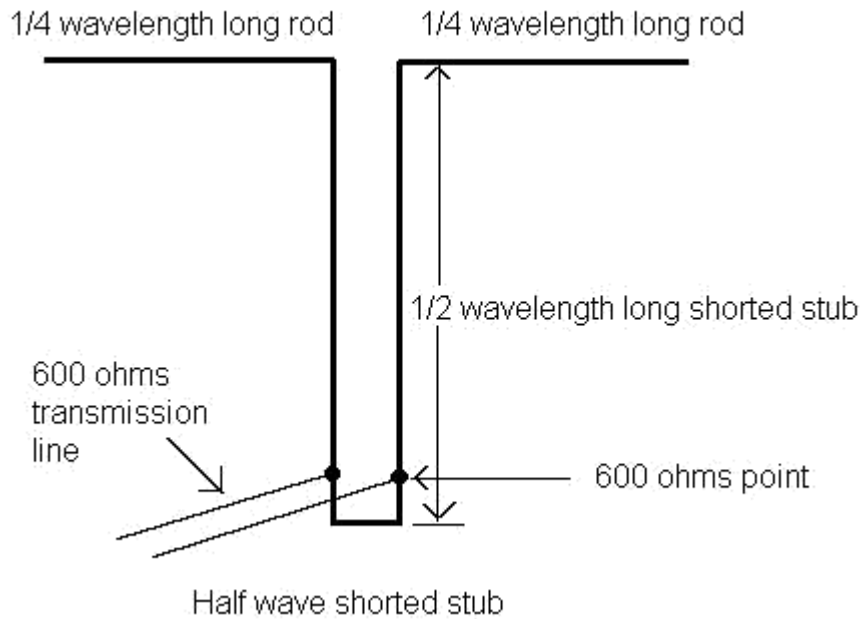

- (d) **Gamma Match:** Here outer sheath of the 75 ohms coaxial cable is connected to the middle point of the unsplit dipole, while the inner conductor is connected to a point through a capacitor to cancel inductive reactance, so that antenna impedance at feed point is 75 ohms. Gamma match is slightly unbalanced.

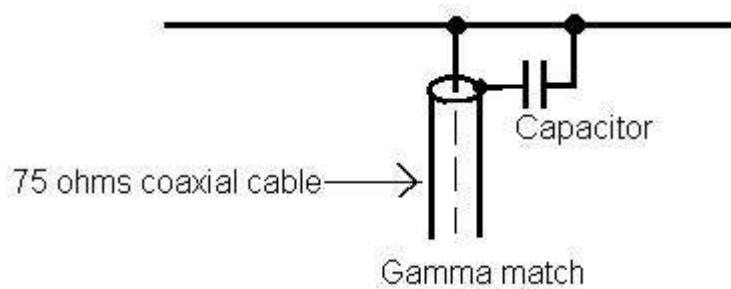

- (e) **T-Match:** In this type of impedance matching, two coaxial cables are held side by side and both their outer sheaths are connected to the midpoint of the unsplit dipole, while two points are chosen on the dipole where inner conductors going parallel to each other (of the coaxial) are connected.

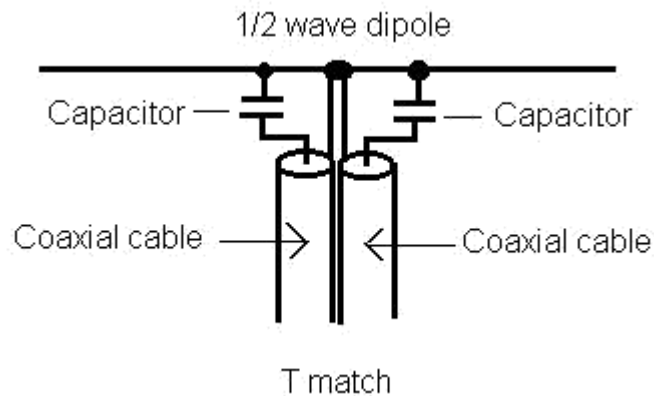

- (f) **1/4 wave transmission line impedance matching device:** A 1/4 wave line can act as an impedance matching device between high and low impedance circuits if it has the proper intermediate impedance found from the formula:  $Z = \sqrt{Z_1 \cdot Z_2}$

Where  $Z_1$  = antenna feedpoint impedance;  $Z_2$  main transmission line impedance. When we want to match a 300 ohms transmission line to a 70 ohms feed point impedance dipole antenna, then the 1/4 wave transmission line connected between both the system should have  $Z = \sqrt{300 \times 70} = 145$  ohms

### What is a Yagi antenna?

When a half wave dipole antenna consists of one or more parasitic arrays, the antenna becomes parasitic beam antenna, named as "Yagi" after its designer Proff. Yagi, Japan.

The antenna consists of mainly three elements, the **1/2 wave splitted dipole driven element (either folded or straight)**, in front of this driven element is the 5% shorter **director element**, back of the driven element is the 5% longer **reflector**. All the elements can be assembled on a **single conducting boom**. This antenna beams radio signals in the direction of the director and theoretically no signals to the backward direction. Yagi antenna is most commonly used for very high frequency (VHF) work. Because of shorter wavelengths, it is easier to construct a Yagi antenna for VHF work than the HF work. Instead of using a folded dipole (the driven element), as shown below in the diagram, the driven element can be kept unfolded (straight). In that case, the feed-point impedance of the antenna would be around 75  $\Omega$ .

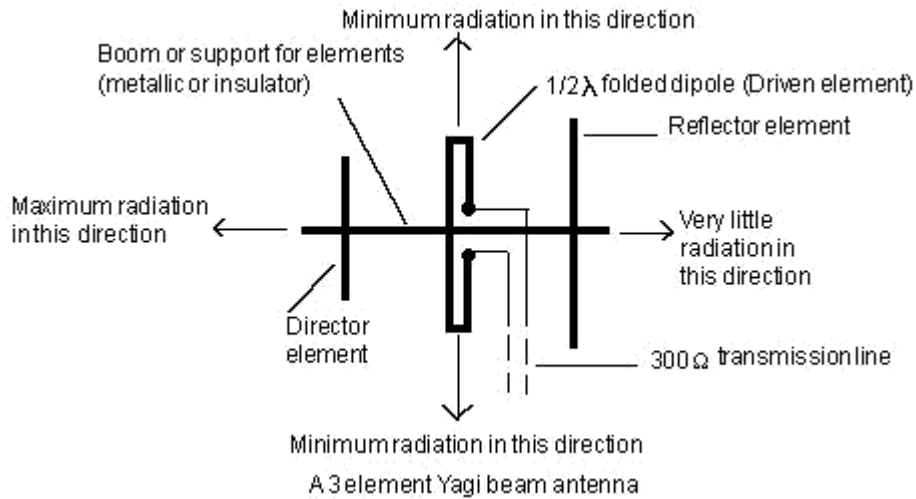

## Part-IV

### Study material to learn Morse Code

#### The International Morse Code

The telegraphic code used for amateur radio telegraphic communication is the International Morse Code consisting of dot (.) and dashes (-). In Morse Code a dot (.) is made by pressing the telegraph key down and allowing it to spring back up again rapidly; and for making a dash (-), the key is held down for a bit longer period. It is said that a dash(-) unit is three time longer than a dot(.) unit. The Morse Code in fact consists of combinations of aurally distinguishable tones. A tone produced for short duration is a dot tone and a tone three times longer than this tone is a dash tone.



#### A Morse Key

To practice Morse Code sending, a novice can use a small device called the 'Code Practice Oscillator' (CPO). This is a small electronic circuit capable of generating a sinusoidal audio tone when a key (or switch) is made 'on' or 'off' manually. The circuit of a CPO shown below can be easily assembled by a novice.

A freeware computer software can be downloaded from <http://www.florl.org/program/cwplayer.zip> . This software can generate Morse Codes for Morse code receiving practice.

### Code Practice Oscillator

A Code Practice Oscillator (CPO) can be used to practice Morse code. Given below is the circuit diagram of a Code Practice Oscillator (CPO) which we shall

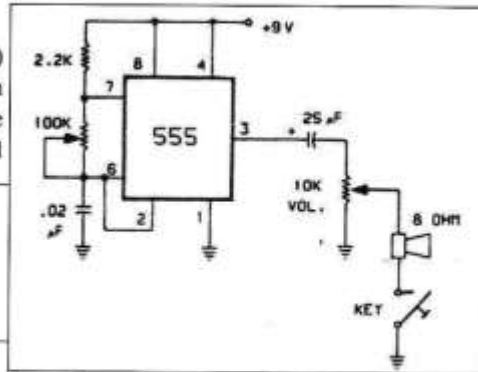
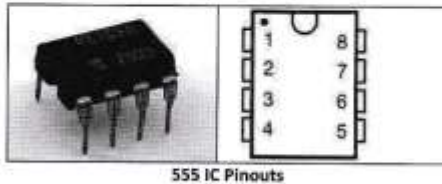

Code Practice Oscillator (CPO)

assemble. The circuit produces audio tones. We can use a Morse Key as a switch to produce Morse codes. Here we are using a small push button switch in place of the key. It uses a very few electronic components and can be very easily assembled.

It is advisable not to start practice sending the Morse code until the novice is proficient in receiving Morse code. For receiving practice, you have to rely on a ham radio operator who can send/generate Morse code using a CPO or you can try to find out Morse Code transmissions over your radio receiver. Morse code practice cassettes and multimedia computer software are nowadays available. Mere gaining confidence in sending does not qualify you to be an expert receiver! In fact you may not be able to receive a single letter in Morse code even if you gained a sending proficiency of 12 words Per Minute (WPM)! Remembering the Morse codes is an art by itself. It involves a rhythmic response in your mind. Try to remember the combination of dot (.) and dashes (-) by their sound and not as a group of printed symbols. For this purpose, a dot (.) is referred to as a 'di' and a dash (-) as a 'dah'. A 'di' coming at the end of the combination is pronounced as 'dit'

The letter 'R' is represented by '. - .' (*di dah dit*) in Morse code. The time taken to produce the sound equivalent to one 'di' or 'dit' (dot) is taken as unit time and called a dot unit. A 'dah' is approximately of three dot units length and the space between two sound elements of a letter is one dot unit, i.e. silence period is one dot unit. The space between two letters or characters is equal to three dot units. The space between two words is equal to five dot units. The word 'cat' can be represented as '-.-. .- -' (*dah di dah dit di dah dah*)

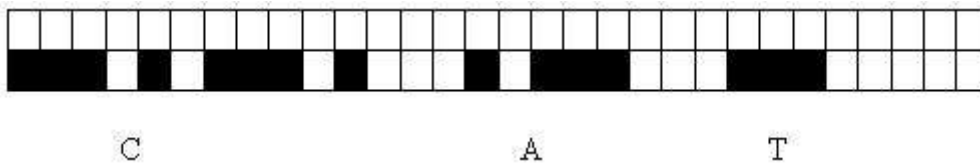

### Morse Code speed

The minimum speed to qualify for a Grade II licence is 5 words per minute (5 wpm). 5 letters/characters constitute a word. A message containing 125 letters when sent in 5 minutes or when received in 5 minutes makes your speed 5 wpm.

$125/5=25$  words in 5 minute; i.e. 5 words per minute.

In fact Morse code devised by **Samuel F.B. Morse** (1791-1872) is a primitive type of digital communication which still works efficiently in this era of microprocessors and computers.

Morse code is also called CW, i.e. **Continuous Wave**, in the sense that a constant amplitude interrupted radio frequency wave is transmitted; interruption being made in conformity with the code.

### **Analog and Digital methods**

The electrical telephone and telegraph are very simple examples which illustrates the difference between the analog and digital methods. In the telephone, the information is transmitted from one end to the other via a current which varies continuously as direct equivalent of sound waves striking the microphone-the analog approach. In the telegraph, the information is encoded (cyphered) and sent as a sequence of current/no current pulses illustrating the digital approach.

### **Why Morse code is still in use?**

It was deemed important that ham radio operators prove an ability to transmit and receive in Morse Code signals. In the last 50 years, however, the **International Telecommunication Union (ITU)** has reviewed and modified the amateur Morse Code requirement at every international conference capable of changing it. In 1947 (Atlantic City) the ITU agreed that Morse proficiency should only be required when the operation took place on frequencies below **1000 MHz** (1 GHz). At WARC-59 (The 1959 World Administrative Radio Conference) this level was dropped to **144 MHz**. A further reduction was made at WARC-79 to its presents **30 MHz**.

Despite the capability of voice communication, Morse code is still in use. One important reason is that a vast group of the radio amateurs still adore Morse code. **A ham radio operator employing digital communication techniques (like Packet Radio, Radio Tele Typing-RTTY or AMateur Tele-printing Over Radio-AMTOR) in his ham radio operation treats Morse code with much the same affection he has for those modern innovations!**

A ham radio operator wearing his headphone and the Morse Key in hand can send messages silently without disturbing his family members who might be sleeping comfortably!

Another reason is that short wave radio telephone (voice) signals often suffer very rapid and deep fading; two frequencies separated by only a few hertz, fade at different times. To overcome this, modulated code tones are transmitted. The situation is now that under severe conditions of fading, the carrier frequency may fade out completely but one or the other side band may remain strong as a result a continuously readable signal is received. This is the reason that we hear a band full of exotic sounding CW call-signs at any time of day or night. When the a band appears to be dead, and we can barely copy phone signals, the band remains alive with many CW signals.

### Why this be so?

- (i) The answer is that to communicate human speech, a wider bandwidth is required than that of the CW signal. With a smaller bandwidth the 'signal to noise ratio' of the receiver is significantly improved, and the threshold at which signals can still be received above the noise level is therefore extended.
- (ii) Also, it is possible for the human ear to be able to resolve CW signals which are only marginally above the noise level, whereas SSB signals of the same signal level could not be copied. It has been suggested that CW has an advantage of approximately 20dB over SSB signals. A narrow band-pass filter improves the CW reception.

### How to learn Morse Code?

Many newcomers seek exemption from 'tiresome' Morse test for Short wave operation. This is unfortunate as the Morse code is the key to enter into the world of ham radio with a very little monetary investment. A novice can assemble a simple Morse code transmitter with lesser technical hurdles than that of a SSB Voice transmitter. Morse code can be learnt easily if we use certain techniques to remember the codes. Learning the Morse code can also be considered as an entirely personal venture embarked upon by alone. Following points should be kept in mind while learning the Morse code-

- (1) Try to remember the codes from their sound.
- (2) Don't begin with a practice to send. Sending is much easier compared to receiving.
- (3) During receiving of a message, don't write down the 'dot' and 'dash' combinations. Directly write down the letters in running hand. Don't bother to know the content of the message. Just continue writing the letters one by one and leave a space when you are not sure about the letter. If you wait wondering about what the letter was, you would get stuck and in the process many letters would pass by you, which you would not be able to jot down.

### THE INTERNATIONAL MORSE CODE

A	· _	J	· _ _ _	S	· · ·	1	· _ _ _ _
B	_ · · ·	K	_ · _	T	_	2	· · _ _ _
C	_ · _ ·	L	· _ · ·	U	· · _	3	· · · _ _
D	_ · ·	M	_ _	V	· · · _	4	· · · · _
E	·	N	_ ·	W	· _ _	5	· · · · ·
F	· · _ ·	O	_ _ _	X	_ · · _	6	_ · · · ·
G	_ _ ·	P	· _ _ ·	Y	_ · _ _	7	_ _ · · ·
H	· · · ·	Q	_ _ · _	Z	_ _ · ·	8	_ _ _ · ·
I	· ·	R	· _ ·			9	_ _ _ _ ·
						0	_ _ _ _ _

### PUNCTUATIONS

· (Period)	· · · _ · ·	(AAA)
, (Comma)	_ _ · · _ _	(MIM)
? (Question mark)	· · _ _ · ·	(IMI)
; (Semicolon)	_ · _ · _ ·	(NNN)

- (Hyphen)	_ . . . . _	(BA)
Error sign	. . . . . . . .	(8 dots)
Sentence separation indicator	_ . . . . _	(BT)
End of transmission of a message	. _ . _ .	(AR)
Invitation to transmit	_ . _	(K)
Wait	. _ . . .	(AS)
End of work	. . . _ . _	(VA)

Almost all the letters/characters and punctuation marks can be arranged in certain groups which can be used to show the resemblance between/among the combination of *dot* and *dashes*. For example the letter 'A' (. \_ ) is the opposite of 'N' (\_ .). Similarly, the letters A, U, V and the character 4 can be made into a group which shows a definite sequence. Given below is a table of such combinations.

<b>A</b> . _	<b>T</b> _ _	<b>N</b> _ .	<b>E</b> . .
<b>U</b> . . _	<b>M</b> _ _ _	<b>D</b> _ . .	<b>I</b> . . .
<b>V</b> . . . _	<b>O</b> _ _ _ _	<b>B</b> _ . . .	<b>S</b> . . . .
<b>4</b> . . . . . _			<b>H</b> . . . . .
			<b>5</b> . . . . .
<b>W</b> . _ _ _	<b>Y</b> _ . _ _ _	<b>K</b> _ . . _	<b>P</b> . _ _ .
<b>G</b> _ _ .	<b>Q</b> _ _ . _	<b>R</b> . _ .	<b>X</b> _ . . _
<b>L</b> . _ . .	<b>A</b> . _	<b>D</b> _ . .	<b>B</b> _ . . .
<b>F</b> . . _ .	<b>N</b> _ .	<b>U</b> . . _	<b>V</b> . . . _

### Part-V

## Safety Measures in a Ham Radio Shack

Electricity is one of the most magnificent discoveries that the mankind has achieved since the dawn of civilization. We are now wholly dependent on this wonder of science. Without electricity our life will become miserable and probably the life will come to a standstill. It is the backbone of an industrialized society without which progress of a society can't even be dreamt of. Functioning of all the fields of science are wholly dependant on the availability of electricity including your ham radio! While electricity has made our life full of comfort and ease, it has also the potentiality to create heavy destruction if we do not take adequate precautions against its potential ills. A casual attitude towards the electricity should always be avoided.

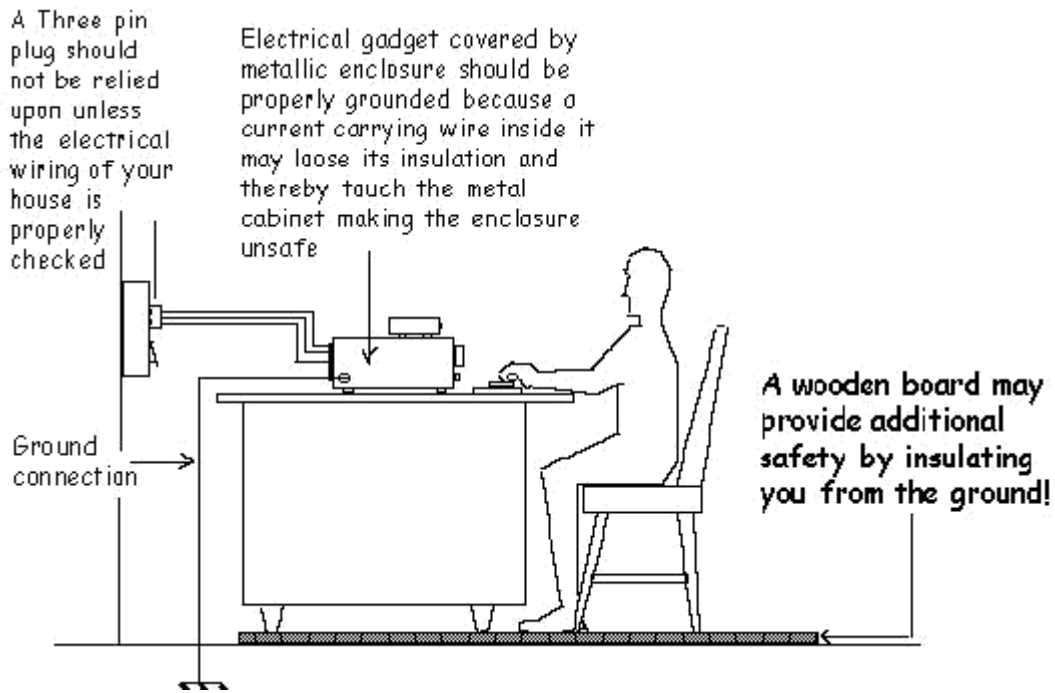

The ham should keep his wireless equipment in a protected place, so that, it can not be operated by any unauthorized person in his absence. All the equipment should be properly installed and precaution should be taken so that they don't create electrical hazards. For this and the safety of the other people in the house, equipment should have proper ground connection (an alternative path to the Earth). Though the switch board sockets have the facility to insert a three pin electrical plug (the male plug from our equipment), the wire connecting to the ground from the third hole of the socket may remain disconnected somewhere without our knowledge. This may create a risk to your life because the electrical equipment's current carrying wires are vulnerable to insulation breakdown due to many reasons.

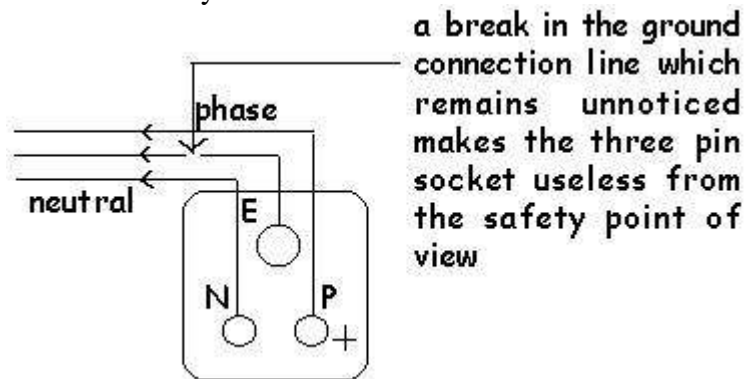

Under such circumstances, if a current carrying wire touches the metallic portion of the equipment, current will start flowing in that portion also. Under such a situation, if we touch an electrical gadget housed in a metallic enclosure, we may get electrocuted as well! In fact electrical currents seek for the paths of low resistance. In the above situation, if we are bare footed, then these electrical currents will find their easiest path to the Earth (Ground) through our body and simulate a close circuit situation. Our body will heat up (because the human body too offers resistance to the

flow of current) and we will die! In a different situation where the metallic portion of the electrical gadget is properly grounded with the help of a good conducting wire (e.g. copper), even if we touch the current carrying metallic portion, most of the current will flow through that grounded copper wire only causing less damage to our body. A part of the current will still find their path to the ground through our body because we are still bare footed! So the highest safety measure is to wear shoes made of insulated material (which do not conduct electricity) and keep us separated from the ground (the Earth). In this situation, even if we accidentally touch the current carrying metallic portion of the electrical gadget, current will not be able to find their path in to the ground through our body and we shall remain safe. In no case, the 'phase' (current carrying) and 'neutral' wires should be touched by your hand simultaneously. Doing so will create the most potential risk to your life, because, current from 'phase' to 'neutral' will now flow from one hand to the other hand (if you use both your hands to touch the 'phase' and 'neutral' !) through your body and you will be getting killed in the process!

So, always:

1. Check for **proper ground connection** in the electrical wiring of the house.
2. If possible connect an **extra conducting wire to the ground** (you can tightly tie the wire on to a water pipe) from the metallic enclosure of the electrical gadget.
3. **Don't touch electrical gadgets with wet hand.** Water reduces the resistance of the skin of our body and as a result electrical currents find their easy entry into our body!
4. Always wear **insulated shoes** (rubber, plastic etc.)
5. **A dry wooden board** can be kept on the floor which will provide additional insulation.
6. The electrical device should have a **'fuse'** as per the current rating of the device. For example, if the equipment is designed to allow a current of 5 ampere, the 'fuse' should also be rated 5 ampere. Any more current due to short circuit will blow the fuse and inactivate the equipment. This will prevent further damage of the equipment and other electrical wiring will remain safe.
7. There should be a **main switch** (called the "*Big Switch*"!) at your easy reach. While closing down your ham radio operation, this switch should be pulled to disconnect all the equipment at the same time. That is why, in ham terminology, many operator's use the phrase "*Pulling the Big Switch*" to indicate that he is closing down his station!
8. Now-a-days, **miniature circuit breaker** switches (MCB) are also available. This type of switches provide safety to the electrical gadgets connected to the electrical sockets by automatically disconnecting them from the current in the event of a short circuit in the electrical wiring.
9. The **fuses in the electrical meter box should not be tampered with.** A blowing fuse indicates that an electrical gadget is drawing more current than its specification. Alternatively, you may be using too much of electrical gadgets in your house resulting in a current flow which exceeds your allotted rating. In such a situation, if you increase the thickness of the fuse wire to prevent it from frequently burning down, the whole electrical wiring of your house will be at the risk of burning down.

**Government of India**  
**Ministry of Communications & I.T.**  
**Department of Telecommunications**  
**WPC Wing**

No. L-14011/255/2004-AMT

Dated: 13/8/2010

**Office Memorandum**

**Subject:** Guidelines and clarification in the context of Indian Wireless Telegraph(Amateur Service) Amendment Rules,2009 dated 1<sup>st</sup> April,2010 and Indian Wireless Telegraphs(Amateur Service)Amendment Rules,2005 dated 9<sup>th</sup> June,2005

The undersigned is directed to refer the amendment rules mentioned above and to inform that they have come into effect from the date of issue of the last amendment. i.e. from 1<sup>st</sup> April, 2010 onwards.

2. The following guidelines are being issued to bring clarity to all those Amateurs, existing as well as the prospective Amateurs in India in the light of the above amendments.

3. The major changes in the licensing rules are tabulated below that compares the position before and after the amendment.

Sl no	Category	Existing	As per Amendment
1	Licenser categories	1. Adv. Grade 2. Gr.I. 3. Gr.II. 4. Gr.II( R ) 5. SWL	1. General. 2. Restricted.
2	Examination Fee	Rs.10 (Rest. & Gr. II), Rs. 20(Gr.-I), Rs. 25 (Adv. Gr.)	Rs.100/- for each grade.
3	Period of Validity	2 and 5 years	20 years and lifetime.
4	Licence Fee	Rs. 25(Rest. & Gr.II),Rs. 40 (Gr.-I), Rs.50 (Adv. Gr.) for 2 years Rs. 60(Rest.& Gr.II), Rs. 40 (Gr.-I), Rs.50 (Adv. Gr.) for 5 years.	Rs.1000/- for 20 years and Rs. 2000/- for lifetime for each grade.
5	Renewal.	-----do-----	20 years and Rs.1000/-

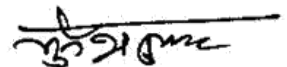

6	Period of late renewal and surcharge.	5 Years. Rs.10/- for every half year	5 Years. Rs.100/- for every half year or part thereof.
7	Fee for change of location:	Rs. 5/-	Rs.200/-
8	Fee for mobile endorsement:	Rs. 10/-	Rs.200/-
9	Fee for issue of duplicate of licence:	Rs. 10/-	Rs. 100/-
10	Fee for duplicate of renewal licence slip:	Rs. 5/-	Rs. 100/-

4. The existing Grade II and Restricted category shall be migrated to the new 'Restricted' category at the time of their next renewal after the payment of revised fees for 20 years or lifetime as the case may be at the request of the applicant. This is also applicable to those whose case sheets are pending at WPC for issue of new license. The old license type will be indicated in their license to distinguish them from those who seek licensee afresh based on the new notification.

5. It is also desired that those who apply for the renewal should register in the WPC website and file their application 'online' also. The request for renewal should enclose the Acknowledgement slip for the 'online' submission along with the demand draft and other documents.

6. Those who have qualified in the Amateur examination and yet to receive the license may receive a communication from this Ministry for the payment of revised fees. This letter shall be issued only after the Intra-Ministerial clearance is received from the concerned Ministry. It is therefore requested that the license fees should not be sent without receiving any letter from this Ministry.

7. Those licensees who have already applied for renewal and who are yet to receive the renewal certificate may send the request along with the necessary fees. i.e. Rs.1000 for 20 years and Rs.2000 for Lifetime. The option for 20 years or lifetime should be clearly mentioned in the application form.

8. The frequency, emission and power authorized to the Amateurs in India have been revised as per Annexure-I. These are issued in the light of the NFAP 2008, which is already available on the WPC website.

9. The NFAP review committee is periodically meeting to discuss the changes that are required in the spectrum management in India considering the technical changes that happens in India, Industrial development/technological transfers into India, ITU

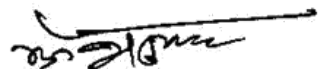

regulations etc. The Amateur clubs who advocate the causes of the Amateurs are requested to actively participate in this committee to put forward any new proposals with regard to the frequency bands, power of transmission etc used by Amateur in India. No proposal shall be considered by WPC unless it is accepted by the NFAP review committee.

10. The revised syllabus for the Amateur is placed at Annexure II of this OM. The exams as per the new pattern shall be conducted by the various Wireless Monitoring Stations. The applicants may contact the respective Monitoring stations for the schedule of the examination.

11. The call-sign block VU2 shall be reserved for "General" grade and block VU3 to "Restricted" Grade for future licences.

12. This O.M shall supercede the "Frequency bands, Emission and Power that was notified by WPC Wing through its notification dated 4<sup>th</sup> October 1985.

13. For further clarification, comments if any, the undersigned may be contacted.

Encl: As above

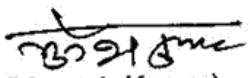
  
(Munesh Kumar)  
Assistant Wireless Advisor.

To,  
All concerned

Copy to:

1. Director (WM), Wireless Monitoring Headquarters, Pushpa Bhawan.
2. Engineer-in-Charge(ER/WR/NR/SR)
3. JWA/DWA Regional Licensing Office, Delhi, Mumbai, Chennai, Kolkata, Shillong.

Annexure-I

Category of License (New) and Bands	Frequency bands	Emission	Max DC Input Power unless Otherwise specified	Remarks
Restricted Grade	1820-1860* KHz	A3E,H3E, J3E,R3E	50 watts	Old "Grade II" Licensees are also authorized to use A1A emission in these bands.
	3500-3700* KHz			
	3890-3900* KHz			
	7000-7100KHz			
	7100-7200 KHz			
	14000-14350 KHz			
	18068-18168\$ KHz			
	21000-21450 KHz			
	24890-24990\$ KHz			
	28000-29700 KHz			
	50-54 MHz	F1B,F2B, F3E,F3C	10 Watts	
144-146 MHz	-Do-	10 Watts	Old "Grade II" Licensees are also authorized to use A1A and A2A emissions in these bands	
434-438@ MHz				
General Grade	1820-1860* KHz	A1A,A2A,A3E,H3E, J3E,R3E, F1B,F2B, F3E,F3C, A3C,A3F	400 Watts	
	3500-3700* KHz			
	3890-3900* KHz			
	7000-7100 KHz			
	7100-7200 KHz			
	14000-14350 KHz			
	18068-18168\$ KHz			
	21000-21450 KHz			

General Grade	24890-24990\$ KHz	A1A,A2A,A3E,H3E, J3E,R3E, F1B,F2B, F3E,F3C, A3C,A3F	400 Watts	
	28000-29700 KHz			
	50-54 MHz	F1B,F2B, F3E,F3C	25 Watts	
	144-146MHz	-Do-	25 Watts	
	434-438@MHz	-Do-	25Watts	
	<u>5725-5840@MHz</u>			

\* On primary shared basis as per the relevant provision of Radio Regulations.  
 \$ Authorization is on non-interference and non protection basis.  
 @ On secondary basis as per the relevant provisions of Radio Regulations.

**Note:**

- (i) All the allocation subject to the relevant provisions of the Radio Regulations. Amateur satellite service is permitted for General Grade in the appropriate sub bands in accordance with Radio Regulations and in those cases the maximum output RF power (eirp) is 30 dBw.
- (ii). The above authorization is subject to site clearance as per the procedure prescribed by the Standing Advisory committee on Radio frequency allocation (SACFA) as applicable.
- (iii) For A3F emission, the transmission shall be restricted to call-sign of the station, location and other particular of the station. They shall be limited to point to point test transmission employing a standard interlace and scanning with a bandwidth not more than 4 KHz.
- (iv) DC input power is the total direct current power input to the final stage of the transmitter.

**Annexure II**

**SYLLABUS**

**SYLLABUS AND THE DETAILS OF EXAMINATIONS FOR THE AWARD OF  
AMATEUR STATION OPERATOR'S LICENCE (Restricted) and (General)**

**1. The examination shall consist of the following two parts:**

**PART I - Written Test**

It shall comprise of one paper containing two sections as under:

**Section A: Radio Theory and Practice**

**Note-** Applicants holding degree in Engineering/Science or Diploma in Engineering and having studied electronics or telecommunications shall be exempted from appearing in Section A of Part-I of the test.

**Section B: National and International Telecommunication Union (ITU) Radio Regulations applicable to the operation of amateur station and those relating to the working of station generally.**

**PART II -- Morse (Only for General Certificate)**

**Morse reception and sending (8 wpm)**

**2. Detailed syllabus:**

**2.1 Amateur Station Operator's Licence (Restricted) Examination**

**Part I – Written Test**

**Section A: Radio Theory and Practice:**

**(i) Elementary Electricity and Magnetism:**

1. Elementary theory of electricity- Passive Devices (Resistors, Inductors, Transformers, Capacitors) and Active Devices (Diodes, Transistors).
2. Kirchoff's current and voltage laws- Simple applications of the law.
3. Conductors and Insulators – Properties, units of circuit elements, Ohm's Law.
4. Conductance – Definition of self and mutual inductance,
5. Power and energy- Definition, Units and simple applications.
6. Permanent magnets and electromagnets – Definition, properties and their use.

**(ii) Elementary Theory of Alternating Currents:**

1. Sinusoidal alternating quantities -- Definition of peak, instantaneous, R.M.S., average values and its simple application.
2. Phase, reactance, impedance, power factor- Definition, units and simple applications.
3. Parallel and Series Circuits - series and parallel circuits containing resistance, inductance, capacitance, resonance in series and parallel circuits, coupled circuits.
4. Rectifiers, voltage regulation and smoothing circuits - Their basic knowledge and simple application.

**(iii) Elementary theory of Semiconductor Devices:**

1. Diodes and transistors- Properties use of these devices for construction of amplifiers, oscillators, detectors and frequency changers.

**(iv) Radio Receivers :**

1. Principles and operation of T.R.F. and super heterodyne receivers.
2. CW reception.

3. Receiver characteristics-sensitivity, selectivity, fidelity, adjacent channel and image interference, A.V.C. and squelch/circuits, signal to noise ratio.

**(v) Transmitter :**

1. Principles and operation of low power transmitter, crystal oscillators, stability of oscillators.
2. Basic knowledge about construction of Semiconductor based transmitters.

**(vi) Radio Wave Propagation:**

1. Basic knowledge of Electromagnetic Spectrum.
2. Wave length, frequency, frequency bands.
3. Nature and propagations of radio waves, ground and sky waves, space waves, skip distance, skip zone and fading.

**(vii) Aerials:** Common types of transmitting and receiving aerials.

**(viii) Frequency Measurement:** Measurement of frequency and use of simple frequency meters.

**Section B: Radio Regulations:**

**(a) Knowledge of :-** (i) the Indian Wireless Telegraph Rules, 1973.

(ii) the Indian Wireless Telegraphs (Amateur Service) Rules, 1978 and amendments.

**(b) Knowledge of ITU Radio Regulations** as relating to the operation of amateur stations with particular emphasis on the following:

Item	Provision of Radio Regulation (2008 edition)
Designation of Emission.	Appendix-I
Phonetic alphabets and figure code.	Appendix 14
Nomenclature of the Frequency & Wavelength.	Article 2
Frequency allocation for Amateur Services.	Article 5

Interference, measures against interference & tests.  
Identification of Stations.  
Distress Signal, Call and Message. Transmissions.  
Urgency Signal, Call and Message Transmissions.  
Amateur Station.  
Call Sign series allocated to India.

Article 15  
Article 19.  
Article 30, 31, 32 & 33.  
Article 30, 31, 32 & 33.  
Article 25  
Appendix 42

---

(c) Standard Frequency and Time Signals Services in the World.

(d) The following 'Q' codes and abbreviations shall have the same meaning as assigned to them in the Convention.

QRA, QRG, QRH, QRI, QRK, QRL, QRM, QRN, QRQ, QRS, QRT, QRU, QRV, QRW, QRX, QRZ, QSA, QSB, QSL, QSO, QSU, QSV, QSW, QSX, QSY, QSZ, QTC, QTH, QTR, and QUM.

Abbreviations: AA, AB, AR, AS, C, CFM, CL, CQ, DE, K, NIL, OK, R, TU, VA, WA, WB.

**Note: -**

1. The written test will be of **one hour** duration. The maximum marks will be 100 and candidate must secure at least **40 %** in each section and **50%** in aggregate for a pass.
2. There will be **NO Morse test for restricted grade.**

**2.2. Amateur Station Operators' License (General) Examination**

**Part I - Written Test**

**Section A: Radio Theory and Practice**

In addition to the syllabus prescribed for Amateur Station Operator's License (Restricted) examination, following items shall be included in the syllabus of Amateur Station Operators' license (General) examinations:-

- (i) **Principles of Communications:**

1. Elementary idea of analog and digital communication.
2. Need for modulation; Modulation- amplitude, frequency and pulse modulation.
3. Elementary idea about demodulation.

**(ii) Alternating current:**

1. Basic concepts on construction of transformers.
2. Definition of Transformer losses.
3. Transformer as a matching device

**(iii) Semi Conductor devices and Transistors:**

1. Elementary principles of conduction and construction;
2. Symbols and biasing methods.

**(iv) Power Supplies:**

1. Basic knowledge of half wave and full wave rectifiers.
2. Definition and application of Bridge rectifier, smoothing and regulating circuits.

**(vii) Transmitters and Receivers:**

1. Elementary principles of transmission and reception of Facsimile and Television signals,

**(viii) Propagation:**

1. Characteristics of ionosphere and troposphere.
2. Properties of ionosphere layers.
3. Critical frequency and day / night frequencies.

**(ix) Aerials:**

1. Principles of radiation.
2. Aerials for different frequency bands including aerials for microwave,

(x) **Space Communications:**

1. Elementary principles of communication via satellites.

**Section B: Radio Regulations:**

Same syllabus as prescribed for Amateur Station Operators' License (Restricted) examination.

The above written test will be of **two hour** duration. The maximum marks will be 100. A candidate must secure at least 50 % in each section and 60% in aggregate for a pass.

**Part II - Morse**

**Morse receiving: (Speed: 8 words per minute)**

The test piece will consist of a plain language passage of 200 characters which may comprise of letters, figures. Test piece may also contain the following punctuations ie full stop; comma; semi colon; break-sign; hyphen and question mark. The average words shall contain five characters and each figure and punctuation will be counted as two characters. The test will be for five consecutive minutes at a speed of 8 words per minute. A short practice piece of one minute shall be sent at the prescribed speed before the start of the actual test. Candidates will not be allowed more than one attempt in Morse reception and sending test. The test may be written in ink or pencil but must be legible. Over-writing will be treated as error. If any correction is required the candidate may struck the wrong character and write the correct above the character. More than 5 errors will disqualify a candidate. However if a candidate receives without any error in any part of the passage continuously for one minute duration will be declared successful in the Morse reception test.

**Morse Sending (Speed: 8 words per minute)**

The test piece will be similar to Morse Receiving test for Amateur Station Operators' License (General) examination. Candidates are required to send for five consecutive minutes at a speed not less than 8 words per minute. Other conditions are the same as applicable to Amateur Station Operators' License (General) examination.

**Note-** A candidate shall have to pass both receiving and sending simultaneously.















AMATEUR RADIO EXAM QUESTION PAPER SAMPLE

RULES & REGULATIONS -Operating procedures

1. Which emission mode must be used to obtain assistance during a disaster?
  - a) Only SSB
  - b) Only SSB and CW
  - c) Any mode
  - d) Only CW
2. What should you do if a CW station sends "QRS" when using Morse code?
  - a) Send slower
  - b) Change frequency
  - c) Increase your power
  - d) Repeat everything twice
3. What is the recommended way to break into a conversation when using phone?
  - a) Say "QRZ" several times followed by your call sign
  - b) Say your call sign during a break between transmissions from the other stations
  - c) Say "Break" "Break" "Break" and wait for a response
  - d) Say "CQ" followed by the call sign of either station
4. Which of the following 20 meter band segments is most often used for most data transmissions?
  - a) 14.000 – 14.050 MHz
  - b) 14.070 - 14.100 MHz
  - c) 14.150 - 14.225 MHz
  - d) 14.275 - 14.350 MHz
5. What action should be taken if the frequency on which a net normally meets is in use just before the net begins?
  - a) Reduce your output power and start the net as usual
  - b) Increase your power output so that net participants will be able to hear you
  - c) Ask the stations if the net may use the frequency, or move the net to a nearby clear frequency if necessary
  - d) Cancel the net for that day
6. Which of the following is an advantage when using single sideband as compared to other voice modes on the HF amateur bands?
  - a) Very high fidelity voice modulation
  - b) Less bandwidth used and high power efficiency
  - c) Ease of tuning on receive
  - d) Less subject to static crashes (atmospherics)
7. What is an azimuthal projection map?
  - a) A world map projection centered on the North Pole
  - b) A world map projection centered on a particular location
  - c) A world map that shows the angle at which an amateur satellite crosses the equator
  - d) A world map that shows the number of degrees longitude that an amateur satellite appears to move westward at the equator with each orbit
8. How do you call another station on a repeater if you know the station's call sign?
  - a) Say "break, break" then say the station's call sign
  - b) Say the station's call sign then identify your own station
  - c) Say "CQ" three times then the other station's call sign
  - d) Wait for the station to call "CQ" then answer it
9. The frequency of 40 Meter band in MHz is
  - a) 14 - 14.350
  - b) 7 - 7.2
  - c) 21 - 21.450
  - d) 15 - 15.400
10. Which sideband is commonly used in the VHF and UHF bands?
  - a) Upper Side Band
  - b) Lower side band
  - c) Vestigial side band
  - d) Double side band
11. When are you prohibited from helping a station in distress?

- a) When that station is not transmitting on amateur frequencies
  - b) When the station in distress offers no call sign
  - c) You are never prohibited from helping any station in distress
  - d) When the station is not another amateur station
12. What is a practical way to avoid harmful interference when calling CQ using Morse code or CW?
- a) Send the letter "V" 12 times and then listen for a response
  - b) Keep your CQ to less than 2 minutes in length to avoid interference with contacts already in progress
  - c) Send "QRL? de" followed by your call sign and listen for a response
  - d) Call CQ at low power first; if there is no indication of interference then increase power as necessary
13. What does it mean when a CW operator sends "KN" at the end of a transmission?
- a) Listening for novice stations
  - b) Operating full break-in
  - c) Listening only for a specific station or stations
  - d) Closing station now
14. Who is accountable if a repeater station inadvertently retransmits communications that violate WPC rules?
- a) The repeater trustee
  - b) The repeater control operator
  - c) The transmitting station
  - d) All of these answers are correct
15. Which of the following statements is true of the single sideband (SSB) voice mode?
- a) Only one sideband and the carrier are transmitted; the other sideband is suppressed
  - b) Only one sideband is transmitted; the other sideband and carrier are suppressed
  - c) SSB voice transmissions have higher average power than any other mode
  - d) SSB is the only mode that is authorized on the 160, 75 and 40 meter amateur bands
16. Which layer of ionosphere disappears during night time?
- a) F
  - b) E
  - c) D
  - d) C
17. When sending CW, what does a "C" mean when added to the RST report?
- a) Chirpy or unstable signal
  - b) Report was read from S meter reading rather than estimated
  - c) 100 percent copy
  - d) Key clicks
18. How do you call another station on a repeater if you know the station's call sign?
- a) Say "break, break" then say the station's call sign
  - b) Say the station's call sign then identify your own station
  - c) Say "CQ" three times then the other station's call sign
  - d) Wait for the station to call "CQ" then answer it
19. What does the Q signal "QSL" mean when operating CW?
- a) We have already confirmed by card
  - b) I acknowledge receipt
  - c) We have worked before
  - d) Send slower
20. What is the first thing you should do if you are communicating with another amateur station and hear a station in distress break in?
- a) Continue your communication because you were on frequency first
  - b) Acknowledge the station in distress and determine what assistance may be needed
  - c) Change to a different frequency
  - d) Immediately cease all transmissions
21. How do you indicate you are looking for any station with which to make contact?
- a) CQ followed by your call sign
  - b) RST followed by your call sign
  - c) QST followed by your call sign

- d) SK followed by your call sign
22. What should you transmit when responding to a call of CQ?
- a) Your own CQ followed by the other station's call sign
  - b) Your call sign followed by the other station's call sign
  - c) The other station's call sign followed by your call sign
  - d) A signal report followed by your call sign
23. What must an amateur do when making a transmission to test equipment or antennas?
- a) Properly identify the station
  - b) Make test transmissions only after 10:00 PM local time
  - c) Notify the WPC of the test transmission
  - d) State the purpose of the test during the test procedure
24. What is the meaning of the procedural signal "CQ"?
- a) Call on the quarter hour
  - b) New antenna is being tested (no station should answer)
  - c) Only the called station should transmit
  - d) Calling any station
25. What brief statement is often used in place of "CQ" to indicate that you are listening for calls on a repeater?
- a) Say "Hello test" followed by your call sign
  - b) Say your call sign
  - c) Say the repeater call sign followed by your call sign
  - d) Say the letters "QSY" followed by your call sign
26. Why should you use the International Telecommunication Union (ITU) phonetic alphabet when identifying your station?
- a) The words are internationally recognized substitutes for letters
  - b) There is no advantage
  - c) The words have been chosen to represent amateur radio terms
  - d) It preserves traditions begun in the early days of amateur radio
27. Who is in charge of the repeater frequency band plan in your local area?
- a) The local WPC monitoring office
  - b) Only WPC HO New Delhi
  - c) The recognized frequency coordination body
  - d) Amateur Radio society of India
28. What is the main purpose of repeater coordination?
- a) To reduce interference and promote proper use of spectrum
  - b) To coordinate as many repeaters as possible in a small area
  - c) To coordinate all possible frequencies available for repeater use
  - d) To promote and encourage use of simplex frequencies
29. Which of these statements is true about legal power levels on the amateur bands?
- a) Always use the maximum power allowed to ensure that you complete the contact
  - b) An amateur may use no more than 200 Watts PEP to make an amateur contact
  - c) An amateur may use up to 1500 Watts PEP on any amateur frequency
  - d) An amateur must use the minimum transmitter power necessary to carry out the desired communication
30. What is the proper way to break into a conversation between two stations that are using the frequency?
- a) Say your call sign between their transmissions
  - b) Wait for them to finish and then call CQ
  - c) Say "Break-break" between their transmissions
  - d) Call one of the operators on the telephone to interrupt the conversation
31. Amateurs are forbidden to transmit about
- a) Equipments
  - b) weather
  - c) Antennas
  - d) Third party messages
32. Standard time and frequency is transmitted on
- a) 7050 KHz

- b) 14050 KHz
  - c) 21050 KHz
  - d) 10000 Khz
33. What is considered to be proper repeater operating practice?
- a) Monitor before transmitting and keep transmissions short
  - b) Identify legally
  - c) Use the minimum amount of transmitter power necessary
  - d) All of these answers are correct
34. What rule applies if two amateur stations want to use the same frequency?
- a) The station operator with a Restricted Grade license must yield the frequency to an General Grade licensee
  - b) The station operator with a lower power output must yield the frequency to the station with a higher power output
  - c) No frequency will be assigned for the exclusive use of any station and neither has priority
  - d) Station operators in ITU Regions 1 and 3 must yield the frequency to stations in ITU Region 2
35. What should you do if you hear a newly licensed operator that is having trouble with their station?
- a) Tell them to get off the air until they learn how operate properly
  - b) Report them to the WPC HO.
  - c) Contact them and offer to help with the problem
  - d) Move to another frequency
36. A3E indicates
- a) SSB
  - b) AM-DSB voice
  - c) FM Voice
  - d) FSK
37. Line of sight propagation is the mode of communication in
- a) LF
  - b) HF
  - c) MF
  - d) VHF
38. The wavelength of 300 MHz is in Meters is
- a) 1
  - b) .1
  - c) 1.1
  - d) 0.01
39. Squelch control is used to eliminate
- a) static interference
  - b) electrical disturbance
  - c) receiver noise
  - d) unwanted carrier
40. 4th harmonic of 2.5 MHz is
- a) 10 MHz
  - b) 15 MHz
  - c) 8 MHz
  - d) 7.5 MHz
- 41 The UHF range is
- a) 30 to 300 KHz
  - b) 300 to 3000 KHz
  - c) 3 to 30 GHz
  - d) 300 to 3000 MHz

42. Indian amateurs can communicate with other amateurs in
- All countries
  - Countries permitted by ITU
  - Countries permitted by Indian Government
  - Countries permitted by Indian Amateur society
43. Restricted grade amateurs can communicate on 7 MHz in
- A1
  - A3
  - F3
  - A3E
44. Lady amateurs are known as
- XL
  - XYL
  - YL
  - LY
45. Minimum age to become an amateur is
- 18 years
  - 14 years
  - 12 years
  - 16 years
46. All timing in the Log book should be in
- IST
  - UTC
  - GMT
  - Local time
47. Amateurs should preserve their log for a period of
- 6 months
  - 1 year
  - 2 years
  - 9 months from the date of the last entry
48. Q code to indicate time is
- QRG
  - QRX
  - QTR
  - QSA
49. Test signal shall not be continued more than
- 30 seconds
  - 1 minute
  - 2 minutes
  - 3 minutes
50. In India the standard time signal is broadcast by
- ISRO
  - WPC
  - OCS
  - NPL
51. PANPAN transmitted thrice indicates
- Distress
  - Emergency

- c) Urgency
  - d) Distress and emergency
52. The broadcast of music is allowed in amateur service
- a) on request
  - b) when channel is free
  - c) never
  - d) only for testing
53. The abbreviation VA means
- a) End of transmission
  - b) End of message
  - c) End of working
  - d) End of schedule
54. Swl's are permitted to transmit in the frequency band of
- a) 7-7.1 MHz
  - b) 3.89-3.9 MHz
  - c) 144-146 MHz
  - d) None of these
55. The amateur license is renewed by
- a) P & T
  - b) Ministry of communication
  - c) Monitoring stations
  - d) None of these
56. FM Broadcasting station emission is
- a) A1E
  - b) A3E
  - c) J3E
  - d) F3E
57. Q code to indicate the location of a station is
- a) QTL
  - b) QTH
  - c) QTN
  - d) None of these
58. Amateur station on a ship can contact another amateur on land on a frequency authorized to
- a) the ship
  - b) amateur stations
  - c) by the ministry of communication
  - d) ships calling frequency
59. SOS transmitted three times indicates
- a) urgency
  - b) distress
  - c) safety
  - d) none of these
60. All timings in logbook should be in
- a) IST
  - b) GMT
  - c) UTC
  - d) Local time

**ANSWER:-**

1.c, 2.a, 3.c, 4.b, 5.c, 6.b, 7.b, 8.b, 9.b, 10.d, 11.a, 12.d, 13.c, 14.c, 15.b, 16.c, 17.a, 18.b, 19.b, 20.b, 21.a, 22.c, 23.a, 24.d, 25.b, 26.a, 27.b, 28.b, 29.d, 30.c, 31.d, 32.d, 33.a, 34.c, 35.c, 36.b, 37.d, 38.a, 39.c, 40.a, 41.d, 42.a, 43.d, 44.c, 45.a, 46.a, 47.b, 48.c, 49.a, 50.d, 51.c, 52.c, 53.c, 54.d, 55.b, 56.d, 57.b, 58.b, 59.b, 60.a,

### **BASIC ELECTRONICS**

1. What is the name of a current that flows only in one direction?
  - a) An alternating current
  - b) A direct current
  - c) A normal current
  - d) A smooth current
2. What is the standard unit of frequency?
  - a) The megacycle
  - b) The Hertz
  - c) One thousand cycles per second
  - d) The electromagnetic force
3. How much voltage does an automobile battery usually supply?
  - a) About 12 volts
  - b) About 30 volts
  - c) About 120 volts
  - d) About 240 volts
4. What is the name of a current that reverses direction on a regular basis?
  - a) An alternating current
  - b) A direct current
  - c) A circular current
  - d) A vertical current
5. What is the term used to describe opposition to current flow in ordinary conductors such as wires?
  - a) Inductance
  - b) Resistance
  - c) Counter EMF
  - d) Magnetism
6. What instrument is used to measure the flow of current in an electrical circuit?
  - a) Frequency meter
  - b) SWR meter
  - c) Ammeter
  - d) Voltmeter
7. What instrument is used to measure Electromotive Force (EMF) between two points such as the poles of a battery?
  - a) Magnetometer
  - b) Voltmeter
  - c) Ammeter
  - d) Ohmmeter
8. What is the name for the distance a radio wave travels during one complete cycle?
  - a) Wave speed
  - b) Waveform
  - c) Wavelength
  - d) Wave spread
9. What term describes the number of times that an alternating current flows back and forth per second?
  - a) Pulse rate
  - b) Speed
  - c) Wavelength
  - d) Frequency
10. What does 50 hertz (Hz) mean?
  - a) 5000 cycles per second
  - b) 50 cycles per second
  - c) 5000 meters per second
  - d) 50 meters per second

11. Electromagnetic waves that oscillate more than 20,000 times per second as they travel through space are generally referred to as what?
  - a) Gravity waves
  - b) Sound waves
  - c) Radio waves
  - d) Gamma radiation
12. How fast does a radio wave travel through space?
  - a) At the speed of light
  - b) At the speed of sound
  - c) Its speed is inversely proportional to its wavelength
  - d) Its speed increases as the frequency increases
13. How does the wavelength of a radio wave relate to its frequency?
  - a) The wavelength gets longer as the frequency increases
  - b) The wavelength gets shorter as the frequency increases
  - c) There is no relationship between wavelength and frequency
  - d) The wavelength depends on the bandwidth of the signal
14. What is the formula for converting frequency to wavelength in meters?
  - a) Wavelength in meters equals frequency in Hertz multiplied by 300
  - b) Wavelength in meters equals frequency in Hertz divided by 300
  - c) Wavelength in meters equals frequency in megahertz divided by 300
  - d) Wavelength in meters equals 300 divided by frequency in megahertz
15. What are sound waves in the range between 300 and 3000 Hertz called?
  - a) Test signals
  - b) Ultrasonic waves
  - c) Voice frequencies
  - d) Radio frequencies
16. What property of a radio wave is often used to identify the different bands amateur radio operators use?
  - a) The physical length of the wave
  - b) The magnetic intensity of the wave
  - c) The time it takes for the wave to travel one mile
  - d) The voltage standing wave ratio of the wave
17. What is the frequency range of the 2 meter band in the India?
  - a) 144 to 146 MHz
  - b) 222 to 225 MHz
  - c) 434 to 438 MHz
  - d) 50 to 54 MHz
18. What is used to convert radio signals into sounds we can hear?
  - a) Transmitter
  - b) Receiver
  - c) Microphone
  - d) Antenna
19. What is used to convert sounds from our voice into radio signals?
  - a) Transmitter
  - b) Receiver
  - c) Speaker
  - d) Antenna
20. What two devices are combined into one unit in a transceiver?
  - a) Receiver, transmitter
  - b) Receiver, transformer
  - c) Receiver, transistor
  - d) Transmitter, deceiver
21. What device is used to convert the alternating current from a wall outlet into low-voltage direct current?
  - a) Inverter
  - b) Compressor
  - c) Power Supply

- d) Demodulator
22. What device is used to increase the output of a 10 watt radio to 100 watts?
- Amplifier
  - Power supply
  - Antenna
  - Attenuator
23. Which of the battery types listed below offers the longest life when used with a hand-held radio, assuming each battery is the same physical size?
- Lead-acid
  - Alkaline
  - Nickel-cadmium
  - Lithium-ion
24. What is the nominal voltage per cell of a fully charged nickel-cadmium battery?
- 1.0 volts
  - 1.2 volts
  - 1.5 volts
  - 2.2 volts
25. What battery type on this list is not designed to be re-charged?
- Nickel-cadmium
  - Carbon-zinc
  - Lead-acid
  - Lithium-ion
26. What is required to keep rechargeable batteries in good condition and ready for emergencies?
- They must be inspected for physical damage and replaced if necessary
  - They should be stored in a cool and dry location
  - They must be given a maintenance recharge at least every 6 months
  - All of these answers are correct
27. What is the best way to get the most amount of energy from a battery?
- Draw current from the battery as rapidly as possible
  - Draw current from the battery at the slowest rate needed
  - Reverse the leads when the battery reaches the 1/2 charge level
  - Charge the battery as frequently as possible
28. What formula is used to calculate current in a circuit?
- Current (I) equals voltage (E) multiplied by resistance (R)
  - Current (I) equals voltage (E) divided by resistance (R) [ $I=E/R$  Ohm's Law]
  - Current (I) equals voltage (E) added to resistance (R)
  - Current (I) equals voltage (E) minus resistance (R)
29. What formula is used to calculate voltage in a circuit?
- Voltage (E) equals current (I) multiplied by resistance (R) [ $E=I*R$  Ohm's Law]
  - Voltage (E) equals current (I) divided by resistance (R)
  - Voltage (E) equals current (I) added to resistance (R)
  - Voltage (E) equals current (I) minus resistance (R)
30. What formula is used to calculate resistance in a circuit?
- Resistance (R) equals voltage (E) multiplied by current (I)
  - Resistance (R) equals voltage (E) divided by current (I) [ $R=E/I$  Ohm's Law]
  - Resistance (R) equals voltage (E) added to current (I)
  - Resistance (R) equals voltage (E) minus current (I)
31. What is the resistance of a circuit when a current of 3 amperes flows through a resistor connected to 90 volts?
- 3 ohms
  - 30 ohms (As per ohm's law  $R=E/I$ , Thus  $R = 90 \text{ Volts} / 3 \text{ Ampere}$ )
  - 93 ohms
  - 270 ohms
32. What is the resistance in a circuit where the applied voltage is 12 volts and the current flow is 1.5 amperes?
- 18 ohms
  - 0.125 ohms

- c) 8 ohms
  - d) 13.5 ohms
33. What is the current flow in a circuit with an applied voltage of 120 volts and a resistance of 80 ohms?
- a) 9600 amperes
  - b) 200 amperes
  - c) 0.667 amperes
  - d) 1.5 amperes
34. What is the voltage across the resistor if a current of 0.5 amperes flows through a 2 ohm resistor?
- a) 1 volt
  - b) 0.25 volts
  - c) 2.5 volts
  - d) 1.5 volts
35. What is the voltage across the resistor if a current of 1 ampere flows through a 10 ohm resistor?
- a) 10 volts
  - b) 1 volt
  - c) 11 volts
  - d) 9 volts
36. What is the voltage across the resistor if a current of 2 amperes flows through a 10 ohm resistor?
- a) 20 volts
  - b) 0.2 volts
  - c) 12 volts
  - d) 8 volts
37. What is the current flowing through a 100 ohm resistor connected across 200 volts?
- a) 20,000 amperes
  - b) 0.5 amperes
  - c) 2 amperes
  - d) 100 amperes
38. What is the current flowing through a 24 ohm resistor connected across 240 volts?
- a) 24,000 amperes
  - b) 0.1 amperes
  - c) 10 amperes
  - d) 216 amperes
39. What is the formula used to calculate electrical power in a DC circuit?
- a) Power (P) equals voltage (E) multiplied by current (I)
  - b) Power (P) equals voltage (E) divided by current (I)
  - c) Power (P) equals voltage (E) minus current (I)
  - d) Power (P) equals voltage (E) plus current (I)
40. How much power is represented by a voltage of 13.8 volts DC and a current of 10 amperes?
- a) 138 watts
  - b) 0.7 watts
  - c) 23.8 watts
  - d) 3.8 watts
41. How much power is being used in a circuit when the voltage is 120 volts DC and the current is 2.5 amperes?
- a) 1440 watts
  - b) 300 watts
  - c) 48 watts
  - d) 30 watts
42. How can you determine how many watts are being drawn by your transceiver when you are transmitting?
- a) Measure the DC voltage and divide it by 60 Hz
  - b) Check the fuse in the power leads to see what size it is
  - c) Look in the Radio Amateur's Handbook
  - d) Measure the DC voltage at the transceiver and multiply by the current drawn when you transmit
43. How many amperes are flowing in a circuit when the applied voltage is 120 volts DC and the load is 1200 watts?
- a) 20 amperes
  - b) 10 amperes

- c) 120 amperes
  - d) 5 amperes
44. How many milliamperes is the same as 1.5 amperes?
- a) 15 milliamperes
  - b) 150 milliamperes
  - c) 1500 milliamperes
  - d) 15000 mill amperes
45. What is another way to specify the frequency of a radio signal that is oscillating at 1,500,000 Hertz?
- a) 1500 kHz
  - b) 1500 MHz
  - c) 15 GHz
  - d) 150 kHz
46. How many volts are equal to one kilovolt?
- a) One one-thousandth of a volt
  - b) one hundred volts
  - c) one thousand volts
  - d) one million volts
47. How many volts are equal to one microvolt?
- a) one one-millionth of a volt
  - b) one million volts
  - c) one thousand kilovolts
  - d) one one-thousandth of a volt
48. How many watts does a hand-held transceiver put out if the output power is 500 mill watts?
- a) 0.02 watts
  - b) 0.5 watts
  - c) 5 watts
  - d) 50 watts
49. What will happen to the resistance if the temperature of a carbon resistor is increased?
- a) It will increase by 20% for every 10 degrees centigrade
  - b) It will stay the same
  - c) It will change depending on the resistor's temperature coefficient rating
  - d) It will become time dependent
50. What type of capacitor is often used in power-supply circuits to filter the rectified AC?
- a) Disc ceramic
  - b) Vacuum variable
  - c) Mica
  - d) Electrolytic
51. Which of the following is the primary advantage of ceramic capacitors?
- a) Tight tolerance
  - b) High stability
  - c) High capacitance for given volume
  - d) Comparatively low cost
52. Which of the following is an advantage of an electrolytic capacitor?
- a) Tight tolerance
  - b) Non-polarized
  - c) High capacitance for given volume
  - d) Inexpensive RF capacitor
53. Which of the following is one effect of lead inductance in a capacitor used at VHF and above?
- a) Effective capacitance may be reduced
  - b) Voltage rating may be reduced
  - c) ESR may be reduced
  - d) The polarity of the capacitor might become reversed
54. What is the main disadvantage of using a conventional wire-wound resistor in a resonant circuit?
- a) The resistor's tolerance value would not be adequate for such a circuit
  - b) The resistor's inductance could detune the circuit

- c) The resistor could overheat
  - d) The resistor's internal capacitance would detune the circuit
55. What is an advantage of using a ferrite core with a toroidal inductor?
- a) Large values of inductance may be obtained
  - b) The magnetic properties of the core may be optimized for a specific range of frequencies
  - c) Most of the magnetic field is contained in the core
  - d) All of these choices are correct
56. How should two solenoid inductors be placed so as to minimize their mutual inductance?
- a) In line with their winding axis
  - b) With their winding axes parallel to each other
  - c) With their winding axes at right angles to each another
  - d) Within the same shielded enclosure
57. Why might it be important to minimize the mutual inductance between two inductors?
- a) To increase the energy transfer between both circuits
  - b) To reduce or eliminate unwanted coupling
  - c) To reduce conducted emissions
  - d) To increase the self-resonant frequency of both inductors
58. What is an effect of inter-turn capacitance in an inductor?
- a) The magnetic field may become inverted
  - b) The inductor may become self resonant at some frequencies
  - c) The permeability will increase
  - d) The voltage rating may be exceeded
59. What is the common name for a capacitor connected across a transformer secondary that is used to absorb transient voltage spikes?
- a) Clipper capacitor
  - b) Trimmer capacitor
  - c) Feedback capacitor
  - d) Suppressor capacitor
60. What is the common name for an inductor used to help smooth the DC output from the rectifier in a conventional power supply?
- a) Back EMF choke
  - b) Repulsion coil
  - c) Charging inductor
  - d) Filter choke
61. What type of component is a thermistor?
- a) A resistor that is resistant to changes in value with temperature variations
  - b) A device having a controlled change in resistance with temperature variations
  - c) A special type of transistor for use at very cold temperatures
  - d) A capacitor that changes value with temperature
62. What is the peak-inverse-voltage rating of a rectifier?
- a) The maximum voltage the rectifier will handle in the conducting direction
  - b) 1.4 times the AC frequency
  - c) The maximum voltage the rectifier will handle in the non-conducting direction
  - d) 2.8 times the AC frequency
63. What are the two major ratings that must not be exceeded for silicon-diode rectifiers?
- a) Peak inverse voltage; average forward current
  - b) Average power; average voltage
  - c) Capacitive reactance; avalanche voltage
  - d) Peak load impedance; peak voltage
64. What is the approximate junction threshold voltage of a germanium diode?
- a) 0.1 volt
  - b) 0.3 volts
  - c) 0.7 volts
  - d) 1.0 volts

65. When two or more diodes are connected in parallel to increase current handling capacity, what is the purpose of the resistor connected in series with each diode?
- The resistors ensure the thermal stability of the power supply
  - The resistors regulate the power supply output voltage
  - The resistors ensure that one diode doesn't carry most of the current
  - The resistors act as swamping resistors in the circuit
66. What is the approximate junction threshold voltage of a silicon diode?
- 0.1 volt
  - 0.3 volts
  - 0.7 volts
  - 1.0 volts
67. Which of the following is an advantage of using a Schottky diode in an RF switching circuit as compared to a standard silicon diode?
- Lower capacitance
  - Lower inductance
  - Longer switching times
  - Higher breakdown voltage
68. What are the stable operating points for a bipolar transistor that is used as a switch in a logic circuit?
- Its saturation and cut-off regions
  - Its active region (between the cut-off and saturation regions)
  - Between its peak and valley current points
  - Between its enhancement and deletion modes
69. Why is it often necessary to insulate the case of a large power transistor?
- To increase the beta of the transistor
  - To improve the power dissipation capability
  - To reduce stray capacitance
  - To avoid shorting the collector or drain voltage to ground
70. Which of the following describes the construction of a MOSFET?
- The gate is formed by a back-biased junction
  - The gate is separated from the channel with a thin insulating layer
  - The source is separated from the drain by a thin insulating later
  - The source is formed by depositing metal on silicon
71. Which element of a triode vacuum tube is used to regulate the flow of electrons between cathode and plate?
- Control grid
  - Heater
  - Screen Grid
  - Suppressor grid
72. Which of the following solid state devices is most like a vacuum tube in its general characteristics?
- A bipolar transistor
  - An FET
  - A Tunnel diode
  - A varistor
73. What is the primary purpose of a screen grid in a vacuum tube?
- To reduce grid-to-plate capacitance
  - To increase efficiency
  - To increase the high frequency response
  - To decrease plate resistance
74. What is an advantage of the low internal resistance of Nickel Cadmium batteries?
- Long life
  - High discharge current
  - High voltage
  - Rapid recharge
75. What is the minimum allowable discharge voltage for maximum life of a standard 12 volt lead acid battery?
- 6 volts
  - 8.5 volts

- c) 10.5 volts
  - d) 12 volts
76. When is it acceptable to recharge a carbon-zinc primary cell?
- a) As long as the voltage has not been allowed to drop below 1.0 volt
  - b) When the cell is kept warm during the recharging period
  - c) When a constant current charger is used
  - d) Never
77. Which of the following is a rechargeable battery?
- a) Carbon-zinc
  - b) Silver oxide
  - c) Nickel Metal Hydride
  - d) Mercury
78. What is impedance?
- a) The electric charge stored by a capacitor
  - b) The inverse of resistance
  - c) The opposition to the flow of current in an AC circuit
  - d) The force of repulsion between two similar electric fields
79. What is reactance?
- a) Opposition to the flow of direct current caused by resistance
  - b) Opposition to the flow of alternating current caused by capacitance or inductance
  - c) A property of ideal resistors in AC circuits
  - d) A large spark produced at switch contacts when an inductor is de-energized
80. Which of the following causes opposition to the flow of alternating current in an inductor?
- a) Conductance
  - b) Reluctance
  - c) Admittance
  - d) Reactance
81. Which of the following causes opposition to the flow of alternating current in a capacitor?
- a) Conductance
  - b) Reluctance
  - c) Reactance
  - d) Admittance
82. How does a coil react to AC?
- a) As the frequency of the applied AC increases, the reactance decreases
  - b) As the amplitude of the applied AC increases, the reactance increases
  - c) As the amplitude of the applied AC increases, the reactance decreases
  - d) As the frequency of the applied AC increases, the reactance increases
83. How does a capacitor react to AC?
- a) As the frequency of the applied AC increases, the reactance decreases
  - b) As the frequency of the applied AC increases, the reactance increases
  - c) As the amplitude of the applied AC increases, the reactance increases
  - d) As the amplitude of the applied AC increases, the reactance decreases
84. What happens when the impedance of an electrical load is equal to the internal impedance of the power source?
- a) The source delivers minimum power to the load
  - b) The electrical load is shorted
  - c) No current can flow through the circuit
  - d) The source can deliver maximum power to the load
85. Why is impedance matching important?
- a) So the source can deliver maximum power to the load
  - b) So the load will draw minimum power from the source
  - c) To ensure that there is less resistance than reactance in the circuit
  - d) To ensure that the resistance and reactance in the circuit are equal
86. What unit is used to measure reactance?
- a) Farad
  - b) Ohm

- c) Ampere
  - d) Siemens
87. What unit is used to measure impedance?
- a) Volt
  - b) Ohm
  - c) Ampere
  - d) Watt
88. Why should core saturation of a conventional impedance matching transformer be avoided?
- a) Harmonics and distortion could result
  - b) Magnetic flux would increase with frequency
  - c) RF susceptance would increase
  - d) Temporary changes of the core permeability could result
89. What is one reason to use an impedance matching transformer?
- a) To reduce power dissipation in the transmitter
  - b) To maximize the transfer of power
  - c) To minimize SWR at the antenna
  - d) To minimize SWR in the transmission line
90. Which of the following devices can be used for impedance matching at radio frequencies?
- a) A transformer
  - b) A Pi-network
  - c) A length of transmission line
  - d) All of these choices are correct
91. Which of the following describes one method of impedance matching between two AC circuits?
- a) Insert an LC network between the two circuits
  - b) Reduce the power output of the first circuit
  - c) Increase the power output of the first circuit
  - d) Insert a circulator between the two circuits
92. A two-times increase or decrease in power results in a change of how many dB?
- a) 2 dB
  - b) 3 dB
  - c) 6 dB
  - d) 12 dB
93. How does the total current relate to the individual currents in each branch of a parallel circuit?
- a) It equals the average of each branch current
  - b) It decreases as more parallel branches are added to the circuit
  - c) It equals the sum of the currents through each branch (Kirchhoff's Current Law)
  - d) It is the sum of the reciprocal of each individual voltage drop
94. Capacitance is measured in
- a) Amperes
  - b) watt
  - c) Farad
  - d) Coulombs
95. Frequency is
- a) cycles per second
  - b) Kilo cycles per second
  - c) Cycles per minute
  - d) cycles per hour
96. Resonant frequency in a tuned circuit is equal to
- a)  $1/2\pi LC$
  - b)  $1/2\pi\sqrt{LC}$
  - c)  $2\pi\sqrt{LC}$
  - d)  $2\pi\sqrt{L+C}$
97. Power dissipated in a 400 Ohm resistor at 1 Amp is

- a) 40 Watts
  - b) 400 KW
  - c) 4 Watts
  - d) 400 Watts
98. Zener diode is used for
- a) Rectification
  - b) Voltage regulation
  - c) Current regulation
  - d) Switching
99. Plate current in a diode flows only when the plate is
- a) Negative with respect to cathode
  - b) positive with respect to cathode
  - c) when plate is at a lower voltage than cathode
  - d) both at same potential
100. 3 resistors of 2,3 & 4 ohms are connected in series. The voltage across the circuit is 9 V , the current drawn by 3 ohms resistor is
- a) 1.5 Amps
  - b) 27 Amps
  - c) 1 Amp
  - d) 3 Amps
101. A superhetrodyne receiver is tuned to 555 KHz and its local oscillator at 1010 KHz . The image frequency will be
- a) 1565 KHz
  - b) 455 KHz
  - c) 1465 KHz
  - d) none of these
102. 3 to 30 MHz band is known as
- a) MF
  - b) LF
  - c) VHF
  - d) HF
103. The wavelength of a broadcast station at 1000 KHz is
- a) 30 Meters
  - b) 300 Meters
  - c) 0.3 Meteors
  - d) none of these
104. The core of power supply transformer is laminated to
- a) decrease impedance
  - b) increase impedance
  - c) decrease eddy current losses
  - d) none of these
105. In a resonant circuit
- a)  $X_L = X_C$
  - b)  $X_L > X_C$
  - c)  $X_L < X_C$
  - d) none of these
106. When frequency of a carrier is varied according to modulation the result is
- a) frequency modulation
  - b) amplitude modulation

- c) product detection
  - d) none of these
107. The phase relationship between the input and output of a common emitter circuit in degrees is
- a) 90
  - b) 180
  - c) 270
  - d) 0
108. The quartz crystal oscillator is known for its
- a) linearity
  - b) stability
  - c) high output
  - d) flexibility
109. The effect of inter electrode capacitance of a triode is more predominant at
- a) HF
  - b) VHF
  - c) LF
  - d) none of these
110. Which of the following is a characteristic of a liquid crystal display?
- a) It requires ambient or back lighting
  - b) It offers a wide dynamic range
  - c) It has a wide viewing angle
  - d) All of these choices are correct
111. What is meant by the term MMIC?
- a) Multi Megabyte Integrated Circuit
  - b) Monolithic Microwave Integrated Circuit
  - c) Military-specification Manufactured Integrated Circuit
  - d) Mode Modulated Integrated Circuit
112. What is a microprocessor?
- a) A low powered analog signal processor used as a microwave detector
  - b) A miniature computer on a single integrated circuit chip
  - c) A microwave detector, amplifier, and local oscillator on a chip
  - d) A low voltage amplifier used in a microwave transmitter modulator stage
113. What safety feature does a power-supply bleeder resistor provide?
- a) It acts as a fuse for excess voltage
  - b) It discharges the filter capacitors
  - c) It removes shock hazards from the induction coils
  - d) It eliminates ground-loop current
114. What components are used in a power-supply filter network?
- a) Diodes
  - b) Transformers and transistors
  - c) Quartz crystals
  - d) Capacitors and inductors
115. What should be the minimum peak-inverse-voltage rating of the rectifier in a full-wave power supply?
- a) One-quarter the normal output voltage of the power supply
  - b) Half the normal output voltage of the power supply
  - c) Double the normal peak output voltage of the power supply
  - d) Equal to the normal output voltage of the power supply

116. What should be the approximate minimum peak-inverse-voltage rating of the rectifier in a half-wave power supply?
- One-half the normal peak output voltage of the power supply
  - Half the normal output voltage of the power supply
  - Equal to the normal output voltage of the power supply
  - Two times the normal peak output voltage of the power supply
117. What should be the impedance of a low-pass filter as compared to the impedance of the transmission line into which it is inserted?
- Substantially higher
  - About the same
  - Substantially lower
  - Twice the transmission line impedance
118. What is an advantage of a crystal controlled transmitter?
- Stable output frequency
  - Excellent modulation clarity
  - Ease of switching between bands
  - Ease of changing frequency
119. What type of receiver is suitable for CW and SSB reception but does not require a mixer stage or an IF amplifier?
- A super-regenerative receiver
  - A TRF receiver
  - A super-heterodyne receiver
  - A direct conversion receiver
120. What type of circuit is used in many FM receivers to convert signals coming from the IF amplifier to audio?
- Product detector
  - Phase inverter
  - Mixer
  - Discriminator
121. What portion of the AC cycle is converted to DC by a half-wave rectifier?
- 90 degrees
  - 180 degrees
  - 270 degrees
  - 360 degrees
122. What portion of the AC cycle is converted to DC by a full-wave rectifier?
- 90 degrees
  - 180 degrees
  - 270 degrees
  - 360 degrees
123. What is the output waveform of an unfiltered full-wave rectifier connected to a resistive load?
- A series of DC pulses at twice the frequency of the AC input
  - A series of DC pulses at the same frequency as the AC input
  - A sine wave at half the frequency of the AC input
  - A steady DC voltage
124. Which of the following is a characteristic of a Class A amplifier?
- Low standby power
  - High Efficiency
  - No need for bias
  - Low distortion
125. For which of the following modes is a Class C power stage appropriate for amplifying a modulated signal?

- a) SSB
  - b) CW
  - c) AM
  - d) All of these answers are correct
126. Which of the following is an advantage of a Class C amplifier?
- a) High efficiency
  - b) Linear operation
  - c) No need for tuned circuits
  - d) All of these answers are correct
127. How is the efficiency of an RF power amplifier determined?
- a) Divide the DC input power by the DC output power
  - b) Divide the RF output power by the DC input power
  - c) Multiply the RF input power by the reciprocal of the RF output power
  - d) Add the RF input power to the DC output power
128. Which of the following describes a linear amplifier?
- a) Any RF power amplifier used in conjunction with an amateur transceiver
  - b) An amplifier whose output preserves the input waveform
  - c) A Class C high efficiency amplifier
  - d) An amplifier used as a frequency multiplier

**ANSWER:-**

1.c, 2.b, 3.a, 4.b, 5.b, 6.c, 7.b, 8.c, 9.d, 10.b, 11.c, 12.a, 13.b, 14.d, 15.c, 16.a, 17.a, 18.b, 19.a, 20.a, 21.c, 22.a, 23.d, 24.b, 25.b, 26.d, 27.b, 28.b, 29.a, 30.b, 31.b, 32.c, 33.d, 34.a, 35.a, 36.a, 37.c, 38.c, 39.a, 40.a, 41.b, 42.d, 43.b, 44.c, 45.a, 46.c, 47.a, 48.b, 49.c, 50.d, 51.d, 52.c, 53.a, 54.b, 55.d, 56.c, 57.b, 58.b, 59.d, 60.d, 61.b, 62.c, 63.a, 64.b, 65.c, 66.c, 67.a, 68.a, 69.d, 70.b, 71.a, 72.b, 73.a, 74.b, 75.c, 76.d, 77.c, 78.c, 79.b, 80.d, 81.c, 82.d, 83.a, 84.d, 85.a, 86.b, 87.b, 88.a, 89.b, 90.d, 91.a, 92.b, 93.c, 94.c, 95.a, 96.b, 97.d, 98.b, 99.d, 100.c, 101.a, 102.d, 103.b, 104.c, 105.a, 106.a, 107.d, 108.b, 109.d, 110.d, 111.b, 112.b, 113.b, 114.d, 115.c, 116.d, 117.b, 118.a, 119.d, 120.d, 121.b, 122.d, 123.a, 124.d, 125.b, 126.a, 127.b, 128.b.

## **SAMPLE ASOC EXAM QUESTION PAPER**

**Time for General Grade : 2 hours**

**Time for Restricted Grade : 1 hour**

**Max marks for both grades : 100**

### **Instructions**

1. There will be 2 sections in the question paper. Each section contains 50 questions. All questions carry equal marks. All the candidates are required to write the answers for the questions in the box provided for each of the respective questions.
2. Candidates appearing for General grade should answer all the questions.
3. Candidates appearing for Restricted grade should answer only first 25 questions from each of the section.

### **SECTION-A**

**1) Parameter that determines lowest signal reception capability of a receiver is**

- a) Sensitivity
- b) Fidelity c)
- Selectivity d)
- Squelch

**2) TRF stands for**

- a) Turning radio frequency
- b) Turning rod frequency
- c) Tuned radio feed
- d) Tuned radio frequency

**3) If a super hetero dyne radio receiver is tuned to 1255 KHz & the IF frequency is 455KHz, then the frequency of the local oscillator of the receiver is**

- a) 1255 KHz
- b) 800 KHz
- c) 1710 KHz
- d) 455 KHz

**4) Kirchhoff's voltage Law states that**

- a) The sum of voltages in a loop is zero
- b) The algebraic sum of voltages in a loop is zero
- c) The sum of currents at a junction is zero
- d) The algebraic sum of currents at a junction is zero

**5) Among all these materials, which one has poor conductivity**

- ? a) Copper
- b) Aluminum
- c) Silicon d)
- Silver

**6) A magnet does not attract which one in the following**

- a) Nickel
- b) Aluminum
- c) Iron
- d) Cobalt

**7) The unit of resistance is**

- a) Mho
- b) Volts
- c) Ampere
- d) Ohm

**8) The expanded form for 'LDR' is**

- a) Light Emitting Display
- b) Low Dependent Reading
- c) Light Emitting Diode
- d) Light Dependent Resistor

**9) The three leads of a common transistor are**

- a) Base Collector Case
- b) Emitter Collector Bias
- c) Collector Base Omitter
- d) Collector Base Emitter

**10) If R is resistance, I is current and V is voltage, then Ohms law states that**

- a)  $R=V/I$
- b)  $I=R/V$
- c)  $V=R/I$
- d)  $V/(R/I)=1$

**11) If two capacitors are placed in series, is the final capacitance will be:**

- a) Higher than the sum of the two capacitors
- b) Lower than the least of the two capacitors
- c) The sum of the two capacitors
- d) Cannot be determined the given data.

**12) Which is the unit of energy in electronics?**

- a) Ohm
- b) Ampere
- c) Joules
- d) Watt

**13) The high frequency band (HF) is**

- a) 3KHz to 30KHz
- b) 3MHz to 30MHz
- c) 30KHz to 300KHz
- d) 30MHz to 300MHz

**14) Among the following which is not a directional antenna**

- a) Whip antenna
- b) Yagi-Uda antenna
- c) Loop antenna
- d) Dish antenna

**15) The unit of current**

- is a) Volts  
b) Ampere  
c) Watt d)  
Hertz

**16) If a small value of inductance is connected in parallel with a large value, the combined inductance will be**

- a) The same
- b) Higher c)  
Lower
- d) Cannot be determined with the given data.

**17) The equivalent capacitance when three capacitors of 150 micro farad are connected in series is**

- a) 450 micro farad capacitor
- b) 300 micro farad capacitor
- c) 150 micro farad capacitor
- d) 50 micro farad capacitor

**18) A resistor with color bands: Red-Violet-Orange-Silver, has the value of**

- a) 23 kilo Ohm , 5% tolerance
- b) 27 kilo Ohm , 5% tolerance
- c) 2.7 kilo Ohm , 10% tolerance
- d) 27 kilo Ohm , 10% tolerance

**19) The abbreviation of RMS voltage is**

- a) Railway Mail Service voltage
- b) Real Mean Square voltage c)  
Root Mean Square voltage d)  
Root Mean Service voltage

**20) If the peak voltage of a sinusoidal ac supply is 150 volts, the RMS value is**

- a) Less than peak value
- b) More than peak value
- c) Equal to peak value
- d) Not related to peak value of the voltage

**21) A capacitor and inductor in series is called a**

- a) Tuned Circuit
- b) Timing Circuit
- c) Delay Circuit
- d) Schmitt Circuit

**22) A domestic inverter**

- a) Converts ac to ac
- b) Converts ac to dc
- c) Converts dc to ac
- d) Converts dc to dc

**23) The current in a circuit is 25mA, then the equivalent value is**

- a) 0.00025 Ampere
- b) 0.0025 Ampere
- c) 0.025 Ampere
- d) 0.25 Ampere

**24) If 2 mA current flows through a 100 Kohm resistor, then the voltage across it is**

- a) 2 volts
- b) 20 volts
- c) 200 volts
- d) 0.2 volts

**25) The tolerance bands with colors gold, silver & brown**

- represent**
- a) 5%, 10%, 2%
  - b) 5%, 10%, 1%
  - c) 10%, 5%, 1%
  - d) 10%, 5%, 2%

**26) India uses which encoding technique for commercial TV broad cast**

- a) NTSC
- b) SECAM
- c) PAL
- d) None of the above

**27) The video bandwidth in a TV transmission in India is**

- a) 455 KHz
- b) 10.7 MHz
- c) 4.2 MHz
- d) 5.5 MHz

**28) Sky wave propagation**

utilizes a) Troposphere

b) Stratosphere

c) Ionosphere

d) Exosphere

**29) Ionosphere does not have \_\_\_\_\_**

layer. a) C

b) D

c) E

d) F

**30) Which layer of ionosphere disappears during night**

time? a) C

b) D

c) E

d) F

**31) In dealing with sky/ground wave propagation, the area of silence where no signals are received is the**

a) dead zone b)

skip distance c)

skip zone

d) propagation distance.

**32) Frequencies lesser than the critical frequency are**

a) passed into space

b) the most desirable

c) returned to earth

d) refracted by the F2 layer

**33) For mobile communications, the up-link frequency is \_\_\_\_\_ down link frequency .**

a) Less than

b) More than

c) Equal to

d) Less or more than the

**34) All India Radio (AIR) does not broadcast**

a) Amplitude Modulation transmission

b) Frequency Modulation transmission

c) Pulse Modulation transmission

d) Both a and b

**35) A diode can be used in the following stages of a radio receiver** a) Detector  
b) Mixer  
c) Rectification  
d) All of the above

**36) Geo stationary orbit is \_\_\_\_ km away from the earth**  
a) 3100  
b) 32786  
c) 36786  
d) 39000

**37) Which antenna is used for direction finding purpose?** a) Loop antenna  
b) Active Whip antenna  
c) Whip antenna  
d) Dipole antenna

**38) A transformer converts**  
a) AC voltage into DC voltage  
b) DC voltage into AC voltage  
c) AC voltage into different AC voltage  
d) DC voltage into different DC voltage

**39) A matching transformer (10:1 turns ratio) is used to match 200 ohms into \_\_\_\_ ohms.**  
a) 2  
b) 20  
c) 200  
d) 5

**40) The following are transformer losses** a) Hysteresis losses  
b) Eddy current losses  
c) Copper losses  
d) All of the above

**41) Digital modulation techniques are**  
a) Amplitude modulation  
b) Frequency modulation  
c) Phase shift keying

d) Phase modulation

**42) The following idle component dissipates energy**

- a) Capacitor
- b) Inductor
- c) Resistor
- d) All of the above

**43) The most common stage used for amplifying an electrical signal is**

- a) Common Base
- b) Common collector
- c) Common emitter
- d) Emitter follower

**44) The biasing of a transistor is to**

- a) To avoid thermal run away
- b) To provide stable operation
- c) To have a stable quiescent point
- d) All of the above

**45) The ideal value of ripple factor should**

- be a) 0
- b) 1
- c) 0.707
- d) 1.414

**46) The full wave rectifier employs**

- a) 1 diode
- b) 2 diodes
- c) 3 diodes     d) 4 diodes

**47) The following is used as a Voltage smoothing device**

- a) Resistor
- b) Capacitor c)
- Inductor d)
- Both a and b

**48) The following modulation is used for audio transmission in TV broadcast**

- a) Amplitude modulation
- b) Frequency modulation
- c) Pulse modulation
- d) None of the above

**49) NICAM technique is used in TV broadcast**

- a) For transmitting video
- b) For transmitting mono aural audio
- c) For transmitting stereo audio
- d) For transmitting timing signals

**50) Conventional Facsimile machine sends \_\_\_\_\_ data over \_\_\_\_\_**

- media**
- a) Analog, air
  - b) Digital, air
  - c) Analog, telephone
  - d) Digital, telephone

### **SECTION-B**

**51) Under Indian Wireless Telegraph rules, 1973, the minimum age to work on a radio transmitting apparatus is \_\_\_\_\_ years**

- a) 12
- b) 15
- c) 18
- d) 21

**52) An amateur is forbidden to transmit**

- a) communications of business
- b) transmissions of entertainment value or music
- c) advertisements
- d) all the above

**53) Log containing chronological record of all transmissions should be preserved for**

- a) 1 day
- b) 1 month
- c) 6 months
- d) 12 months

**54) Log containing chronological record of all transmissions should contain**

- a) Date and time of all transmissions
- b) Call signs intercepted
- c) Summary of communications
- d) All of the above

**55) Which of the following should be given top priority?**

- a) Safety signal
- b) Routine communication signal
- c) Distress signal
- d) Urgency signal

**56) The following is not an amateur call sign of India**

- a) VU2XYZ
- b) VU3ABC
- c) VU44AB
- d) VU3RS

**57) The standard time & frequency signal in India**

- is
- a) 5 MHz
  - b) 10 MHz
  - c) 20 MHz
  - d) 100 MHz

**58) The standard time & frequency signal in India call sign**

- is
- a) VU2
  - b) VU3
  - c) ATA
  - d) ATU

**59) The abbreviation for end of message in Morse code is**

- a) AA
- b) AR
- c) ED
- d) EN

**60) QTR stands for ?**

- a) What is the correct time?
- b) What is your position in latitude and longitude?
- c) Thank you for sending
- d) What is Time and Hour?

**61) The standard emission designation consists**

- of
- a) 8 letters/numerals
  - b) 3 letters/numerals
  - c) 6 letters/numerals

d) 2 letters/numerals

**62) Metric waves means**

- a) 3-30 MHz
- b) 3-30 KHz c)
- 30-300 KHz d)
- 30-300 MHz

**63) The standard bandwidth designation consists of**

- a) 5 letters/numerals
- b) 3 letters/numerals
- c) 4 letters/numerals
- d) 2 letters/numerals

**64) Which should be used as a suffix in call sign for mobile amateur stations**

- a) ME
- b) MB
- c) MO
- d) ML

**65) The Q code for “What is the correct time” is**

- a) QCT
- b) QTM
- c) QRT
- d) QTR

**66) The Q code for “ Are my signals fading? ” is**

- a) QSB
- b) QAM
- c) QSI
- d) QSF

**67) The Q code QRQ represents**

- a) Shall I stop slowing?
- b) Shall I increase power?
- c) Shall I send faster?
- d) Shall I decrease power?

**68) The Phonetic alphabet for**

- L is** a) Lilly
- b) Lima
- c) Limca
- d) Lisa

**69) The Phonetic for '3' is**

- a) Terra Three
- b) Tele Three
- c) Tango Three
- d) Tango Tree

**70) The expanded form for AA in Morse code**

- is
- a) End of line
  - b) End of message
  - c) End of transmission
  - d) End of signal

**11) The expanded form for TU in Morse code is**

- a) Thank u
- b) Thank you
- c) Thank everyone
- d) None of the above

**72) The expanded form for CQ in Morse code is**

- a) Calling you
- b) Calling any station
- c) Calling Quebec
- d) Calling none

**73) The abbreviation for 'stand by' in Morse code**

- is
- a) SY
  - b) AS
  - c) SB
  - d) AD

**74) The Q code for "What is the name of your station ?"**

- is
- a) QNS
  - b) QRA
  - c) QYS
  - d) QNA

**75) The Q code for "Are you ready?" is**

- a) QRY
- b) QRV
- c) QAR
- d) QRE

**76) The expanded form of SOS**

- is a) Save our selves
- b) Save one self
- c) Save one souls
- d) Save our souls

**77) The distress signal in radio telephony**

- is a) Help, Help, Help
- b) May day. May day, May day
- c) Save, Save, Save
- d) Save our souls

**78) The phonetic for alphabet 'Y' is**

- a) Yardly
- b) Yankee
- c) Yan
- d) Yarn

**79) The phonetic for '9' is**

- a) New Nine
- b) Nove Nine
- c) Novel Nine
- d) Nine

**80) Which one of this is not a standard frequency**

- signal
- a) 15 MHz
  - b) 10 MHz
  - c) 5 MHz
  - d) 1 MHz

**81) The renewal fee for General Grade Amateur license under new rules**

- is
- a) Rs 1000
  - b) Rs 2000
  - c) Rs. 100
  - d) Rs.200

**82) The fee for mobile endorsement under new rules is**

- a) Rs 100
- b) Rs. 200
- c) Rs. 1000
- d) Rs. 2000

**83) The maximum DC power permitted under new rules for Restricted grade amateurs under 144-146 MHz band is**

- a) 10 watts
- b) 25 watts
- c) 50 watts
- d) 100 watts

**84) The maximum DC power permitted under new rules for General grade amateurs under 7000-7100 KHz band is**

- a) 50 watts
- b) 100 watts
- c) 200 watts
- d) 400 watts

**85) The permitted emission under new rules for Restricted grade amateurs under 144-146 MHz band is**

- a) A3E
- b) J3E
- c) F3E
- d) A1A

**86) The first symbol in the designation for classification of emission represents**

- a) Nature of signals modulating the main carrier
- b) Type of modulation of the main carrier
- c) Type of information to be transmitted
- d) None of the above

**87) Emission designation of commercial FM broadcast transmission in India is**

- a) ME
- b) J3E
- c) F3E
- d) R3E

**88) Conventional Morse code transmission can be represented by**

- a) J3E
- b) F3E
- c) ME
- d) A1A

**89) The second symbol in the designation of emission represents**

- a) Nature of signals modulating the main carrier
- b) Type of modulation of the main carrier
- c) Type of information to be transmitted
- d) None of the above

**90) The following frequency band is permitted for general grade amateurs only**

- a) 1820 - 1860 KHz
- b) 3500 - 3700 KHz
- c) 5725 - 5840 MHz
- d) 21000 - 21450 KHz

**91) The fee for change of location new rules is**

- a) Rs. 100
- b) Rs. 200
- c) Rs. 500
- d) Rs. 1000

**92) The maximum DC power permitted under new rules for General grade amateurs under 144-146 MHz band is**

- a) 10 watts
- b) 25 watts
- c) 50 watts
- d) 100 watts

**93) The standard designation for a bandwidth of 4.8 KHz is**

- a) 4800 Hz
- b) 4K8
- c) 4K80
- d) 4800

**94) A bandwidth of 402 M represents**

- a) 4000 MHz
- b) 402 MHz
- c) 4.2 MHz
- d) 420 MHz

**95) The emission C3F denotes**

- a) Single side band analog audio emission
- b) Common analog radio emission
- c) Vestigial sideband analog TV emission

d) Vestigial sideband digital TV emission

**96) The expanded form for RST**

- is a) Readability signal tone  
b) Readability strength tone c)  
Readability strength testing  
d) Readability signal strength tone

**97) The phonetic for 'W' is**

- a) Wine  
b) White  
c) Whiskey  
d) Wheel

**98) The UHF band extends**

- from** a) 3-30 KHz  
b) 30-300 MHz  
c) 3-30 MHz  
d) 300-3000 MHz

**99) Which of the frequency bands was not allocated for Amateur service**

- a) 7000 - 7100 KHz  
b) 7100 - 7200 KHz c)  
10120 - 10240 KHz d)  
28000 - 29700 KHz

**100) 'WPC' stands for**

- a) Wireless Planning and Coordination  
b) Wireless Placement cell  
c) Wireless Planning cell  
d) Wireless Placement and Coordination

\*\*\*\*\* \*\* \* \* \* \*\* \* \*\* \* \*\* \*\*

## Annexure-I

### List of Wireless Monitoring Stations conducting amateur radio licencing examination

**Ahmedabad:**

Officer-in-Charge,  
Wireless Monitoring Station,  
A/101, Amarkunj Appartments,  
Opp. Gurukul,  
Ahmedabad-380052

**Ajmer:**

Officer-in-Charge,  
Wireless Monitoring Station,  
Christianganj, Shantipura,  
Ajmer-305 001

**Bangalore:**

Officer-in-Charge,  
Wireless Monitoring Station, 18,  
Padmanabha Nagar,  
Banashakari, 2nd Stage, Bangalore-  
560070

**Bhopal:**

Officer-in-Charge,  
Wireless Monitoring Station,  
E-1/149,  
Arera Colony,  
Bhopal-462003

**Calcutta:**

Officer-in-Charge,  
Wireless Monitoring Station,  
Village-Gopalpur, P.O. Sarkarpool,  
24-Parganas,  
Calcutta- 743352

**Darjeeling:**

Officer-in-Charge,  
Wireless Monitoring Station, 7,  
Oak's Rose Bank Building,  
Holding No. 560,  
Darjeeling 734101

**Dibrugarh:**

Officer-in-Charge,  
Wireless Monitoring Station,  
Girdharilal Sardarmall's Building,  
Mancotta Road,  
Dibrugarh-786001

**Delhi:**

Engineer-in-Charge,  
Regional Headquarter (N),  
E-315, Pushpa Bhavan, Madangir  
Road,  
New Delhi-110 062

**Gorakhpur:**

Officer-in-Charge,  
Wireless Monitoring Station, Avas  
Vikas Colony, Surajkund,  
Gorakhpur-273001

**Goa:**

Officer-in-Charge,  
Wireless Monitoring Station, Near  
Teachers' Training College, P.O.  
Alto Betim,  
Goa- 403112

**Hyderabad:**

Officer-in-Charge,  
Wireless Monitoring Station, 1-1-  
648/4  
Gandhi Nagar,  
Secunderabad-500380

**Jalandher City:**

Officer-in-Charge,  
Wireless Monitoring Station, 327,  
Mota Singh Nagar, Jullander City  
144001

**Jalna:**

Engineer-in-Charge  
International Satellite Monitoring  
Earth Station, Indewadi Village,  
Ambad Road,  
Jalna-431203

**Madras:**

Officer-in-Charge,  
Wireless Monitoring Station,  
Perungudi,  
Madras-600096

**Mangalore:**

Officer-in-Charge,  
Wireless Monitoring Station, 3-1-41,  
Bijai,  
Swarna Niketan,  
Mangalore-575004

**Mumbai:**

Officer-in-Charge,  
Wireless Monitoring Station, Gorai  
Road, Borivili (W),  
Mumbai 400092

**Nagpur:**

Officer-in-Charge,  
Wireless Monitoring Station,  
Chindwara Road, P.O. Koradi T.P.S.,  
Nagpur 441111

**Ranchi:**

Officer-in-Charge,  
Wireless Monitoring Station, P.O.  
Harmo Housing Colony,  
Ranchi-834012

**Shillong:**

Engineer Inspection,  
Wireless Monitoring Station,  
Lapalang, Rynjah,  
Shillong-793006

**Srinagar:**

Officer-in-Charge,  
Wireless Monitoring Station, Kursu,  
Rajbagh,  
Srinagar-190008

**Trivandrum:**

Officer-in-Charge,  
Wireless Monitoring Station,  
T.C. 9/951-1, Panicker's Lane,  
Sasthamangalam,  
Trivandrum- 695010

Schedule of licencing examination:	
Place	Month of Examination
Delhi, Mumbai, Calcutta & Madras Ahmedabad, Hyderabad & Nagpur	Every month January, March, June, August, October & December
Ajmer, Bangalore, Bhopal, Darjeeling, Dibrugarh, Gorakhpur, Goa, Jalandhar, Jalna, Mangalore, Ranchi, Shillong, Srinagar, Trivandrum, Visakhapatnam	January, April, July & October

**Visakhapatnam:**

Officer-in-Charge,  
Wireless Monitoring Station,  
6-20-9,  
Chinna Waltair,  
Visakhapatnam- 530023

Annexure-II  
 Call-sign Prefixes of Amateur Radio Stations of different  
 countries allotted by the  
 International Telecommunication Union (ITU)

<b>Prefix</b>	<b>Country</b>	<b>CQ Zone</b>
1AO	Sovereign Military Order of Malta	15
1S	Spratly Is.	36
1X	Chechnya (erstwhile USSR)	
2A-2Z	United Kingdom	14
3A	Monaco	14
3B6,7	Agalega & St. Brandon	39
3B8	Mauritius	39
3B9	Rodriguez Is.	39
3C	Equatorial Guinea	36
3C0	Annobon	36
3D2	Fiji, Conway Reef, Rotuma Is.	32
3DA	Swaziland	38
3DN	Fiji	32
3K3	European Islands between 30 Deg. E long. To 170 Deg. W long	
3V	Tunisia	33
3W, XV	Vietnam	26
3X	Guinea	35
3Y	Bouvet	38
3Y	Peter Is.	12
3Z	Poland	15
4F	Philippines	27
4JA-4JZ, 4KA-4KZ	Azerbaijan	21
4J1, R1MV	Malyj Vysotskij Island	16
4K0	Drifting Ice Station (Russian Polar Stations)	
4K1	Antarctica (Russian Polar Stations)	
4K4	Asian Islands between 65 Deg E long. To 170 Deg. W long	
4K2	Franz Josef Land (Russian Polar Stations)	40
4LA-4LZ	Georgia	21
4P-4S	Sri Lanka	22
4U	ITU Geneva	14
4U	United Nations Headquarters	05
4X, 4Z	Isreal	20
5A	Libya	34
5B, P3, H2	Cyprus	20
5H, 5I	Tanzania	37
5N, 5O	Nigeria	35
5R, 5S	Madagascar	39

<b>Prefix</b>	<b>Country</b>	<b>CQ Zone</b>
5T	Mauritania	35
5U	Niger	35
5V	Togo	35
5W	Western Sarnova	32
5X	Uganda	37
5Y, 5Z	Kenya	37
6O	Somalia	37
6V, 6W	Senegal	35
6Y	Jamaica	08
7J-7N	Japan	25
7O	Yemen	21, 37
7P	Lesotho	38
7Q	Malawi	37
7S	Sweden	14
7T-7Y	Algeria	33
7Z	Saudi Arabia	21
8J	Japan	25
8P	Barbados	08
8Q	Maldivs Is	22
8R	Guyana	09
8S	Sweden	14
8Z	Saudi Arabia	21
9A	Croatia	15
9G	Ghana	35
9H	Malta	15
9I, 9J	Zambia	36
9K	Kuwait	21
9L	Sierra Leone	35
9M2, 4	West Malaysia	28
9M6, 8	East Malaysia	28
9N	Nepal	22
9O-9T	Zaire	36
9U	Burundi	36
9V	Singapore	28
9X	Rwanda	36
9Y, 9Z	Trinidad and Tobago	09
A2	Botswana	38
A3	Tonga	32
A4	Oman	21
A5	Bhutan	22

<b>Prefix</b>	<b>Country</b>	<b>CQ Zone</b>
A6	United Arab Emirates	21
A7	Qatar	21
A8	Liberia	35
A9	Bahrain	21
AA-AL	USA	3, 4, 5
AM-AO	Spain	14
AT-AW	India	22
AP-AS	Pakistan	21
BS7	Scarborough Reef	27
BM, BO, BU, BV	Taiwan	24
BA, BD, BG, BT, BY	China	23, 34
C2	Nauru	31
C3	Andorra	14
C5	Gambia	35
C6	Bahamas	08
C8-C9	Mozambique	37
CA-CE	Chile	12
CE0	Easter Island, San Felix and San Ambrosia, Juan Fernandez Island	12
CE9	Antarctica	
CF-CK	Canada	1-5
CM, CO	Cuba	08
CN	Morocco	33
CP	Bolivia	10
CT	Portugal	14
CT3	Madeira Is.	14
CU	Azores	33
CV-CX	Uruguay	13
CY9	St. Paul Island	05
CY0	Sable Island	05
D2-3	Angola	36
D4	Cape Verde	35
D5	Liberia	35
D6	Comoros	39
DA-DM	Germany	14
DU-DZ	Philippines	27
E2	Thailand	26
E3	Eritrea	37
E4	Palestine	
EA-EH	Spain	14
EA6-EH6	Balearic Is.	14

<b>Prefix</b>	<b>Country</b>	<b>CQ Zone</b>
EA8-EH8	Canary Is.	33
EA9-EH9	Ceuta and Melilla	33
EI-EJ	Ireland	14
EK	Armenia	21
EL	Liberia	35
EP-EQ	Iran	21
ER	Maldova	16
ES	Estonia	15
ET	Ethiopia	37
EU, EV, EW	Byelorussia	16
EX	Kyrgyzstan	17
EY	Tajikistan	17
EZ	Turkmenistan	17
F, TM, TO-TQ	France	14
FG	Guadeloupe	08
FH	Mayotte	39
FJ, FS	Saint Martin	08
FK	New Caledonia	32
FM	Martinique	08
FO	Clipperton Is.	07
FO	French Polynesia	32
FP	St. Pierre & Miquelon Is.	05
FR, FG	Glorioso Is.	39
FR, FJ, FE	Juan de Nova (Europe)	39
FR, FT	Tromelin Is.	39
FR	Reunion Is.	39
FT8W	Crozet Is.	39
FT8X	Kerguelen Is.	39
FT8Z	Amsterdam & St. Paul Is.	39
FW	Wallis & Futuna Is.	32
FY	French Guiana	09
G, GX	England	14
GD, GT, MD	Isle of Man	14
GH, GJ	Jersey	14
GI, GN	Northern Ireland (UK)	14
GM, GS	Scotland (UK)	14
GU, GP	Guernsey	14
GW, GC	Wale (UK)	14
H4	Solomon Is.	28
HA, HG	Hungary	15

<b>Prefix</b>	<b>Country</b>	<b>CQ Zone</b>
HB	Switzerland	14
HB0	Liechtenstein	14
HC, HD	Ecuador	10
HC8, HD8	Galapagos Is.	10
HH	Haiti	08
HI	Dominican Republic	08
HJ, HK	Colombia	09
HK0	Malpelo Is	09
HK0	San Andres & Providencia	07
HL, DS, DT	South Korea	25
HO, HP, 3E, 3F	Panama	07
HQ, HR	Honduras	07
HS	Thailand	26
HV	Vatican	15
HZ	Saudi Arabia	21
IA-IZ	Italy	15, 33
IS0, IM0	Sardinia	15
J2	Djibouti	37
J3	Grenada	08
J4	Greece	20
J5	Guinea-Bissau	35
J6	St. Lucia	08
J7	Dominica	08
J8	St. Vincent & Grenadines	08
JA-JS	Japan	25
JD1	Minami-Tori-Shima	27
JD1	Ogasawara Is.	27
JT-JV	Mongolia	23
JW	Svalbard Is.	40
JX	Jan Mayen Is.	40
JY	Jordan	20
K, W, NA-NZ, AA-AK	United States of America	3, 4, 5
KC6	Belau (Western Caroline Is.)	27
KG4	Guantanamo Bay	08
KH0	Manana Is.	27
KH1	Baker & Howland Is.	31
KH2	Guam	27
KH3	Johnston Is.	31
KH4	Midway Is.	31
KH5	Palmyra Jarvis Is.	31

<b>Prefix</b>	<b>Country</b>	<b>CQ Zone</b>
KH5K	Kingman Reef	31
KH6	Hawaii	31
KH7	Kure Is.	31
KH8	American Samoa	32
KH9	Wake Is.	31
KL7	Alaska	1
KP1	Navassa Is.	08
KP2	Virgin Is.	08
KP3, KP4, WP	Puerto Rico	08
KP5	Desecheo Is.	08
LA-LN	Norway	14
LO-LW, AY, AZ	Argentina	13
LX	Luxembourg	14
LY	Lithuania	15
LZ	Bulgaria	20
M1, M0	United Kingdom	14
OA-OC	Peru	10
OD	Lebanon	20
OE	Austria	15
OF-OI	Finland	15
OH0	Aland Is.	15
OJ0	Market Reef	15
OK, OL	Czech Republic	15
OM	Slovak Republic	15
ON-OT	Belgium	14
OX	Greenland	40
OY	Faroes	14
OZ	Denmark	14
P2	Papua New Guinea	28
P4	Aruba	09
P5	North Korea	25
PA-PI	Netherlands	14
PJ2, 4, 9	Bonaire, Curacao (Neth Antilles)	09
PJ5-8	St. Maarten, Saba & St. Eustatius Is.	08
PP-PY	Brazil	11
PP0-PY0	Fernando de Noronha, St. Peters & St. Paul Rocks, Trinidad & Martin Vaz	11
PZ	Surinam	09
S0	Western Sahara	33
S2	Bangladesh	22
S4	South Africa	38

<b>Prefix</b>	<b>Country</b>	<b>CQ Zone</b>
S5	Slovenia	15
S7	Seychelles	39
S9	Sao Tome & Principe	36
SA-SM	Sweden	14
SN-SR	Poland	15
ST	Sudan	34
ST0	Southern Sudan	34
SU	Egypt	34
SV-SZ	Greece	20
SV/A	Mount Athos	20
SV5	Dodecanese	20
SV9	Crete	20
T2	Tuvalu	31
T30	W. Kiribati (Gilbert Is.)	31
T31	Central Kiribati (British Phoenix Is.)	31
T32	East Kiribati (Line Is)	31
T33	Banaba Is. (Ocean Is.)	31
T5	Somalia	37
T7	San Marino	15
T9, 4N4, 4O4	Bosnia-Herzegovina	15
TA-TC	Turkey	20
TF	Iceland	40
TG, TD	Guatemala	07
TI, TE	Costa Rica	07
T19	Cocos Is	07
TJ	Cameroon	36
TK	Corsica	15
TL	Central Africa	36
TN	Congo	36
TR	Gabon	36
TT	Chad	36
TU	Ivory Coast	35
TY	Benin	35
TZ	Mali	35
UA-UI1, 3, 6, RA-RZ	European Russia	16
UA2	Kaliningrad	15
UA-UI8, 9, 0 RA-RZ	Asiatic Russia	
UJ-UM	Uzbekistan	17
UN-UQ	Kazakhstan	17
UR-UZ, EM-EO	Ukraine	16

<b>Prefix</b>	<b>Country</b>	<b>CQ Zone</b>
V2	Antigua Barbuda	08
V3	Belize	07
V4	St. Kitts & Nevis	08
V5	Namibia	38
V6	Micronesia (East Caroline Is.)	27
V7	Marshall Is.	31
V8	Brunei	28
VA, VE, VF, VO, VY	Canada	1-5
VK, VI, AX	Australia	29, 30
VK0	Heard Is.	39
VK0	Macquarie Is.	30
VK9C	Cocos-Keeling Is.	29
VK9L	Lord Howe Is.	30
VK9M	Mellish Reef	30
VK9N	Norfolk Is.	32
VK9W	Willis Is.	30
VK9X	Christmas Is.	29
VP2E	Anguilla	08
VP2M	Montserrat	08
VP2V	British Virgin Is.	08
VP5	Turks & Caicos Is.	08
VP8	Falkland Is.	13
VP8, LU	South Georgia Is. South Orkney Is., South Sandwich Is.	13
VP8, CE9, HF0, LU, RA1	South Shetland Is.	13
VP9	Bermuda Is.	05
VQ9	Chagos Is.	39
VR6	Pitcairn Is.	32
VS6, VR2	Hong Kong	24
VU2, VU3	India	22
VU7	Andaman & Nicobar Is. (India)	26
VU4	Laccadive Is. (India)	22
XA-XI, 4A-4C	Mexico	06
XA4-X14	Revilla Gigedo	06
XJ	Canada	1-5
XT	Burkina Faso	35
XU	Cambodia	26
XW	Laos	26
XX9	Macao	24
XY-XZ	Myanmar	26
YA, T6	Afghanistan	21

<b>Prefix</b>	<b>Country</b>	<b>CQ Zone</b>
YB-YH	Indonesia	28
YI	Iraq	21
YJ	Vanuatu	32
YK	Syria	20
YL	Latvia	15
YN	Nicaragua	07
YT, YU, YZ, 4N	Yugoslavia	15
YV-YY, 4M	Venezuela	09
YV0	Ares Is.	08
Z2	Zimbabwe	38
Z3, 4N5	Macedonia	15
ZA	Albania	15
ZB2	Gibraltar	14
ZC4	Cyprus (United Kingdom Sovereign Bases)	20
ZD7	St. Helena	36
ZD8	Ascension Is.	36
ZD9	Tristan de Cunha & Gough Is.	38
ZF	Cayman Is.	08
ZK1	North & South Cook Is.	32
ZK2	Niue	32
ZK3	Tokelau Is.	31
ZL, ZM	New Zealand	32
ZL7	Chatham Is.	32
ZL8	Kermadec Is.	32
ZL9	Auckland & Campbell Is.	32
ZP	Paraguay	11
ZR-ZU	Republic of South Africa	38
ZS0, 1	Penguin Is.	38
ZS8	Prince Edward & Marion Is.	38

### List of Call-sign Blocks allotted by ITU

<b>Prefix</b>	<b>Country</b>	<b>Prefix</b>	<b>Country</b>	<b>Prefix</b>	<b>Country</b>
AAA-ALZ	USA	AMA-AOZ	SPAIN	APA-ASZ	PAKISTAN
ATA-AWZ	INDIA	AXA-AXZ	AUSTRALIA	AYA-AZZ	ARGENTINE
A2A-A2Z	BOTSWANA	A3A-A3Z	TONGA	A4A-A4Z	OMAN
A5A-A5Z	BHUTAN	A6A-A6Z	U.A.E.	A7A-A7Z	QATAR
A8A-A8Z	LIBERIA	A9A-A9Z	BAHRAIN	BAA-BZZ	CHINA
CAA-CEZ	CHILE	CFA-CKZ	CANADA	CLA-CMZ	CUBA
CNA-CNZ	MOROCCO	COA-COZ	CUBA	CPA-CPZ	BOLIVIA
CQA-CUZ	PORTUGAL	CVA-CXZ	URUGUAY	CYA-CZZ	CANADA
C2A-C2Z	NAURU	C3A-C3Z	ANDORRA	C4A-C4Z	CYPRUS
C5A-C5Z	GAMBIA	C6A-C6Z	BAHAMAS	C7A-C7Z	World Meteorological Organisation
C8A-C9Z	MOZAMBIQUE	DAA-DRZ	GERMANY	DSA-DTZ	SOUTH KOREA
<b>Prefix</b>	<b>Country</b>	<b>Prefix</b>	<b>Country</b>	<b>Prefix</b>	<b>Country</b>
DUA-DZZ	PHILIPPINES	D2A-D3Z	ANGOLA	D4A-D4Z	CAPE VERDE
D5A-D5Z	LIBERIA	D6A-D6Z	COMOROS	D7A-D7Z	SOUTH KOREA
D7A-D9Z	SOUTH KOREA	EAA-EHZ	SPAIN	EIA-EJZ	IRELAND
EKA-EKZ	ARMENIA	ELA-ELZ	LIBERIA	EMA-EOZ	UKRAINE

EPA-EQZ	IRAN	ERA-ERZ	MOLDOVA	ESA-ESZ	ESTONIA
ETA-ETZ	ETHIOPIA	EUA-EWZ	BELARUS	EXA-EXZ	KYRGYZ
EYA-EYZ	TAJIKISTAN	EZA-EZZ	TURKMENISTAN	E2A-E2Z	THAILAND
E3A-E3Z	ERITREA	E4A-E9Z	UNALLOTTED	HAA-HAZ	HUNGARY
HBA-HBZ	SWITZERLAND	HCA-HDZ	ECUADOR	HEA-HEZ	SWITZERLAND
HFA-HFZ	POLAND	HGA-HGZ	HUNGARY	HHA-HHZ	HAITI
HIA-HIZ	DOMINIC REP.	HJA-HKZ	COLOMBIA	HLA-HLZ	SOUTH KOREA
HMA-HMZ	NORTH KOREA	HNA-HNZ	IRAQ	HOA-HPZ	PANAMA
HQA-HRZ	HONDURAS	HAS-HSZ	THAILAND	HTA-HTZ	NICARAGUA
HUA-HUZ	EL SALVADOR	HVA-HVZ	VETICAN	HWA-HYZ	FRANCE
HZA-HZZ	SAUDI ARABIA	H2A-H2Z	CYPRUS	H3A-H3Z	PANAMA
H4A-H4Z	SOLOMON IS.	H5A-H5Z	UNALLOTTED	H6A-H7Z	NICARAGUA
H8A-H9Z	PANAMA	IAA-IZZ	ITALY	JAA-JSZ	JAPAN
JTA-JVZ	MONGOLIA	JWA-JXZ	NORWAY	JYA-JYZ	JORDAN
JZA-JZZ	INDONESIA	J2A-J2Z	DJIBOUTI	J3A-J3Z	GRENADA
J4A-J4Z	GREECE	J5A-J5Z	GUINEABISSAU	J6A-J6Z	ST. LUCIA
J7A-J7Z	DOMINICA	J8A-J8Z	ST.VINCENT/GRE NADINES	J9A-J9Z	UNALLOTTED
KAA-KZZ	U.S.A.	LAA-LNZ	NORWAY	LOA-LWZ	ARGENTINA
LXA-LXZ	LUXEMBOURG	LYA-LYZ	LITHUANIA	LZA-LZZ	BULGARIA
L2A-L9Z	ARGENTINA	MAA-MZZ	UNITED KINGDOM	NAA-NZZ	U.S.A.
OAA-OCZ	PERU	ODA-ODZ	LEBANON	OEA-OEZ	AUSTRIA
OFA-OJZ	FINLAND	OKA-OLZ	CZECH REPUBLIC	OMA-OMZ	SLOVAK REPUBLIC
ONA-OTZ	BELGIUM	OUA-OZZ	DENMARK	PAA-PIZ	NETHERLANDS
PJA-PJZ	NETHERLAND ANTILLES	PKA-POZ	INDONESIA	PPA-PYZ	BRAZIL
PZA-PZZ	SURINAME	P2A-P2Z	PAPUA/NEW GUINEA	P3A-P3Z	CYPRUS
P4A-P4Z	ARUBA	P5A-P9Z	NORTH KOREA	RAA-RZZ	RUSSIAN FEDERATIONS
SAA-SMZ	SWEDEN	SNA-SRZ	POLAND	SSA-SSM	EGYPT
SSN-STZ	SUDAN	SUA-SUZ	EGYPT	SVA-SZZ	GREECE
S2A-S3Z	BANGLADESH	S4A-S4Z	UNALLOTTED	S5A-S5Z	SLOVENIA
S6A-S6Z	SINGAPORE	S7A-S7Z	SEYCHELLES	S8A-S8Z	SOUTH AFRICA
S9A-S9Z	SAO TOME & PRINCIPE	TAA-TCZ	TURKEYALA	TDA-TDZ	GUATEMALA
TEA-TEZ	COSTA RICA	TFA-TFZ	ICELAND	TGA-TGZ	GUATEMALA
THA-THZ	FRANCE	TIA-TIZ	COSTA RICA	TJA-TJZ	CAMEROON
TKA-TKZ	FRANCE	TLA-TLZ	CENTRAL AFRICAN REPUBLIC	TMA-TMZ	FRANCE
TNA-TNZ	CONGO	TOA-TQZ	FRANCE	TRA-TRZ	GABON
TSA-TSZ	TUNISIA	TTA-TTZ	CHAD	TUA-TUZ	IVORY COAST
TVA-TXZ	FRANCE	TYA-TYZ	BENIN	TZA-TZZ	MALI
T2A-T2Z	TUVALU	T3A-T3Z	KIRIBATI	T4A-T4Z	CUBA
<b>Prefix</b>	<b>Country</b>	<b>Prefix</b>	<b>Country</b>	<b>Prefix</b>	<b>Country</b>
T5A-T5Z	SOMALIA	T6A-T6Z	AFGANISTAN	T7A-T7Z	SAN MARINO
T8A-T8Z	PALAU REP.	T9A-T9Z	BOSNIA & HERZEGOVINA	UAA-UIZ	RUSSIAN FED.
UJA-UMZ	UZBEKISTAN	UNA-UQZ	KAZAKSTAN	URA-UZZ	UKRAINE
VAA-VGZ	CANADA	VHA-VNZ	AUSTRALIA	VOA-VOZ	CANADA
VPA-VQZ	U.K.	VRA-VRZ	HONGKONG	VSA-VSZ	U.K.
VTA-VWZ	INDIA	VXA-VYZ	CANADA	VZA-VZZ	AUSTRALIA
V2A-V2Z	ANTIGUA	V3A-V3Z	BELIZE	V4A-V4Z	ST. KITTS & NEVIS
V5A-V5Z	NAMIBIA	V6A-V6Z	MICRONESIA	V7A-V7Z	MARSHALL IS.

V8A-V8Z	BRUNEI	V9A-V9Z	UNALLOTTED	WAA-WZZ	U.S.A.
XAA-XIZ	MEXICO	XJA-XOZ	CANADA	XPA-XP7	DENMARK
XQA-XRZ	CHILE	XSA-XSZ	CHINA	XTA-XTZ	BURKINAFASO
XUA-XUZ	CAMBODIA	XVA-XVZ	VIETNAM	XWA-XWZ	LAO
XXA-XXZ	PORTUGAL	XYA-XZZ	MYANMAR	YAA-YAZ	AFGANISTAN
YBA-YHZ	INDONASIA	YOKA-YIZ	IRAQ	YJA-YJZ	VANUATU
YKA-YKZ	SYRIA	YLA-YLZ	LATVIA	YMA-YMZ	TURKEY
YNR-YNZ	NICARAGUA	YOA-YRZ	ROMANIA	YSA-YSZ	EL SALVADOR
YTA-YUZ	YUGOSLAVIA	YVA-YYZ	VENEZUELA	YZA-YZZ	YUGOSLAVIA
Y2A-Y9Z	GERMANY	ZAA-ZAZ	ALBANIA	ZBA-ZJZ	U.K.
ZKA-ZMZ	NEW ZEALAND	ZNA-ZOZ	U.K.	ZPA-ZPZ	PARAGUAY
ZQA-ZQZ	U.K.	ZRA-ZUZ	SOUTH AFRICA	ZVA-ZZZ	BRAZIL
Z2A-Z2Z	ZIMBABWE	23A-23Z	MACEDONIA	Z4A-Z9Z	UNALLOTTED
2AA-2ZZ	U.K.	3AA-3AZ	MONACO	3BA-3BZ	MAURITIUS
3CA-3CZ	EQUATORIAL GUINEA	3DA-3DM	SWAZILAND	3DN-3DZ	FIJI
3EA-3FZ	PANAMA	3GA-3GZ	CHILE	3HA-3UZ	CHINA
3VA-3VZ	TUNISIA	3WA-3WZ	VIETNAM	3XA-3XZ	GUINEA
3YA-3YZ	NORWAY	3ZA-3ZZ	POLAND	4AA-4CZ	MEXICO
4DA-4IZ	PHILIPPINES	4JA-4KZ	AZERBAIJAN	4LA-4LZ	GEORGIA
4MA-4MZ	VENEZUELA	4NA-4OZ	YUGOSLAVIA	4PA-4SZ	SRILANKA
4TA-4TZ	PERU	4UA-4UZ	UNITED NATIONS	4VA-4VZ	HAITI
4WA-4WZ	UNALLOTTED	4XA-4XZ	ISREAL	4YA-4ZZ	UNALLOTTED
5AA-5AZ	LIBYA	5BA-5BZ	CYPRUS	5CA-5GZ	MOROCCO
5HA-5IZ	TANZANIA	5JA-5KZ	COLOMBIA	5LA-5MZ	LIBERIA
5NA-5OZ	NIGERIA	5PA-5QZ	DENMARK	5RA-5SZ	MADAGASCAR
5TA-5TZ	MAURITANIA	5UA-5UZ	NIGER	5VA-5VZ	TOGOLESE REPUBLIC
5WA-5WZ	WEST SAMOA	5XA-5XZ	UGANDA	5YA-5ZZ	KENYA
6AA-6BZ	EGYPT	6CA-6CZ	SYRIA	6DA-6JZ	MEXICO
6KA-6NZ	S. KOREA	6OA-6OZ	SOMALI	6PA-6SZ	PAKISTAN
6TA-6UZ	SUDAN	6VA-6WZ	SENEGAL	6XA-6XZ	MADAGASCAR
6YA-6YZ	JAMAICA	6ZA-6ZZ	LIBERIA	7AA-7IZ	INDONESIA
7JA-7NZ	JAPAN	7OA-7OZ	YEMEN	7PA-7PZ	LESOTHO
7QA-7QZ	MALAWI	7RA-7RZ	ALGERIA	7SA-7SZ	SWEDEN
7TA-7YZ	ALGERIA	7ZA-7ZZ	SAUDI ARABIA	8AA-8IZ	INDONESIA
8JA-8NZ	JAPAN	8OA-8OZ	BOTSWANA	8PA-8PZ	BARBADOS
8QA-8QZ	MALDIVES	8RA-8RZ	GUYANA	8SA-8SZ	SWEDEN
8TA-8YZ	INDIA	8ZA-8ZZ	SAUDI ARABIA	9AA-9AZ	CROATIA
9BA-9DZ	IRAN	9EA-9FZ	ETHIOPIA	9GA-9GZ	GHANA
<b>Prefix</b>	<b>Country</b>	<b>Prefix</b>	<b>Country</b>	<b>Prefix</b>	<b>Country</b>
9HA-9HZ	MALTA	9IA-9JZ	ZAMBIA	9KA-9KZ	KUWAIT
9LA-9LZ	SIERALEONE	9MA-9MZ	MALAYSIA	9NA-9NZ	NEPAL
9OA-9TZ	CONGO	9UA-9UZ	BURUNDI	9VA-9VZ	SINGAPORE
9WA-9WZ	MALAYSIA	9XA-9XZ	RWANDA	9VA-9ZZ	TRINIDAD & TOBAGO

## ANNEXURE-III

### A Sample Question Paper for Amateur Radio Licencing Examination

#### SECTION-A

#### Radio Theory and Practice

1. What is Ohm's law? A resistor has the following colour bands: RED, RED, ORANGE & GOLD respectively. What is the value of this resistor?
2. State whether 'TRUE' or 'FALSE' and correct the 'FALSE' statements:
  - (a) When two resistors are connected in parallel, their resistance increases.
  - (b) A capacitor allows DC current to pass through it.
  - (c) When two capacitors are connected in parallel, their capacitance decreases.
  - (d) In a P-N junction diode, flow of current is possible only when the negative pole of the battery is connected to the p-type semiconductor and positive pole to n-type semiconductor.
  - (e) Centre tapped transformer secondary is not essential for a bridge rectifier circuit.
  - (f) In a transistor amplifier circuit, the 'emitter' is always reverse biased and 'collector is always forward biased.
  - (g) In a PNP transistor, the 'collector' is applied with a negative voltage.
  - (h) SWR value is more than one for a matched system.
  - (i) The fourth band in a resistor is silver coloured. The tolerance of this resistor is 10%.
  - (j) Two capacitors with the values 5 mFd & 10 mFd are connected in parallel. The 5 mFd capacitor has a voltage rating of 10 volts and the 10 mFd capacitor has a voltage rating of 6 volts. We can apply 9 volts to this circuit without damaging the 10 mFd capacitor.
3. Draw the schematic diagram of the transmitter you intend to build for ham radio operation and explain the function of each stage in brief.
4. Explain the working function of the antenna you intend to use for ham radio transmissions.
5. Draw the block diagram of a super-heterodyne receiver. What are superiorities of this type of receiver over the TRF receivers?
6. Write short notes on:
  - (a) Image frequency in a super-heterodyne receiver.
  - (b) Ionosphere.
  - (c) Single Side Band transmission.
  - (d) Percentage of modulation.
  - (e) Selectivity & sensitivity of receiver.
  - (f) Colpitts oscillator.
  - (g) Skip distance.

- (h) Differences between 'fadeout' and 'fading'.
- (i) A.G.C.
- (j) B.F.O.

## SECTION-B

### Rules & Regulations

1. What is a distress message? What action would you take if you receive a distress message?
2. Explain the meaning of the following:  
QRX 10 minutes, QSY 14.155 MHz, QRU?, QRV, QRL, KN, VA, AS, QSB, QRS.
3. Describe the procedure of establishing a contact with another amateur station using radiotelephony and radiotelegraphy.
4. What do you mean by 'Amateur Radio Service'?
5. State whether 'TRUE' or 'FALSE'. Correct the 'FALSE' statements.
  - (a) In India, a Grade-I licence holder is allowed to use 400 watts of power in certain sub-bands.
  - (b) In India, A Grade-II licence holder can directly use radiotelephony after getting his licence.
  - (c) In India, ham radio operators are allowed to use the frequency band 7000 kHz to 7300 kHz.
  - (d) In India, an amateur radio operator can handle third party messages.
  - (e) Amateur radio operators are allowed to use secret language for communication.
  - (f) 4S7VK is a call-sign of USA.
  - (g) An amateur radio operator should maintain the secrecy of communication.
  - (h) An amateur radio operator is allowed to communicate with the Military during emergency.
  - (i) A message passed on by an amateur radio operator to a third party by taking money is called 'QSP'.
  - (j) Third party messages can be handled by an amateur radio operator during a disaster.
6. What are the amateur radio bands of frequencies? Can a Restricted Grade Licence holder use High Frequencies (HF) for communication?
7. What is the condition to get a 'Voice endorsement' by a Grade-II licence holder?

## Annexure-IV

### Nomenclature of the Frequency and Wavelength Bands used in Radio Communication

As per the International Radio Regulations, the radio spectrum is subdivided into nine frequency bands, which are designated by progressive whole numbers in accordance with the following table. As the unit of frequency is the hertz (Hz), frequencies shall be expressed:

- in Kilohertz kHz, upto and including 3000 kHz;
- in megahertz MHz, above 3 MHz, up to and including 3000 MHz;
- in gigahertz GHz, above 3 GHz, up to and including 3000 GHz.

For bands above 3000 GHz, i.e. centimillimetric waves, micrometric waves and decimicrometric waves, it would be appropriate to use terahertz THz.

However, where adherence to these provisions would introduce serious difficulties, for example in connection with the notification and registration of frequencies, the lists of frequencies and related matters, reasonable departures may be made.

Band Number	Band Symbols	Frequency Range lower limit exclusive, upper limit inclusive	Corresponding Metric Subdivision	Metric Abbreviations for the bands
4	VLF	3 to 30 kHz	Myriametric waves	B.Mam
5	LF	30 to 300 kHz	Kilometric waves	B.km
6	MF	300 to 3000 kHz	Hectometric waves	B.hm
7	HF	3 to 30 MHz	Decametric waves	B.dam
8	VHF	30 to 300 MHz	Metric waves	B.m
9	UHF	300 to 3000 MHz	Decimetric waves	B.dm
10	SHF	3 to 30 GHz	Centimetric waves	B.cm
11	EHF	30 to 300 GHz	Millimetric waves	B.mm
12		300 to 3000 GHz	Decimillimetric waves	

Note 1:

“Band Number N” extends from  $0.3 \times 10^N$  to  $3 \times 10^N$  Hz, e.g., Band No. 7 is the HF (High Frequency) band ranging from  $0.3 \times 10^7$  to  $3 \times 10^7$  Hz, i.e. 3000000 Hz (3 MHz) to 30000000 Hz (30 MHz)

Note

2:

Symbols and prefixes: Hz=hertz, k=kilo  $10^3$ , M=mega  $10^6$ , G=giga  $10^9$ , T=tetra  $10^{12}$