

# C-Band 5.6GHz FMCW Radar

Iulian Rosu, YO3DAC / VA3IUL, Filip Rosu, YO3JMK, <http://qsl.net/va3iul>

The presented FMCW radar project is operating in C-Band, 5.6GHz, have a wide bandwidth (800MHz), and uses two separate receivers with independent antennas, which makes available a new approach named Directional of Arrival (DoA).

## Understanding FMCW Radar waveforms

Continuous wave radar signals with a linear frequency modulation are applied in many radar systems. FMCW radars have low transmit power compared to pulse radar systems. This allows the radar to be smaller in size and lower in cost.

- An important feature of the FMCW radar is the zero-blind range, as both, the transmitter and the receiver are always ON. Pulse radars suffers from blind-range and blind-speed phenomenon's, due to pulse (frequency) repetition time characteristic of the signal.
- Key performance indicators of FMCW radars are: range resolution, ambiguity and accuracy of measured distance range, and the radial velocity (speed) of the target. While the resolutions depend on signal bandwidth and the length of the chirp (period of the modulation signal), range accuracy requires in the first place a high signal to noise of the radar echo signal.

The FMCW radar presented in this project use a Sawtooth modulation signal.

- An FMCW radar transmits a signal called “**chirp**”. A chirp is a sinusoid whose frequency increases linearly with time, as shown in the plot below.
- A Voltage Controlled Oscillator (VCO) generates the chirp signal. The VCO frequency is controlled via tuning line by a ramp generator, having a **Sawtooth, Triangle, or Sinusoid**, waveform.

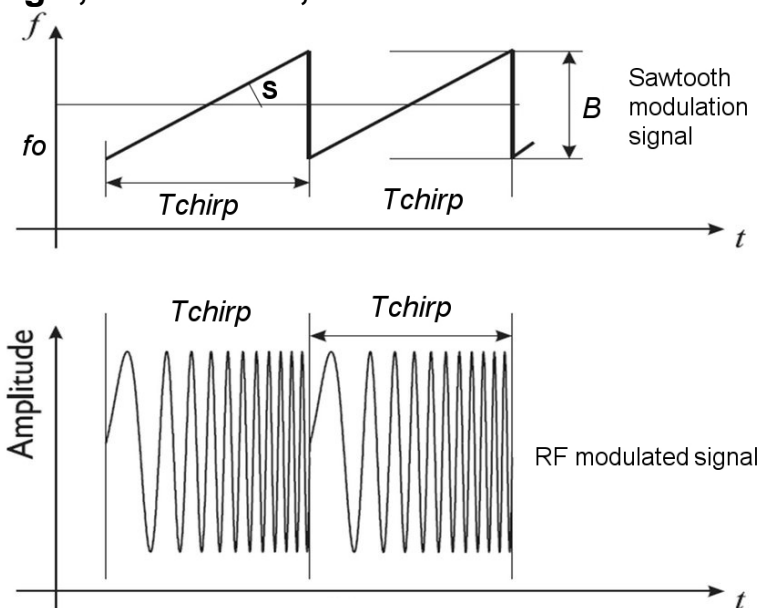

FMCW radar signal using Sawtooth ramp

- From the plot above can be seen that the frequency of the chirp increases linearly with ascending **sawtooth** ramp.
- A chirp is characterized by: a **start frequency  $f_0$**  (in Hz), a **Bandwidth  $B$**  (in Hz), and by a **sweep time duration  $T_{chirp}$**  (in seconds).
- The **Slope  $S$**  of the ramp defines the rate at which the chirp ramps up. The slope  **$S$**  is in Hz/sec (or MHz/usec), and is given by:

$$S = B / T_{chirp} \quad (1)$$

For example, if the chirp is sweeping a bandwidth of 4 GHz in a period of time of 40usec, this corresponds to a Slope of 100 MHz/usec.

- The chirp is transmitted by the TX antenna towards the target.
- The chirp is reflected by the target object and the reflected chirp is received at the RX antenna.
- The received RX-signal and the transmitted TX-signal are “mixed” and the resulting signal is called an “**IF-signal**”, signal which is processed by the radar system to obtain the required information as: **range (distance to the target)  $R$** , **target position**, and **target velocity  $v_r$**  (speed).

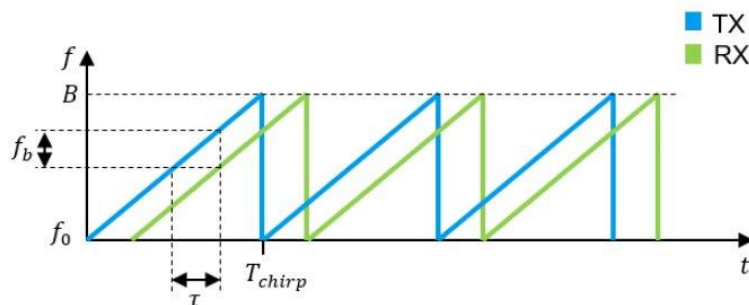

TX and RX FMCW radar signals using Sawtooth modulation signal

- The top figure shows the TX-signal and the RX-signal that is reflected from an object. Note that the RX-signal is just a delayed version of the TX-signal.
- Signal **propagation time  $\tau$**  (tau) in seconds, denotes the **round-trip time** between the radar and the target object.
- The frequency of the IF-signal at the mixers output is the difference of the instantaneous frequency of the TX-chirp and RX-chirp.
- A single object in front of the radar produces an IF-signal that is a constant frequency tone named **beat frequency  $f_b$** .
- The bandwidth of interest of the IF-signal depends on the desired maximum distance to the target (maximum beat frequency).
- The IF-signal is typically digitized (LPF+ADC) for further processing on a DSP.
- The IF-bandwidth is thus limited by the **ADC sampling rate  $F_s$** .
- The ADC sampling rate  **$F_s$**  limits the **maximum range of the radar  $R_{max}$** :

$$R_{max} = F_s * c * 2 * S = F_s * c * 2 * (B / T_{chirp}) \quad (2)$$

where  **$c$**  is the speed of light,  **$S$**  is the ramp Slope,  **$B$**  is bandwidth,  **$T_{chirp}$**  is sweep time.

The Sawtooth function versus time  $f(t)$  is given by:

$$f(t) = f_o + (B / T_{\text{chirp}}) * t \quad (3)$$

where:  $f_o$  is the start frequency (in Hz),  $B$  is the bandwidth (in Hz),  $T_{\text{chirp}}$  is sweep time or the chirp length (in seconds), and  $t$  is the time (in seconds).

When the target reflects the TX radiated signal, at the receiver, the RX demodulated signal has the same sawtooth waveform as the TX modulated signal, but delayed in time by the round-trip **propagation time  $\tau$** .

The **range R** (distance to the target) is calculated as follows:

$$R = (c * \tau) / 2 \quad (4)$$

with:  $c$  is the speed of light (meters/second), and  $\tau$  is the propagation time (in seconds). As was mentioned, at the receiver, a certain frequency shift between TX and RX signals, called **beat frequency ( $f_b$ )** is introduced when the target reflects the radar wave.

- Signal round-trip propagation time  $\tau$  and beat frequency  $f_b$  are equivalent and are linked together according to:

$$(\tau / T_{\text{chirp}}) = (f_b / B) \quad (5)$$

Using the equations (4) and (5), the distance range  $R$  could be also expressed as:

$$R = (c / 2) * (T_{\text{chirp}} / B) * f_b \quad (6)$$

- The distance range equation (6) is valid only if the target is not moving, for example if the echo signal have no Doppler shift.
- For a **single target that is not moving**, the **beat frequency  $f_b$**  is expressed as:

$$f_b = (2 * R * B) / (c * T_{\text{chirp}}) \quad (7)$$

$$f_b = (\tau * B) / T_{\text{chirp}} \quad (8)$$

- A **moving target** induces a **Doppler frequency shift  $f_D$** , which is related to the speed of the target  $v_r$  and also to the wavelength  $\lambda$  (frequency) of the TX signal:

$$f_D = (2 * v_r) / \lambda = (2 * v_r * f_c) / c \quad (9)$$

- The relative **target velocity** (speed)  $v_r$  in meters per second is given by:

$$v_r = (c * f_D) / (2 * f_c) \quad (10)$$

where:  $f_D$  is the Doppler frequency in Hz,  $f_c$  is the TX carrier (central) frequency in Hz, and  $c$  is the speed of light in meters per second.

- The beat frequency  $f_b$  is not only related to the range  $R$  of the target, but also to its relative radial velocity with respect to the radar.

For a moving target, the beat frequency  $f_b$  includes two frequency components:  $f_\tau$  due to signal propagation time delay  $\tau$ , and the frequency shift  $f_D$  due to the Doppler effect:

$$f_b = f_\tau + f_D = (2*B*R) / (c*T_{chirp}) + (2*\mathcal{V}_r) / \lambda \quad (11)$$

where:  $\mathcal{V}_r$  is the **radial velocity** (speed of the target in meters per second),  $\lambda$  is the TX signal wavelength in meters,  $B$  is the bandwidth in Hz,  $R$  is the distance range in meters.

• The beat frequency equation (11) contains two unknown variables,  $R$  and  $\mathcal{V}_r$ . Therefore, **when using a sawtooth modulation signal, and if the target is moving**, the measurement of the beat frequency  $f_b$  is insufficient to determine the range  $R$  and radial velocity (speed)  $\mathcal{V}_r$  of the target.

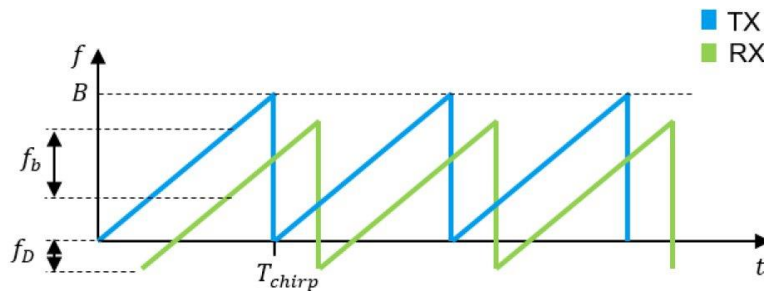

Frequency shift in the echo radar signal due to Doppler effect and range

To solve the issues of moving target, few solutions can be used:

1. First solution would be to replace the **sawtooth** modulation signal, with a **triangular** signal, having two different slopes, up and down.

This results in having two chirps, one positive (up-chirp) and one negative (down-chirp). Thus, will be two independent measurements of the beat frequency:  $f_{b1}$  and  $f_{b2}$ .

$$f_{b1} = (2*B*R) / (c*T_{chirp}) + 2*\mathcal{V}_r \quad (12)$$

$$f_{b2} = - (2*B*R) / (c*T_{chirp}) + 2*\mathcal{V}_r \quad (13)$$

Equations (12) and (13) for  $f_{b1}$  and  $f_{b2}$ , can be used for finding the range  $R$  and speed  $\mathcal{V}_r$ .

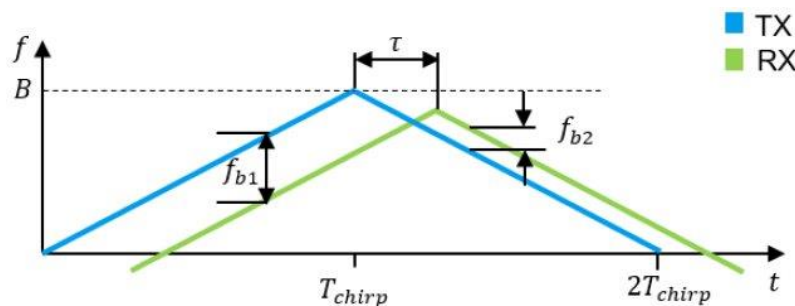

Linear FMCW radar with up-chirp and down-chirp using triangular waveform

- The advantage of using the **triangular waveform** is the ease of implementation and the avoidance of sharp frequency transitions compared to sawtooth waveforms.
- The drawback of triangular waveform is when have multi target situations, and range and radial velocity cannot be resolved unambiguously by two consecutive chirps measuring different beat frequencies. This causes “ghost” targets which can be resolved by additional chirps with different slopes transmitted in FMCW radar.

2. A second solution, for solving simultaneous range and velocity measurements, is to use a frame (a block) of very fast **sawtooth** waveforms (chirps). This waveform is called **Chirp Sequence (CS)** and consists out of several very short FMCW chirps each with a duration of  $T_{chirp}$  transmitted in a block of length  $T_{frame}$ . Due to the fact that a single chirp is very short, the beat frequency  $f_b$  is mainly influenced by signal propagation time, and the Doppler frequency shift  $f_D$  can be neglected in the first processing step.

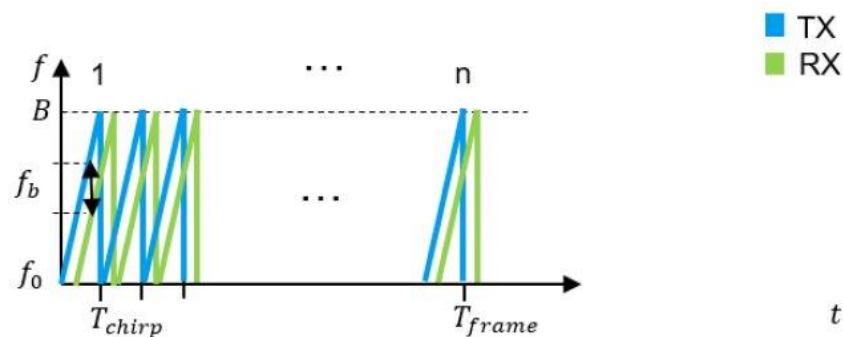

Chirp Sequence using very short sawtooth chirps transmitted in blocks (frames)

Then, under the assumption that the radial velocity is  $v_r = 0$ , the target range  $R$  (so the beat frequency  $f_b$ ), is determined as in normal FMCW by the equation (6).

- In **Chirp Sequence CS**, the radial velocity (speed)  $v_r$  is not measured during a single chirp, but instead over a block of consecutive chirps with the duration of  $T_{frame}$ .
- In the signal processing, a second Fourier transformation is performed along the time axis, which will then yield Doppler frequency shift  $f_D$ .
- The velocity resolution of the radar is inversely proportional to the frame time ( $T_{frame}$ ) and is given by:

$$v_{res} = \lambda / T_{frame}$$

In the Chirp Sequence method (using sawtooth waveform), usually the following values for  $T_{chirp}$ ,  $T_{frame}$ , and for bandwidth  $B$  are used:

- $T_{chirp}$  is between few microseconds up to hundred microseconds, and number of chirps (periods) inside of the block is typically between 100 and 1000.
- $T_{frame}$  is defined by the desired radial velocity and is about 20 milliseconds.
- Bandwidth  $B$  (which defines the range resolution) depends by the operating frequency band and varies between about 100MHz and 5GHz.

## Linearity of the Transmitted Signal

- There are several effects which reduce the linearity of the signal, which in turn reduces the FMCW radar performance.

If occur a slow frequency deviation from a perfect linear signal slope over a certain bandwidth, the beat frequency  $f_b$  will exhibit a trend to change.

This happens due to the down conversion of the received signal with the instantaneous transmit frequency.

This situation will decrease the measured range, decrease the accuracy and resolution of the radial velocity estimation, as the beat frequency measurement is less accurate.

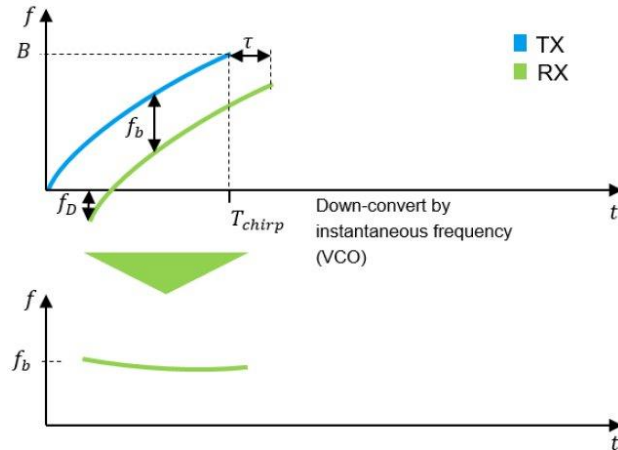

Beat frequency  $f_b$  variation due to nonlinear shape of the frequency deviation

Another possible distortion in the transmit signal are ripples on the TX signal.

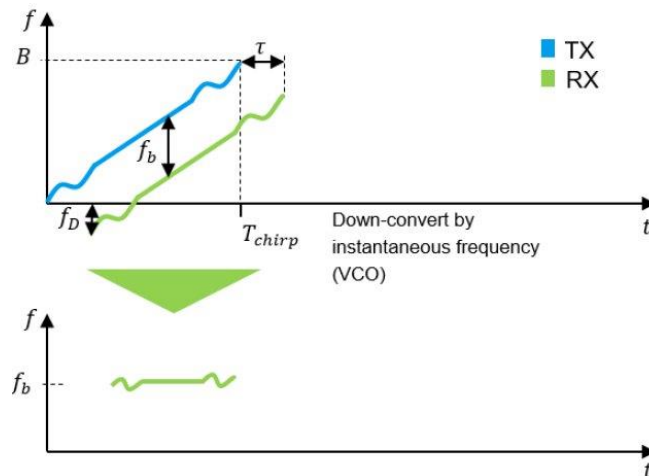

Ripple on TX signal and resulting variation of the beat frequency  $f_b$

- The frequency deviation distortions affect the measurement accuracy of the beat frequency and causes unwanted side-lobes to appear in the received signal spectrum.
- These distortions affect the range and velocity resolutions, and the measurement accuracy during the FMCW signal processing.
- The main reason of the frequency deviation distortion of the TX signal is the nonlinearity (MHz/Volt) of the VCO (voltage controlled oscillator), and to be more

accurate, the principal contributor is the nonlinear characteristic (capacitance vs reverse voltage) of the varactor diode which is used to change the oscillator frequency. However, the project presented here do not use a varactor in its VCO.

The **range resolution**  $R_{res}$  which is the ability of the FMCW Radar to distinguish between two adjacent target objects, is given by:

$$R_{res} = c / (2*B) \quad (14)$$

- A better range resolution  $R_{res}$  (in meters) requires a higher bandwidth  $B$  (in Hz).

For example, a signal bandwidth  $B$  of 100MHz determines a range resolution of 1.5m, and a signal bandwidth  $B$  of 800MHz (as the radar in this project has) determines a range resolution of 0.18m.  $(3*10^8)/(2*800*10^6)$

The FMCW radial velocity (speed) resolution  $v_{res}$  in meters per second is defined by the TX central frequency  $f_c$  and by the chirp length  $T_{chirp}$ :

$$v_{res} = c / (2*f_c*T_{chirp}) \quad (15)$$

where:  $f_c$  is the TX central frequency (in Hz), and  $T_{chirp}$  is the chirp length (in seconds).

- A better velocity (speed) resolution requires higher TX frequency or longer measurement time (longer chirp, or longer period).

For example, a TX frequency of 5.8GHz and a chirp length of 10msec gives a radial velocity (speed) resolution of 2.6 meters/second:  $(3*10^8) / [2*(5.8*10^{10})*(10^{-3})]$

## Directional of Arrival DoA (Angle of Arrival AoA)

Inspired by human auditory system, Direction of Arrival (DoA) technique could be implemented in a radar or a localization system.

- A person is able to determine the Direction of Arrival (DoA) of a sound by utilizing a three-stage process:
  - One's ears act as acoustic sensors and receive the signal.
  - Because of the separation between the ears, each ear receives the signal with a different time delay.
  - The human brain, does a large number of calculations to correlate information and compute the location of the received sound. The human brain is capable of distinguishing between multiple signals that have different directions of arrival.
- Electrical smart antenna systems work the same way using two (or more) antennas instead of two ears, and a digital signal processor instead of the human brain.

Thus, based on the time delays due to the impinging signals onto the antenna elements, the digital signal processor computes the direction-of-arrival (DoA) of the signal-of-interest (SOI), and then it adjusts the excitations (gains and phases of the signals) to produce a radiation pattern that focuses on the SOI while tuning-out any interferers or signals-not-of-interest (SNOI).

This technique could be used for many applications as: localization, tracking, and gesture recognition. Rejecting interferers coming from unwanted directions, represents a major advantage for radar systems.

- By exploiting the incident-angle-dependent magnitude and phase differences between the two antennas and applying signal processing algorithms, the directional-of-arrival DoA of an incident RF signal can be estimated.

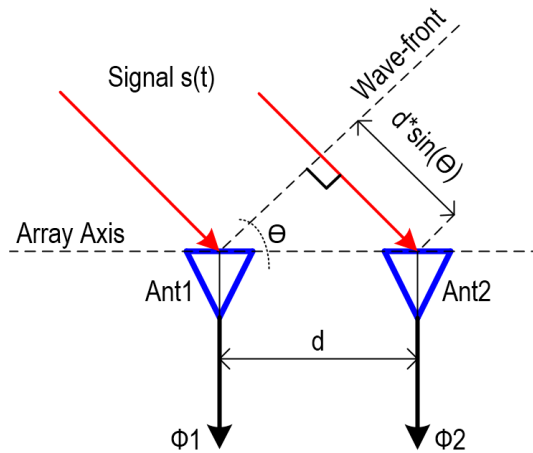

Direction of Arrival using an array with two antenna elements

- It is assumed that the narrowband RF signals  $s(t)$  are generated by a source situated in the far-field of the two-elements array antenna, and the impinging signal on the antennas is approximately a uniform plane wave (wave-front).
- The RF signals emitted by the source are parallel one to each other, and perpendicular to the wave-front plane.
- With respect to the signal that goes to the antenna **Ant1**, the signal which goes to antenna **Ant2** experience a time delay  $\Delta\tau$  in seconds:

$$\Delta\tau = [d \cdot \sin(\Theta)] / c \quad (16)$$

where:  $d$  is the distance between antennas (in meters),  $c$  is the speed of light (wave speed in m/sec), and  $\Theta$  is the angle made by the wave-front plane and array axis.

- Phase changes ( $\Phi1$  and  $\Phi2$ ) over the antennas are determined by the incoming angle of the RF signals made with the array axis.
- If  $s(t)$  is an RF signal with carrier frequency  $f_c = c/\lambda$ , then the time delay  $\Delta\tau$  corresponds to a phase shift  $\Delta\Phi$ :

$$\Delta\Phi = \Phi2 - \Phi1 = [2 \cdot \pi \cdot d \cdot \sin(\Theta)] / \lambda \quad (17)$$

where:  $\lambda$  is the wavelength of the RF signal (in meters).

- If the element spacing is exactly  $d = \lambda/2$ , it can be further simplified as:

$$\Delta\Phi = [\pi \cdot \sin(\Theta)]$$

- The approach of using only two antennas for finding directional-of-arrival (angle-of-arrival) of the signals, can be used only for one-direction incoming signals.
- When using only two antennas, the measurement could be noisy and ambiguous.
- These issues can be solved using more than two antennas in the array.



## C-Band 5.6GHz FMCW Radar

The core of the presented FMCW radar system is the push-push VCO (voltage-controlled oscillator), which has a good linearity over more than 800MHz sweep frequency range.

### Push-Push VCO - Schematic and Functionality

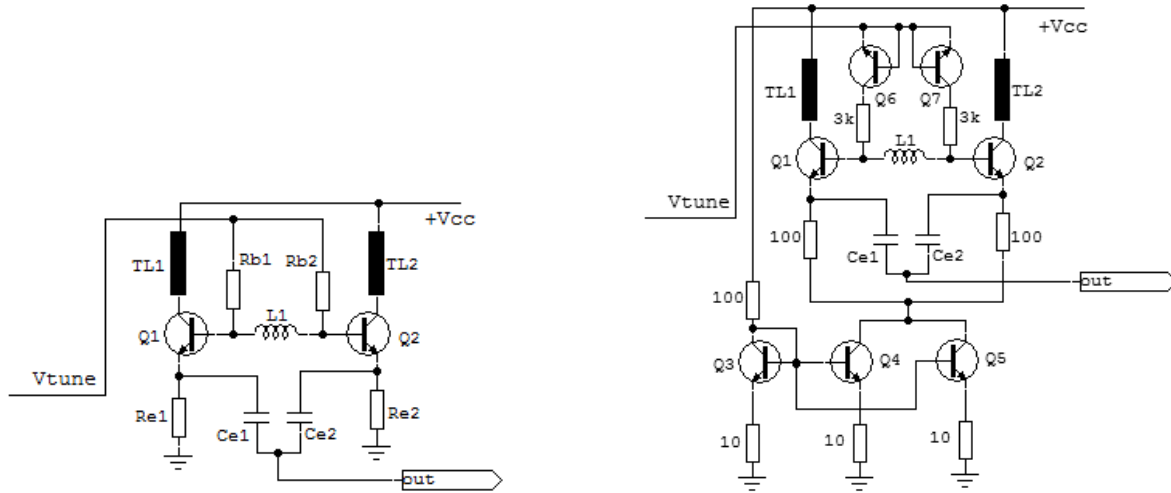

5.6GHz Push-Push VCO – Left: VCO basic circuit – Right: VCO with temperature compensated bias

In this project, the 5.6GHz push-push VCO was built using two SiGe [BFP620](#) transistors having transition frequency ( $f_T$ ) of 65GHz.

More information about this Push-Push VCO can be find here:

[SiGe Push-Push VCO for Low-Power C-Band FMCW High-Resolution Radar Applications](#)

The sawtooth ramp generator was built using three BJT transistors followed by an OpAmp buffer (LM358), which provides a low output impedance to the Vtune line.

The FMCW signal generated by the VCO goes to an emitter follower buffer (Q6) and later is amplified by the Q7 transistor. A Wilkinson splitter is used to distribute the signal to the power amplifier and also to the RX mixers.

For making the 5.6GHz transmitter power amplifier few options are:

An option is to build a 0.5W power amplifier using three SiGe [BFP650](#) transistors, connected in parallel.

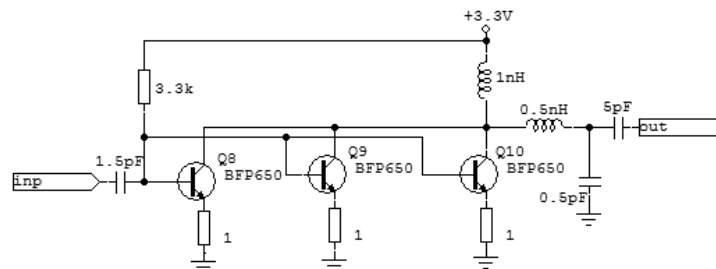

5.6GHz, 0.5W Power Amplifier

The gain of this power amplifier is about 14dB, at +27dBm output power into a 50Ω load.

Another option for the PA, is to use an external [RF power amplifier](#), This external power amplifier was initially designed to boost the output power of the wireless remotes which control flying drones.

The external power amplifier used in this project was designed with two SiGe-5004L power amplifier ICs connected in parallel with help of two printed Wilkinson combiners (see the picture below).

In the frequency range 5GHz-6GHz, using constant envelope signals (as FMCW signal), the output power of this amplifier could be up to +33dBm (2W), depending by the input power.

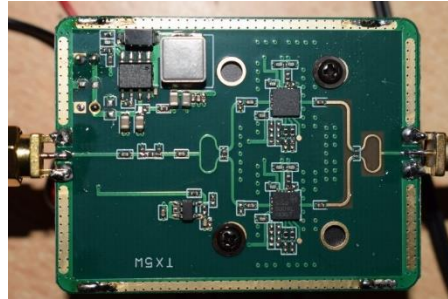
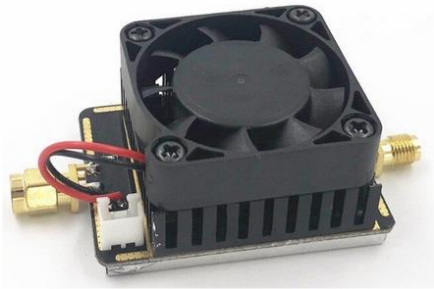

5.8GHz 2W Power Amplifier made with two SiGe-5004L in parallel

## Receiver LNAs, Mixers, Splitter

The FMCW signal from the VCO is amplified by the Q7 transistor and later, using a Wilkinson splitter, the signal is divided: one side to the power amplifier, and the other side to the mixers of the two receivers. Both receivers are identical, using active mixers IAM-81008, followed by active low-pass filters at the IF output.

The [IAM-81008](#) active mixer have about 5dB gain at 5.6GHz. Having an active mixer, and if the radar system uses an external power amplifier with more than 1W output power, there is not necessary to use an LNA (low noise amplifier) in front of the receiver mixer. If lower TX power is used, the receiver may need to use an [LNA](#) in front of the RX mixer:

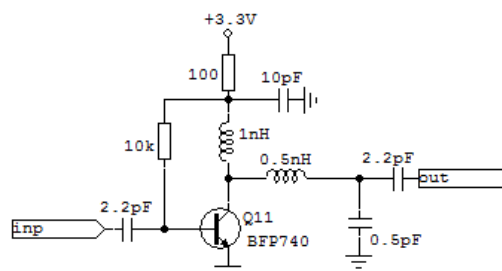

5.6GHz LNA, 16dB Gain and 0.5dB noise figure

At the IF output of the RX mixer, the baseband signal is low-pass filtered and amplified by [MC33078](#) operational amplifiers which has high-gain bandwidth product of 16MHz.

To get good power rails isolation between the two receivers, each circuit block has its own DC regulators. Also, the VCO has its own RF shield, and the PA the same.

## Horn Antennas

The C-band FMCW radar uses for measurements three pyramidal horn antennas, one antenna at the output of the transmitter and two antennas in front of the receivers.

The horn antennas were built using 0.8mm double-side copper plated PCB board, material which is easy to cut and solder. The interior edges of the horn antennas were soldered, when the exterior edges were united using copper tape.

However, only the interior edges need to be soldered.

A typical horn antenna design comprises three parts:

### 1. The feed port of the horn antenna.

- Horn antennas are typically excited using a connector probe or a waveguide port.

In this project, the designed pyramidal horn antenna uses as the feed port an SMA connector from whom center pin is soldered an RF probe, having 11mm length and 2.5mm thickness.

### 2. The waveguide mode transformer.

- The horn antennas made for this project are based on WR159 rectangular waveguide type, which covers 4.64GHz to 7.05GHz band.
- For rectangular waveguides, the dominant mode is TE<sub>10</sub>.  
The TE<sub>10</sub> means that during propagation through the waveguide the electric field is perpendicular to the direction of the propagation.

### 3. The radiating aperture of the horn antenna.

- The excited wavefront propagates along the rectangular waveguide and radiating outward via the pyramidal radiating aperture.
- The horn antenna may be considered as an impedance match between the waveguide feeder and free space (which has an impedance of 377 ohms), by having a flared end to the waveguide.

By matching the impedance of the guide to that of free space or vice versa, it helps suppress signals travelling via unwanted modes in the waveguide from being radiated and it provides significant level of directivity and gain.

- A pyramidal horn antenna is constructed by extending the E-plane and H-plane of a rectangular waveguide, and its radiation characteristics are essentially a combination of the characteristics of the E-plane and H-plane of the horn antenna.

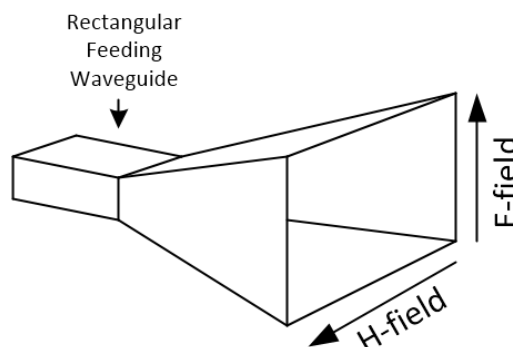

Pyramidal Horn Antenna E-field and H-field directions

The Top, Bottom and the Sides views of the horn antenna (4.64GHz-7.05GHz) are depicted in the figure below, and shows the location of the feed port, the dimensions of the RF probe, and the outer dimensions of the antenna (all dimensions are in mm).

The VSWR of the horn antenna in the frequency range 5GHz to 6GHz is better than 1.2:1

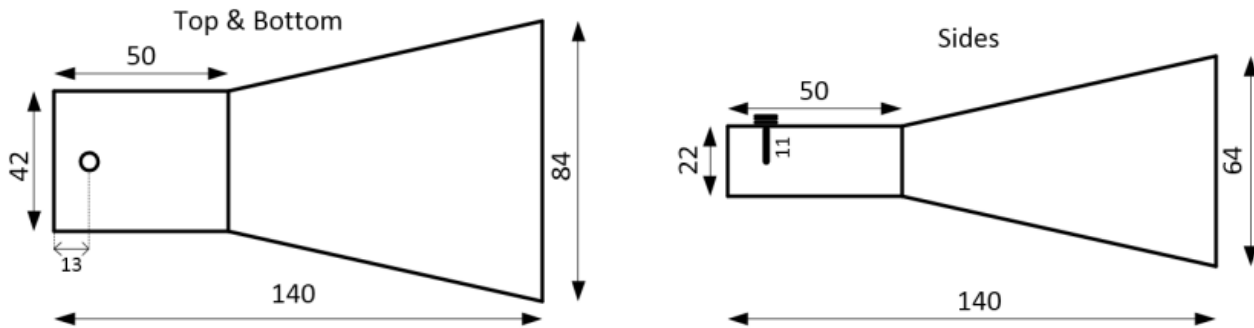

For the given dimensions in figures above, the gain of the pyramidal horn antenna is 12dB, the horizontal 3dB beamwidth is  $50^\circ$ , and the vertical 3dB beamwidth is  $62^\circ$ . The isolation between two horn antennas placed side-by-side in horizontal plane, is better than 70dB.

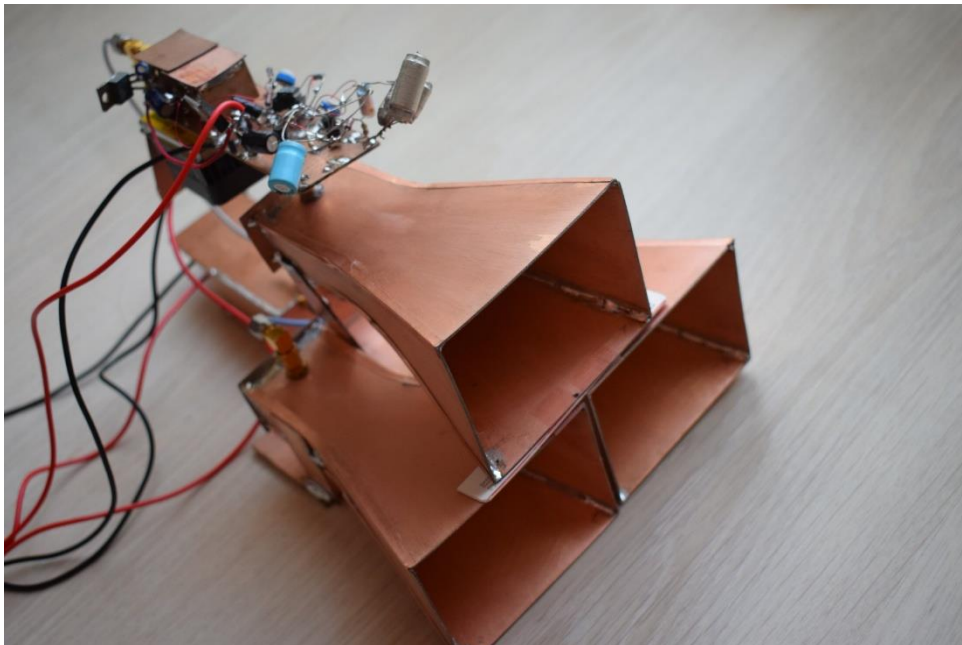

Prototype of the 5.6GHz FMCW Radar using Pyramidal Horn Antennas

## RCS (Radar Cross-Section)

RCS (radar cross-section) is the electromagnetic signature of an object. It represents the amount of energy reflected by the object when it is illuminated by a radar.

- The more detectable the object is, the higher the RCS.

Measurement of an object's RCS takes place at a radar reflectivity range. It can be an outdoor far-field range, or the measurements can be performed in an anechoic chamber.

Factors that influence Radar-Cross-Section RCS are:

- the material with which the target is made.
- the size of the target relative to the wavelength of the illuminating radar signal.
- the absolute size of the target.
- the incident angle (angle at which the radar beam hits a particular portion of the target, which depends upon the shape of the target and its orientation to the radar source).
- the reflected angle (angle at which the reflected beam leaves the part of the target hit; it depends upon incident angle).
- the polarization of the transmitted and the received radiation with respect to the orientation of the target.

## Corner Reflector

To measure the performances of the FMCW radar were built two trihedral corner reflectors using aluminum sheet, with dimension  $a = 30\text{cm}$ .

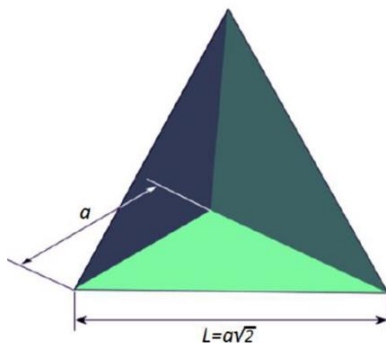

Corner Reflectors

- Corner Reflector is a structure that is used as a radar target, for measurements or calibration of the radar system.
- Corner Reflectors are used for many reasons: they have very high radar-cross-section (RCS) for a small size, the high RCS is maintained over a wide incidence angle, and an exact and stable solution is known for their RCS.

The cross-section area  $\sigma$  in  $\text{m}^2$  for **trihedral corner reflectors** using triangular shapes (as the one presented in the figures above), is given by:

$$\sigma = (4\pi a^4)/(3\lambda^2) \quad (13)$$

- For a corner reflector with dimension “ $a$ ” of 30cm (0.3m), at 6GHz ( $\lambda=5\text{cm}=0.05\text{m}$ ), we get a cross-section area of  $13.5\text{m}^2$ .
  - Therefore, in a radar system, for a target having the visual area of  $0.77\text{m}^2$ , we get a radar echo signal as would have been reflected by a  $13.5\text{m}^2$  target.
- To get a high cross-section area from a corner reflector, the dimension “ $a$ ” should be many times greater than the wavelength.
- Should be noted that according to the cross-section equation (13), if doubling the dimension “ $a$ ” of the corner reflector, the cross-section area will be 16 times greater.

Using Matlab, for a stationary corner reflector placed at various distances and angles from the source (2.1m/-35° and 3.3m/20°), was analyzed the received signal reflected from the target. See the picture below for the targets positions. Reflections due to grating lobes of the two receiving horn antennas (because distance between them is  $> \lambda/2$ ) is also shown in the picture.

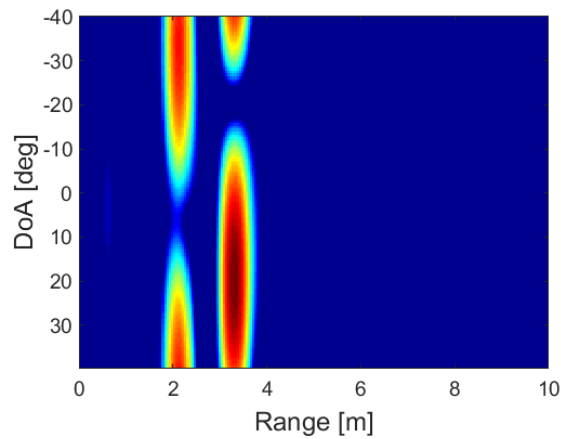

Range-angle representation of two targets placed at 2.1m/-35° respectively at 3.3m/20°

### Schematic of the C-Band, 5.6GHz, FMCW Radar

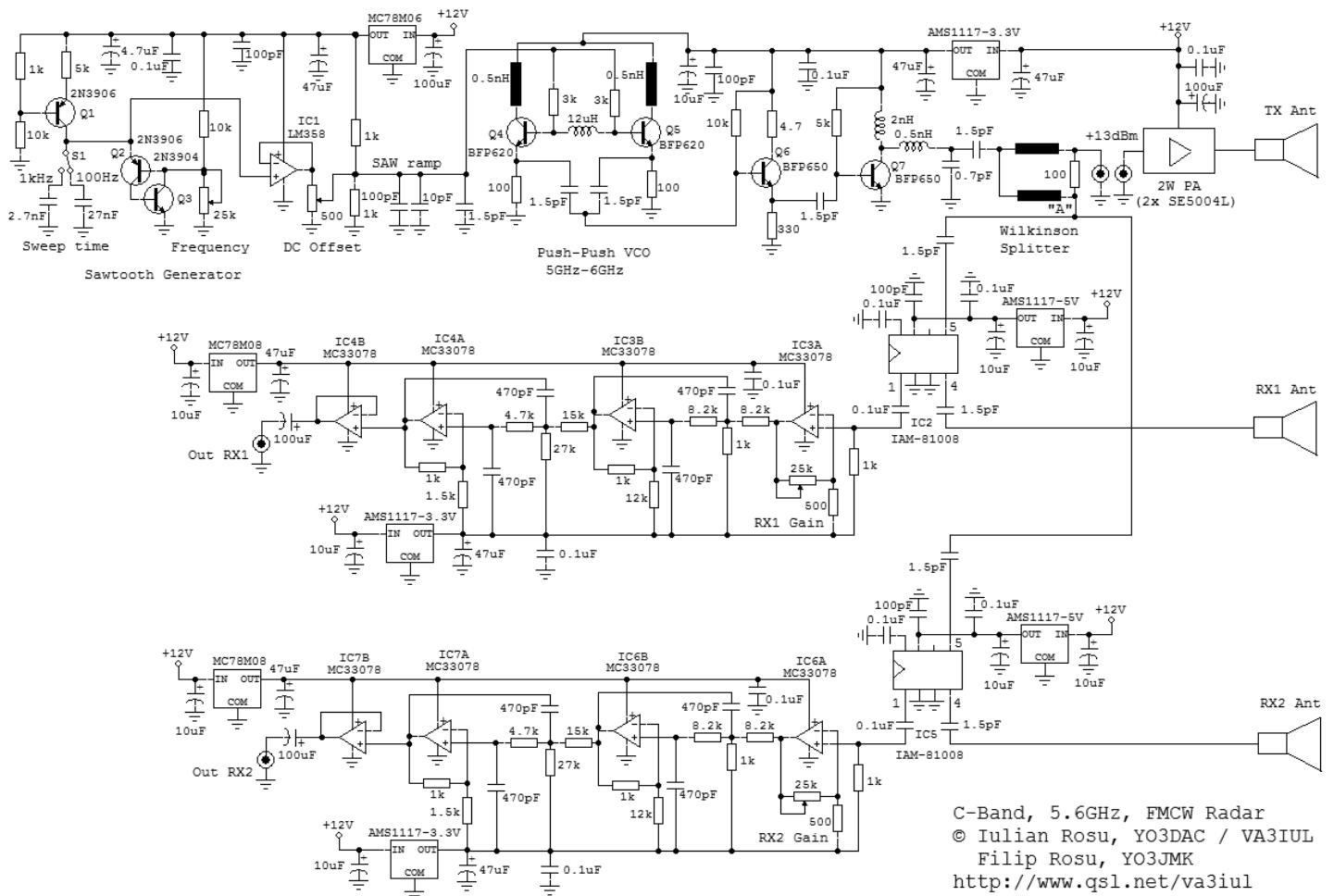

## References:

1. Automotive Radar - Chirp Analysis with R&S RTP Oscilloscope – R&S
2. Small and Short-Range Radar Systems – Charvat
3. RF and Microwave Transistor Oscillator Design – Grebennikov
4. Antenna Theory - Analysis and Design – Balanis
5. Introduction to mmWave Sensing: FMCW Radars – Rao - TI