

Technician License Course

Chapter 3

Lesson Plan Module 6 – Electrical Components



ARRL *The national association for
AMATEUR RADIO*

Electronics – Controlling the Flow of Current

- To make an electronic device (like a radio) do something useful (like a receiver), we need to control and manipulate the flow of current.
- There are a number of different electronic components that are used to do this.

Schematic Diagrams

- We can draw pictures of electronic components forming circuits, such as for the parallel and series circuit examples. This is too cumbersome for most circuits.
- Schematic diagrams use symbols with different components, each having a different symbol.

Schematic Diagrams

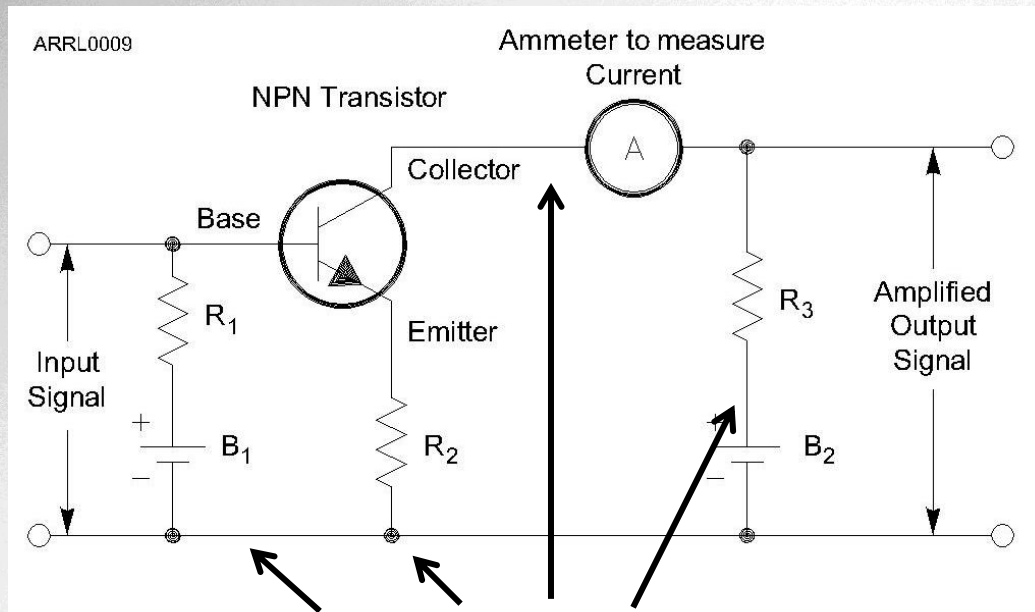

The lines and dots on schematics represent electrical connections between the components.



The Resistor

- The function of a resistor is to restrict the flow of current.
- Remember Ohm's Law:

$$I = E / R$$

$$E = I \times R$$

- Schematic symbol

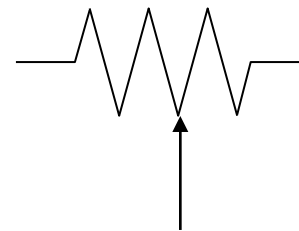
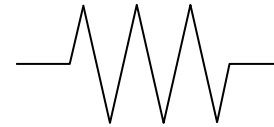

Potentiometer
or "Pot"

Arrow indicates adjustable value,
such as for a volume control.

The Capacitor

- The function of a capacitor is to store electrical energy – called *capacitance*.
 - Acts like a battery
 - Stores energy in an electric field created by voltage between the electrodes with insulating *dielectric* material between them

- Schematic symbol

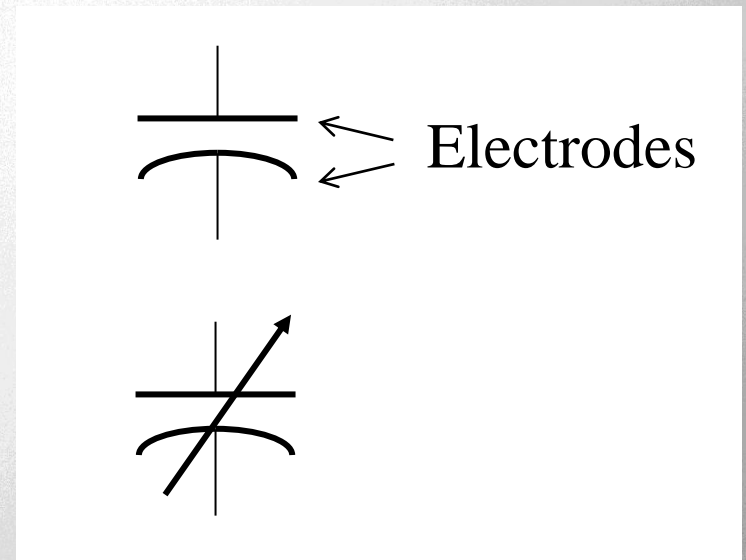

The Inductor

- The function of an inductor is to store magnetic energy – called *inductance*.
 - A coil of wire around a *core* of air or magnetic material like iron or ferrite
 - Stores energy in a magnetic field created by current in the wire
- Schematic symbol

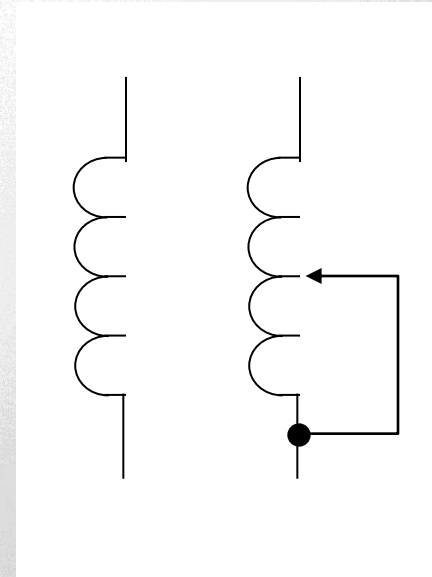

The Transformer

- A pair of inductors sharing a common core
 - Also share their magnetic field
 - Used to transfer energy from one circuit to another without a direct connection
 - Changes the ratio of voltage and current
- Schematic symbol

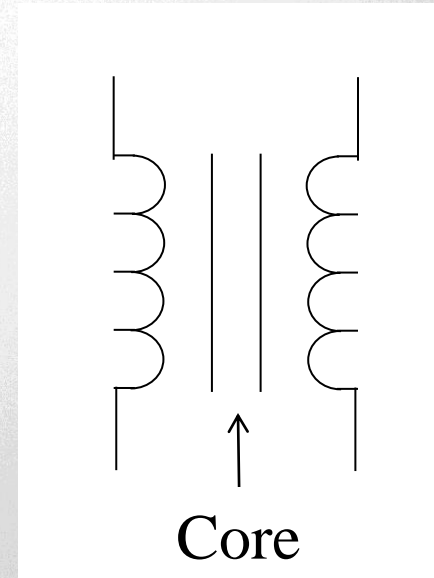

Electrical Units

- Each type of component has a value measured in specific units:
 - Resistors > resistance > ohms (Ω)
 - Capacitors > capacitance > farads (F)
 - Inductors > inductance > henrys (H)

Component Designators

- Each schematic symbol has a *designator* to denote which component it refers to. For example, the 10th resistor in a circuit is R10.
- Resistors (R), capacitors (C), inductors (L).

Indicators and Displays

- Indicators communicate status
 - ON/OFF, ready/stand-by, left/right
 - LEDs, light bulbs, symbols, audio tones
- Displays communicate values or text
 - Numeric values, warnings, messages
 - Digital and analog meters, LCD screens

Reactance

- Capacitors and inductors store energy, rather than dissipating it like resistors.
- Energy storage creates an effect called *reactance* (symbol X) that acts like a resistance in opposing the flow of ac current.
 - Capacitors create *capacitive reactance* (X_C)
 - Inductors create *inductive reactance* (X_L)
 - The effects of each are complementary

Impedance

- The combination of resistance (R) and reactance (X) is called *impedance*, represented by the symbol Z .
- Impedance represents a circuit's opposition to both ac and dc currents.

Resonance

- A component's reactance depends on frequency: X_L increases with frequency while X_C decreases.
- At the frequency for which a circuit's X_L and X_C are equal, their effects cancel. This is the circuit's *resonant frequency*.
- At *resonance*, a circuit has only resistance, which affects ac and dc current equally.

Resonant or Tuned Circuit

- Capacitors and inductors connected together create a *tuned circuit*.
 - When X_L and X_C are equal, the circuit is *resonant*.
 - If C or L are adjustable the resonant frequency can be varied or tuned.

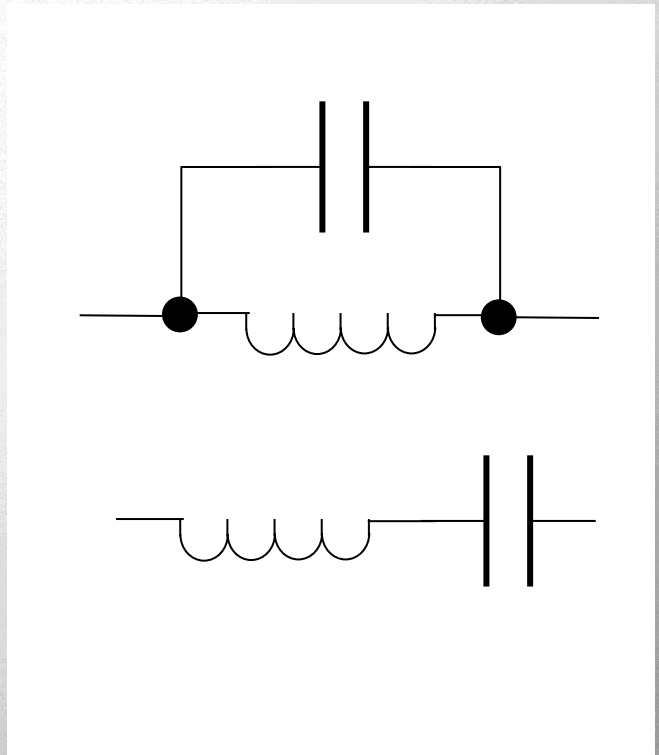

ARRL The national association for
AMATEUR RADIO

Semiconductor Components

- Made of material like silicon that are “OK” conductors but not as good as metals.
- Impurities added to semiconductors create material with more than usual electrons (*N-type*) and fewer than usual (*P-type*) electrons.
- Structures of N and P material can control current flow through the semiconductor.

The Diode

- Allows current to flow in only one direction.
 - Two electrodes: *anode* and *cathode*
 - AC current is changed to varying pulses of dc – called *rectification*
 - Diodes used to change ac power to dc power are called *rectifiers*
- Schematic symbol
- Designator (D or CR)

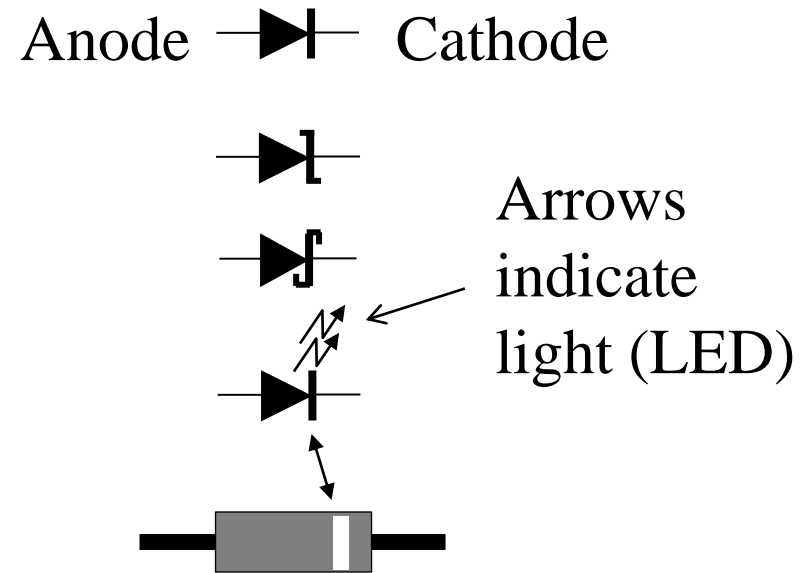

The Transistor

- The function of a transistor is to control large signals with small ones.
 - An “electronically controlled current valve”
 - When used as an amplifier a transistor produces *gain*
 - Transistors can also be used as a switch

- Schematic symbol
- Designator (Q)

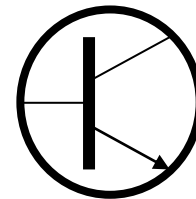

Bipolar
Junction
Transistor (BJT)

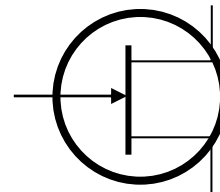

Field-Effect
Transistor (FET)



The Transistor

- The Bipolar Junction Transistor (BJT) has three layers of N or P material connected to electrodes:

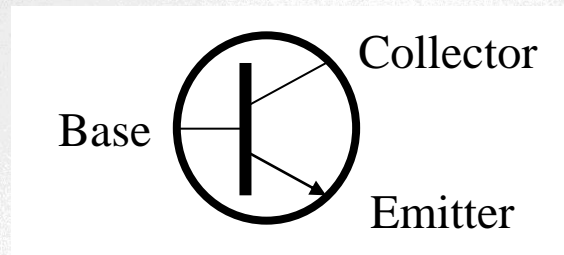

- Depending on the arrangement of layers, a BJT is either an NPN or PNP transistor.

The Transistor

- The Field-Effect Transistor (FET) has a conducting path or channel of N and P material connected to the drain and source electrodes.

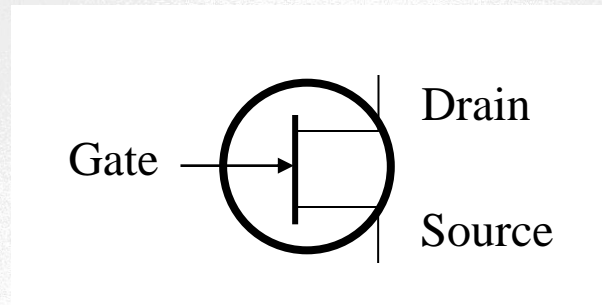

- Voltage applied to the gate electrode controls current through the channel.

The Integrated Circuit

- The integrated circuit is a collection of components contained in one device that accomplishes a specific task.
- Schematic symbol
- Designator (IC or U)

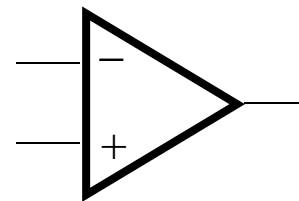
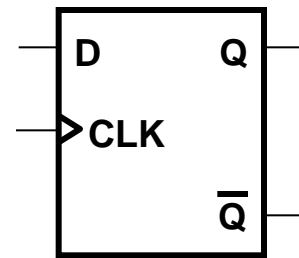

Protective Components

- Fuses and circuit breakers are designed to remove power in case of a circuit overload.
 - Fuses blow – one time protection
 - Circuit breakers trip – can be reset and reused
 - Always use proper rating

- Schematic symbol
- Designator (F or CB)



Fuses



Circuit
Breaker



Switches

- Switches are used to interrupt or allow current to flow.
 - Each circuit controlled by the switch is a *pole*
 - Each position is called a *throw*
- Schematic symbol
- Designator (S or SW)

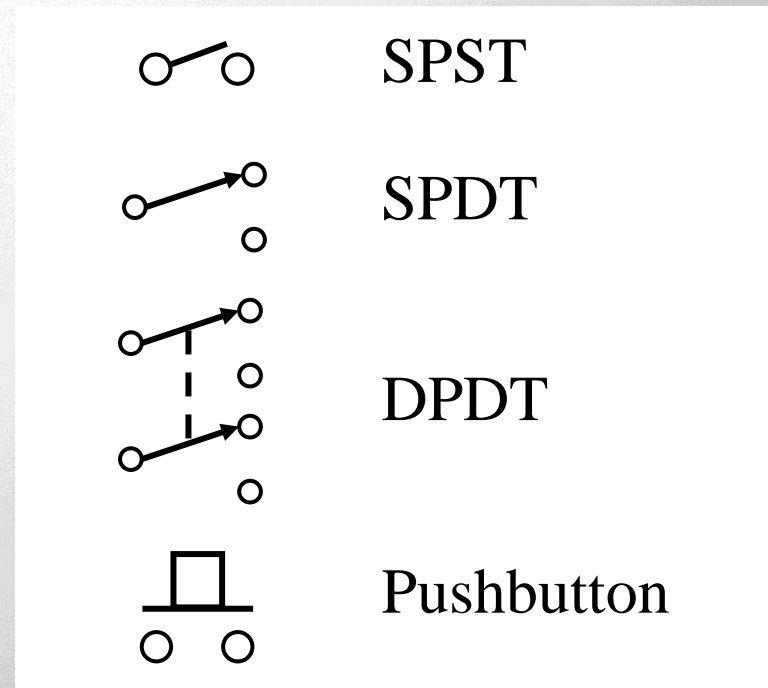

Relays

- Relays are switches activated by current in a coil (electromagnet)
- Relays use the same pole/throw names as switches
- The moving switch is called the *armature*
- *Contacts* are named by when they are connected
- Schematic symbol
- Designator (K or RLY)

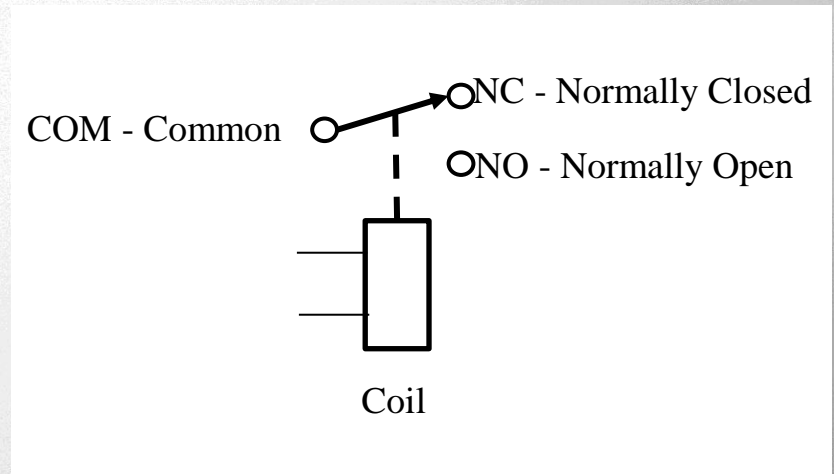

Other Circuit Symbols

Schematic Symbols Used in Circuit Diagrams

Labelling conventions: # is a sequential number. (X#) is the component designator. Examples - C3, L11, R8, Q3

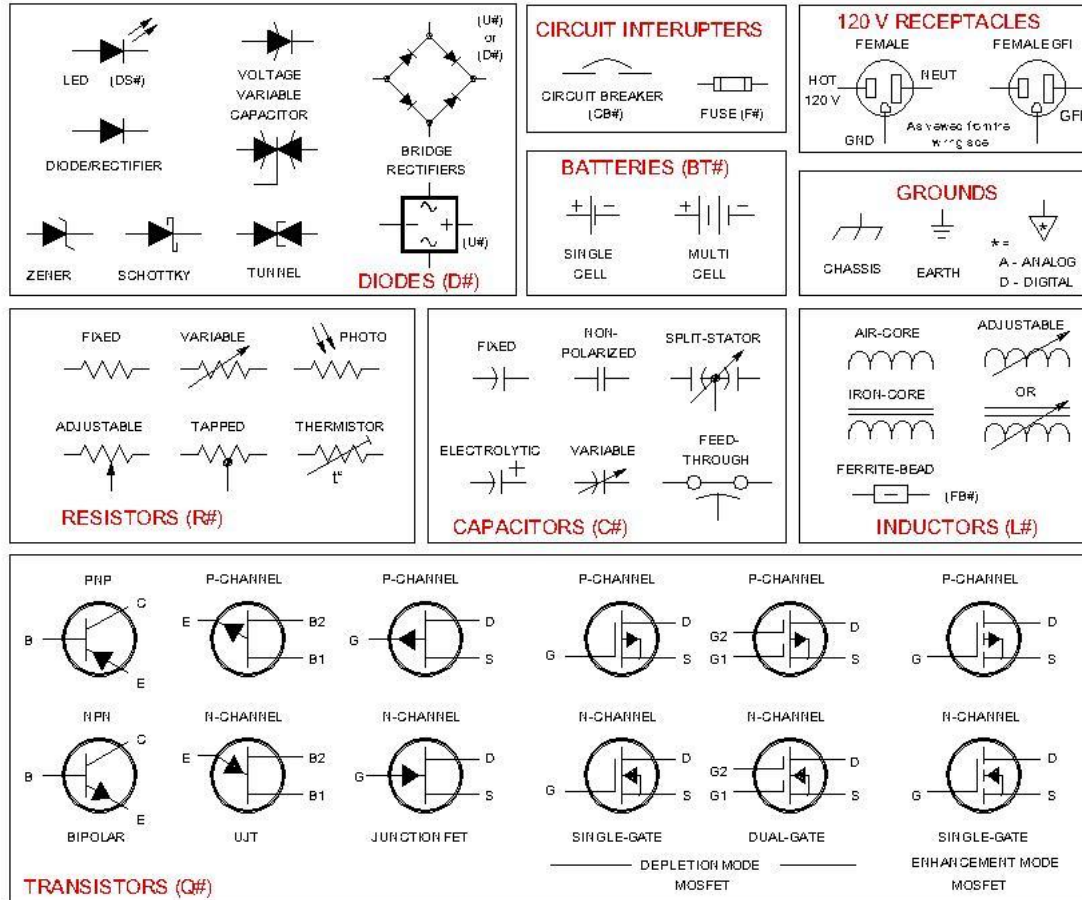

8-11-84 by 1106 8/82



ARRL The national association for AMATEUR RADIO

Practice Questions



What is the ability to store energy in an electric field called?

- A. Inductance
- B. Resistance
- C. Tolerance
- D. Capacitance

T5C01 HRLM (3-7)



What is the ability to store energy in an electric field called?

- A. Inductance
- B. Resistance
- C. Tolerance
- D. Capacitance**

T5C01 HRLM (3-7)



What is the basic unit of capacitance?

- A. The farad
- B. The ohm
- C. The volt
- D. The henry

T5C02 HRLM (3-7)

What is the basic unit of capacitance?

- A. The farad
- B. The ohm
- C. The volt
- D. The henry

T5C02 HRLM (3-7)

What is the ability to store energy in a magnetic field called?

- A. Admittance
- B. Capacitance
- C. Resistance
- D. Inductance

T5C03 HRLM (3-7)



What is the ability to store energy in a magnetic field called?

- A. Admittance
- B. Capacitance
- C. Resistance
- D. Inductance**

T5C03 HRLM (3-7)



What is the basic unit of inductance?

- A. The coulomb
- B. The farad
- C. The henry
- D. The ohm

T5C04 HRLM (3-7)

What is the basic unit of inductance?

- A. The coulomb
- B. The farad
- C. The henry**
- D. The ohm

T5C04 HRLM (3-7)

What is meant by the term impedance?

- A. It is a measure of the opposition to AC current flow in a circuit
- B. It is the inverse of resistance
- C. It is a measure of the Q or Quality Factor of a component
- D. It is a measure of the power handling capability of a component

T5C12 HRLM (3-9)

What is meant by the term impedance?

- A. It is a measure of the opposition to AC current flow in a circuit**
- B. It is the inverse of resistance
- C. It is a measure of the Q or Quality Factor of a component
- D. It is a measure of the power handling capability of a component

T5C12 HRLM (3-9)

What are the units of impedance?

- A. Volts
- B. Amperes
- C. Coulombs
- D. Ohms

T5C13 HRLM (3-9)

What are the units of impedance?

- A. Volts
- B. Amperes
- C. Coulombs
- D. Ohms**

T5C13 HRLM (3-9)



What electrical component is used to oppose the flow of current in a DC circuit?

- A. Inductor
- B. Resistor
- C. Voltmeter
- D. Transformer

T6A01 HRLM (3-7)



What electrical component is used to oppose the flow of current in a DC circuit?

- A. Inductor
- B. Resistor**
- C. Voltmeter
- D. Transformer

T6A01 HRLM (3-7)



What type of component is often used as an adjustable volume control?

- A. Fixed resistor
- B. Power resistor
- C. Potentiometer
- D. Transformer

T6A02 HRLM (3-9)



What type of component is often used as an adjustable volume control?

- A. Fixed resistor
- B. Power resistor
- C. Potentiometer**
- D. Transformer

T6A02 HRLM (3-9)



What electrical parameter is controlled by a potentiometer?

- A. Inductance
- B. Resistance
- C. Capacitance
- D. Field strength

T6A03 HRLM (3-9)

What electrical parameter is controlled by a potentiometer?

- A. Inductance
- B. Resistance**
- C. Capacitance
- D. Field strength

T6A03 HRLM (3-9)

What electrical component stores energy in an electric field?

- A. Resistor
- B. Capacitor
- C. Inductor
- D. Diode

T6A04 HRLM (3-7)

What electrical component stores energy in an electric field?

- A. Resistor
- B. Capacitor**
- C. Inductor
- D. Diode

T6A04 HRLM (3-7)

What type of electrical component consists of two or more conductive surfaces separated by an insulator?

- A. Resistor
- B. Potentiometer
- C. Oscillator
- D. Capacitor

T6A05 HRLM (3-7)



What type of electrical component consists of two or more conductive surfaces separated by an insulator?

- A. Resistor
- B. Potentiometer
- C. Oscillator
- D. Capacitor**

T6A05 HRLM (3-7)



What type of electrical component stores energy in a magnetic field?

- A. Resistor
- B. Capacitor
- C. Inductor
- D. Diode

T6A06 HRLM (3-7)



What type of electrical component stores energy in a magnetic field?

- A. Resistor
- B. Capacitor
- C. Inductor**
- D. Diode

T6A06 HRLM (3-7)



What electrical component is usually composed of a coil of wire?

- A. Switch
- B. Capacitor
- C. Diode
- D. Inductor

T6A07 HRLM (3-7)



What electrical component is usually composed of a coil of wire?

- A. Switch
- B. Capacitor
- C. Diode
- D. Inductor**

T6A07 HRLM (3-7)



What electrical component is used to connect or disconnect electrical circuits?

- A. Magnetron
- B. Switch
- C. Thermistor
- D. All of these choices are correct

T6A08 HRLM (3-12)



What electrical component is used to connect or disconnect electrical circuits?

- A. Magnetron
- B. Switch**
- C. Thermistor
- D. All of these choices are correct

T6A08 HRLM (3-12)



What electrical component is used to protect other circuit components from current overloads?

- A. Fuse
- B. Capacitor
- C. Inductor
- D. All of these choices are correct

T6A09 HRLM (3-12)



What electrical component is used to protect other circuit components from current overloads?

- A. Fuse
- B. Capacitor
- C. Inductor
- D. All of these choices are correct

T6A09 HRLM (3-12)



What class of electronic components is capable of using a voltage or current signal to control current flow?

- A. Capacitors
- B. Inductors
- C. Resistors
- D. Transistors

T6B01 HRLM (3-11)



What class of electronic components is capable of using a voltage or current signal to control current flow?

- A. Capacitors
- B. Inductors
- C. Resistors
- D. Transistors**

T6B01 HRLM (3-11)



What electronic component allows current to flow in only one direction?

- A. Resistor
- B. Fuse
- C. Diode
- D. Driven Element

T6B02 HRLM (3-10)



What electronic component allows current to flow in only one direction?

- A. Resistor
- B. Fuse
- C. Diode**
- D. Driven Element

T6B02 HRLM (3-10)



Which of these components can be used as an electronic switch or amplifier?

- A. Oscillator
- B. Potentiometer
- C. Transistor
- D. Voltmeter

T6B03 HRLM (3-11)



Which of these components can be used as an electronic switch or amplifier?

- A. Oscillator
- B. Potentiometer
- C. Transistor**
- D. Voltmeter

T6B03 HRLM (3-11)



Which of the following components can be made of three layers of semiconductor material?

- A. Alternator
- B. Transistor
- C. Triode
- D. Pentagrid converter

T6B04 HRLM (3-11)



Which of the following components can be made of three layers of semiconductor material?

- A. Alternator
- B. Transistor**
- C. Triode
- D. Pentagrid converter

T6B04 HRLM (3-11)



Which of the following electronic components can amplify signals?

- A. Transistor
- B. Variable resistor
- C. Electrolytic capacitor
- D. Multi-cell battery

T6B05 HRLM (3-11)

Which of the following electronic components can amplify signals?

- A. Transistor
- B. Variable resistor
- C. Electrolytic capacitor
- D. Multi-cell battery

T6B05 HRLM (3-11)

How is the cathode lead of a semiconductor diode usually identified?

- A. With the word "cathode"
- B. With a stripe
- C. With the letter "C"
- D. All of these choices are correct

T6B06 HRLM (3-10)

How is the cathode lead of a semiconductor diode usually identified?

- A. With the word "cathode"
- B. With a stripe**
- C. With the letter "C"
- D. All of these choices are correct

T6B06 HRLM (3-10)

What does the abbreviation LED stand for?

- A. Low Emission Diode
- B. Light Emitting Diode
- C. Liquid Emission Detector
- D. Long Echo Delay

T6B07 HRLM (3-10)



What does the abbreviation LED stand for?

- A. Low Emission Diode
- B. Light Emitting Diode**
- C. Liquid Emission Detector
- D. Long Echo Delay

T6B07 HRLM (3-10)



What does the abbreviation FET stand for?

- A. Field Effect Transistor
- B. Fast Electron Transistor
- C. Free Electron Transition
- D. Field Emission Thickness

T6B08 HRLM (3-11)



What does the abbreviation FET stand for?

- A. **Field Effect Transistor**
- B. Fast Electron Transistor
- C. Free Electron Transition
- D. Field Emission Thickness

T6B08 HRLM (3-11)



What are the names of the two electrodes of a diode?

- A. Plus and minus
- B. Source and drain
- C. Anode and cathode
- D. Gate and base

T6B09 HRLM (3-10)

What are the names of the two electrodes of a diode?

- A. Plus and minus
- B. Source and drain
- C. Anode and cathode**
- D. Gate and base

T6B09 HRLM (3-10)

What are the three electrodes of a PNP or NPN transistor?

- A. Emitter, base, and collector
- B. Source, gate, and drain
- C. Cathode, grid, and plate
- D. Cathode, drift cavity, and collector

T6B10 HRLM (3-11)

What are the three electrodes of a PNP or NPN transistor?

- A. Emitter, base, and collector**
- B. Source, gate, and drain
- C. Cathode, grid, and plate
- D. Cathode, drift cavity, and collector

T6B10 HRLM (3-11)

What are the three electrodes of a field effect transistor?

- A. Emitter, base, and collector
- B. Source, gate, and drain
- C. Cathode, grid, and plate
- D. Cathode, gate, and anode

T6B11 HRLM (3-11)

What are the three electrodes of a field effect transistor?

- A. Emitter, base, and collector
- B. Source, gate, and drain**
- C. Cathode, grid, and plate
- D. Cathode, gate, and anode

T6B11 HRLM (3-11)

What is the term that describes a transistor's ability to amplify a signal?

- A. Gain
- B. Forward resistance
- C. Forward voltage drop
- D. On resistance

T6B12 HRLM (3-11)



What is the term that describes a transistor's ability to amplify a signal?

- A. Gain
- B. Forward resistance
- C. Forward voltage drop
- D. On resistance

T6B12 HRLM (3-11)



What is the name for standardized representations of components in an electrical wiring diagram?

- A. Electrical depictions
- B. Grey sketch
- C. Schematic symbols
- D. Component callouts

T6C01 HRLM (3-13)



What is the name for standardized representations of components in an electrical wiring diagram?

- A. Electrical depictions
- B. Grey sketch
- C. Schematic symbols**
- D. Component callouts

T6C01 HRLM (3-13)



What is component 1 in figure T1?

- A. Resistor
- B. Transistor
- C. Battery
- D. Connector

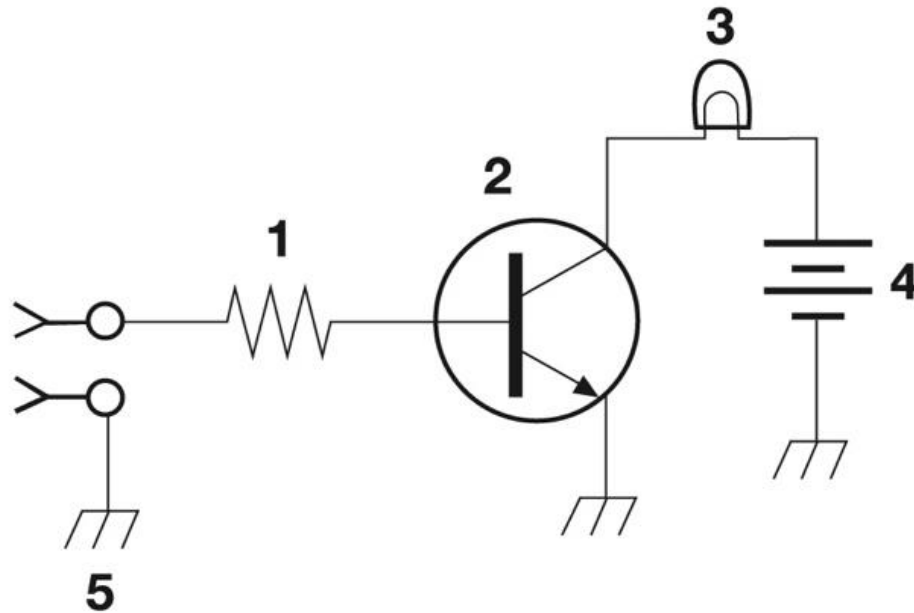

Figure T-1

What is component 1 in figure T1?

- A. Resistor
- B. Transistor
- C. Battery
- D. Connector

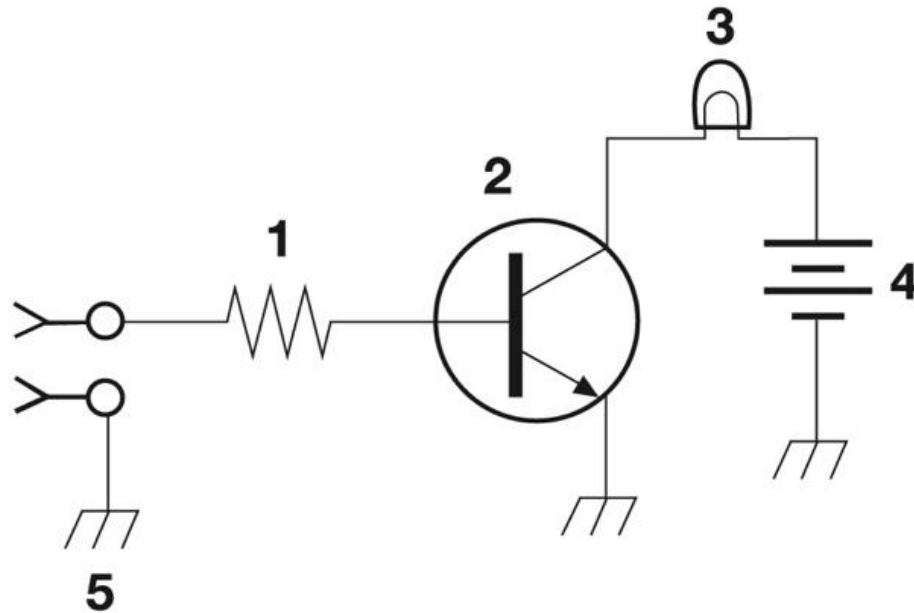

Figure T-1

What is component 2 in figure T1?

- A. Resistor
- B. Transistor
- C. Indicator lamp
- D. Connector

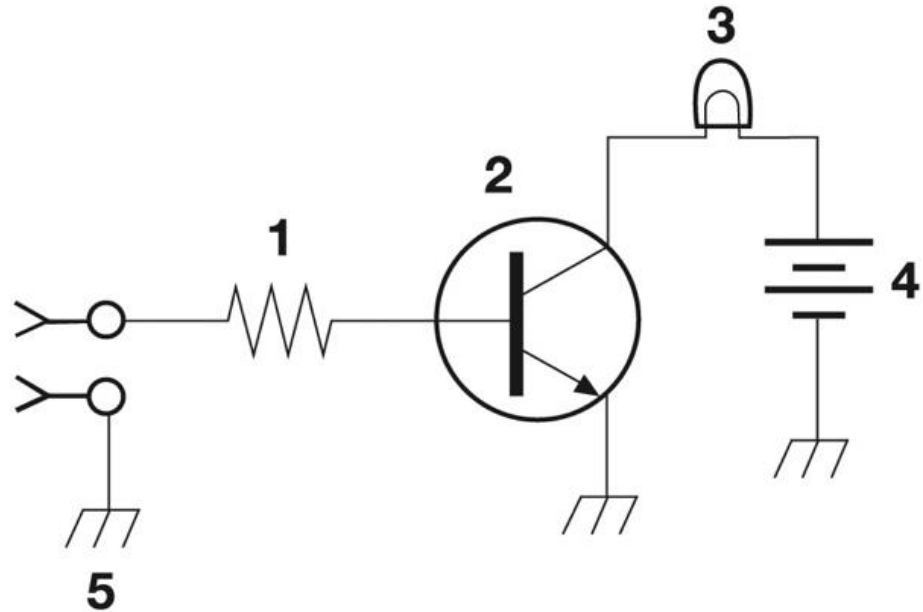

Figure T-1

What is component 2 in figure T1?

- A. Resistor
- B. Transistor**
- C. Indicator lamp
- D. Connector

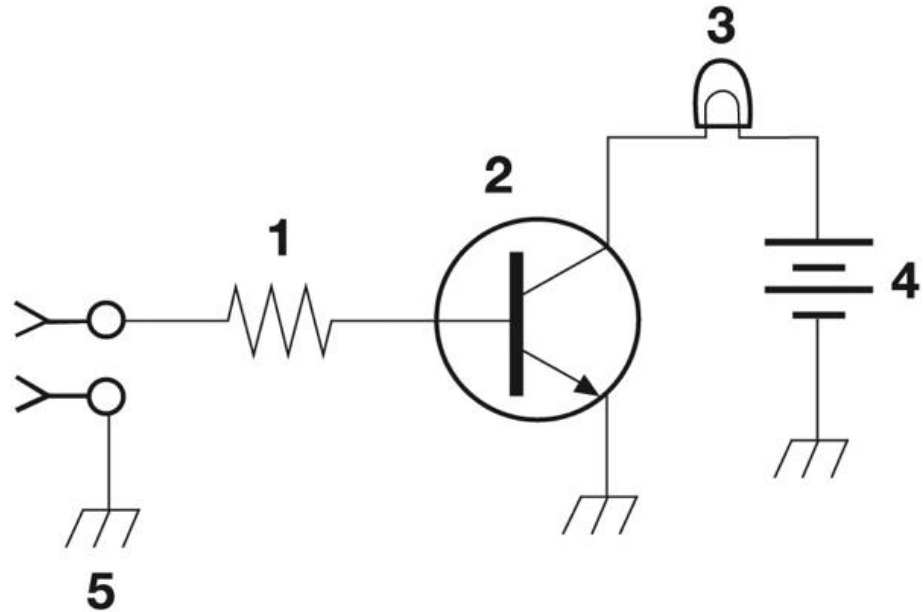

Figure T-1

What is component 3 in figure T1?

- A. Resistor
- B. Transistor
- C. Lamp
- D. Ground symbol

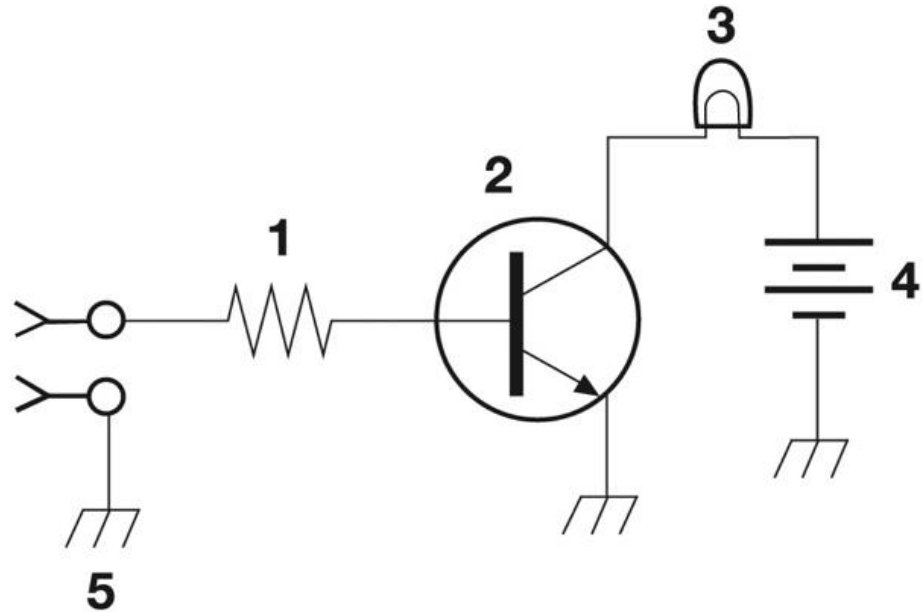

Figure T-1

What is component 3 in figure T1?

- A. Resistor
- B. Transistor
- C. Lamp**
- D. Ground symbol

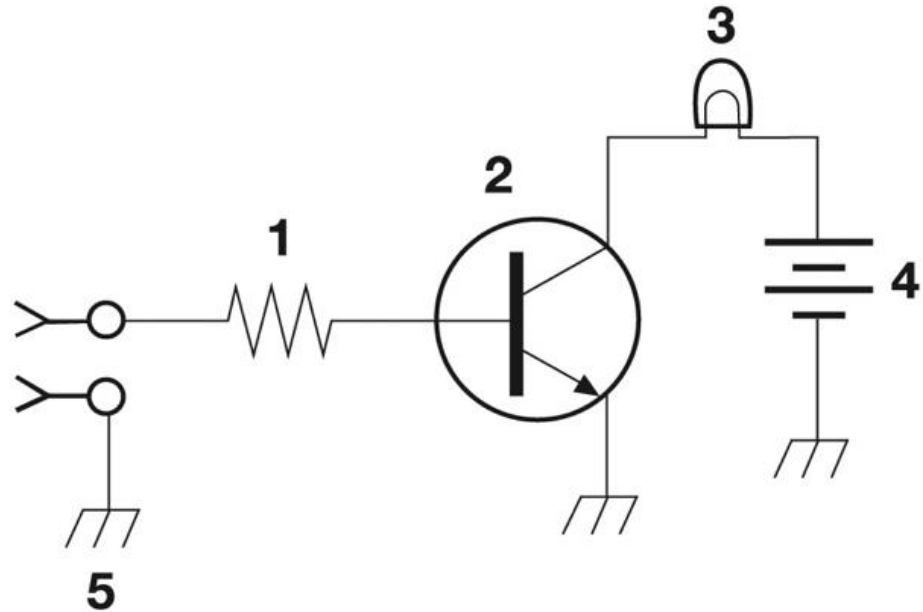

Figure T-1

What is component 4 in figure T1?

- A. Resistor
- B. Transistor
- C. Battery
- D. Ground symbol

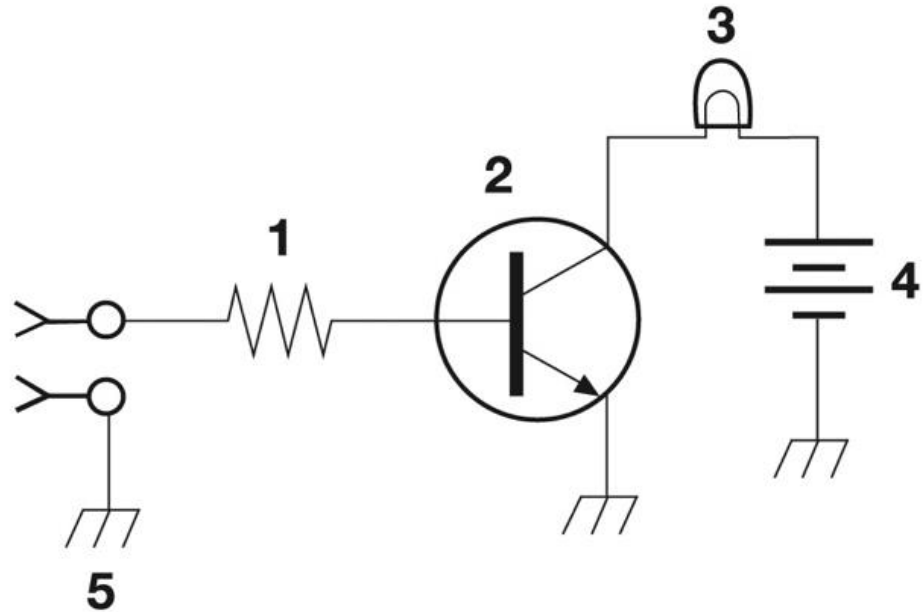

Figure T-1

What is component 4 in figure T1?

- A. Resistor
- B. Transistor
- C. Battery**
- D. Ground symbol

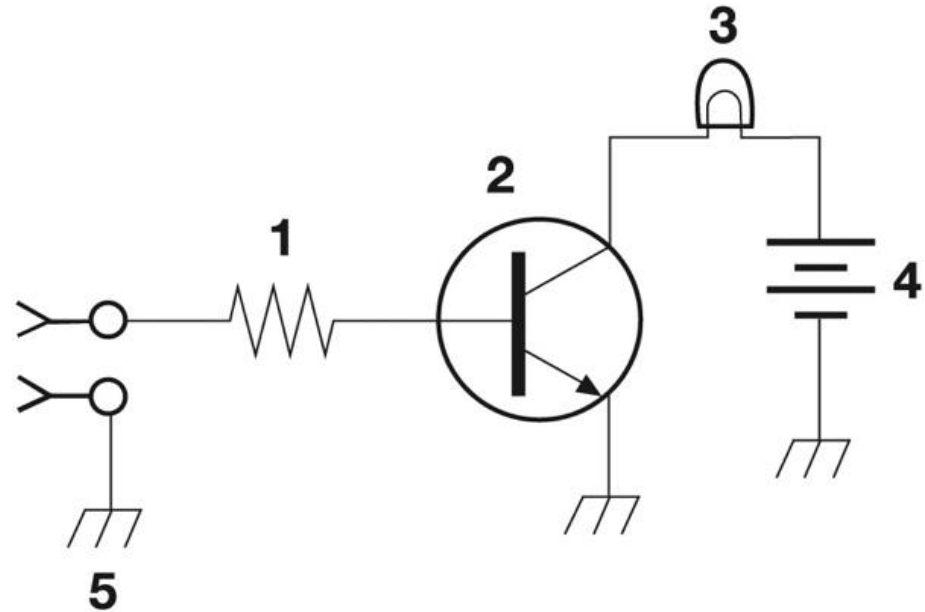

Figure T-1

What is component 6 in figure T2?

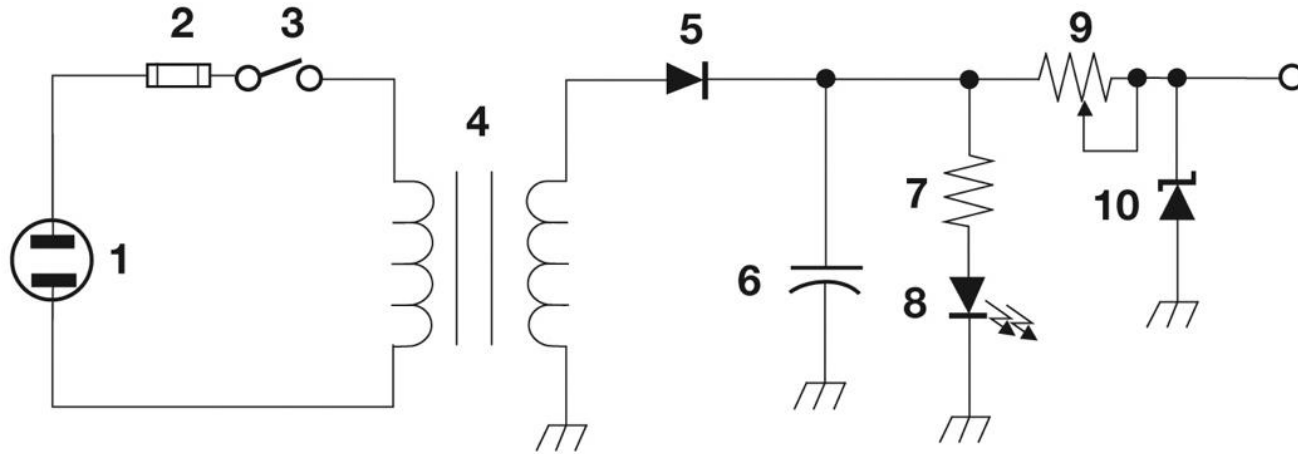

Figure T-2

- A. Resistor
- B. Capacitor

- C. Regulator IC
- D. Transistor

T6C06 HRLM (3-13)

What is component 6 in figure T2?

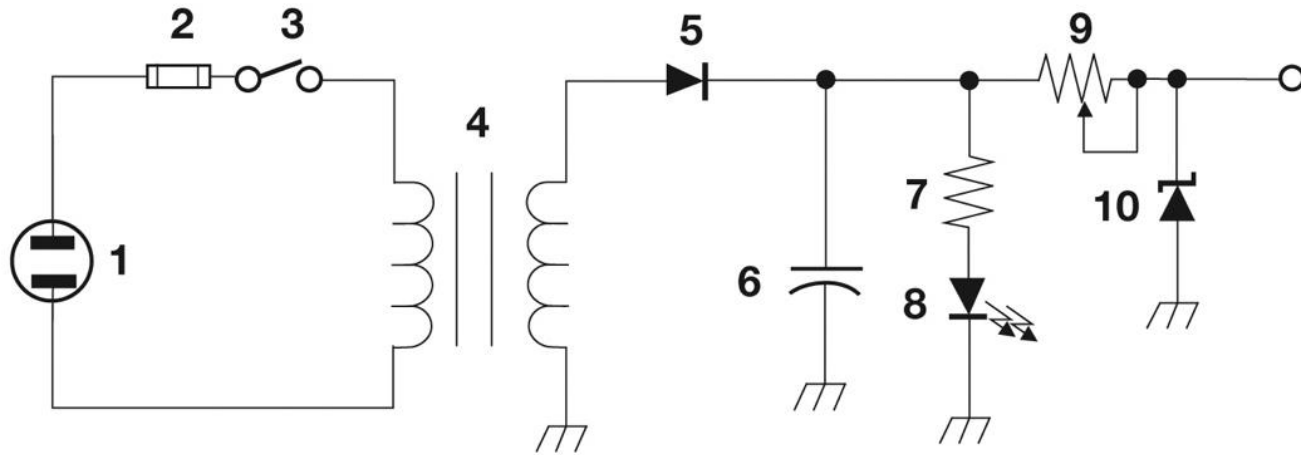

Figure T-2

A. Resistor

B. Capacitor

C. Regulator IC

D. Transistor

T6C06 HRLM (3-13)



ARRL The national association for
AMATEUR RADIO

What is component 8 in figure T2?

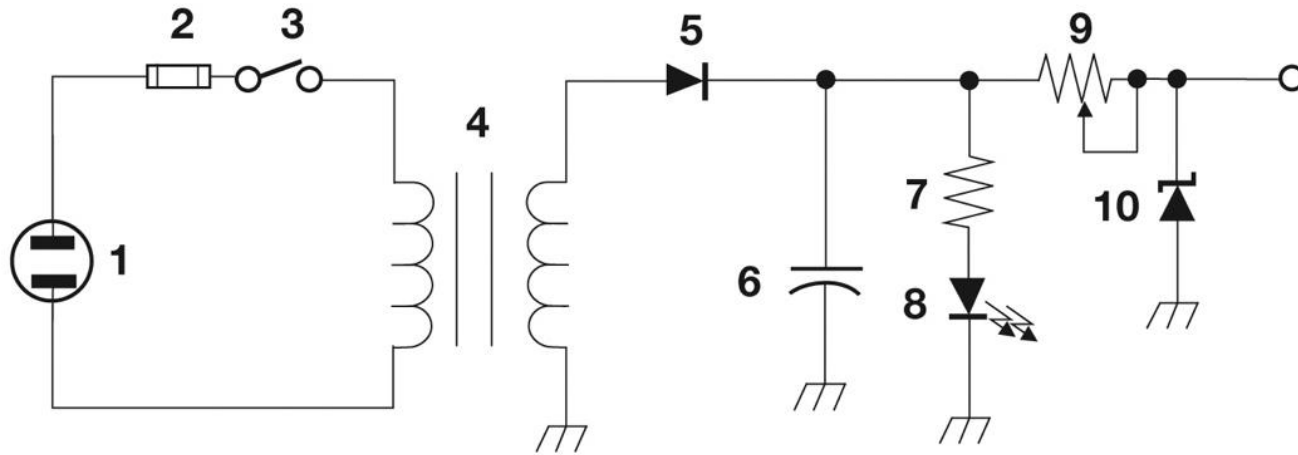

Figure T-2

- A. Resistor
- B. Inductor

- C. Regulator IC
- D. Light emitting diode

T6C07 HRLM (3-13)

What is component 8 in figure T2?

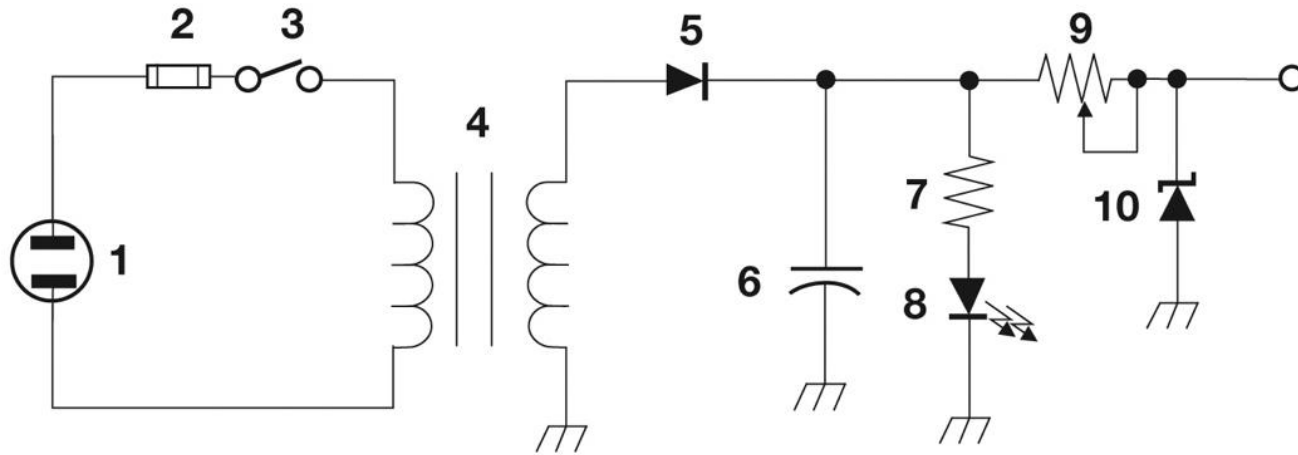

Figure T-2

- A. Resistor
- B. Inductor

- C. Regulator IC
- D. Light emitting diode**

T6C07 HRLM (3-13)

What is component 9 in figure T2?

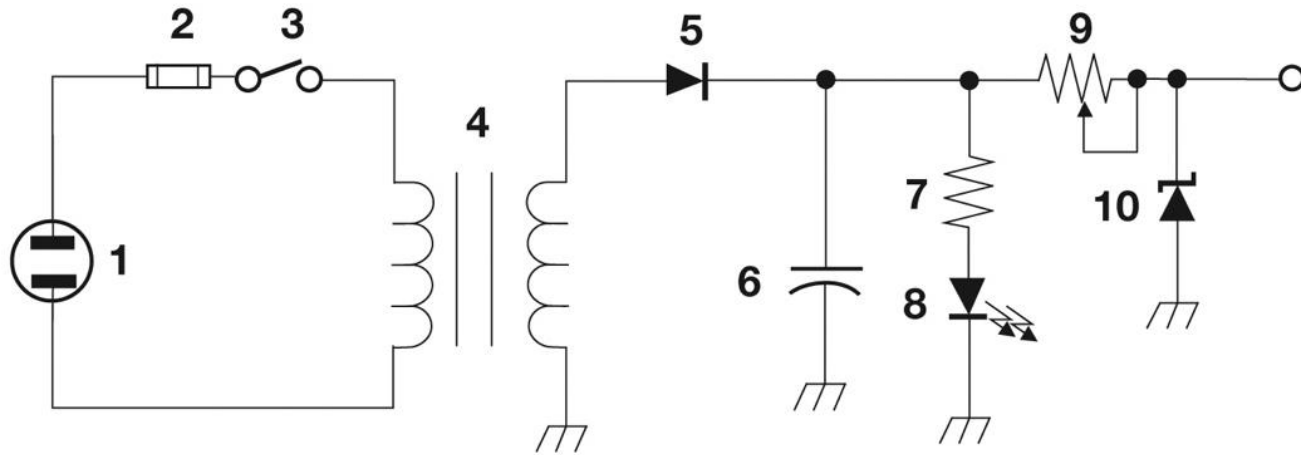

Figure T-2

- A. Variable capacitor
- B. Variable inductor
- C. Variable resistor
- D. Variable transformer

T6C08 HRLM (3-13)

What is component 9 in figure T2?

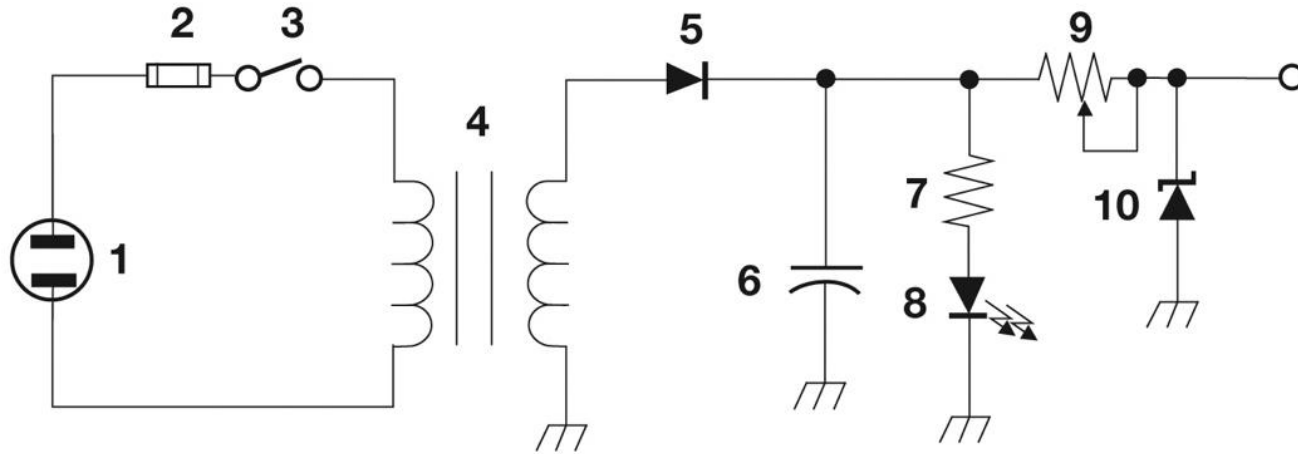

Figure T-2

A. Variable capacitor D. Variable transformer

B. Variable inductor

C. Variable resistor

T6C08 HRLM (3-13)



ARRL The national association for
AMATEUR RADIO

What is component 4 in figure T2?

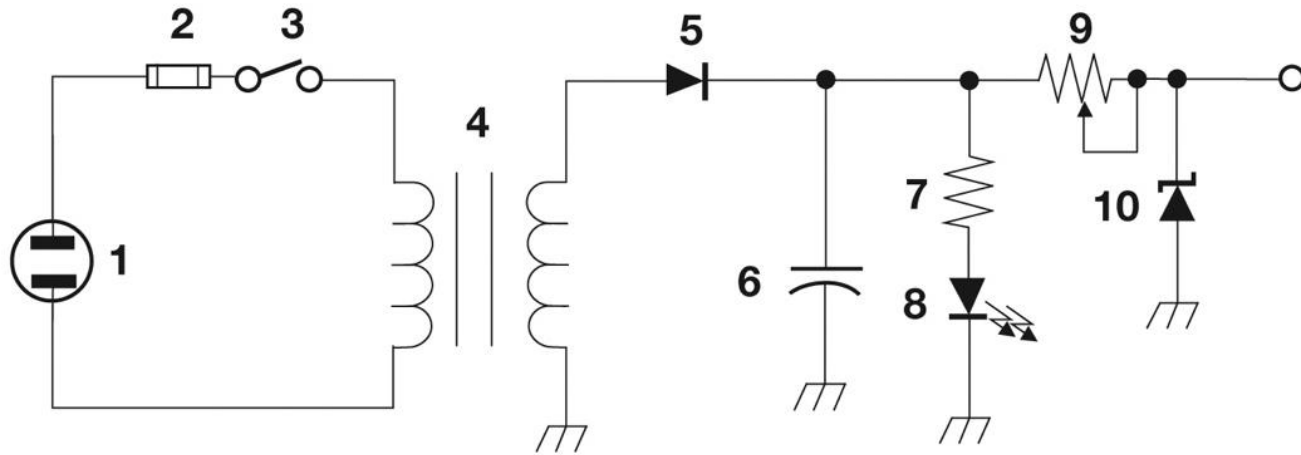

Figure T-2

- A. Variable inductor
- B. Double-pole switch
- C. Potentiometer
- D. Transformer

T6C09 HRLM (3-13)

What is component 4 in figure T2?

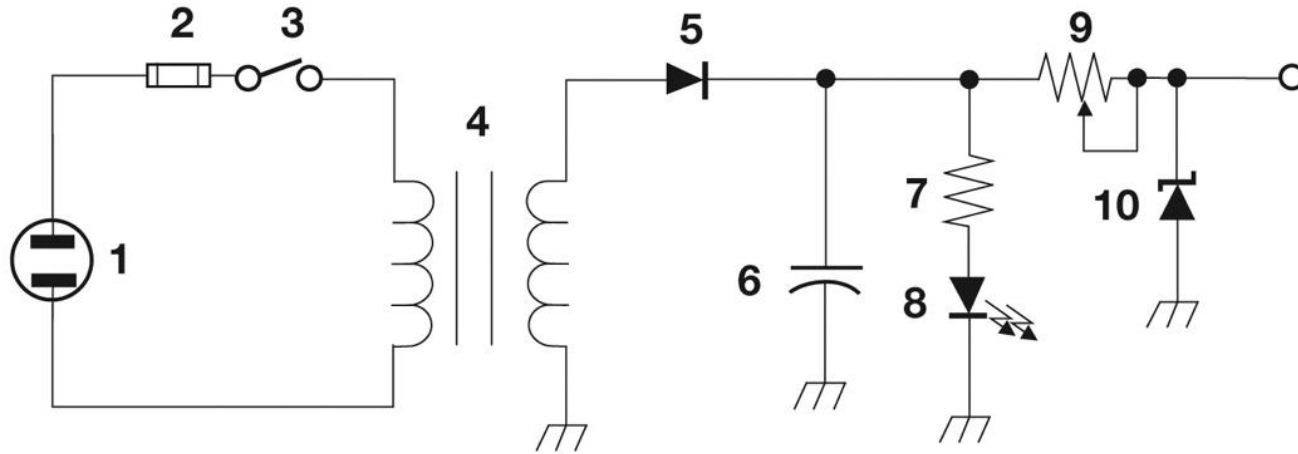

Figure T-2

- A. Variable inductor
- B. Double-pole switch
- C. Potentiometer
- D. Transformer**

T6C09 HRLM (3-13)

What is component 3 in figure T3?

- A. Connector
- B. Meter
- C. Variable capacitor
- D. Variable inductor

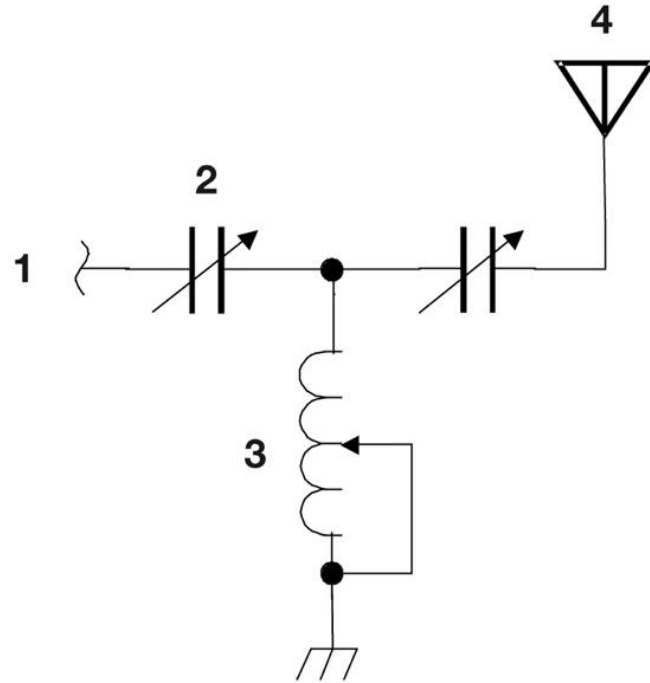

Figure T-3

T6C10 HRLM (3-13)

What is component 3 in figure T3?

- A. Connector
- B. Meter
- C. Variable capacitor
- D. Variable inductor**

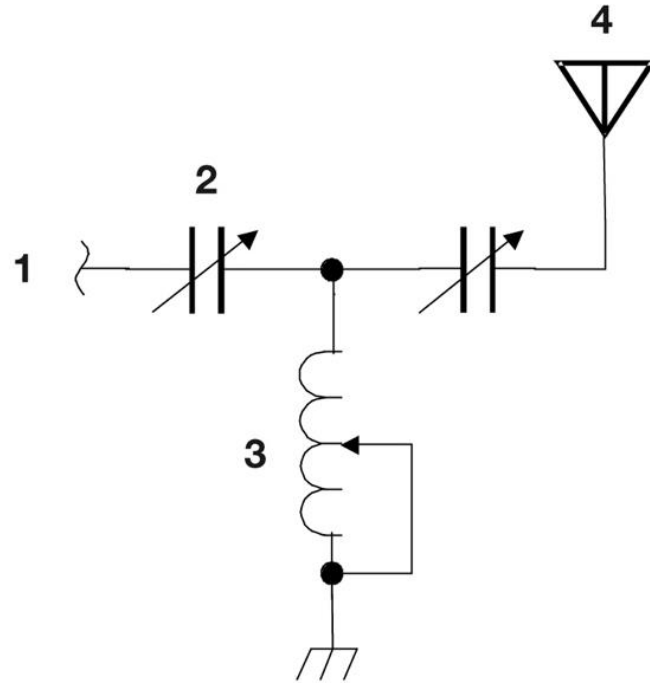

Figure T-3

What is component 4 in figure T3?

- A. Antenna
- B. Transmitter
- C. Dummy load
- D. Ground

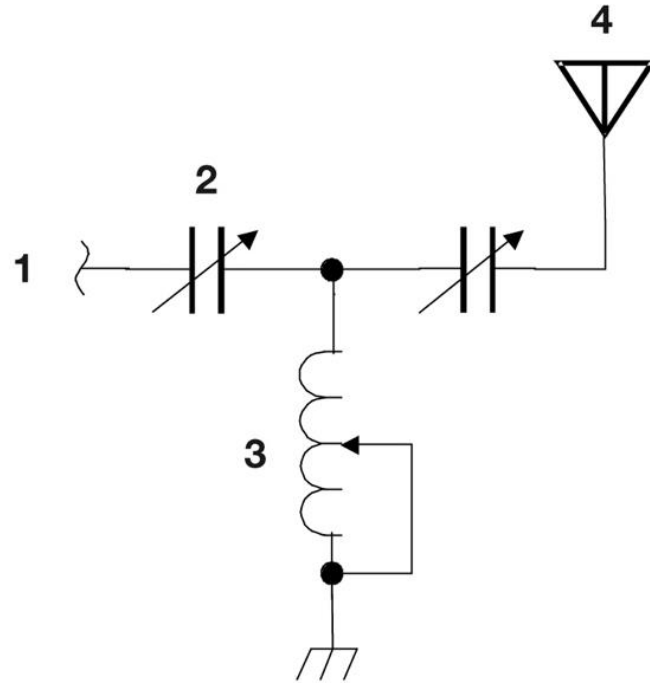

Figure T-3

What is component 4 in figure T3?

- A. Antenna
- B. Transmitter
- C. Dummy load
- D. Ground

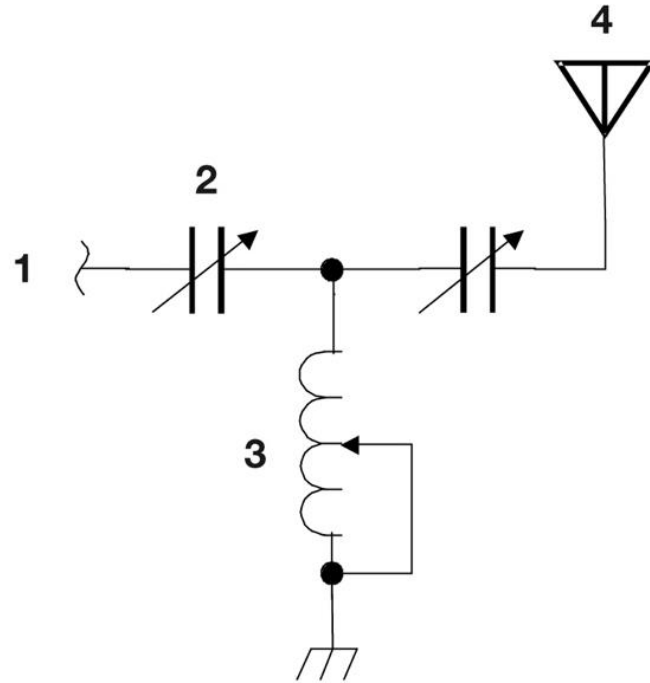

Figure T-3

What do the symbols on an electrical circuit schematic diagram represent?

- A. Electrical components
- B. Logic states
- C. Digital codes
- D. Traffic nodes

T6C12 HRLM (3-13)



What do the symbols on an electrical circuit schematic diagram represent?

- A. Electrical components**
- B. Logic states
- C. Digital codes
- D. Traffic nodes

T6C12 HRLM (3-13)

Which of the following is accurately represented in electrical circuit schematic diagrams?

- A. Wire lengths
- B. Physical appearance of components
- C. The way components are interconnected
- D. All of these choices are correct

T6C13 HRLM (3-14)



Which of the following is accurately represented in electrical circuit schematic diagrams?

- A. Wire lengths
- B. Physical appearance of components
- C. The way components are interconnected**
- D. All of these choices are correct

T6C13 HRLM (3-14)



Which of the following devices or circuits changes an alternating current into a varying direct current signal?

- A. Transformer
- B. Rectifier
- C. Amplifier
- D. Reflector

T6D01 HRLM (3-10)



Which of the following devices or circuits changes an alternating current into a varying direct current signal?

- A. Transformer
- B. Rectifier**
- C. Amplifier
- D. Reflector

T6D01 HRLM (3-10)



What best describes a relay?

- A. A switch controlled by an electromagnet
- B. A current controlled amplifier
- C. An optical sensor
- D. A pass transistor

T6D02 HRLM (3-12)

What best describes a relay?

- A. A switch controlled by an electromagnet**
- B. A current controlled amplifier
- C. An optical sensor
- D. A pass transistor

T6D02 HRLM (3-12)



What type of switch is represented by component 3 in figure T2?

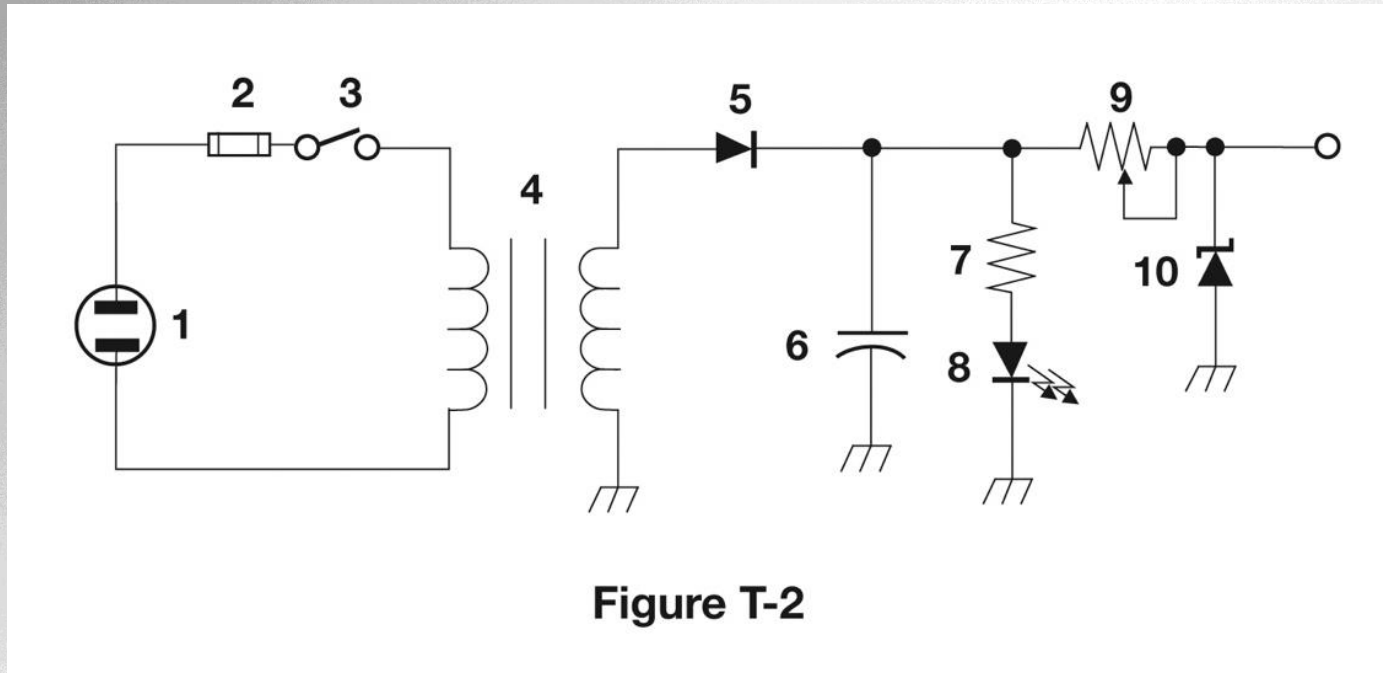

- A. Single-pole single-throw
- B. Single-pole double-throw
- C. Double-pole single-throw

- D. Double-pole double-throw

T6D03 HRLM (3-13)



ARRL The national association for
AMATEUR RADIO

What type of switch is represented by component 3 in figure T2?

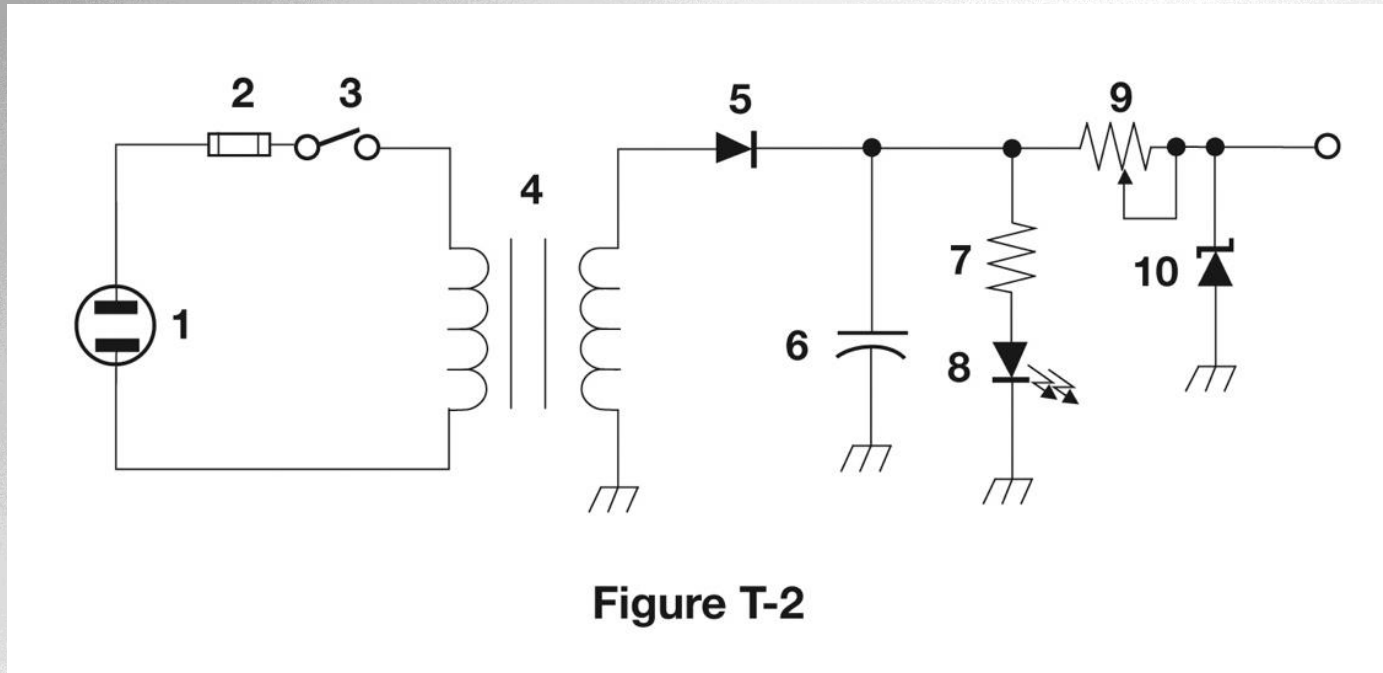

A. Single-pole single-throw

B. Single-pole double-throw

C. Double-pole single-throw

D. Double-pole double-throw

T6D03 HRLM (3-13)



ARRL The national association for
AMATEUR RADIO

Which of the following can be used to display signal strength on a numeric scale?

- A. Potentiometer
- B. Transistor
- C. Meter
- D. Relay

T6D04 HRLM (3-13)



Which of the following can be used to display signal strength on a numeric scale?

- A. Potentiometer
- B. Transistor
- C. Meter**
- D. Relay

T6D04 HRLM (3-13)



What component is commonly used to change 120V AC house current to a lower AC voltage for other uses?

- A. Variable capacitor
- B. Transformer
- C. Transistor
- D. Diode

T6D06 HRLM (3-9)



What component is commonly used to change 120V AC house current to a lower AC voltage for other uses?

- A. Variable capacitor
- B. Transformer**
- C. Transistor
- D. Diode

T6D06 HRLM (3-9)



Which of the following is commonly used as a visual indicator?

- A. LED
- B. FET
- C. Zener diode
- D. Bipolar transistor

T6D07 HRLM (3-11)



Which of the following is commonly used as a visual indicator?

- A. LED
- B. FET
- C. Zener diode
- D. Bipolar transistor

T6D07 HRLM (3-11)



Which of the following is used together with an inductor to make a tuned circuit?

- A. Resistor
- B. Zener diode
- C. Potentiometer
- D. Capacitor

T6D08 HRLM (3-9)



Which of the following is used together with an inductor to make a tuned circuit?

- A. Resistor
- B. Zener diode
- C. Potentiometer
- D. Capacitor**

T6D08 HRLM (3-9)



What is the name of a device that combines several semiconductors and other components into one package?

- A. Transducer
- B. Multi-pole relay
- C. Integrated circuit
- D. Transformer

T6D09 HRLM (3-11)



What is the name of a device that combines several semiconductors and other components into one package?

- A. Transducer
- B. Multi-pole relay
- C. Integrated circuit**
- D. Transformer

T6D09 HRLM (3-11)



What is the function of component 2 in Figure T1?

- A. Give off light when current flows through it
- B. Supply electrical energy
- C. Control the flow of current
- D. Convert electrical energy into radio waves

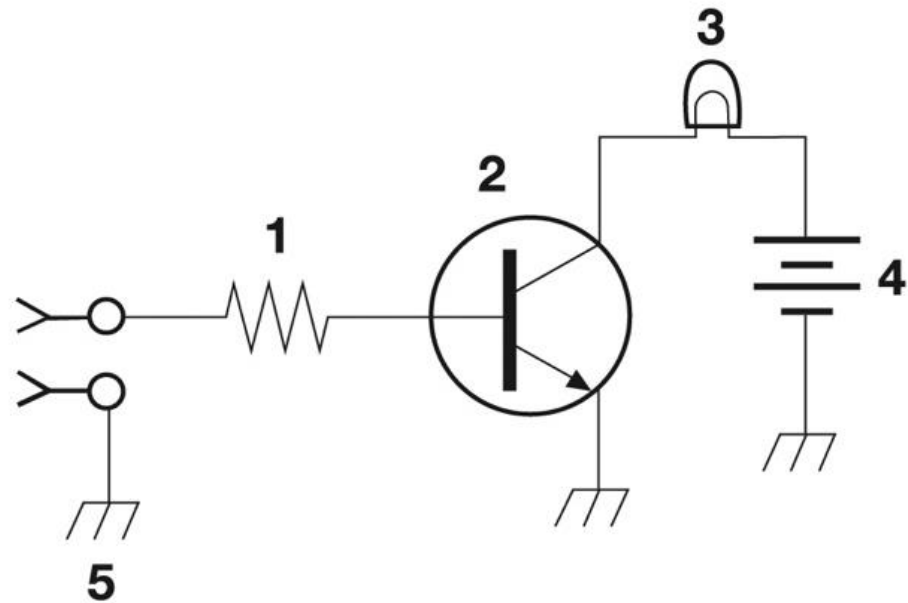

Figure T-1

T6D10 HRLM (3-11)

What is the function of component 2 in Figure T1?

- A. Give off light when current flows through it
- B. Supply electrical energy
- C. Control the flow of current**
- D. Convert electrical energy into radio waves

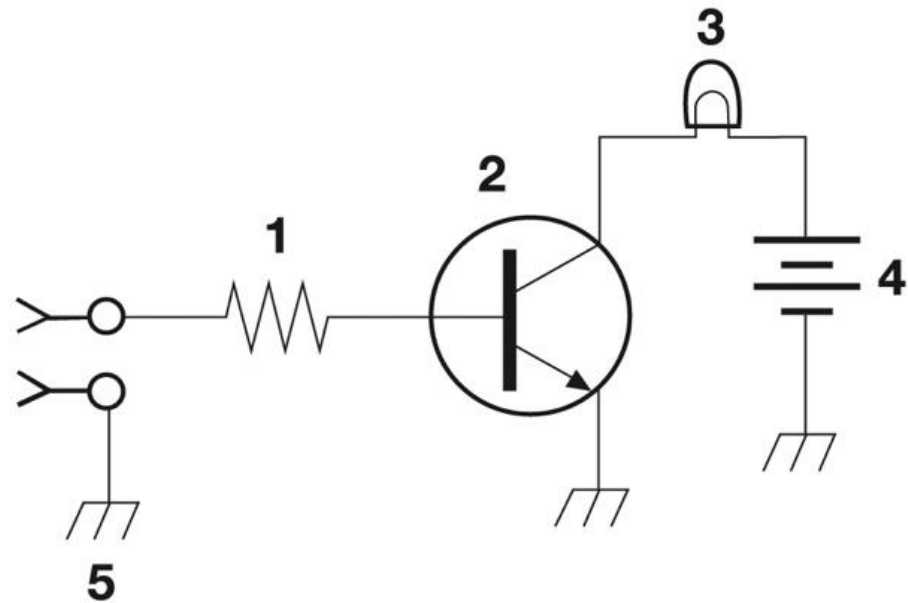

Figure T-1

T6D10 HRLM (3-11)

What is a simple resonant or tuned circuit?

- A. An inductor and a capacitor connected in series or parallel to form a filter
- B. A type of voltage regulator
- C. A resistor circuit used for reducing standing wave ratio
- D. A circuit designed to provide high fidelity audio

T6D11 HRLM (3-9)

What is a simple resonant or tuned circuit?

- A. An inductor and a capacitor connected in series or parallel to form a filter**
- B. A type of voltage regulator
- C. A resistor circuit used for reducing standing wave ratio
- D. A circuit designed to provide high fidelity audio

T6D11 HRLM (3-9)

What is the purpose of a fuse in an electrical circuit?

- A. To prevent power supply ripple from damaging a circuit
- B. To interrupt power in case of overload
- C. To limit current to prevent shocks
- D. All of these choices are correct

T0A04 HRLM (3-12)

What is the purpose of a fuse in an electrical circuit?

- A. To prevent power supply ripple from damaging a circuit
- B. To interrupt power in case of overload**
- C. To limit current to prevent shocks
- D. All of these choices are correct

T0A04 HRLM (3-12)

Why is it unwise to install a 20-ampere fuse in the place of a 5-ampere fuse?

- A. The larger fuse would be likely to blow because it is rated for higher current
- B. The power supply ripple would greatly increase
- C. Excessive current could cause a fire
- D. All of these choices are correct

T0A05 HRLM (3-12)

Why is it unwise to install a 20-ampere fuse in the place of a 5-ampere fuse?

- A. The larger fuse would be likely to blow because it is rated for higher current
- B. The power supply ripple would greatly increase
- C. Excessive current could cause a fire**
- D. All of these choices are correct

T0A05 HRLM (3-12)