

Technician License Course

Chapter 6

Lesson Plan Module 13 –
Contacting Other Hams – Part 1
Contact Basics, Band Plans, Making
Contacts and Using Repeaters



ARRL *The national association for
AMATEUR RADIO*

The Typical Telephone Conversation

- Greeting
- Identify who is participating
- Exchange information, generally taking turns
- Salutations
- End the conversation

The Typical Ham Contact (QSO)

- Greeting
- Identify who is participating
- Exchange information, generally taking turns
- Salutations
- End the conversation

Radio Manners

- Speak clearly and distinctly
 - Remember – you can't see the other person talking!
 - Use phonetics when needed
- Assume all communications are public – choose topics accordingly

Radio Manners

- Before transmitting, be sure the frequency is clear and you are authorized to use it!
- Station identification (10-minute rule)
- Frequencies are shared
 - No one has a prior claim to a frequency
 - Schedules, nets, pre-planned events
 - Be flexible, always have a “Plan B”



Radio Manners

- Signal reports
- Power level
 - Avoid excess power
- Location (QTH)
 - Grid locators
- RST
 - Readability (1–5)
 - Strength (1–9)
 - Tone (CW only 1–9)
 - “Your signal is 58”

Radio Manners

- Advice and assistance
 - Radio and antenna tests or checks
- Ham radio is self-regulated
 - ARRL Official Observers
- Logging contacts – on paper or computer
- QSLs and award programs



Band Plans

- A band plan is a formal plan for organizing types of operation on a band
 - Informal agreement – not a regulation
 - Intended for normal circumstances
 - Be flexible in times of heavy band use (contests, special events, DXpeditions)
 - Always have a “Plan B”

Making Contacts

- Repeater operation
 - Listen to see how the regulars operate
 - To announce your presence, just say your call
 - Respond to a call with the station's call followed by your own call
 - Often used by a club or group as a regional intercom

Making Contacts

- Repeater signal reports (examples)
 - Full-quieting: signal is strong enough that no noise is heard
 - Scratchy: occasional noise with your signal
 - Flutter: multi-path from a mobile station
 - In and out: occasionally copyable but mostly inaudible

Making Contacts

- HF on CW or SSB
 - “CQ” means “I am calling anyone”
 - To answer give the station’s call followed by your call once or twice
 - Use of phonetics is common

Making Contacts

- Taking turns
 - Nets
 - Roundtables
 - Shared contacts
- Breaking in
 - Wait for a pause
 - Give your call



ARRL *The national association for*
AMATEUR RADIO

Making Contacts

- Simplex FM
 - Each user takes turns to transmit
 - Works for stations close to each other
 - If you can hear the other station on the repeater input frequency, try simplex
 - 2 meters: 146.52 MHz
 - 70 cm: 446.00 MHz

Repeater Review

- Specialized transmitter/receiver interconnected by a controller.
- Generally located at a high place.
- Receives and simultaneously retransmits your signal on a different frequency.
- Dramatically extends line-of-sight range.

Repeater Review – How They Work

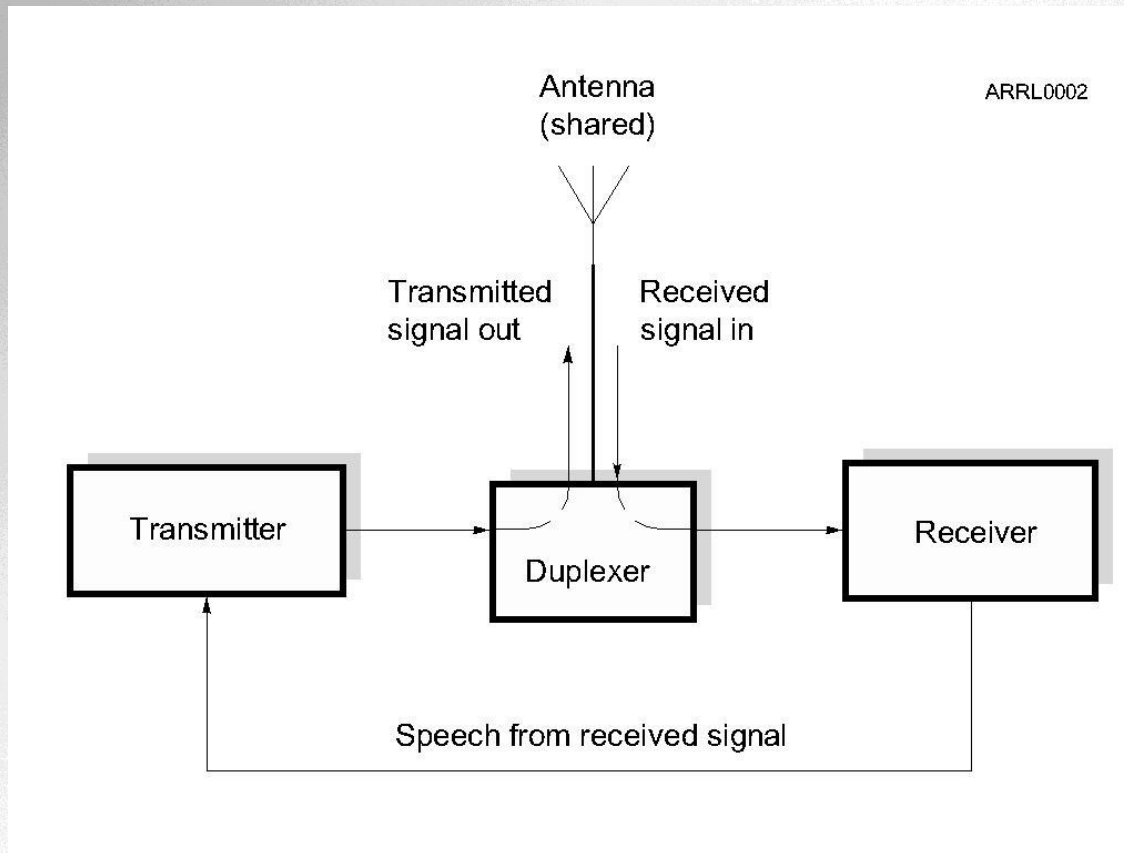

ARRL The national association for
AMATEUR RADIO

Duplex Communication

- Transmitting on one frequency while simultaneously listening on a different frequency.
- Repeaters use duplex communications.
- **Output frequency** – the frequency the repeater transmits on and you listen to.
- **Input frequency** – the frequency the repeater listens to and you transmit on.



ARRL The national association for
AMATEUR RADIO

Things to Know to Use a Repeater

- Output frequency
- Frequency offset
 - And therefore the input frequency
- Repeater access tones (if any)

Repeater Output Frequency

- Repeaters are frequently identified by their output frequency.
 - “Meet you on the 443.50 machine.”
 - Here the specific frequency is used.
 - “Let’s go to 94.”
 - Here an abbreviation for a standard repeater channel is used, meaning 146.94 MHz.
 - “How about the NARL repeater?”
 - Here the repeater is referenced by the sponsoring club name.



Repeater Frequency Offset

- The offset frequencies (shifts or splits) are standardized to help facilitate repeater use.
- There are + and – offsets depending on the plan.
- Different bands have different standardized amounts of offset.

Standard Repeater Offsets by Band

<i>Band</i>	<i>Offset</i>
10 Meters	–100 kHz
6 Meters	Varies by region: –500 kHz, –1 MHz, –1.7 MHz
2 Meters	+ or -600 kHz
1.25 Meters	–1.6 MHz
70 cm	+ or -5 MHz
902 MHz	12 MHz
1296 MHz	12 MHz



ARRL The national association for
AMATEUR RADIO

Repeater Access Tones

- Prevents accessing multiple repeaters at once.
- Subaudible low-frequency tone must be present before the repeater transmitter will turn on.
- Tones have various names (depending on equipment manufacturer).
 - CTCSS (continuous tone coded squelch system)
 - PL (a Motorola trade name for CTCSS)
 - Privacy codes or tones
 - DCS (digital coded squelch)

Repeater Access Tones

- Access tones are usually published along with repeater frequencies.
- Could also be announced when the repeater identifies.
 - “PL is 123.0” meaning 123.0 Hz
- Tones are generally programmed into the radio along with frequency and offset.

Repeater Control

- Repeater identification (Morse code or synthesized voice)
 - Same ID requirements as you have
- Time-out protection
 - Protects against continuous transmission in the event of a stuck PTT or long-winded speaker
 - Usually three minutes
- Courtesy beep or tone signals time-out timer reset
- May have an autopatch system for phone calls



ARRL The national association for
AMATEUR RADIO

Common Problems

- Off frequency: causes audio distortion
- Low batteries: weak signal, audio distortion
- Poor location: hear repeater OK, can't make or maintain contact
- Access tone off or wrong: repeater is strong but can't access it
- Repeater drops in and out of your receiver: squelch setting too high

Digital Repeater Systems

- Repeaters linked by the Internet
- Use digital audio – Voice Over Internet Protocol (VOIP)
 - Similar to Skype
- Allows communication world-wide
- Internet Linking Relay Project (IRLP)
- Echolink
- Access codes on system websites



D-STAR

- Both a repeater linking system and a digital voice protocol
- DV: Digital Voice mode (voice + 1200 baud data)
- DD: Digital Data mode (128 kbps data)
- Repeaters linked together worldwide
- Call user-to-user based on call sign
- Currently an ICOM system
- Yaesu and Kenwood also building digital systems



Practice Questions



What is the most common repeater frequency offset in the 2 meter band?

- A. Plus 500 kHz
- B. Plus or minus 600 kHz
- C. Minus 500 kHz
- D. Only plus 600 kHz

T2A01 HRLM (6-16)

What is the most common repeater frequency offset in the 2 meter band?

- A. Plus 500 kHz
- B. Plus or minus 600 kHz**
- C. Minus 500 kHz
- D. Only plus 600 kHz

T2A01 HRLM (6-16)



What is the national calling frequency for FM simplex operations in the 70 cm band?

- A. 146.520 MHz
- B. 145.000 MHz
- C. 432.100 MHz
- D. 446.000 MHz

T2A02 HRLM (6-14)



What is the national calling frequency for FM simplex operations in the 70 cm band?

- A. 146.520 MHz
- B. 145.000 MHz
- C. 432.100 MHz
- D. 446.000 MHz**

T2A02 HRLM (6-14)



What is a common repeater frequency offset in the 70 cm band?

- A. Plus or minus 5 MHz
- B. Plus or minus 600 kHz
- C. Minus 600 kHz
- D. Plus 600 kHz

T2A03 HRLM (6-16)



What is a common repeater frequency offset in the 70 cm band?

- A. Plus or minus 5 MHz
- B. Plus or minus 600 kHz
- C. Minus 600 kHz
- D. Plus 600 kHz

T2A03 HRLM (6-16)



What is an appropriate way to call another station on a repeater if you know the other station's call sign?

- A. Say "break, break" then say the station's call sign
- B. Say the station's call sign then identify with your call sign
- C. Say "CQ" three times then the other station's call sign
- D. Wait for the station to call "CQ" then answer it

T2A04 HRLM (6-12)



What is an appropriate way to call another station on a repeater if you know the other station's call sign?

- A. Say "break, break" then say the station's call sign
- B. Say the station's call sign then identify with your call sign**
- C. Say "CQ" three times then the other station's call sign
- D. Wait for the station to call "CQ" then answer it

T2A04 HRLM (6-12)



How should you respond to a station calling CQ?

- A. Transmit CQ followed by the other station's call sign
- B. Transmit our call sign followed by the other station's call sign
- C. Transmit the other station's call sign followed by your call sign
- D. Transmit a signal report followed by your call sign

T2A05 HRLM (6-13)

How should you respond to a station calling CQ?

- A. Transmit CQ followed by the other station's call sign
- B. Transmit our call sign followed by the other station's call sign
- C. Transmit the other station's call sign followed by your call sign**
- D. Transmit a signal report followed by your call sign

T2A05 HRLM (6-13)

What is the meaning of the procedural signal "CQ"?

- A. Call on the quarter hour
- B. A new antenna is being tested (no station should answer)
- C. Only the called station should transmit
- D. Calling any station

T2A08 HRLM (6-13)

What is the meaning of the procedural signal "CQ"?

- A. Call on the quarter hour
- B. A new antenna is being tested (no station should answer)
- C. Only the called station should transmit
- D. Calling any station**

T2A08 HRLM (6-13)

What brief statement is often used in place of "CQ" to indicate that you are listening on a repeater?

- A. The words "Hello test" followed by your call sign
- B. Your call sign
- C. The repeater call sign followed by your call sign
- D. The letters "QSY" followed by your call sign

T2A09 HRLM (6-9)



What brief statement is often used in place of "CQ" to indicate that you are listening on a repeater?

- A. The words "Hello test" followed by your call sign
- B. Your call sign**
- C. The repeater call sign followed by your call sign
- D. The letters "QSY" followed by your call sign

T2A09 HRLM (6-9)



Which of the following is a guideline to use when choosing an operating frequency for calling CQ?

- A. Listen first to be sure that no one else is using the frequency
- B. Ask if the frequency is in use
- C. Make sure you are in your assigned band
- D. All of these choices are correct

T2A12 HRLM (6-13)



Which of the following is a guideline to use when choosing an operating frequency for calling CQ?

- A. Listen first to be sure that no one else is using the frequency
- B. Ask if the frequency is in use
- C. Make sure you are in your assigned band
- D. All of these choices are correct**

T2A12 HRLM (6-13)



What is the term used to describe an amateur station that is transmitting and receiving on the same frequency?

- A. Full duplex communication
- B. Diplex communication
- C. Simplex communication
- D. Multiplex

T2B01 HRLM (6-9)



What is the term used to describe an amateur station that is transmitting and receiving on the same frequency?

- A. Full duplex communication
- B. Diplex communication
- C. Simplex communication**
- D. Multiplex

T2B01 HRLM (6-9)



What is the term used to describe the use of a sub-audible tone transmitted with normal voice audio to open the squelch of a receiver?

- A. Carrier squelch
- B. Tone burst
- C. DTMF
- D. CTCSS

T2B02 HRLM (6-16)



What is the term used to describe the use of a sub-audible tone transmitted with normal voice audio to open the squelch of a receiver?

- A. Carrier squelch
- B. Tone burst
- C. DTMF
- D. CTCSS**

T2B02 HRLM (6-16)



Which of the following common problems might cause you to be able to hear but not access a repeater even when transmitting with the proper offset?

- A. The repeater receiver may require an audio tone burst for access
- B. The repeater receiver may require a CTCSS tone for access
- C. The repeater receiver may require a DCS tone sequence for access
- D. All of these choices are correct

T2B04 HRLM (6-17)



Which of the following common problems might cause you to be able to hear but not access a repeater even when transmitting with the proper offset?

- A. The repeater receiver may require an audio tone burst for access
- B. The repeater receiver may require a CTCSS tone for access
- C. The repeater receiver may require a DCS tone sequence for access
- D. All of these choices are correct**

T2B04 HRLM (6-17)



Which "Q" signal indicates that you are receiving interference from other stations?

- A. QRM
- B. QRN
- C. QTH
- D. QSB

T2B10 HRLM (6-5)



Which "Q" signal indicates that you are receiving interference from other stations?

- A. QRM
- B. QRN
- C. QTH
- D. QSB

T2B10 HRLM (6-5)



Which "Q" signal indicates that you are changing frequency?

- A. QRU
- B. QSY
- C. QSL
- D. QRZ

T2B11 HRLM (6-5)



Which "Q" signal indicates that you are changing frequency?

- A. QRU
- B. QSY**
- C. QSL
- D. QRZ

T2B11 HRLM (6-5)



Under what circumstances should you consider communicating via simplex rather than a repeater?

- A. When the stations can communicate directly without using a repeater
- B. Only when you have an endorsement for simplex operation on your license
- C. Only when third party traffic is not being passed
- D. Only if you have simplex modulation capability

T2B12 HRLM (6-14)

Under what circumstances should you consider communicating via simplex rather than a repeater?

- A. When the stations can communicate directly without using a repeater**
- B. Only when you have an endorsement for simplex operation on your license
- C. Only when third party traffic is not being passed
- D. Only if you have simplex modulation capability

T2B12 HRLM (6-14)



What should be done to insure that voice message traffic containing proper names and unusual words are copied correctly by the receiving station?

- A. The entire message should be repeated at least four times
- B. Such messages must be limited to no more than 10 words
- C. Such words and terms should be spelled out using a standard phonetic alphabet
- D. All of these choices are correct

T2C03 HRLM (6-22)



What should be done to insure that voice message traffic containing proper names and unusual words are copied correctly by the receiving station?

- A. The entire message should be repeated at least four times
- B. Such messages must be limited to no more than 10 words
- C. Such words and terms should be spelled out using a standard phonetic alphabet**
- D. All of these choices are correct

T2C03 HRLM (6-22)



Which of the following describes the common meaning of the term “repeater offset”?

- A. The distance between the repeater’s transmit and receive antennas
- B. The time delay before the repeater timer resets
- C. The difference between the repeater’s transmit and receive frequencies
- D. Matching the antenna impedance to the feed line impedance

T4B11 HRLM (6-16)



Which of the following describes the common meaning of the term “repeater offset”?

- A. The distance between the repeater’s transmit and receive antennas
- B. The time delay before the repeater timer resets
- C. The difference between the repeater’s transmit and receive frequencies**
- D. Matching the antenna impedance to the feed line impedance

T4B11 HRLM (6-16)



What might be the problem if you receive a report that your audio signal through the repeater is distorted or unintelligible?

- A. Your transmitter may be slightly off frequency
- B. Your batteries may be running low
- C. You could be in a bad location
- D. All of these choices are correct

T7B10 HRLM (6-12)



What might be the problem if you receive a report that your audio signal through the repeater is distorted or unintelligible?

- A. Your transmitter may be slightly off frequency
- B. Your batteries may be running low
- C. You could be in a bad location
- D. All of these choices are correct**

T7B10 HRLM (6-12)



What is a grid locator?

- A. A letter-number designator assigned to a geographic location
- B. A letter-number designator assigned to an azimuth and elevation
- C. An instrument for neutralizing a final amplifier
- D. An instrument for radio direction finding

T8C05 HRLM (6-4)



What is a grid locator?

- A. A letter-number designator assigned to a geographic location**
- B. A letter-number designator assigned to an azimuth and elevation
- C. An instrument for neutralizing a final amplifier
- D. An instrument for radio direction finding

T8C05 HRLM (6-4)

How is access to an IRLP node accomplished?

- A. By obtaining a password which is sent via voice to the node
- B. By using DTMF signals
- C. By entering the proper Internet password
- D. By using CTCSS tone codes

T8C06 HRLM (6-19)

How is access to an IRLP node accomplished?

- A. By obtaining a password which is sent via voice to the node
- B. By using DTMF signals**
- C. By entering the proper Internet password
- D. By using CTCSS tone codes

T8C06 HRLM (6-19)

How might you obtain a list of active nodes that use VoIP?

- A. From the FCC Rulebook
- B. From your local emergency coordinator
- C. From a repeater directory
- D. From the local repeater frequency coordinator

T8C09 HRLM (6-19)

How might you obtain a list of active nodes that use VoIP?

- A. From the FCC Rulebook
- B. From your local emergency coordinator
- C. From a repeater directory**
- D. From the local repeater frequency coordinator

T8C09 HRLM (6-19)

How do you select a specific IRLP node when using a portable transceiver?

- A. Choose a specific CTCSS tone
- B. Choose the correct DSC tone
- C. Access the repeater autopatch
- D. Use the keypad to transmit the IRLP node ID

T8C10 HRLM (6-19)

How do you select a specific IRLP node when using a portable transceiver?

- A. Choose a specific CTCSS tone
- B. Choose the correct DSC tone
- C. Access the repeater autopatch
- D. Use the keypad to transmit the IRLP node ID**

T8C10 HRLM (6-19)

What is meant by Voice Over Internet Protocol (VoIP) as used in amateur radio?

- A. A set of rules specifying how to identify your station when linked over the Internet to another station
- B. A set of guidelines for working DX during contests using Internet access
- C. A technique for measuring the modulation quality of a transmitter using remote sites monitored via the Internet
- D. A method of delivering voice communications over the Internet using digital techniques

T8C12 HRLM (6-19)



What is meant by Voice Over Internet Protocol (VoIP) as used in amateur radio?

- A. A set of rules specifying how to identify your station when linked over the Internet to another station
- B. A set of guidelines for working DX during contests using Internet access
- C. A technique for measuring the modulation quality of a transmitter using remote sites monitored via the Internet
- D. A method of delivering voice communications over the Internet using digital techniques**

T8C12 HRLM (6-19)



What is the Internet Radio Linking Project (IRLP)?

- A. A technique to connect amateur radio systems, such as repeaters, via the Internet using a Voice Over Internet Protocol
- B. A system for providing access to websites via amateur radio
- C. A system for informing amateurs real time of the frequency of active DX stations
- D. A technique for measuring signal strength of an amateur transmitter via the Internet

T8C13 HRLM (6-18)



What is the Internet Radio Linking Project (IRLP)?

- A. A technique to connect amateur radio systems, such as repeaters, via the Internet using a Voice Over Internet Protocol**
- B. A system for providing access to websites via amateur radio
- C. A system for informing amateurs real time of the frequency of active DX stations
- D. A technique for measuring signal strength of an amateur transmitter via the Internet

T8C13 HRLM (6-18)

