

FEATURES

- HIGH FREQUENCY OPERATION TO 3 GHz
- SELECTABLE DIVIDE RATIO: ÷64, ÷128, ÷256
- LOW CURRENT CONSUMPTION: 19 mA at 5 V
- SMALL PACKAGE: 8 pin SSOP
- AVAILABLE IN TAPE AND REEL

DESCRIPTION

The UPB1506GV and UPB1507GV are Silicon MMIC digital prescalers manufactured with the NESAT™ IV silicon bipolar process. They feature high frequency response to 3 GHz, selectable divide-by-64, 128, or 256 modes, and operate on a 5 volt supply while drawing only 19 mA. The devices are housed in a small 8 pin SSOP package that contributes to system miniaturization. These devices are designed for use in a PLL synthesizer for DBS and CATV settop and WLAN applications.

TEST CIRCUIT

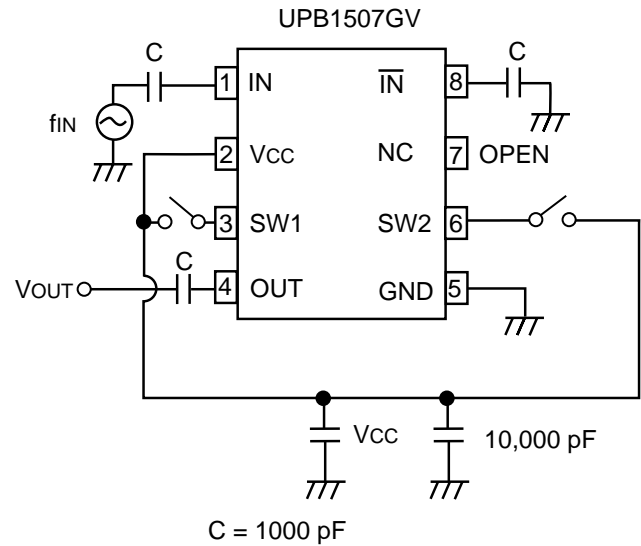

ELECTRICAL CHARACTERISTICS (TA = -40 to +85°C, Vcc = 4.5 to 5.5 V, Zs = 50Ω)

PART NUMBER PACKAGE OUTLINE			UPB1506GV,UPB1507GV S08		
SYMBOLS	PARAMETERS AND CONDITIONS	UNITS	MIN	TYP	MAX
Icc	Circuit Current	mA	12.5	19	26.5
f _{IN(U)}	Upper Limit Operating Frequency, P _{IN} = -15 to +6 dBm	GHz		3.0	
f _{IN(L)1}	Lower Limit Operating Frequency, P _{IN} = -10 to +6 dBm	GHz			0.5
f _{IN(L)2}	Lower Limit Operating Frequency, P _{IN} = -15 to +6 dBm	GHz			1.0
P _{IN1}	Input Power, f _{IN} = 1.0 to 3.0 GHz	dBm	-15		+6
P _{IN2}	Input Power, f _{IN} = 0.5 to 1.0 GHz	dBm	-10		+6
V _{OUT}	Output Voltage, C _L = 0.8 pF	V _{P-P}	1.2	1.6	
V _{IN(H)}	Division Ratio Control Input High	V		V _{cc}	
V _{IN(L)}	Division Ratio Control Input Low	V		OPEN or GND	

ABSOLUTE MAXIMUM RATINGS¹ (T_A = 25°C)

SYMBOLS	PARAMETERS	UNITS	RATINGS
V _{CC}	Supply Voltage	V	-0.5 to 6.0
V _{IN}	Input Voltage	V	-0.5 to V _{CC} + 0.5
P _{IN}	Input Power	dBm	+10
P _D	Power Dissipation ²	mW	250
T _{OP}	Operating Temperature	°C	-45 to +85
T _{STG}	Storage Temperature	°C	-55 to +150

Notes:

1. Operation in excess of any one of these parameters may result in permanent damage.
2. Mounted on a double-sided copper clad 50x50x1.6 mm epoxy glass PWB (T_A = +85°C).

RECOMMENDED OPERATING CONDITIONS

SYMBOL	PARAMETER	UNITS	MIN	TYP	MAX
V _{CC}	Supply Voltage	V	4.5	5.0	5.5
T _{OP}	Operating Temperature	°C	-40	+25	+85

PIN DESCRIPTIONS

Pin No.		Pin Name	Applied Voltage (V)	Pin Voltage (V)	Description															
UPB1506GV	UPB1507GV																			
2	1	IN	–	2.9	Signal input pin. This pin should be coupled to the source with a capacitor (eg 1000 pF).															
3	8	$\overline{\text{IN}}$	–	2.9	Signal input bypass pin. This pin must be equipped with a bypass capacitor (eg 1000 pF) to ground.															
4	5	GND	0	–	Ground pin. Ground pattern on the board should be formed as wide as possible to minimize ground impedance.															
1	3	SW1	H/L	–	Divided ratio input pin. The ratio can be controlled by the following input data to these pins. <table border="1" style="margin: 10px auto;"> <thead> <tr> <th colspan="2"></th> <th colspan="2">SW2</th> </tr> <tr> <th colspan="2"></th> <th>H</th> <th>L</th> </tr> </thead> <tbody> <tr> <th rowspan="2">SW1</th> <th>H</th> <td>+64</td> <td>÷128</td> </tr> <tr> <th>L</th> <td>÷128</td> <td>÷256</td> </tr> </tbody> </table>			SW2				H	L	SW1	H	+64	÷128	L	÷128	÷256
		SW2																		
		H	L																	
SW1	H	+64	÷128																	
	L	÷128	÷256																	
6	6	SW2			These pins should be equipped with a bypass capacitor (e.g. 1000 pF) to ground.															
8	2	V _{CC}	4.5 to 5.5	–	Power supply pin. This pin must be equipped with bypass capacitor (eg 1000 pF) to ground.															
7	4	OUT	–	2.6 to 4.7	Divided frequency output pin. This pin is designed as an emitter follower output. This pin can be connected to CMOS input due to 1.2 V _{p-p} MIN output.															
5	7	NC	–	–	No connection. This pin must be opened.															

TYPICAL PERFORMANCE CURVES ($T_A = +25^\circ\text{C}$ unless otherwise noted)

CURRENT vs. VOLTAGE and TEMPERATURE

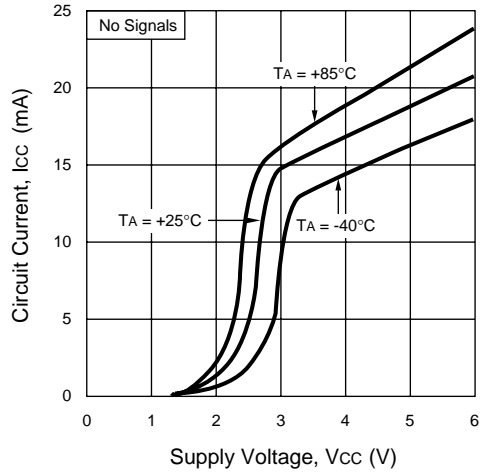

INPUT POWER vs. INPUT FREQUENCY and VOLTAGE

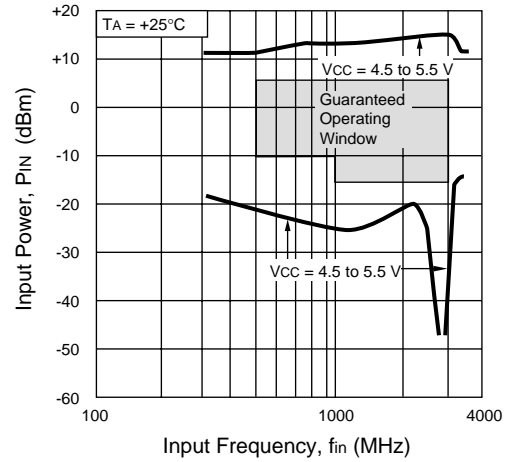

INPUT POWER vs. INPUT FREQUENCY and TEMPERATURE

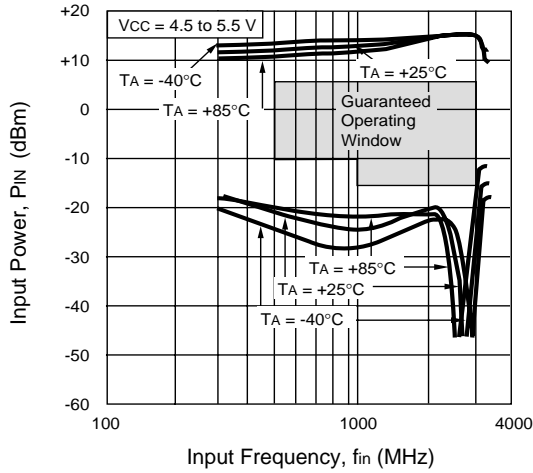

OUTPUT VOLTAGE vs. INPUT FREQUENCY and VOLTAGE

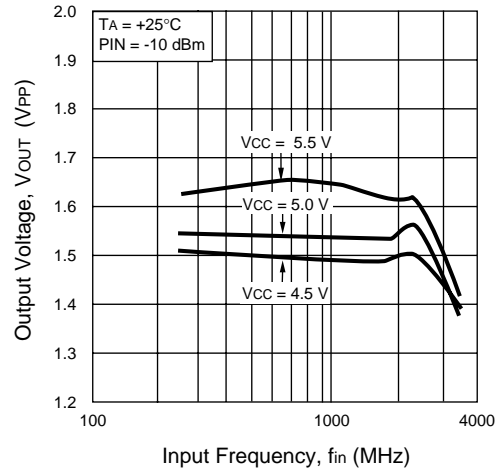

OUTPUT VOLTAGE vs. INPUT FREQUENCY and VOLTAGE

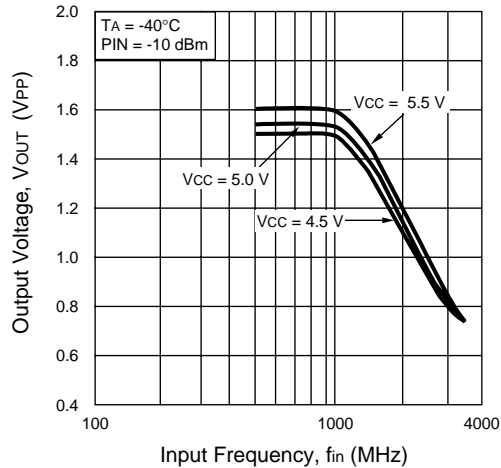

OUTPUT VOLTAGE vs. INPUT FREQUENCY and VOLTAGE

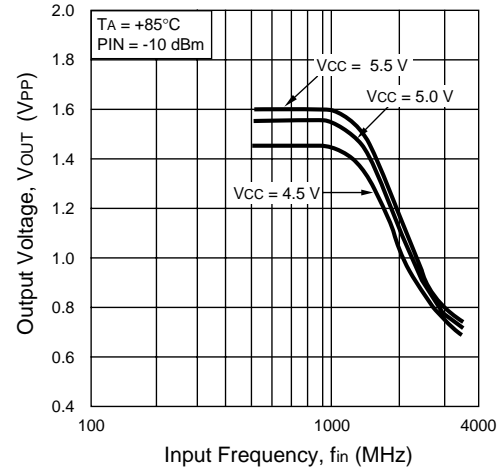

TYPICAL PERFORMANCE CURVES (TA = +25°C unless otherwise noted)

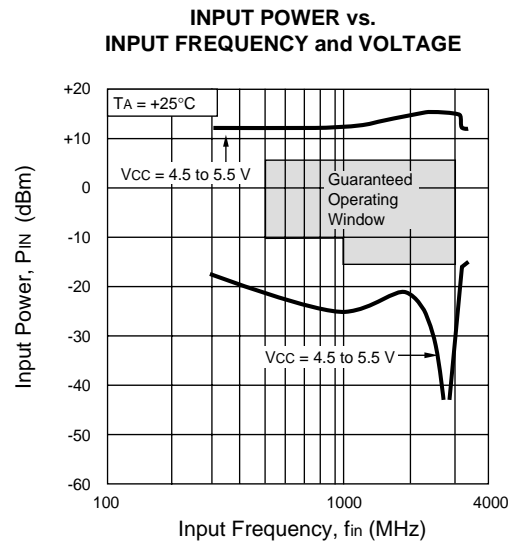
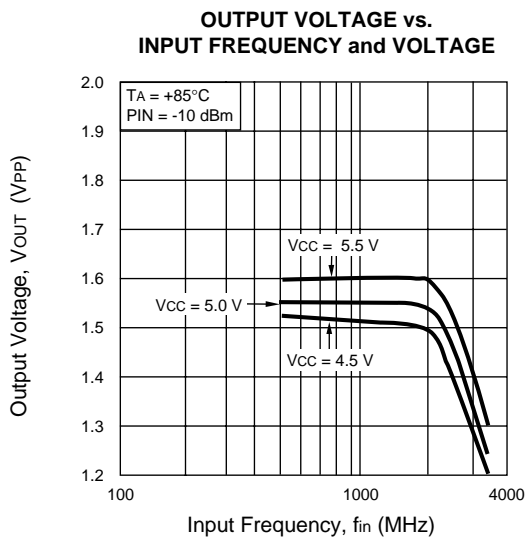
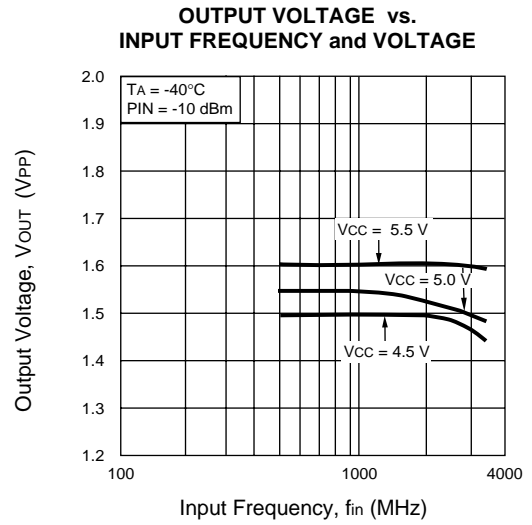
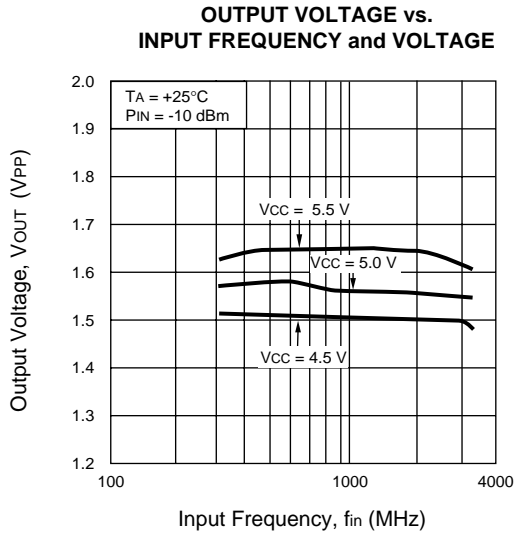
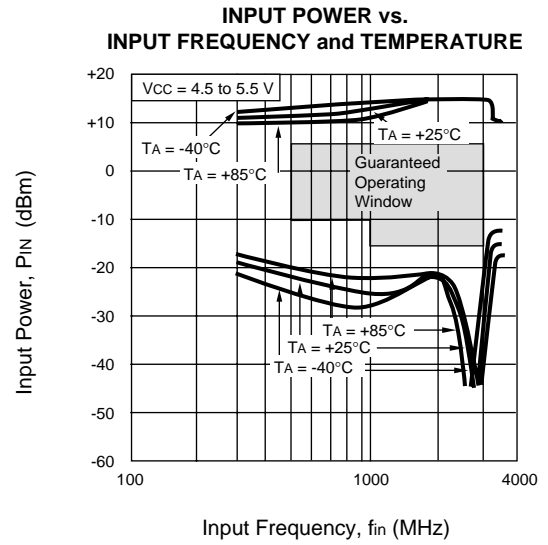
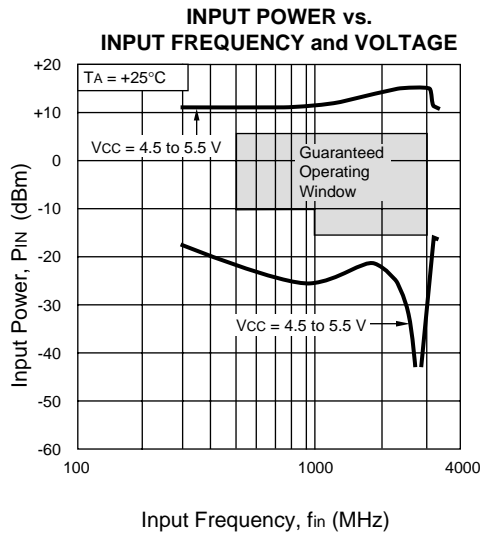

TYPICAL PERFORMANCE CURVES (TA = +25°C unless otherwise noted)

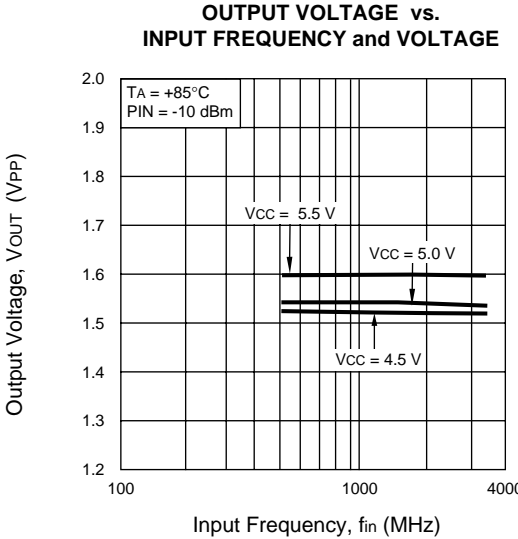
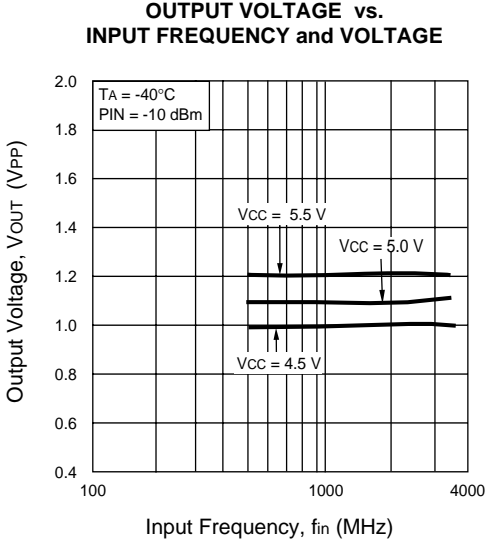
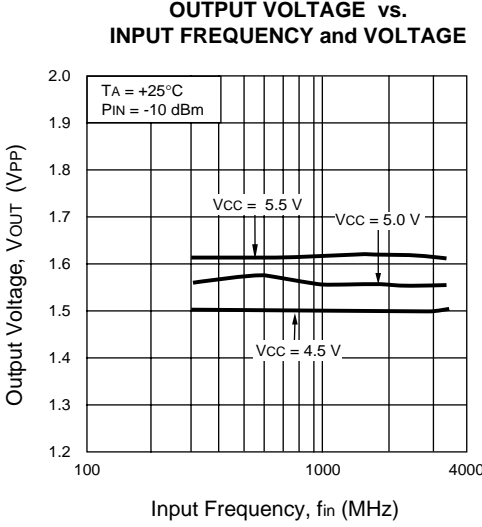
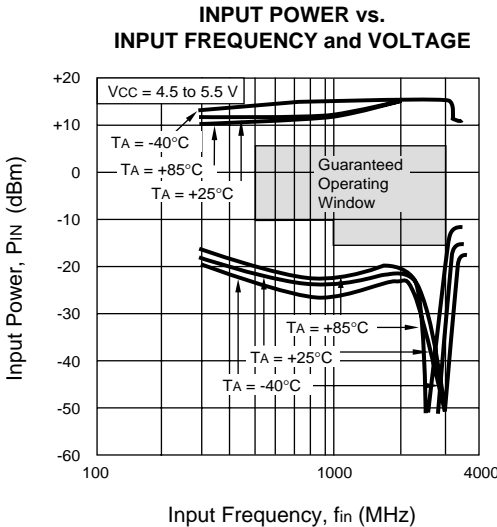

TYPICAL SCATTERING PARAMETERS (T_A = 25°C)

UPB1506GV

S₁₁ vs. INPUT FREQUENCY
V_{cc} = 5.0 V

S₁₁ Z
REF 1.0 Units
3 200.0 mUnits/
▽ 33.881 Ω -52.875 Ω
hp

C

D

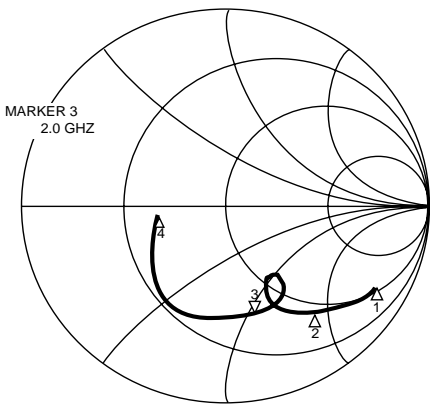

START 0.500000000 GHz
STOP 3.000000000 GHz

FREQUENCY	S ₁₁	
	MAG	ANG
0.5	0.868	-26.6
0.6	0.828	-32.6
0.7	0.794	-37.4
0.8	0.761	-41.9
0.9	0.721	-46.5
1.0	0.706	-49.3
1.1	0.662	-54.0
1.2	0.629	-57.2
1.3	0.595	60.2
1.4	0.554	-62.9
1.5	0.516	-64.8
1.6	0.440	-61.9
1.7	0.428	51.0
1.8	0.543	-61.5
1.9	0.555	-68.4
2.0	0.560	-74.7
2.1	0.558	-79.5
2.2	0.564	-84.9
2.3	0.570	-90.9
2.4	0.574	-98.3
2.5	0.574	-107.9
2.6	0.564	-118.3
2.7	0.530	-131.4
2.8	0.476	-144.6
2.9	0.411	-159.1
3.0	0.331	-175.8

UPB1506GV

S₂₂ vs. OUTPUT FREQUENCY
Divide by 64 mode, V_{cc} = 5.0 V

S₂₂ Z
REF 1.0 Units
1 200.0 mUnits/
▽ 171.22 Ω -04.438 Ω
hp

C

D

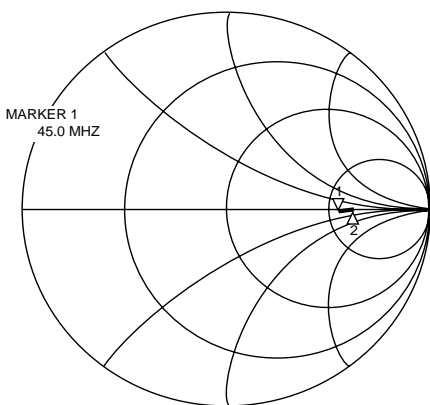

START 0.045000000 GHz
STOP 0.100000000 GHz

FREQUENCY	S ₂₂	
	MAG	ANG
45.0	0.542	-1.4
50.0	0.602	-0.3
55.0	0.616	0.0
60.0	0.605	1.1
65.0	0.609	0.7
70.0	0.616	0.3
75.0	0.620	0.1
80.0	0.622	0.0
85.0	0.619	0.6
90.0	0.610	0.9
95.0	0.626	-0.7
100.0	0.623	-1.7

TYPICAL SCATTERING PARAMETERS ($T_A = 25^\circ\text{C}$)

UPB1506GV

S22 vs. OUTPUT FREQUENCY
Divide by 128 mode, Vcc = 5.0 V

S22 Z
REF 1.0 Units
1 200.0 mUnits/
▽ 192.34 Ω 03.109 Ω

hp

C

D

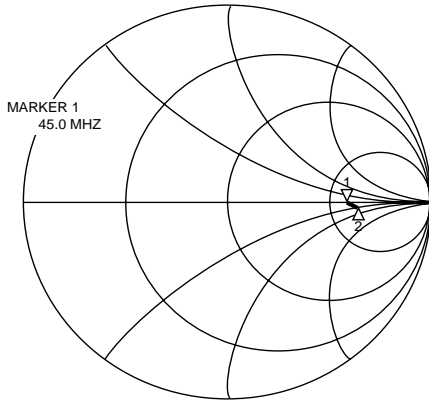

START 0.045000000 GHz
STOP 0.100000000 GHz

Δ₁ : 45 MHz
Δ₂ : 100 MHz

FREQUENCY	S22	
	MHz	MAG
45.0	0.590	-0.4
50.0	0.604	-1.0
55.0	0.610	-1.1
60.0	0.607	-0.8
65.0	0.548	-5.9
70.0	0.630	-0.0
75.0	0.615	-1.0
80.0	0.618	-1.4
85.0	0.617	-1.2
90.0	0.616	-2.2
95.0	0.623	-2.4
100.0	0.624	-2.3

UPB1506GV

S22 vs. OUTPUT FREQUENCY
Divide by 256 mode, Vcc = 5.0 V

S22 Z
REF 1.0 Units
1 200.0 mUnits/
▽ 199.25 Ω -05.992 Ω

hp

C

D

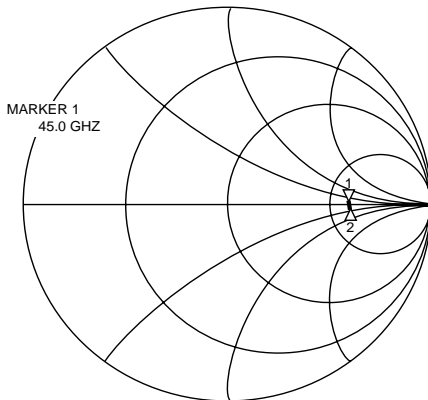

START 0.045000000 GHz
STOP 0.100000000 GHz

Δ₁ : 45 MHz
Δ₂ : 100 MHz

FREQUENCY	S22	
	MHz	MAG
45.0	0.601	-0.9
50.0	0.609	-1.6
55.0	0.611	-1.5
60.0	0.620	-1.4
65.0	0.607	-2.1
70.0	0.615	-1.9
75.0	0.613	-3.2
80.0	0.611	-2.8
85.0	0.607	-2.5
90.0	0.605	-2.4
95.0	0.610	-3.0
100.0	0.608	-2.8

UPB1506GV, UPB1507GV

TYPICAL SCATTERING PARAMETERS (T_A = 25°C)

UPB1507GV

S₁₁ vs. INPUT FREQUENCY
V_{CC} = 5.0 V

S₁₁ Z
REF 1.0 Units
4 200.0 mUnits/
▽ 38.111 Ω 0.9707 Ω

hp

C

D

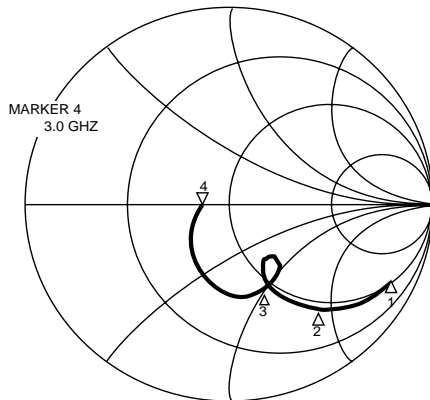

START 0.500000000 GHz
STOP 3.000000000 GHz

FREQUENCY	S ₁₁	
	MAG	ANG
0.5	0.857	-27.5
0.6	0.849	-32.0
0.7	0.800	-38.9
0.8	0.764	-43.8
0.9	0.725	-49.0
1.0	0.665	-50.9
1.1	0.619	-55.3
1.2	0.573	-59.3
1.3	0.531	-61.3
1.4	0.484	-62.8
1.5	0.439	-63.0
1.6	0.377	-59.1
1.7	0.340	-54.1
1.8	0.377	-54.7
1.9	0.441	-59.5
2.0	0.464	-67.2
2.1	0.443	-67.4
2.2	0.466	-74.5
2.3	0.465	-81.3
2.4	0.454	-89.4
2.5	0.433	-99.2
2.6	0.383	-109.6
2.7	0.350	-114.0
2.8	0.332	-124.2
2.9	0.271	-141.2
3.0	0.185	-163.6

UPB1507GV

S₂₂ vs. OUTPUT FREQUENCY
Divide by 64 mode, V_{CC} = 5.0 V

S₂₂ Z
REF 1.0 Units
1 200.0 mUnits/
▽ 185.13 Ω 17.789 Ω

hp

C

D

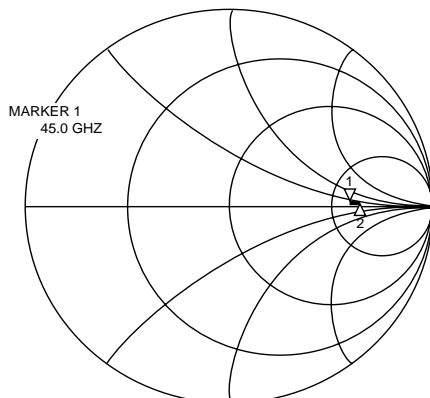

START 0.045000000 GHz
STOP 0.100000000 GHz

FREQUENCY	S ₂₂	
	MAG	ANG
45.0	0.580	3.4
50.0	0.572	2.5
55.0	0.574	3.0
60.0	0.574	2.7
65.0	0.584	3.0
70.0	0.587	2.6
75.0	0.592	2.4
80.0	0.587	2.6
85.0	0.589	2.9
90.0	0.591	2.9
95.0	0.573	1.7
100.0	0.604	2.9

TYPICAL SCATTERING PARAMETERS ($T_A = 25^\circ\text{C}$)

UPB1507GV

S22 vs. OUTPUT FREQUENCY
Divide by 128 mode, $V_{CC} = 5.0\text{ V}$

S22 Z
REF 1.0 Units
1 200.0 mUnits/
▽ 185.02 Ω 18.953 Ω

hp

C

D

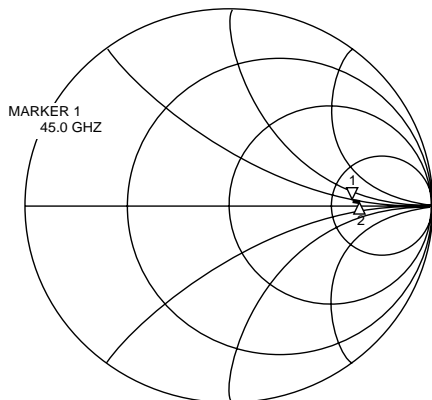

START 0.045000000 GHz
STOP 0.100000000 GHz

FREQUENCY **S22**

MHz **MAG** **ANG**

45.0	0.578	3.2
50.0	0.571	2.8
55.0	0.572	3.3
60.0	0.576	3.0
65.0	0.584	3.1
70.0	0.587	2.8
75.0	0.589	2.4
80.0	0.589	2.8
85.0	0.588	3.0
90.0	0.593	2.8
95.0	0.598	3.0
100.0	0.602	2.9

Δ₁ : 45 MHz

Δ₂ : 100 MHz

UPB1507GV

S22 vs. OUTPUT FREQUENCY
Divide by 256 mode, $V_{CC} = 5.0\text{ V}$

S22 Z
REF 1.0 Units
4 200.0 mUnits/
▽ 186.76 Ω 17.82 Ω

hp

C

D

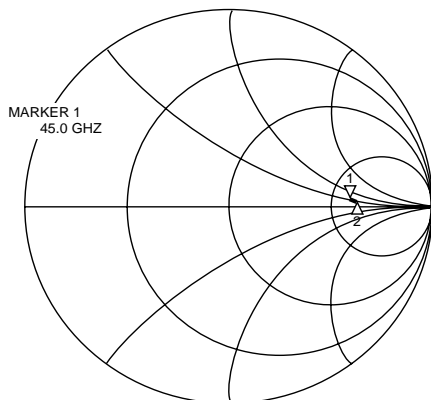

START 0.045000000 GHz
STOP 0.100000000 GHz

FREQUENCY **S22**

MHz **MAG** **ANG**

45.0	0.580	3.0
50.0	0.572	2.8
55.0	0.571	2.9
60.0	0.576	2.9
65.0	0.585	3.2
70.0	0.590	2.8
75.0	0.589	2.5
80.0	0.590	2.6
85.0	0.588	2.9
90.0	0.597	2.9
95.0	0.600	3.1
100.0	0.601	3.1

Δ₁ : 45 MHz

Δ₂ : 100 MHz

SYSTEM APPLICATION EXAMPLE

RF unit block of Analog DBS tuners

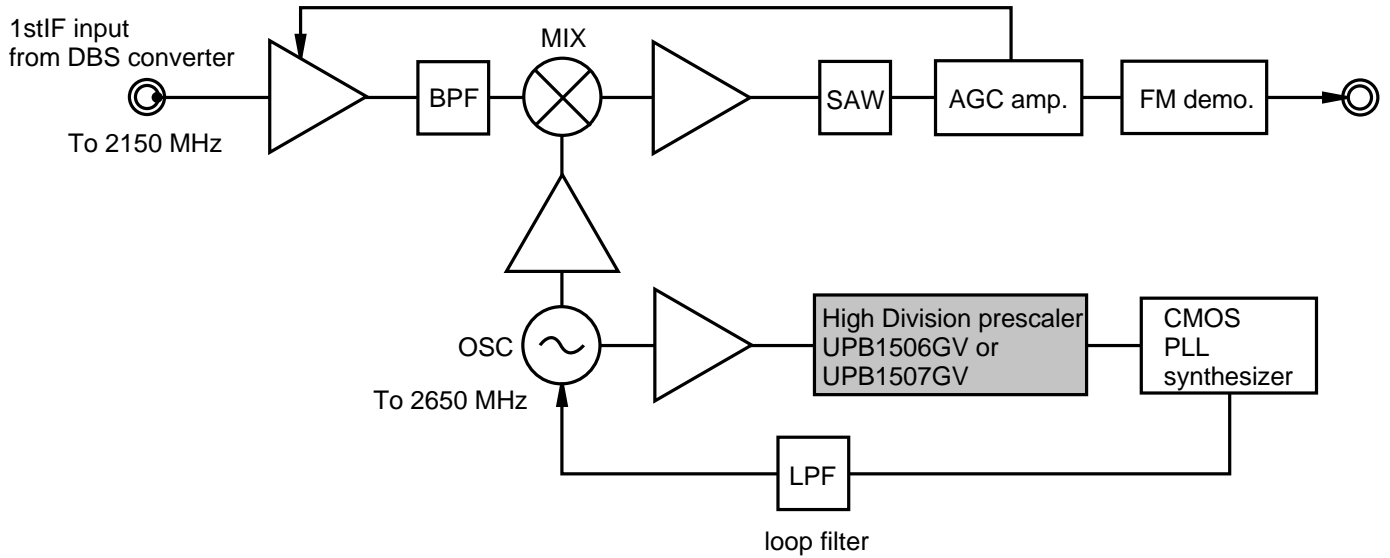

RF unit block of Analog CATV converter

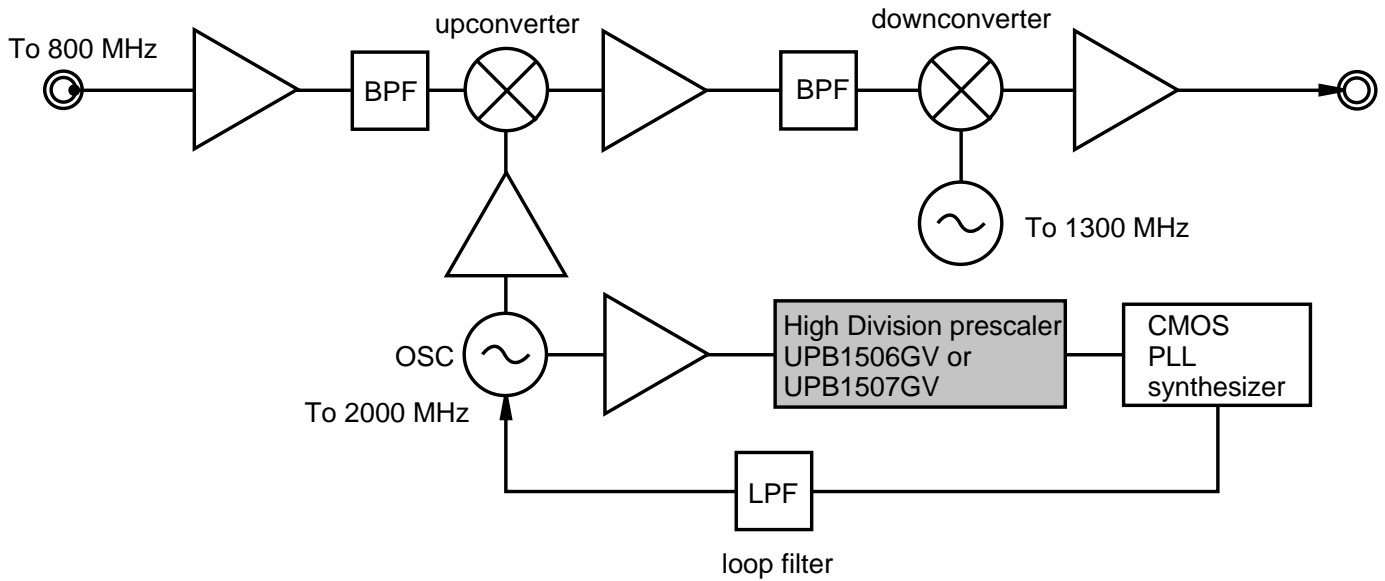

UPB1506GV, UPB1507GV

INTERNAL BLOCK DIAGRAM

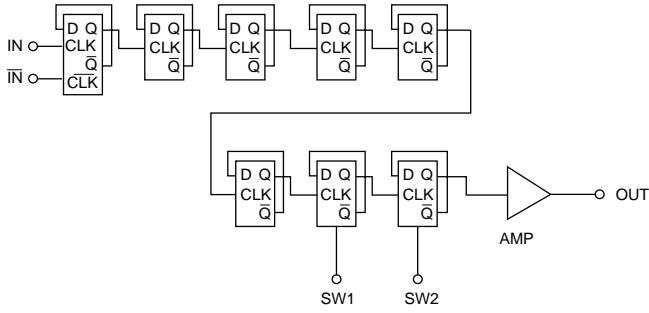

OUTLINE DIMENSIONS (Units in mm)

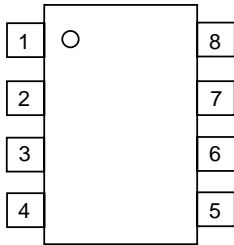
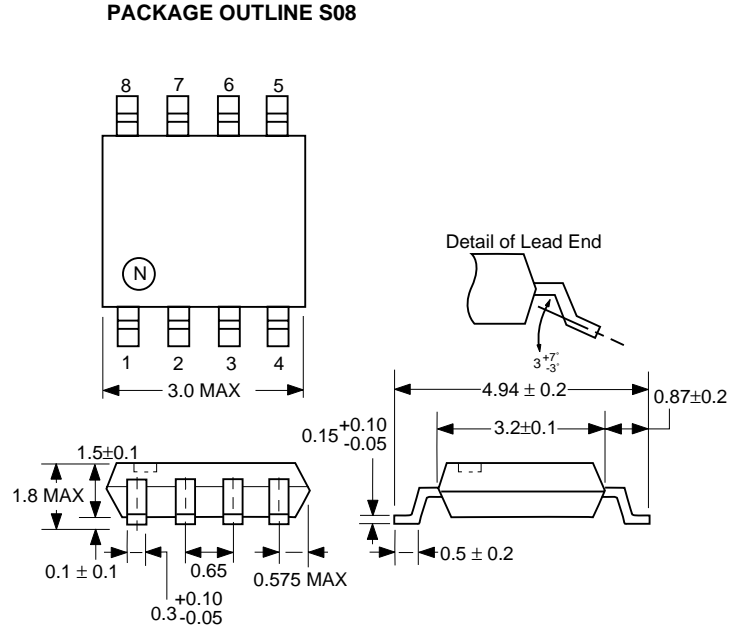

PIN CONNECTIONS

Pin No.	UPB1506GV	UPB1507GV
1	SW1	IN
2	IN	Vcc
3	IN-bar	SW1
4	GND	OUT
5	OPEN	GND
6	SW2	SW2
7	OUT	OPEN
8	Vcc	IN-bar

ORDERING INFORMATION

PART NUMBER	QUANTITY	MARKING
UPB1506GV-E1	1000/Reel	1506
UPB1507GV-E1	1000/Reel	1507

Note:

- Embossed tape 8 mm wide.
Pin 1 is in the tape pull-out direction.

EXCLUSIVE NORTH AMERICAN AGENT FOR **NEC** RF, MICROWAVE & OPTOELECTRONIC SEMICONDUCTORS

CEL CALIFORNIA EASTERN LABORATORIES • Headquarters • 4590 Patrick Henry Drive • Santa Clara, CA 95054-1817 • (408) 988-3500 • Telex 34-6393 • FAX (408) 988-0279
24-Hour Fax-On-Demand: 800-390-3232 (U.S. and Canada only) • Internet: <http://WWW.CEL.COM>

DATA SUBJECT TO CHANGE WITHOUT NOTICE

05/30/2000