

"Missions Edition"

LOW POWER RADIO

BROADCASTING

*How To
Start Your Own Radio Station*

© copyright 1990
by
James R. Cunningham

PUBLISHED BY:
JAMES R. CUNNINGHAM
P.O. BOX 8
STONEWALL, OKLAHOMA 74871
The United States Of America
Telephone: [405] 265 - 4496

Revised Feb. 1994

**No part of this Book may be reproduced in any form
without the written consent of the Author**

COPYRIGHT 1990



by JAMES R. CUNNINGHAM

TABLE OF CONTENTS

CHAPTER ONE	PAGE NUMBER
Field Strength Limits	4
Definitions	3
Leaky Cable	5-6
Campus Antenna System	7
How To Find A Frequency	8
MINI STATIONS (AM & FM)	9
Bill Board Antenna	10
CHAPTER TWO	
100 milliwatt Stations	11-18
100 mw Transmitter Schematic	14
CARRIER CURRENT	19-40
Phone line automation Device	25
Carrier Current Tuners	29-36
Field Strength Meters	38-40
CHAPTER THREE (Foreign Broadcaster Info.)	
Wire Antennas and Ground Systems	41-64
The Folded Unipole	44
Dipole Directional Antenna with 2 elements	47
GALCOM DDRR "Missionary Special"	48-49
"Grounding Hints"	50-53
49 to 160 meter vertical mast antenna	54-55
three element wire antenna "Super Directional"	56
Wire Antenna Radiation Patterns "SIMPLIFIED"	59
AM Antenna Tuner Info.	60-64
CHAPTER FOUR	
How To Decide Between AM or FM	67-72
Basics of Low Power FM Licensed Stations	71
SCHEMATICS (Transmitters)	28, 37, 73, 74, 75, 76
CHAPTER FIVE	
CONCLUSION - KITS - COAXIAL FM ANTENNA	84-90
HIGH GAIN FM STEREO BEAM ANTENNA	91-92

DISCLAIMER

The F.C.C. in Washington, D.C. is concerned about violations of its Rules And Regulations regarding Broadcasting. Interference to any Licensed Broadcaster is ILLEGAL and is punishable by Fines, forfeiture of Equipment and Prosecution. Interference with Aircraft Communications, Land Communications or other Licensed Services, by Clandestine Broadcasters is Illegal.

The Author can not be held responsible for those who seek to use the information contained within this Book in any illegal manner. Every reasonable attempt has been made to clearly outline the parameters of Low Power Radio for the Community and Minority Broadcaster who desires to use Carrier Current or Micro-mini Techniques. Due effort has been put forth herein to present in simple terms the facts as they now exist, concerning Low Power Radio, both for the Citizens of The USA and the Foreign Broadcaster.

Certain Ideas and Drawings presented herein are intended for "International" use and do not apply to the USA and Canada. The Reader assumes ALL RESPONSIBILITY FOR HIS ACTIONS and agrees to comply with all Laws within his State or Country and can not hold the Author responsible for any mis-use of printed data or information herein.

The Schematics herein have all been Field Tested and are certified operational and functional if assembled according to good Engineering Practices.

Certain items herein may be purchased from the Author for use within the USA, while others may be purchased "FOR EXPORT ONLY" by the Buyer.

The Author's intent is primarily to assist the "Missionary Broadcaster" and other Individuals who wish to be involved in "Ethnic" and "Minority" Broadcasting.

The use of any information derived from this Book is solely the responsibility of the "user." Check with the Governments Involved before building a Radio Station. In the USA, check with the F.C.C. at (202) 653-7313 or 254-9570.

Dedication

This Book is dedicated, first of all, to my Parents, who brought me up to fear God and have respect for my fellow man.

Then, to all who have assisted me in my learning and experiments, especially my wife Mary, who has put up with all my electronic junk in every corner for so many years.

I wish to express my appreciation to Mr. Armstrong, my Radio Shop teacher, who honored me above all his other Students at FOHI, and gave me nearly a pickup truck load of electronic tubes and components, which I am still using today (after more than 30 years). He told me that I was the only Student he ever had that would use the electronics "for sure." Mr. Armstrong, you were right. Thanks for the surplus components!

My thanks to my nephew Steve, who has assisted me in some of my experiments and helped out in many ways through the years.

My thanks to everyone else who has prayed for me and believed in my "projects" even when things seemed too impractical to ever pan out.

Finally, this Book is dedicated to the poor and disfranchised, who (hopefully) after using the information contained within, shall be able to enter the field of Radio Broadcasting and face tomorrow with renewed hope and expectations.

JAMES R. CUNNINGHAM
Author

DEFINITIONS

1. CARRIER CURRENT BROADCASTING

A. CARRIER CURRENT BROADCASTING IS THAT FORM OF BROADCASTING WHICH OPERATES AT ANY POWER LEVEL UP TO AND INCLUDING 50 WATTS. WHAT MAKES CARRIER CURRENT BROADCASTING UNIQUE IS THE FACT THAT IT RELIES COMPLETELY ON THE HOUSE WIRING FOR ITS ANTENNA SYSTEM. ANY USE OF AN "*INTENTIONAL RADIATOR" IS CONSIDERED ILLEGAL BY THE F.C.C. NO F.C.C. LICENSING IS REQUIRED FOR CARRIER CURRENT SERVICE.

B. CARRIER CURRENT OPERATES ONLY IN THE A.M. BROADCAST BAND BETWEEN THE FREQUENCIES OF 525 kHz and 1705 kHz. STANDARD F.M. BROADCAST FREQUENCIES FROM 88 - 108 MHz WILL NOT WORK WITH CARRIER CURRENT SERVICE, except for short distances (300 Feet Maximum).

C. A CARRIER CURRENT ANTENNA COUPLER IS NEEDED TO TRANSFER THE RADIO SIGNAL INTO THE HOUSE WIRING OR POWER LINES. WITHOUT THIS COUPLER, CARRIER CURRENT IS NOT CONSIDERED POSSIBLE.

LOW POWER BROADCASTING:

A. LOW POWER BROADCASTING IS GENERALLY AT A POWER UP TO 100 Milliwatts (.1 watts) using a maximum 10 ft. (3 meters) antenna wire or rod. This 10 ft. antenna must be built right onto the back of the radio. Coaxial cable from transmitter to antenna is STRICTLY LIMITED! No licensing with the F.C.C. is needed.

* INTENTIONAL RADIATOR:

AN INTENTIONAL RADIATOR IS WHAT YOUR 10 Ft. ANTENNA IS CALLED. Wire antennas, poles, or other structures used as an antenna system are called "INTENTIONAL RADIATORS" and are all limited to 10 feet maximum. The signal from 100 MW Transmitters usually reaches out about 300 feet or so and under the best conditions about 3 or 4 city blocks!

CAMPUS STATIONS:

A. Under F.C.C. Regulations, the Campus Station may use any kind of antenna needed to cover the Campus, but just 30 meters off Campus, the field strength must be at a minimum as described on the following pages.

Low Power Broadcasting

by

James R. Cunningham

In the Early Days of Radio, the FCC did not exist and many a Radio Station got started by making a home-made radio transmitter of 40 or 50 watts, putting up a wire antenna and doing business. In recent years, I met a man that began in business that very way. After his home-made transmitter burned down his "radio shack," he moved to Oklahoma and opened retail stores selling TV's and Appliances. The "seed money" for his successful businesses all came from his unlicensed Home Brew Radio Station. He never had a license, never dealt with the FCC, and never had anyone tell him he couldn't do it.

We have come quite a ways from "the good old days" when you could do as you pleased. These days, it is almost impossible to get started in low power Broadcasting. The FCC has enacted new Rules and Regulations in order to reduce interference levels in the A.M. Band for the benefit of properly licensed A.M. Broadcast Stations. A.M. Stations which are licensed by the FCC begin at 250 watts power and go up into the 50 KW. Range under certain conditions. If you desire to start a Station of 250 watts or more, you must go through all the Legal Procedures using a Consulting Engineer to do a Frequency Search, filing with the FCC and paying the necessary Fees and waiting for their approval.

EXCEPTIONS TO THE RULES

There are some exceptions to the general rules mentioned above. These include **CARRIER CURRENT OPERATIONS, COLLEGE STATIONS, BOARDING HOUSE STATIONS, REST HOME STATIONS, and Neighborhood Stations.** The level of Radiation is strictly controlled and limited, but can be enough to provide sufficient coverage. The **College Station** is a Model for the Rest Home, etc. In a College environment, the Students may build their own Radio Transmitter or buy an Approved Type. Various Antennas may be placed about Campus in order to cover all areas; but 100 feet outside the Campus Grounds, the Signal Level must comply to FCC Regulations of $24,000/f$ KHZ. at 100 feet. At the close of this Book, I also show techniques of Radio Broadcasting for use in Foreign Countries using low power Transmitters and long wire antennas!

The same Signal Strength Limitations also apply to Nursing Homes, Rest Homes, Apartment Housing, etc. In these cases, however, the Radio Station does not use and INTENTIONAL RADIATOR, but the wiring inside the house, apartment, etc. is used as the Antenna. If this is done, the FCC classifies the operation A CARRIER CURRENT STATION. In the case of a College Station, these are LOW POWER STATIONS, even though they may be Carrier Current. College Stations are not supposed to compete with Licensed Stations, and everything must be "verified" by Records kept in a Public Access File at the Station's Office. Any power may be used, any kind of transmitter and antennas needed to cover the Campus, but just 30 meters (100 feet) outside the Campus Grounds, the Field Strength must be limited to $24,000/F$ KHZ. Harmonics must be measured up to 30 MHZ and corrected if excessive. College Campus Stations are not to exceed 250 Microvolts of RF Feedback into the Power Lines. If CARRIER CURRENT is used, these guidelines do not apply. In any case, the RF Limits set by the FCC are not to be exceeded at 30 Meters outside the Campus Area. Filters may need to be installed to keep the RF down to legal limits where the transmitter connects to the Power Lines, in the cases where small INTENTIONAL RADIATORS ARE USED.

If a College Station uses the in-house wiring as an Antenna, they may feed as much power into the lines as is necessary to do the job, but at 100 feet outside the Campus, the Signal Strength must drop to below $24,000/F$ KHZ. The maximum amount of power normally permitted for CARRIER CURRENT is 50 watts, however COLLEGE STATIONS are allowed almost any power transmitter, any style antennas, etc.- but! Just outside the Campus, at 30 meters, the signal MUST comply with the Legal Limits set by the FCC! "VERIFICATION" can be done by a Certified Broadcast Engineer, or any other qualified person using a "calibrated" Field Strength Meter which is of the type Approved by the FCC.

There is also another application for Low Power Broadcasting inside the AM Band. This is inside Tunnels, Caves, Mines, or Buildings. A special "LEAKY CABLE" can be used, having controlled radiation characteristics. You may feed up to 50 watts RF Power into the System as long as Radiation LIMITS as stated above are not excessive at 30 meters outside the Tunnel, Mine, etc.

CARRIER CURRENT BROADCASTING WITH BURIED CABLE

If you should decide to use the buried cable method, you need to understand all pros and cons. Using this method, you are allowed to use up to 50 watts of power at any Broadcast Frequency where interference with other services does not occur.

The cable is actually a special 50 ohm coax with characteristics which allow radiation at a controlled amount. When this cable is buried 15 inches or so, the radiation is such that if you are nearby, you can receive the signal on a Standard Broadcast Radio. Visitors to the famous Carlsbad Caverns are given a radio after having paid the entrance fee, and as the Visitor walks along, various transmitters operating with recorded audio explain the Cave's Formations. If you are near a certain area of the Cave, your radio will receive only audio for that area. As you go along, the new areas are explained with a signal coming through a cable buried under the walkway. There are three ways to adjust the power in these cables. The first is: **DEPTH OF BURIAL - the deepest being 20 inches for a weak signal and right on the surface for maximum.** The second is: by a **POWER LEVEL CONTROL ON THE TRANSMITTER.** The third method is: **AN ATTENUATOR IN SERIES WITH THE LINE -** this method is seldom used.

At the end of the 50 ohm special cable is a **TERMINATING RESISTOR** having the characteristics of a small **DUMMY LOAD (non reactive) at 50 ohms.**

Andrew Corporation makes and sells this cable (current price is \$3.20 per foot). As you can see, this is rather expensive, but meets the FCC's requirements. This same cable can be put beneath the baseboard, inside ceilings, along sidewalks or mounted with fasteners along walls inside or outdoors. At any point along the cable, listeners will be able to pick up your signal. As stated, the radiation characteristics are controlled and you may run up to 50 watts per system. The Andrew Number is: **RX4-3A. 1-800-255-1479.** The terminating dummy load is: **#32299-6 with "N" plug for \$90.00.** Radiation is limited to **24,000/f at 30 meters from this cable!**

CONTROLLED CAMPUS ANTENNA SYSTEM

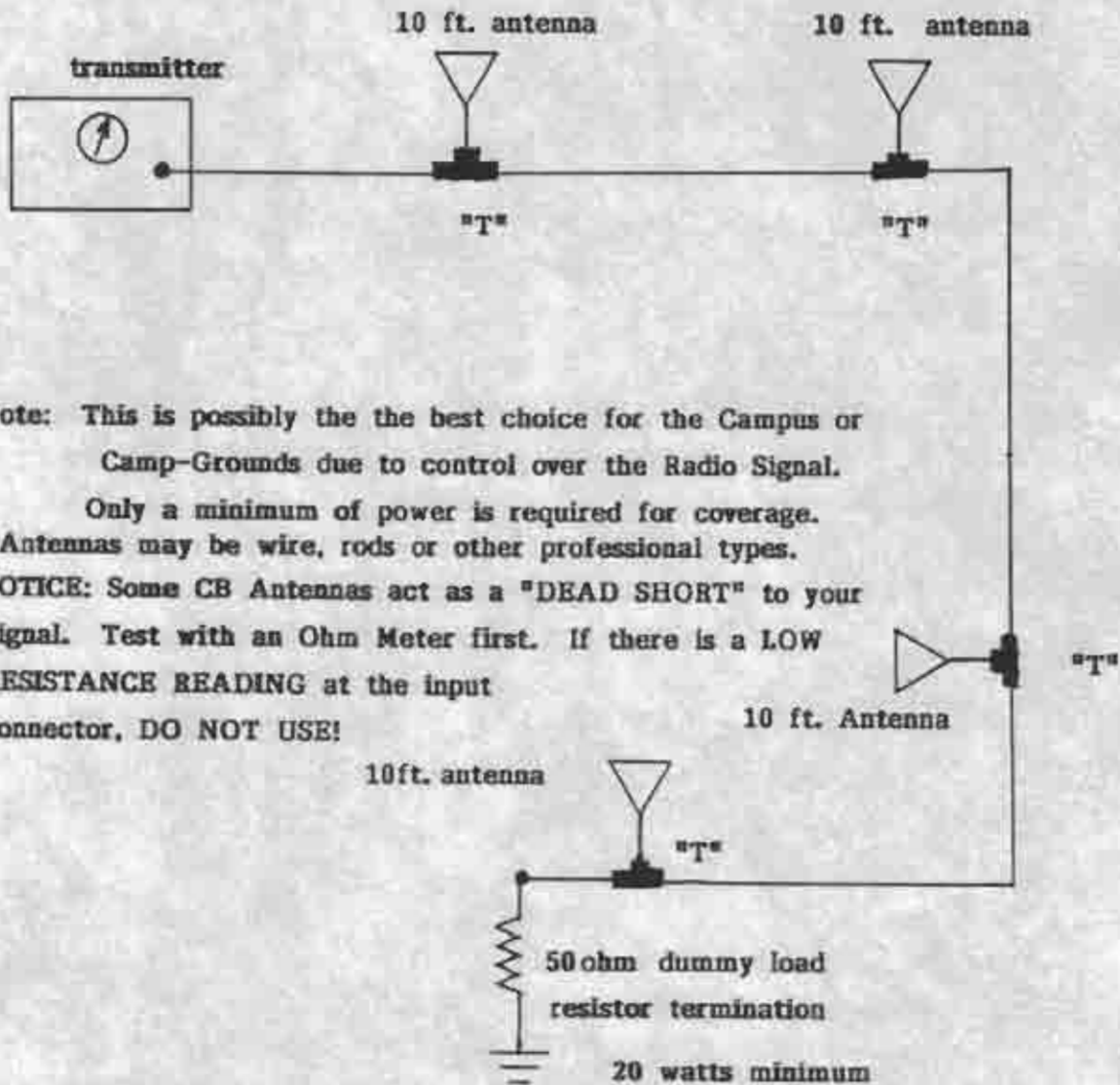

Note: This is possibly the the best choice for the Campus or Camp-Grounds due to control over the Radio Signal.

Only a minimum of power is required for coverage.

* Antennas may be wire, rods or other professional types.

NOTICE: Some CB Antennas act as a "DEAD SHORT" to your Signal. Test with an Ohm Meter first. If there is a LOW RESISTANCE READING at the input connector, DO NOT USE!

THE SYSTEM

Every 50 to 100 feet, a "T" is placed in the RG-58U Coax and a ten foot antenna is set in place to provide enough coverage for the Campus. The resistor load at the very end of the coax is necessary to prevent distortion. Use as many ten foot antennas as is necessary to cover the Campus. [PARTS: "T" - Radio Shack #278-198, Coax - R.S. # 278-1326, Load - Heathkit #HN-31-A (1-800-253-0570) and end Connectors - Radio Shack # 278-188]. Place antennas out of reach.

HOW TO FIND A FREQUENCY

The single most important thing you need to know is THE RIGHT FREQUENCY of operation for your Radio Station. In the world of HIGH POWERED STATIONS, this is difficult to ascertain, requiring expensive studies by experts, however this is not the case for your LOW POWER STATION! Since most A.M. low power stations are not expected to reach out over a few miles in any direction, you do not need any expensive frequency searches to determine the correct frequency of operation -IF- you follow these instructions:

Instructions

Obtain a DIGITAL A.M. RADIO. You may either buy or borrow one for your frequency search. Do not use the old fashioned slider dial radios as these may give FALSE READINGS. A digital radio such as the SONY WALKMAN or one of the RADIO SHACK DIGITAL radios will do a good job.

START at the bottom of the Band (about 535 KHZ) and WRITE DOWN ON A PAD EACH QUIET FREQUENCY. Now, SELECT A FREQUENCY THAT IS IN THE CENTER OF TWO OTHER QUIET FREQUENCIES. EXAMPLE: 1230: Quiet, 1240, Quiet, and 1250 Quiet. YOUR BEST CHOICE IS 1240! If you hear a station on the frequency just above or below the frequency you want to use, you will not be able to reach out well with your signal. BLEED OVER MODULATION from that distant station will block your frequency, even when it is on an adjacent channel. For best results, CHOSE A CENTER FREQUENCY that is quiet on the upper and lower channels, so your station's SIDEBANDS will carry your modulation in a correct manner.

WATCH OUT FOR THESE THINGS

If there is a strong HIGH POWERED STATION NEARBY, where you are doing your frequency search, IT MAY EASILY PRODUCE SEVERAL QUIET SPOTS ON THE RADIO ON SEPARATE BANDS DUE TO HARMONICS and its strong sidebands. Be sure you have a QUITE FREQUENCY where there is LOW "S" on a meter. A distant "weak" station will show you what a low "S" should sound like. If there is total silence, you probably have tuned in a strong Harmonic, free of modulation. Avoid such frequencies as they will not work.

THE MICRO-MINI STATION AM AND FM TRANSMITTERS

Under Part 15 of the FCC Rules and Regulations, a person may operate a small transmitter without a license. Recently, the FCC has allowed for the use of various transmitters, so long as the Radiation Limits are not exceeded. Antennas connected by way of a coaxial cable have also been allowed, so long as Radiation is not excessive. The College Station is the Model, where any device may be used to cover the Campus, but just outside the Campus, at a distance of 30 Meters, the Radiation must be limited to 24,000/IKHZ. with the answer in MICROVOLTS PER METER - not millivolts!

THE FM TRANSMITTER

FM is generally preferred because of its higher quality audio. While the FCC encourages the use of units with a built in "whip" antenna, radiating less than 150 Microvolts at 3 meters, the "Model" Campus Station calls for permissible use of "other" Antennas, so long as radiation limits are observed. Don't be confused by the FCC's "metric" methods of measurements, as they are exactly the same as the old 24,000/fMHZ at a distance of 100 feet or 30 meters. Standardization of the Measurement Method is imperative.

SPEECH TRANSLATION UNITS

A speech Translator is usually a small unit used indoors or at a Stadium, where there are various languages being spoken and translated, by way of Micro-mini Radio. Persons are given a receiver which has several frequencies available - a different channel for each language. There are several Transmitters, one for each channel of transmission. These may be set to any unused FM Frequency, and are limited to 100 MW, but higher powers may be allowable if interference to Licensed Broadcasters does not occur. These are also made to use other Bands outside the 88-108 MHZ Range, and will be found in use at Multinational Events such as the Olympics or Religious Gatherings. The Sound Technicians and Engineers must comply with Regulations governing such transmissions.

BILL BOARD ANTENNA

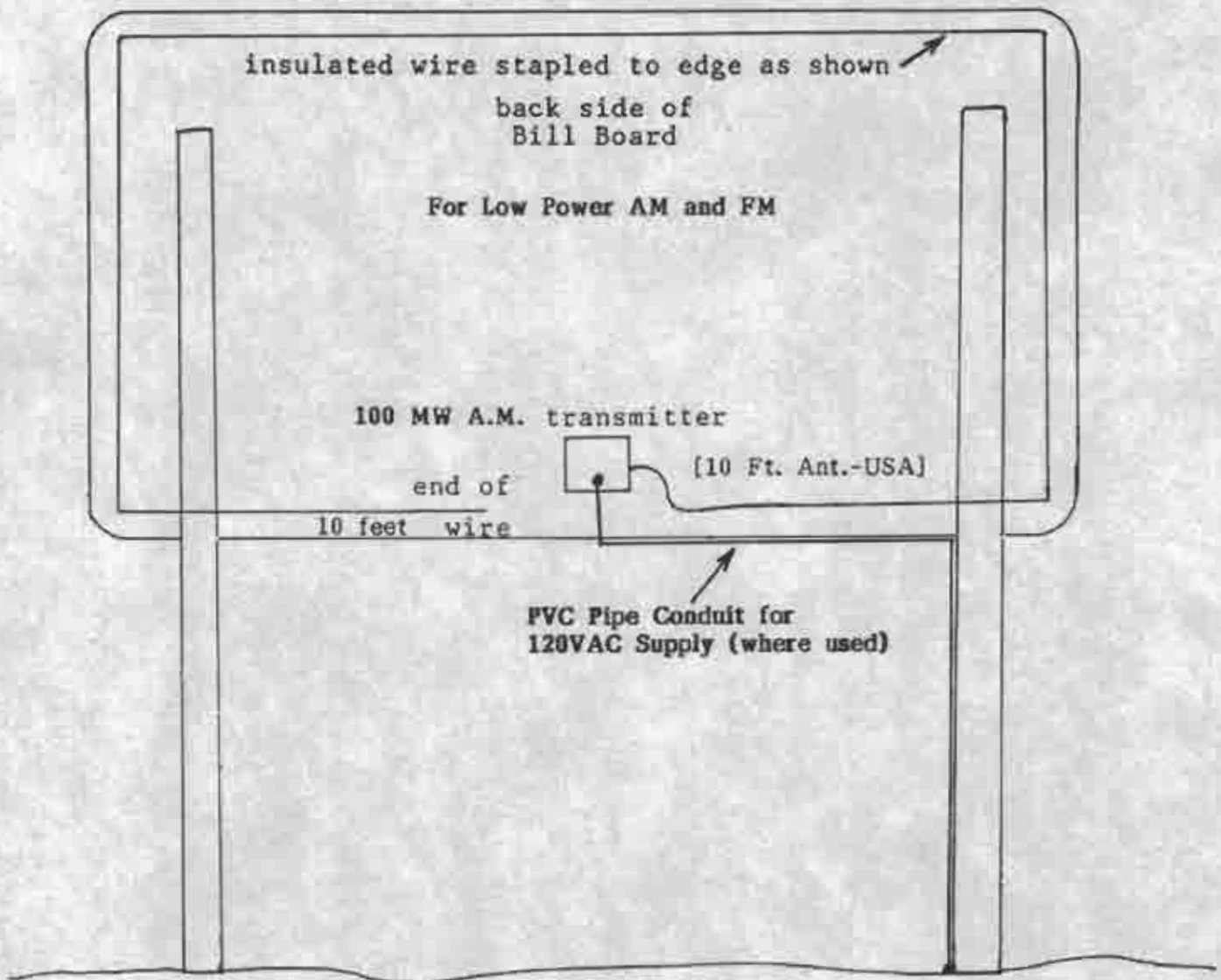

EXAMPLE

The Bill Board shown here is "A Talking Bill Board." Its 100 MW AM Radio Transmitter is powered by the Sunshine through a Solar Panel and a small Battery. The ten foot wire antenna is stapled to the back of the Bill Board and must not be bare, but insulated wire. If a frequency above one megaHertz is used, the signal will reach out a sufficient distance to be heard by slowly passing automobiles. Keep the sales pitch short and to the point. Some sort of endless tape player must be used for the repeating message, unless the microchip player is built into the Unit. FM works the same way. Use a small "whip" antenna or about 3 feet of wire for the antenna. This principle can be used for "Talking Vans," Houses or anything else with a message to deliver to the Customer.

ANSWERING SOME OF THE QUESTIONS
Chapter Two
The Unlicensed Station
AM Radio

There is no age limit placed on the building and operating of a **LOW POWER** Station. Any person desiring to do so may build and operate such a Facility. The Rules governing profanity, decency, and all Civil Laws must be obeyed. A School Boy or a Grandpa, the FCC does not require a certain age, nor does it require any Licensing or notification of the existence of your operation. The Station you build may be extended to cover many blocks or it may cover only an Apartment Building, School, dormitory, or small community. I will give you some ideas on how you may also get into Cable Broadcasting.

The FCC Rules (Part 15) deal with your operation's power, field strength, and harmful interference to public safety, and other Broadcast Stations. Stiff fines may be imposed by the FCC if these Regulations are not observed.

You may build all of your own equipment or buy it from others. Home style recorders and hi-fi equipment may be used for your Studio. Radio Shack provides smaller mixer boards that are perfect for Carrier Current operations.

Usually, you will have to figure it all out for yourself or hire a consultant costing hundreds or even several thousand dollars to find the answers to the tough questions. I will answer some of these questions and perhaps save you both time and money.

The reason the FCC stipulates a ten foot antenna length is because it is virtually impossible to get a ten foot antenna to radiate too much power even if you over drive it. The antenna length itself helps regulate the distance you will reach out with your signal and helps protect other Broadcasters from any interference you may generate. If this sounds discouraging, it is meant to be! No one in his right mind is going to attempt to broadcast with .1 watts and a ten foot antenna unless he spends some thought and careful planning in creating his whole operation. In other words, **you have to do it right or it won't work!**

These problems can be overcome! You can do it if you have the time and the persistence, and if you have the technical ability along with the other, you can't lose. In many neighborhoods, Radio Stations have actually begun in the manner I am about to outline in the following notes, and later gone up to full power after the money has started rolling in!

Yes, you can actually begin a legal broadcasting operation without a license in many areas. I suggest those in Ghettos, Barrios, and inner-cities looking into these possibilities in broadcast opportunities.

THE FREQUENCY TO USE

Your first decision is going to be on the choice of an unused frequency. There aren't any, but you can find a frequency that is impossible to pick up in your neighborhood on even a good radio. There will be any number of these, but if you intend to Broadcast **AT NIGHT**, BE PICKY because many stations come through like Gang Busters at night when you can't even find them during the day light hours! Find one where there is very little interference at night, or you won't be heard. This frequency must lie somewhere between 525 and 1705 KHZ in the A.M. Band. The lower frequencies usually reach out farther, but these are recommended only for carrier current operations and not for use with so called **INTENTIONAL RADIATORS** - that's what your 10 foot antenna is called by the FCC! Just find a frequency where there is very little interference and where you will not block out reception from any existing station - that is illegal and could get you into trouble real fast!

You can not - I repeat, can not legally use the city water pipes or even a loose wire laying around for a ground system. You have to use the case of the transmitter where it connects to the electrical wiring as a ground - that's all. You may be concerned about this, but really it is no problem at all since too much TV - Radio interference is created by people trying to get a good ground system at these frequencies, so in this case, you are best off to forget about special grounding schemes.

CALL LETTERS

You can not legally use Call Letters on any Unlicensed Radio Broadcasts or Transmissions. You must use your own distinctive Identification when Broadcasting, given at the top of every hour. This can be something like this: "99.1 OMB Campus Radio - your Campus Connection operating with a power of 100 Milliwatts in accordance to Part 15 of FCC Rules and Regulations."

Call Letters are assigned by the FCC only, for Legal Licensed Stations. You can apply for a Licensed Station using the FCC's Home Page: "<http://www.fcc.gov/>". You can go from there for much useful information.

YOUR TRANSMITTER

Your transmitter will have to be a very small item in order to operate at only .1 watts. You can build any number of them using the Schematic in this Book or invent your own, but be sure harmonics are down and that you have the Units all tested for Audio Response, Harmonic contents, Power Output, Frequency Stability, Etc. using calibrated test equipment. Many Bench Technicians have everything that is needed to make these tests. You will have to keep these records at the Radio Station Office or main transmitter site. You do not have to file with the FCC if you comply to all the regulations for this type station and keep all the records properly done on hand for inspection. All Field Strength Measurements must be made and recorded meeting FCC Limits.

The Transmitter, Antenna System and Audio System must be set up so that the Limits set by the FCC can not be violated by mal-adjustment. In plain language, you may not use a 25 watt transmitter set at 100 MW and be legal, because someone may adjust it up to an illegal power level. Your transmitter has to be capable of 100 MW and no more. Otherwise you can not use it.

You can use the output from an audio "Board" or mixer board and run it into your transmitter directly, but there should be a limiter in the system to prevent overmodulation - a source of radio interference and illegal bandwidth. You may build your own limiter into your transmitter or buy a limiter from any of the many suppliers of Radio Equipment.

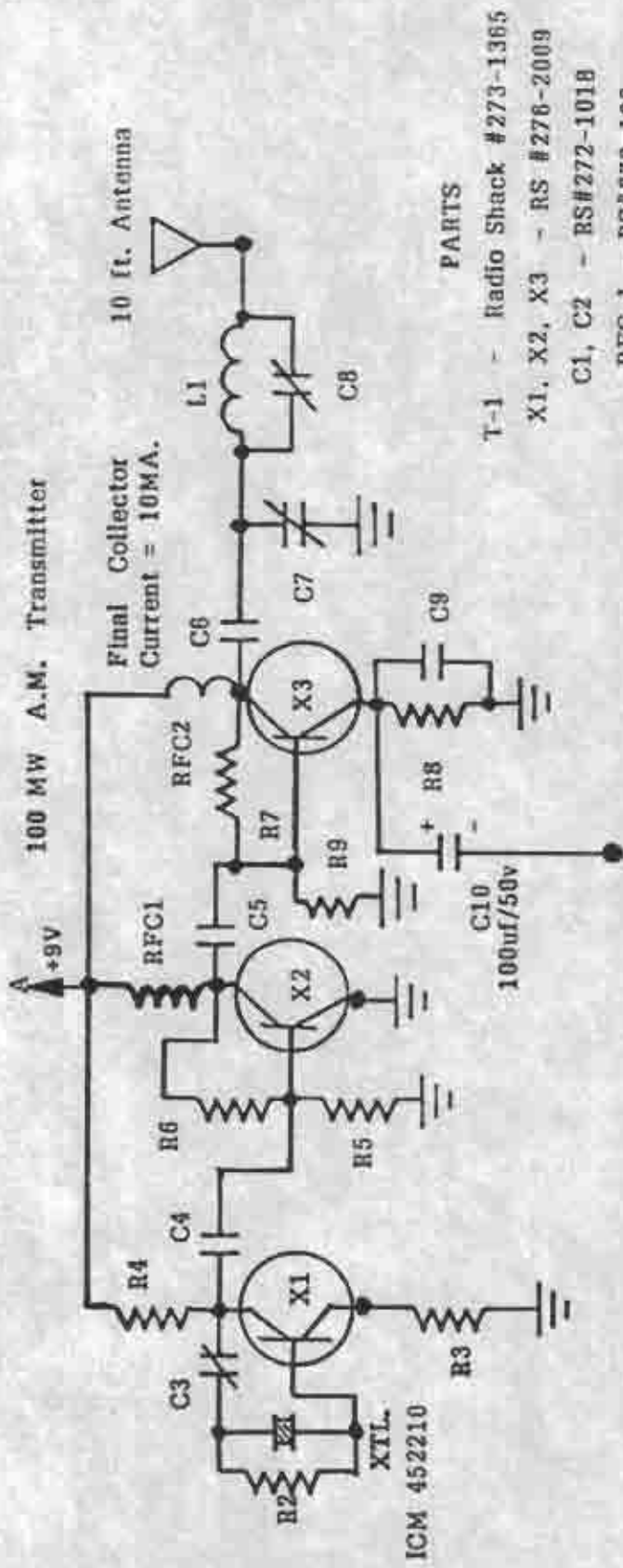

100 MW A.M. Transmitter

Final Collector Current = 10MA.

10 ft. Antenna

ICM 452210

PARTS

- T-1 - Radio Shack #273-1365
- X1, X2, X3 - RS #276-2009
- C1, C2 - RS#272-101B
- RFC 1 - RS#273-102
- RFC 2 - 2.5Mb choke
- C3, C7, C8 - RS#272-1336
- L1 - 200uh air coil or mini choke
- C9 - .2mf/100V.
- C4, C5, C6 - .001mf/50V.
- R7, R9 - 10K
- R8 - 330 Ohms
- R2, R6 - 1 meg
- R5 - 500K
- R4 - 10K
- R3 - 4.7K

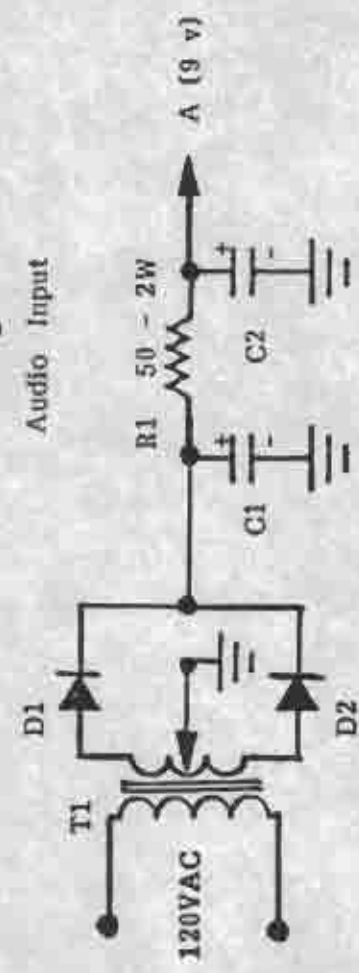

- INSTRUCTIONS:** Adjust C3 to exact center frequency
 Adjust C7 2 turns down
 Adjust C8 for best radiation results

Audio input is any from 8 ohms through 600 ohms at about + 6dbm.
 RFC 2 can be hand wound using magnet wire
 Antenna Tuning can be checked with an SWR Meter

Designed by JR Cunningham
 Tested 12-13-89 at 30Meters

HOW TO "TUNE" A TEN FOOT ANTENNA

In order to reduce harmful radiations (harmonics) from the ten foot antenna, you must find a way to tune it to resonance. Since the antenna is so tiny, it must be made to "look" like a larger antenna to the transmitter. If this is not done, you will generate a large amount of harmful radiation which will interfere with TV reception, Short Wave Radio Receivers, and Standard Broadcast Receivers in close proximity to your Station.

The simplest way is to build "A LOADING COIL" right inside the transmitter case. This should be a small RF Choke or Coil with a value of 180 micro henries to 200 micro henries. Across this coil, place a small **TRIMMER CAPACITOR** having a value of about 75 Pico Farads (the same as mmfd. or pf.) in the specification data.

TUNING

With the antenna in place, adjust the trimmer for maximum output at the antenna. You can set a radio having a built in "S Meter" nearby and adjust the capacitor for maximum deflection on the meter. If you can find AN **ADJUSTABLE 180 Micro henry COIL**, ALL YOU HAVE TO DO IS ADJUST THE **COIL IN THE SAME MANNER**, for maximum field strength on the Radio. In this case, NO CAPACITOR IS USED IN THE DESIGN. A simple schematic is shown below:



INCREASING YOUR COVERAGE

Sometimes it is possible to increase your coverage by placing your Antenna at a higher elevation, but this is not always the case because the short Antenna has a high angle of radiation to start with. This means that the signal tends to go up instead of out. By getting the Antenna **too high**, the only people who can get the signal are in airplanes! Elevating the Antenna is helpful in cases where there are interfering neon lights, traffic, or other sources of static. The Antenna does not need to be too close to static noise generators as mentioned.

CABLE SERVICE

Since you probably already have a cable TV and FM Service in the neighborhood, how about putting your new Station on Cable? The idea is to have the phone company run a high quality line from your Studio into the Cable TV Network. You pay the phone line rent and the cost of an FM Modulator and Fee to the Cable for use of their Cable System. Check on total costs first, then see if you can sell enough advertising on "your" radio Station to make a profit. If so, go ahead. Most FM Radio Cable Services (such as your's will be) make a pretty good profit each month. Your AM (**LOW POWER**) Station will be **ON FM** and will advertise itself two ways: (1) on AM and (2) on FM. Increased coverage means increased listeners and increased revenues. You should notice that in order to operate on Cable, you will need to choose an FM Frequency and an FM Modulator. The Technician at the Cable Company will give you the details and can help you locate the Modulator.

CREATIVE COVERAGE PLANNING

You can extend your **LOW POWER** coverage far beyond a 1 mile range through creative planning. You must have the consent of the neighborhoods involved, block by block. You will explain to them exactly how the system works, where the Antennas (several) will be and what service will be provided for the community. Then, the engineering takes shape into reality. The system works as shown on the next page.

**HOW TO BROADCAST LEGALLY WITH
100 Milliwatts**

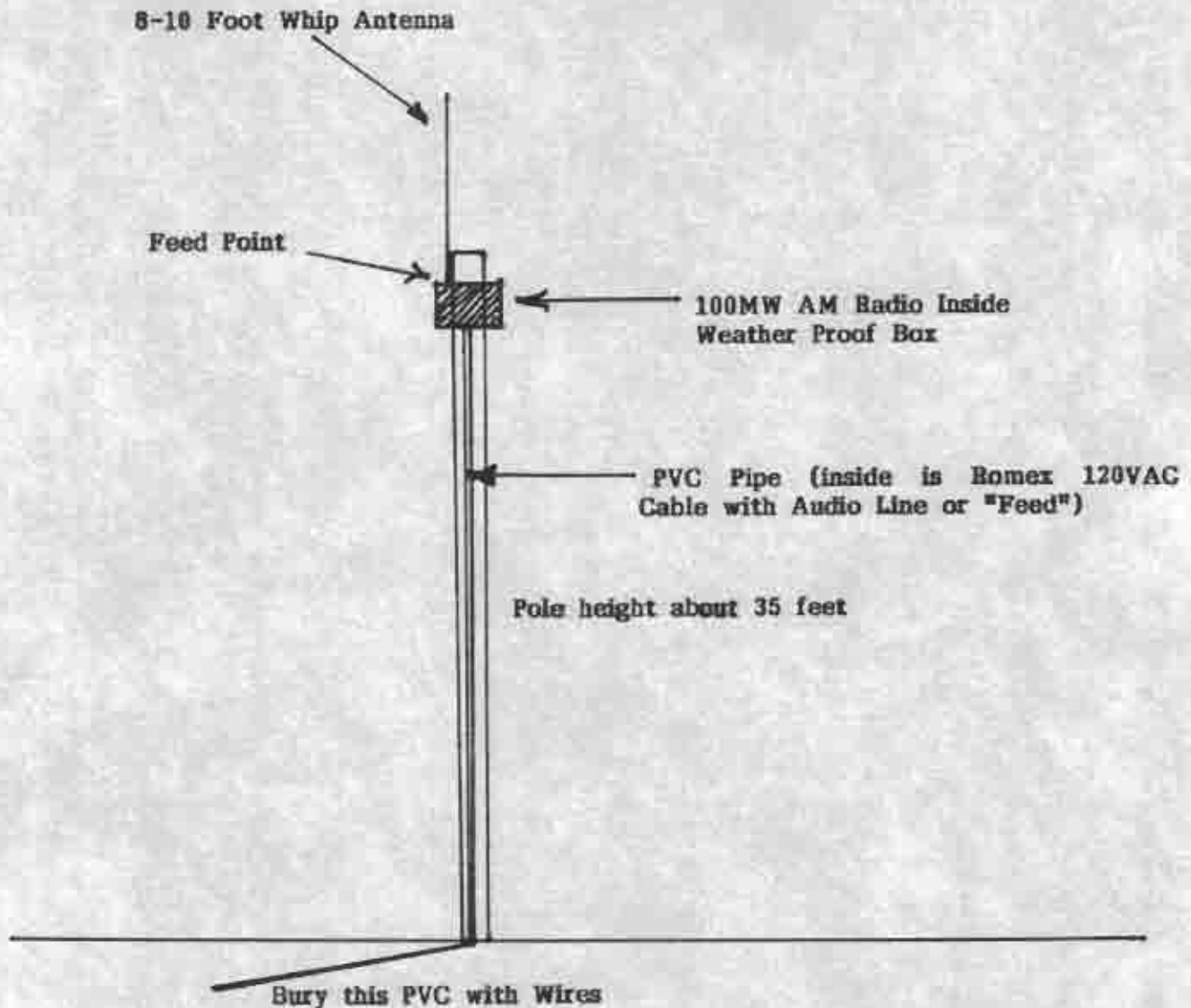

WHY IT WORKS

The SECRET to this Transmitter is the elevated Feed Point. No Ground Wire is allowed, but due to the height of the Enclosed Transmitter, 2 or 3 miles of coverage is reported. Use the Loading Coil Schematic and Transmitter as given in this Book. You can use this Legally in your own Installation, but BEWARE(!) of trying to sell them. You will need FCC Type Approval if you commercially sell these Devices. This Device is subject to all FCC Inspections and Orders. You must be prepared to demonstrate Legal Compliance!

INCREASING YOUR COVERAGE

Plan #1

First of all, the Offices of the Radio Station, the entire building may be strictly **CARRIER CURRENT** with a 50 watt transmitter coupled directly into the house wiring. This system should be thoroughly checked (verified) for complete FCC compliance and the records kept in a safe place in the Offices. At this point, your neighbors inside the Apartment Building, complex, or nearby Offices will be able to pick up your "Station" on the radio up to 100 feet away from the Transmitter Site at **LIMITS** or less signal strength. I'll explain later.

Next, you will need to extend your coverage by making or buying 100 MW transmitters, each with its own 10 ft. antenna. By the way, you can use a shorter antenna if you want, there is no law against it, but the 10 ft. version will work better except in cases where there is limited space.

Shown below are 12 city blocks represented by the squares. In between are the streets. The small black triangles represent five transmitters, each with its own 10 ft. antenna placed throughout the neighborhood and all fed by the same audio programming, either through rented phone lines or professional audio cable run about the neighborhood by permission of the owners or City Hall.

Each antenna is strategically placed and adjusted for correct FCC Specifications no matter where you are within the area. A man with a Field Strength Meter can determine this for you. All these Field Strength Measurements must be kept on file along with the name and address of the man doing the tests, the type of equipment used and its serial number.

Each 100 MW transmitter uses less current than a Christmas Tree Bulb, and helpful business people will allow you placement of transmitters in exchange for advertising on your Station. Since the Transmitters are small and use almost no electricity and cause no interference with existing Stations, there should be no objections to their placement, especially if you provide a needed service to your Community.

Note: All records are to be kept in your very own Broadcast Station Offices.

12 City
Blocks

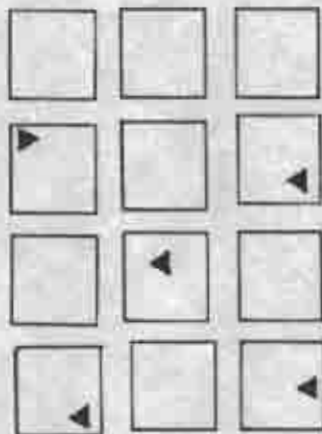

Each Antenna is powered by its own
100 MW Transmitter

Antennas must not be placed without permission of property owners. The more Community support you can receive, the more successful your Station will be. I would advise attending neighborhood meetings at the local YMCA, Senior Citizens Center, Club, or Churches and discussing this plan thoroughly before any action is taken outside placement of the Carrier Current System in your own "in house wiring." If anyone wants to hear your Station, they can drive by the front of your building and listen in on the Radio. You can explain how your Radio Station will serve everyone involved with Community Support, Ethnic, Cultural, and Business Promotion once it is in place - but you need their help to make it work. Public Service Announcements can be made in their behalf, Weddings, Funerals, Meetings, Partys, Etc. announced. Special Language Groups within inner cities could find this method of low power broadcasting exactly what they need to promote Family and Cultural awareness. News, weather and Sports of Local and National Interest could be broadcast, all in Native Dialects without the major expense of a full power Broadcast Station (which in most cases can not be obtained at ANY cost within the inner cities). Use your best imagination. How many NEW JOBS could this concept create for your friends or Family Members? Is this something that can help with everyday problems you and your neighbors face? I personally think that the inner cities need just such a system in many neighborhoods. Can you think of new ways to deal with crime, drugs, and child abuse using such a low power broadcast system? As long as you keep the system within the radiation limits, you can make it work at a very low cost. The electric bill will be the least expense of all for this kind of Station, instead of the greatest as is usually the case in Radio or TV.

CARRIER CURRENT NETWORK

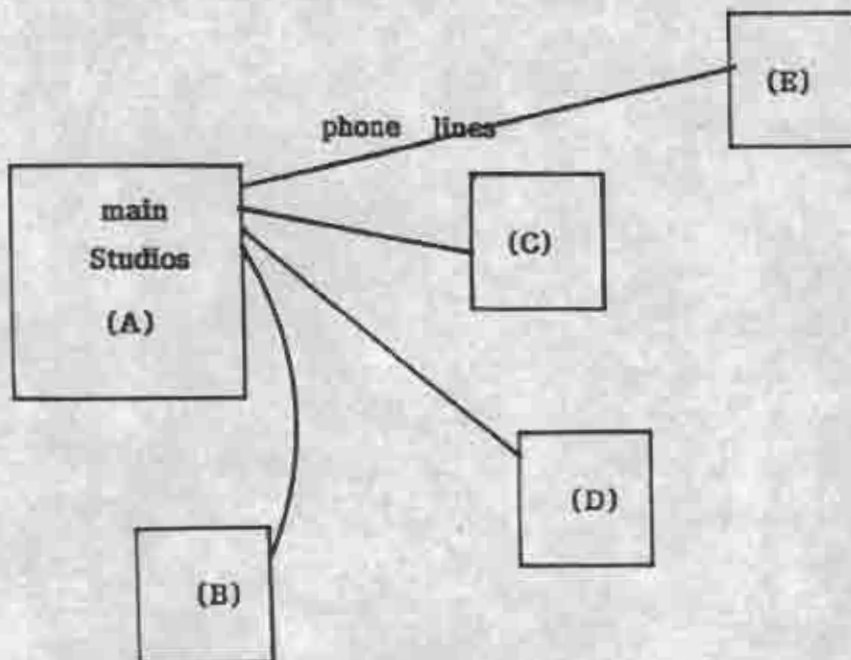

PLAN #2

The above illustration shows how you can build a Carrier Current Network using various Transmitters at strategic locations, all on the same exact frequency, and tied together using special phone lines. These phone lines provide the uniform Program Material for each of your Transmitting Units. With the radiation kept to proper levels, the signal can still be received without interfering with fully licensed Broadcast Stations operating under full power.

This information is given to assist Minorities, Ethnic Groups and the disadvantaged begin in Radio Broadcasting with a minimum of financial outlay.

The output from each Radio Transmitter is fed into the in-house wiring and Radiation Limits are observed according to FCC Regulations.

The Transmitters can be any wattage between 10 watts and 50 watts as needed to provide the correct amount of coverage.

PLAN #2 cont'd.

Plan #2 is the Plan 1 like the best because it uses more reliable transmitters and there is no hassle about trying to keep the Transmitter power down to .1 watts and no messing with ten foot antennas.

Plan number two works exactly like Plan #1 except it utilizes **CARRIER CURRENT TRANSMITTERS**, all on the same exact frequency and located throughout the neighborhood. You will put another Transmitter inside another Apartment Building, Business, Church or Club everywhere the signal becomes too weak to receive properly. There are **NO ANTENNAS**. The **HOUSE WIRING BECOMES THE ANTENNA**. This is called **CARRIER CURRENT**. The power lines will carry the signal up to several blocks around. The Transmitter power can be up to 50 watts in each location, but Radiation measurements must be made and kept on hand for inspection at your Studios showing that you are not radiating too much power at a distance of 30 meters from each radiation point (that's what you can call each Transmitter location).

Each Transmitter is fed the same Audio Programming through Special Telephone Lines used by permission of the owners or rented from the Phone Company. I will explain the **PHONE LINE SUBJECT LATER ON IN THIS BOOK**.

Your **CARRIER CURRENT TRANSMITTER** can be bought or hand made and it can be any power from a few watts up to 50 watts. In some areas, you will not be able to use a full 50 watts due to the excellent radiation the house wiring gives, but in other locations you will not get enough radiation with even a full 50 watts into the wiring system. It all depends upon the "**cut and try method**" which means you will have to try it and see what the results will be. In case the signal is too strong, you will have to find a way to turn it down. Most transmitters do not turn down, so you will have to spend time and money installing filters, etc. to reduce the signal level either before or after it enters the house wiring. The Transmitters I build all have a simple screwdriver adjustment which sets the power exactly where you want instantly! You can see on the front panel meter exactly how well the transmitter is operating!

50 WATT TRANSMITTER

Here you see an example of what my 50 watt A.M. Broadcast Transmitter looks like. It measures 19" wide by about 8" high by 12" deep. The Unit is capable of continuous operation at any power between 2.5 watts and 50 watts at 100% modulation. The frequency response is excellent. This Unit weighs about 15lbs. compared to those made by others weighing about 100lbs. The secret to light weight is the design using CATHODE MODULATION as opposed to Plate Modulation. This allows fewer components to give trouble, less weight and much more efficient operation. This Transmitter is designed using tubes instead of transistors because the Unit is used in areas of the World where transistors will not last due to power line surges. This transmitter will operate at voltages as low as 80 Volts and as high as 150 volts. Such surges are common in many areas of the world and will destroy hundreds of dollars worth of transistors

FCC
TYPE
APPROVED



within a few minutes time. My tube type Transmitter can take it all day long without any damage due to my special biasing circuits and self-regulating modulator design. The controls are simple: an On/Off Switch and a screwdriver operated Power Level Control as seen on the front panel.

The Unit should be used with a Limiter ahead of the Audio Input to prevent overmodulation as with any Transmitter. Signal Strength must comply with FCC!

With a number of these Transmitters operating in CARRIER CURRENT MODE as a Network, the needs of Ethnic Groups and Minorities can be served within the Inner City, Ghetto or Barrio. The Signal Strength must be measured to be sure it complies with the FCC Rules at a distance of 30 Meters from the Site.

RUNNING AUDIO TO YOUR TRANSMITTERS

You may run your own audio lines from your Studio across town with permission of the Property Owners, the City or other Authorities, or you may use the Phone Lines that already are in place throughout the area. Most likely you will be running some music through the phone lines into your Neighborhood transmitters. In order to do this, you must rent special **EQUALIZED LINES** from the Phone Company. You will need one phone line to each and every place you will have a transmitter set up. All lines will start at your Studios and feed the same thing into all the transmission sites. This can be expensive for .1 (100MW) transmitters, so I recommend forming your own **NEIGHBORHOOD RADIO NETWORK**.

THE RADIO NETWORK

You will operate several **CARRIER CURRENT TRANSMITTERS** into the wiring at strategic points in areas you need to cover by radio. These points will be in the attics, garages, or businesses of your friends and Business Partners. As an incentive to encourage neighbors to allow a transmitter on their property, you could give them a **trade out** for free advertising or other considerations. Another plan is to have 5 or 10 strategic locations where your transmitters will operate into the in-house wiring and make those individuals your **Board of Directors**. In exchange for membership on the Board, they pay phone line costs from the Studio to their transmitter and the electric bill. A written agreement must be signed and agreed to by all members. Then, you have something solid to base your business operation on. Board Members may also be granted advertising privileges for their Churches, Lodges, Businesses, etc. You work out the deal and keep everybody happy. The above idea would use **CARRIER CURRENT TRANSMITTERS EXCLUSIVELY**, no .1 watt (100MW) units. These will feed the in-house wiring and the Radio Signal will carry along the power lines throughout the neighborhood. Anyone with a radio will be able to get the Station throughout the region because you have filled in all the weak signal areas with another **MEMBER of the Team** with his own phone line coming from your Studios into another 50 watt transmitter.

There will be a monthly rental fee from the phone company for each of these special high fidelity **EQUALIZED LINES**. This kind of a line does not usually have a telephone attached to it on either end, instead it connects to your **AUDIO EQUIPMENT ON ONE END AND THE TRANSMITTER ON THE OTHER END**. It is used for no other purpose. You will have to talk to the Telephone Linemen or engineer in most Cities because most Office Employees will not know anything about **EQUALIZED LINES FOR RADIO BROADCASTING**. In the area where I now live, these lines rent for about \$40.00 per month. Some towns will be less and some a lot more.

You can get around this expense by using a device used by Radio Stations for Remote Broadcasts called **A REMOTE BROADCAST SYSTEM FOR PHONE LINES**. This type unit connects to any existing phone system by simply plugging it in. You dial the number where you want to send the audio. They lift the receiver or turn on the receive unit and the audio makes the trip using ordinary phone lines. The audio quality is not so good, but you can supply **YOUR OWN EQUALIZER** at the receive end to compensate for losses. I will show you how to build **YOUR OWN EQUALIZER** for this purpose and how to use it on the following pages. If you adjust the equalizer properly, you can get excellent audio quality over almost any phone line. As I said, Radio Stations use this system every day of the week all over America - or a slight variation thereof. The phone company usually gives no one any problem over its use. The circuits I will show are all **HOME MADE UNITS**. If you have the money, you may wish to buy Professional Equipment from one of the Dealers I list in the back of this Book. A Salesperson will explain each Unit they sell to you in detail, its advantages and its weaknesses.

THE SEND UNIT #1

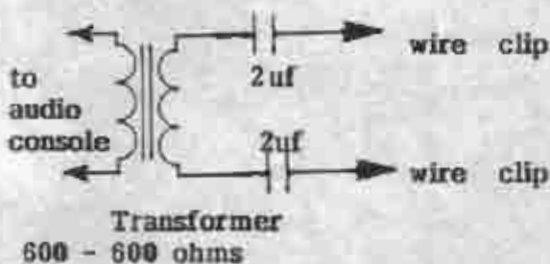

**TRANSFORMER: Radio Shack
#273-1374
Capacitors - #272-997**

HOW TO USE SEND UNIT #1

Using any telephone, dial the number where you want the audio to go. Then, after connection has been made, connect the two wire clips across the phone line and send the audio. This is usually done by unscrewing the mouthpiece from the handset and connecting the wire clips to the two wires inside the mouthpiece. If access can not be made this way, perhaps an adaptor can be purchased from Radio Shack or some other source to make connection to the phone line. Remember, this has to be done **after** the number has been reached, not before. A switch can be built into the unit so that after the number has been reached, the audio can be "switched in" without further delay. The two wire clips can be replaced using permanent connectors and a more elaborate looking "box" can be built using this same method.

CONNECTION TO THE OUTPUT OF YOUR BOARD

Hopefully, your mixer "Board" will have a 600 ohm line output. Use a couple of resistors (270—300 ohms, 1/2 watt) just ahead of the transformer to protect against strange variations in frequency response. If you feed two lines after the "Board" use a 600 ohm "splitter" as shown. If you feed more than 2 phone lines, you may need to invest in "A DISTRIBUTION AMP" with 600 ohm outputs. **These amps are made for Studio use.** If you can not find a distribution amp, you may need to use several small line amps after the Board to drive the phone lines. Your local Audio Dealer or Recording Engineer should be able to guide you in all this without a doubt.

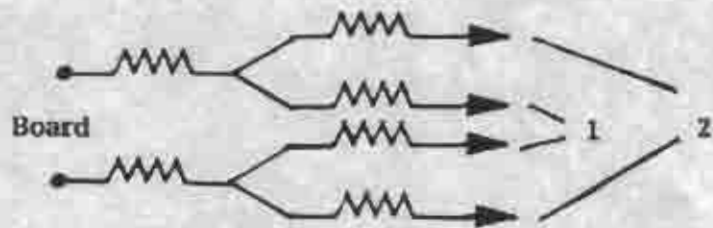
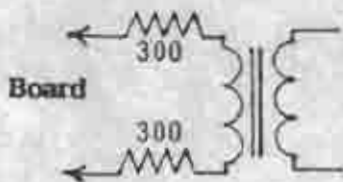

all resistors are 200 ohms each

THE RECEIVE END

You can build a device for the receive end that **ANSWERS ITSELF** and feeds the audio into the Transmitter. All you have to do is dial the number of your "Remote" and it answers allowing you to send the feed to the Transmitter.

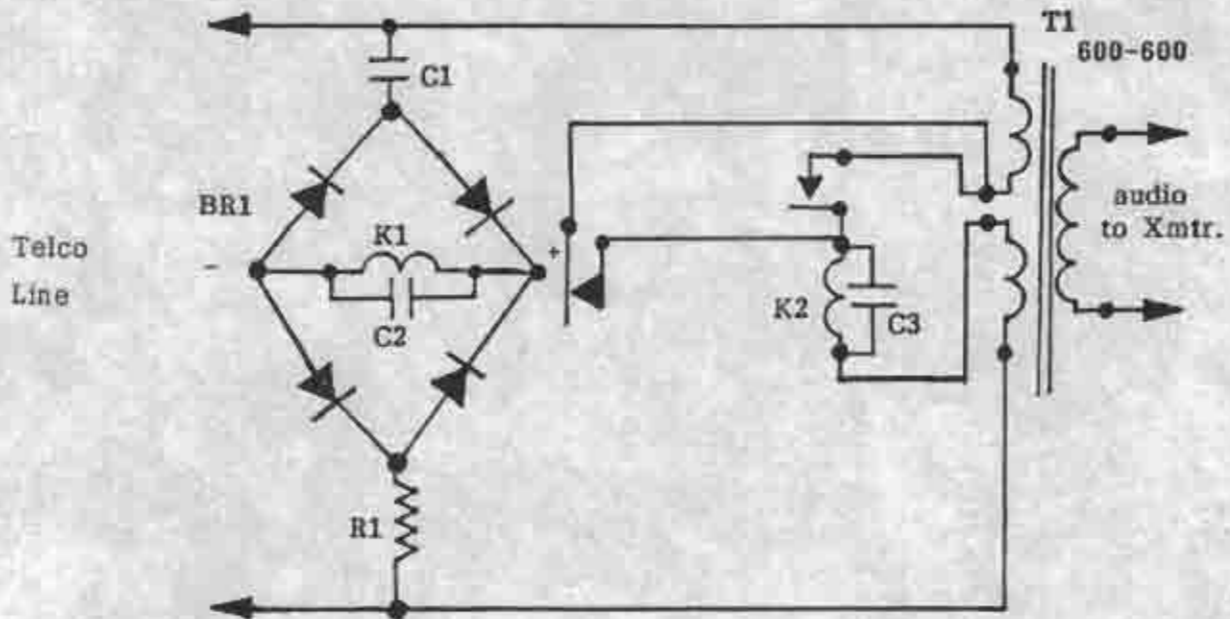

PARTS:

C1 - 3.3 mf non polarized, C2 - 1500mf/25V, C3 - .47mf/100V, R1 - 1200 ohms 1/2 W, BR1 - Bridge Rectifier ECG 5310 or Eqv., K1 & K2 - Radio Shack 275-004 9V coil/500 ohms, and T1 - Stancor A-4350 with split winding.

HOW IT WORKS

The ring voltage appears across C1, BR1, and R1. BR1 rectifies the voltage to DC, which appears across K1 and C2. K1 operates and is held by C2. K1 connects the upper coil of T1 to K2 and C3. The DC Phone Line Voltage causes K2 to operate. K2 contacts maintain the DC flowing in K2. The "Ring" pulses stop because K2 "answered" the Call. C2 discharges through K1 and K1 releases. C3 acts as audio bypass to keep K2 closed by the phone line voltage. C3 allows the audio to enter the primary of the transformer. When the Studio "hangs up" the Unit turns itself "off."

THE EQUALIZER

Using inexpensive parts, you can build a line equalizer as shown here in this schematic. Adjustment of the 500 ohm control will equalize the phone line. You may adjust your audio quality "by ear" or use special equipment for this.

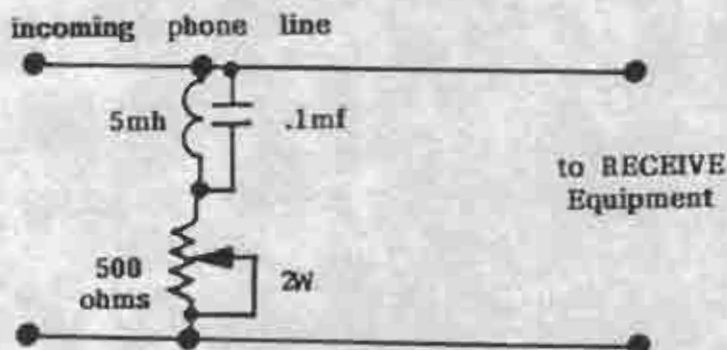

The frequency response at various frequencies will be affected by the setting of the resistor (rheostat). If you do not wish to buy the rheostat, you can make the adjustment by trying various values of 1 watt resistors (in place of the rheostat) until you find the correct value. Then, leave this value in the unit permanently. The unit stays in place in the line just AFTER the line terminals and before the receive equipment. The device that answers the phone call should be just ahead of (before) the equalizer.

PARTS SOURCES FOR EQUALIZER COMPONENTS

1. MCM ELECTRONICS - 650 Congress Park Dr., Centerville, OH 45459-4072
1-800-543-4330
[a] 5 mh choke part # J-50-395
[b] .1 mf capacitor/500 volts - #J-31-1630
2. Surplus Sales of Nebraska - 1315 Jones St, Omaha, Neb 68102
1-402-346-4750
[a] 500 ohm - 2 Watt Rheostat (ask for assistance)

HIGH FIDELITY RADIO TRANSMITTER

The Schematic shown on the following page can be built by an experienced Technician using standard parts. Parts can be obtained from the Suppliers listed at the back of this Book.

Technical Information

The chassis can be any size large enough to hold the components allowing enough spacing to make wiring easy. Too much cramping for space actually causes tuning problems and parasitics. At the base of each of the three 2.5 mh RF chokes, a .01/1KV bypass capacitor must be used, although these are not shown in the schematic. The Unit will work without these but there will be serious problems with tuning.

The power can be adjusted using the rheostat, and it should be possible to obtain a considerable amount of output power beyond the 10 watt range specified. The grid-leak resistor on pin 5 of the 6L6 will vary in value due to things affecting RF Drive level to the grid, such as spacing, variations in tube socket materials, etc. A value as low as 50K can be used in many cases. If there is a problem with obtaining proper output level from the Unit, this resistor may need to be changed to a lower value.

All capacitors should have at least a 600 volt rating unless otherwise specified. All resistors are 2 watts unless otherwise specified. The tuning coils L1, L2 - L3 are 60uh for L1, and 30uh each for L2 and L3. L2 - L3 can be a single 60 uh coil divided in half. These must be adjustable and usually are made so by using wire clips provided for the coils. Surplus Sales of Nebraska supplies these coils and clips (part # 3028). To tune the Unit, use a 50 ohm dummy load with a "T" and connect an oscilloscope to the dummy load. View the waveform for purity, height (power) and linearity. Once the coils are adjusted, modulation will be possible beyond 100 percent without distortion. If you experience problems in adjusting your Unit, consult your Local Ham Operator experienced in Kit Building. He may have to make the adjustments for you.

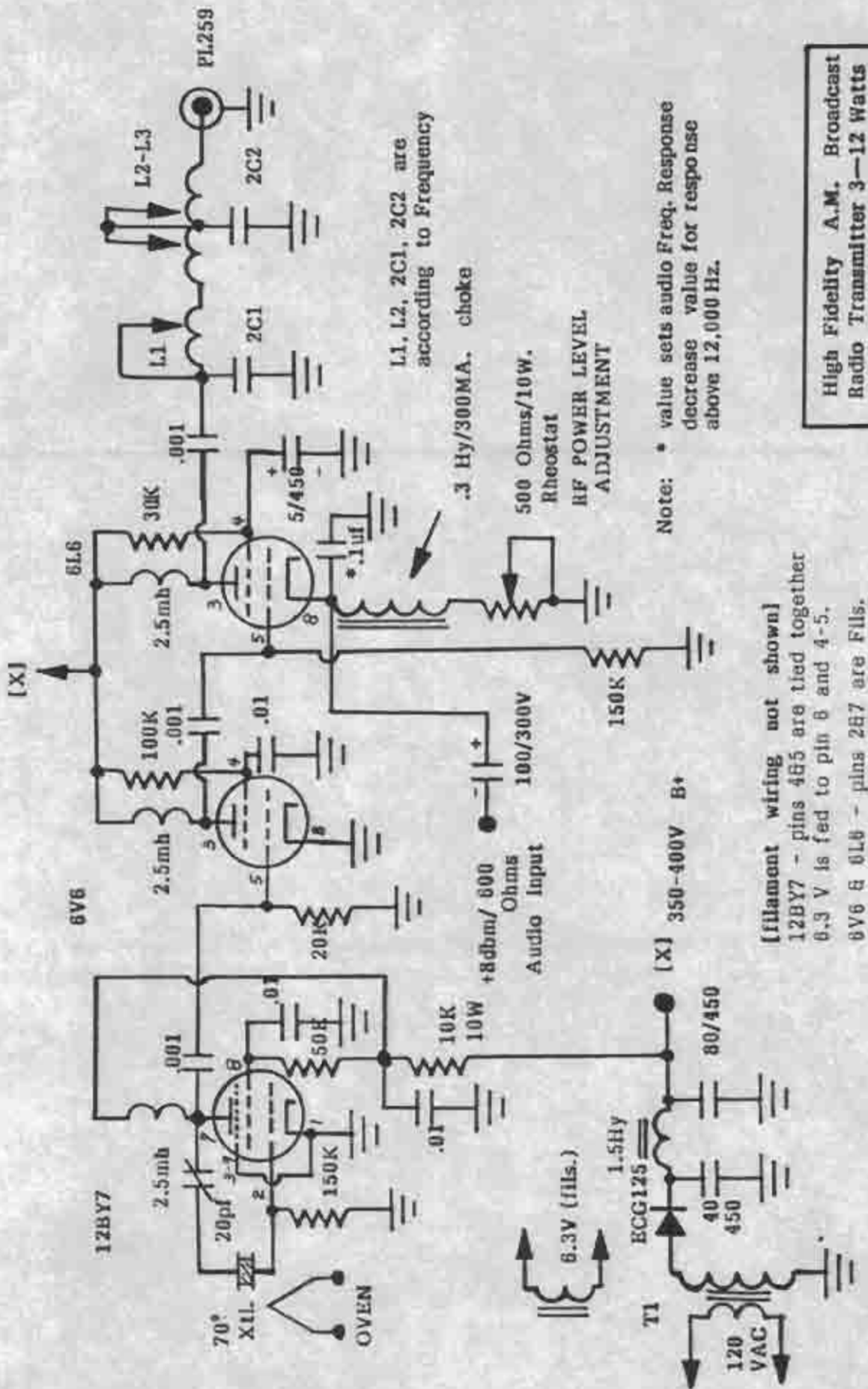

L1, L2, 2C1, 2C2 are according to Frequency

Note: * value sets audio Freq. Response decrease value for response above 12,000 Hz.

[filament wiring not shown]
 12BY7 - pins 4&5 are tied together
 6.3 V is fed to pin 8 and 4-5.
 6V6 & 6L6 - pins 2&7 are Filis.

High Fidelity A.M. Broadcast Radio Transmitter 3-12 Watts

Designed by
 JAMES R.CUNNINGHAM (C) 1989

use 3-5amp fuse
 T1 - 300-400 V Sec. 300MA



THE CARRIER CURRENT TUNER

The Carrier Current Tuner is used to "TUNE" your Radio Signal into the Power Lines so that you may Broadcast without any damage to your Radio Transmitter Equipment or needless interference to Radio-TV Reception in close proximity to your Studios.

CARRIER CURRENT (when set up properly) provides for humless high quality operation on the AM Radio Dial with ZERO INTERFERENCE to Licensed Services! CARRIER CURRENT makes use of the Near Field [INDUCTION FIELD] of the in house or Power Company wiring as an "ANTENNA." No Intentional Radiator is allowed, so that the INDUCED Radio Signal Travels along the pathway of the electrical wiring and does not radiate outwards from the wiring as in the case of an ordinary antenna system. In other words, as a person with a radio receiver departs from close proximity to the electrical wires containing the Radio Wave, the Signal is quickly attenuated! This Feature allows very close control over where the Radio Signal will be received! The Carrier Current Signal will be lost at a distance of 300 feet from the electrical wiring, in virtually every case, YET CLOSE UP TO THE WIRES [INDOORS OR ALONG STREETS WHERE THE WIRES GO] there will be a clear Signal! The Carrier Current Tuner makes all this possible, by putting the signal inside the Electrical wires by way of INDUCTION - ALMOST NO RADIATION! This is why the FCC permits CARRIER CURRENT BROADCASTING [no License required or available].

CARRIER CURRENT COUPLER

Where there is a need to couple the RF energy from your Radio Transmitter into the Apartment (or wherever) power lines, it is done as follows:

1. The output from your Radio Transmitter is run into a 50 ohm coaxial cable such as the RG-8 or preferably RG-58 type because of its greater flexibility and reduced cost. This is run to a place in the building central to the entire building for greatest coverage.
2. The circuit below is constructed in an aluminum box and the output from the box is connected to a three prong 120 VAC plug. This plug is simply plugged into the wiring and the capacitor adjusted for best results (this would be the strongest signal strength on your radio) and best audio quality. Just look at your Radio's signal strength meter and listen in while making these adjustments. Your Radio's Meter should show when best results are obtained.

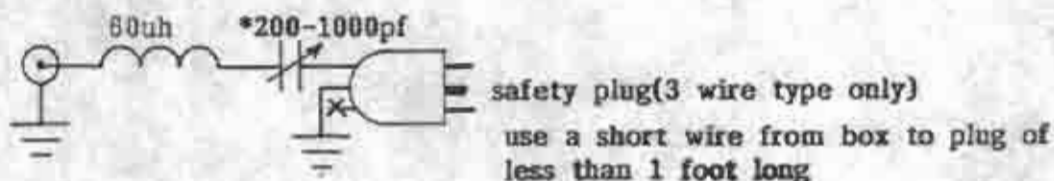

3. The 60 uh coil is constructed on a plastic PVC water pipe section 3 inches long by 1 inch outside diameter. The wire is #22-#18 gauge wound in several layers, one on top of the other. Leave at least 1/2 inch at each end of the pipe for screws which go into the center of the pipe and come out through spacers into the chassis. Nuts on the outside of the chassis hold the coil away from the metal and firmly in place. The coil will have 30-50 turns (2"x1.25" diameter).
4. The capacitor may be one of a fixed value with at least 600 volts Rating. Lower frequencies will use a value closer to 1000 pf (.001mfd.) and higher frequencies will be about 250 - 400 pf. Your capacitor should be A MICA CAP. OR CERAMIC type such as used by Ham Radio Operators in their equipment.

PLEASE REMEMBER! The largest amount of power the FCC allows you to run into your power lines is 50 watts. At 100 feet from the building, you must comply with FCC Field Strength Limitations for your frequency of operation.

THE CARRIER CURRENT COUPLER

Here you can see the kind of parts that should go inside a coupler for Carrier Current. Never use a cheap capacitor like your local Radio/TV Repair Shop will sell you. It will blow out your transmitter when it shorts out (usually within the first 15 Minutes). The mica Transmit Capacitor shown has a high amperage rating and is made for Radio Broadcast. Your local Ham Operator should know where to find bargains in this type Capacitor. You can make the coil yourself following my previous instructions.

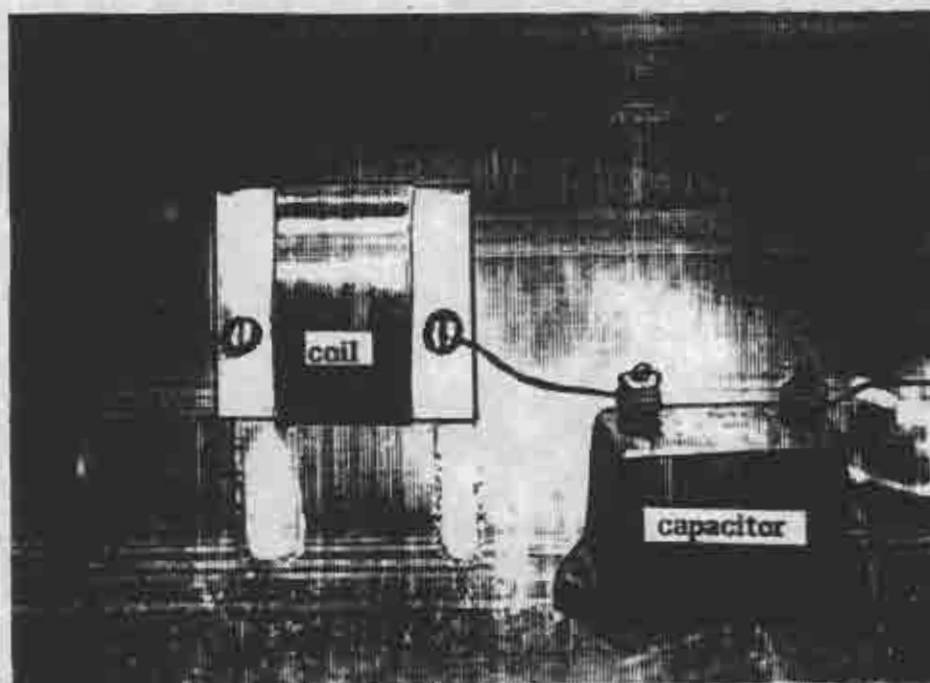

F2B 5000 volt Mica Capacitor & 60 Uh coil

The wire on the coil should be capable of handling about 3 amps and the capacitor should have at least a 6 Amp RF Rating at 1 MHz.

The capacitor is a non-adjustable type in order to make the installation affordable. The adjustable vacuum capacitors cost several hundred dollars each (used). By the "Cut and Try Method" you can find the capacitor value that works best. This value will be about .002 Mfd. at lower frequencies. You can use the "S" Meter on a Radio to tell when the best signal transfer is taking place or a special tuning meter can be used. I can also build these units for you.

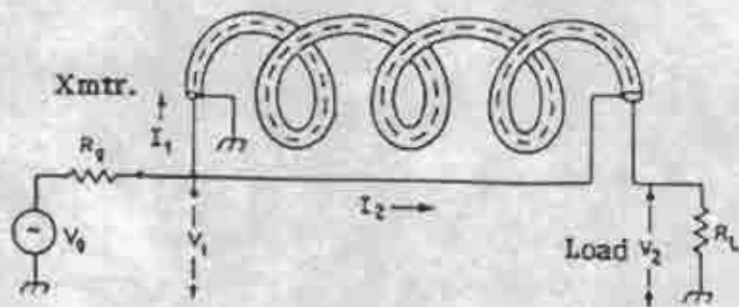

The schematic of a
4:1 coaxial-cable transformer

Reduces from 50 Ohms to 12.5 Ohms

TOROID COUPLERS

Toroid "cores" can be bought at various places. One of the Suppliers is listed on the bottom of the Page. Use Mini 50 ohm coax to make the combiner. You will need to make a total of (3) three of these as shown below. Simply wind 10 turns of mini coax around three separate cores, making three units as shown. Then connect the three units in **series** in order to achieve a very low output resistance. Most electrical wiring requires in the order of .3 ohms source in order to make a match.

A= shielded braid

B= center wire

5-8 turns is normal
in most installations!

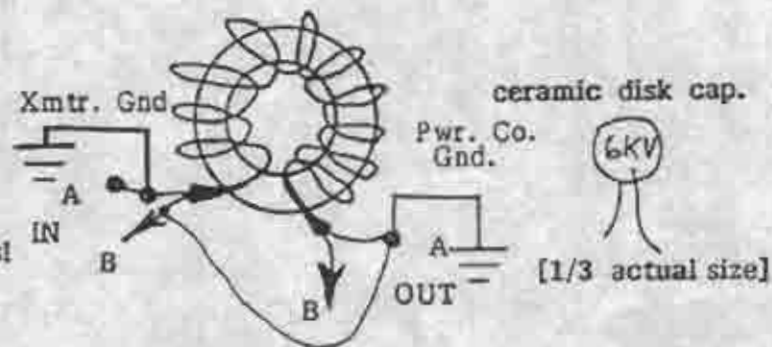

Be sure to use a **CERAMIC DISC CAPACITOR** about the physical size of a quarter (or larger) in order to provide isolation from the electrical power. You don't want to get shocked or do damage to your transmitter. The ceramic capacitor must have at least a 1,000 volt rating and can be just about any value, but the most common type is Radio Shack number 272-160 or equivalent. If these heat up, use two or more in **PARALLEL**. Toroid designs tend to be very "forgiving" so don't worry about a perfect "match", just try connecting to the AC Outlet or Breaker Box in your "location."

FERRITES

You may buy high quality ferrite cores from: AMIDON ASSOCIATES, 1-800-760-4429, N. Hollywood, CA 91607.

VITAL POINTERS

Many times the Carrier Current Installation will not work right. Since its ability to carry the signal out to any distant place is dependent totally on RF INDUCTION, instead of RADIATION, many complex factors can affect your signal!

CHOOSE THE RIGHT FREQUENCY!

The most common mistake made by the inexperienced Broadcaster is to choose the WRONG frequency. JUST BECAUSE A SPOT ON THE DIAL IS QUIET, DOES NOT MEAN IT WILL WORK! Here's why: There may be enough unmodulated RF present or AM noise to block your signal. At times this shows up as SILENCE on the radio receiver, but can be strong enough to prevent the effective use of that frequency. Check the quiet spot on the radio dial with a meter made for this purpose. A radio with an "S" Meter, such as the Realistic 400 Series is a good choice. If possible, use a Professional Field Strength Meter to determine the amount of noise and RF present on the channel you wish to use. If this is a low reading, both day and night, you have found a good frequency for Broadcasting.

The use of wire antennas, shown in this Book, are for the International Community and can only be used on the "Amateur Bands" here in the USA! These must have low "SWR" and good tuning in order to operate properly. This is covered later on in the Book. Most of these designs work best at heights above 20 feet, with one exception which is illustrated as the "Galcom" Antenna.

CARRIER CURRENT IS NOT AN EXACT SCIENCE! If it doesn't work out well the first time, try, try again! There are areas where the Power Company's Equipment simply blocks all Radio Signals, but other areas exhibit remarkable distances! Many times, a move across the Street or Town is all that is needed to correct a coverage problem with Carrier Current.

Beware of RF BURNS! Your transmitter can produce high RF Voltages at the Carrier Current Coupler Unit, feedlines, or inside. RF Burns do not heal quickly and seem to be much more painful than ordinary burns.

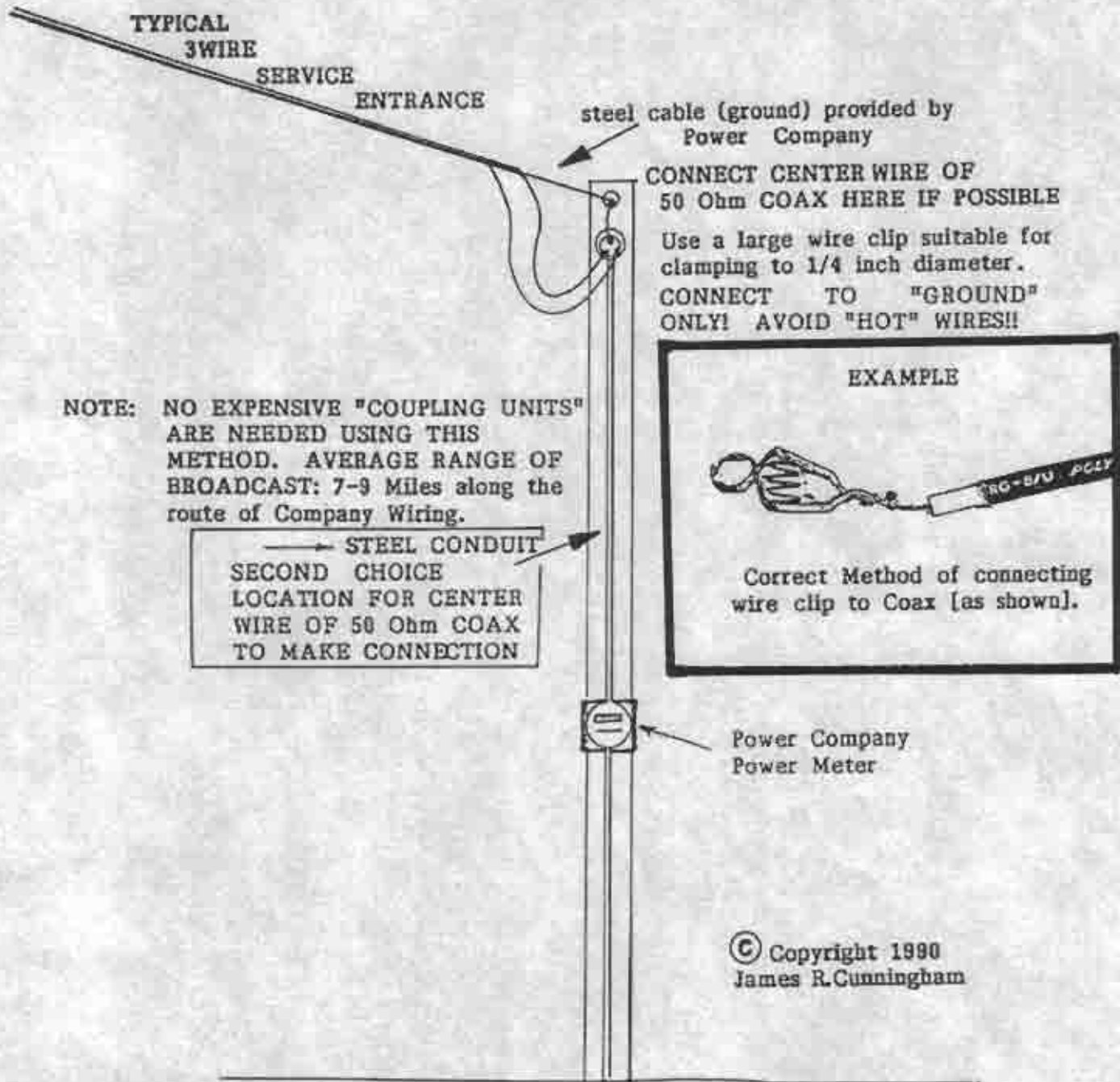

NOTE: NO EXPENSIVE "COUPLING UNITS" ARE NEEDED USING THIS METHOD. AVERAGE RANGE OF BROADCAST: 7-9 Miles along the route of Company Wiring.

STEEL CONDUIT
 SECOND CHOICE
 LOCATION FOR CENTER
 WIRE OF 50 Ohm COAX
 TO MAKE CONNECTION

CONNECT CENTER WIRE OF 50 Ohm COAX HERE IF POSSIBLE
 Use a large wire clip suitable for clamping to 1/4 inch diameter.
 CONNECT TO "GROUND" ONLY! AVOID "HOT" WIRES!!

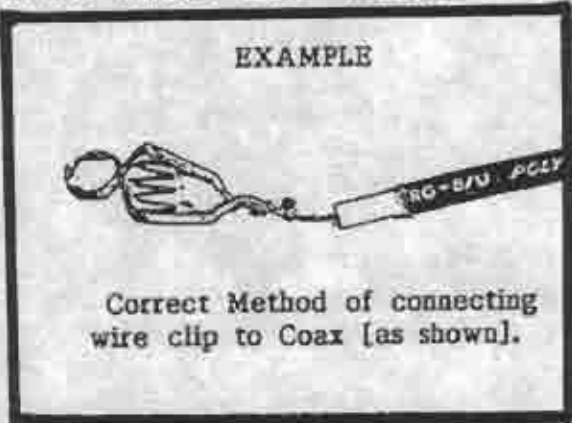

© Copyright 1990
 James R. Cunningham

UNIQUE METHOD OF CARRIER CURRENT CONNECTION

Run output from Carrier Current Transmitter into a 50 Ohm Coax. The center wire at the end of the coax connects to the Power Company Ground Cable as shown, as high up as is practical. The end "shielded" part of the 50 Ohm Coax is not used. The Transmitter has no "ground" except for the neutral wire inside the wall socket where it plugs into the 120 Volt Line Current. The Transmitter will automatically couple enough RADIO ENERGY into the System to make CARRIER CURRENT broadcasting satisfactory in most cases!

NATIONAL EMERGENCY!
POWER LINE BROADCASTING

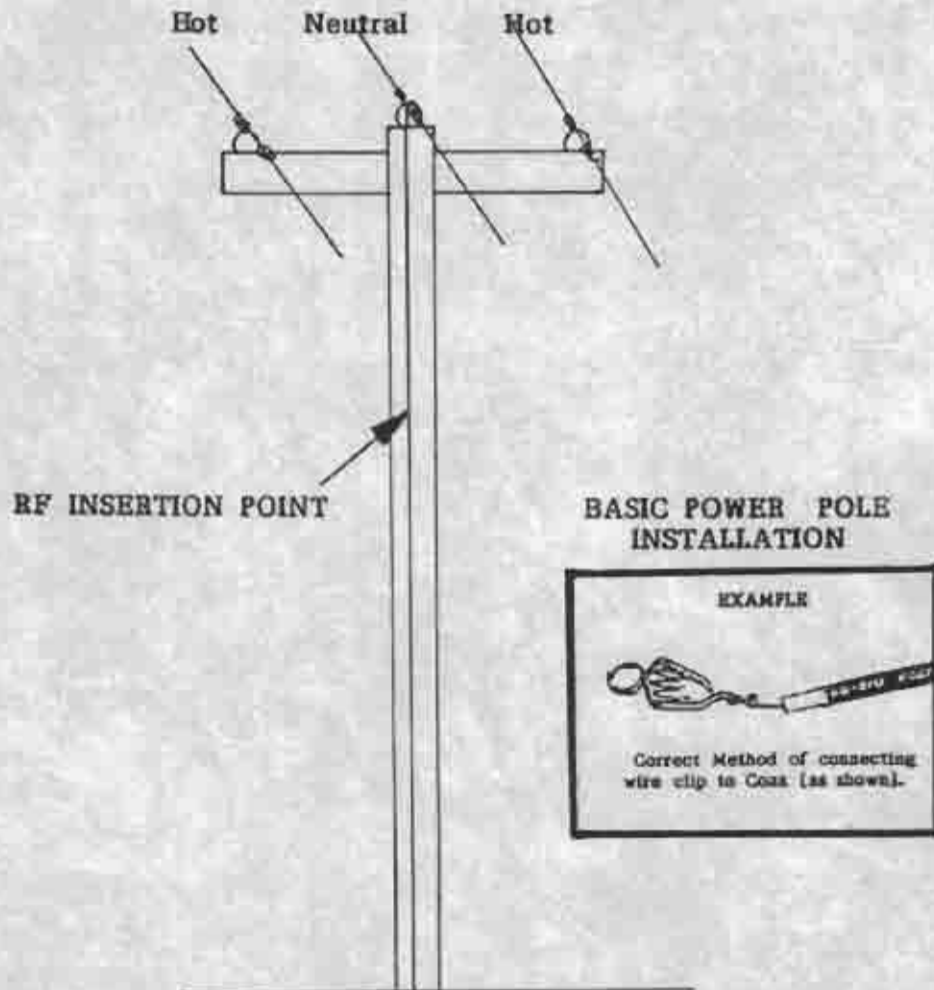

In a typical Power Line installation, you have power poles which appear basically as shown. The HIGHEST wire (usually at center position) is brought down to EARTH GROUND at the bottom of each pole in the system. This NEUTRAL or GROUND wire can be charged with HF (LOWER FREQUENCIES ONLY!!) and will serve as a great CARRIER CURRENT RADIO ANTENNA! The signal will carry for MANY MILES along these wires and other wires tied into the system! BEWARE! IT IS NOT LEGAL TO CUT ANY WIRES, but the Radio Signal will COUPLE into the system simply by using the wire clip method I have developed.

POWER LINE BROADCASTING EXPLAINED

In case of a National Emergency, CARRIER CURRENT BROADCASTING MAY PROVE VERY EFFECTIVE OVER A 5 to 20 mile area. If the Transmitter Power rises above 100 watts, the effective range of coverage will prove competitive with Professional Tower Installations. As much as 1000 watts Radio Frequency energy can be coupled into these Power Lines easily without any tuning devices!! This is possible because the coils inside the transmitter effectively eliminate harmonics when set up properly and the low resistance of the Power Line System helps reduce spurious radiation! The higher power levels must be inserted in a sparsely populated area, otherwise serious interference to TV and Radio reception may result, but lower powers up to 100 watts will cause no problems whatever in most cases. Best results are obtained using frequencies BELOW 3 mHz.

If a factory tuning unit for Carrier Current is available, this may increase coverage by matching the Power Line Impedance more exactly. These Tuning Units are available only at powers below 50 watts, with a few rare exceptions.

Where power is supplied to the transmitter from an EMERGENCY GENERATOR, the Transmitter Case must have a separate ground removed to a distance from the RF Insertion Point. This can be in the same Power Line System, but 100 feet or more removed from the RF INSERTION POINT. A long #18 - #10 copper wire can be attached to a WIRE FENCE or brought along to the next Power Pole in the Power Line System. If there is not sufficient distance between Transmitter Ground and RF Feed Point, you will essentially have A DEAD SHORT!

UNDER THE MOST SEVERE EMERGENCY, you may have to CUT the bare copper wire coming down the pole, using the bottom part of the wire as TRANSMITTER CASE GROUND and the top part of the wire you have cut as ANTENNA. Either use the Coax and wire clip method or use a separate wire antenna tuner.

ANY "TWO" OR "THREE WIRE" POWER COMPANY INSTALLATION WILL BE EFFECTIVE IN CARRIER CURRENT EMERGENCY BROADCASTING, BUT I HAVE FOUND THAT IT IS SAFER AND BETTER TO RUN THE RF INTO THE UPPERMOST "GROUND/NEUTRAL" WIRE THAN TO RISK ELECTROCUTION TRYING TO USE "HOT" WIRES.

TRANSMITTER
TEN WATT SOLID STATE

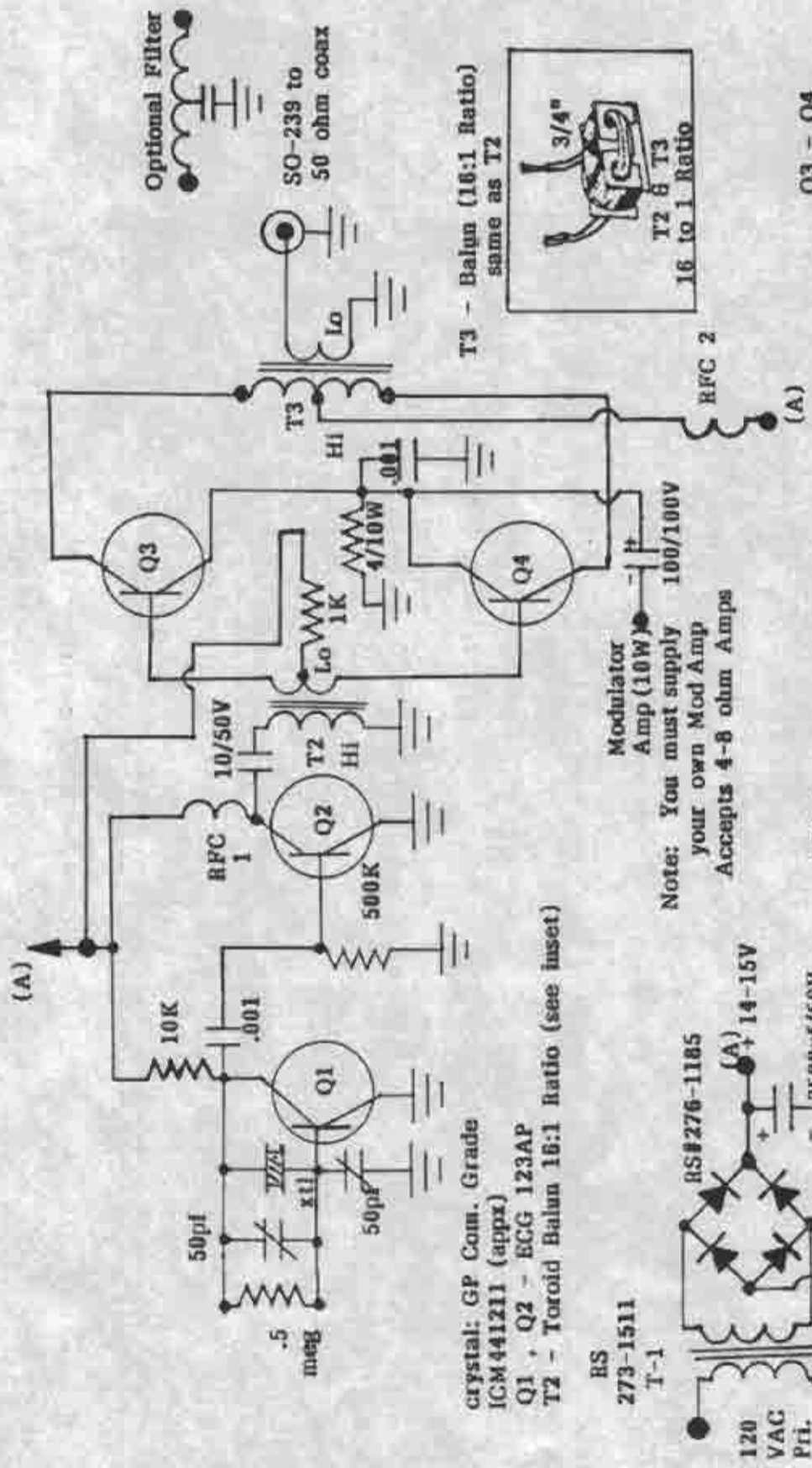

crystal: GP Com. Grade
ICM441211 (appr)
Q1 • Q2 - ECG 123AP
T2 - Toroid Balun 16:1 Ratio (see inset)

RS
273-1511
T-1

RFC-1
80 turns #30 ga. wire
RS # 278-1345 air core

Note: You must supply
your own Mod Amp
Accepts 4-8 ohm Amps

12.6 V-3A
Sec.

RFC 2 - 75 to 100 turns #22 ga.
wire - RS# 278-1345 air core (no ferrites!)

*View output with Oscilloscope into a 50 ohm
Dummy Load Resistor for purity. If there
is a harmonic problem use filter after T3.

Q3 - Q4
OUTPUTS:
2 - C2075's
(ECG 235 eqv)

USE LARGE HEATSINKS!

T3 - Balun (16:1 Ratio)
same as T2



Optional Filter

SO-239 to
50 ohm coax



Figure 1 - Field Intensity Meter, Type WX-2C, Front Cover Open

TECHNICAL SUMMARY

Frequency Range	550 to 1600 kc
Field Intensity Range	10 microvolts per meter to 10 volts per meter
Accuracy of Attenuators	2%
Output Indicator	Panel meter, direct reading, with logarithmic scale graduated 1 to 10 and <u>HAVING NO ZERO MARK</u> (needle is <u>OFF SCALE</u> when meter is not energized). Provision for using recorder. Headphones, high-impedance (not supplied).
Antenna	Shielded, unbalanced loop
Power Supply	Batteries, 5 1/2-volt, (RCA-VS001) 2 67 1/2-volt (RCA-VS016). Provisions for external power supply.
Battery Life	500 indications (approx.)
Electron Tube Complement	4 - RCA-1T4 2 - RCA-1B5

Mechanical Specifications

Overall dimensions, closed: Height 9", width 13", depth 5-3/4".
Weight, including batteries: 12-1/2 pounds.

SOLID STATE FIELD STRENGTH METER

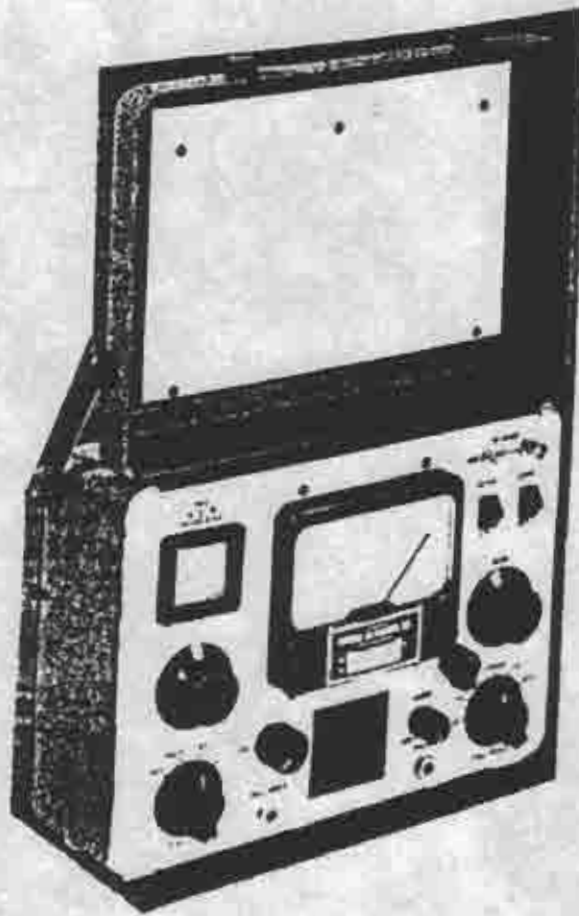

This is an example of a solid state Field Strength Meter for A.M. Broadcast use. The above meter sells for about \$2600.00 new. A used one can be bought usually for around \$1500.00. The tube type meter on the preceding page works just as well and sells for about \$500 in good condition. The batteries for the tube type meter are still available in most of the better electronic supply houses.

With one of these meters, you can read your signal strength at any point, log it, and know that you are operating within the legal limits. If you buy a meter, and doubt its accuracy, just get your Local Radio Engineer to compare readings with his properly calibrated unit and note any differences on a piece of paper and have the Engineer sign the paper showing the amount of error or if your unit is calibrated according to his meter. This will serve as your own "calibration certificate" in case anyone questions the accuracy of your meter.

USING THE FIELD STRENGTH METER



The Author

You may wish to borrow a Field Strength Meter and take the readings yourself. You can do this if your local Radio Engineer or Consultant is very trusting, but usually you will have to pay the man to do the work for you (this is why he is in business).

The Meter is usually hand held or placed on a tripod (like the one used by photographers).

Follow all the instructions and do a good job. You may wish to buy your own meter and check its calibration against your local Engineer's Meter. He may charge you a small fee, but it is to your advantage to know the accuracy of your meter. Get the Engineer to sign a Statement Of Calibration concerning the accuracy of your Meter and keep it in a safe place in case it is ever needed.

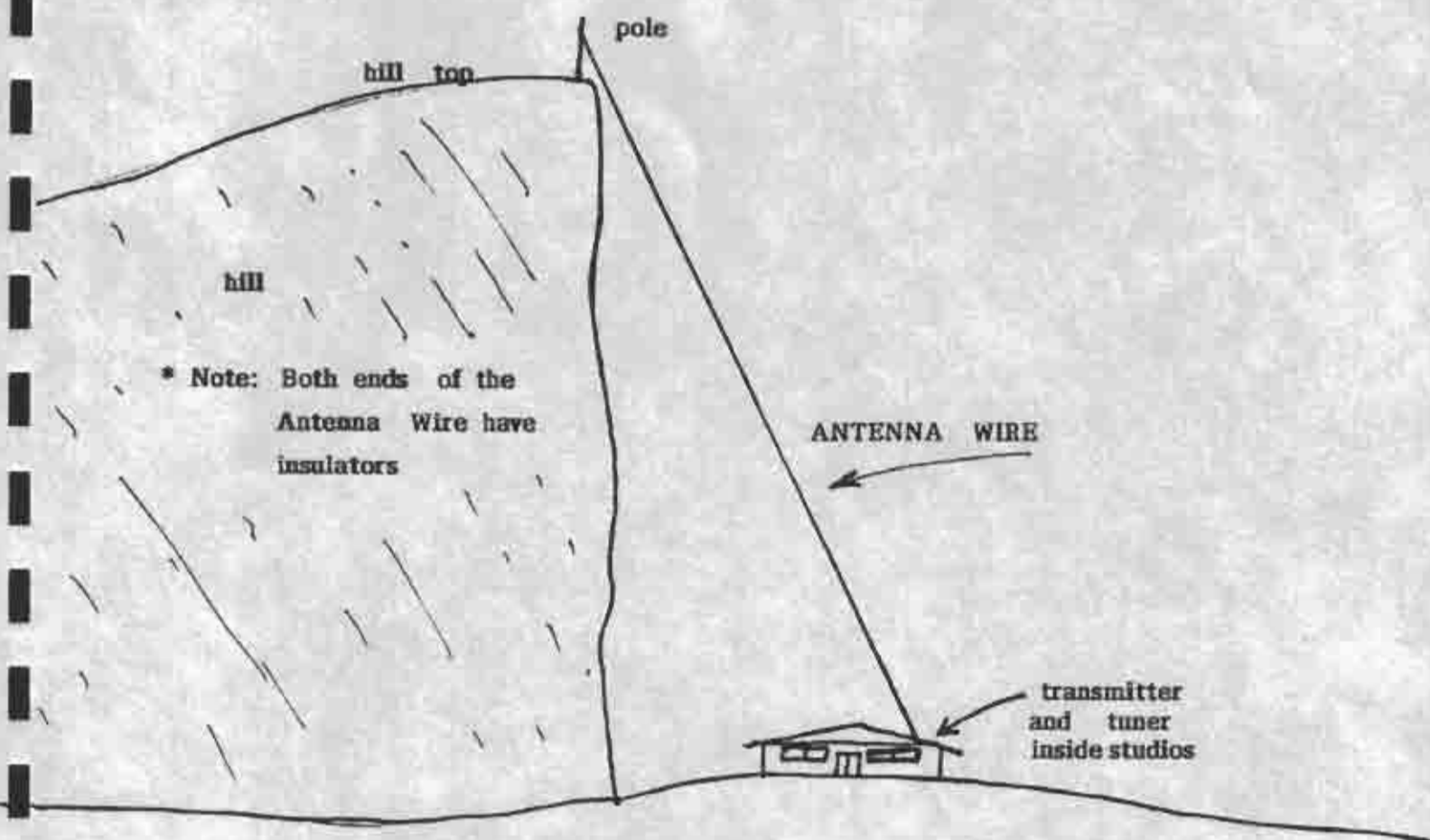

Chapter Three

THE CAMPGROUNDS RADIO SYSTEM

1. Choose a frequency which can not be found on radios in the area. Day or Night!
2. The antenna wire length is 234 divided by frequency in Megahertz.
 - A. [EXAMPLE] 525 kHz: length equals 445 feet! (.525)
3. Use insulators on both ends of the wire antenna.
4. Use as much power from your transmitter as is necessary to cover the Campgrounds, but OUTSIDE THE CAMP, the maximum signal strength must be measured with a FIELD STRENGTH METER and be found LESS THAN 24,000 divided by frequency in KILO-HERTZ. In the example given above, this would be 24,000 divided by 525, which gives 45.7 microvolts per meter!
5. The distance OUTSIDE THE CAMP for these measurements is 30 meters or about 100 feet.
6. You should start out with a power of about ten watts for the average Camp Grounds and be prepared to reduce power if necessary to comply with Field Strength Regulations. Many Camps can be covered with less than 1 Watt power! BEWARE OF POOR ANTENNAS AND TOO MUCH TRANSMITTER POWER! Radio INTERFERENCE and ILLEGAL HARMONICS WILL BE THE RESULT!! Use VERTICAL OR SLOPED WIRES WHENEVER POSSIBLE and avoid SKIP!

ANTENNA EXAMPLES

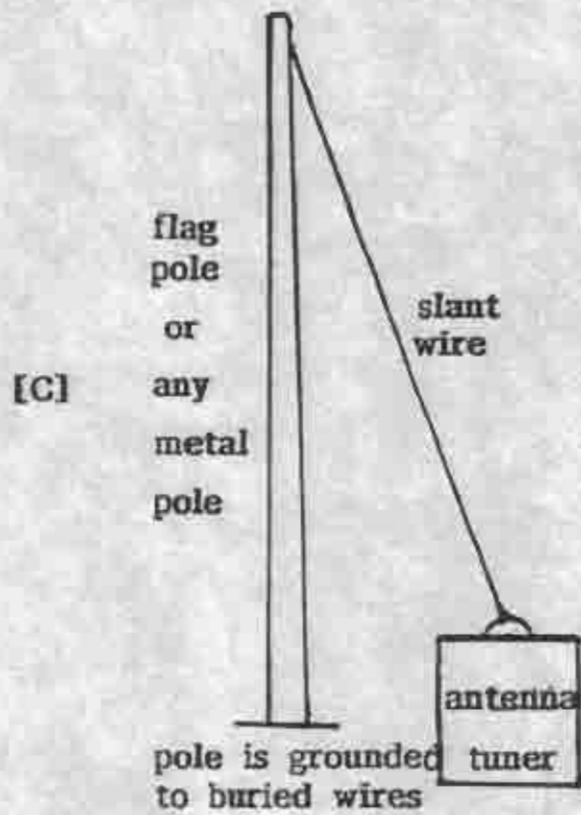
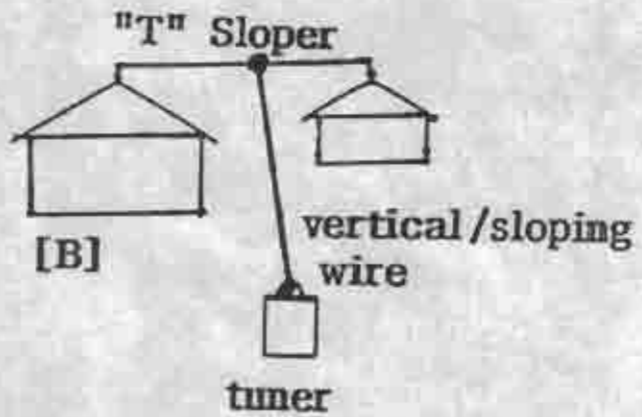
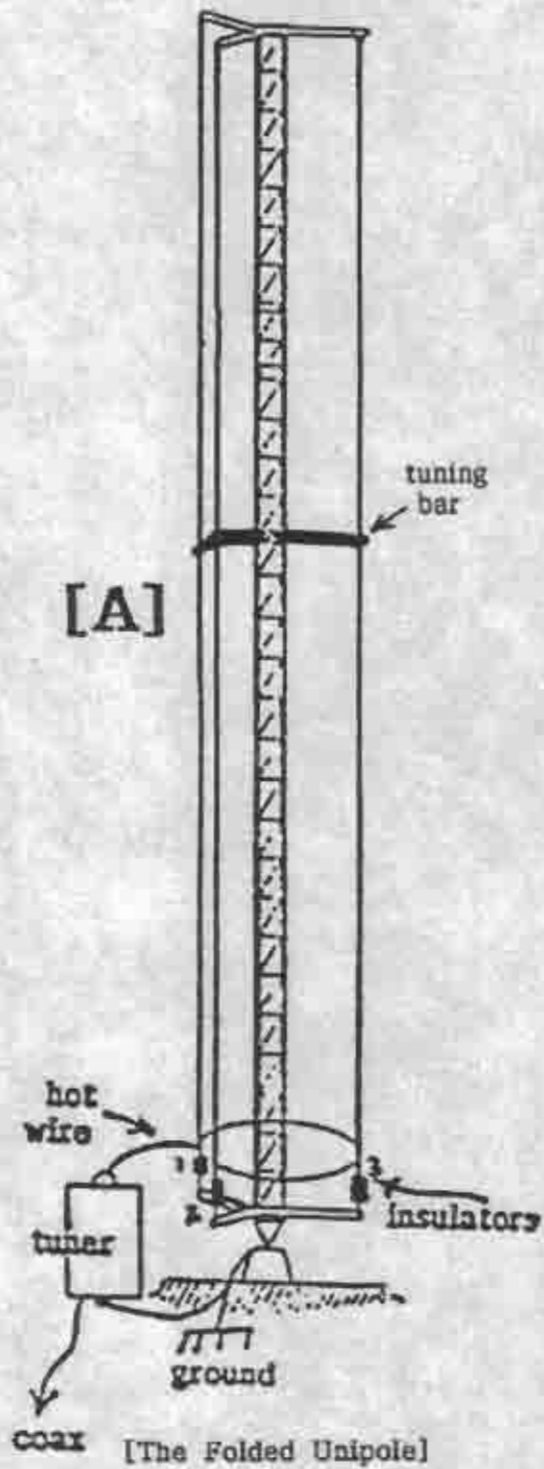

ANTENNAS

Three antennas are illustrated on the preceding page; A, B, and C. These are all essentially vertical antennas, even though "B" uses a "Top Hat" or horizontal member on top. Antenna "A" is probably the best inasmuch as it is easier to tune and gives excellent results. Both "A" and "C" use a metal pole or tower about 40 - 100 feet tall. The effective height of the pole is doubled due to the wire that folds back from bottom to top. Antenna "A" is easier to tune due to the fact that it uses two or three wires going from bottom to top instead of just one. The extra wires have the effect of canceling out reactance and giving a simpler tuning method. Even though it is possible to use "A" and "C" without a tuning box, I never allow this because the added tuning box reduces harmonics and TV interference,

With any of these antennas, the Mission Station will receive sufficient coverage even if the antenna is much shorter than recommended, due to the fact that the tuning box will adjust quite well to shorter antennas. The Antenna Tuner permits maximum efficiency from just about any antenna, plus the added benefit of harmonic reduction.

Antenna "B" is a sloping wire with a "T" on top. This style of antenna gives pretty good coverage and a lower radiation angle [something you need badly]. The same Antenna Tuner will work for any of the antennas shown, except the Tuner will need an extra capacitor for Antenna "C" in order to cancel out the extra reactance caused from only a single sloping wire going up to the top of the pole.

The use of my Antenna Tuning method as presented in this Book will make tuning both easy and correct. If the tuning meter inside the Tuner does not give a strong forward reading (you may also use the C.B. SWR Meter Method) then your Antenna is wrong in some way or you have a large reactance in your antenna which needs to be dealt with. Use a .001 mfd. RF Style Capacitor in series with the Antenna Lead In Wire (where it goes out of the Tuner and into the air) and try tuning again, until the Tuning Meter responds correctly. Never operate your Antenna System unless you are SURE it is tuned properly.

THE FOLDED UNIPOLE (sometimes called monopole)

This antenna has the benefit of assisting in situations where the antenna ground radial system is faulty and where the tower is too short to tune well to the frequency of operation. An added benefit is the fact that this tower is grounded and thereby provides excellent protection against static charges and lightning strikes. Due to the fact that the tower is grounded, it also makes the installation of F.M. Bays much easier since the usual isocouplers are not needed. It is obvious that the savings in construction costs are much lower as well as the maintenance costs.

The tower may be tuned to approximately 50 ohms by using a shorting ring near the top of the tower. This shorts to the tower at the proper point for best tuning and is set up experimentally. A tower man must move the shorting ring up and down while the Engineer measures the tower resistance with a Bridge. Once set up, the 50 ohm feedline may be coupled directly into the tower without the use of a Tuning Unit. A coupling CAPACITOR is needed at the end of the

coax feedline in order to tune out the reactance of the tower. This is usually in the order of .001 mfd./ 10,000 volts at 10 amps. or better. When the tower has been tuned using the capacitor, the full power is applied to the tower and field strength readings are taken along with harmonic measurements. This brings me to tuning method number two.

Method Number Two depends upon an Antenna Tuning Unit at the base of the tower. This consists of a full "T" network adjusted to remove reactance and match the tower resistance. It is not necessary to use the shorting ring, just attach the wires to the top of the tower and connect to the Antenna Tuner as shown in the above illustration. The Tuning Unit Method is greatly preferred because harmonics are reduced to a much safer level and there is no guess-work in tuning the tower.

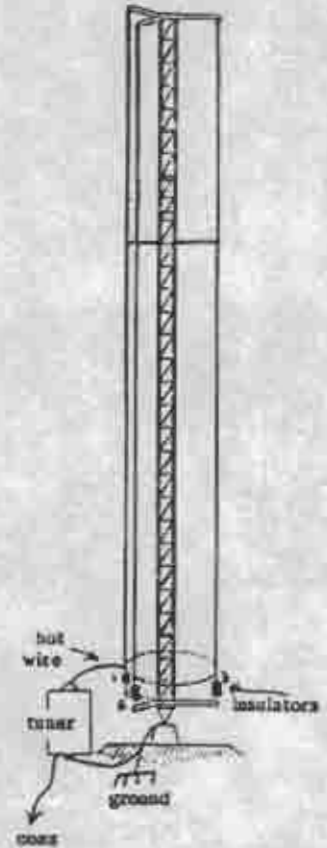

ANTENNA INSTRUCTIONS
LOW COST PRACTICAL, PROVISIONAL

1/4 wave-length copper wire
solid copper - # 22 to #10 gauge
LONG WIRE ANTENNA

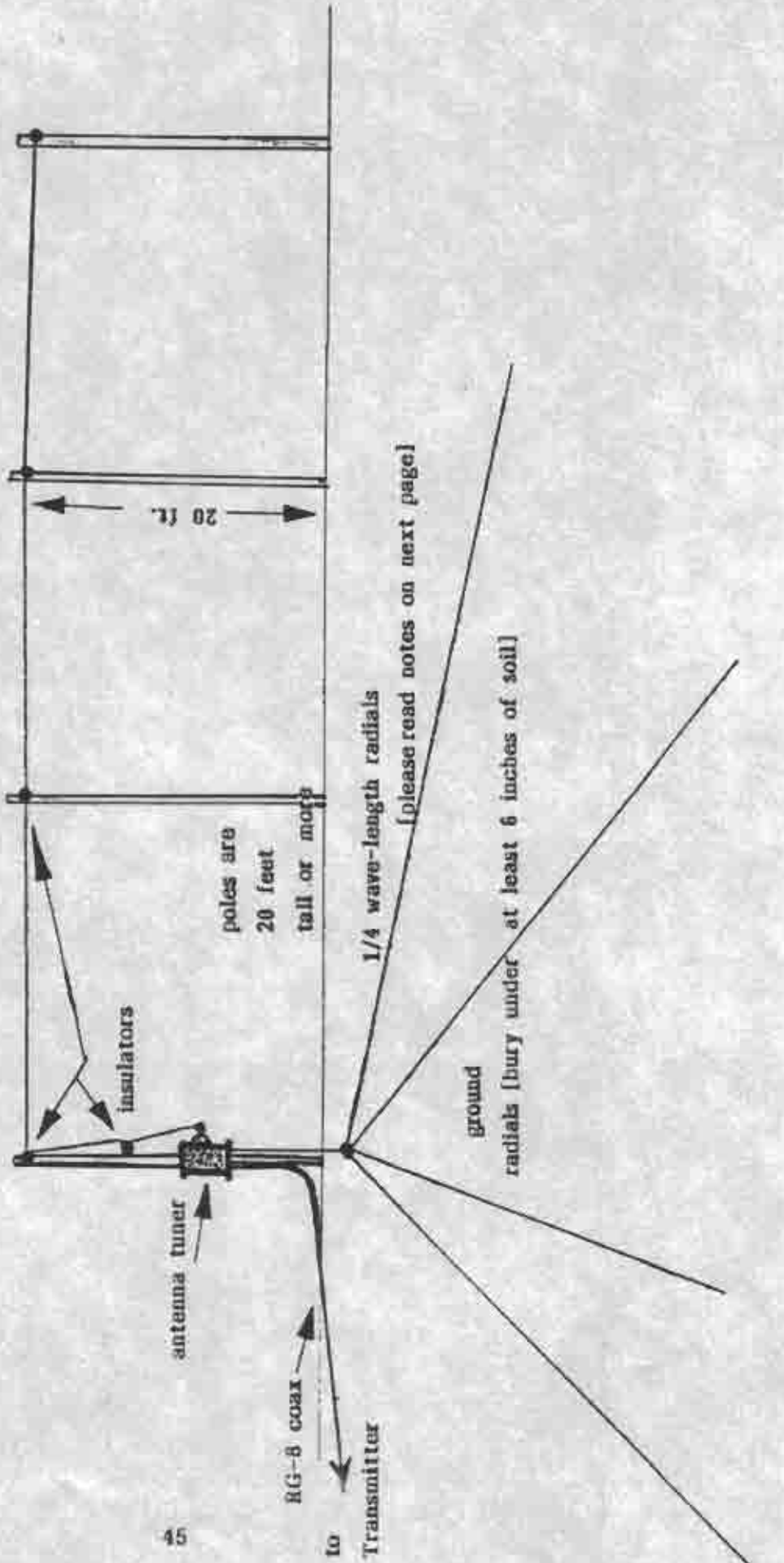

LONG WIRE ANTENNA DESIGN

Shown below is a basic long wire antenna design which is very dependable and easy to construct. This type antenna can be used with all of the reflector/director designs given in this Book and there are less chances of making a mistake using this design, so if you are not a well experienced antenna builder, please use this design rather than the others.

The wire may be any gauge strong enough to support its own weight and carry the antenna currents specified for the transmitter used.

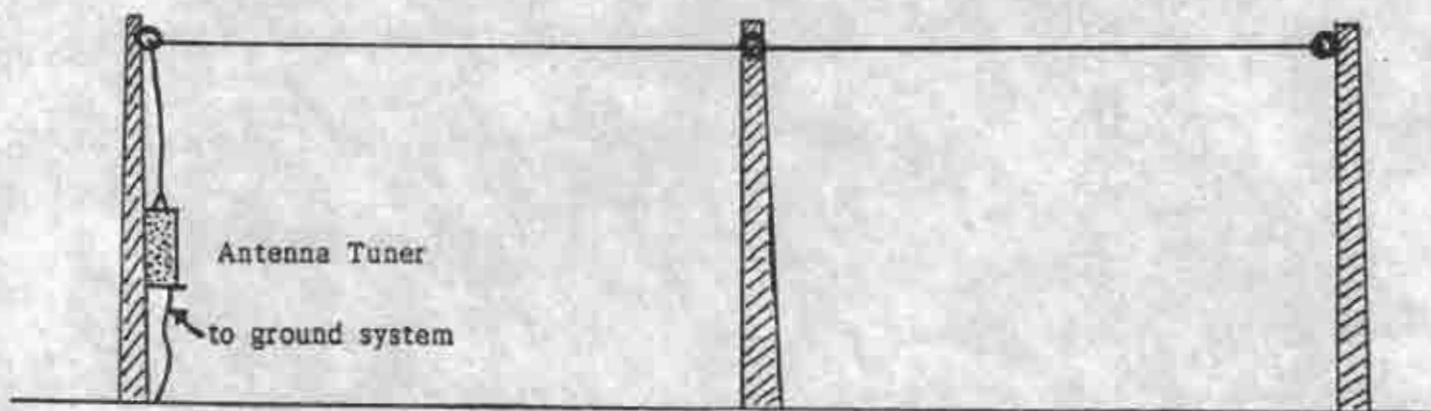

A good ground system is needed beneath this antenna design with radials going out from beneath the tuning box in all directions to a distance of $1/4$ wavelength or greater for best performance. You may use a single $1/4$ wavelength wire going from the antenna tuner out to the left side of the antenna for emergency operation on a temporary basis until a better ground system can be built. Best operation of the antenna requires 120 ground radials of $1/4$ wavelength buried just beneath the soil. This antenna can be any desired length, but $1/4$ or $1/2$ to $5/8$ wavelength is normal. Longer wavelengths provide directional patterns and are not used with Standard Broadcast Frequencies unless quite large portions of land are available. The antenna wire works very well at heights above 50 feet, but great results are obtainable at distances as low as 10 feet above ground level.

You can multiply your antenna's efficiency by using the reflector/director technique described in the Book.

DIPOLE AM WIRE ANTENNA

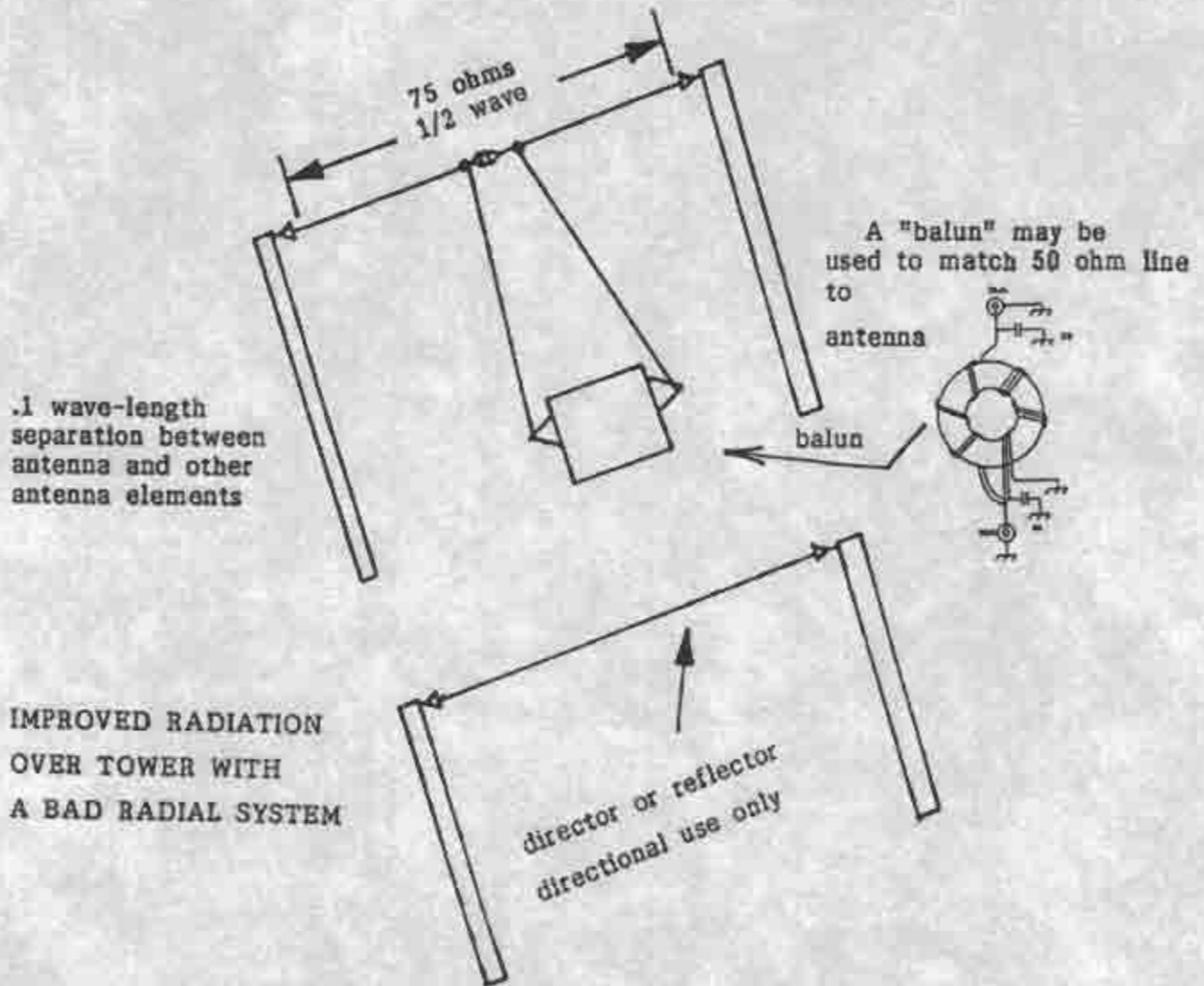

The 1/2 wave-length dipole will work for AM Broadcast frequencies if there is room for placement. The director or reflector is used for directional needs and lowers radiation angle with a 5 - 8 db gain equivalent to 3 times the transmitter power (directional only). Reflectors are 5% longer than the 1/2 wave antenna and directors are 4 - 5% shorter. These work best with a good ground system, but function better than a tower when there is a poor ground situation. The line tuner transforms unbalanced coax to a balanced antenna. The feed lines are short and are considered a part of the entire antenna length in the above diagram. A longer balanced feedline may be used if desired. The poles are 30 to 50 feet in height. Higher poles are nearly impossible to find and up construction costs greatly. If the Transmitter will tune to 75 ohm coax, then the balun is not needed, just connect directly!

TECHNICAL SERVICES

— BROADCAST

— RADIO

— TV

James R. Cunningham, Bdcst. Eng. [405-265-4496]

P.O. Box 8, Stonewall, OK 74871

THE "GALCOM" WIRE ANTENNA

The "GALCOM" wire antenna (placed on poles) is a modification of the DDRR vertically polarized antenna FEATURED IN "The Radio Amateur's Handbook" of 1965. It is illustrated on PAGE 372. That drawing is copied below:

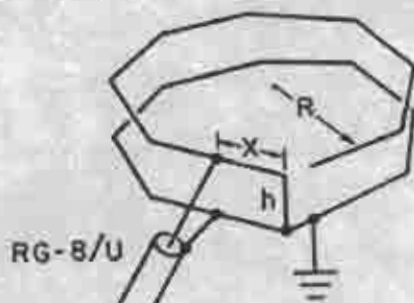

(B) The unusual DDRR vertically-polarized antenna. Length around top (open) wire or bottom (closed) wire, in feet, = $252/f$ (Mc.) (E.g., 64.7 feet for 3.9 Mc.). Height $h = 8.5/f$ (Mc.) (E.g., 2.2 feet at 3.9 Mc.) The feedpoint distance, x , is given approximately by $x = 28/f$ (Mc.). (E.g., 7.2 feet at 3.9 Mc.)

The DDRR Antenna

A new (and controversial) vertically-polarized antenna is the DDRR (directional-discontinuity ring radiator) shown in Fig. 14-27B. (See *Electronics*, January, 1963).

If an excellent ground is available, the bottom wire would not be required, otherwise it should be laid on the ground or the roof or whatever flat plane the DDRR is placed over. The antenna shown is the version tried by WØMOX, which is simpler to construct than the original circular configuration. This is an antenna that merits further investigation by experimentally-inclined amateurs.

The Antenna is $1/4$ wavelength long, placed in a circular or rectangular fashion, measures 36.8 ohms, Zero Reactance, and is tuned with a Standard "T" Network Tuner. Its **VERTICAL RADIATION ANGLE IS 36 Degrees**, with confirmed **vertical polarization**. The Antenna's **SIGNAL STRENGTH IS 28 MV/M per Amp.** which corresponds to **145 MV/M per 1000 Watts Input Power.**

The 36.8 Watts from James R. Cunningham's Tube Type Transmitter provides an antenna current of 1 Amp. into the Antenna shown above. The expected radiation is 28 MV/M at 1 mile distance from the Antenna Site.

ANTENNA RADIATION MAY BE INCREASED BY ADDING 120 - $1/4$ wavelength GROUND RADIALS below the center of the antenna, extending towards all points of the Compass. Theoretical Signal strength **INCREASES TO: 35.53 MV/M per Antenna Amp.** or **186.2 MV/M at 1 mile with 1000 watts Antenna Input** if the superior ground system is used.

JAMES R. CUNNINGHAM

THE DDRR "GALCOM"

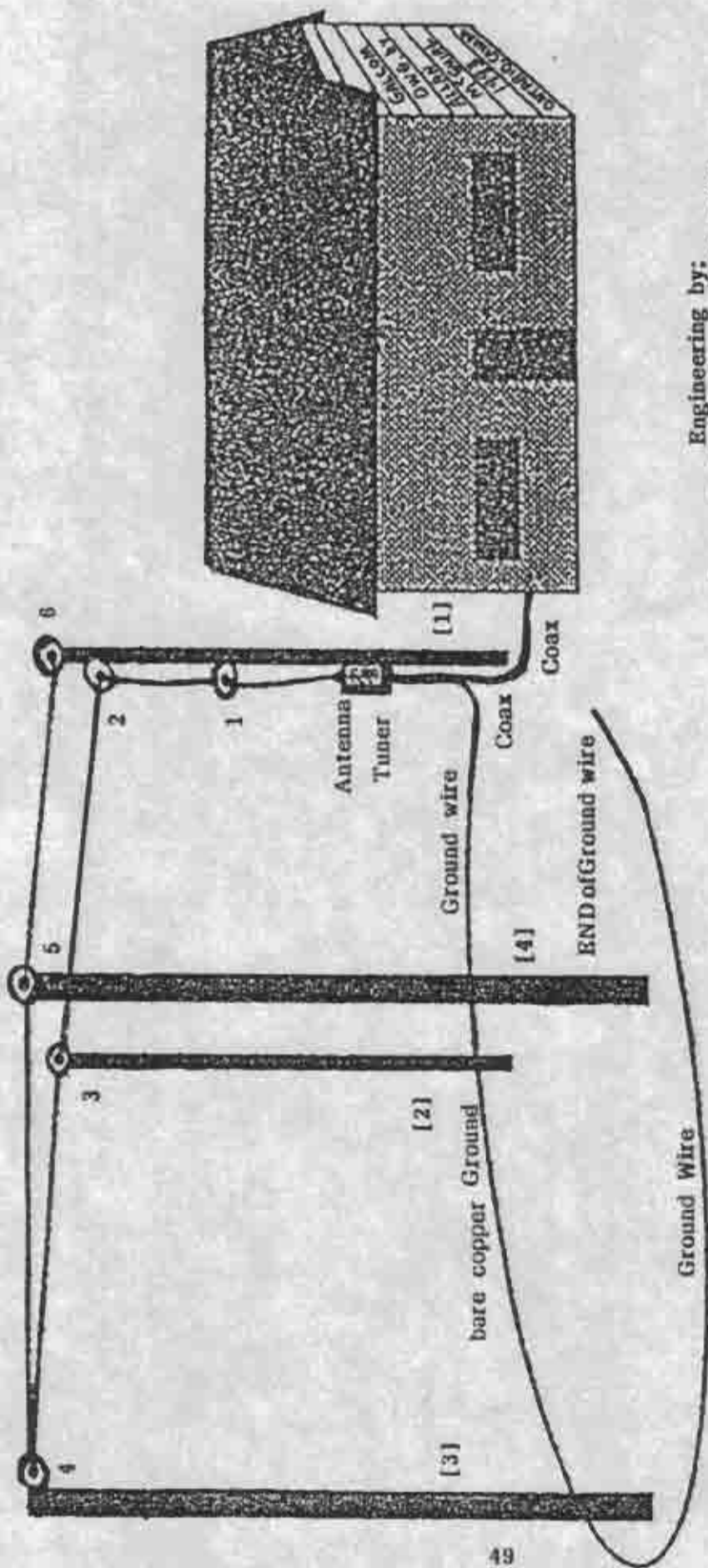

Engineering by:
James R. Cunningham - USA 1993

THE DDRR ANTENNA

1. Use 4 poles (wood or metal) 10 feet high or no more than 20 feet high for the DDRR "Effect"
2. Use 6 INSULATORS of the Ceramic "Screw In" Type or "Dog Bone" Type
3. Use 1/4 or 1/2 Wavelength #18-#6 Gage bare copper wire for "GROUND" [Wire ends 1 ft. from #1 Pole!]
4. Use 1/4 or 1/2 Wavelength #18-#6 Gage INSULATED WIRE for TOP ANTENNA WIRE
5. TUNE WITH ANTENNA TUNER FOR MAXIMUM RADIATION

FACTS ABOUT GROUNDING

A good ground system is necessary in order to have a good signal on A.M. Broadcast Frequencies. In locales where there is plenty of rainfall and enough water under the earth, the number of radial wires buried beneath the earth is less critical to obtaining a good signal.

The minimum number of wires buried under the earth should be 15. Up to 120 $1/4$ wavelength should be used where practical, but in emergency situations, good Broadcasting is possible with only a single radial wire laying on top of the earth. The addition of extra wires insures a better signal, especially when the earth is dry.

DEPTH OF BURIAL

The ground wires will work very well if they are laying on top of the earth, but to insure against theft, damage to the wires, and better contact with the moisture under the earth, they should be buried. The maximum burial depth is about 16 inches, but only 6 inches is sufficient and quite normal. Too much burial depth is not beneficial to the operation of the antenna system.

EMERGENCY OPERATION

Locate a place to put up $1/4$ wave-length of wire on poles or between buildings. Use either bare or coated wire from #22 - #10 gauge diameter. Run the wire between insulators and keep away from metal roofs or other large flat metal objects. Emergency antennas can be put between trees and held with strings, ropes and wires, but care should be taken to keep the "Hot Wire Antenna" away from objects at least 4 to 6 inches. Plastic insulators can be made as shown if Commercial Types can not be found.

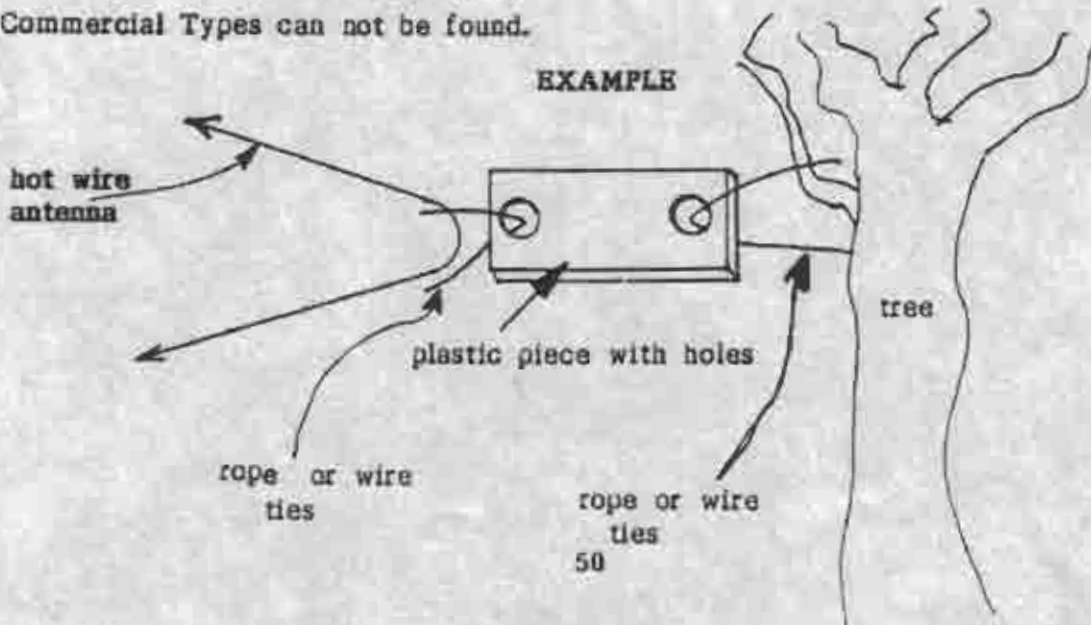

EMERGENCY OPERATION continued

The long wire antenna can be put up in a straight line, but to conserve space requirements, it is possible to weave the wire back and forth between trees, posts or buildings. It should have a separation of at least 35 feet between turns in the wire in order to prevent too much reactance in the antenna wire. The wiring diagram shown below has been tested at up to 500 watts of power without any harmonics or tuning problems. The ground system worked very well because it was connected to wire fence that went around the property. This will be discussed in a moment.

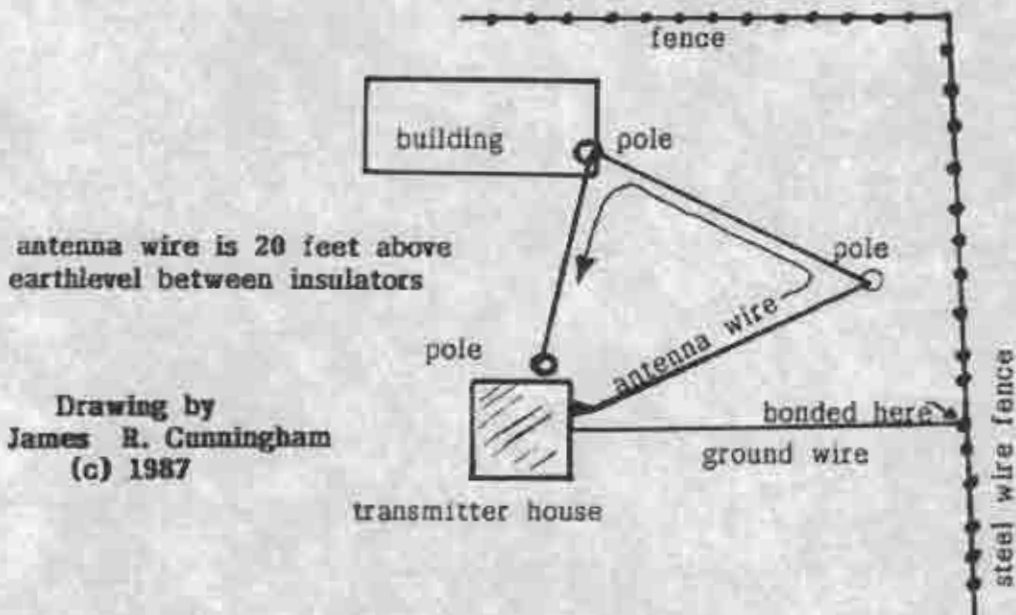

BONDING THE GROUND WIRES

The copper ground wire shown above was connected to the steel wire fence as follows: 1. All rust and dirt was removed from the point of connection with a file or knife. The copper wire was wrapped at least 6 turns about the steel fence wire. 2. The copper was bonded to the steel fence wire using a low temperature torch and solder. Use silver solder for longer life, but regular lead solder will work well. Only a single grounding wire was needed since the steel fence was quite long. Where copper wires are connected together, always wrap 6 turns and solder using the torch. If this is not done, the antenna will de-tune itself in as little as 4 or 5 days and your area of signal coverage will be lost.

THE IMPORTANCE OF GROUNDING FOR AM RADIO

In the case of AM Radio, the "antenna" consists of TWO PARTS. (1) The TOWER or ANTENNA WIRE ELEMENT SUSPENDED ON POLES AND INSULATORS and (2) THE EARTH ITSELF.

In order to make the earth act as the second half of an AM ANTENNA, you must have a number of ground wires going in all directions. It has been found by actual experience that in very dry areas, 120 wires at least 1/4 wavelength long are needed or the signal will not leave the tower or wire for its desired receiving points.

GROUND CONDUCTIVITY describes the ability of the earth to act as the other half of your antenna. In rare cases, where there is much surface water, or water less than 20 feet below the surface, there is no need for many GROUND RADIALS (as the ground wires are called). The earth itself carries the signal out in what is called A GROUND WAVE. This ground wave is very helpful in order to reduce "fading" and weak signals. The ground wave can reach out about 100 miles, and in some cases 150 miles from the transmitter site.

IT IS IMPORTANT TO SET UP A "GROUND WAVE" from an AM Station. One can not depend completely upon one or two ground wires, even where the earth is full of ground water because such a few number of wires may develop problems, or for some reason fail to operate correctly, so A LARGE NUMBER OF GROUND RADIALS IS RECOMMENDED for AM Stations - AS MANY AS POSSIBLE - UP TO 120 QUARTER WAVELENGTH RADIALS going out to all points of the compass!

ONE OF THE ANTENNAS WE USE IN OUR LOW POWER AM INSTALLATIONS IS THE "DDRR" TYPE used by GALCOM and developed by James E. Cunningham especially for this purpose. This Antenna uses only 1 GROUND RADIAL under NORMAL CONDITIONS, BUT IN SOME CASES IT MAY REQUIRE MANY, MANY MORE RADIALS - especially where the earth is DRY, SANDY OR ROCKY!! If you have a question about the effectiveness of the SIGNAL, contact us for consultations before investing in a system or acquiring the station LICENSE!

SHORT WAVE RADIO

The importance of GROUNDING decreases for short wave, especially at frequencies above 3-5 MHZ. Short wave at these lower frequencies also needs good grounding, but it is not nearly as critical as the AM Frequencies below 1 MHZ! Many AM Broadcasters chose a LOWER FREQUENCY under the belief that it will reach out farther, ONLY TO SUFFER FAILURE BECAUSE THEY CAN NOT AFFORD TREMENDOUS EXPENSES ASSOCIATED WITH BUILDING AN AM ANTENNA SYSTEM BELOW 1 MHZ. If you select a frequency BELOW 1 MHZ, BEWARE! YOUR SIGNAL WILL NOT DO WELL UNLESS YOU SPEND OVER A THOUSAND DOLLARS FOR A SIMPLE SYSTEM AND MANY THOUSANDS OF DOLLARS FOR THE BEST!

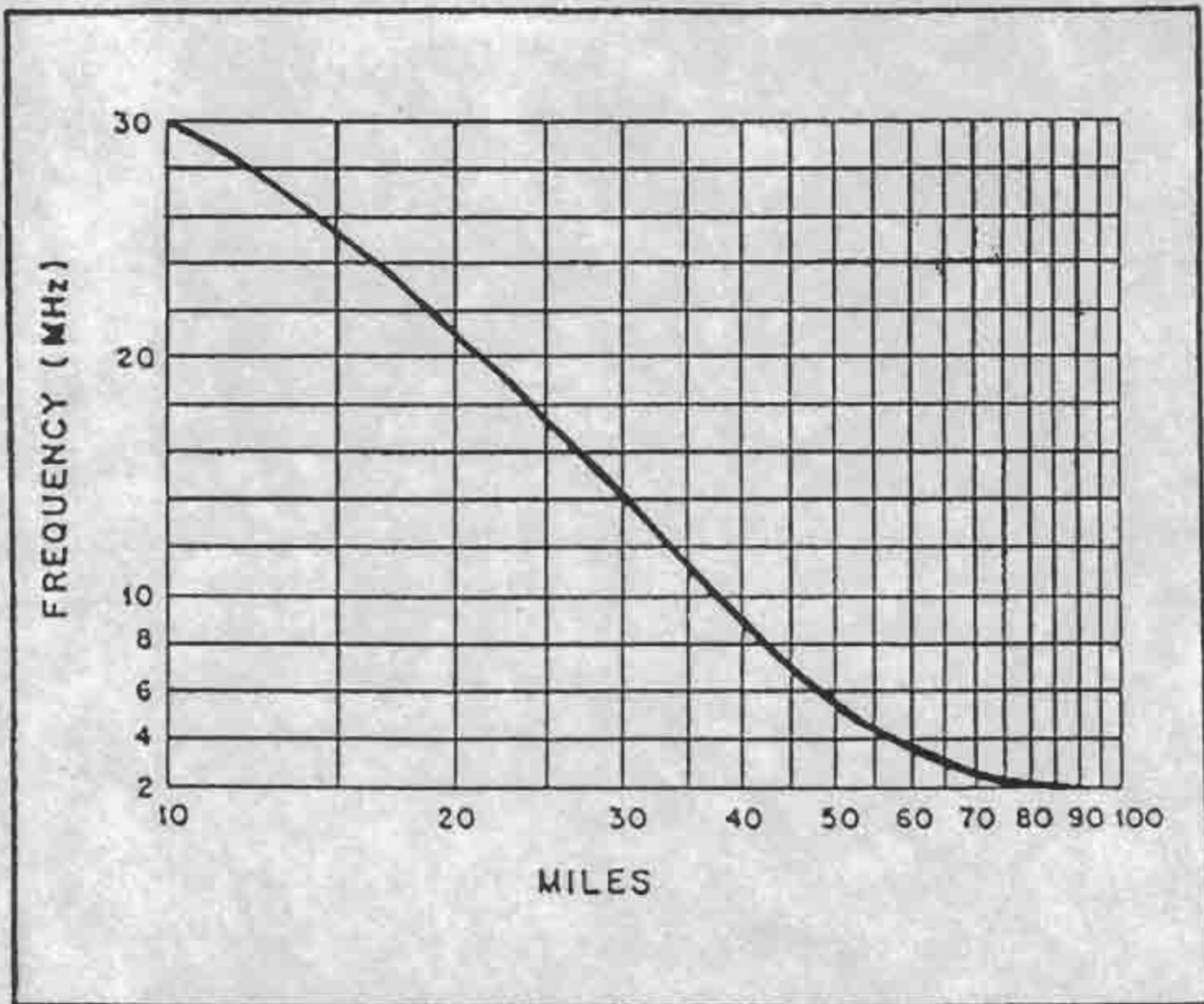

Typical hf ground-wave range as a function of frequency

HF (SHORT WAVE) Vs. STANDARD BDCST.

As you can see by studying the chart, as the frequency INCREASES, the coverage by way of Ground Wave DECREASES. You may also be able to tell that BELOW 2 MHz, a good GROUND WAVE is capable of up to 150 miles of coverage, DEPENDING ON THE POWER OF THE STATION. GROUND WAVE can be depended upon in areas WHERE THERE IS MUCH WATER CLOSE TO THE SURFACE (where wells less than 20 feet deep find WATER)! In such cases, AM RADIO SHOULD BE USED WHERE POSSIBLE FOR MAXIMUM COVERAGE!!

The insulated Guy Wires increase the overall length of the antenna system and provide better coverage.

40ft mast

guy wires attach to metal mast

Legal for Amateur Bands in the USA!

HOT WIRE ON TOP OF TUNER CONNECTS TO METAL POLE AT THE BASE OF THE MAST

Guys are insulated at bottoms

insulators

insulator

insulator

PVC PIPE INSULATOR (prevent mast from shorting to roof)

tuner box

GROUND WIRE

Warning! Use of this antenna may not be legal in the USA - Check with FCC!

GROUND STAKE

GROUND WIRES UNDER SOIL OR ON TOP

Drawing by James R. Cunningham © 1989

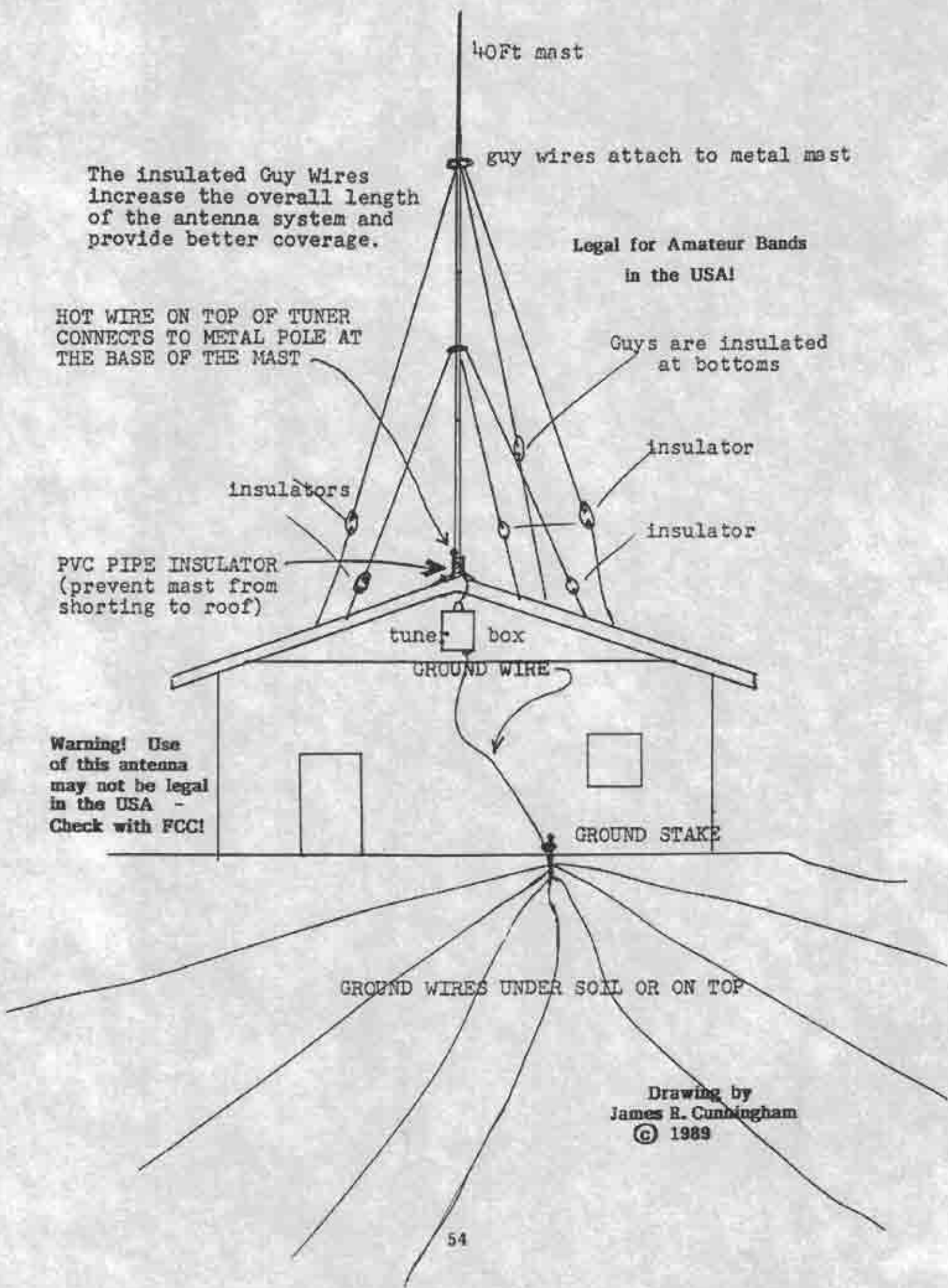

On the preceding page, you see the illustration of a 40 foot mast (the kind used with TV antennas) on a roof-top. The mast is used here for Broadcasting at an A.M. Frequency in the Broadcast or Shortwave Band. The electrical length of the 40 foot "tower" is increased by using insulators on the guy wires at the point where they come down and touch the roof. The bottoms of the guy wires are insulated from the roof and the base of the antenna mast is also insulated from the roof using a plastic [PVC] pipe type insulator made to match the bottom of the mounting bracket (not shown in the illustration). The antenna mast [40 feet] plus the guy wires together make up about 90 feet for the electrical length of the entire radiating element. This antenna length is most effective at the following frequencies: (1) 2.6 MHz & (2) 5.2 - 6 MHz. in the shortwave bands. The antenna will also work at lower frequencies into the Standard Broadcast A.M. Band but will be much less effective! In many Nations, such an antenna is permissible for Broadcasters just starting up in Broadcasting. If there is a need to use this system for frequencies from 1 - 1.6 MHz., you may add another wire or two to the guy wires and extend them out away from the building and tie the ends onto insulators. This increases the electrical length of the antenna and will increase radiation up to the desired level. You will find the proper length of your antenna by dividing 234 by your frequency in megahertz! This will give you the right length for a 1/4 wavelength antenna wire or tower. Although 1/2 wavelength antennas give better radiation results, I am not covering them in this Book because they tend to be too expensive to use at the lower Broadcast frequencies.

Long wire antennas may be put up in small areas by weaving the wires back and forth between poles, roof-tops or trees keeping them away from metal objects. Use insulators at the tie points of all wires and keep the wire away from objects where possible. These wire antennas will work very well if they are placed properly. In cramped quarters, you may need to experiment with various configurations before you find the best possible combination to reach your area of coverage.

I will now show you how to increase your coverage using A DIRECTIONAL WIRE ANTENNA which will give you the equivalent of 6 TIMES YOUR TRANSMITTER POWER without costing you 1 cent on your electric bill!

SUPER DIRECTIONAL WIRE ANTENNA

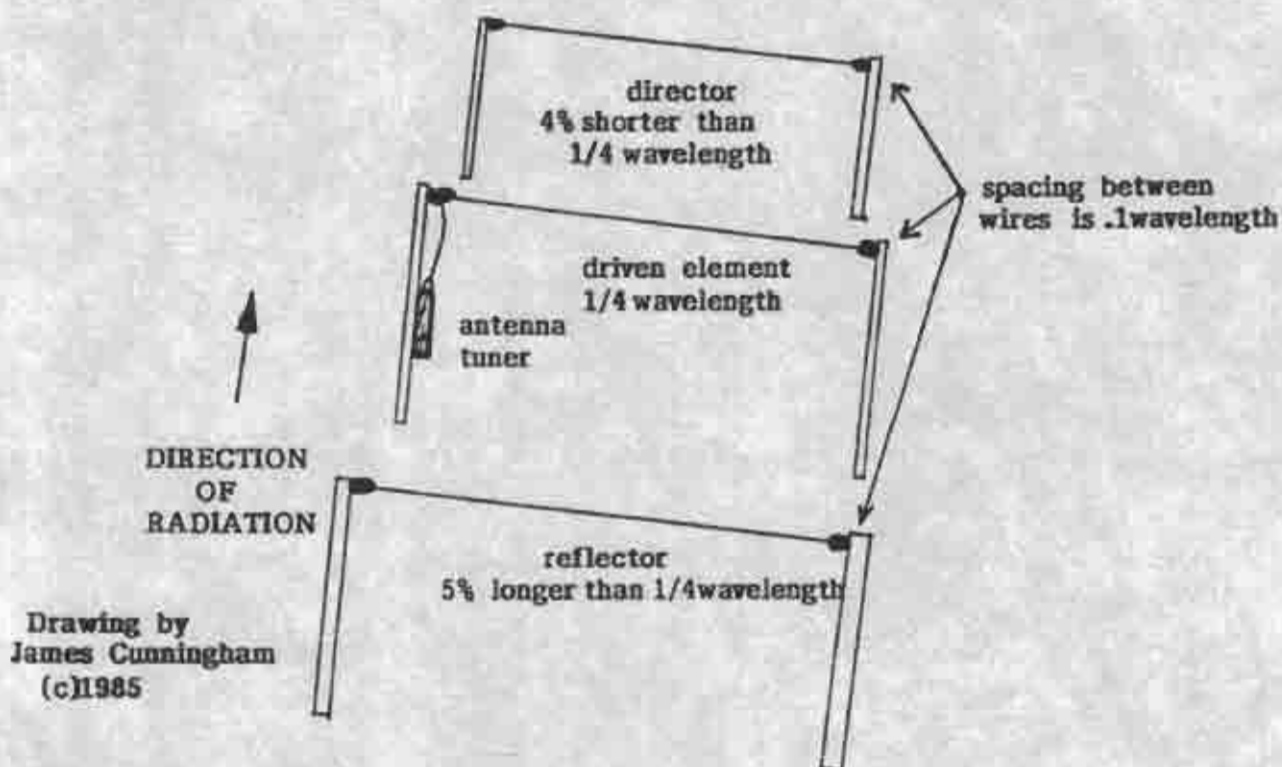

THIS ANTENNA INCREASES YOUR
RADIATION TO EQUAL
SIX TIMES TRANSMIT POWER!

The wires are number ten or larger with spacing between the elements at $.1$ wavelength. The poles are between 15 and 50 feet high, the higher the better. The "director" and "reflector" are insulated from the poles with the same kind of insulators used on the driven element. The length of wires and spacing between elements will vary with every frequency, so be sure to figure the lengths for your individual frequency - some one else's antenna will not work for you unless the frequency is the same! Use a good ground wire system underneath the driven element because this antenna will not work without good grounding. Your coverage will improve in the direction of the radiation equal to 6 times the transmitter power over only a single $1/4$ wave wire.

LONG WIRE WONDERS

Drawing by
JR Cunningham
(c) 1985

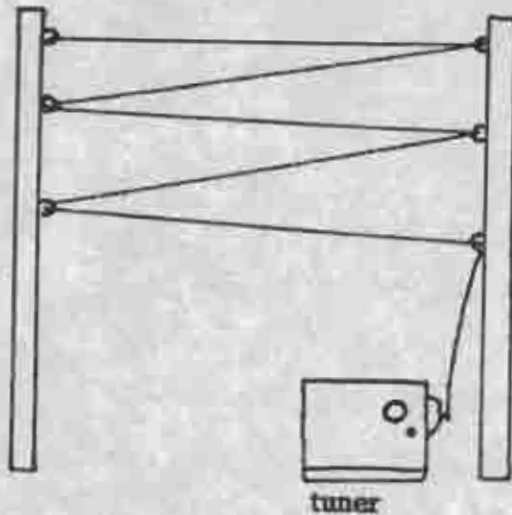

Better results than a
tower
with a poor ground
system

Try This!

The long wire antenna above can be made $1/4$ wave-length, $1/2$ or longer with amazing results! When cramped for space, and the tower won't put out a decent signal, this will improve the coverage. The poles can be spaced apart as needed for the frequency and the heavy copper wire spaced from top to bottom between insulators. I have used this method as close as 20 feet from the earth with acceptable results. There can be as many poles as needed about the place to get the wire antenna to fit on the property. The above style is easier to predict results, but compared to the straight dipole, this is better than you could expect. This antenna "wonder" requires a reasonable attempt at a ground system as no antenna will work well at these frequencies without good grounding.

Speaking of grounding, I have discovered that with the usual ground screen in place, if there is insufficient room for radials, a wire mesh fence can be erected around the property and tied into the radials. The wire mesh fence should be grounded every ten feet with a ground stake, and as often as possible tied into the radials coming from the center ground screen.

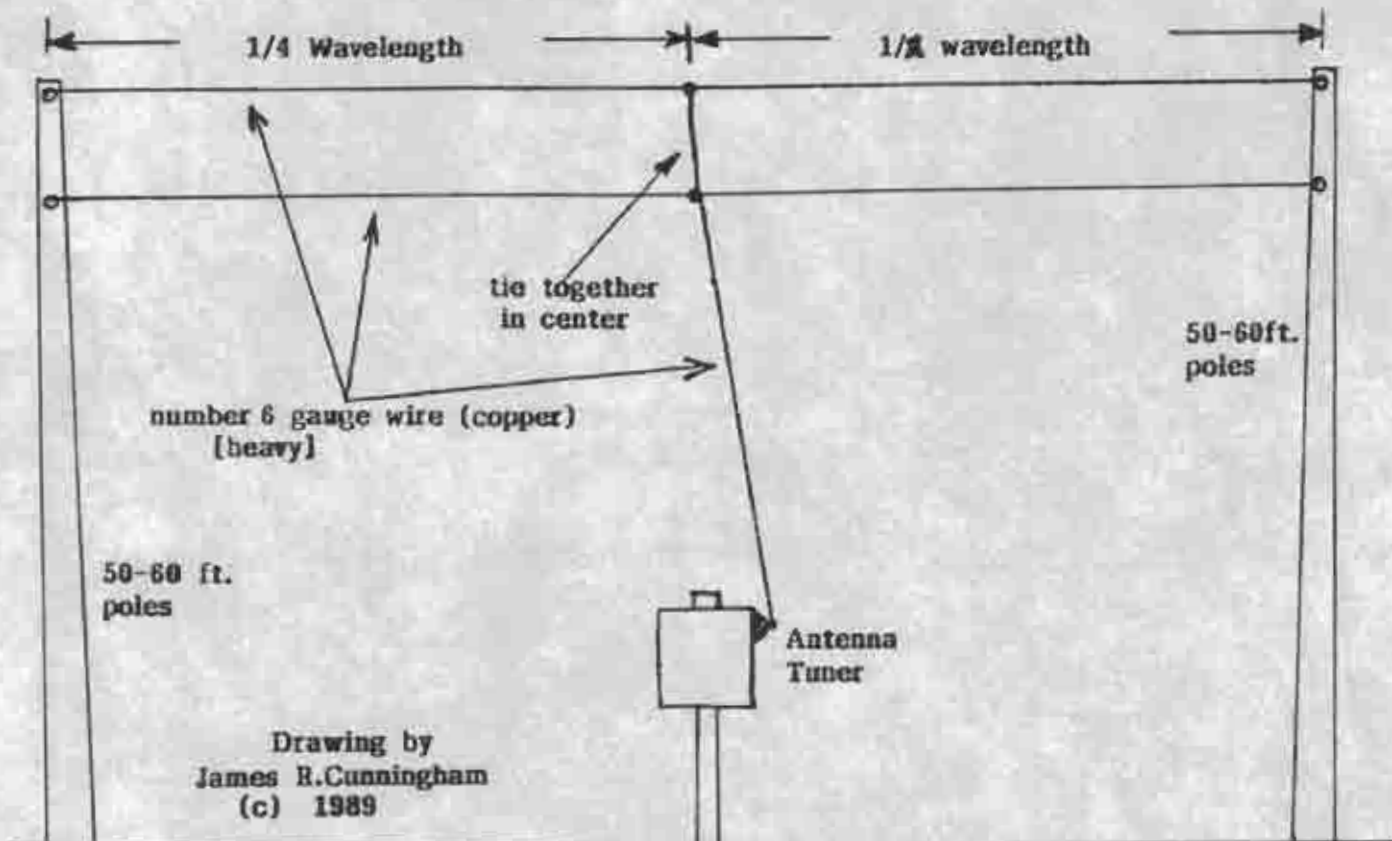

A PERMANENT TYPE VERY EFFICIENT LONG WIRE ANTENNA

The antenna diagram above is for a permanent long wire installation that will not be changed or removed for many years. The poles are 50 to 60 feet tall and are the type used by the Electric Power Company. The wire and insulators are also the same as used by the light and power company. The spacing between the top and bottom wire is not critical, but usually is about 18 to 36 inches.

The antenna is efficient if many ground radials are used beneath the wires. These are number 10 wires and are 1/4 wavelength long. The wires on top of the poles are #4, #6, or #8 wires. The best type are the heavy wires as used by the Electric Light and Power Company. This antenna will withstand high winds and will be very effective if used with many ground radials beneath it. Bury all ground radials with at least 6 inches of earth.

**EXAMPLES OF WIRE ANTENNAS
and ASSOCIATED RADIATION PATTERNS**

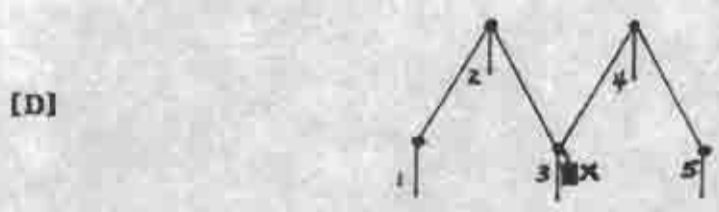

ALL WIRES
ARE INSULATED
FROM POLES AND
TUNED AT [X].

EXAMPLES

A. Example [A] uses a wire stretched between poles (1) and (2). Point (X) is the tuning device. A Standard 1/4 wavelength wire will tend to radiate in a direction AWAY FROM THE TUNING DEVICE AND TOWARD TOP AND BOTTOM OF THE DRAWING.

B. This antenna is stretched between (3) poles and tuned at point (X). This wire tends to send out its signal equally well IN ALL DIRECTIONS.

C. This wire antenna is made CIRCULAR using 9 poles and tuned at point (X). Its radiation pattern is also IN ALL DIRECTIONS (CIRCULAR).

D. Using a 1/4 wavelength wire on each side of point (X), this "M" shaped antenna using 5 poles also radiates very well in ALL DIRECTIONS.

THE ANTENNA TUNING UNIT

Since this Book is being read in many Foreign Countries, I am including the Illustration of the Antenna System used for Low Power Broadcasting in those Nations. In many Nations, a 50 watt Transmitter and a long wire Antenna is all that is needed to get started in Broadcasting. The use of this antenna system lays a very strong signal over about 70 square miles and a "readable" signal over several hundred more square miles. This can be sufficient to cover a Major Money Market in many Third World Nations due to the population concentration within the inner cities.



The 50W Tuner

Shown is the Unit I provide for my 50 watt Transmitter when used with the Long Wire Antenna or a Tower. This Unit tunes Antennas up to and including 250 watts drive power. The top insulator connects to the Antenna Lead In and the bottom of the Box connects to the Ground System. The Unit is tuned and padlocked to prevent tampering. It mounts to the side of a building or to a pole. I will show on the next page, the schematic for the inside of the Unit.

THE TUNING UNIT SCHEMATIC

The Tuning Unit uses a full "T" Network for impedance matching and harmonic reduction. Employed within the case is a special "Tuning Meter" so that any non-skilled person may accurately tune the meter for a near-perfect match to any 1/4 or 1/2 wavelength Antenna.

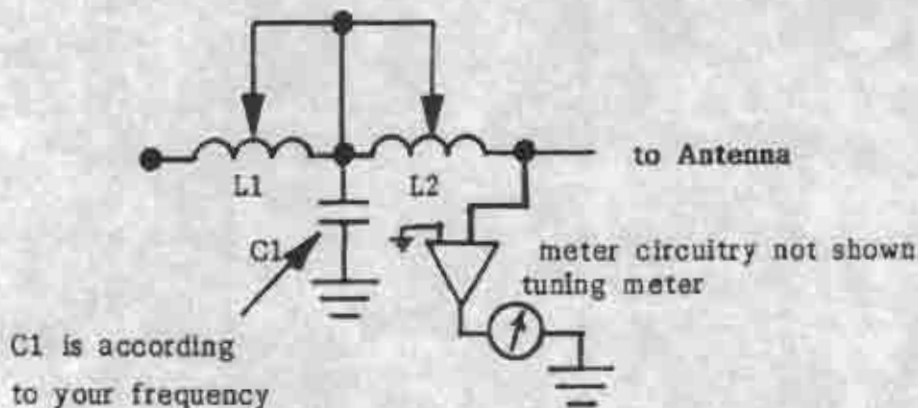

The Tuning Unit comes with its own Booklet showing how to make various Antennas from Long Wires and how to tune them for best results. Any actual "Technical Proof of Performance" for any Government Agency will still have to be done by a qualified Engineer, but in cases where this is not required, the set-up is easy and accurate.

The wire antenna varies in length from about 150 feet to over 400 feet depending upon the frequency, the lower frequencies requiring the greatest expense to build the Antenna System due to the longer wires needed. These wires can be as low as 20-30 feet above the ground and work satisfactorily, but best performance is above 30 feet. I have built Antennas as low as 15 feet which worked very well at Standard Broadcast Frequencies. A single wire is usually stretched between two or three poles (between insulators) and fed from one end. A good ground System is crucial and usually consists of 120 quarter wavelength wires buried beneath the soil going out in all directions. The Long Wire Antenna is just above these radials.

**TUNING CAPACITOR VALUES FOR STANDARD BROADCAST
FOR STANDARD "T" NETWORK AS SHOWN**

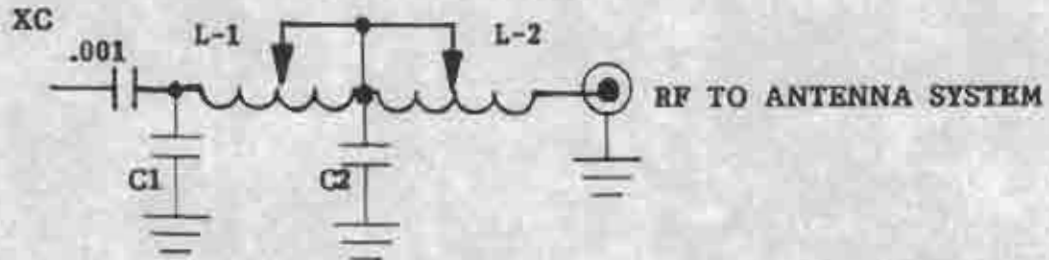

L-1 and L-2 are about 60 UH. each

FOR 1000 WATT TRANSMITTERS, WIRE SIZE IS #10 OR LARGER
FOR COILS

TUNING CAPACITOR CHART			
C1		C2	
Frequency	Capacitance	Frequency	Capacitance
1150 - 1600	300 pf.	1200 - 1600	.001
900 - 1100	400 pf. appx.	900 - 1190	.002 appx.
750 - 890	500 pf. appx.	750 - 890	.0025 appx.
650 - 740	500 pf. appx.	650 - 740	.003
530 - 640	600 pf. - .001	530 - 640	.004 - .006

NOTE: CAPACITOR VALUES ARE LESS WHEN MORE COIL IS USED
AND MORE WHEN LESS COIL IS USED.

* XC and C1 are not used for Tuning Unit Shown

TUNING YOUR ANTENNA WITH A C.B. RADIO POWER METER

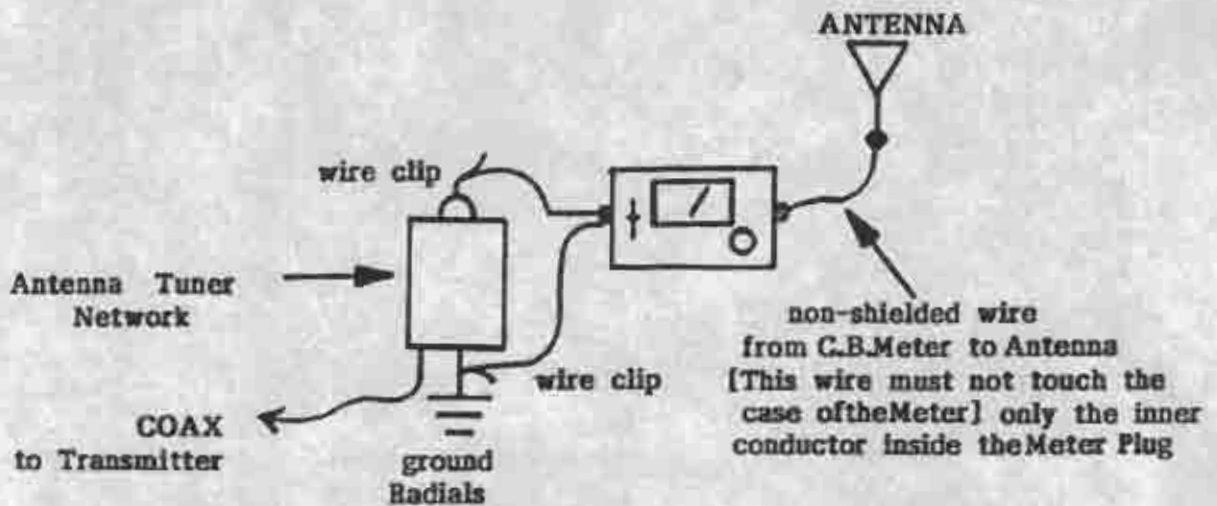

Drawing by
James R. Cunningham
(c) 1989

INSTRUCTIONS

Attach C.B. Power Meter to your Antenna System as shown at the OUTPUT of the Antenna Tuning Box where it connects to the Antenna Base Insulator (or single lead in wire).

The Meter can be any that will read RELATIVE POWER LEVELS, it does not have to read true power. Adjust the coils inside the Tuning Network for the maximum reading on your C.B. Power Meter. [Sometimes these Meters are called SWR METERS] but as long as relative power is shown, it will work.

When the coils are set for the maximum reading the Antenna is adjusted. Take the Meter out of the Circuit and connect the Antenna Lead-in direct to the Insulator or Feed-Thru coming from the Tuning Network.

This Method will work very well for just about any frequency, from 200KHz through 200 MHz.

EMERGENCY TUNING OF WIRE ANTENNAS

In case of an emergency or where a proper tuning network for the antenna is not available, it is possible to tune a wire antenna to resonance using the following methods as shown below in the diagrams.

The bandwidth is likely to suffer in some cases, and results can not be guaranteed except for 1/4 wavelength wires. However, the results are quite positive for shorter antennas such as 1/4 wavelength.

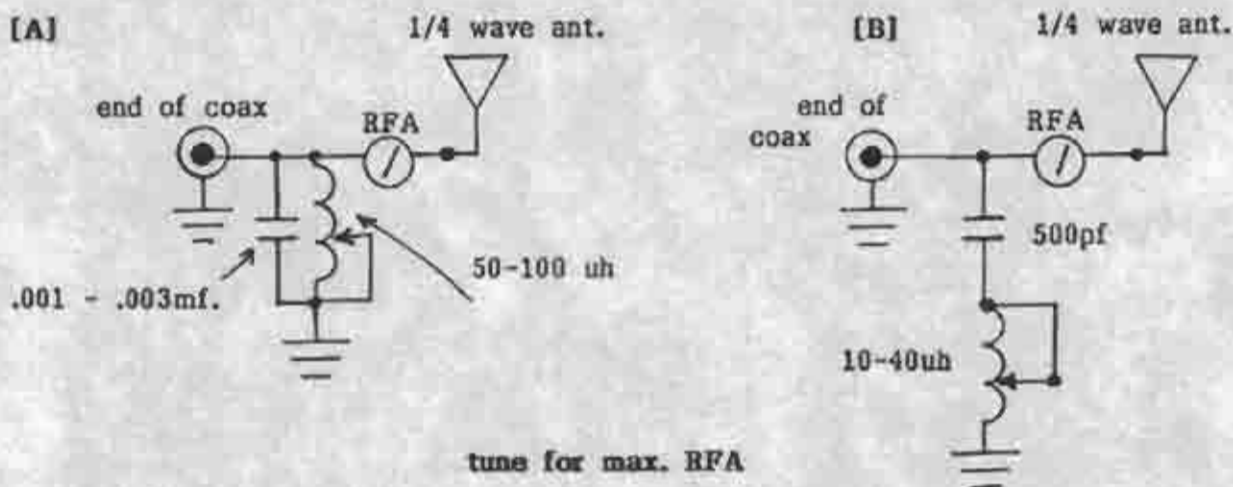

As you can see, the coil and capacitor combination is used to emergency tune the antenna at the point where the RF Meter connects to the wire. Figure A is the less preferred method due to the largest expense for parts. The diagram in figure B uses a much smaller coil and capacitor and works well with 1/4 wavelength antennas. If the coil is not adjustable, you can use an adjustable air capacitor. At powers below 100 watts, receive type capacitors will serve well. At higher powers, the capacitor must have CERAMIC INSULATION BETWEEN SECTIONS.

Chapter Four
ADVANTAGES OF AM RADIO OVER FM

1. AM RADIOS COST LESS
2. AM SIGNALS TRAVEL FARTHER. LESS TRANSMITTER POWER IS REQUIRED FOR THE SIGNAL TO REACH OUT PAST THE 60 MILE POINT.
3. STATIONS OF 1000 WATTS PERFORM THE WORK OF A 3000 WATT FM AND GENERALLY COSTS LESS TO BUILD. (THERE ARE EXCEPTIONS TO THIS).
4. EQUIPMENT IS EASIER TO BUILD BY HAND AND TO MAINTAIN.
5. MOST TUNING AND REPAIRS ARE EASIER FOR UNSKILLED INDIVIDUALS TO LEARN AND THE SHOP EQUIPMENT IS LESS COSTLY.
6. AM ANTENNA CONSTRUCTION COSTS ARE USUALLY CHEAPER, USING THE UNIPOLE ANTENNA, WHICH CAN BE MUCH SHORTER THAN A STANDARD 350 FT. FM TOWER. AM ANTENNAS MAY ALSO BE BUILT OF INEXPENSIVE WIRES, STRETCHED BETWEEN POLES.

DISADVANTAGES OF FM RADIO

1. SIGNAL DOES NOT REACH OUT AS FAR. IT IS USUALLY LIMITED TO 30-60 MILES WHEN USING A 3000 WATT TRANSMITTER, WHILE A.M. MAY "SKIP" AND BE HEARD HUNDREDS OF MILES DISTANT.
2. INSTALLATION AND FINAL TUNING IS HARDER.
3. SERVICING IS HARDER AND SHOP EQUIPMENT IS EXPENSIVE.
4. MORE PROBLEMS WITH "FREQUENCY DRIFT."
5. MOST FM STATIONS REQUIRE A MORE EXPENSIVE ANTENNA SYSTEM AND A TOWER OF AT LEAST 350 FEET IN HEIGHT.
6. MOST FM RECEIVERS ARE MORE EXPENSIVE THAN A.M. RECEIVERS.

ADVANTAGES OF FM RADIO OVER AM

1. FM GENERALLY HAS BETTER AUDIO QUALITY
2. A CHEAP FM RADIO IS USUALLY CAPABLE OF BETTER AUDIO QUALITY THAN MOST AM RADIO RECEIVERS.
3. STEREO IS USUALLY AVAILABLE WITH FM TRANSMITTERS AND RADIOS.
4. EQUIPMENT IS USUALLY LIGHTER AND COSTS LESS TO TRANSPORT.
5. HIGHER POWERED TRANSMITTERS ARE USUALLY SLIGHTLY CHEAPER THAN AM TRANSMITTERS OF SIMILAR POWER RATINGS.

DISADVANTAGES OF AM RADIO

1. STATIC IS USUALLY HEARD ON AM RECEIVERS WHEN LISTENING AT A DISTANCE.
2. STATIC MAY BE PRESENT DURING THUNDERSTORMS AND BAD WEATHER.
3. TRANSMITTERS ARE USUALLY HEAVIER, COSTING MORE TO TRANSPORT.

A VERY IMPORTANT CONSIDERATION

If the Antenna installation is to be located in an area where the GROUND WATER LEVEL is within 20 feet of the surface, AM RADIO SHOULD BE USED BECAUSE THE RADIO WAVE TRAVELS ALONG THIS WATER TABLE VERY EFFICIENTLY! It would be a very foolish decision not to use AM in a case like this. When ground water is close to the surface, even a very poor wire antenna or tower can be made to function efficiently because the GROUND WAVE will carry the Signal very far! In areas where there are HIGH HILLS not far from the desired area of coverage, THEN FM WOULD BE A WISE CHOICE, so that maximum coverage may be obtained through use of a short and inexpensive Tower located on top of a very high hill! In BOTH CASES, we allow Nature to assist us in our decisions.

EXPECTED DISTANCES
FOR
F.M. RADIO STATIONS
WITH POWERS LESS THAN 1000 WATTS E.R.P.

ANTENNA HEIGHT ABOVE AVERAGE TERRAIN	EXPECTED DISTANCE
10 feet _____	4.5 miles
20 feet _____	6.3 miles
40 feet _____	9 miles
50 feet _____	10 miles
75 feet _____	12.2 miles
100 feet _____	14 miles
150 feet _____	17.3 miles
200 feet _____	20 miles
250 feet _____	22.3 miles
300 feet _____	24.5 miles
350 feet _____	26.4 miles
400 feet _____	28.3 miles
450 feet _____	30 miles

DISTANCES ARE TO HORIZON

NOTE: Larger distances are possible with powers in excess of 1000 watts ERP.
ERP is Effective Radiated Power. ERP INCREASES AS FOLLOWS:

1. By an increase in power delivered to the antenna from the Transmitter.
2. By addition of extra BAYS (radiating elements) to the Antenna System.
3. By an increase in antenna HEIGHT.

FIGURES ARE VALID WHERE THERE ARE NO OBSTRUCTIONS
BETWEEN THE ANTENNA AND THE RECEIVER
SUCH AS MOUNTAINS, HILLS OR TALL BUILDINGS

TECHNICAL BULLETIN

FUNDAMENTALS OF FM LOW POWER BROADCASTING

EQUIPMENT:

You will Need as Follows:

1. Audio Program Material such as pre-recorded tapes, etc. for Broadcast use.
(A) You may choose to go "LIVE" and Broadcast as your own "D.J."
2. An Audio "Board" or Mixer to control audio from various sources giving your "Station" a Professional sound. Audio Sources may include: Records, C.D.'s, Tapes, or "Live" Studio performances.
3. AN F.M. EXCITER. The F.M. Exciter is a complete F.M. Transmitter usually producing about ten Watts of power.
(A) A STEREO GENERATOR to make Broadcasts in Stereo possible. Most Exciters now come with the Stereo Generator included, but be sure to ask, for you will not be able to broadcast in Stereo without it. The audio will be Mono.
4. With Ten Watts from your Exciter, you will be able to Broadcast about 6 miles in every direction if the antenna is located on the average roof top.
5. A Power Amplifier or F.M. Transmitter P.A. Unit. A 100 watt Power Amp. will boost the signal coverage to about 15 miles in every direction on a roof top installation.
6. ANTENNA HEIGHT: Raising the height of the antenna will increase coverage far more than a power raise. Going from roof top to above 75 feet will many times be equivalent to TEN TIMES THE POWER! This means that a Ten Watt Exciter will work about ten times more efficiently above 75 feet! If the antenna is placed above 350 feet, the coverage will be very good. A 100 Watt Amp. with an antenna at 350 feet (on a hill, tower, or sky scraper) will cover many Metro Areas.
7. TYPE OF CABLE TO USE:
(A) At Powers of 100 watts or less, Standard RG-8 50 ohm coaxial cable is quite efficient and is recommended. The smaller 50 ohm (C.B. Type) or 75 Ohm TV Cable System wire IS NOT RECOMMENDED due to power losses!

(B) At Powers above 100 watts, special HELIAX CABLE IS USED. This comes in various sizes from 7/8 inch beyond 6 inches in diameter. It is dry air charged to prevent moisture buildup inside. This requires A DEHYDRATOR UNIT, valves and special Fittings which increases costs significantly.
8. THE ANTENNA: There are two kinds available on the used equipment market:
(A) Horizontally Polarized (NOT RECOMMENDED). Poor efficiency.
(B) CIRCULAR POLARIZED: Modern, efficient, with good signal coverage.
9. Operation of Low Power F.M. Stations requires F.C.C. Licensing. Minorities, Educational or Religious Broadcasters receive preference for such Licensing.

USED EXCITERS



Model FX-30 Exciter

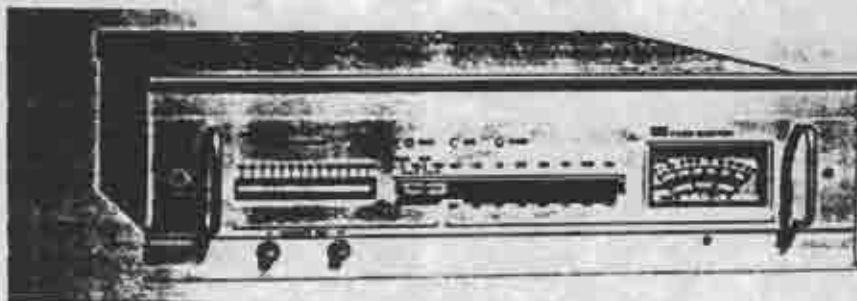

BROADCAST ENGINEERING [30 Watts]

100-W VHF Broadcasting Transmitter S 3161

BAYLY Of CANADA

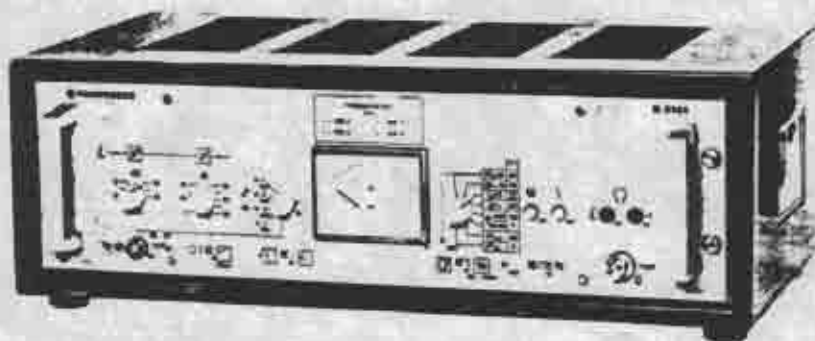

MCMARTIN

BFM-8000 1m exciter
BFM-8000T 10 watt fm transmitter

F.M.

Low Power FM Radio Broadcasting falls within the category of "LICENSED" Stations. All FM Radio Stations must be "Licensed" by the FCC before they can LEGALLY begin Broadcasting. The only exceptions are FM devices which operate within the 49 mHz. band. Such devices are capable of broadcasting about 3 miles or less (line of sight) being limited in power by the FCC.

Any Transmitter that operates within the Standard FM Broadcast Band must be licensed with the FCC or limited in power with a range under a few hundred feet (toy FM mikes, etc.).

EQUIPMENT

FM Equipment for use between 88 - 108 mHz. (Standard FM Band) is obtainable from New and Used Dealers in Radio Equipment. The Transmission Equipment needed is as follows: (1) The FM EXCITER (used cost average is \$1200) Power output ranges from 10 watts through 50 watts, (2) A Stereo Generator (if Stereo is to be broadcast) costing several hundred dollars used (the exciter will work in MONO without the Stereo Gen.), (3) FOR HIGHER POWERS the FM TRANSMITTER (actually a high powered LINEAR FM AMP) used units costing about \$900 - \$1000 for up to 250 watts of power and up to \$10,000 for a used 3000 to 5000 watt unit. The FOURTH THING will be COAXIAL CABLE and the antenna system. For powers above 1000 watts, the cost is very high. Building a properly licensed 3,000 - 6,000 watt FM Station using new Equipment currently averages \$100,000. 00!

LOW POWER FM's

The F.C.C. may (under certain conditions) license FM Stations using 10 - 250 watts power. This is sufficient power to cover many small town centers. COLLEGE STATIONS and NON-PROFIT Minority owned Stations are most likely to be preferred by the FCC for licensing! Any height tower or antenna can be used. Antennas should be (C.P.) Circular Polarized for best results.

FREQUENCIES AVAILABLE

The FCC Publishes a List of FREQUENCY ALLOCATIONS - These are frequencies known to be open for use throughout the USA in various Communities. If a frequency is not listed for your area, YOU MUST CONDUCT A FREQUENCY SEARCH USING A CONSULTING ENGINEER and apply to the FCC for permission for A CONSTRUCTION PERMIT. This tends to be expensive.

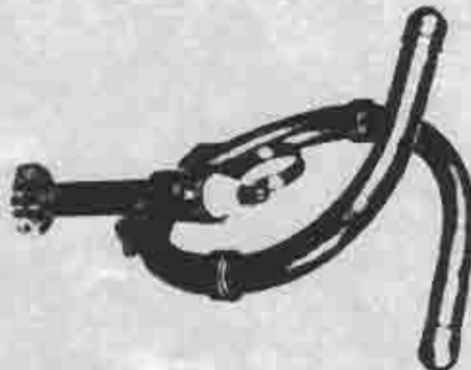

Single strand of CCA FMC circuitry patented for antenna.

BASIC INSTRUCTIONS Building An F.M. Radio Station

The FM Station may be a Class A,B, or C. The Class A Station has an E.R.P. (Effective Radiated Power) of 6000 Watts or less. The Class B Stations have an ERP of 50,000 Watts with an Antenna Height of 500 feet above average terrain (AHAAT). A Class C Station has a power of 100,000 Watts with an AHAAT of 2000 feet! The Class A AHAAT is 300 feet. MINIMUM power for a Commercial FM Station is 100 watts. Commercial Stations operate on an assigned frequency between 92 and 108 MHz. The Non-Commercial Station must operate in the lower part of the band between 88.1 MHz and 91.9 MHz.

FREQUENCY SEARCH

You may hire a Consulting Engineer to do the work for you or do the work yourself where possible.

1. Obtain a list of all FM Stations with a 50 mile radius. If there is a frequency that is not assigned and the three channels either side of it are not assigned or are assigned to Class D stations you have found the Channel to use.
2. If you can not do the above, you may request a list of the Frequency Allocations for your area from the FCC. If there is one listed, you may apply for it. If none is listed, a Consultant may be needed to do a frequency search for you and to make application to the FCC.
3. If no frequency is available, the only alternative is to buy an existing Station or to re-locate.

FCC FORMS:

Non-Commercial Stations: Request several Form 340's from the FCC. Commercial Stations must use Form 301.

A. Non-Commercial License is granted only to a Legal Entity such as a School or Church. There must be a Governing Board.

B. With the help of a Consulting Engineer, fill out the Forms and return them to the FCC with the required Fees. You normally will get a response within 90 days.

LOW POWER FM BROADCASTING

When we consider Low Power Broadcasting, nearly everyone wants to get into the overcrowded FM Band. The reason is in order to achieve better audio quality and lighter weight equipment. The only drawback is COST! FM Equipment is staggering in cost! A Ten Watt Exciter with Stereo Generator may cost over \$6000 new and \$4000 USED! Equipment capable of higher power levels will cost even more! In order to circumvent these expenses, various experimenters have tried to adapt Aviation Equipment, Mobile Transmitters, Experimenter's Kits and even toy FM Mikes to use in the FM Band.

Unless a person has the money for professional equipment, he may end up very disappointed! Cheap Kits, and obsolete equipment seldom performs well even for Experimenters due to the following reasons:

- [1] FREQUENCY DRIFT (This is the most common fault with cheap Equipment).
- [2] EQUIPMENT FAILURE TO MEET SPECS. (Almost ALL Kits do this).
- [3] F.C.C. WILL NOT TYPE ACCEPT (A few quality Kits are in this Catagory). They do not want Kit Makers and Builders experimenting in the Broadcast FM Band. The F.C.C. is pushing hard to stop this!
- [4] OLDER STYLE EQPT. IS OBSOLETE! Many old FM Exciters require more time in the Repair Shop than "On The Air." This is especially true of some tube type Units and older Solid State Exciters.

BUILD IT YOURSELF?

If you have PLENTY of time, money and brains, you can build your own Broadcast Quality Exciter and have it Approved for use at a Licensed Station. This is going to prove a task requiring the highest degree of talent and ability. Some of the best design work has originated in someone's home shop, but you had better think twice if you imagine it will be easy to build your own. You will run into problems with Frequency Multiplication Stages, Tuning and especially layout unless you have in depth training in Design.

CONCLUSION! There is NO EASY CHEAP WAY TO OBTAIN A HIGH QUALITY EXCITER, NOT EVEN IN A KIT!! If you find one, LET ME KNOW!

HI-FI Broad-band EXCITER/TRANSMITTER (AM BAND)

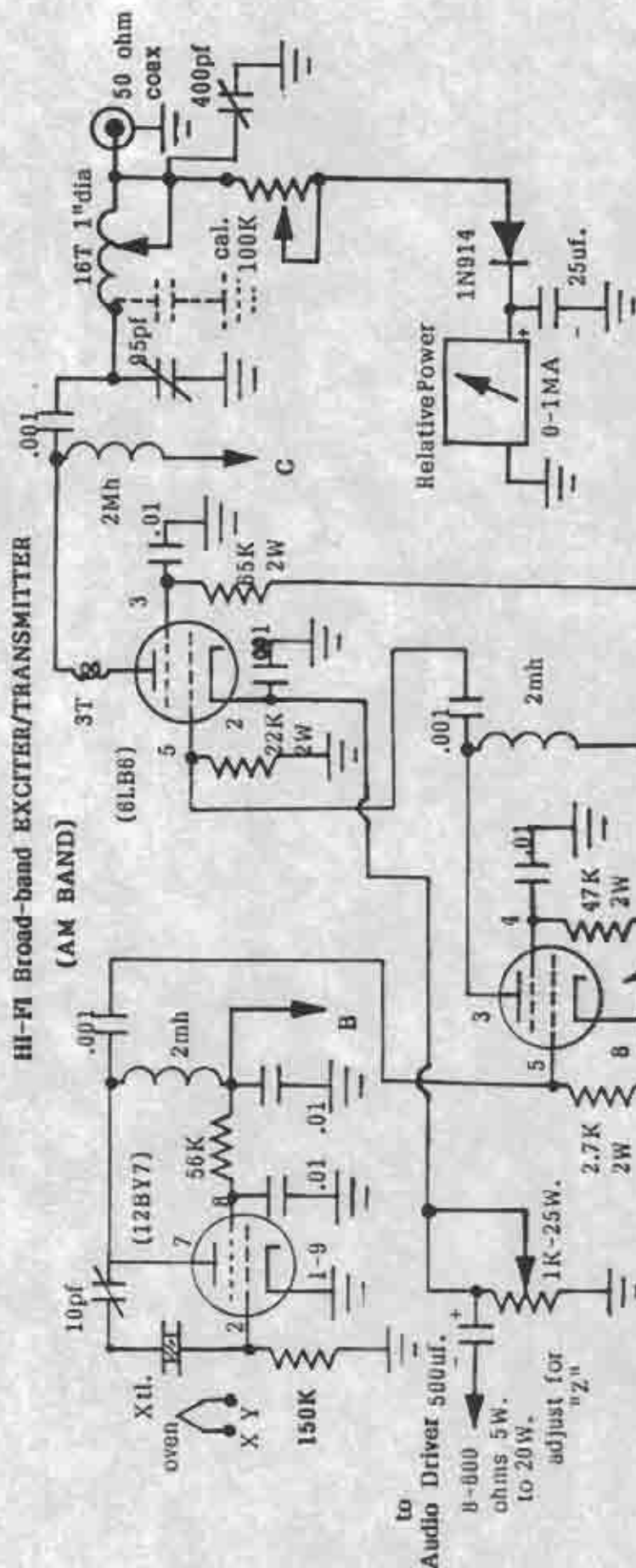

RF FREQUENCY RANGE: 1.5 - 30 Mhz
 AUDIO RESPONSE: 15-20KHZ (actual)
 or to limits of Audio Amp. Driver

CRYSTAL: ICM #4522101 cs by
 CUNNINGHAM 75° C.

DESIGNED BY James R. Cunningham
 (c) 1983

LOADING CAPACITOR (in dotted lines)
 is according to frequency and is NOT
 USED IN MOST APPLICATIONS

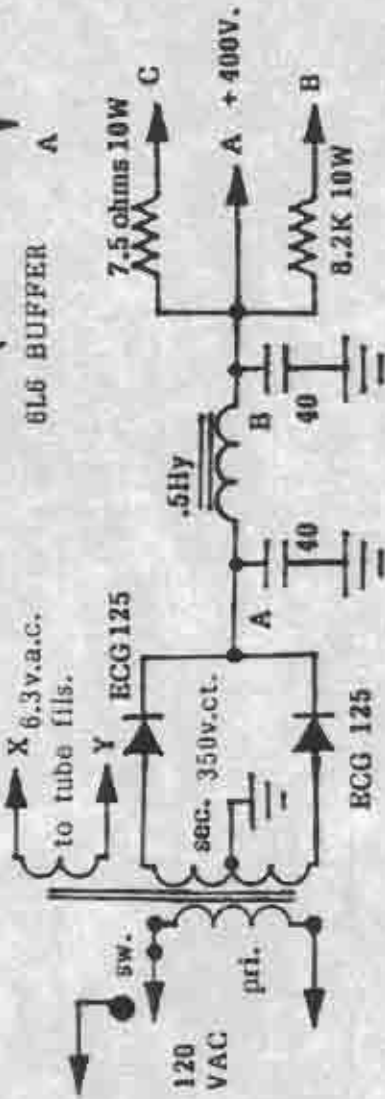

Power Output:
 35 - 70 Watts (depends on skill of Builder)

**BROADCAST QUALITY A.M.
TRANSMITTER
10 Watts**

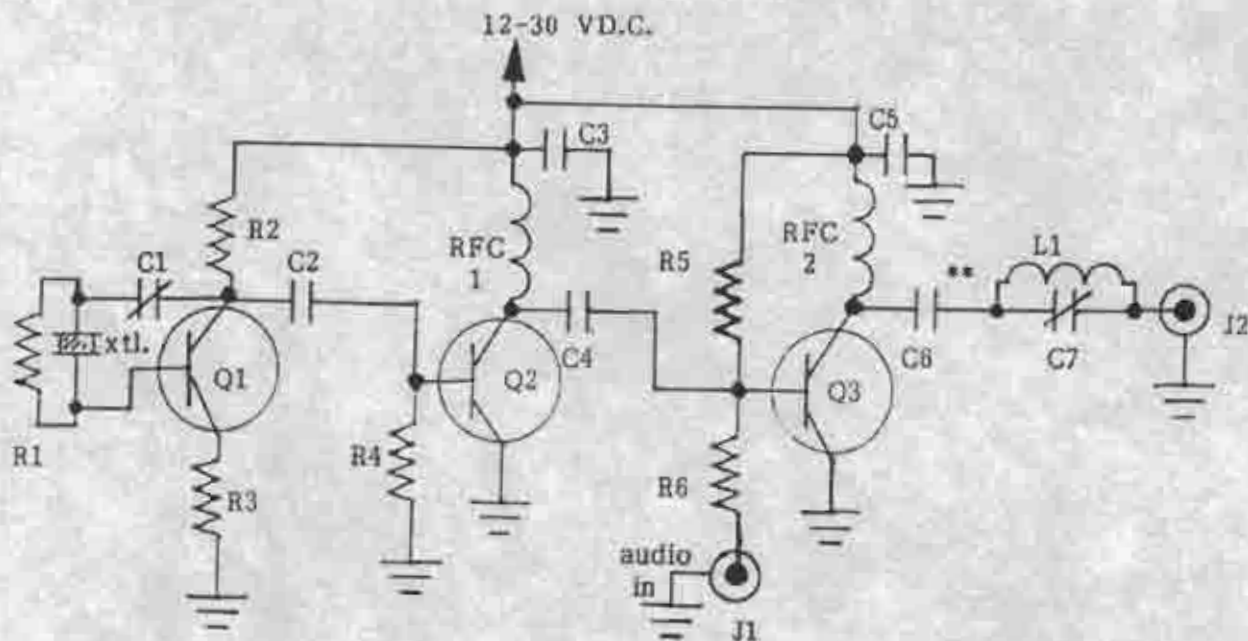

PARTS

XTL. - 20 Pf. Load, HC-8 Holder Style Standard Broadcast Crystal

R1 - 1 meg. 1/2 Watt Carbon Resistor

C1 - 300 pf. trim capacitor, C2-.001 disc cap., C3-.01 disc., C4 - .001 Disc., C5 - .01 disc. capacitor, C6-.001 disc., C7 - 500PF. trim capacitor.

** L1-C7 tuning network - coil is 20 - 30 Uh air coil (wind 30 Turns #18 ga. bell wire on a 4 inch long 1/2 inch dia. pvc pipe section) Tune C7 for max. output into the antenna or load (Transmitter will work without L1-C7, but will have less output).

R2 - 10K, R3 - 4700, R4 - 470K, R5 - 150 - 200K, R6 - 56K (all are 1/2W.)

RFC 1 & 2 (1-2.5 Mh. RF Chokes)

J1 - RCA Jack, J2 - SO-239 Jack for 50 ohm coax or suitable antenna plug.

Q1 - ECG 123AP, Q2 - ECG 123AP, Q3 - ECG 130 on heat sink

NOTES: Tune C1 to crystal frequency. Power supply should be regulated. Audio may be taken from mixer output or from a suitable limiter, L1-C7 may be substituted with a Pi or Tee Network for best harmonic suppression, and R6 may be substituted with a 100K Pot. to match professional audio Sources.

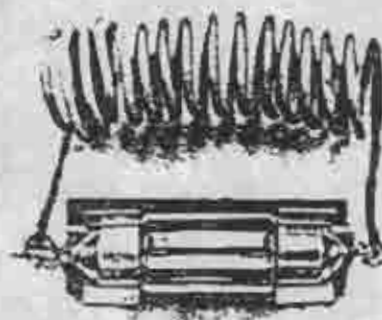
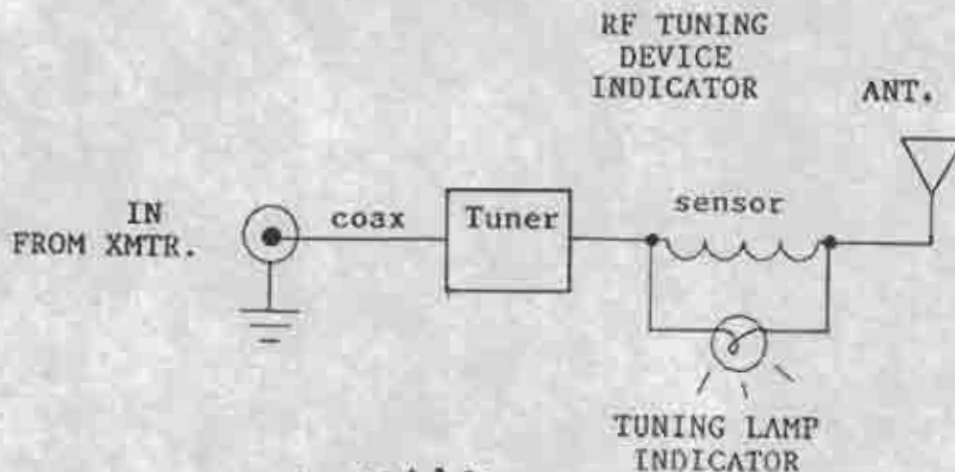

for AM and Short Wave

THEACTUAL SIZE PHOTO

This device may be placed between the Antenna tuner and the Antenna itself, at the point where the lead in wire attaches to the tuner. When maximum RF Current is found, the lamp will be at its maximum glow. After the Antenna is tuned, the lamp may be removed, or left permanently in the circuit.

PARTS

The sensor wire consists of 5-15 turns of #18 - #10 coated wire, depending on how much current is to be drawn into the antenna system. This is coiled into 1/4 inch to 3/4 inch diameter coil. Across it is placed a small lamp such as the R5604 dome lamp, the type used in automobiles. This is shown mounted in a fuse block (sold at auto departments in stores). This is isolated from grounds and shorts. The device consumes almost no power and may be left in the circuit after tuning is accomplished. The actual resistance of the total assembly is about .2 ohms and works well for frequencies up to 3 MHz. At frequencies higher than this, the number of turns should be reduced to 2-7 turns, depending on the frequency of operation (30 MHz upper limit for the device).

MODULATION PERCENTAGE "FLASHER"

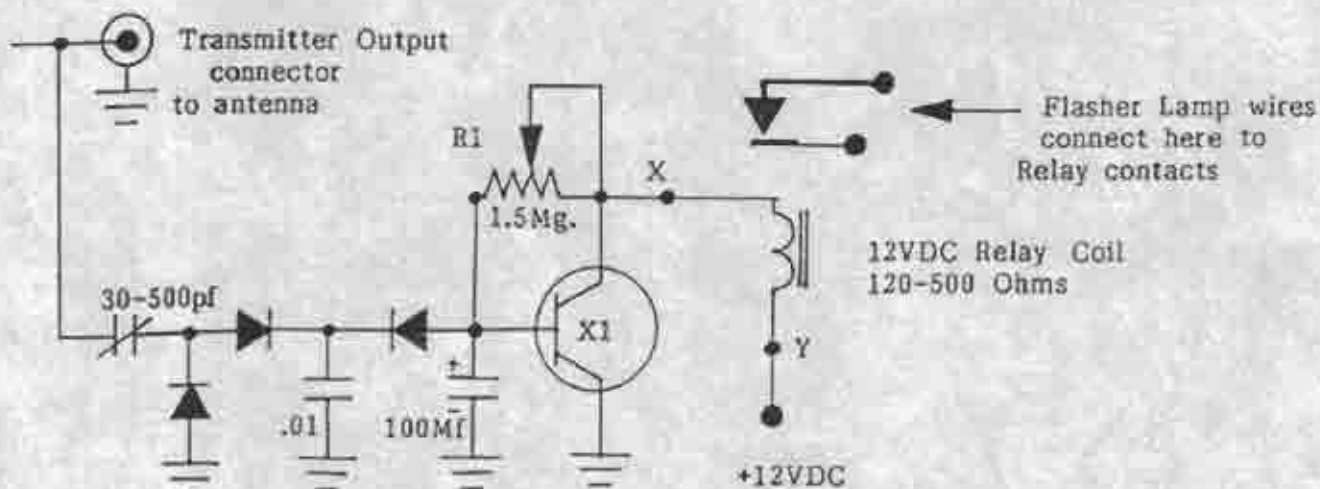

PARTS:

DIODES: 1N914 or Eqv.
X1-TRANSISTOR: ECG 123 or other General P. Style
Voltage ratings for capacitors: 50VDC or better

NOTES:

At points "X" and "Y" a 12 Volt, 120 ohm lamp may be connected instead of the 12 Volt Relay, for provisional service. R-1 is adjusted for the best "flashing" operation at the desired modulation point (such as 125%).

The 30-500 pf capacitor may be a fixed value for Standard Broadcast Frequencies at 500 Pf/300 Volts or better. This capacitor must be in the area of 30 pf or less for higher frequencies.

INSTRUCTIONS

Wire the input of the unit to the output connector of the radio transmitter. Do not disturb the normal antenna or dummy load connections. Make connection to the MODULATION PERCENTAGE FLASHER inside the radio itself. Adjust R-1 for "flashes" on your flasher lamp (not shown) at 100-125% level, using a "scope" to confirm accuracy. The Relay will turn "on" and "off" accordingly.

ADDRESSES OF DEALERS

ANTENNA EQUIPMENT - PHASORS - COILS - NEW R.F. CAPACITORS

1. KINTRONICS

P.O. BOX 845 Tel. (615) 878-3141
Bristol, Tn. 37621-0845

2. COSMIN Electronics

P O BOX 222
Pipersville PA 18947 215-847-2044

3. J S BETTS Co. ALSO HAS LARGE PARTS INVENTORY FOR HAMS, etc.

P O BOX 426
FAIRBURN GA 30213 404-964-3764

4. EAGLE HILL ELECTRONICS (specializing in surge protectors)

41 Linden Av
Rutledge PA 19070 215-544-8879

5. ANDREW CORP. Highest quality antennas and accessories

10500 W 153rd Street
ORLAND PARK IL. 60462 312-349-3300

AUDIO EQPT. AND PROFESSIONAL BROADCAST STUDIO ITEMS

1. L.T. SOUND (Production Room Eqpt.) very good

P O Box 338
Stonemountain GA 30088 404-493-1258

2. LAUDERDALE ELECTRONIC LABS. (Broadcast Eqpt.)

18 SW 13th Street
Ft Lauderdale, FL 33315 305-764-7755

AUDIO EQPT. (cont'd.)

3. BSW

7012 27th Street West
TACOMA WA 98466 1-800-426-8434

4. ALLIED BROADCAST EQPT.

Suite 309 Chaddick Center 1201 E 15th Street
Plano TX 75074 317-935-5193

5. BRADLEY BROADCAST SALES

15555 L Frederick Rd
Rockville MD 20855 301-762-9222

6. BROADCAST ELECTRONICS

4100 N. 24th Street
Quincy IL 62301 217-224-9600

7. PROFESSIONAL AUDIO SUPPLY

5700 E Loop 820 South
Ft Worth TX 76119-7050 (817)483-7474

8. LONG'S ELECTRONICS (AUDIO VISUAL NEEDS)

2700 Crestwood Blvd
Birmingham AL 35210 1-800-633-3410

CAPACITORS

1. JENNINGS CAPACITORS (including vacuum type)

SURCOM ASSOCIATES
305 Wisconsin Av
Oceanside CA 92054 619-722-6162

2. PLASTIC CAPS. INC.

2623 N Pulaski Rd
Chicago IL 60639 312-489-2229

PARTS AND TEST EQUIPMENT

1. MOUSER ELECTRONICS

2401 Hwy 287 North

Mansfield TX 76063 817-483-4422

2. FORDHAM RADIO

855 Conklin St

Farmingdale NY 11735 516-752-0050

3. INTERNATIONAL CRYSTAL (crystals only) HIGHLY RECOMMENDED

10 N. Lee

Oklahoma City OK 73102 405-236-3741

4. CRYSTEK (crystals only)

1000 crystal Dr.

Ft Myers FL 33908-6135 813-938-2109

5. BIRD ELECTRONICS (watt meters and dummy loads)

802 "B" Olde Hickory Rd

Lancaster PA 17601 717-569-0487

6. CONSOLIDATED ELECTRONICS (small parts & Test Eqpt.)

705 Watervliet Av

Dayton OH 45420 513-252-5862

7. MCM ELECTRONICS (similar to above) reasonably priced

858 E Congress Park

Centerville OH 45459-4072 513-434-0031

RECEIVERS
SURPLUS ELECTRONICS

1. FAIR RADIO SALES (true Gov't. Surplus) reliable-dependable (many parts)
1016 E Eureka Street
Lima OH 45802 419-223-2196 or 227-6573
2. DAVILYN CORP. (another good source for Hams, etc.)
13406 Saticoy St
N Hollywood CA 91605-3475 (818-787-3334)
3. H and R CORP. (robotics parts, microwave and test eqpt.)
401 E Erie Av
Philadelphia PA 19134 215-426-1708
4. OCEAN STATE ELECTRONICS (excellent Source)
P O BOX 1458
WESTERLY, RI 02891 (1-800-866-6626)
5. MARLIN P JONES AND ASSOCIATES (priced right)
P O BOX 12885
LAKE PARK FL 33403-0685 (305-848-8236)
6. ALL ELECTRONICS CORP.
905 S Vermont Av
LOS ANGELES CA 90008 213-380-8000
7. BAYTRONICS (used military radios for Ham use)
P O Box 591
SANDUSKY OH 44870 (write for catalog)
8. LECTRONIC RESEARCH LABS. (high class new and used test gear)
ATLANTIC and FERRY AV
CAMDEN NJ 08104 609-541-4200

TRANSFORMERS

1. PETER DAHL CO.
5869 WAYCROSS
EL PASO TX 79924 915-751-2300
2. SEE SURPLUS AND PARTS DEALERS (large transformers will be under SURPLUS)

TRANSMITTERS

1. HARRIS CORP. (BROADCAST TRANSMITTERS)
P O BOX 4290
QUINCY IL 62305 1-217-222-8200
24 hour toll free for parts for HARRIS-GATES EQPT. 800-422-2218
2. CROWN BROADCAST
1718 W. Mishawaka Road
Elkhart, IN 46517 (219) 294-8000
3. OMNITRONIX
1374 Cinnamon Drive
Ft. Washington, PA 19034
215-542-9580
4. CONTINENTAL (specialists in high power transmitters for short wave)
P O BOX 270878 (Office: 4212 S Buckner Blvd.)
DALLAS TX 75227 214-381-7161
5. SWR, Inc.
P O Box 856
Ebensburg, PA 15931-0856
(814) 472-5436

TUBES

1. ELMIRA (smaller tubes and transistors) Factory new WESTINGHOUSE tubes
P O Box 4230

Southside Station, Elmira, NY 14904 607-734-6114

2. CORNELL (small tubes cheap)

4215 University

San Diego CA 92105

3. ECD INDUSTRIES (large power tubes)

2034 Armacost Av

LOS ANGELES CA 90025 213-820-3009

4. PLASTICS TECHNOLOGY, INC.

SOLID STATE RECTIFIERS for Transmitters

205-633-6277

5. Aero Electronics (power tubes for Xmtrs.)

2129 Venice Blvd.

Los Angeles CA 90006 213-737-7070

6. EIMAC-VARIAN (High quality)

301 Industrial Way

San Carlos CA 94070 415-592-1221

801-972-5000

also 1678 S Pioneer Blvd.

Salt Lake City UT 84104

7. ECONCO (rebuilders)

1318 Commerce Av

Woodland Ca 95695 916-662-7553

8. Richardson -CECO

2115 Av "X"

Brooklyn NY 11235 718-646-6300

9. UNITED PAGE(large power tubes)
558 St Charles Dr Suite 215
Thousand Oaks CA 91380 805-497-8991

11. Surplus Sales of Nebraska
1315 Jones St.
Omaha, Nebraska 68102
1-402-346-4750

10. Freeland Products (rebuilder)
Rt 7, Box 628
COVINGTON LA 70433 504-893-1243

IMPORTANT NOTE

These are only a few of the Suppliers, but these I have dealt with and have found them reliable. It is important to note that Companies come and go, usually merging with other Corporations, and by the time you get this Book, all of the above may not be in business. Hopefully you will find enough information here to be helpful, making whatever Project you chose to do fully possible.

EQUIPMENT LIST
FOR LOW POWER FM STATIONS
MINIMUM REQUIREMENTS

1. ANTENNAS - Antenna must be Type Approved by the FCC. It may be at roof top level for Low Power FM (under 35 feet) or if higher, the FCC will calculate the amount of Power which can be run into the Antenna to achieve 100 Watts ERP. (Maximum allowable for LPFM).
 - A. Recommended Antenna Bays - 2 Circular Polarized Bays for UNITY GAIN. A Popular Antenna due to it's price and availability is: OMB no. MP-2-.8K available at Progressive Concepts (630)736-9822 for \$695.00.
2. The Transmitter consists of 3 parts:
 - A. 10 Watt Exciter (Mono)
 - B. Stereo Generator
 - C. RF Power Amplifier (FM) 150 Watts (This power is needed because there is loss in the Fittings and in the Coax to the Antenna)I provide these all together in a single Package for \$2600.00. This Assembly is FCC Type Approved and is about \$500 + \$2500.00 less than other makes.
3. Audio Processor - I have found a good Processor for LPFM at a very low Cost The MDX1200 "Autocom" by Behringer. \$190.00.
4. MIXER - I am taking for granted that the user already has a Mixer. If not, I recommend one of the Radio Shack Mixers or any other Stereo Mixer with "Line Output" provision.
5. Coaxial Cable - For short runs use RG-8 available at 2 Way Radio Dealers. Do NOT use CB Coax for this!
6. TOWERS - Standard ROHN 25G is recommended at \$90.00 per 10 foot Section at 2 Way Radio Dealers. This Tower (if used) should clear Roof Top Levels because FM is "Line Of Sight." Towers should not exceed 75 feet for Low Power FM.

LOW POWER FM LIST

"continued"

7. LOW POWER FM STATIONS are required by Law to Operate EAS Equipment. EAS (Emergency Alert System) alerts people in case of State, Local or National Emergencies. This Equipment is Expensive and requires 2 FM Receivers to connect to it. These Receivers are inexpensive and can be purchased at Radio Shack.

EAS SYSTEMS - The EAS System runs about \$3000. There are 2 commonly available: (1) BURKE EAS with Audio Switcher (2) TFT EAS911 with EAS940A Program Interrupt Module.

This Equipment is REQUIRED by the FCC.

8. FM MODULATION MONITOR - Commercially available at \$2500.00 or a substitute can be made from commonly available Radio FM Receive Eqpt. and "VU" Meters for around \$700.00. This Eqpt. must be "Calibrated."

9. Station "LD." at the top of each hour must be automated if Station is not "live" operated by a D.J. I recommend a Computer (Pentium) with "Automate" Program (around \$500.00). The Computer is extra. This will allow for full time automation, music on hard drive, thousands of songs, sermons, etc. all can be moved around to various time slots, assigned to different days, etc. by viewing on the screen and "clicking." The System will operate like a fully "manned" Station once set up; complete with Station "LD.'s" and Announcements timed to the second. Automate can be interrupted at any instant for "Live" use.

10. FILING FEES - There are no filing fees for LPFM non profits.

11. Studio Eqpt. such as CD Players, Cassette Decks, D.J. Mikes, Headphones, Turn Tables (optional) and Inner connecting cables can be purchased Locally.

For
FOREIGN USE ONLY!

SPECIAL COAXIAL ANTENNA
for
FM RADIO SERVICE

The special coaxial antenna, as illustrated below, effectively multiplies the FM Radio Signal by a factor of *10! Using the FM Stereo Transmitter of 30 watts Power, your Radio Signal will have an Effective Radiated Power (ERP) of 300 watts! This is enough power to cover many small Towns and Rural Areas, even some Cities! When the Antenna (shown below) is mounted at a height of only 350 feet above average terrain, an area of coverage of up to 10 miles is commonly reported. If the antenna is mounted at a lower level, this distance will not be as large, but good coverage can still be expected in most cases.

When the Antenna, shown below, is used with the 300 Watt Transmitter, the expected coverage dramatically increases! An EFFECTIVE RADIATED POWER of 3000 Watts will then be present!

Using the COAXIAL ANTENNA at LOWER levels is possible, but with reduced amounts of coverage for the Radio Signal. *INCREASES OF HEIGHT ABOVE 350 FEET WILL RESULT IN EVEN GREATER POWERS AND MUCH LARGER AREAS OF COVERAGE! This is often practical, where HIGH BUILDINGS OR HILLS can be used to position the Coaxial Antenna above the Service Area.

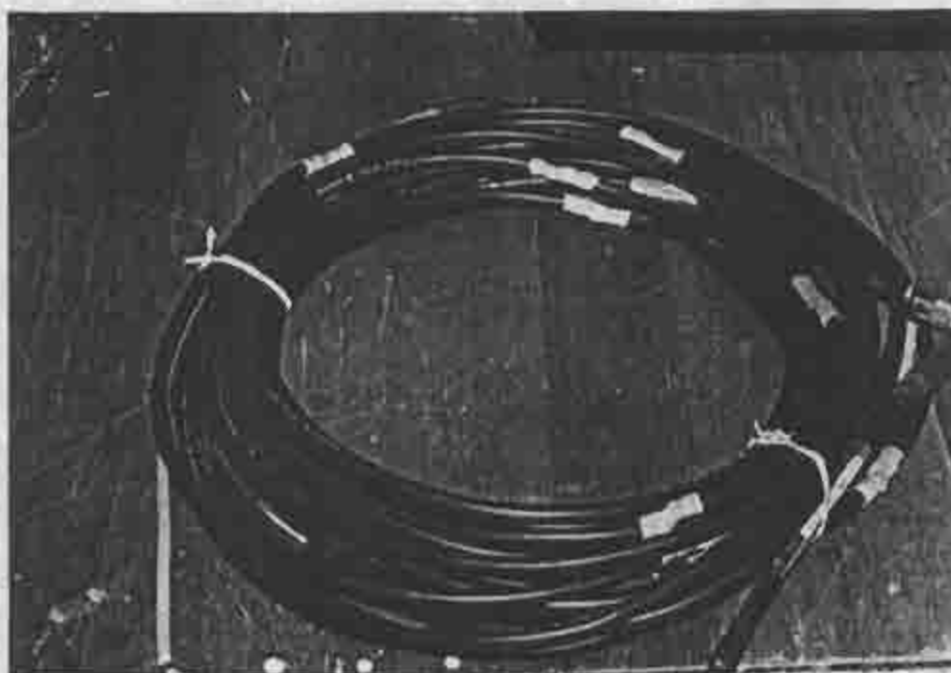

MULTI BAY ANTENNA

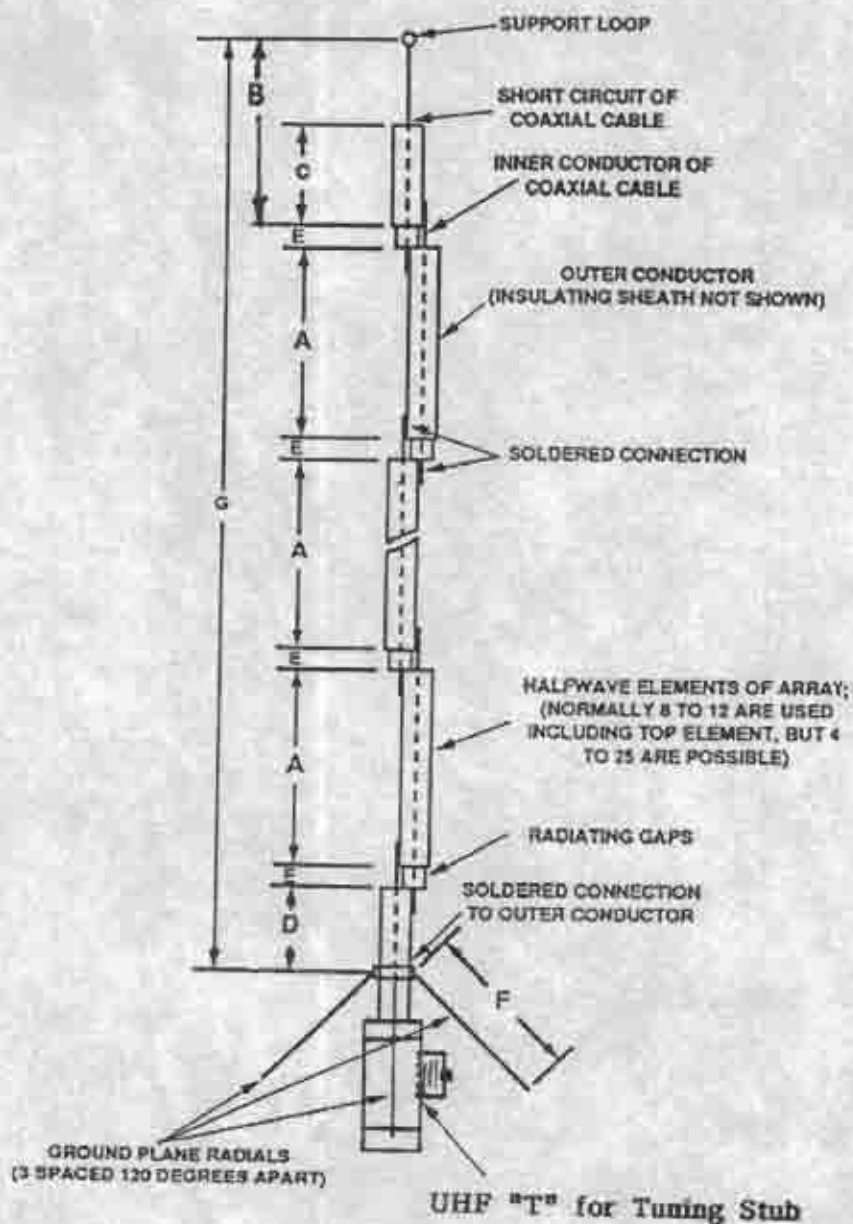

MULTI BAY COAXIAL ANTENNA

1. **MATERIALS** - RG 8 coaxial cable and standard accessories

2. **DIMENSIONS:** $A = 330/F \text{ MHz}$.

$$B = A \times 1.21$$

$$C = A \times .5$$

$$D = A \times .41$$

$$E = 3/16 \text{th inch}$$

$$F = A \times .83$$

Prepared by
James R. Cunningham

3. **NO. BAYS** - UP TO 25 [GAIN = appx. .5db per BAY] 20=10db

ILLUSTRATION

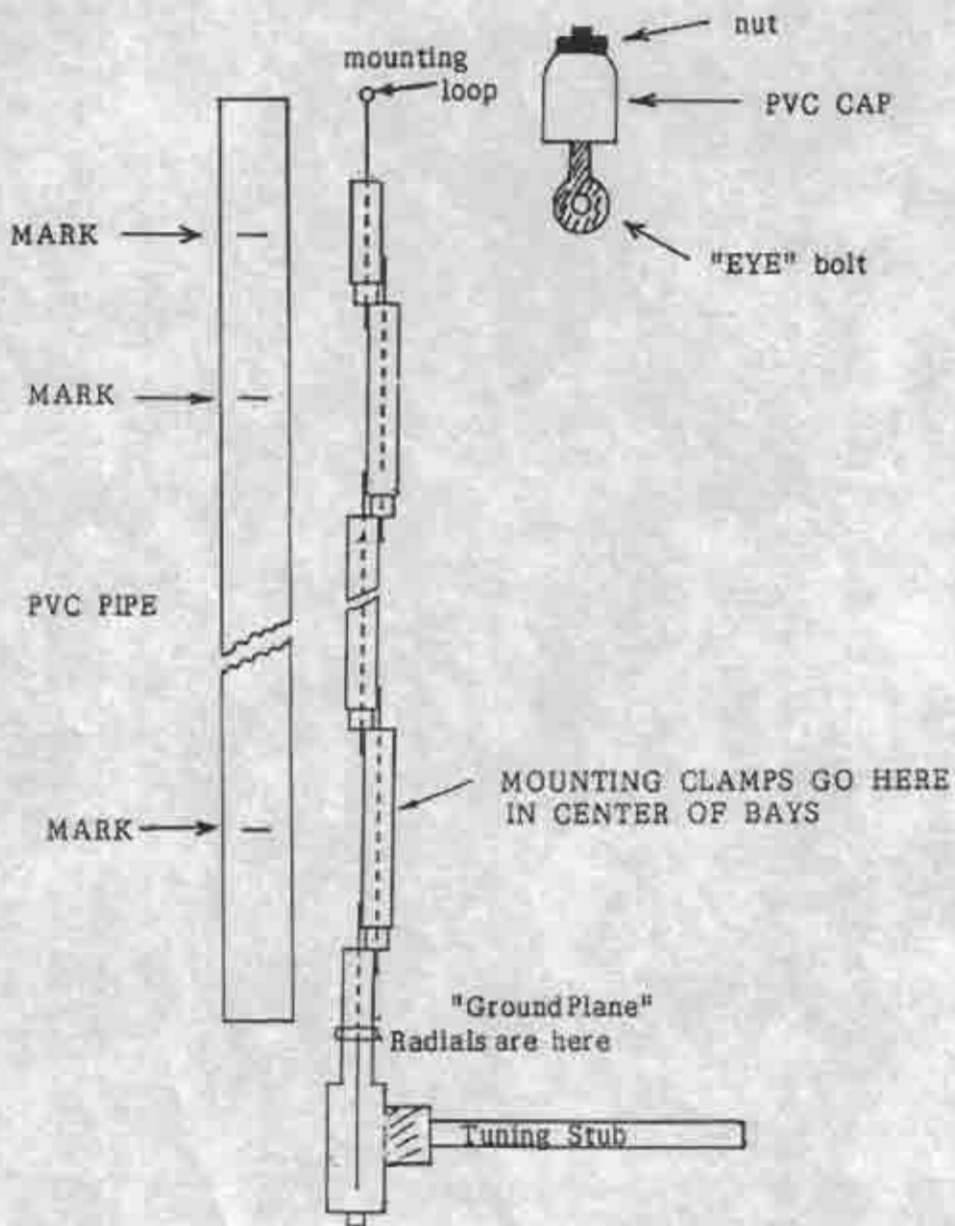

Lay the PVC Pipe Sections along side the Coaxial Antenna [on the ground] and MARK where the clamps will go on the PVC Pipe. CLAMPS MUST GO BETWEEN BAYS [IN CENTERS] AS SHOWN. The clamps and the PVC PIPE SECTIONS will all mount on the Tower FIRST, then the COAXIAL ANTENNA will be pulled up through the PVC Pipe using the MOUNTING LOOP. This LOOP is attached to the PVC CAP "EYE" with wire or a bolt, nut and washer. The PVC CAP is allowed to come down in place over the uppermost PVC Pipe Section. DO NOT GLUE THE CAP IN PLACE - GRAVITY WILL HOLD IT SUFFICIENTLY. In case the coaxial antenna ever needs to come out of the PVC Pipe, it will then be possible to remove the PVC CAP TO SERVICE THE COAXIAL ANTENNA.

center of
Radiation →

22.86 M.
75 ft. length
Coaxial/colinear Antenna
Bays (20)

Transmission Line Length
100Meters
Type: Andrew LDF-50A
Loss: 1.2 db. (100M.)

100 M.
328 ft.
above average
Terrain

The 20 Bay Coaxial/Colinear Antenna
when used as shown will produce an
"ERP" of 3000 watts when driven with
only 300 Watts of input power at
88-108 Mhz.

James R. Cunningham Transmitters
P.O. Box 8, Stonewall, OK 74871
FCC Lic. # PG 10-21117

Dwg. No.	20 Bay Coaxial Antenna	Date
1:18:94	10 db. Gain Minimum	1/18/94

NOTES:

The 20 Bay Coaxial/Colinear Antenna is Vertical in Polarization, Omnidirectional in Pattern and varies in length from 70 to 75 feet. The entire coaxial Antenna is encased, by the user, in PVC conduit or pipe for protection from weather.

Engineer-James R. Cunningham (USA)

DIRECTIONAL BEAM ANTENNA

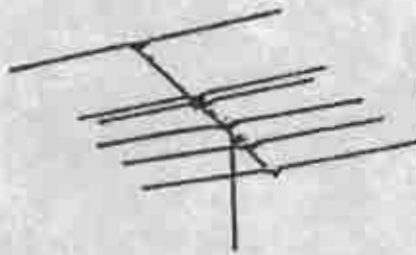

High gain
FM-stereo antenna

This inexpensive F.M. Receive Antenna can be used as an effective TRANSMIT Antenna at powers up to 1KW (intermittent) and 300 Watts Continuous!

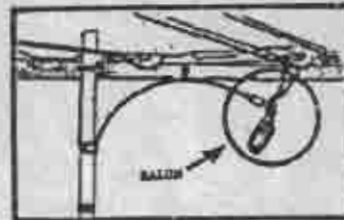

Use the Special Balun shown below, AIM THIS HIGHLY DIRECTIONAL ANTENNA IN THE RIGHT DIRECTION and your Transmit power (ERP) will MULTIPLY at least BY TEN!

BROADBAND 88-108 MHZ TRANSMIT BALUN DEVICE

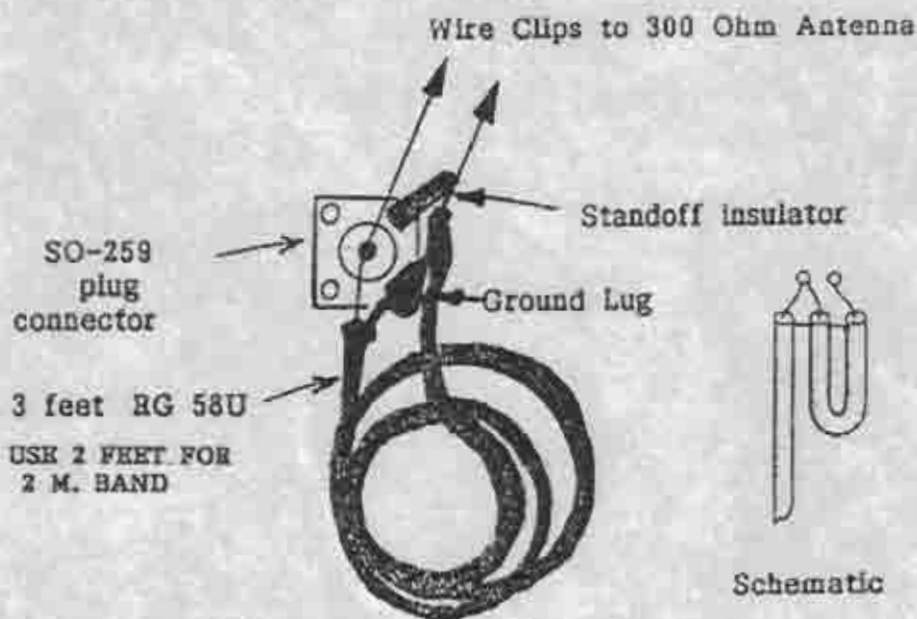

BALUN COIL FOR MATCHING 72 Ohm or 50 Ohm coax to a 300 Ohm Antenna for Receive or Transmit purposes.

NOTES: RG 8 cable may be used for the Balun if over 300 Watts of power is to be run into the Antenna.

The length of the coil of Coax is 1/2 Wavelength with the Velocity Factor of the line included in the calculation.

FOAM COAX - VF=.8

POLYETHELINE COAX - VF=.66

MORE ABOUT KITS

It is possible to buy a 100 MW Kit, add several stages of RF Amplification, and come out with almost any power at FM, 2 Meter, or other Frequencies. This is often done for use in many Countries in order to obtain an economically priced Radio Transmitter. Some of the Companies that sell Kits are listed below. You may wish to request their Catalogs.

1. RAMSEY - 1-800-446-2295
2. Free Radio Berkeley c/o Steve Dunifer 1442 A. Walnut St. #406, Berkeley, CA 94709 VOICE MAIL - (510) 464-3041 (Request Catalog)
3. ALL Electronics 1-800-826-5432
4. Marlin P. Jones 1-800-432-9937
5. DC Electronics 1-800-467-7736
6. Dalbani 1-800-325-2264
7. MCM 1-800-543-4330
8. Parts Express 1-800-338-0531
9. JDR 1-800-538-5000

DC Electronics has a good Kit called "The Stereocaster" which is less than \$30.00, has Stereo, and is reliable and stable. It is a good 100 MW Unit, and has been used as the heart of higher power transmitters for Export.

Possibly the best FM Kit is made by Ramsey. The FM 25 is Broadcast Quality for 129.95 in Kit form. These are used in many Nations as the heart of high powered systems by adding several Stages of RF Amplification. They offer a "Super Pro" FM Radio Station which has a built in Limiter, LED Readout, with Mixer Controls, etc. which is perfect for the College Campus Radio Station. See the information in this Book on College Campus Stations for applications for use of higher power Transmitters which may be LEGAL for use in the USA - (Schools, Camps, Churches, Drive Inns, Hotels, Nursing Homes, Correctional Facilities, etc.).