

# HARDENING POWER SUPPLIES TO LINE VOLTAGE TRANSIENTS

Originally presented at the Power Electronics Design Conference, October, 1985, Anaheim, California  
Also published in Power Conversion & Intelligent Motion, June, 1986

## Abstract

The power line transient environment is described. Transient voltages on the DC output of off-line rectifier/filter designs are shown. Protection schemes are discussed. An integrated rectifier/transient suppressor circuit is suggested as a cost-effective means of rendering the DC bus virtually immune to line transients.

## Introduction

Unexpected line voltage transients are finally being recognized as a significant factor in the failure of Switching Mode Power Supplies (SMPS). As stated in a recent Navy publication<sup>1</sup>: "The most predominant power supply failure modes are caused by peak in instantaneous transients and subtle factors within and external to the power supply . . . The following is a list of key points to consider when designing and evaluating a switching-mode power supply design: (1) Put voltage transient protection on the input power line."

Until the publication of IEEE Standard 587-1980<sup>2</sup>, now ANSI-IEEE C62.41, the designer of off-line SMPS was unsure of the ac line transient environment. Now switching power supplies can be designed to meet this standard and pulse generators are available which produce the waveform specified. The standard specifies that low impedances across the line in commercial and industrial environments should handle an 8/20 current wave-shape (double exponential, 8 $\mu$ s rise time, 20 $\mu$ s decay to half of peak) having a peak amplitude of 3000A.

It should be understood that lightning induced transients propagate through a system as a current source looking for a low impedance path to ground. It is unlikely that most designers make provision for the rectifier and filter system to handle pulse currents up to 3000A, but a conservation design philosophy indicates that this should be done. The task is not easy, because component manufacturers do not generally consider this problem either.

A rectifier diode has a single-cycle 60Hz surge current rating exceeding 300A and would most probably handle 300A. 8/20 $\mu$ s impulse specified in the standard, but the capability of rectifiers with lower ratings is questionable and needs to be verified. Rectifier diode surge capability will not be further addressed in this paper but clearly the rectifier must handle surge currents; the amount depends upon the protection scheme used.

In most off-line SMPS, the element which prevents excessive transient voltages from appearing across the DC bus and also bears the brunt of carrying the line to neutral transient pulse current is the filter capacitor. However, the charge delivered by the input transient and the voltage drop across the capacitor's ESL and ESR combine to develop a large overshoot voltage. This

overshoot usually shorts the power switches connected to the DC output from the rectifier system.

Providing a network to limit voltage to a predetermined maximum rather than using higher voltage power switches offers a number of advantages to the power supply designer, independent of the choice of switching transistor (i.e., bipolar or FET). For a bipolar transistor of a given die area, lowering breakdown voltage raises current gain and reduces all switching times. Reducing the breakdown voltage of a FET chip causes a marked decrease in onstate voltage-the principle determinant of power loss-because of the relationship  $r_{DS(on)}$  of  $V_B^{2.5}$ . Alternately, a smaller size power switch chip could be used to achieve the same performance while realizing a significant cost savings<sup>3</sup>.

## Conditions In An Unprotected System

Most SMPS have an input network as shown in Figure 1. The impedance is used to limit start-up inrush current without causing excessive power loss. The series impedance may be excessive power loss. The series impedance may be a thermistor or a resistor which is often shunted by a triac to reduce power loss after start-up.

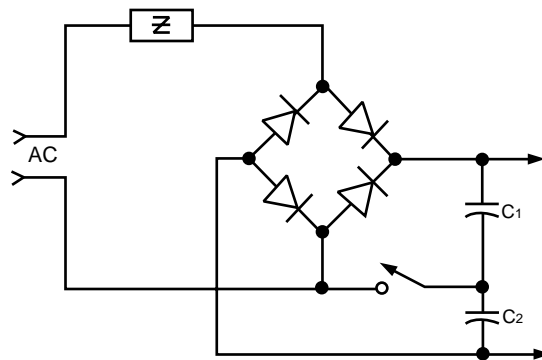

Figure 1

Basic line rectifier & filter for SMPS operating from 120/240V lines

It is not unusual to allow for a 20% tolerance on a 120/240V ac power line which puts the voltage crest at about 400 Volts. Added to the dc level is the overshoot caused by the 3000A impulse. The usual switching power supply which operates from 120/240V inputs has two capacitors as part of the voltage double arrangement. The capacitors are con-

ected in series when used on 240V. Thus, the total dc bus voltage spikes up to twice the individual capacitor transients when used on 240V.

The voltage waveform of Figure 2 reveals the presence of three components of overshoot: 1) a fast rising step caused the di/dt of the wave flowing through the capacitors ESL, 2) an in-phase component caused by the current flow through capacitor ESL, and 3) a charge placed on the capacitor. Obviously, the transient voltage can be reduced by using a large valued capacitor having low ESL and ESR. The relationship is given in Equation 1.

$$v_c = \frac{1}{C} \int i dt + iR_s + L_s \frac{di}{dt} \quad (1)$$

where

- C = input filter capacitance
- i = pulse current
- Rs = capacitor equivalent series resistance (ESR)
- L = capacitor equivalent series inductance (ES)
- di/dt = rate of rise of transient current

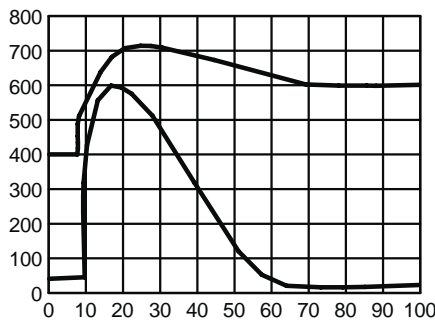

**Figure 2**

Capacitor waveform showing spike caused by current, and charge placed on capacitor

( $C_1 = C_2 = 60\mu F$ ; Upper: 10V/div; Lower: 100A/div; Time: 10µ/div)

Measured voltage transients for some different capacitors when pulsed with 500A in the circuit of Figure 1 are shown in Table 1. With a 3000A pulse, overshoots of 6 times the values shown would occur. In all cases of 240V input, the transient voltage exceeds the typical 250V surge rating of a 200 volt capacitor. Even worse, the DC bus - possibly at about 400 volts because of high line, low load condition - is now up to at least 560 volts! No wonder power switch failures occur in seemingly well designed systems.

| $C_1, C_2$ | Type                               | Input | Peak Transient Voltage | Charge Voltage |
|------------|------------------------------------|-------|------------------------|----------------|
| 540µF      | Mepco/Electra<br>319DA541T250AMA1  | 120V  | 39V                    | 30V            |
|            |                                    | 240V  | 75V                    | 58V            |
| 650µF      | Mepco/Electra<br>3120EA651T200BHA1 | 120V  | 33V                    | 23V            |
|            |                                    | 240V  | 65V                    | 46V            |
| 2100µF     | General Electric<br>44A417052M21   | 120V  | 12V                    | 7V             |
|            |                                    | 240V  | 27V                    | 16V            |

TABLE 1 – Transient performance of the circuit of Figure 1  
(Peak Pulse Current = 500A)

The spike could be clipped by a suitable TVS device but the charge voltage persists for too long and is not easily eliminated. The best solution is to minimize the amount of transient current being fed to the capacitor.

## Transient Protection Techniques

General principles of powerline transient protection have been described in a paper by Jacobus<sup>4</sup>. Almost concurrently, a specific module designed using these same principles, which meets the 3000A specification of ANSI-IEEE C62.41, was described by Roehr and Clark<sup>5</sup>. Both papers deal with providing transient protection downstream from susceptible equipment. However, in a power supply, components which must be present for rectification and filtering may be used as part of the transient suppression network.

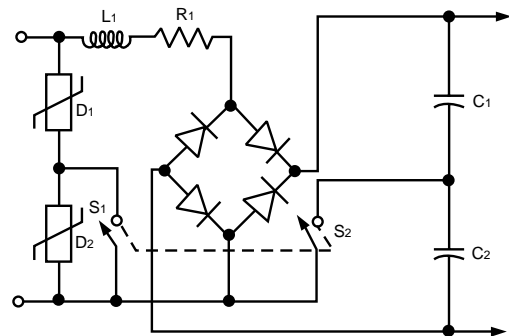

**Figure 3**

Basic circuit with MOV protection

When transient protection is used in a SMPS, it most often is nothing more than a single MOV across the line as shown in Figure 3. Table 2 shows test results taken in the circuit of Figure 3. Note that the worst transients occur in the 240V position when both switches are open. However, unless the MOV voltage is adjusted to fit the lower line voltage when used on 120V ac, ( i.e.,  $S_1$  is closed), a very large capacitor current flows. For example, with only .5 ohm impedance the 77 volt spike appears across only one capacitor; with 3000A of input current the spike would increase to 115V which could exceed the surge voltage rating of the capacitor. The 106 volt transient increases to about 150 volts when 3000A is applied, bringing the bus voltage to 550 Volts.

| $R_1 = L_1$  | Input | $S_1$  | Peak Transient Voltage | Charge Voltage | Peak Capacitor Current |
|--------------|-------|--------|------------------------|----------------|------------------------|
| 0.5Ω - 0µH   | 120V  | Open   | 77V                    | 54V            | 1080A                  |
|              |       | Closed | 24V                    | 21V            | 440A                   |
|              | 240V  | Open   | 106V                   | 78V            | 780A                   |
| 0.5Ω - 100µH | 120V  | Closed | 18V                    | 10V            | 190A                   |
|              | 240V  | Open   | 74V                    | 47V            | 440A                   |
| 1.0Ω - 100µH | 120V  | Closed | 12V                    | 7V             | 130A                   |
|              | 240V  | Open   | 53V                    | 34V            | 300A                   |

TABLE 2 – Transient performance of the circuit of Figure 3  
( $R_1 = .05\Omega$ ,  $C_1 = C_2 = 540\mu F$ , Peak Pulse Current = 2000A)

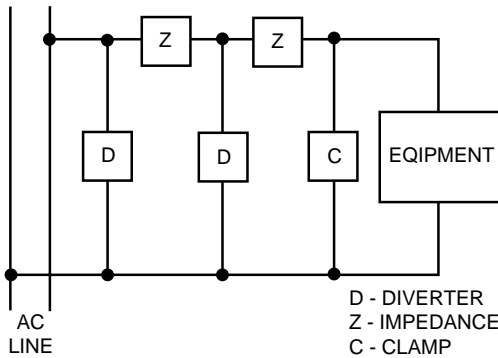

**Figure 4**

General topology for a protection network

To improve the transient suppression, the capacitor and/or the series impedance must be larger. The data in Table 2 taken with higher series impedances shows some improvement in lowering the transient levels, but the transients are still higher than desired. For very low power supplies, the circuit of Figure 3 would be satisfactory, if an appropriate series impedance and capacitor were chosen. For example, the data of Table 1 shows that the 2100 $\mu$ F capacitor allowed only 27V of overshoot with a 500A pulse. This capacitor would be satisfactory if used in Figure 3 with the 0.5 ohm-100 $\mu$ H input network.

A general topology for transient protection is shown in Figure 4 using the notations of Jacobus. The diverter devices handle high currents but do not offer a precise control of voltage; gas tubes and metal oxide varistors (MOVs) are typical elements. The clamp devices have lower impedance than the diverters but have lower energy handling capabilities. A Transient Voltage Suppressor Diode is a typical clamping device. The series impedances shown semi-isolate the various diverter and clamp stages by causing a voltage drop between them. To meet the requirements of ANSI-IEEE C62.41, Category B, and provide low output voltage clamping, the topology of Figure 4 has proven to be quite effective.

### An Integrated Rectifier/Suppressor Circuit

After some experimentation, the network of Figure 4 has been found to work quite well when the first

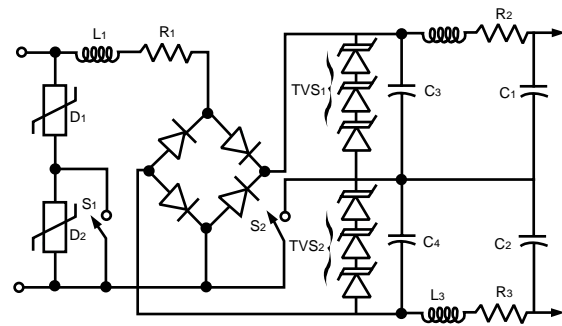

**Figure 5**

Circuit providing a high level of protection

diverter is a MOV, the first impedance is composed of the inrush current limiting resistance and an inductor, the second diverter is a silicon Transient Voltage Suppressor and capacitor network. The second impedance is a series R-L circuit, the clamping device is the filter capacitor.

**Figure 5** (patent pending) shows a practical implementation of the circuit of Figure 4, which is virtually immune to transients. The resulting T filter network also attenuates high frequency noise in both directions, thus easing EMI filter requirements. Performance is shown in Table 3 when pulsed with 2500A. The resulting 25V peak transient appearing at the output is low enough to allow the use of 450V rated transistors in the power switching section.

| Input | Peak Transient Voltage | Charge Voltage | Peak Capacitor Current |
|-------|------------------------|----------------|------------------------|
| 120V  | 9V                     | 5V             | 103A                   |
| 240V  | 25V                    | 16V            | 163A                   |

TABLE 3 – Transient performance of the circuit of Figure 5  
(Pulse Current = 2500A,  $L_1 = L_2 = L_3 = 100\text{mH}$ ,  
 $R_1 = R_2 = R_3 = 0.5\Omega$  TVS Stack; 5KP60)

### Conclusion

Only by ensuring a clean dc bus can a switching power supply be a reliable piece of equipment. Attention must be given to the lowly line rectifier and filter system to dramatically reduce line voltage transients. The circuit of Figure 5 provides a satisfactory clean dc level.

### Reference

1. "Navy Power Supply Reliability - Design and Manufacturing Guidelines," NAVMAT P4855-1, Pg 27, NAVPUBFORCEN, 5801 Tabor Ave., Philadelphia, PA 19120.
2. "IEEE Guide for Surge Voltages in Low-Voltage AC Power Circuits," IEEE Standard 587-1980, Institute of Electrical and Electronic Engineers, 345 E. 47th St., New York, NY 10017
3. Jon D. Paul And Bill Roehr, "The Use of Transient Voltage Suppressor Diodes with Power Mosfets," Official proceedings of the 9th International PCI '84 Conference, Intertec Communications, Inc. 2472 Eastman Ave., Unit 34, Ventura, CA 93003
4. N.M. Jacobus, "Designing Power Line Transient Protection Circuits," Proceedings of Powercon 11, D-4 pp. 1-11, Power Concepts, Inc., P.O. Box 5226, Ventura, CA 93003
5. William D. Roehr and O. Melville Clark, "AC Power Line Protection for an IEEE 587 Class B Environment," NASA Conference Publication 2356.