

## Chapter 9

# ANTENNA RANGE MEASUREMENTS

*Paul Wade N1BWT © 1994,1998*

Hams have been measuring antennas for many years at VHF and UHF frequencies, and have seen marked improvement in antenna designs and performance as a result. Very few serious antenna measurements have been made at 10 GHz; the additional difficulties at these frequencies are not trivial. I'll be describing a few new twists that make it more feasible.

### Overview

Antenna measurement techniques have been well described by K2RIW<sup>1</sup> and W2IMU<sup>2</sup>; the latter also appears in the ARRL Antenna Book<sup>3</sup> and is required reading for anyone considering antenna measurements.

The antenna range is set up for antenna ratiometry<sup>1</sup> so that two paths are constantly being compared, both originating from a common transmitting antenna. These two paths are called "reference" and "measurement." The reference path uses a fixed antenna that receives what should be a constant level; in reality, there are continuous small fluctuations in received signal at microwave frequencies even over a short distance like an antenna range. Using ratiometry, the reference path allows these random variations in the source power or the path loss to be corrected by an instrument that constantly compares the measurements with this reference path. The other path is for measurement. First, a standard antenna with known gain is measured and the reading recorded. Then when an unknown antenna is measured, the difference between it and the standard antenna determines the gain of the unknown antenna.

### Instrumentation

One measuring instrument commonly used for amateur antenna ranges is the venerable HP 416 Ratiometer, and crystal detectors are used to sense the RF. Basically, this technique compares the outputs of two crystal (diode) detectors. The crystal detectors are a problem — a matched pair is needed, and these are hard to find for 10 GHz. Also, diode detectors have poor sensitivity and dynamic range, so it is necessary to provide adequate power to keep the detectors operating in the square-law region where they are accurate. Another problem is drift in the old vacuum-tube HP416.

It seemed to me that a superheterodyne technique was needed. If the signal could be converted to some lower frequency, then it could be received on a better receiver. If the two channels had separate converters, then the comparison could be made at the lower frequency. Finally, if we simply switched between the two channels at the lower frequency, the output would be an AM signal — if the switching rate were audio, then an

AM receiver would have an audio output proportional to the difference between the two channels. Once the signals are combined by the switch, they may be easily amplified as needed at the lower frequency.

At 10 GHz, frequency stability is always a problem, so a normal communications receiver might be too sharp. From work with 10 GHz WBFM, I know that most signals are stable to a few hundred KHz after warmup, so a receiver with 1 MHz bandwidth might be acceptable. While I was wondering if there might be something usable in a surplus catalog, it occurred to me that I already owned a perfectly usable solid-state wideband AM receiver — an AILTECH Model 75 Precision Automatic Noise Figure Meter (PANFI), which I found at a surplus auction. Not only that, it also has a synchronous detector and an output to synchronously switch the input signal (normally the noise source). The meter reads the difference in signal level as the input is switched; in this application, instead of the difference with a noise source switched on and off, it reads the difference as it switches between the two channels, and has excellent resolution. If a signal much stronger than the noise is applied, the meter responds only to the signal rather than noise. (While checking the references for this paper, I discovered that K2RIW<sup>1</sup> had suggested the AIL Model 75 PANFI in 1976, but no one had remembered, so I had to rediscover it!)

The only problem with the PANFI is that it is calibrated to solve the noise equation:

$$F(dB) = T_{ex}(dB) - 10 \cdot \log_{10}(Y-1)$$

This requires a bit of arithmetic on a calculator or using the computer program to undo the results and find the difference in dB:

$$Y(dB) = 10 \cdot \log_{10} \left( 1 + 10^{\left( \frac{T_{ex}(dB) - F(dB)}{10} \right)} \right)$$

otherwise the indicated gains are very optimistic.

The input to most Noise Figure Meters is at 30 MHz, so I used a surplus signal generator to generate a local oscillator 30 MHz away from 10368 MHz, and used my 10 GHz transverter as the source transmitter. The signal generator provides the LO for two surplus waveguide diode mixers, but a pair of mixers like the ones in the transverter<sup>4</sup> would also be fine. (For a similar 5760 MHz antenna range, I used a dual mixer<sup>5</sup> with pipe-cap filters). Matched mixers aren't needed since they are linear mixers with wide dynamic range. I preceded each mixer with a bandpass filter, but there probably aren't many stray 10 GHz signals around. An isolator in the antenna line is useful when antennas may have high VSWR.

Everything after the mixers is at 30 MHz, so ordinary cables and components complete the setup. I included a step attenuator in the measurement side to double-check the meter readings.

The switch, shown schematically in Figure 9-1, uses a common DBM (double-balanced mixer) as an attenuator in each path. Applying a DC current through the diodes in a DBM varies the attenuation; the DBM has high loss with no DC current, and low loss with DC current applied; I measured -54 dB at 0 ma, and -2.8 dB at 20 ma. A FET and some zener diodes provide a crude switching circuit to switch the current in response to the 28 volt output from the PANFI.

Figure 9-2 shows the antenna measuring setup for 10 GHz. The reference path uses a small horn as the receiving antenna, and the source antenna is another horn. After completing all connections, the signal generator is adjusted for maximum received signal, as indicated with the PANFI switched to the noise OFF position. Then the PANFI is switched to AUTO to display the difference between the paths, which is converted to relative gain using the above equation.

## Antenna Range

The length of the antenna range is important — if it is too short, there will be significant phase difference over the aperture of the antenna being tested, resulting in low measured gain. The minimum range length to avoid this error is the Rayleigh distance:

$$\text{Rayleigh distance} = \frac{2D^2}{\lambda}$$

A few trial calculations will show that miles of range can be required for large dishes. Fortunately, the Rayleigh distance for the 25 inch dish which I wanted to measure is only 91 feet.

The antenna range is a ground-reflection range, as shown in Figure 9-3, where the range is designed to account for ground reflection and control it. One alternative would be to place the antennas high enough that ground reflection would be insignificant; however, in order to keep the reflected signal contribution from the ground to less than 0.5 db, both ends of the range would have to be 122 feet high for a range length of 91 feet. Another type of range requires the signal path to be at a 45 degree angle to the ground, so the antenna height would only be 91 feet. For most amateur work, antenna heights like these are impractical, so the ground-reflection range is used.

In order to have the phase error as low in the vertical plane as in the horizontal plane, the height of the antenna being measured must be at least **four** times its aperture diameter<sup>6</sup>, or 100 inches for the 25 inch dish. I suspect that most amateur antenna ranges have had insufficient antenna height, and consequently have had trouble measuring higher-gain

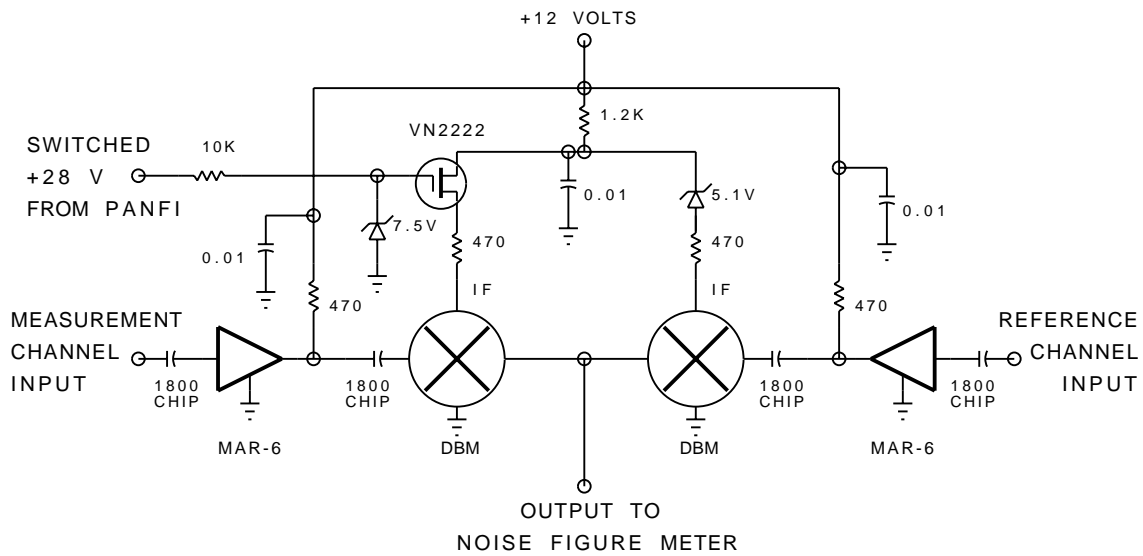

# Switch For Antenna Ratiometry

Figure 9-1

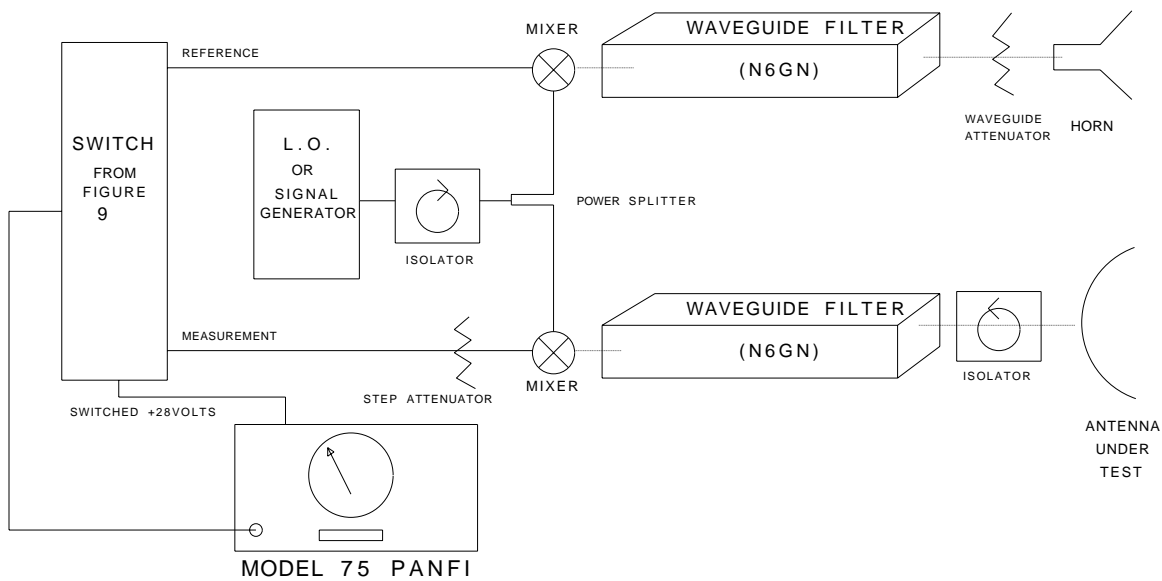

# 10 GHz Antenna Test Setup

Figure 9-2

N1BWT 1994

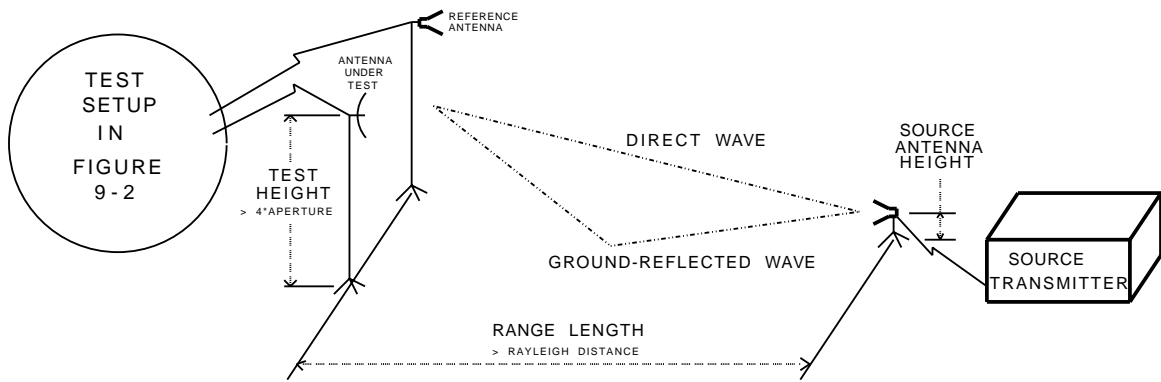

# Antenna Range With Ratiometry

Figure 9-3

N1BWT 1994

antennas accurately. My first measurements, at a height of about 4 feet, showed lower efficiency for the larger dishes. Raising the height made the measured efficiency greatest for the larger dish as you would expect, since the feedhorn blocks a smaller percentage of the aperture.

The received energy should be at a maximum at the height of the antenna being measured. For a ground-reflection antenna range, this is controlled by the height of the source antenna:

$$\text{Height}_{\text{source}} = \frac{\lambda \cdot \text{Range length}}{4 \cdot \text{Height}_{\text{measurement}}}$$

which works out to about 3 inches for the 91 foot long range with the receiving antenna 100 inches high. Therefore, by adjusting the reference and measurement antennas to over 8 feet high (easily done on the back of a pickup truck or a porch) and placing the height of the source and antenna around 3 inches, good, reliable, and accurate results may be obtained (see Table 9-1). Figure 9-4 shows how we stacked two tables under the tripod to get the measurement antenna ten feet high, so that we could accurately measure antennas up to 30 inches in diameter.

## Gain Standard

In order to measure meaningful antenna gains, an antenna with known gain is required. Recall that all measurements are relative to a known standard. A dipole is useless as a standard — its broad pattern receives so many stray reflections that repeatable readings are nearly impossible, and its gain is much lower than a 30+ dB dish that equipment accuracy is a problem; few instruments are accurate over a 30 dB (1000:1 power ratio) range.

What is required is an antenna with a known gain, preferably gain of the same order of magnitude as the antennas to be measured. At microwave frequencies, the gain of a horn antenna can be calculated quite accurately from the physical dimensions. The algorithm used in the **HDLANT** program will be accurate within about 0.2 dB if good construction techniques are used.

For even better accuracy, several companies make standard gain horns with good calibration data. For 10 GHz, a standard gain horn was lent to me by KM3T — he was lucky enough to find one surplus. Mr. John Berry of Scientific-Atlanta was kind enough to provide the gain calibration curve.

## Range Measurements

Once the antenna range is designed and set up, it must be checked out before making actual measurements. This is best done with an antenna with a fairly broad pattern, like a

Figure 9-4





medium-sized horn, as the test antenna. First, the attenuators are adjusted for a convenient meter reading. Then the field uniformity is probed by moving the test antenna horizontally and vertically around the intended measurement point. In Figure 9-5, I am probing the field with a horn while standing on top of the stacked tables shown in Figure 9-4. The indicated gain should peak at the center and should not vary significantly over an area larger than any antenna to be tested; the variation should be less than one dB. At this point, the height of the source antenna usually needs to be adjusted to get the vertical peak at the intended receiving height. Finally, the test antenna is held stationary and calibrated attenuation steps are added in the test path to make sure the indicated gain (after correction if using a PANFI) changes by the amount of attenuation added. With a Ratiometer, the attenuation must be added at the microwave frequency, but a PANFI system like Figure 9-2 with a linear mixer allows the use of an IF attenuator; step attenuators are much easier to find for 30 MHz than for 10 GHz.

Now the range is ready to make measurements. The standard gain antenna is inserted as the test antenna, aimed for maximum indication, and the attenuators adjusted for a meter reading that will keep expected gains within the range of the meter. All gain measurements will be the difference from this standard reading added to the gain of the standard gain antenna. The standard gain antenna is replaced by an antenna to be tested, the new antenna aimed for maximum gain, and its indicated gain recorded. The difference between this indicated gain and the standard reading, after correction, added to the known gain of the standard gain antenna, is the gain of the test antenna. The reading with the standard gain antenna should be checked frequently to correct for instrumentation drift; ratiometry with the reference antenna corrects for other sources of drift.

## **Measurement Results**

The first 10 GHz antenna range I set up in my yard was 102 feet long, more than the Rayleigh distance, with the equipment described above. The received field was probed for uniformity, and height of the source antenna adjusted for a flat field at the required height. Then I was able to start measurements, using a standard gain horn for comparison.

In order to compare different feeds for parabolic dishes, I wanted to measure the gain of several of them with the same reflector, to find the performance as complete antennas. I made a mechanism, shown in Figure 9-6, from an old slotted line carriage and some photographic hardware so that the feed could be moved in three dimensions with fine control of adjustment, so that each adjustment could be peaked for maximum gain.

Measurement results from several sessions are shown in Table 9-1.



Figure 9-5

Figure 9-6

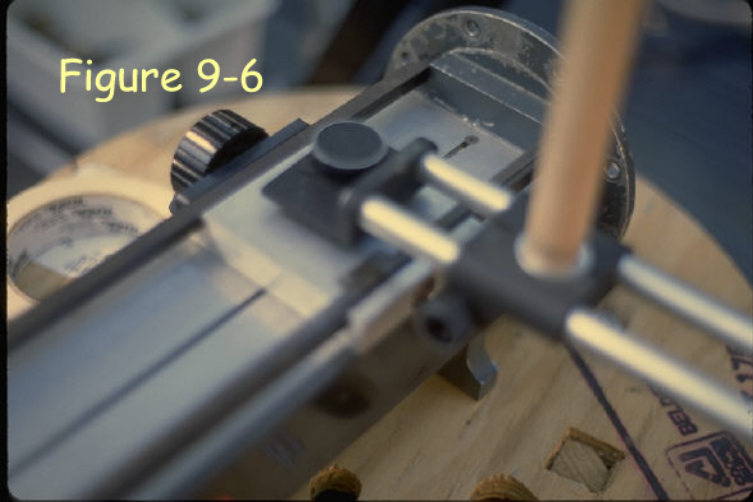

# SUMMARY OF 10.368 GHz ANTENNA RANGE MEASUREMENTS

Table 9-1:

5/14/94, 12/18/93, 9/15/94, 7/6/95

ANTENNA	Focal Distance inches	Gain dBi	Efficiency
Standard Gain Horn, Scientific-Atlanta Model 12-8.2 (22.5 dBi calculated)		22.45	43%
WB1FKF homemade horn (copy of above horn)		22.05	
Gunnplexer Horn (17.45 dBi calculated)		17.5	57%
+ 6" lens	~8	20.9	45%
+ 12" lens	~21	27.4	50%
Surplus horn (19.4 dBi calculated)		19.6	67%
WIRIL loop Yagi		16.0	
22" dish, f/D=0.39, surplus, feed = 11 GHz Superfeed*: unmodified feed	8.25	33.1	55%
with feedline to reflector		32.2	45%
modified feed		32.9	53%
25" dish, f/D = .45, Satellite City, with the following feeds:			
11 GHz Superfeed (Chaparral)	10.875	34.4	58%
11 GHz Superfeed, modified flush	11.187	34.6	61%
Clavin feed (1974)	11.125	34.1	54%
Rectangular Horn, E=0.9", H=1.38"	10.625	33.7	49%
Rectangular Horn, E=1.14", H=0.9"	10.625	32.9	41%
WR-90 to coax Transition	11.0	32.7	39%
WA1MBA log periodic	10.94	32.4	37%
G4ALN "Penny" feed	10.375	33.0	41.5%
18" dish, f/D = 0.42, Satellite City, with the following feeds:			
11 GHz Superfeed (Chaparral)	7.75	31.7	60%
Clavin feed (1974)	7.875	31.2	53%
Rectangular Horn, E=0.9", H=1.38"		31.5	57%
WR-90 to coax Transition, rectangular flange		30.2	42%
WR-90 to coax Transition, round flange, o.d. = 2.15"		30.2	42%
Cylindrical horn with slotted choke ring	7.875	~28 *	~26% *
WA3RMX Triband feed		~17 *	
18" offset dish, RCA DSS steel, with the following feeds:			
Rectangular Horn, E=31.2mm, H=41.1mm, Len =20mm	11	32.0	63.5
Rectangular Horn, E=31.2mm, H=41.1mm, Len =20mm	11.25	31.0	50
Rectangular Horn, E=31.2mm, H=41.1mm,		31.5	57

Len=10mm Rect. Horn, surplus, E=30.1mm, H=45.2mm, L = 42mm	11	31.8	61
24" dish (WB1FKF), with the following feeds: 11 GHz Superfeed with Styrofoam housing		34.4	62
WA1MBA log periodic		28	14
24" offset dish, plastic, with the following feed: Rectangular Horn, E=31.2mm, H=41.1mm, Len=20mm.	14.75	34.3	61
30" dish, f/D = .45, (lighting reflector), with the following feeds: 11 GHz Superfeed*, modified flush	13.5	36.4	64
24" Prodelin dish antenna: feed is rectangular horn fed by WR-90 waveguide "shepherd's crook		33.6	52%

---

RANGE LENGTH = 102 TO 150 feet.  $2D^2/\lambda = 91$  feet. Test height 8 to 10 feet.

FOCAL DISTANCE SENSITIVITY: each feed was adjusted for max gain.

Gain was down 1 dB about 1/4" either way from peak.

NOTES: \* These feeds were not positioned accurately - more gain possible.

MEASURED BY: N1BWT, W1RIL, WB1FKF, KB1VC, N1BAQ

## Discussion

The first thing that became apparent is that all adjustments on a dish are critical. In the field, looking at a tiny S-meter, it doesn't seem so difficult to point a dish with a beamwidth of only ~3 degrees. The PANFI, however, has a large meter with one dB expanded out to nearly an inch. On this meter, even tiny adjustments have obvious effects, demonstrating how aiming dish is a little touchy.

The most critical dimension is the focal length — the axial distance from the feed to the center of the dish. A change of 1/4 inch, or about a quarter-wavelength, changed the gain by a dB or more. The critical focal length suggests that it is crucial to have the phase center of the feed exactly at the focus of the reflector. Since the phase center is rarely specified for a feedhorn, we must determine it empirically, by finding the maximum gain on a reflector with known focal length, which we can estimate from templates for various  $f/D$ . Thus we can estimate the phase centers for all the feeds in Table 9-1. For the Chaparral style feed horns, we can deduce some further information. Several different ones were measured, with two different dimensions, and with adjustable choke rings. Regardless of where the choke ring was set, maximum gain occurred with the choke ring the same distance from the reflector. This implies that the phase center is controlled by the position of the choke ring, not the central waveguide. The version designed for 11 GHz TVRO, with gain shown in Table 9-1, has an apparent phase center in front of the

choke ring, while a larger one, dimensioned for 10 GHz, has the apparent phase center behind the choke ring (inside the ring), and provides gain similar to the smaller one.

As for efficiency, none of the dish measurements in Table 9-1 exceeds 60%, and it is obviously easy to get efficiencies less than 50%. This suggests to me that the 55% quoted in the books is far from typical, and careful design and measurement is needed to reach or exceed it. As illustrated in Chapter 4, dishes with small  $f/D$  ( $< 0.3$ ) may be very difficult to feed efficiently.

Several of the dish measurements in Table 9-1 were made with a coax-to-waveguide transition as a feed — the open-ended waveguide flange acts as a small horn. This is not an optimum feed, as shown by the low efficiency, but it is one that is readily available for comparisons. If the feed for your dish does not perform significantly better than a plain waveguide flange, it can certainly stand improvement.

Measured horn and lens efficiencies are comparable to dish efficiencies, so we can conclude that all three types of antennas can provide the same gain for the same aperture area. This leaves us free to choose the type of antenna best suited to the application.

Efficiency calculation is also important as a sanity check. In recent years, I have seen gain measurement results from various VHF conferences where some of the efficiencies calculated to over 150%. Only TV antenna manufacturers are able to achieve these miraculous gains! On the other hand, at other conferences, all the antennas had gains which equated to efficiencies less than 25%; it is unlikely that all the entrants were incompetent. In both cases, a simple efficiency calculation would have provided a sanity check to show that there was some problem with the antenna range or instrumentation.

## **Feed pattern measurement**

Antenna gain measurements on large antennas like dishes are difficult and require a large antenna range. Pattern measurements are even more difficult, since sidelobes may be more than 20 dB down, so even small reflections can distort the pattern. On the other hand, the small aperture of a feed horn requires much smaller distance for far-field measurements. Most of these feeds are 2 wavelengths or less in diameter, so an antenna range 2 feet long at 10 GHz or 10 feet long at 1296 MHz would be fine. If all reflecting obstacles can be four times as far away as the range length (8 feet at 10 GHz), then all reflections would be more than 18 dB down.

The broad pattern of feed horns requires far less dynamic range, especially since we are most interested in the shape of the main lobe. Only a simple power detector is required, since we will compare readings to the maximum power. The test procedure is to take a reading with the feed aimed at the source antenna, then rotate the feed in increments of 10 or 20 degrees and note the change in detected power. An accurate calculation requires patterns in both **E**- and **H**-planes, so next rotate the polarization of both the feed and source antennas 90 degrees and take another set of readings for the other plane.

A few data points, until the amplitude is at least 15 dB down, are adequate to find the shape of the efficiency curve and estimate the  $f/D$  for best efficiency, but the sidelobes and backlobes are needed to make reasonably accurate efficiency calculations. If you are unable to get good readings for the backlobes, use 20 dB as a first approximation. Enter the data points in a data file in the same format as the files for the published feeds, and run the **FEEDPATT** program described in Chapter 11.

One problem with a very short range is that small changes in range length will change the path loss. Thus, it is important to make sure that the distance from the antenna to the source antenna does not change as it is rotated. I check the length at each rotation angle.

## Measured feed patterns

I couldn't suggest a measurement technique without trying it, and I had a few interesting feeds for which I could not find published data, so I set up a 24 inch antenna range and made some measurement. The source was a low power transverter, since the path loss (see Chapter 1) is much smaller than for a large antenna range. For the detector, I used the sun noise measurement equipment described in Chapter 10 with lots of attenuators, including a step attenuator to increase the dynamic range.

I measured a total of four 10 GHz feeds:

- Chaparral "11 GHz Superfeed."
- G4ALN "Penny" feed
- Chaparral 11 GHz feedhorn for offset dishes
- small rectangular horn - used to feed a DSS offset dish

Descriptions of these feeds and the measured data were given in Chapter 6.

These comparisons of the efficiencies previously measured by gain and sun noise techniques with the efficiencies calculated from the measured feed patterns is a good verification of the **FEEDPATT** computer program.

## Phase Center Measurement

For antennas used as feeds for dishes and lenses, knowing the location of the phase center is useful — the phase center should be located at the focal point. Unfortunately, measurement of phase center requires that we be able to measure phase, which is extremely difficult with affordable instrumentation. An Automatic Network Analyzer could be used to make a terrific antenna range, if I could just borrow one for a weekend.

However, I will describe how the phase center may be determined, hoping that someone will be able to make the measurements someday. The required measurement is to measure the phase  $\phi$  over the pattern rotation angle  $\theta$  in addition to the usual amplitude pattern, at least over the interesting part of the pattern which would illuminate a dish, down to the -10 dB or -15 dB points. Unless we were very lucky and rotated the antenna around the phase center, the measured phase  $\phi$  will vary with rotation angle  $\theta$ . From this variation, we can calculate<sup>xx</sup> the phase center using:

$$d = \frac{\Delta\phi \cdot \lambda}{2\pi(1 - \cos\theta)}$$

where  $\Delta\phi$  is the change in measured phase from the phase on-axis, and  $d$  is the displacement of the phase center toward the source; i.e., if  $d$  is positive, then the phase center is closer to the test range source, and a negative  $d$  is farther away from the source. The displacement is from the point about which the antenna was rotated, so clearly it is important to rotate on a stable mechanism.

The calculated displacement will probably be different for each measured rotation angle. Plotting the results on a graph and doing some curve fitting will probably give a good approximation; it will also show any big discrepancies which might result from the indicated phase going past 360° to zero, so that the  $\Delta\phi$  can be corrected.

## Summary

Amateur antenna gain measurement at 10 GHz with good results has been demonstrated using ratiometry, and a Noise Figure Meter is a good solid-state replacement for a vacuum-tube Ratiometer. Antenna gain measurements are valuable for making critical adjustments and for verifying that an antenna is providing the performance expected. Better antenna gain measurements should bring the same improvement to amateur microwave antennas that years of Antenna Measuring Contests have brought to VHF and UHF antennas.

A much smaller antenna range may be used to measure patterns of feeds for dishes, and the **FEEDPATT** program used to predict dish performance. This is particularly useful when the dish is too large to be measured on a practical antenna range.



## **References**

1. R.T. Knadle, K2RIW, "UHF Antenna Ratiometry," *QST*, Feb. 1976, pp. 22-25.
2. D. Turrin, W2IMU, "Antenna Performance Measurements," *QST*, Nov. 1974, pp. 35-41.
3. *The ARRL Antenna Book*, ARRL, 1991, pages 27-43 to 27-48.
4. P. Wade, N1BWT, "Building Blocks for a 10 GHz Transverter," *Proceedings of the 19th Eastern VHF/UHF Conference*, ARRL, May 1993, pp. 75-85.
5. P. Wade, N1BWT, "Mixers, etc., for 5760 MHz," *Proceedings of Microwave Update '92*, ARRL, 1992, pp. 71-79.
6. E.S. Gillespie, "Measurement of Antenna Radiation Characteristics," in *Antenna Handbook: theory, applications, and design*, Y.T. Lo and S.W. Lee, editors, Van Nostrand Reinhold, 1988, page 32-22.
7. G. A. Evans, *Antenna Measurement Techniques*, Artech, 1990, p. 82.