

PHASE-LOCKED SOURCES FOR LMDS AND MVDS APPLICATIONS

Currently, 28 and 42 GHz mm-wave systems are being offered for wireless local multipoint distribution systems (LMDS) and multipoint video distribution systems (MVDS). Systems operating at 31 GHz have also been proposed for these applications. These systems offer more than just television entertainment, they also have the capability to provide high speed data and video telephone communications. Both the 28 and 42 GHz systems are two-way systems that offer good performance compared to the low frequency, one-way systems.

For the most part, LOs used in the frequency-conversion sections of these systems have been phase-locked dielectric resonator oscillators (DRO). However, recent advances in yttrium iron garnet (YIG) oscillator technology have produced very low noise sources that offer good performance advantages when ruggedized for microphonics and environmental conditions. Currently, systems with YIG-based phase-lock loop oscillators (PLLO) are using doubler schemes to achieve the required LMDS and MVDS output frequencies.

Typical phase-locked YIG sources have single-sideband (SSB) phase noise performance of -120 dBc/Hz at 100 kHz offset and -145 dBc/Hz at 1 MHz offset in the 13 to 15 GHz frequency range, and offer 5 to 10 dB of phase noise improvement over other available LOs. Actually, this low phase noise is the YIG oscillator's free-running noise outside the phase-lock loop bandwidth, providing significant system design advantages.

The MLPE series phase-locked oscillators provide these improved phase noise levels using either a bipolar or FET-based YIG oscillator. **Figure 1** shows the typical SSB phase noise of a FET-based PLLO at 13 GHz and the typical SSB phase noise of a Bipolar-based PLLO at 13.58 GHz. The noise performance of both oscillators is within 3 dB of each other at 100 kHz offset, meeting the target requirement of -120 dBc/Hz easily.

The heart of the MLPE series PLLOs is a low noise permanent magnet oscillator (PMO). The benefits of using a PMO configuration include the inherent low noise performance, low prime power coil, proven microphonic performance and small size (typically 0.5 cubic inches). In overcoming the stringent microphonic and environmental operating conditions, special assembly and test processes had to be developed. Stress-relieving techniques are employed for all assemblies starting at the subassembly level, and proprietary ruggedization techniques are used for the magnet assembly. The final assemblies are also stress relieved and tested for microphonic susceptibility.

Figure 3 shows a simplified block diagram for a phase-locked YIG source at 14 GHz, which is typical of units covering the 13 to 15 GHz range. In this example, the YIG oscillator is tuned to 14 GHz ± 5 MHz. When a high level

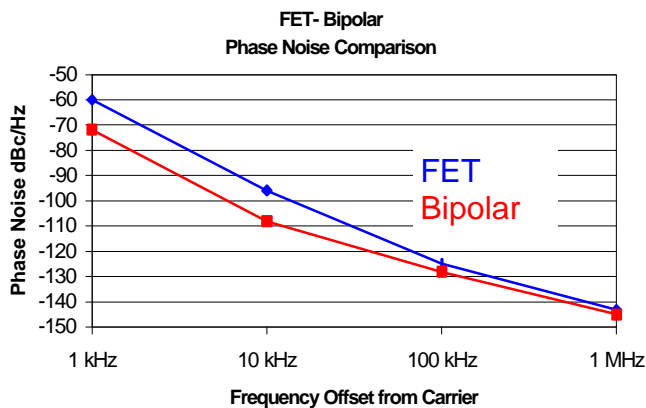

Figure 1

PHASE LOCKED OSCILLATORS

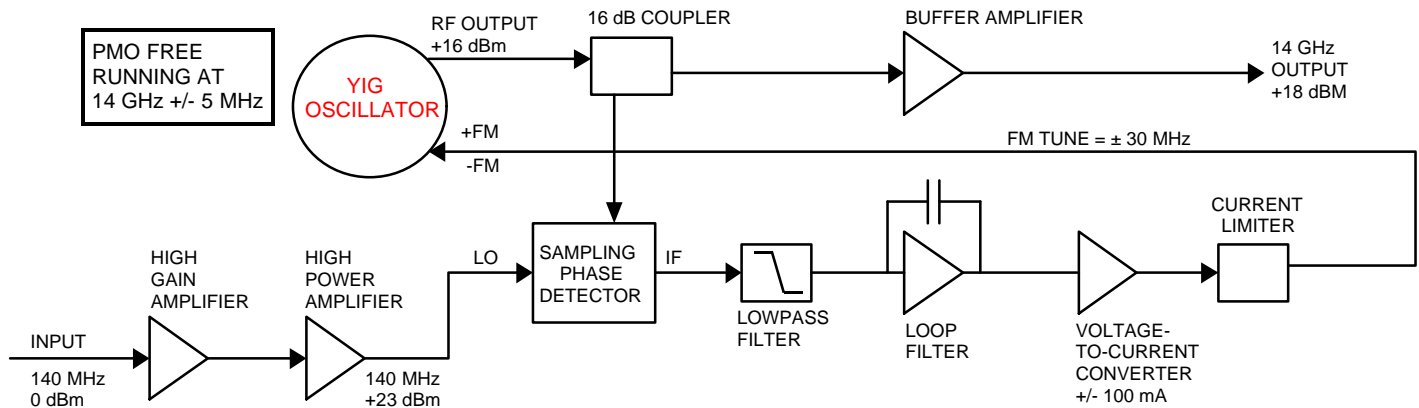

Figure 3: The phase-locked YIG source's simplified block diagram

140 MHz signal (typically a low noise crystal oscillator) is applied to the reference input, the step recovery diode (SRD) in the sampling phase detector produces a frequency comb with elements spaced 140 MHz apart. The 14 GHz signal (RF) from the YIG oscillator is mixed with the 100th tooth of the 140 MHz comb (LO) from the SRD, producing an IF signal that is passed through a lowpass filter and converted to a correction current applied to the YIG oscillator's FM coil. This process phase locks the YIG oscillator to the 140 MHz reference input.

The phase noise degradation of the 14 GHz signal is equal to $20\log(N)$, where $N = 100$ in this case. This noise degradation represents a 40 dB increase over the noise level of the reference signal inside the phase-lock loop bandwidth. Thus, if the reference oscillator had a -160 dBc/Hz phase noise level at 10 kHz offset, the 14 GHz oscillator output would produce a -120 dBc/Hz noise level at the same 10 kHz offset. Outside the loop bandwidth, the 14 GHz signal takes on the phase noise characteristics of the free-running YIG oscillator (typically -145 dBc/Hz at 1 MHz offset).

One advantage of using a permanent magnet YIG oscillator is that the magnet does not require a tuning current. The 14 GHz PMO uses a strong permanent magnetic field to tune the oscillator's frequency. A typical MLPE PLLO uses < 450 mA of total power supply current.

The MLPE series PLLOs feature 14 to 15 dBm ± 2 dB of output power over a 0° to 70°C operating temperature range. Spurious and harmonic outputs are -80 and -20 dBc, respectively. The oscillators accept reference inputs in the 130 to 156 MHz range at 0 dBm ± 3 dB, and operate from $+12$ V DC at 400 mA and -12 V DC at 100 mA. An alarm output is provided to indicate loss of lock.

The MLPE series PLLOs have been designed in a package equivalent to typical phase-locked DROs. The standard size for a YIG-based PLLO is 2.25" X 2.25" X 0.68", with the unit's mounting holes in the same location as a phase-locked DRO. The RF output and reference input connectors are field-replaceable SMA-F. **Micro Lambda, Inc. 48041 Fremont Blvd., Fremont, CA 94538 (510) 770-9221 FAX: (510) 770-9213**