



Jochen Jirmann, DB 1 NV

A Spectrum Analyser for the Radio Amateur

Spectrum analysers enjoy a special place in the hearts and minds of amateur radio constructors. For one thing, they are able to display immediately the full output spectrum of a transmitter and the relative amplitudes. The other awe provoking thought which springs to mind is their enormous cost – now, almost as much as a small house. The possession of a spectrum analyser must surely be, for most amateur constructors, completely out of the question. Also, a perusal of a commercial analyser's specifications are enough to convince many that the amateur construction of such an instrument is fraught with unsurmountable difficulties. But, of course, one should'n't despair quite so easily because, for example, what radio amateur requires facilities such as a 10 Hz resolution at 20 GHz? In other words, if the facilities offered by a commercial spectrum analyser were pruned down to those required by the radio amateur then it is indeed entirely feasible to undertake the home construction of such an instrument.

The following article is intended to excite the reader to experiment with the project, those who require a "watertight" construction article complete with PCB layout patterns and a guarantee of sure-fire results will be disappointed. It must be appreciated that the detailed description of such a project would

occupy all the pages of VHF COMMUNICATIONS for the whole year. The author is, however, prepared to give advice to various project-groups which might be formed.

In the almost continuously occupied frequency bands of today, a smooth succession of stations carrying various services can only be maximized within a given band if these stations observe the minimum demands concerning the radiation of extraneous energy. Even modern high-level receivers employing ring mixers fed with a high oscillator power in the region of 200 mW can, when poorly designed/constructed, cause a lot of trouble. Whilst one can be reasonably assured that a transceiver of a propriety manufacturer will satisfy at least the minimum requirements of the radio regulatory authority, it will not be so certain that a home-constructed piece of equipment will offer the same freedom from spurious and unauthorized radiation. This can only be ascertained, in most cases, by a visit to the post office stand at a large ham-fest where the item may be subjected to the statutory tests.

If a complete survey of the harmonic and intermodulation content of a transmitter or oscillator is required then the spectrum analyser is the correct instrument to do it. It represents an



electronically periodically tunable superheterodyne receiver which is able to display the level of the signal-under-test together with the relative levels of its modulation and spurious signals. A commercial instrument would cover, typically, a range from a few Hz right up to twenty GHz (with supplementary mixers 325 GHz) and cost from 20 to 300 thousand DM. Not many amateurs could afford to buy a new one and those offered for sale at flea-markets are ageing, obsolete examples which have a restricted dynamic range. Those not having the luck to find a good second-hand analyser might consider the idea of making one for themselves.

In 1976, DL 8 ZX published one of the first homebrew concepts which covered a frequency range from 0 to 60 MHz and from 120 to 180 MHz. A cable TV tuner was introduced in 1980 which was used as the first down-converter. The present article will consider how a spectrum analyser with usable specifications can be realized with a tenable degree of constructional complexity.

1. CONCEPT

Before a circuit concept may be considered, it is necessary to define the facilities the instrument should offer in order that a sense of proportion is acquired and that no subliminal objectives should be striven for. A few minimal demands will therefore be set down as follows: –

Frequency range: 0 – 500 MHz and eventually 500 – 1500 MHz. This covers all the chief activities up to 70 cm with the basic unit. The additional down-converter covers the 23 cm band and all the important signal processing frequencies for the production of signals in the microwave bands.

Dynamic range: At least 60 dB. A harmonic and intermodulation capability of 60 dB is perfectly sufficient and is, indeed, better than that attained by some lower-priced commercial instruments. Valved power amplifiers, without output filtering, achieve only up to 40 dB harmonic and inter-

modulation specification and 2 m and 70 cm transistor PAs are not much better.

Resolution (analyser bandwidth): Switchable from 200 – 500 kHz for survey measurements and down to 1 kHz in order to identify third-order intermod. products and neighbouring synthesizer channels.

Stability: Short-term stability must be better than the smallest resolution bandwidth i.e. 1 kHz. Long-term stability: better than ± 3 dB both over the whole frequency and the whole dynamic range.

Sensitivity ($10 \text{ dB s} = \text{N/N}$): better than -100 dBm i.e. $12 \mu\text{V}/50 \Omega$ at the smallest bandwidth.

LO spectral purity: Noise sidebands ± 25 kHz from carrier should be lower than -60 dB in order to preserve the validity of the dynamic range specification.

The circuit should use easily obtainable components and require the minimum of tuning adjustment even if this might mean increasing the circuit complexity somewhat. Otherwise, the circuit might require the services of another spectrum analyser to align it – and that doesn't help anyone. A few modules will now be regarded a little more closely in order to evolve the various realization possibilities and at the same time identify a few potential trouble-spots in order to circumvent them. The most important step in this direction is the determination of the local oscillator and IF frequency plan.

1.1. Frequency Plan

The spectrum analyser is a periodically, tunable receiver with an extremely large frequency range encompassing two or three decades. Signals within this frequency range must be converted into a fixed intermediate frequency in order that the selection and amplitude processing can be carried out. Every superhet. receiver has a principal spurious receive frequency, known as the image-frequency whose effects are normally rendered harmless, in a conventional receiver, by the preselector filter circuits. It goes without saying that this technique is not suitable for this application where the tuning range is completely continuous. The only solution therefore is to

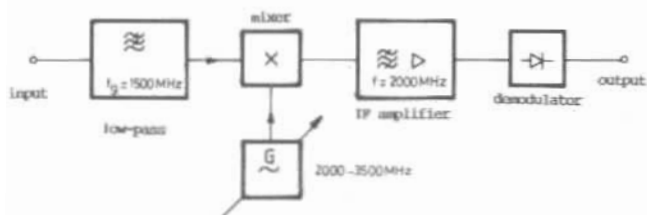

Fig. 1.1:
Block diagram of
0 - 1500 MHz spectrum
analyser

make the IF, as with many modern general-purpose receivers, lie above the highest receiver input frequency. The image frequency can then be identified and filtered out of the receiver input by means of a simple low-pass filter. The image frequency can also be used as a second input frequency and this is quite normal now in commercial instruments.

By using harmonics of the local oscillator for use in the mixer, further receive ranges can be arranged. It has to be borne in mind, however, that the conversion loss of the mixer is much greater at harmonic LO inputs. This is the usual practice for commercial analysers which use up to the 20th LO harmonic in order to provide coverage in the millimeter wave range.

The most obvious frequency plan for a receive range of 0 to 1500 MHz would be to locate the IF at above 1500 MHz, e.g. 2 GHz, and the oscillator tuning from 2.0 to 3.5 GHz as shown in fig. 1.1. The received input range is then fully covered and

the image frequency can easily be eliminated with a simple low-pass input filter.

The snag with this solution is that a tuned oscillator range of 2.0 to 3.5 GHz would be required, which with amateur means, is hardly feasible, moreover, a mixer for these frequencies is relatively expensive.

The IF at 2 GHz presents no real problem but it should be borne in mind that a second conversion to a more amenable frequency for bandwidth and signal processing e.g. 10.7 MHz or 21.4 MHz will have to be carried out. Thus the receiver input range can remain unbroken with a high image rejection and the signal processing can be effectively carried out, all by means of the double-superheterodyne technique. If an IF of 500 MHz is chosen, two ranges of input frequency become available, 0 to 500 MHz and 1000 to 1500 MHz with the local oscillator tuning between 500 and 1000 MHz. The receive ranges may be separated with selectable high and low-pass filters. Diode

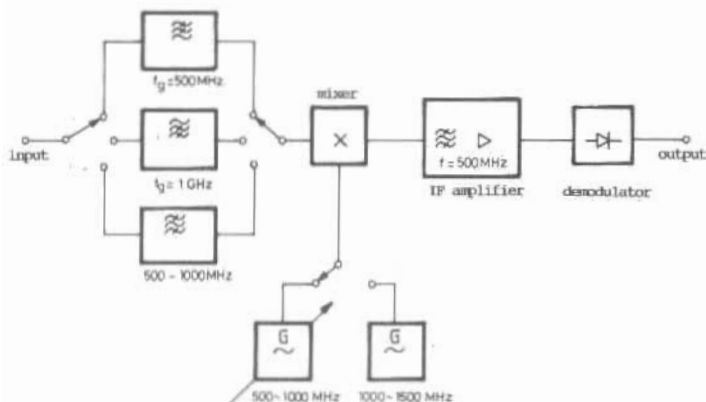

Fig. 1.2:
A spectrum analyser
tunable in 500 MHz bands

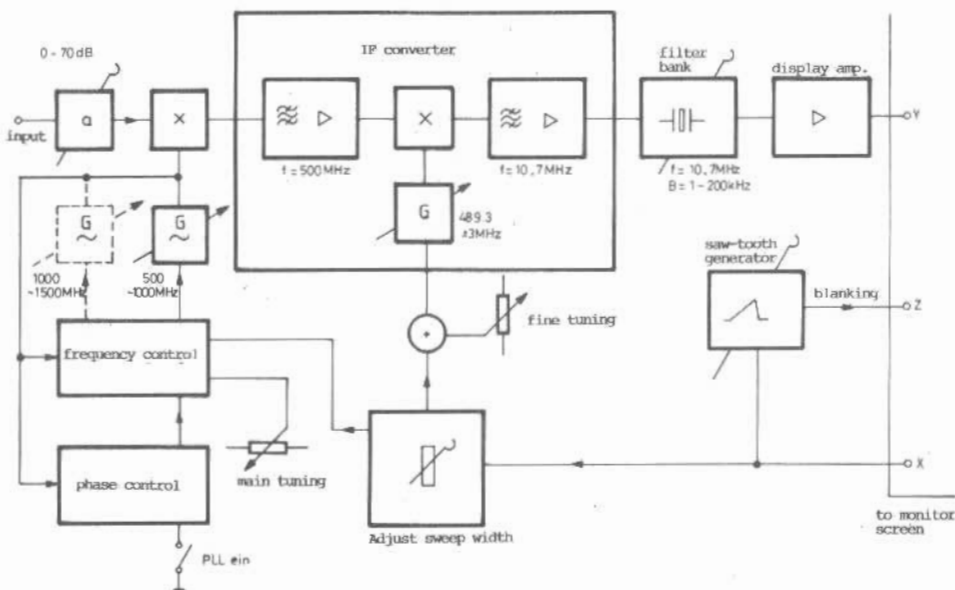

Fig. 1.3: Block diagram of a practical spectrum analyser

tuned VCO's are easily realized at these frequencies and the translation of 500 to 10.7 MHz may be carried out in a single step. The disadvantage of the missing input spectrum range of 500 to 1000 MHz may be overcome by employing an additional 1st LO covering 1000 to 1500 MHz. This further extends the received input range possibility from 1500 to 2000 MHz. The block diagram for this arrangement is shown in fig. 1.2.

A third possibility is represented by an IF of 1 GHz but this brings a rather more unfavourable receive range than the above cases as can easily be appreciated.

After settling, in general, that a frequency plan such as that of fig. 1.2, is in fact tenable, the block diagram of the spectrum analyser can be fleshed-out a little. This is shown in fig. 1.3, which includes the following modules:

- The input mixer: A proprietary mixer such as the SRA-220 may be employed here.
- The voltage-controlled-oscillator, (VCO) con-

trolled by a PLL circuit for adequate frequency stability when using the higher resolutions.

- The IF 2nd mixer down-converting from 500 MHz to 10.7 MHz or 21.4 MHz.
- The main analyser filtering in the 2nd IF.
- The logarithmic display amplifier.
- The control circuits for the tuning and control of the oscillator.

The 2nd mixer, which brings the first IF down to a standard 10.7 MHz or 21.4 MHz, will be considered first.

2. THE 2ND MIXER

Following the plan as laid out in the previous chapter, the 500 MHz 1st IF signals are produced by received inputs being mixed with a first local

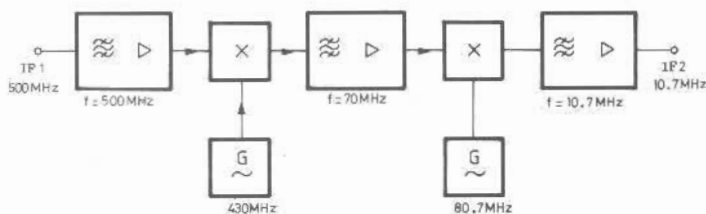

Fig. 2.1:
An IF converter with
two conversions

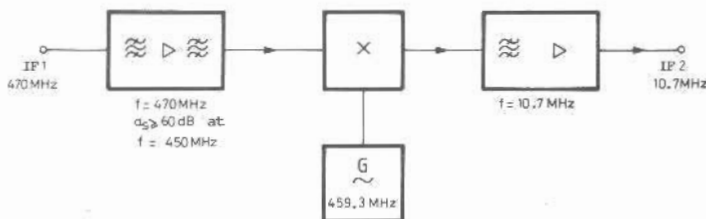

Fig. 2.2:
An IF converter with
a single conversion

oscillator with a tunable range of 500 MHz to 1000 MHz. The conversion of the signals to 10.7 MHz must be carried out with an image frequency suppression of at least 60 dB in order to reduce spurious inputs to the following circuits. In a normal receiver, this would be accomplished using a further IF at about 70 MHz in order to reduce the demands upon the mixer input filter for this level of image suppression. This scheme is shown in **fig. 2.1**.

The disadvantage of this technique is the greatly increased possibility of producing spurious signals from the total of three instrument LOs which would have to be employed. The author has therefore decided upon the direct conversion of 1st IF signals at 500 MHz to an IF of 10.7 MHz and this is outlined in the scheme of **fig. 2.2**. It will be observed that the image frequency is at 21.4 MHz removed from the 500 MHz input frequency and the filter must satisfy the 60 dB image suppression requirement.

This order of suppression can only be achieved with pot resonators or with helix resonators – the latter, on account of its smaller form, is to be preferred. The mini helix filter 10H3 can be ob-

tained from Telequarz, for about DM 20,-. This is tunable from 440 MHz to 500 MHz and at 450 MHz it has a selectivity of some 40 dB. Cascading two of these filters ensures that the image specification of 60 dB suppression will easily be achieved. This entails fixing the first IF not at exactly 500 MHz but at 460 to 470 MHz in order to avoid direct interference from any local channel 21 to 25 television transmitter.

The satellite television receivers use a surface wave filter which has a suitable mid-frequency of 479.5 MHz but the insertion loss at 20 dB is far too high. Also its bandwidth is around 35 MHz with a selectivity of 50 dB. The latter specification would make two in cascade necessary. The author has therefore decided for the helical filter. The detailed schematic of **fig. 2.3** shows two such filters separated by an amplifying BFT 66 transistor. The net gain of this combination is 5 dB with a bandwidth of 6 MHz.

A ring mixer follows the second helical filter which supplies the second IF at 10.7 MHz. The 2nd local oscillator consists of a BF 247 Colpitts oscillator circuit working at 10.7 MHz below the first IF and supplying 10 mW output power. The os-

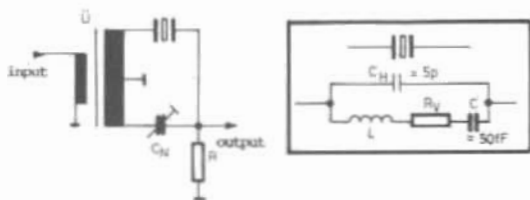

Fig. 3.1:
Basic circuit of a crystal filter

oscillator frequency can be shifted a few MHz by means of a varicap diode.

It has been proved that small swept bandwidths, i.e. under 5 MHz, are better accomplished by fixing the 1st LO with a crystal and sweeping the frequency of the 2nd LO. The analyser fine-tuning between the synthesizer step frequencies can also be done here.

The ring-mixer IF output is terminated with a diplexer but it is not strictly necessary. A BF 246 transistor matching stage amplifies the signal by 10 dB. The signal is then filtered by a 10.7 MHz

bandpass circuit followed by a further 30 dB of amplification in a MOSFET (e.g. 40673) amplifying stage. The gain of the converter can be controlled downwards from 30 dB by the application of a bias on the gate 2 of this MOSFET stage. The 10.7 MHz amplifying stage has a -3 dB bandwidth of 500 kHz and a -60 dB bandwidth of 5 MHz.

For the display of larger bandwidths, 100 to 500 MHz used for example in the investigation of harmonic and spurious signals, this resolution is optimal. The output signal of the IF converter can then be directly fed to the logarithmic display amplifier in order to present a dB-linear display. If a higher resolution is required then an appropriately dimensioned filter can be included in the signal path. The design of suitable filters will now be considered.

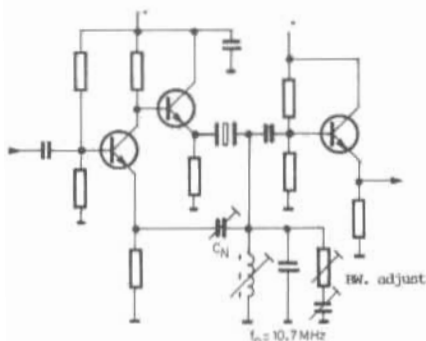

Fig. 3.2:
Crystal filter stage with variable bandwidth

3. THE FILTER BANK

The filter quality determines the spectrum analyser's resolution, i.e. the ability to separate two signals in juxtaposition. Whilst at 10.7 MHz, resolutions of 50 kHz may be obtained with LC circuits, only crystal filters can achieve the lower bandwidths. In fact, it may be stated that one way forward is to select suitable crystal filters from the extensive range offered by firms such as Tele-Quarz or KVG and switch them with relays or diodes into the signal path.



Apart from the fact that each filter costs around DM 150,- they are intended for communication receivers and as such are only of limited use for a spectrum analyser. This is because their steep-sided flanks cause the signal-under-examination to ring as it is swept through the filter. A more suitable passband is bell-shaped, possessing an exponentially falling response equally disposed about the centre frequency in the manner of the so-called Gaus filters. The realisation of such filters is really not so difficult when one is acquainted with the basic circuits of crystal filters. Older amateurs will recall the times when propriety crystal filters were a rarity and filters had to be home-made with surplus crystals.

The basic circuit of a quartz filter is shown in **fig. 3.1**. The input signal is fed in antiphase, from a transformer to a crystal and to a preset capacitor thus forming a bridge circuit. If it is remembered that a crystal is basically a high Q, series-tuned circuit having a parallel holder capacitance then the function of the bridge circuit becomes a little clearer. The capacitive preset arm neutralizes the stray parallel crystal holder capacitance leaving the bandwidth to be determined by the crystal Q and the terminating resistance R. If this preset is made variable, the filter may be tuned over a range of frequencies.

A practical circuit is shown in **fig. 3.2**. The transformer has been replaced by an amplifying stage with two low-impedance outputs and the termination by an LC circuit tuned to the crystal's nominal frequency. This circuit has the advantage that the ever-present unwanted crystal resonances are suppressed completely by this form of termination. An adjustable attenuation, or tuning of the tuned circuit, alters the loading on the crystal and thereby the circuit bandwidth. The output must be loaded by the next stage with a higher impedance.

One such filter stage offers a selectivity of around 20 dB and therefore several must be cascaded. The supply of suitable crystals presents no problems if a quartz filter from a 50 kHz step PLL (from an old NÖBL) transceiver is taken apart and identical crystals extracted. An experimental circuit with four cascaded filters of the type shown in **fig. 3.2**, yielded a 1 to 20 kHz (-3 dB) tunable

bandwidth and a form factor ($BW (-3 \text{ dB})/BW (-60 \text{ dB})$) of 10 – sufficient for most purposes.

The final version of this filter with four cascaded stages is shown in **fig. 3.3**, complete with a bypass line and final amplification. The bandwidth switching is carried out by means of diodes which switch in the various attenuation networks in parallel with the tuned circuit.

The adjustment for this filter is only possible by the use of a sweep generator test set-up. Most commercial sweepers are of little use for this purpose as they are not able to sweep with precision over such small deviations. The best solution is to make one from a VCO at 10.7 MHz, tuned by a varicap diode over a range of ± 100 kHz. The sweep frequency should also cause the Y amplifier of an oscilloscope to traverse the trace synchronously with it.

Each stage is tuned individually by adjusting the load tuned-circuit for maximum bandwidth. The neutralizing capacitor is then tuned so that the response curve is symmetrical about 10.7 MHz. The fine tuning will be carried out later in the finished analyser for a symmetrical overall response and highest-possible rejection.

The next module in the analyser's signal path to be considered is the logarithmic amplifier.

4. THE LOGARITHMIC DISPLAY AMPLIFIER

It is not normally consequential simply to amplify the IF signal at this stage and to linearly rectify it for presentation to the monitor screen. This would result in signals which have at the most a 20 dB amplitude difference being represented correctly on the same trace. Instead, an amplifier/rectifier arrangement is employed which delivers an output which is proportional to the logarithm of the input voltage. The accuracy of this conversion process determines the level of the instrument.

The actual functioning of this type of chain-rectifier/amplifier will not be considered here as

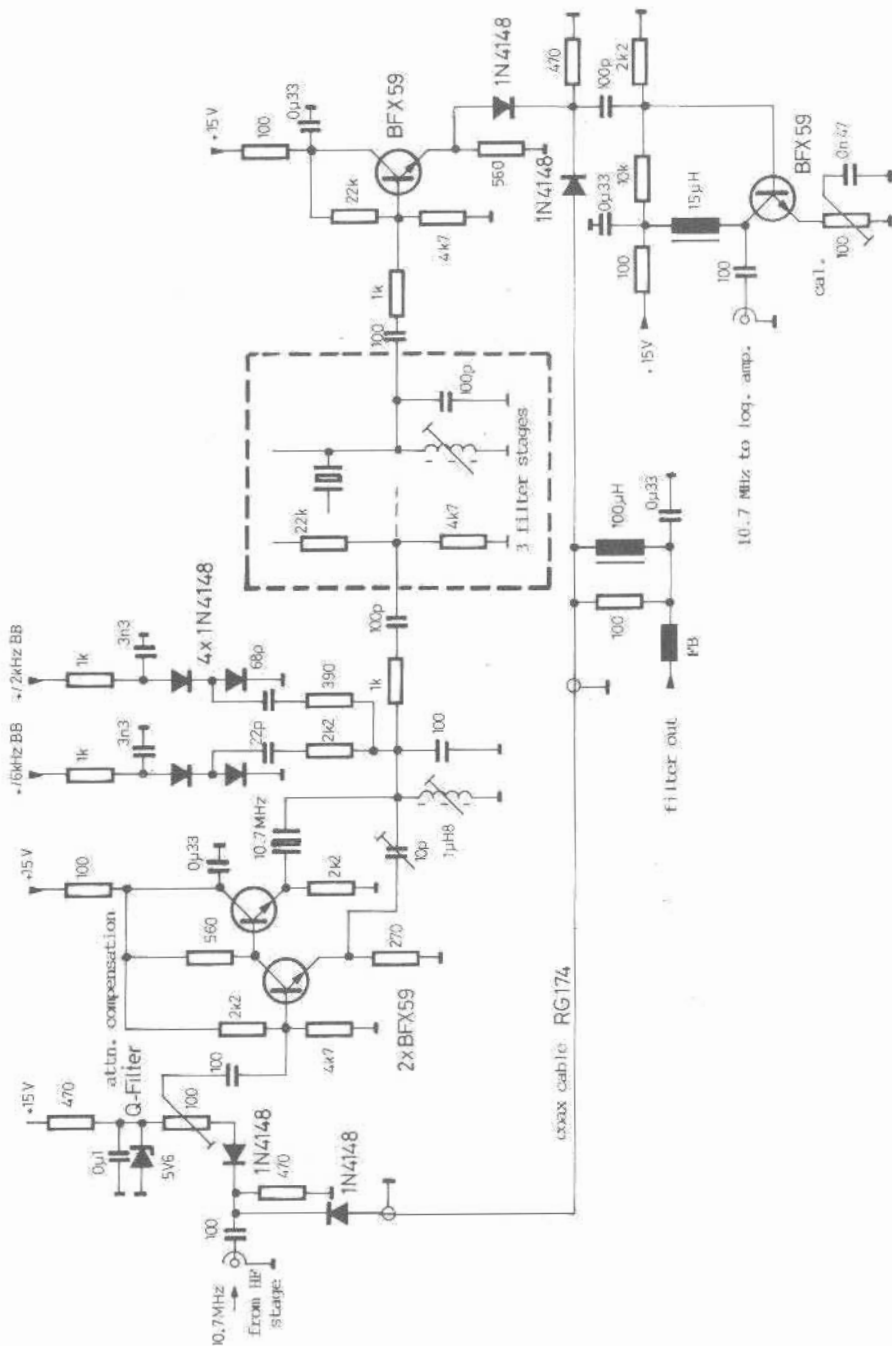

Fig. 3.3: Spectrum-analyser crystal filter module having four cascaded filters

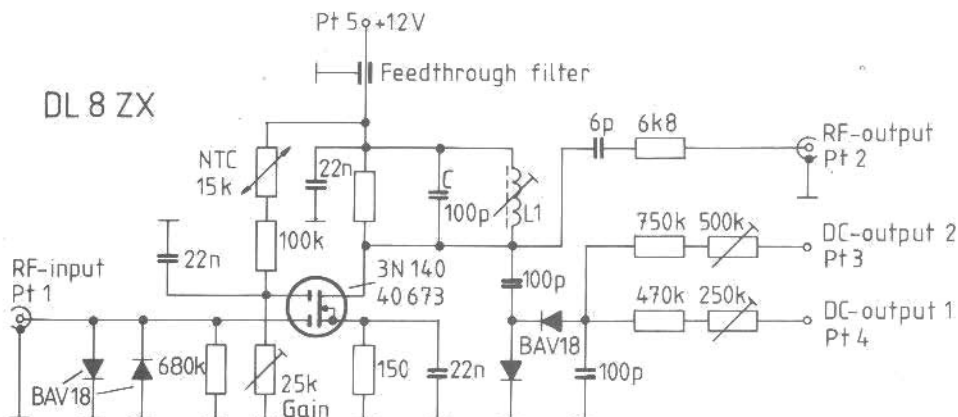

Fig. 4.1: One stage of a chain of rectifier/amplifier (DL 8 ZX)

it has been extensively treated in VHF COMMUNICATIONS 2/1977 by DL 8 ZX. The circuit considered in that article is reproduced in fig. 4.1. It is distinguished by its simplicity and easy reproduction. The main disadvantage is that each amplifier has four adjustment points which makes the calibration a bit of a head-ache. Today, semiconductors are much cheaper than they were a decade ago and therefore a trade-in can be made of a little more complexity for ease of calibration. The author obtained his inspiration from an in-

dustrial (Hewlett-Packard) logarithmic amplifier and modified it with the following results:—

- The amplifier stages consist of bipolar differential amplifiers whose gain is fixed by resistors and is therefore reproducible and does not need provision for adjustment. No tuning is required as the circuit has no tuned elements so, of course, the selectivity of the display amplifier is minimal.
- Instead of summing the outputs of the instrument rectifiers of each stage the HF voltages of each stage are combined and presented to one instrument rectifier. This obviates any necessity to match individual stage rectifiers. Any deviation from the required demodulator characteristics can be corrected by an adjustment to the summing resistances.
- The linear/dB presentation of the spectrum is effected with only a single rectifier.

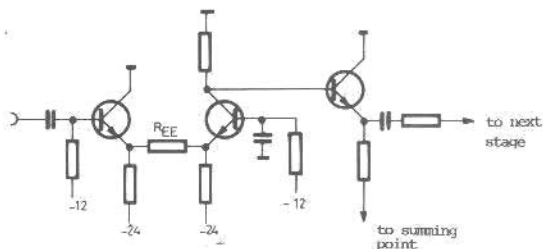

Fig. 4.2: One stage of a logarithmic display amplifier

Fig. 4.2 shows a single differential amplifier stage and fig. 4.3 the practical circuit having a 70 dB dynamic range. Actually, each differential

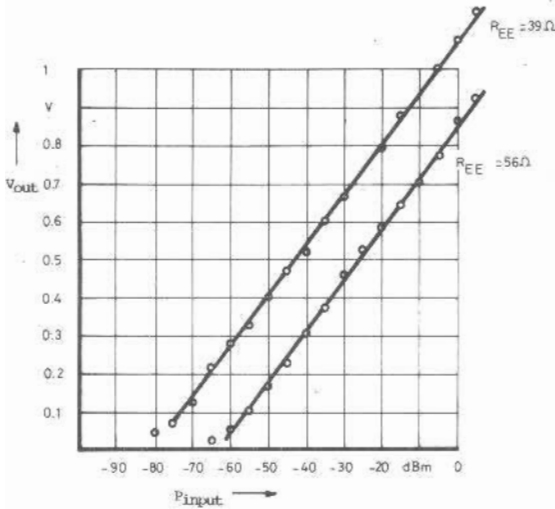

Fig. 4.4:
The characteristic curve of display amplifier of fig. 4.3

amplifier stage should have a constant current supply arrangement in its emitter but it has been found that a single high resistance will suffice. The negative rail, however, must be relatively high – in this case – 24 V. Apart from the in-

creased dissipation, this practice has no particular disadvantage.

The level accuracy of such an amplifier lies in the order of 1 to 2 dB absolute, which is considered to

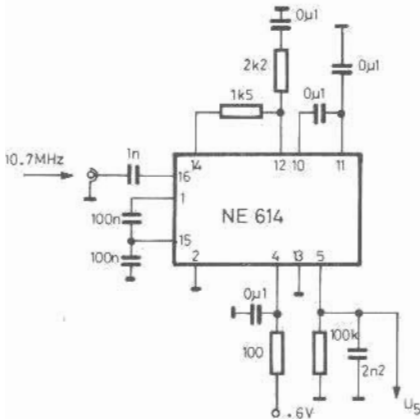

Fig. 4.5a: The NE 614 as a logarithmic display amplifier

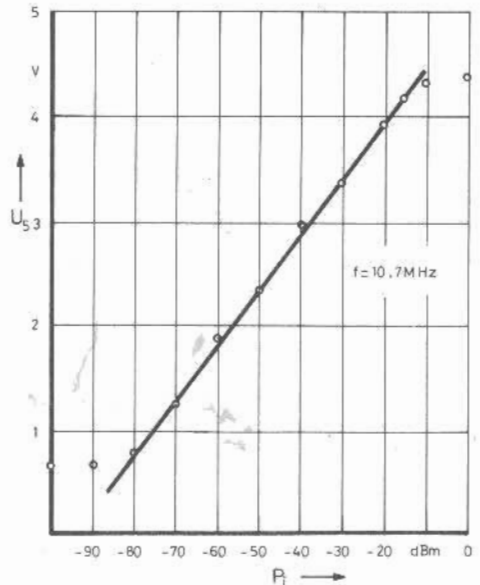

Fig. 4.5b: The characteristic curve of the NE 614 amplifier

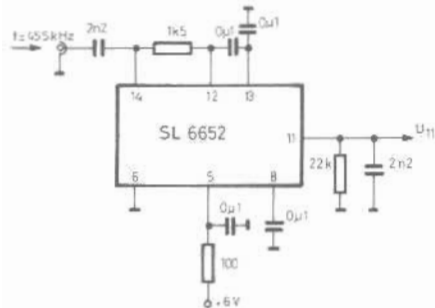

Fig. 4.6a: The SL 6652 as a logarithmic display amplifier

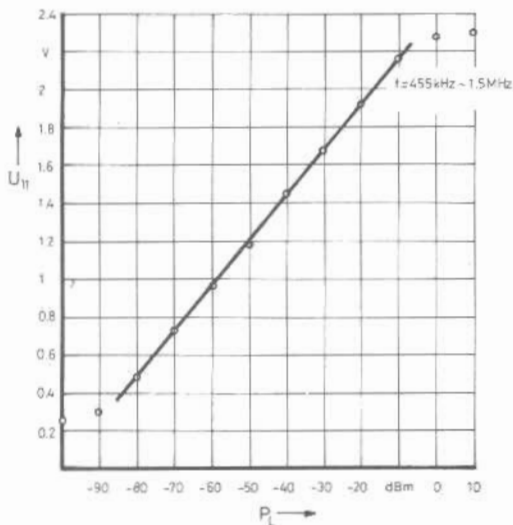

Fig. 4.6b: The characteristic of the SL 6652 log. amp.

be sufficient. The characteristic shown in **fig. 4.4** is that of the prototype amplifier shown in **fig. 4.3**. The accuracy can be improved by decreasing the resistance between each stage and thereby reducing the amplification but there is also a reduction in the dynamic range. If this resistor is dropped from 56Ω to 39Ω , for example, over 70 dB of dynamic range can be obtained but the maximum error also increases by ± 1 dB.

A supplementary demodulator, connected to the last amplifying stage, supplies a linear output from an IF input signal. This latter amplifier stage may be connected to the monitor deflection amplifiers and is very useful for more accurate minimal or maximal tuning adjustments as a linear change in level is easier to observe.

It can be seen that both modules can be employed as logarithmic IF amplifier/detectors if the demands upon dynamic range and linearity are not too great.

A further possibility for the realization of a logarithmic IF amplifier is the employment of the

purpose-built Plessey differential amplifier series SL 521, SL 523, SL 1521, SL 1523, or SL 1613. All suffer from the disadvantage that they have a large (150 MHz) bandwidth. The wideband noise could be held within bounds by placing tuned circuits between each stage but this would increase the complexity. This circuit technique was not therefore pursued further.

If so much complexity is to be avoided, there are many FM/IF chips which can be used which have a dB-linear characteristic. The VALVO NE 614 is an IF/demodulator chip for frequencies to 15 MHz and the Plessey SL 6652 has an IF limit of only 1.5 MHz but it does have an internal mixer/oscillator circuit at the designer's disposal. The experimental circuit for the NE 614 is shown in **fig. 4.5a** and the IF (10.7 MHz) input signal (dB) versus output voltage is shown in **figs. 4.6a** and **4.6b** respectively, but the input frequency in this case was 455 kHz. It can be seen that the SL 6652 has a more linear characteristic but a frequency translation is required from 10.7 MHz to under 1.5 MHz.