

Price \$1.00

Operating and Maintenance
Instructions for the

CONAR

Signal Generator

Model 280

QUALITY EQUIPMENT BUILT ON A HALF CENTURY OF SERVICE IN ELECTRONICS

CONAR

Model 280 Signal Generator

Operating and Maintenance Instructions

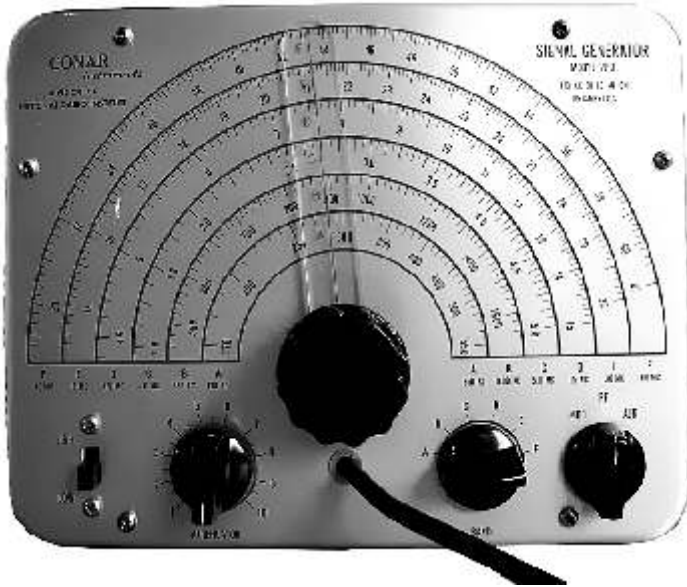

SPECIFICATIONS

Accuracy: Better than 3% after calibration.

Attenuator: Course: High-Low switch.
Fine: Continuously variable potentiometer.

Output Cable: Permanently attached,
low loss coaxial, terminated in alligator clips.

Output Amplitude:

Bands A, B, and C:
at least 1 volt peak to peak.

Bands D, E, and F:
at least 20,000 microvolts.

Audio:
at least 5 volts peak to peak.

RF and Modulated RF continuously
variable within six bands.

Band A 170 kc to 550 kc

Band B 550 kc to 1600 kc

Band C 1.6 mc to 5.0 mc

Band D 4.5 mc to 15 mc

Band E 15 mc to 30 mc

Band F 30 mc to 60 mc

Cabinet Size:

7-1/2" high x 9-7/8" wide x 6-1/2" deep

Weight:

9 lbs (shipping weight)

Power Requirements:

115 volts, 60 cycles AC, 10 watts

Tube Complement:

(1) 6BE6, (1) 12AU7

Power Supply:

Power Transformer and Selenium rectifier.

Output:

RF; 170 KC to 60 MC,

RF Modulated; 170 KC to 60 MC by 400 cps,

Audio; 400 cps audio signal

Operating Instructions:

The CONAR Model 280 Signal Generator is easy to operate. The front panel labels for the controls and scales enable you to set up the instrument for the output signal you desire. The following discussion of the controls, the scales, and the circuit is included to help you become thoroughly familiar with the instrument.

DESCRIPTION OF CONTROLS

The operating controls of your CONAR Signal Generator are conveniently grouped for easy operation. Let's consider the function of each control as it relates to the operation of the instrument.

Function Switch:

This three-position switch, marked MOD, RF, and AUD is used to select the type of output that you get from the instrument. In the AUD position, the output is a 400-cycle sine wave used for testing audio equipment. In the RF position, the output is an unmodulated RF signal at the frequency determined by the band switch and tuning control, in the MOD position, the output is an RF signal amplitude modulated by the 400-cycle audio signal.

Band Switch:

This six-position switch is used to select the band of frequencies produced by the generator. Each position is marked to correspond with one of the six scales on the dial. The bands cover the following frequencies:

Band A 170 kc to 550 kc
Band B 550 kc to 1600 kc
Band C 1.6 mc to 5.0 mc
Band D 4.5 mc to 15 mc
Band E 15 mc to 30 mc
Band F 30 mc to 60 mc

*1600 kc and 1.6 mc are the same frequency.

Tuning Control:

The tuning control moves the pointer across the dial and adjusts the frequency of the generator within the band of frequencies selected by the band switch. The control has a vernier type drive so you can easily make accurate settings of the output frequency.

Attenuator Control:

This is a continuously variable potentiometer used for adjusting the size of the output signal. An "ON-OFF" switch is ganged to this control. In the extreme counter-clockwise position, the switch is "OFF" and the instrument is de-energized. As you rotate the

control clockwise from the OFF position, you will hear a slight click. This turns the instrument ON. As the control is turned further clockwise, the signal generator output increases.

High-Low Switch:

This is a coarse attenuator for varying the signal generator output over a wide range. The HIGH position is mainly used when testing a receiver or when you want a very large signal to drive through a defective or badly misaligned stage. The LOW position is normally used in alignment work because you need to keep the output signal at a LOW level. The attenuator control is then used to further attenuate the signal to the desired level.

Output Cable:

A coaxial cable comes through the center of the front panel under the tuning control; The cable is permanently attached to the attenuator circuit so that the cable cannot be misplaced. The shielding of the cable confines the output signal to the center conductor of the cable. This enables you to inject the signal where you want it in the receiver and prevents unwanted signal radiation,

HOW TO READ THE SCALES:

The tuning dial has six scales, labeled at each end with letters corresponding to the positions of the band switch. Each scale covers a given band of frequencies. For example, when the band switch is set at position A, readings are made on scale A of the tuning dial. Note that the scales A and B are marked in kilocycles (thousands of cycles), while the other scales (C, D, E, F) are marked in megacycles (millions of cycles). It is easy to convert the frequency from megacycles to kilocycles. All that needs to be done is to move the decimal point three places to the right. For example, 1.6-mc is 1600-kc; 1.8-mc is 1800kc, etc.

As an aid in selecting the correct setting of the band switch, the lowest and highest frequencies covered by each band are indicated at the extreme ends of each corresponding scale on the tuning dial. Example: Beneath the left end of Scale A is printed 170-kc. Beneath the right end of Scale A is printed 550-kc. Therefore, if any frequency between 170-kc and 550-kc is desired, the band switch is set to position A. The tuning control is then turned so that the red "hairline" on the plastic pointer is directly over the desired frequency on scale A.

Where a number representing the desired frequency is directly marked on the dial, the transparent pointer

is moved over the dial until the hairline is directly over the long marker line representing that frequency.

If the signal generator is to be set to a frequency not directly labeled on a given scale, then the short lines between the longer marker lines are used. For intermediate readings, an estimation is made between the short lines. The values represented by each division (short line) between calibrated or marked lines for the different bands are given below:

Band A, each division represents 10-kc.

Band B, between 550-kc and 800kc, each division represents 10-kc.

Between 800-kc and 1600-kc, each division represents 20-kc.

Band C, each division represents .05-mc or 50-kc.

Band D, each division represents .1-mc or 100-kc.

Band E, each division represents .1-mc or 100-kc.

Band F, each division represents .2-mc or 200-kc.

Let's take an example of selecting a desired frequency. Suppose you want the signal generator to produce a frequency of 1430 kc, Referring to the main dial scale, we see the minimum frequency covered by band B is 550 kc and the maximum frequency is 1600 kc. Since the frequency we want falls between these limits, the band switch is set at position B which covers the standard AM broadcast band of frequencies. Next we find the line marked 1400 kc on the B band. The next higher marked line is 1600 kc. Halfway between 1400 and 1600 we find a long line. We know this line is 1500 kc because It is halfway between 1400 and 1600. The short graduations between 1400 and 1500 mark off five spaces. Each space must represent 20 kc because the five spaces cover the 100 kc from 1400 to 1500. Therefore, the first graduation above 1400 kc is 1420 kc and the second graduation is 1440 kc. Since we want the 1430 kc, we move the hairline of the pointer halfway between the first and second graduation above 1400 kc. The signal generator is now set to produce 1430 kc.

Avoid Parallax Error:

When setting this plastic pointer to a given frequency, be sure that you are looking directly toward the pointer and dial scale. If your eyes are not squarely in front of the pointer, an error in reading the scale, (called parallax error) will result. Be especially careful when placing the signal generator at one side of the receiver under test. There is a tendency to read the dial from an angle.

CIRCUIT DESCRIPTION

The CONAR Model 280 Signal Generator uses simple, reliable circuitry to produce an RF, modulated RF, or audio output. The RF signals are generated in six bands by switching different coil and capacitor combinations to the oscillator tube. Within each band, the frequency is continuously variable by adjusting the tuning capacitor. The dial pointer is attached to the tuning capacitor to indicate the exact frequency within the band. The RF signal from the oscillator is coupled to a cathode follower output stage. The output signal then passes through an adjustable attenuator to the output cable.

The modulated RF output is produced by modulating the RF signal in the oscillator stage. A 400-cps (approximately) audio signal is applied to the mixer grid of the RF oscillator stage to amplitude modulate the selected RF signal. The modulated RF signal is coupled to the cathode follower in the same way as the RF signal.

A fixed frequency (approximately 400 cps) audio signal is generated by an audio oscillator stage. When the audio output is selected, the signal is applied to the cathode follower, passes through the attenuator circuit, and appears at the output of the output cable. As previously described, the audio signal is also used internally to modulate the RF signal when the modulated RF output is selected.

The circuit of the Model 280 is shown in Fig. 1. The Hartley type oscillator circuit was selected for its stability. Six separate coils and capacitors form the oscillator tank circuits. A different tank circuit is switched to the oscillator tube for each of the six bands of frequencies. The band switch, S1, shorts out all the coils except the coil for the selected band. A ganged variable tuning capacitor varies the frequency over the selected band. The tuning capacitor, C7, has two sections, one section for the four low bands and one section for the two highest bands. This arrangement assures a favorable L-C ratio for the oscillator circuits over all the frequency bands.

The RF oscillator tube, V1, is a 6BE6 pentagrid converter tube. This tube functions as an electron coupled oscillator. The cathode, the first control grid (pin 1), and the screen grid (pin 6) act as a triode to operate the RF oscillator. The electrons that pass through the grids and reach the plate are the electron coupled output from the oscillator, in this way the load placed on the output of the oscillator does not

affect the frequency of oscillation. Grid 3 (pin 7) is used to amplitude modulate the oscillator frequency. A 400-cycle signal is applied to this grid when the function switch is set to the modulated RF position.

The oscillator output from the plate of V1 is coupled through C9 to the grid of the cathode follower. The 1-2-3 section of the 12AU7, V2, forms the cathode follower output of the signal generator. The use of a cathode follower provides a low impedance output from the signal generator and acts as an additional guard to prevent the output load from affecting the frequency of the oscillator.

The 6-7-8 section of V2 and the associated components form a Colpitts type audio oscillator. L7, C12, and C13 are the frequency determining elements of the circuit. The oscillator produces a sine wave at a frequency of approximately 400 cps. In the modulated RF position, this signal is fed through R6, C14, and S3 to grid 3 (pin 7) of the oscillator tube. In the audio position, the 400-cycle signal is fed to the grid of the cathode follower. Notice that in the audio position, B+ is removed from the plate and screen of V1 so there is no RF output.

The output from the cathode follower is fed to the output cable through an attenuator network. The 3K potentiometer, R11, provides a continuous variation of the output. High-Low switch, S4, provides a large step-change in the output signal. Both the High and the Low output are continuously variable. The output from the attenuator network is coupled through C17 to the output cable. This capacitor isolates the signal generator circuitry from the receiver you are working on. Thus it is safe to inject a signal to the plate of a tube in a receiver even though the plate has B+ voltage on it. The output cable is a low capacitance coaxial cable. The grounded coaxial shield prevents signal radiation from points other than the output clip on the end of the cable.

The power transformer provides isolation of the instrument from the power line. The voltage from the high-voltage secondary on the transformer is rectified and filtered to provide B+ for the instrument. The low-voltage secondary provides filament voltage for the tubes.

How to Align Radio Receivers with the Signal Generator

Your CONAR Signal Generator can be used for testing and aligning AM and FM radio receivers. The

400 cycle output is a convenient test signal for use on all types of audio equipment.

If you have never done any alignment work you will want to try out the instrument before you use it to repair or align a defective receiver. The section on alignment in this manual is to be used only as a general guide. When aligning a specific receiver we recommend that you follow the manufacturer's instructions,

Skill in aligning all types of receivers takes practice and experience. One of the best ways to start getting this experience is to practice alignment on receivers that are already properly aligned. Set up the equipment and follow the alignment steps without making any adjustment to the receiver. This will give you practice injecting signals and observing indications. Next, you can move adjustments in the receiver and observe the effect. This will give you a feel of how the adjustments should respond. Mark the position of the adjustment before you move it so you can put it back in case you are on the wrong adjustment. Most inexpensive AC-DC radios are slightly out of alignment even when new. Realignment several of these sets can give you valuable experience in using your instrument.

RECEIVER ALIGNMENT --GENERAL

Alignment is the process of adjusting tuned circuits to respond to a desired frequency or band of frequencies. In a superheterodyne radio receiver, the tuned circuits consist of the RF stages, the IF stages, and the local oscillator circuit. The RF stages are aligned to produce maximum response to the band of frequencies covered by the particular receiver. The local oscillator must be adjusted so it will "track". That is, the local oscillator must produce the correct frequency at all settings of the radio tuning dial. The correct frequency is the frequency that when mixed with the incoming signal from the desired radio station produces a fixed intermediate frequency. The IF stages are adjusted to give maximum response to the intermediate frequency (usually 455 kc).

To align tuned circuits, it is necessary to have a signal source and a response indicator. Your signal generator provides the signal source at the frequency that the tuned circuit is to be aligned. You can use any one of several methods to indicate the response of the tuned circuit to the applied signal. The simplest method is to use the speaker of the receiver. The signal

from the signal generator must be modulated to produce an audible tone from the speaker. Then as the circuits are aligned, you judge the response by the loudness of the tone from the speaker, Since it is difficult for the ear to detect small changes In loudness, other methods are considered more accurate. However, using the speaker as a response indicator is entirely satisfactory for aligning radio receivers.

Another method of indicating the response of the tuned circuits in a receiver is to connect a scope or AC voltmeter across the voice coil of the receiver speaker. This gives you a visual indication of the response as you adjust the tuned circuits.

Another popular method of indicating the response is to connect a DC voltmeter to the output of the second detector. The meter is very sensitive to small changes in circuit response. With this method you can use an unmodulated signal and you do not have to listen to the tone from the loudspeaker. One precaution: If a circuit you are aligning breaks into oscillation, your indicating meter will show a high false reading. It will be necessary to find and correct the cause of oscillation (usually feedback) before you can peak the tuned circuit. Otherwise you will have to align the circuit slightly off resonance where oscillation does not occur. When an oscillating condition is suspected, use an unmodulated signal and listen to the output. This enables you to detect an oscillating circuit condition because the receiver will produce squeals or motor boating noises. You can still use your DC meter as the response indicator,

Injecting the Signal:

It is necessary to inject the proper amount of signal into the tuned circuit without detuning the circuit to be aligned. This is usually accomplished by injecting the signal into a stage ahead of the stage being aligned. For example, to align IF stages, the signal is applied to the control grid of the mixer stage. The mixer tube isolates the tuned IF stages from the signal generator so there is no loading effect. The amplitude of the signal is then adjusted by attenuating the signal generator output.

Minimum coupling should be used to Inject a signal into the RF stages or the pre-selector section of a receiver. Placing the output clips of the signal generator cable near the loop antenna of a receiver will usually radiate enough signal Into the receiver. If the receiver is badly misaligned you can start alignment by connecting the signal generator output

directly to the antenna terminals. This will inject enough signal to drive through even a badly misaligned stage. When you get the set approximately aligned, remove the clips from the antenna terminals and radiate the signal into the set by placing the signal generator clips close to the antenna. This prevents any loading effect of the signal generator during final alignment.

Use Minimum Signal:

Accurate receiver alignment requires the use of a minimum signal. You want the receiver to produce Its maximum sensitivity when receiving weak radio stations, Therefore, final alignment adjustments should be made using a signal strength that is just large enough to give a good indication on your response Indicator. In a receiver using AVC, the signal strength should be small enough so it does not produce an effective AVC voltage. An alternate method is to disable the AVC voltage by shorting the AVC line to B-.

Warm-up Time:

The oscillator of your CONAR Signal Generator is a stable circuit that will show no appreciable frequency drift during warm-up. However, it is good practice to allow the generator to warm up for ten or fifteen minutes before using It. The circuits in some receivers will drift noticeably during warm-up, Therefore, turn on the set and allow it to warm up for about fifteen minutes before starting the alignment procedure,

Disabling the Local Oscillator:

When aligning the IF section of a receiver, it is desirable to disable the local oscillator. This prevents the local oscillator signal from beating with the signal generator signal and producing confusing signals, The local oscillator can be disabled by shorting the oscillator section of the tuning capacitor.

Obtaining Maximum Sensitivity:

To obtain maximum sensitivity from a radio receiver you can use an alignment procedure known as "rocking". This procedure may produce inaccuracies in the dial readings of the radio, however, the dial markings on most broadcast radio receivers are only a rough indication of the frequency that the radio is tuned to. Therefore, the disadvantage of small inaccuracies in the dial settings is more than offset by the improved receiver sensitivity.

The "rocking" alignment procedure can be used on any receiver having a padder capacitor or a tuning slug in the local oscillator coil. In most cases, the

V1 MIXER - OSCILLATOR 12BE6
 V2 I-F AMPLIFIER 12BD6
 V3 2ND DETECTOR 12AT6
 V4 OUTPUT 50C5

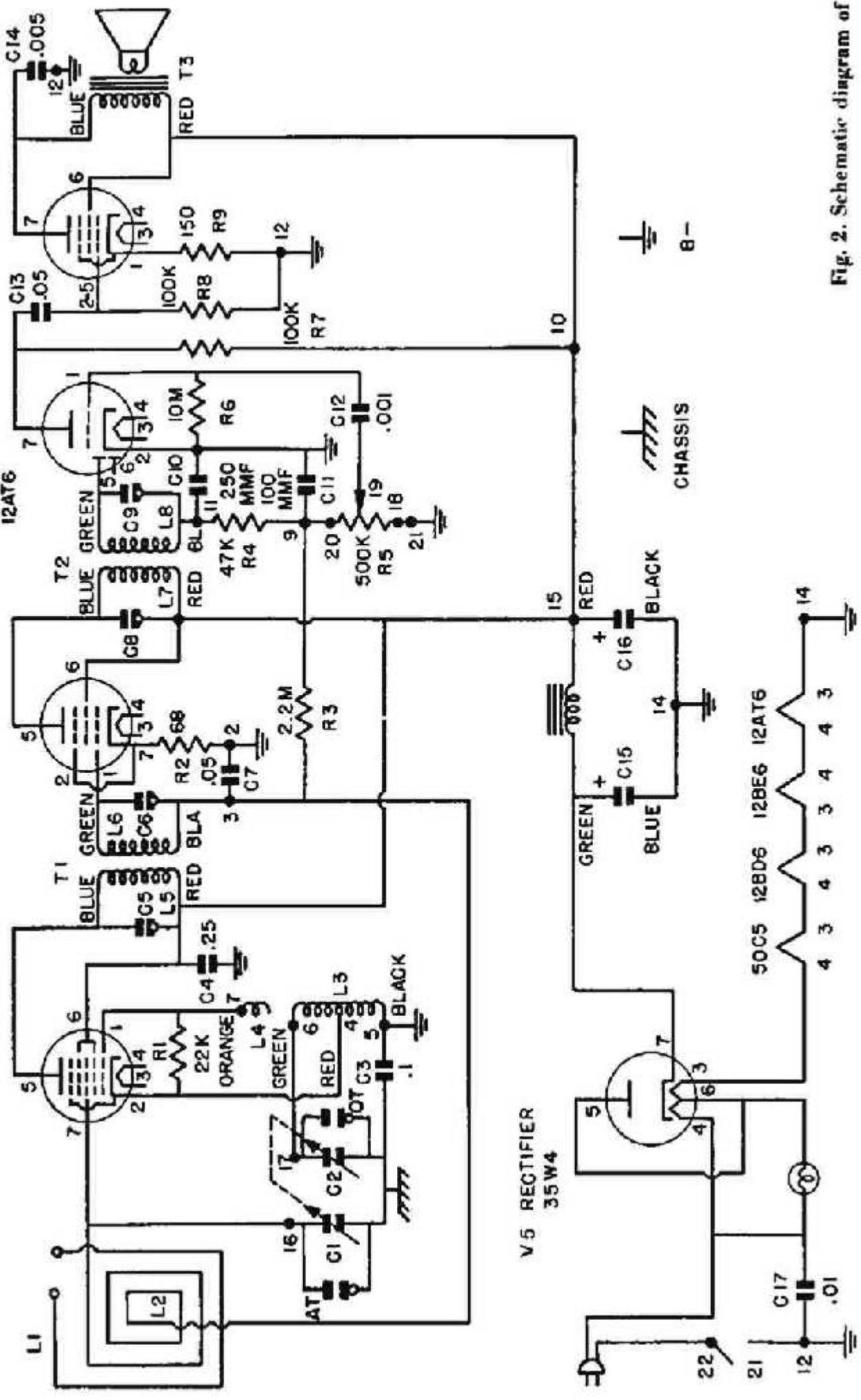

Fig. 2. Schematic diagram of a typical AC-DC radio receiver.

receiver will be a transistor set because most modern tube broadcast receivers do not have a padder. In the following discussion, the word "padder" refers to the padder capacitor or the tuning slug in the oscillator coil.

First, adjust the oscillator and RF trimmers for maximum output at 1500 kc with the receiver dial set at 1500 kc. The RF section of the receiver is now properly aligned and should not be adjusted again.

Next, set the signal generator tuning control to 600 kc. Tune the receiver to produce maximum output Indication regardless of dial setting. Write down the exact dial reading.

Change the setting of the padder slightly. Retune the receiver for maximum output, and make a note of the output. If the output has increased, you are adjusting the padder in the correct direction; if the output has decreased, you are adjusting the padder in the wrong direction.

If you are adjusting the padder in the correct direction, continue adjusting the padder In that direction, retuning the receiver dials until maximum output Indication is obtained. Of course, you must tune the padder slightly beyond the correct point (where the output begins to decrease) and then come back to make certain you have the maximum.

If the original padder adjustment was in the wrong direction, turn the padder In the other direction, retune the receiver and note the output. Continue this procedure until maximum output is obtained, again, you will have to tune slightly beyond the correct point to make certain you have the maximum output.

This "rocking" adjustment increases the receiver sensitivity at the expense of exact dial calibration by effectively adjusting the oscillator and the pre-selector simultaneously. The combination of setting the padder and the receiver dial adjusts the oscillator; setting the receiver dial adjusts the mixer and the pre-selector.

After performing the "rocking" adjustment at the low end of the receiver dial, you must adjust the oscillator trimmer capacitor at the high end of the dial.

Repeat these adjustments until the dial calibration is correct at the high end of the dial, and the padder is adjusted for maximum response at the low end of the dial, when you have done this, the receiver will track

reasonably well and maximum sensitivity will be obtained over the entire tuning range.

STEP BY STEP ALIGNMENT OF A TYPICAL VACUUM TUBE RADIO RECEIVER

The following alignment procedure is presented as an example that can be used for aligning receivers when instructions are not available, if the manufacturers alignment data is available, it should be used. Fig. 2 shows a typical AC-DC broadcast receiver; Use this schematic to follow the alignment steps.

1. Plug in and turn on both the Signal Generator and the receiver to be aligned, Allow a few minutes for them to warm up.

2. Connect a DC voltmeter across the volume control. You could, of course, use one of the other response indicators discussed previously. The volume control in Fig. 2 is the 500K potentiometer, R5. Connect the voltmeter to terminals 20 and 18. The high end of the volume control will have a negative potential so set the meter to read DC on the 3-volt scale.

3. Short the oscillator section of the tuning capacitor, C2. This can be done by connecting a jumper from terminal 17 to the chassis. This disables the receiver's local oscillator and prevents spurious signals during IF alignment.

4. Disable the AVC voltage by connecting a jumper between terminals 2 and 3, this shorts out capacitor C7 and grounds the AVC voltage.

5. Connect the signal generator output to the terminals of loop L1 at the antenna. Notice that L1 is a single turn of wire near the built-in loop antenna, L2, The output of the signal generator will radiate a signal from L1 into the loop antenna, L2.

6. Set the Signal Generator to produce the receiver's intermediate frequency, In this case, 455 kc, Set the Band switch to A, Tune the Signal Generator so the red hairline on the plastic pointer is over 455 on scale A. Set the function switch to RF. Adjust the attenuator (HIGH-LOW switch and ATTENUATOR control) to produce about 1 volt reading on the response indicator.

7. Adjust the AC-DC trimmers for maximum reading on the response indicator. The IF trimmers are C5, C6,

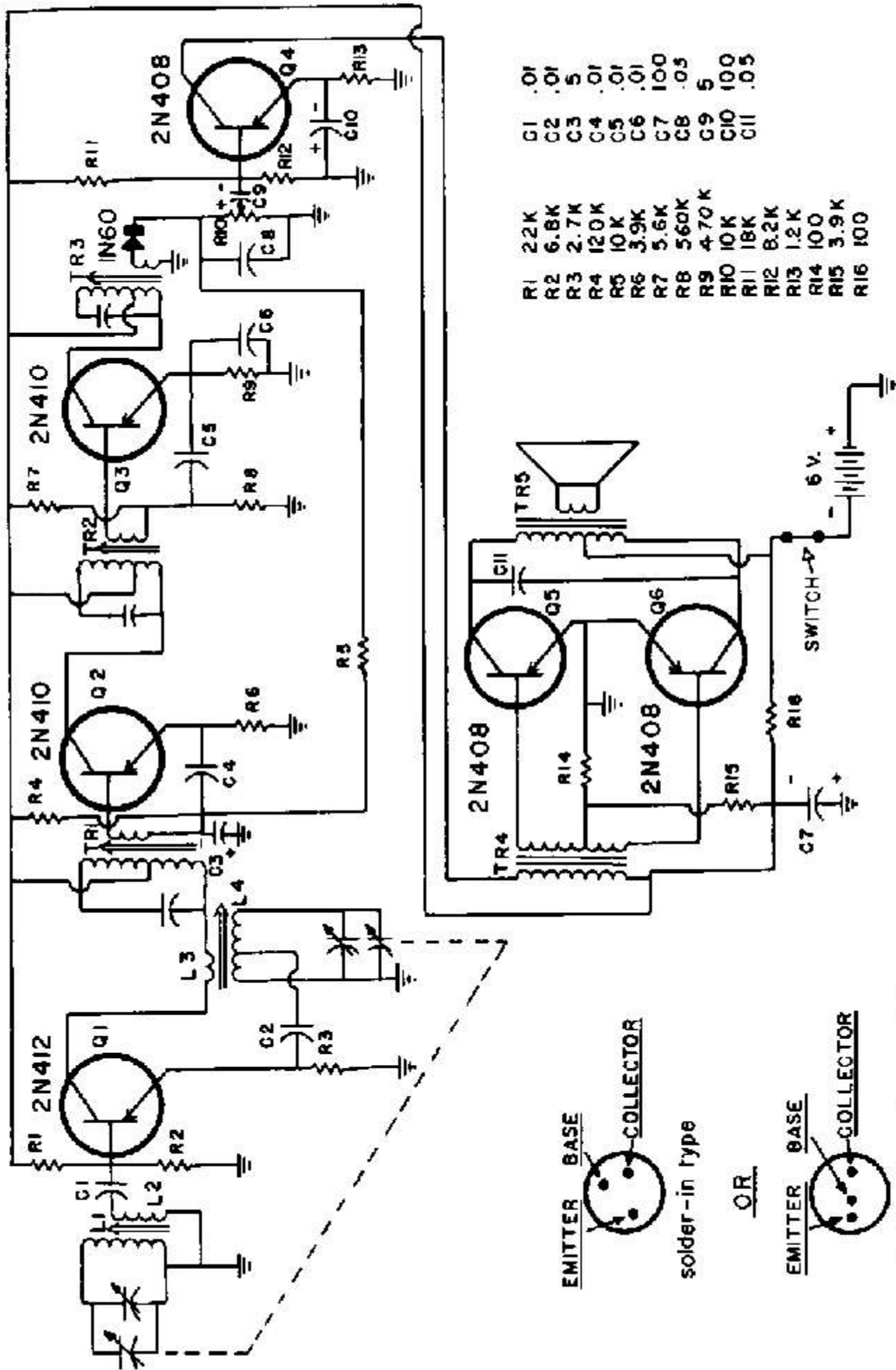

- | | | | |
|-----|-------|-----|-----|
| R1 | 22K | C1 | .01 |
| R2 | 6.8K | C2 | .01 |
| R3 | 2.7K | C3 | 5 |
| R4 | 120K | C4 | .01 |
| R5 | 10K | C5 | .01 |
| R6 | 3.9K | C6 | .01 |
| R7 | 5.6K | C7 | 100 |
| R8 | 560K | C8 | .05 |
| R9 | 4.70K | C9 | 5 |
| R10 | 10K | C10 | 100 |
| R11 | 18K | C11 | .05 |
| R12 | 8.2K | | |
| R13 | 1.2K | | |
| R14 | 100 | | |
| R15 | 3.9K | | |
| R16 | 100 | | |

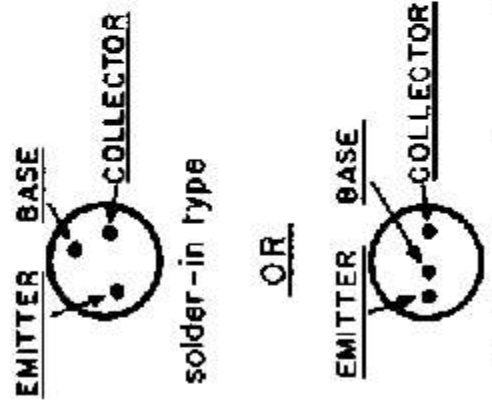

Fig. 3. Typical transistor receiver.

CS, and C9 in Fig. 2, in many receivers, the IF adjustments are made by moving an iron core slug in the IF coil. As you adjust for maximum response, keep attenuating the input signal as necessary to keep the voltmeter reading on scale.

8. Repeat all IF adjustments starting with the second detector adjustment (C9 In Fig, 2) to eliminate the effects of interaction between the adjustments.

9. Remove the short across the oscillator capacitor.

10. Check the position of the dial pointer on the receiver, A calibration point is frequently given at one end of the dial scale to indicate the correct position of the pointer when the tuning capacitor is completely open or completely closed. If such a calibration point is given, make certain it lines up with the dial pointer. If it does not, adjust the dial pointer so it lines up with the calibration mark.

11. Set the receiver dial to 1500 kc. If there is a local station at 1500 kc, set the receiver dial to any frequency between 1500 kc and 1600 kc that can be read accurately from the receiver dial.

12. Set the Signal Generator Band switch and tuning control to the frequency indicated by the receiver dial. Adjust the oscillator trimmer (OT) for maximum reading on the response indicator. The oscillator trimmer is a screwdriver adjustment on the tuning capacitor. C2 in Fig. 2, Also adjust the antenna trimmer (AT) mounted on section C1 of the tuning capacitor gang for maximum output.

13. If the receiver has an oscillator padder adjustment, adjust the padder at 600 kc as discussed in the preceding section under "Obtaining Maximum Sensitivity."

14. Remove the short circuit that you previously placed across capacitor C7. Removing the short circuit allows the AVC voltage to again reach the grids of the tubes and thereby be effective. Disconnect the response indicator and the Signal Generator from the receiver. You now have the receiver properly aligned.

STEP BY STEP ALIGNMENT OF A TRANSISTOR RECEIVER

A transistor receiver is aligned in much the same way as a tube type receiver. The IF stages are aligned first, then the oscillator and mixer circuits. The IF stages are slug tuned transformers. Likewise, the local

oscillator is usually tuned at the low frequency end of the dial by adjusting a slug in a coil or a transformer. The antenna and oscillator trimmers are adjusted at the high frequency end of the dial. The powered iron core in L1 is not adjustable.

When aligning transistor receivers, keep in mind the difference in operation of tubes and transistors. Since transistors are current operated devices, the signal voltages are small at the transistor terminals. The transistors have relatively low input and output impedance. Therefore the transistors are matched into low impedance points in the tuned circuits. Transistors do not provide as much isolation as tubes. A relatively small signal may be coupled through a transistor stage even with the transistor back biased to cut off. The low impedance points in the transistor receiver will severely load down the output of some signal generators. Your Model 280 Signal Generator has a low impedance output that will provide adequate signal for testing at any point in the transistor receiver. However, for alignment purposes It is usually easier to inject both the RF and IF signals into the antenna circuit. A suitable way is to loop the ground lead of the Signal Generator around the loop stick of the receiver. Clip the ground lead and the hot lead together. This arrangement prevents unwanted signal radiation and will radiate plenty of signal into the antenna circuit.

A typical transistor radio receiver is shown in Fig. 3. The first step in alignment is to connect a VTVM between the collectors of the output transistors, Q5 and Q6. An easy place to locate these connection points is at the leads from the primary of the output transformer, TR5. Any of the response indicators discussed earlier may be used but the VTVM is most satisfactory. Since your VTVM will be indicating the detected signal, set the VTVM to read AC on the lowest range. Disable the local oscillator by shorting the oscillator section of the tuning capacitor. This is the section with the fewest plates (In some cases the plates are smaller). Simply connect a lead from the oscillator section terminal to the chassis.

Set up the Signal Generator to produce the IF frequency; in this case 455 kc. Set the band switch to Band A. Rotate the tuning knob to bring the hairline of the plastic pointer to the 455 kc position on the scale for Band A. Set the function switch to modulated RF. Set the High-Low attenuator switch to Low. Rotate the attenuator knob for maximum attenuation (low end of markings). Loop the ground lead of the output cable over the receiver loop stick and clip the hot and

ground leads together as previously explained. Turn on the receiver and turn the volume control to maximum. Increase the output of the signal generator while observing the pointer of the VTVM. Increase the output until you can easily hear the 400 cps modulation. You are now ready to make alignment adjustments.

Adjust the slugs in the IF coils for maximum response. First, adjust the slug in TR3 for maximum Indication on the VTVM. As the VTVM reading increases, attenuate the signal from Signal Generator. Next, adjust the slug in TR2 for maximum response. Attenuate the Signal Generator as necessary to keep the VTVM reading on scale. Finally, adjust the slug in TR1 for maximum response. Keep the generator output as low as possible. This is important for obtaining maximum sensitivity In this stage.

In this receiver, it is impractical to disable AVC because this would remove the forward bias from transistor Q2. Notice that forward bias for Q2 is obtained by applying a negative voltage through R4 and the secondary of TR1 to the base of Q2. This negative forward bias is opposed by a positive AVC voltage. The AVC voltage is picked off the top of R10 and filtered by R5, C3 and C4. If C3 were shorted to remove the AVC voltage, the forward bias would also be shorted and the transistor would remain cut off. Therefore, TR1 should be adjusted while applying a very small IF signal which produces very little AVC voltage. This completes the alignment of the IF section of the receiver.

Next adjust the local oscillator and pre-selector short from the oscillator section of the tuning capacitor. Set the Signal Generator band switch to band B and move the pointer to 600 kc. Tune the receiver so the dial indicates 600 kc. Now adjust the slug in L4 to get a maximum indication on the VTVM. Attenuate the signal from the Signal Generator as necessary to keep the VTVM pointer on scale. Move the pointer on the Signal Generator to 1500 kc. Tune the receiver to 1500 kc. Adjust the oscillator trimmer for maximum indication on the VTVM. Adjust the RF trimmer capacitor for maximum output. The RF trimmer is not to be adjusted again during the remainder of the alignment procedure. Now go back to 600 kc and check the adjustment of the oscillator slug. Perform the "rocking" alignment procedure as described In the section on "Receiver Alignment - General" to get maximum sensitivity. You may prefer to make these adjustments using radio stations, one at the low end and one at the high end of the band,

instead of the Signal Generator. This completes the receiver alignment so disconnect the VTVM and the Signal Generator from the receiver.

FM RADIO RECEIVER ALIGNMENT

Your Model 280 Signal Generator can be used to align the IF section and the detector section of FM Receivers. FM stations can be used to align the RF and converter sections of the receiver. Therefore you can perform the complete alignment of an FM receiver without an FM generator.

In this section we go through the alignment steps of a popular AC-DC FM receiver. A schematic diagram of the receiver is shown In Fig. 4. As you can see from the diagram, one side of the AC power line connects through the ON-OFF switch directly to the radio receiver chassis. This makes the chassis "hot" and presents a dangerous shock hazard. When you connect the ground clip of your signal generator to the receiver chassis, all the metal parts of your signal generator are likewise hot. To protect yourself, plug the receiver Into an isolation transformer. If you do not have an isolation transformer, use your VTVM to tell you when the receiver is plugged into the socket correctly. Connect the ground clip of your VTVM to the receiver chassis. Set the selector to read AC volts on the 120 volt scale. Turn the receiver on-off switch "on." Plug the receiver line cord Into an AC socket. Touch the VTVM probe to a known earth ground, such as the metal parts on the AC outlet, and read the meter. Unplug the receiver and turn the plug over so the prongs fit into the opposite slots of the AC outlet. Again touch the VTVM probe to ground and read the meter. In one plug position the meter will read zero and in the other position it will read line voltage. Leave the receiver plugged into the socket In the position where the VTVM reads zero. You should mark the plug so you can always plug it into the socket in the correct position. This puts the receiver chassis at ground potential and provides you some protection against electrical shock.

The first things to align in an FM receiver are the IF amplifier transformers. Let the receiver and the signal generator warm up for at least 15 minutes. Connect your VTVM between chassis and point A in Fig. 4. Point A can also be identified as pin 2 of V4A. Set the VTVM to read DC on the 3 volt scale. Connect the ground lead of the signal generator to the chassis. Disconnect the antenna from the receiver. Connect the hot lead of the signal generator to the free end (antenna connection) of the 50mmf capacitor, C4.

Turn the receiver volume up full and set the receiver dial to a point where you do not hear any interfering signals. Set up the signal generator to produce 10.7 mc unmodulated RF, which is the IF of this receiver. Do not move the Signal Generator tuning dial during alignment. Even a small change in the generator frequency will require redoing the receiver adjustments. Attenuate the signal so the VTVM reads about midscale. Adjust A1 for maximum indication on the VTVM. Attenuate the signal generator as necessary to keep the VTVM pointer on scale. Notice that A1 is the bottom slug in the ratio detector transformer. This slug is in the primary of the transformer and is tuned to 10.7 mc. in the same way, adjust A2, A3, A4, and A5 in that order. Remember to attenuate the signal generator to keep the VTVM reading on scale. Make the final adjustments with no more signal than is necessary to give a good indication.

Next align the ratio detector. Leave the signal generator connected. Before you remove the VTVM probe from point A, increase the output from the signal generator to give a full 3 volt reading on the VTVM. Connect two matched 100K-ohm resistors in series from point A to the chassis. You can use 1% precision resistors or pick two 100K-ohm resistors that read the same on an ohmmeter. Since you will want to save these resistors to use again for the same purpose, you may want to connect alligator clips on the ends and solder the center connection. Others prefer to tack solder the resistors into the receiver. These resistors are shown in Fig. 4 connected to point A and ground by dotted lines. The junction of the two resistors is alignment point C. Connect the VTVM between point C and point B. The top of the volume control is a convenient place to connect for point B. Set the ohmmeter to read DC on the lowest scale. Adjust A6 (Fig. 4) for zero reading on the VTVM. This adjusts the secondary of the ratio transformer for equal output from the two diodes of the detector. Either side of the correct adjustment point will produce a reading on the VTVM. On one side the reading will be positive; on the other side the reading will be negative.

The IF amplifiers and the ratio detector are now properly aligned. Disconnect the VTVM. Remove the two 100K-ohm resistors that you temporarily connected into the receiver. Disconnect the signal generator.

The RF stage and the local oscillator will be aligned using FM stations. Connect the antenna to the

receiver or attach six or more feet of hookup wire to the antenna terminal to act as an antenna. Connect the VTVM probe to point A and connect the ground lead to the chassis. Set the VTVM to read DC volts on the lowest scale. Allow the receiver to warm up for at least 15 minutes. The local oscillator in many FM receivers will drift a sizable amount during warm up. Since you are working in circuits that pass very high frequency signals, make these adjustments very carefully. It is best to move the adjustments only a small amount at a time. Select a weak FM station near 106 mc or attenuate the signal from the station by using less antenna wire. Identify the station and set the receiver dial to that exact frequency. Adjust A7 until you receive the selected station with maximum indication on the VTVM. When you adjust A7, you are changing the frequency of the local oscillator. If you receive the station at two points in the adjustment of A7, use the point of minimum capacitance of A7 (clockwise rotation of A7 increases capacitance). This places the local oscillator frequency 10.7 mc above the frequency of the incoming RF. Now adjust A8 for maximum indication on the VTVM. Trimmer capacitor A8 adjusts the tuned plate circuit of the RF pre-selector amplifier. The oscillator and pre-selector are now properly aligned at the high end of the FM band.

Now align the pre-selector and local oscillator at the low end of the band. Select an FM radio station near 90 mc. Identify the station and set the receiver dial to the exact frequency of that station. Adjust A9 to receive the station and produce a maximum indication on the VTVM. In this receiver, A9 and A10 are known as "padder flaps." They consist of small flaps of metal positioned close enough to the coils to affect the inductance of the coils. Moving the flaps closer or farther away changes the inductance and thereby tunes the tank circuit. After adjusting A9, adjust A10. Move A10 as necessary to produce a maximum indication on the VTVM.

After adjusting the pre-selector and local oscillator at the low end of the band, it will be necessary to check the adjustment of A7 and A8 at the high end of the band. Repeat the procedure at the low end and the high end, as necessary, until no further improvement is possible. This completes the receiver alignment. Disconnect the VTVM from the receiver.

Many FM receivers do not have padder adjustments for tuning the RF and oscillator coils at the low end of the band. If adjustment is necessary, it is made by spreading apart or squeezing together the turns of the

coil. You will find a tuning wand to be a great time saver in making these adjustments. A tuning wand consist of a plastic rod with a small amount of powdered iron imbedded at one end and a piece of brass imbedded at the other end. When a coil is correctly tuned, you can insert either end of the tuning wand into the coil and the output of the receiver will decrease, if the output increases when you insert the brass end, less inductance is needed and you must spread the turns of the coil. If the output increases when you insert the powdered iron core end, more inductance is needed and you must squeeze the turns of the coil together. In this way, you use the tuning wand to temporarily change the inductance of the coil so you know whether to squeeze or spread apart the turns of the coil.

The above procedure for aligning an FM receiver can be used for aligning most commercial FM receivers. Whenever possible you should consult and follow the manufacturer's alignment instructions for the particular set you are working on.

Maintenance

If you assembled your Signal Generator from a kit, you will want to refer to this section to check the operation of the instrument before you install it in the cabinet. Also, you may want to check the alignment of the Signal Generator.

If you purchased your Signal Generator already assembled, you need not refer to this section at this time. However, if your Signal Generator gives you trouble at some future time, the information in this section will help you put it back in tip-top operating condition.

CHECKING OPERATION OF THE SIGNAL GENERATOR

Your Signal Generator will probably operate properly when you first turn it on. However, the possibility exists that you have made a wiring mistake, so check the operation before installing it in the cabinet.

Plug the line cord into a 115-volt 60-cycle AC supply. Turn the attenuator control clockwise to turn the on-off switch "on". Observe the vacuum tubes. The filaments should glow after a few seconds. Set the high-low switch to the high position. Set the attenuator control about mid-range. Set the band switch to B, Set the function switch to MOD. The

Signal Generator is now set up to produce modulated RF signals in the broadcast band. Clip or lay the output cable near a radio receiver. Tune the radio dial to a position where no station is being received. Now tune the Signal Generator across the "B" band. When the Signal Generator is tuned to the same frequency as the radio receiver, a 400-cycle tone will be heard from the radio.

You can check for operation of the Signal Generator in the RF position by beating the generator RF signal against a received radio station. Tune your radio receiver to receive a radio station. Tune the Signal Generator (function switch at MOD position) to the same frequency so you can also hear the modulated tone. You may have to attenuate the signal from the generator so it doesn't blot out the station. Now switch the function switch on the signal generator to the RF position. Tune the Signal Generator a small amount on either side of the frequency of the received radio station. You will hear an audible beat signal that varies in frequency as the signal generator is tuned. When the beat signal is reduced to zero frequency, the Signal Generator and the radio station are both producing exactly the same frequency.

With the instrument out of the cabinet, the attenuator controls may not have much effect on the loudness of the signal because considerable signal is radiated directly from the chassis. After the instrument is installed in the cabinet the chassis will be shielded by the cabinet and the radiated signal will come almost entirely from the clip on the output cable.

You can check the operation of the Signal Generator in the audio position by connecting the output to an audio amplifier. You can use the audio section of a radio receiver. Connect the ground clip of the output cable to a B- (gnd) point in the radio. Clip the center lead of the output cable to a point in the audio signal path, such as the grid of the first audio amplifier. Switch the function switch to AUD. The 400-cycle audio sound can be varied in volume by adjusting the attenuator controls on the Signal Generator.

You can check the operation of the other RF bands in the same manner if you have a communications receiver that will tune to these frequencies. If the Signal Generator operates on one band, you will undoubtedly find that it operates satisfactorily on the other bands.

FRONT

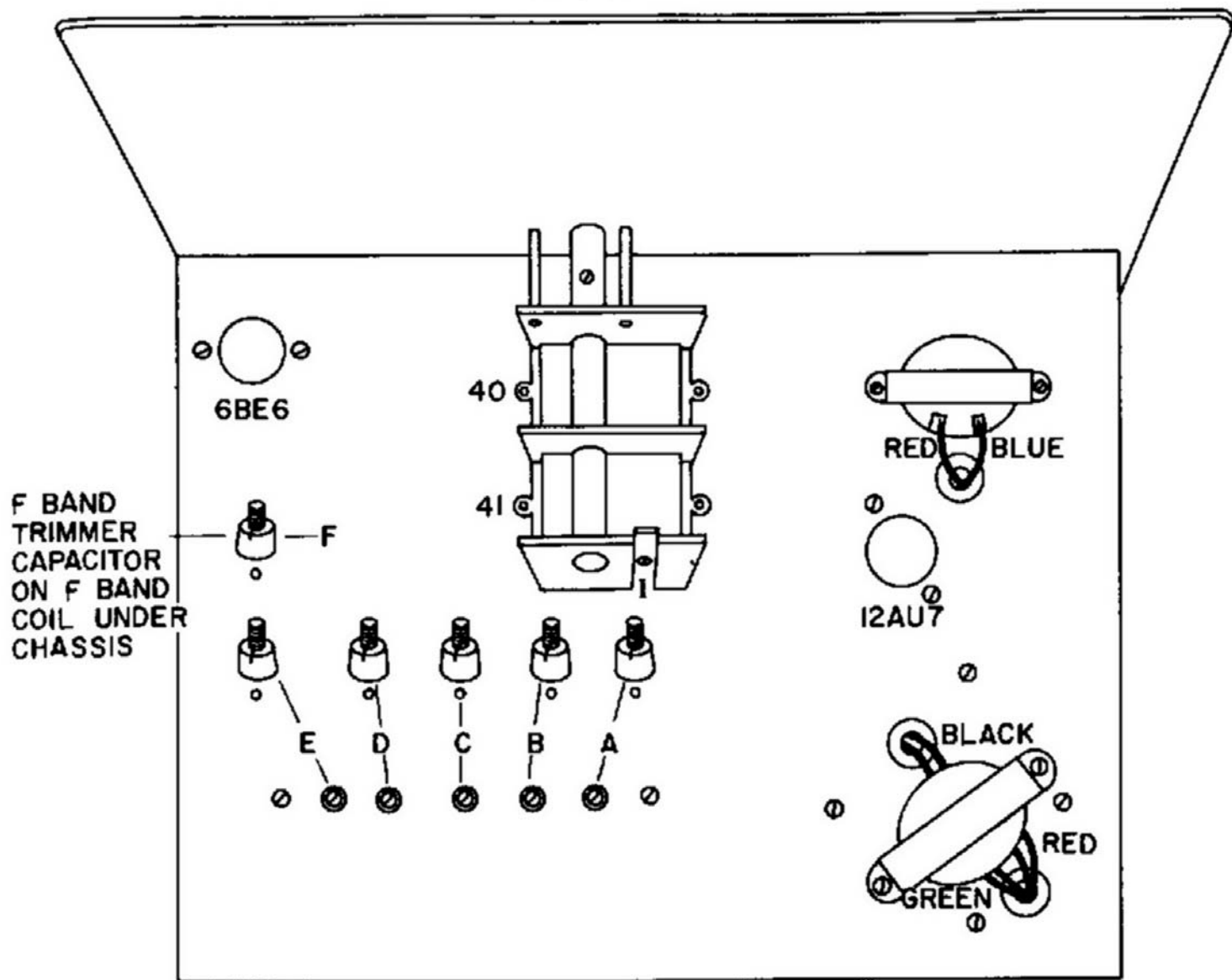

Fig. 5. Top view of chassis identifying the coil and capacitor adjustment for each frequency hand.

	PIN → MODE	1	2	3	4	5	6	7	8	9
V1 6 B E 6	MOD	*-3.4 VDC	*-3.4 VDC	6.4 VAC	0	110 VDC	42 VDC	*-3.3 VDC	-	-
	RF	*-3.2 VDC	*-3.2 VDC	6.4 VAC	0	110 VDC	41 VDC	*-6 VDC	-	-
	AUD	-.68 VDC	-.68 VDC	6.4 VAC	0	0	0	0	-	-
V2 1 2 A U 7	MOD	112 VDC	*5 VAC	5.6 VDC	6.4 VAC	6.4 VAC	51 VDC	-6.8 VDC	1.6 VDC	0
	RF	112 VDC	*2 VAC	5.4 VDC	6.4 VAC	6.4 VAC	62 VDC	-6.2 VDC	1.6 VDC	0
	AUD	132 VDC	*3 VAC	6.8 VDC	6.4 VAC	6.4 VAC	60 VDC	-7.4 VDC	1.8 VDC	0

TABLE 1: Voltage Chart for Signal Generator Model 280

Power Supply Rectifier	Input Terminal	Positive Terminal
CR 1	105 VDC	2 VAC 145 VDC

The above voltage readings were taken with respect to the chassis using a VTVM and with the line voltage at 118 VAC. Your readings may vary +/- 20% due to normal parts tolerances.

*Varies with setting of Band Switch.

NOTE: The capacitance of the voltmeter probe may cause the oscillator to drop out of oscillation when the probe is touched to pin 1 of V1. If this happens, the negative voltage across R1 will decrease toward zero.

For taking readings set controls as follows:

High-Low attenuator switch on high.

Attenuator control at 5.

Band switch at A.

Function switch as indicated in Table 1.

IN CASE OF TROUBLE

If your Signal Generator does not work when assembled, look for wiring errors, poor solder connections, and shorts between wiring or from the wiring to the chassis. Check the output cable with an ohmmeter to be sure there are no shorts between the inner and outer conductors due to over-heating during soldering. Use the voltage chart in Table 1 and the schematic diagram in Fig. 1 to isolate the trouble to one section or part of the instrument. If you find a faulty part write us telling the part number and the name of the part. We will furnish a replacement. Do not return the faulty part unless we write and specifically ask you to do so. Do not disassemble the part as this may void the guarantee.

If you cannot locate the trouble yourself, you may use our free CONAR consultation service. Write us a letter describing in detail the trouble you are experiencing. Make a voltage chart giving the readings that you get on your instrument. Try to give us enough information so we can analyze your trouble. We will try to send you the information necessary to get your Signal Generator back into operating condition.

If you cannot get your Signal Generator working yourself, you can return it for repair. If it is necessary to do this, we will make a service charge of \$7.50 plus the cost of any parts that have been damaged due to wiring errors.

If you return the Instrument to us for repair, write us a letter telling us that the instrument is on the way and describe fully the difficulty you are having. Enclose the \$7.50 minimum charge. Send check or money order. Do not send cash. Pack the instrument in a sturdy carton and fill the open spaces with shredded newspaper. Ship the instrument to us by prepaid express or insured parcel post. We will return your instrument express collect or insured parcel post.

ACCURACY AND ALIGNMENT OF THE SIGNAL GENERATOR

A carefully built CONAR Signal Generator will be accurate enough for service work without aligning the instrument. However, you may wish to check the accuracy of your Signal Generator or you may want to realign it to improve its accuracy. The instrument is provided with an oscillator coil adjustment and a trimmer capacitor adjustment for each band. This enables you to adjust the oscillator circuit so that the

generator frequency corresponds exactly to the scale readings. To do this you must have known accurate frequencies available in the frequency band that you are checking or adjusting.

Do not attempt any adjustment on your signal generator until you are sure that the generator is in error. If you attempt to make adjustments without having known accurate frequencies available you will probably decrease its accuracy.

All signal generators are designed as a convenient source of signals at various frequencies. No Signal Generator is designed as a frequency standard. Some expensive signal generators have a frequency accuracy of better than 1%. For service work and receiver alignment, an accuracy within 2 to 3% is considered quite satisfactory. Your CONAR Signal Generator will probably fall well within this accuracy without alignment. Careful alignment can bring the accuracy to about 1%.

The B band on your Signal Generator can be readily checked or aligned by using the signals from local radio stations. You will need a radio receiver and you must know the exact frequency that the stations operate on. Select two stations, one whose frequency is near the high end of the B band and one near the low end of the B band. Before checking or aligning your signal generator, you should perform the following steps:

- () Turn the signal generator on and let it warm up for at least 15 minutes.
- () Make sure that the red line of the dial pointer coincides with the black line on the left (low frequency) edge of the scales when the tuning capacitor is fully meshed (turned maximum counter clockwise). If not, loosen the pointer set screw and reset the pointer.
- () Identify the coil and capacitor adjustment for each band by referring to Fig. 5. We suggest you use pencil or crayon to mark the band letter on top of the chassis between the trimmer hole and its associated coil. This will help prevent you from accidentally turning a wrong adjustment.

Tune the radio to receive the known frequency station near the high end of the B band. Definitely identify the station. Position the output lead of the signal generator near the radio receiver antenna. Set the signal generator function switch to RF and the

band selector to B. Rotate the signal generator dial to the same frequency as the received radio station. You should hear a high pitched audio signal that decreases in pitch as you approach the frequency. This beat note signal is the difference in frequency between the radio station signal and the generator signal. Zero beat the two signals by carefully adjusting the signal generator frequency until the beat note is at minimum or zero frequency. Now the signal generator is producing exactly the same frequency as the radio station. Observe the dial reading of your signal generator. The difference between the dial reading and the known frequency of the radio station is the error of your signal generator at that frequency.

() Carefully recheck your work to be sure that the error exists. If you decide to try to realign the B band proceed as follows: Locate the trimmer adjustment for band B. Set the signal generator dial to read exactly the frequency of the radio station to which the radio is tuned. Rotate the B band trimmer adjustment until you again hear the beat signal. Then carefully rock the adjustment back and forth to zero beat signal. The signal generator is now correctly aligned at this frequency.

() Tune the radio to a known frequency station whose frequency is near the lower end of the B band. Rotate the dial of the signal generator to indicate about the same frequency as the radio station and zero beat the signals. The difference between the reading on the signal generator and the known frequency of the radio station is the instrument error at this frequency.

() Correct the generator error at the low end of the B band by adjusting the B band coil slug. Set the signal generator to read the known frequency of the radio station that the radio receiver is tuned to. Rotate the B band coil slug adjustment until you hear the beat note and then carefully rock the slug to zero beat the signal.

() After adjusting the slug at the low end of the band you will have to readjust the trimmer at the high end of the band. These two adjustments interact so you have to repeat each adjustment several times.

After aligning the B band at the high end and the low end, the instrument should read correctly at all points on the B band scale. However, some small errors may exist at other points on the B band scale. Such errors are usually due to slightly bent plates on the tuning capacitor resulting from rough handling. Before attempting to correct these errors, you might consider whether they are large enough to worry about. For

example, suppose your signal generator reads 1020 kc when you zero beat it with a station broadcasting exactly 1000 kc. Your signal generator reads one whole graduation above 1000 kc. However, the error is only 2%. That is $1000 \text{ kc} \times .02 = 20,000 \text{ cps}$ or 20 kc. While 20 kc may seem like a large error, it is only 2% of 1000 kc. This size error is unimportant for servicing and aligning a radio receiver.

You can check or align the other bands of your signal generator if you have a Communication Receiver available. As described for Band B, you select stations of known frequencies at both ends of the band you are checking. Use the proper band trimmer to correct errors at the high end of the band and use the corresponding coil slug adjustment to correct errors at the low end of the band.

Harmonics of the signal generator output can be used for checking or aligning. For example, suppose you are receiving a known frequency radio station at 600 kc. Set the signal generator at 300 kc on the A band. The second harmonic of the 300 kc signal is 600 kc. This second harmonic will be received along with the radio station and the signals can be zero beat. Using this technique you can check many additional points on your instrument.

If you prefer, you can send the instrument to us for alignment. For this service there will be a charge of \$7.50. If you send us your completed signal generator for alignment, write us that the instrument is on the way and include the service charge. Send check or money order. Do not send cash. Pack and ship the instrument in accordance with the instructions given in this manual under "In Case of Trouble."

INSTALLING THE SIGNAL GENERATOR IN ITS CABINET

After you have checked the operation of the signal generator, install the chassis in the cabinet. Set the chassis upright in front of the cabinet. Place the power cord from the inside of the cabinet through the hole in the rear of the cabinet. Pull the power cord as you lift up the chassis and push it into the cabinet. Be careful not to catch the switches on the cabinet lip because the switches may get damaged.

Fasten the front panel to the cabinet using six No. 6 self tapping Phillips nickel plated screws. Insert two No. 6, 1/2" slotted hex head self tapping screws through the holes in the bottom of the cabinet into the

matching holes in the chassis. Tighten the screws firmly.

CORRECTIVE MAINTENANCE

Your CONAR Signal Generator is constructed of quality parts and the instrument will ordinarily give years of trouble-free service before any maintenance is required. If trouble develops, service the instrument as you would any other piece of electronic equipment. Since tubes are the most likely cause of failure, test the tubes first. Remove the chassis from the cabinet and test the tubes in a tube tester.

CAUTION: Dangerous voltages are present in this instrument. When you energize the instrument with the chassis out of the cabinet, take precaution to avoid electrical shock.

If you replace the 6BE6 oscillator tube you will want to check the alignment of your Signal Generator. Normal manufacturing tolerances of vacuum tubes causes each 6BE6 tube to operate slightly differently in the signal generator circuit. Most replacement tubes will not cause enough change in the frequency of the output of your Signal Generator to require alignment adjustments. However, it is wise to check the alignment to be sure that the replacement has not seriously changed the output frequency. You will find instructions for checking and alignment under the heading of "Accuracy and Alignment of the Signal Generator" in this manual.

You can check the voltage readings in your Signal Generator against those given in the voltage chart in Table I. Use Fig. 1 to locate test points. This will often lead you to the defective component. Normal parts value tolerances can cause quite large variations in the actual readings from the readings given in the table. If your instrument has been in service for many years, a very low B+ voltage may be caused by a defective selenium rectifier. A large ripple voltage at the output of the power supply may be caused by a defective electrolytic filter capacitor.

Hard usage of the output cable can cause a short circuit in the coaxial cable. Frequent bending of the cable may have caused the braided shield to fray. If these frayed wires of the shield come in contact with the center wire, it will short circuit the output of the signal generator. This condition can be quickly checked by using an ohmmeter. Connect the ohmmeter between the ground lead and the "hot" lead of the output cable. The ohmmeter should read near

infinite resistance. A zero reading or a reading of only a few ohms indicates that there is a short circuit in the cable.

If your instrument does not operate after replacing a defective tube, check the circuitry around that tube. A shorted tube may have caused excessive current to flow through a resistor. The excess current may have caused a resistor to burn out or change value. Use an ohmmeter to check the values of resistors that could have been affected.

If your Signal Generator operates intermittently on some ranges, check the switches for dirty contacts. They can be cleaned by using any good switch contact cleaner.

If your Signal Generator develops a trouble that you cannot locate, use the free CONAR consultation service. Write us a letter explaining the exact nature of your trouble. Include the results of any tests that you have conducted in trying to locate the trouble. Make a voltage chart giving the readings that you get on your instrument. Try to give us enough information so we can analyze your trouble. We will try to send you the information necessary to get your Signal Generator back into operation.

If, after the warranty period has expired, a defect develops in your instrument that you are unable to repair yourself, you may return it for repair for which there is a minimum charge of \$7.50 plus the cost of any parts. This minimum charge is necessary to cover the cost of handling, inspecting, and making minor repairs. If you return the instrument to us for repair, write us a letter telling us that the instrument is on the way and describe fully the difficulty you are having. Enclose the \$7.50 minimum charge. Send check or money order. Do not send cash. Pack the instrument in a sturdy carton and fill the open spaces with shredded newspaper. Ship the instrument to us by prepaid express or insured parcel post. We will return your instrument express collect or insured parcel post.

PARTS LIST

<u>Quan.</u>	<u>Part No.</u>	<u>Schematic Symbol</u>	<u>Description</u>	<u>Price Each</u>
CAPACITORS				
1	CN32	C9	47-mmfd ceramic	.15
1	CN81	C8	100-mmfd ceramic	.15
1	CN39	C10	.002-mfd disc	.15
1	CN35	C11	.005-mfd disc	.15
1	CN8	C13	.05-mfd tubular	.15
1	CN7	C15	.03-mfd tubular	.27
3	CN86	C14,C16 C17	.01-mfd disc	.18
1	CN12	C12	.1-mfd tubular	.18
1	CN155	C18A, C18B	50-30-mfd elect.	1.24
1	CN115	C7	Tuning capacitor	1.90
1	CN144	C1, C2, C3	3-30-mmfd trimmer	1.50
1	CN145	C6	4.5-25-mmfd F band trimmer	.95
COILS				
1	CO1	L7	Audio choke coil	1.10
1	CO69	L1	Band A (brown dot)	.52
1	CO70	L2	Band B (red dot)	.50
1	CO71	L3	Band C (orange dot)	.48
1	CO72	L4	Band D (yellow dot)	.48
1	CO73	L5	Band E (green dot)	.52
1	CO74	L6	Band F (blue dot)	.68
HARDWARE				
1	CL3		Clip, Alligator (black)	.14
1	CL25		Clip, Alligator (red)	.13
4	GR1		Rubber grommet	12/.25
2	HA5		3/8" metal spacer	.08
1	HA23		10' roll rosin-core solder	.16
4	LU5		Small solder lug	12/.15
1	SO14		7-pin tube socket	.15
1	SO15		9-pin tube socket	.20
3	WA14		Flat metal washer	12/.15
14	WA15		No. 6 split-ring lockwasher	12/.15
2	WA16		No. 8 split-ring lockwasher	12/.15
MISCELLANEOUS				
1	CA15		39" output cable	.52
1	CB4		Cabinet	6.76
1	CH47		Chassis	1.20
1	DA10		Dial pointer assembly	1.62
1	IN19		1" plastic tubing	.13
1	KN8		Tuning knob	.25
3	KN12		Black bar knob	.17
4	NU5		4-40 hex nut	12/.15
7	NU1		6-32 hex nut	12/.15
2	NU3		8-32 hex nut	12/.15
1	PA13		Panel	3.55
1	PC1	P1	Power cord	.40

PARTS LIST(CONT.)

Quan.	Part No.	Schematic Symbol	Description	Price Each
1	PO47	R11, S2	3K-ohm pot. and on-off switch with nut and control lockwasher	.85
1	SR10	CR1	Selenium rectifier	.55
1	SW28	S1	Band switch with nut	2.10
1	SW29	S3	Function switch with nut and control lockwasher	.94
1	SW30	S4	High-Low attenuator switch	.21
1	TR22A	T1	Power transformer	2.36
1	TU15	V2	12AU7 tube	1.28
1	TU17	V1	6BE6 tube	1.20
RESISTORS				
(All resistors are 10%, 1/2-watt unless otherwise specified)				
1	RE72	R12	47-ohm, 1/2-watt	.15
1	RE28	R10	470-ohm, 1/2-watt	.15
1	RE111	R8	1.2K-ohm, 1/2-watt	.15
1	RE29	R2	4.7K-ohm, 1/2-watt	.15
2	RE33	R1, R3	22K-ohm, 1/2-watt	.15
2	RE35	R6, R7	47K-ohm, 1/2-watt	.15
3	RE36	R4, R5, R9	100K-ohm, 1/2-watt	.15
1	RS70	R13	3.3K-ohm, 1-watt	.18
SCREWS				
4	SC6		1/4", 4-40	12/.15
8	SC1		1/4", 6-32	12/.15
2	SC43		1/4", 8-32	12/.15
2	SC45		1/2", No. 6, self-tapping	12/.25
6	SC46		1/2", No. 6 self-tapping	12/.25
2	SC48		1/4", 6-32 Phillips	12/.25
2	SC47		9/16", 6-32	12/.25
TERMINAL STRIPS				
1	ST4		6-lug, both end lugs grounded	.14
1	ST13		2-lug, right lug grounded	.04
1	ST15		4-lug, right lug grounded	.10
1	ST18		1-lug, mounting foot on right insulated	.05
1	ST28		4-lug, left lug grounded	.09
WIRE				
1	WR47		4' roll green wire	*
1	WR48		1' roll orange wire	*
1	WR61		3' roll brown wire	*
1	WR72		3' roll blue wire	*
1	WR76		3' roll bare wire	.12
1	WR80		2-1/2' roll red wire	*
1	WR88		6" length black wire	.12

*All additional wire in 12' lengths only 25 cents each color.

RESISTOR AND CAPACITOR COLOR CODES

JAN and EIA stand for the two common color codes (Joint Army-Navy and Electronics Industries Association). The two codes are the same except as indicated. We have not indicated temperature coefficients or characteristics of capacitors, because they are not necessary for identifying your parts.

COLOR	SIG. FIG.	MULTIPLIER	RESIS.	TOLERANCE			PAPER CAP
				CERAMIC CAPACITORS 10 MMF OR LESS	OVER 10 MMF	MICA CAPACITORS (As below, or ± 1 mmf, whichever is larger)	
Black	0	1		± 2.0 MMF	$\pm 20\%$	$\pm 20\%$	20%
Brown	1	10		± 1.0 MMF	$\pm 1\%$	$\pm 1\%$	
Red	2	100			$\pm 2\%$	$\pm 2\%$	
Orange	3	1000			$\pm 2.5\%$	$\pm 2.5\%$	
Yellow	4	10,000					
Green	5	100,000		± 0.5 MMF	$\pm 5\%$	$\pm 5\%$ (EIA)	5%
Blue	6	1,000,000					
Violet	7	10,000,000					
Gray	5			± 0.25 MMF			
White	9			± 1.0 MMF	$\pm 10\%$		10%
Gold		.1	$\pm 5\%$			5% (JAN)	5%
Silver		.01	$\pm 10\%$			10%	10%
No color			$\pm 20\%$				20%

RESISTORS — RESISTANCE GIVEN IN OHMS

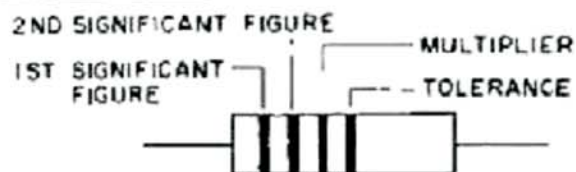

Black body = composition, non-insulated.
 Colored body = composition, insulated.
 Double width band for 1st sig. figure indicates wire-wound.

CAPACITORS — CAPACITY GIVEN IN MMF

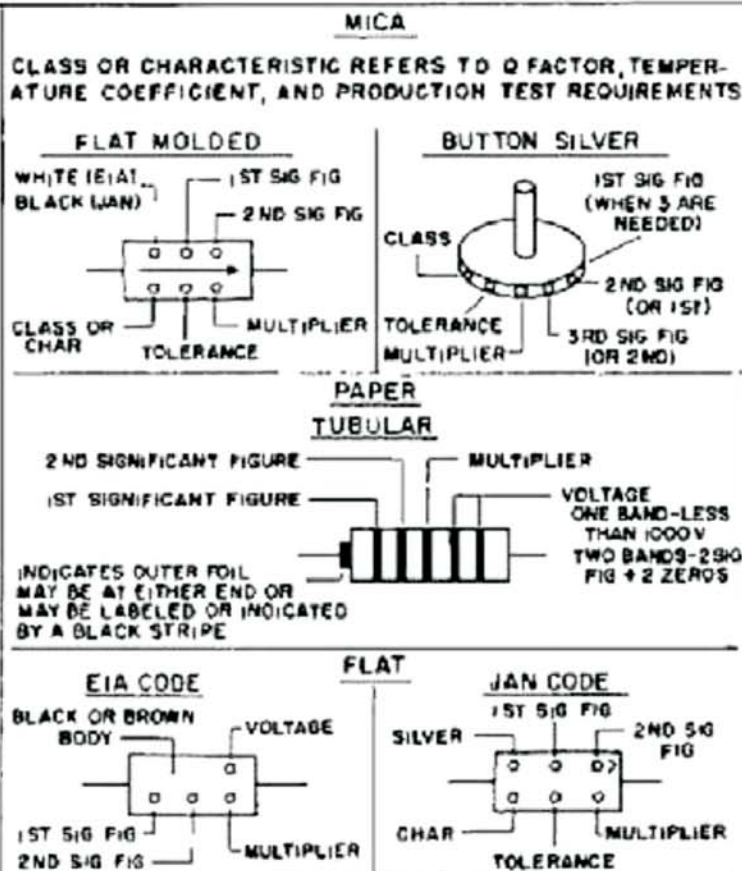
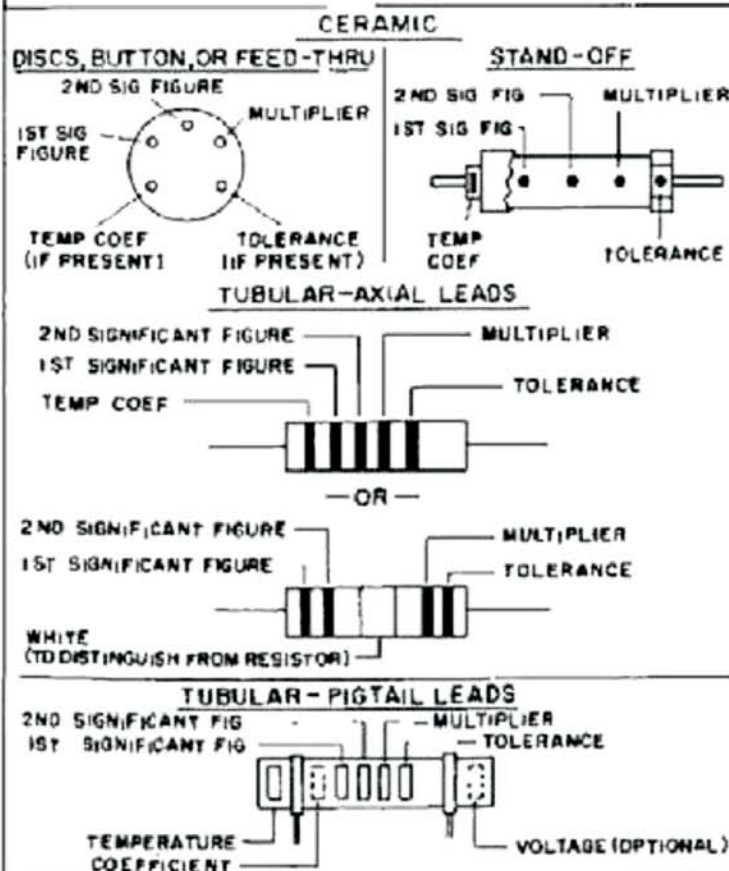

Dear Customer

No matter what your experience has been with equipment, there's a new and even greater satisfaction awaiting you in this CONAR product.

CONAR is a division of the National Radio Institute - a pioneer of more than 50 years in the Electronics field. True, age alone is seldom a compliment. Yet there is no substitute for the priceless ingredient of experience. Intelligent design and engineering, clear-cut instructions written for the user, top-grade components are your assurance you have made a wise choice - a sound dollar investment.

The purpose of this book is to tell you how to get maximum value from this CONAR product. Please read these instructions carefully and follow them faithfully. Then you can rely on the dependable service of CONAR quality.

We reserve the right to make changes in design or improvement when such changes or improvements represent an equal or greater value to our customers.

WARRANTY

All CONAR products are guaranteed against factory defects for ONE FULL YEAR. Any part or component that becomes defective and such defect is not the result of accidental damage, improper use or wiring errors, will be replaced when returned to CONAR.

There are four conditions under which you may have to write us about this CONAR product:

(1) It arrives damaged. We ship some items by parcel post, others by express. In a parcel post shipment, if any part is broken on arrival, we will replace it without charge, if you return it to us. However, for damage in express shipments, the Railway Express Agency is responsible. If you find any damage in an express shipment, contact the Express Agency and ask for an Inspection Report. They will fill out the report and give you a copy, which you are to send to us. We cannot replace damaged parts until we receive this report.

(2) Parts are missing. If anything is missing, and you find no substitute or other instructions after carefully examining the packing for small items, write us a letter explaining.

(3) A part has a defect. DEFECTIVE MATERIAL MUST BE RETURNED BEFORE A REPLACEMENT CAN BE MADE. TWO THINGS MUST BE WITH EVERY PACKAGE YOU RETURN TO US: (1) Your name and address, (2) Your reason for returning it. You may enclose a letter in the package, if you mark the package "first class letter enclosed". Such a package requires a stamp in addition to the regular parcel post charge. Unless examination shows an obvious defect, write first, and tell us why you think the part is defective. Some other part may be causing the trouble.

(4) You lose or damage parts. Parts listed in this manual may be ordered directly from CONAR, 3939 Wisconsin Ave., Washington, D.C., 20016. When ordering parts, please be sure to give the following information:

1. The part number.
2. The part name.
3. The type and model number of the product in which the part is used.

CONAR INSTRUMENTS DIVISION OF NATIONAL RADIO INSTITUTE, WASHINGTON, D.C. 20016

COPYRIGHT 1968 BY NATIONAL RADIO INSTITUTE, WASHINGTON, D.C. 20016