

PRICE \$2.00

Assembling and Using your

CONAR

Signal Tracer

Model 230

QUALITY EQUIPMENT BUILT ON A HALF CENTURY OF SERVICE IN ELECTRONICS

ASSEMBLING THE CONAR MODEL 230 TUNED SIGNAL TRACER

If you have purchased your signal tracer already assembled, turn to page 20 for instructions on operating it.

With a tuned signal tracer you can sample the signal at any point in a radio receiver using either transistors or tubes, or in any audio amplifier. With the signal tracer you can hear how the signal sounds, and thus locate distortion, intermittent reception, hum, and any other type of interference. The signal tracer also measures the amplitude of signals so you can tell accurately the gain or loss in signal strength in any stage. This signal tracer can be used as a tuned radio-frequency receiver for receiving radio stations in the broadcast band.

Take the necessary time to do a really good job of assembling your signal tracer. If you build your signal tracer exactly as instructed in this manual you will have an extremely valuable service instrument.

We have put the diagrams that you will keep referring to on sheets stapled into the center of this manual, so that you can remove them and have them handy to refer to. Carefully open the staples and remove the top two sheets, then close the staples firmly again.

CHECKING YOUR PARTS

Check the parts you have received against the photo in Fig. 1 and the list under the photo. If any part appears to be missing, look for a substitute. If you find no substitute or if any part is damaged in shipment, follow the instructions on the inside of the cover, for obtaining a replacement. After you have checked all the parts, read the following assembly hints before starting to build the signal tracer.

ASSEMBLY HINTS

1. Follow the instructions. Follow the step-by-step instructions given. Check off each step as soon as you finish it, by placing a check mark in the parentheses provided. Don't attempt to skip around or leave out any steps, or to build from the schematic diagram, even though you may be entirely capable of doing so.

The holes in the chassis are identified in Fig. 3, and the holes in the panel in Fig. 4. In Fig. 5 all the terminals have been numbered, so you can find them easily as you follow the instructions. Do not mount these parts until you are told to do so.

2. Do a first-class soldering job. Use a clean, hot iron at all times. Be sure to apply enough heat to avoid rosin joints. The solder should melt when you touch it to the wires of the joint. If you buy more solder locally, make certain the box is marked RADIO ROSIN-CORE SOLDER. 60/40 solder is satisfactory. Do NOT USE ACID-CORE SOLDER OR PASTE FLUX. If you use either of these, you will ruin your signal tracer beyond repair.

Soldering should be no problem if you use a small pencil iron (between 37 and 65 watts). The object of the small iron is not to keep the heat at a low value, but to make it easy to get the iron tip into tight corners. A larger soldering iron can, of course, also be used.

Pre-tinning of leads makes soldering easy. Just pass the lead back and forth over the iron tip while allowing a little solder to melt on the tip. This gives a thin solder coating on the lead, and solder will "take" easily when you make connections in the circuit. In general, this treatment is required only on resistor leads.

When soldering near the coils, do not let the soldering iron tip or barrel touch these coils, or they may be damaged. In most cases not more than three leads are soldered to a single terminal. This makes it easy to get the solder to "take" not only on the terminals, but also on all leads. If there are more than three leads attached to a lug, it may be necessary to turn the work so that the iron tip can be held against the bottom lead. After the soldered joint has cooled, wiggle each wire. If the wire moves in the joint when wiggled, re-solder it, let it cool, and check again.

When soldering to the band-switch terminals, set the chassis on its back apron, so that solder will not run down the switch lugs and ruin the contacts. When you have made secure con-

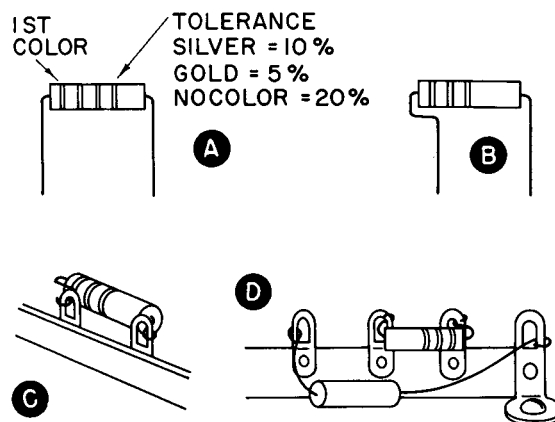

FIG. 2. How to bend resistor leads so the part can be easily mounted.

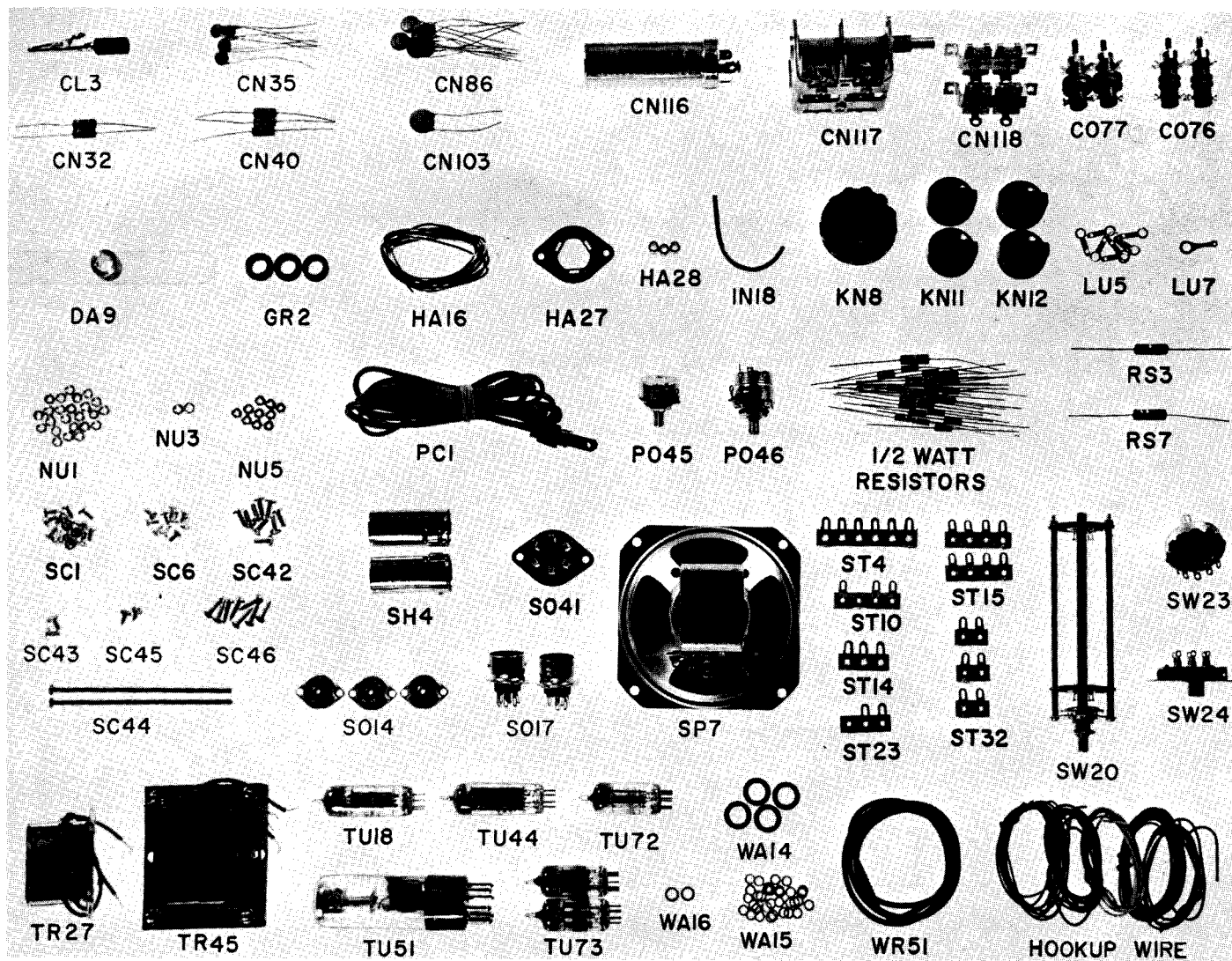

FIG. 1. The parts in this kit are shown above and identified in the list below.

Quan.	Part No.	Description	Quan.	Part No.	Description	Quan.	Part No.	Description
1	CB5	Cabinet (not shown)	1	PO46	3K-ohm pot. and on-off switch with nut and lockwasher	1	SP7	Loudspeaker
1	CH45	Chassis (not shown)	1	PR3	Assembled probe (not shown)	1	ST4	6-lug terminal strip
1	CL3	Clip, Alligator	1	RE19	510-ohm, 1/2 W, 5% resistor	1	ST10	3-lug terminal strip, insulated mtg. foot
2	CN32	47-mmfd capacitor	2	RE26	100-ohm, 1/2 W resistor	1	ST14	3-lug terminal strip, one lug grounded
4	CN35	.005-mfd disc capacitor	2	RE29	4.7K-ohm, 1/2 W resistor	2	ST15	4-lug terminal strip, one lug grounded
3	CN40	270-mmfd ceramic capacitor	1	RE32	18K-ohm, 1/2 W resistor	1	ST23	2-lug terminal strip, insulated mtg. foot
7	CN86	.01-mfd disc capacitor	3	RE36	100K-ohm, 1/2 W resistor	3	ST32	2-lug terminal strip, one lug grounded
1	CN103	.05-mfd disc capacitor	1	RE37	220K-ohm, 1/2 W resistor	1	SW20	Band switch with nut
1	CN116	30-30 mfd electrolytic capacitor	2	RE38	470K-ohm, 1/2 W resistor	1	SW23	5-pos. rotary switch, with nut and lockwasher
1	CN117	Tuning capacitor	2	RE39	1-meg, 1/2 W resistor	1	SW24	DPDT slide switch
2	CN118	Dual trimmer capacitor	1	RE42	10-meg, 1/2 W resistor	1	TR27	Output transformer
2	CO76	Band B coil	1	RE55	3.3-meg, 1/2 W resistor	1	TR45	Power transformer
2	CO77	Band A coil	4	RE68	150K-ohm, 1/2 W resistor	1	TU18	6AQ5 tube
1	DA9	Dial pointer	1	RE72	47-ohm, 1/2 W resistor	2	TU44	6X4 tube
3	GR2	Rubber grommet	1	RE137	5.1K-ohm, 5%, 1/2 W resistor	1	TU51	6E5 tube
1	HA9	Speaker grille (not shown)	1	RE138	51-ohm, 5%, 1/2 W resistor	1	TU72	6AV6 tube
1	HA16	5' roll rosin-core solder	1	RE139	.56-ohm, 1/2 W resistor	1	TU73	6GM6 tube
1	HA27	Metal mtg. wafer for electrolytic capacitor	1	RE140	330-ohm, 1/2 W resistor	4	WA14	Flat metal washer
3	HA28	1/4" metal spacer	1	RE141	5.1-ohm, 5%, 1/2 W resistor	34	WA15	No. 6 split-ring lockwasher
2	HA45	1" metal spacer (not shown)	1	RS3	390-ohm, 1 W resistor	2	WA16	No. 8 split-ring lockwasher
1	IN18	4" varnished cambric spaghetti	1	RS7	1K-ohm, 1 W resistor	1	WR50	2-ft. roll blue wire
1	KN8	Tuning knob	14	SC1	1/4", 6-32 screw	1	WR51	36" black flexible wire
2	KN11	Red bar knob	10	SC6	1/4", 4-40 screw	1	WR71	6-ft. roll green wire
2	KN12	Black bar knob	9	SC42	3/8", 6-32 screw	1	WR78	5-ft. roll black wire
8	LU5	Small solder lug	2	SC43	1/4", 8-32 screw	1	WR82	3-ft. roll yellow wire
1	LU7	Large solder lug	2	SC44	4", 6-32 screw	1	WR85	7" length purple wire
24	NU1	6-32 hex nut	2	SC45	1/4", No. 6, self-tapping screw	1	WR87	5-ft. roll red wire
2	NU3	8-32 hex nut	8	SC46	1/2", No. 6, self-tapping screw			
10	NU5	4-40 hex nut	2	SH4	Miniature tube shield			
1	PA11	Panel (not shown)	3	SO14	7-pin tube socket, unshielded			
1	PC1	Power cord	1	SO41	6-pin tube socket			
1	PO45	500K-ohm pot. with nut and lockwasher	2	SO17	7-pin tube socket with shield base			

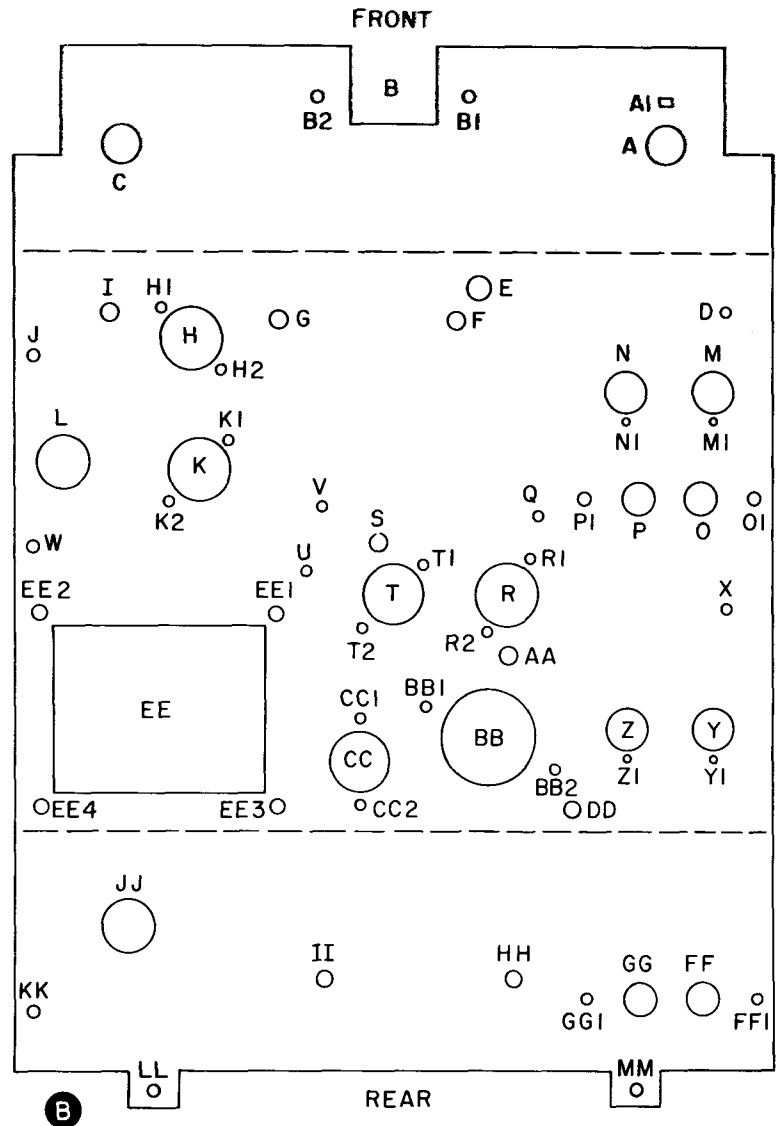
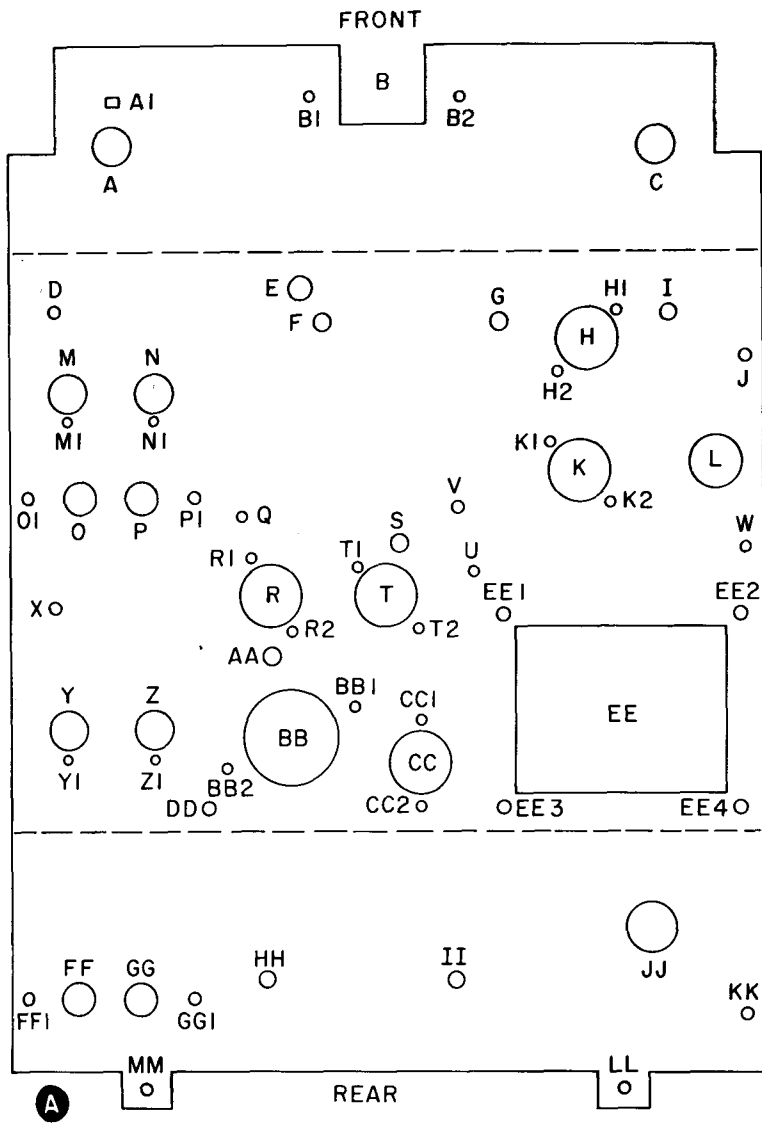

FIG. 3. Upper and lower views of chassis with holes identified.

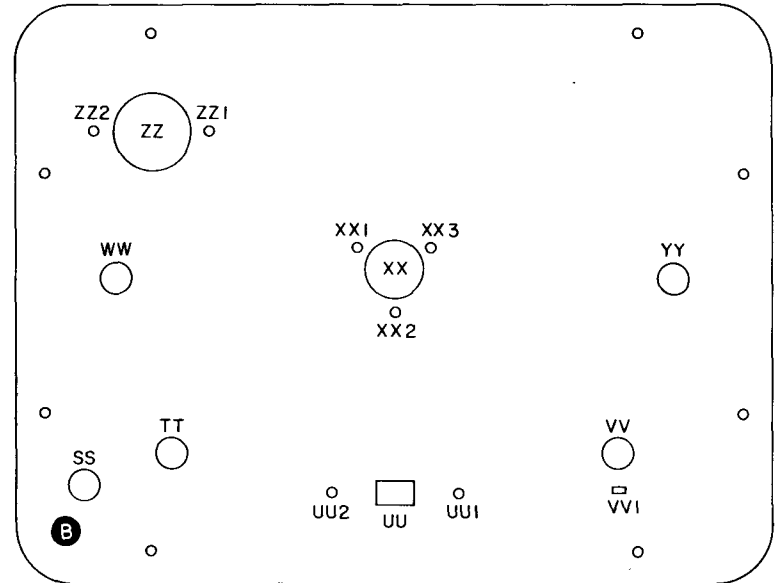
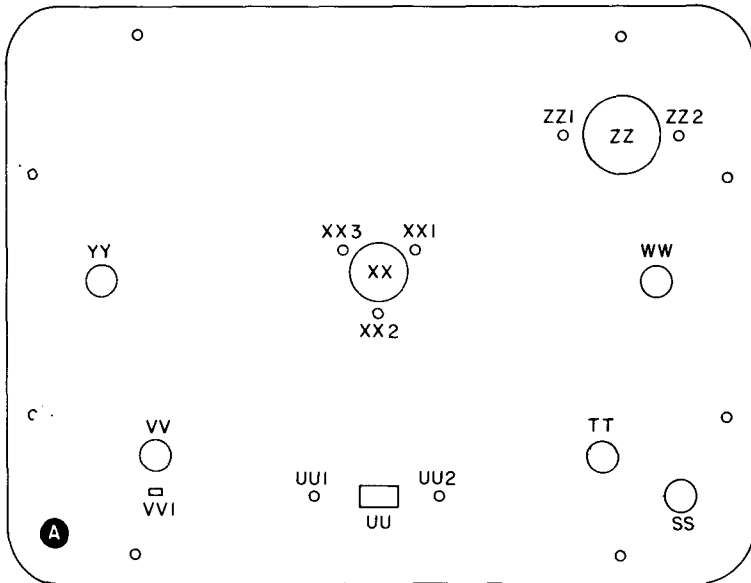

FIG. 4. Front and back views of panel with holes identified.

nections to a point, clip off all excess lead lengths.

3. Be sure to position all parts and wires as shown in the illustrations. All leads are to be short, with the parts and leads positioned as shown. Improper positioning of leads and parts can result in oscillation. Space is limited, but by following the directions all the way through the manual, you will have no trouble. In many cases resistors are to be mounted on adjacent lugs of a terminal strip. To get a neat fit, bend the resistor leads at right angles to the body of the resistor as shown in Fig. 2A. Next, bend the lead nearest the first color-code band back along the resistor body as far as the first band close to the body of the resistor, and then straight down as shown in Fig. 2B, using your fingers. The spacing between the resistor leads will be exactly right to fit into the holes in the terminal strip lugs, as shown in Fig. 2C. Do not grasp or squeeze the resistor body with pliers, as this will break the resistor.

The color codes for identifying the values of resistors and capacitors are shown inside the back cover of this manual.

When connecting resistors and capacitors, position them as shown, push the leads through the terminals, and make a hook joint. Then cut off any excess lead length. Resistors are 1/2 watt, unless otherwise specified.

Be sure to use the length of wire specified in each case. When you are stripping insulation from the ends of hook-up wire, it is seldom necessary to take off more than 1/4", unless the end goes through one terminal to another one. If you remove too much insulation you may cause shorts to other wires or parts. Excess lead length between the part and soldered connections may result in short circuits. On the other hand, do not pull insulated leads so tight that sharp edges of chassis holes will cut through the insulation and produce shorts. In some cases insulation known as spaghetti is slipped over part leads to avoid a short-circuit. You will be instructed when to use it.

When a lockwasher is used, it is to be directly under the nut unless otherwise indicated. When tightening nuts over lockwashers, tighten the nut until the lockwasher is squeezed closed. The spring tension of the lockwasher will then prevent the nut from backing off.

WIRING THE ATTENUATOR SWITCH

To make the wiring of the attenuator switch easier, you will wire the switch before mounting it. In this way, you can work out in the open instead of in a tight corner under the chassis. You will use the chassis as a convenient mount to hold the switch upright while you work on it. You will need the following parts:

- One chassis.
- One rubber grommet.
- One attenuator switch (5-position rotary switch).
- One 5.1K-ohm resistor (green-brown-red-gold).
- One 510-ohm resistor (green-brown-brown-gold).
- One 51-ohm resistor (green-brown-black-gold).
- One 5.1-ohm resistor (green-brown-gold-gold).
- One .56-ohm resistor (green-blue-silver-gold).

When you have gathered these parts together, proceed with the following steps, using Figs. 3 and 6 as a guide. Before performing a step, read through the entire step to be sure you understand it. Check off each step as soon as you finish it, so you won't skip any. Do not solder until you are told to do so.

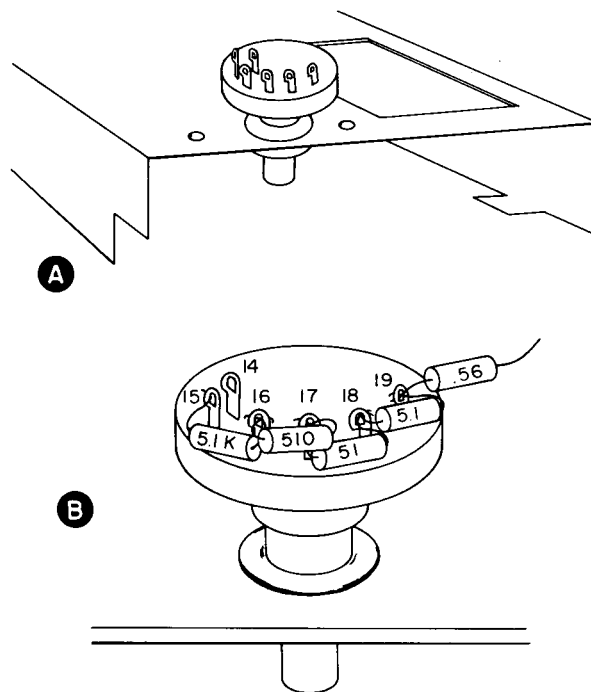

FIG. 6. How to wire the attenuator switch.

- () Install a rubber grommet in hole L in the chassis. To install a grommet, squeeze the grommet between your thumb and forefinger, and force the grommet part-way through the chassis hole. Continue working the grommet into the hole until it is completely in place. Lift up the grommet lips on both sides of the chassis until the lips lie flat.
- () Insert the shaft of the attenuator switch through the grommet in hole L, from the top of the chassis. Force the threaded portion of the switch far enough into the grommet to hold the switch

in place. Fig. 6A shows the position of the switch on the upright chassis.

- (2) Connect a 5.1K-ohm resistor (green-brown-red-gold) between terminals 15 and 16. Keep the leads short, and position the resistor as shown in Fig. 6B.
- (-) Connect a 510-ohm resistor (green-brown-brown-gold) between terminals 16 and 17.
- (4) Connect a 51-ohm resistor (green-brown-black-gold) between terminals 17 and 18.
- (4) Connect a 5.1-ohm resistor (green-brown-gold-gold) between terminals 18 and 19.
- (2) Space a .56-ohm resistor (green-blue-silver-gold) 1/2" from terminal 19 and connect it to terminal 19. Leave the other end free.
- (4) Carefully recheck your work. Make sure that the resistors are connected as shown in Fig. 6B. Now solder connections 16, 17, 18, and 19. Do not solder terminal 15, because another lead will be connected to this terminal later.
- (1) This completes the wiring of the attenuator switch. Remove the switch from the grommet, and set the wired switch to one side. Leave the grommet installed in hole L.

MOUNTING HARDWARE ON THE CHASSIS

The next thing you are to do is to mount many of the parts on the chassis. You can identify these parts from Fig. 1. You will need the following:

- One chassis (with grommet in hole L).
- One rubber grommet.
- Two band-B coils (small).
- Two band-A coils (large).
- Two 7-pin miniature sockets with shield bases.
- Three unshielded 7-pin miniature tube sockets.
- Ten 4-40 screws.
- Ten 4-40 nuts.
- Twenty-four No. 6 split-ring lockwashers.
- Seven small solder lugs.
- Fourteen 6-32 screws.
- Fourteen 6-32 nuts.
- One 6-lug terminal strip.
- Two 4-lug terminal strips.
- One 3-lug terminal strip with one lug grounded.
- One 3-lug terminal strip with insulated mounting foot.
- Three 2-lug terminal strips with one lug grounded.
- One 2-lug terminal strip with insulated mounting foot.
- Two dual trimmer capacitors.
- One power transformer.
- One metal wafer for mounting electrolytic capacitor.
- One 30-30 mfd electrolytic capacitor.

When you are counting the solder lugs, be sure not to take the one that is larger than the others. Set it aside for use later. When you have gathered these parts together, proceed with the following steps, using Figs. 3, 4, 5, 7, and 8. Before performing a step, read through the entire step to be sure you understand it. Check off each step as soon as you finish it so you won't skip any.

- (4) Mount a rubber grommet in chassis hole JJ.

Next you are to mount the coils. The slugs in them have been preset to make alignment easy, so do not move the slug adjustments. There are four coils in this kit. The two larger coils are for band A, and the two smaller are for band B. When installing the coils, insert the metal cap through the proper hole from the bottom of the chassis, with the coil turned so that the positioning tip fits into the small adjacent hole. Use your thumbs to press the coil into place, pressing straight down

on the cardboard coil form. Be careful not to use too much side pressure or the coil form may break. Press firmly on the coil end of the form until the clips on the metal cap pass through the chassis, and both of them click into place. Now, following these instructions, proceed as follows:

- (↪) Mount a band-B (small) coil in hole Z, with the positioning tip in hole Z1.
- (↪) Mount a band-A (large) coil in hole Y, with the positioning tip in hole Y1.
- (↪) Mount a band-A (large) coil in hole N, with the positioning tip in hole N1.
- (↪) Mount a band-B (small) coil in hole M, with the positioning tip in hole M1.

Now mount the following parts, inserting the screws from the top of the chassis, and positioning the parts as shown in Figs. 5 and 7. In each case, the lockwasher goes directly under the nut.

- (↪) Shielded 7-pin miniature socket in hole H from top of chassis, with tube socket pins positioned as shown for V_2 in Fig. 7. Use 4-40 screws and nuts and No. 6 lockwashers in holes H1 and H2. Put a solder lug on the screw in hole H2 before putting on a lockwasher and nut.
- (↪) Shielded 7-pin miniature socket in hole R from the top of the chassis, with tube socket pins positioned as shown for V_3 in Fig. 7. Use 4-40 screws and nuts, and No. 6 lockwashers in holes R1 and R2, with a solder lug on the screw in hole R1.
- (↪) Unshielded 7-pin miniature socket in hole T from the bottom of the chassis, with the socket pins positioned as shown for V_5 in Fig. 7. Use 4-40 screws and nuts, and No. 6 lockwashers, and a solder lug on the screw in hole T1.
- (↪) Unshielded 7-pin miniature socket in hole K from the bottom of the chassis, with the socket pins positioned as for V_7 in Fig. 7. Use 4-40 screws and nuts and No. 6 lockwashers, and a solder lug on the screw in hole K1.
- (↪) Unshielded 7-pin miniature socket in hole CC from the bottom of the chassis, with the socket pins positioned as for V_4 in Fig. 7. Use 4-40 screws and nuts and No. 6 lockwashers.
- (↪) Three-lug terminal strip with one grounded lug (terminals 39 and 40), on bottom of chassis over hole J. Use a 6-32 screw and nut and No. 6 lockwasher.
- (↪) Two-lug terminal strip with insulated mounting foot (terminals 41 and 42) on bottom of chassis over hole W. Use a 6-32 screw and nut and No. 6 lockwasher.
- (↪) Solder lug (terminal 83) on top of chassis over hole V. Use a 6-32 screw. Put a 4-lug terminal strip (terminals 33-36) on the same screw on the bottom of the chassis. Put on a lockwasher and a 6-32 nut.
- (↪) Two-lug terminal strip with one lug grounded (terminals 29 and 30) over hole Q on the bottom of the chassis. Use a 6-32 screw and nut and a No. 6 lockwasher.
- (↪) Four-lug terminal strip (terminals 43-45) over hole X on the bottom of the chassis. Use a 6-32 screw and nut and a No. 6 lockwasher.
- (↪) Two-lug terminal strip with one lug grounded (terminals 89 and 90) over hole D on top of the chassis. Use a 6-32 screw and nut and a No. 6 lockwasher.
- (↪) Dual trimmer capacitor on bottom of chassis over holes O and P. Notice that on one side of the dual capacitor, each terminal is connected to a narrow metal piece, and on the other side, each terminal is connected to a wider metal piece. Be sure to mount the capacitor so that the wider metal pieces are toward the 4-lug strip. Use 6-32 screws, nuts, and No. 6 lockwashers in holes P1 and O1, with a solder lug (terminal 26) on the screw in hole O1, between the chassis and the mounting bracket of the capacitor.

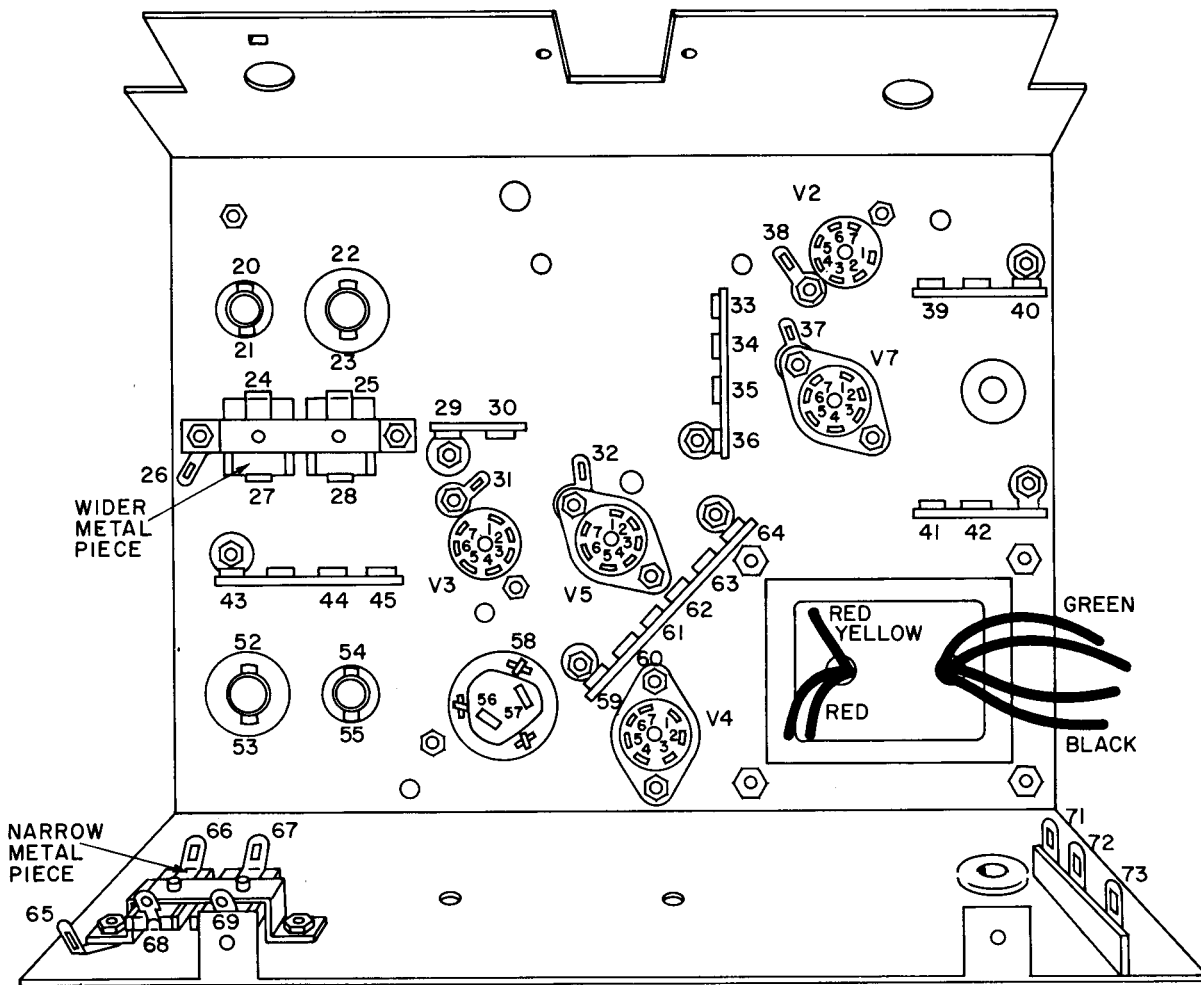

FIG. 7. Parts mounted on the bottom of the chassis.

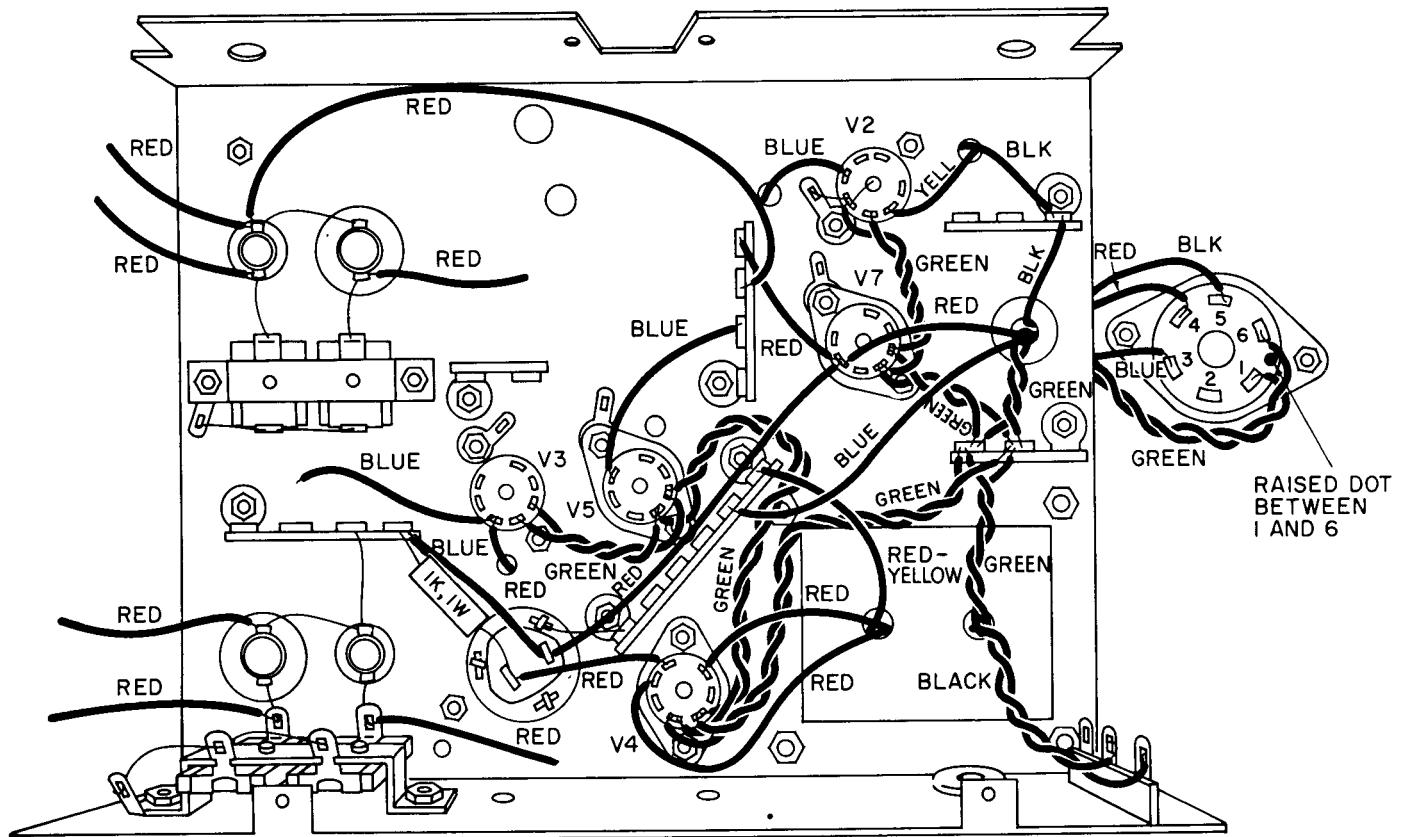

FIG. 9. Preliminary wiring under the chassis.

- (✓) Power transformer on top of chassis over hole EE. First remove the four nuts and lockwashers from the assembly screws. Position the transformer so that its black and green leads are near the edge of the chassis, as in Fig. 7. Pass the transformer assembly screws through holes EE1, EE2, EE3, and EE4. Put on the lockwashers and the nuts you previously removed. Draw the nuts up tight.
- (✓) Three-lug terminal strip with insulated mounting foot (terminals 71-73) over hole KK from the bottom of the chassis. Use a 6-32 screw and nut and a No. 6 lockwasher.
- (✓) Dual trimmer capacitor from the bottom of the chassis over holes FF and GG, with wider metal pieces toward the edge of the chassis. Use 6-32 screws and nuts and No. 6 lockwashers in holes GG1 and FF1, with a solder lug (terminal 65) on the screw in hole FF1, between the chassis and the capacitor mounting bracket.
- () Mounting wafer for electrolytic capacitor on top of chassis over hole BB. Position it as in Fig. 7 and detail drawing of Fig. 8. Insert a 6-32 screw through a two-lug terminal strip (terminals 84 and 85), then through hole BB2 from the top of the chassis. Put on a No. 6 lockwasher and a 6-32 nut. Insert a 6-32 screw through hole BB1 from the top of the chassis. Put one foot of a 6-lug terminal strip (terminals 59 through 64) on this same screw on the bottom of the chassis, then a lockwasher and nut. Be sure the 6-lug strip is positioned as in Fig. 7.

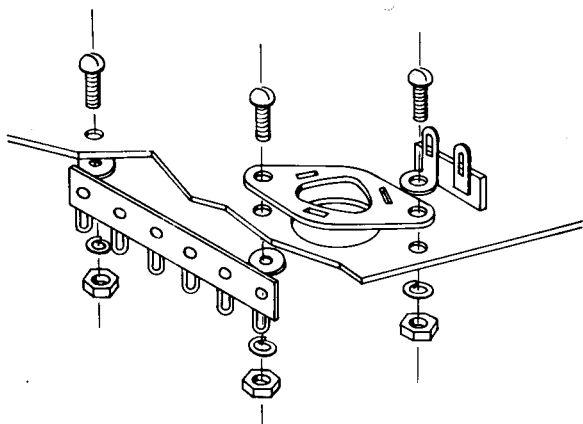

FIG. 8. How to mount the mounting wafer for the electrolytic capacitor. The two-lug terminal strip goes above the chassis, and the six-lug terminal strip beneath the chassis.

- (✓) Mount the other end of the 6-lug strip over hole U, using a 6-32 screw, nut, and a No. 6 lockwasher.
- (✓) Insert the lugs of the electrolytic capacitor through the slots in the mounting wafer, with terminals 56 and 57 positioned as shown in Fig. 7. Using a pair of pliers, twist each of the capacitor mounting lugs a quarter of a turn to hold the capacitor firmly in the mounting wafer.

This completes the mounting of hardware at this time. Check your chassis to see that it has the parts mounted and positioned as shown in Fig. 7.

WIRING THE CHASSIS

You are now ready to begin wiring your instrument. Read through each step before starting it, to be sure you understand it. Check off each step as soon as you finish it.

Be sure to use the specified length of hookup wire when given. If the length is not specified, use the shortest length that will reach between the connection points. When installing a piece of wire, remove about one-quarter of an inch of insulation from each end, bend a hook in the bare end, insert the end into the hole or around the lead or lugs specified, and pinch the hook shut with your long-nose pliers. Cut off any excess lead. In some cases you will be instructed to solder the joint immediately; in others, you will not solder until later. In the latter case, it is important to pinch the hook tight to hold the wire in place until it is soldered. If the end of a wire goes through one terminal to another, the lead between the two terminals must, of course, be stripped.

The first wiring you are to do is shown in Fig. 9. You will need the following parts :

- One 1K-ohm, 1-watt resistor (brown, black, red).
- One 6-pin socket.
- Assorted hookup wire.
- One 3/4-inch piece of spaghetti.

Before starting on the wiring, twist up a length of green hookup wire for the filament wiring. To do so, double your green wire and twist it to form a twisted pair. You can then cut off lengths of it as needed. Notice that the filament leads are to be down against the chassis to prevent induction from them to other leads. Any wires that cross the filament wires are to be routed over the top of the filament wires. Try to position the leads exactly as shown, as this will avoid instability and feedback.

The leads of the power transformer are made up of stranded wire. Be careful not to break off any of the strands when stripping the ends of the leads. Before starting, twist the black transformer leads loosely together, and the green transformer leads loosely together.

The 6-pin socket is V_6 in the signal tracer. Put the socket alongside the chassis near hole L. In the wiring instructions you will be told to connect wires to this socket. The socket will hang loose above the chassis. You will be given instructions on mounting it later on in the manual. Now go ahead with the following instructions.

- (✓) Cut off 3" of the twisted green pair. Connect one wire at one end to pin 3 of V_2 . Run the other wire at the same end through pin 4 of V_2 , and to the center shield. Solder pin 3.
- (✓) Connect the wires at the other end of this same twisted pair to pins 3 and 4 of V_7 . Do not solder either one yet.
- (✓) Connect one end of a 2-1/2" piece of the green pair to pins 3 and 4 of V_7 , and solder both pins.
- (✓) Connect the other ends of the above to terminals 41 and 42. Do not solder.
- (✓) Connect one green lead of the power transformer to terminal 41. Do not solder.
- (✓) Connect the other green lead of the power transformer to terminal 42. Do not solder.
- (✓) Connect the wires at one end of a 6" piece of the green pair to terminals 41 and 42. Do not solder.
- (✓) Connect the other ends of the above to pins 3 and 4 of V_4 . Do not solder.
- (✓) Connect the wires at one end of a 7" piece of the green pair to pins 3 and 4 of V_4 , and solder both pins.
- (✓) Connect the other ends of the above to pins 3 and 4 of V_5 . Do not solder.
- (✓) Connect the wires at one end of a 3" piece of the green pair to pins 3 and 4 of V_5 , and solder both pins.
- (✓) Connect the other ends of the above to pins 3 and 4 of V_3 , and solder both pins.
- (✓) Connect the wires at one end of a 6-1/4" piece of the green pair to pins 1 and 6 of V_6 (the unmounted tube socket), and solder both connections.
- (✓) Bring the other end of the above through the grommet in hole L, and connect them to terminals 41 and 42. Do not solder.
- () Connect one red lead of the power transformer to pin 6 of V_4 . Solder pin 6.
- () Connect the other red lead of the power transformer to pin 1 of V_4 . Solder pin 1.
- () Connect the red-yellow lead of the power transformer to terminal 64. Do not solder.

- (✓) Connect one black lead of the power transformer to terminal 72. Do not solder.
- (✓) Connect the other black lead of the power transformer to terminal 73. Do not solder.
- (✓) Connect a 2" piece of red wire between pin 7 of V_4 and terminal 56. Solder pin 7.
- (✓) Connect a 1K-ohm, 1-watt resistor between terminals 56 and 45. Do not solder.
- (✓) Connect a 2-1/2" piece of red wire between terminals 45 and 57. Do not solder.
- (✓) Connect a 1" piece of bare wire between terminal 58 and 59. Solder both.
- (✓) Connect a 4" piece of red wire between terminals 57 and 6 of V_7 . Solder 57.
- (✓) Connect a 1-3/4" piece of red wire between pin 6 of V_7 and terminal 33. Do not solder.
- (✓) Connect one end of an 8-1/2" piece of red wire to terminal 34. Do not solder. Run the other end over to terminal 22. Strip off 1-1/2" of insulation and run the bare end through terminal 22 to terminal 20. Solder 22.
- (✓) Run one end of a 2-1/2" piece of red wire with 3/4" of insulation removed through terminal 21 to terminal 24. Solder 21 and 24. Leave the other end of the wire free at this time.
- (✓) Run one end of a 2-1/2" piece of red wire with 3/4" of insulation removed through terminal 23 to terminal 25. Solder 23 and 25. Leave the other end of the wire free.
- (✓) Connect one end of a 1-1/2" piece of red wire to terminal 20. Solder 20. Leave the other end of the wire free.
- (✓) Connect one end of a 1-1/2" piece of blue wire to pin 5 of V_2 . Push the other end through hole G, but do not connect it yet. Solder pin 5 of V_2 .
- (✓) Connect one end of a 3" piece of yellow wire to pin 2 of V_2 , and solder it. Push the other end through hole I.
- (✓) Connect one end of a 2-3/4" piece of black wire to terminal 40. Do not solder. Push the other end through hole I.
- (✓) Connect a 2-1/2" piece of blue wire between pin 7 of V_5 and terminal 35. Solder pin 7 of V_5 .
- (✓) Connect one end of a 6-1/2" piece of red wire to pin 4 of V_6 . Do not solder. Run the other end through the grommet in hole L and connect it to pin 6 of V_7 . Do not solder.
- (✓) Run one end of a 2-1/2" piece of red wire with 1" of insulation removed through terminal 66 to terminal 53. Solder both. Leave the other end of the wire free.
- (✓) Run one end of a 2-1/2" piece of red wire with 1" of insulation removed through terminal 67 to terminal 55. Solder both. Leave the other end of the wire free.
- (✓) Run one end of a 3-1/2" piece of red wire with 2-1/2" of insulation removed through terminal 52 and terminal 54 and over to terminal 44. Solder 52 and 54. Leave the other end of the wire free.
- (✓) Run a 2" piece of bare wire from terminal 28 through 27 to 26, and solder all three.
- (✓) Run a 2" piece of bare wire from terminal 69 through 68 to 65, and solder all three.
- (✓) Connect one end of a 4" piece of blue wire to pin 5 of V_3 . Do not solder. Push the other end of the wire through hole AA.
- (✓) Connect one end of a 2" piece of blue wire to pin 5 of V_3 . Do not solder. Leave the other end of the wire free.

- (✓) Connect a 3/4" piece of bare wire between pin 4 of V_2 and terminal 38. Solder pin 4.
- (✓) Connect one end of an 8-1/2" piece of blue wire to pin 3 of V_6 , and solder it. Run the other end of the wire through the grommet in hole L, and connect it to terminal 63. Do not solder.
- () Connect one end of a 6" piece of black wire to pin 5 of V_6 and solder it. Run the other end through the grommet in hole L. Connect it to terminal 40. Do not solder.

The next wiring you are to do is shown in Fig. 10. You will need the following parts:

Two 100-ohm resistors (brown-black-brown).
 Two 470K-ohm resistors (yellow-violet-yellow).
 Two 150K-ohm resistors (brown-green-yellow).
 Five .01-mfd disc capacitors.
 Two 270-mmf capacitors.
 Two 4.7K-ohm resistors (yellow-violet-red).
 Two .005-mfd disc capacitors.
 One 220K-ohm resistor (red-red-yellow).
 One 390-ohm, 1-watt resistor (orange-white-brown).
 One .05-mfd disc capacitor.
 One 3.3-megohm resistor (orange-orange-green).
 One 100K-ohm resistor (brown-black-yellow).
 Two 47-mmf capacitors.
 One 1-megohm resistor (brown-black-green).
 One 330-ohm resistor (orange-orange-brown).
 One 10-megohm resistor (brown-black-blue).
 Assorted hookup wire.

When you have gathered these parts, proceed with the following instructions.

- (✓) Connect a 100-ohm resistor between pin 1 of V_2 and terminal 39. Solder 1 of V_2 .
- (✓) Connect one lead of a 470K-ohm resistor to terminal 39. Do not solder. Run the other lead through the center shield of V_2 and over to pin 7 of V_2 . Solder pin 7 and the center shield.
- (✓) Connect a 150K-ohm resistor between pin 6 of V_2 and terminal 33. Do not solder.
- (✓) Connect a .01-mfd disc capacitor between pin 6 of V_2 and terminal 38. Solder both terminals.
- (✓) Connect a 270-mmf capacitor between pin 1 of V_7 and terminal 37. Do not solder.
- (✓) Connect a .01-mfd disc capacitor between terminals 34 and 36. Do not solder.
- (✓) Connect a 4.7K-ohm resistor between terminal 33 and 34. Solder 34.
- (✓) Connect a 470K-ohm resistor between pin 1 of V_7 and terminal 37. Solder both.
- (✓) Connect a .005-mfd disc capacitor between terminal 35 and pin 7 of V_7 . Solder pin 7.
- (✓) Connect a 220K-ohm resistor between terminal 35 and pin 6 of V_7 . Solder 35.
- (✓) Connect .005-mfd disc capacitor between pin 5 of V_7 and terminal 36. Solder terminal 36.
- (✓) Connect a 390-ohm, 1-watt resistor between pin 2 of V_7 and terminal 40. Solder pin 2.
- (✓) Connect a .05-mfd disc capacitor between terminals 63 and 64. Do not solder.
- (✓) Connect a 3.3-meg resistor between terminals 62 and 63. Solder terminal 63.
- (✓) Connect a 270-mmf capacitor between terminals 62 and 64. Solder 64.

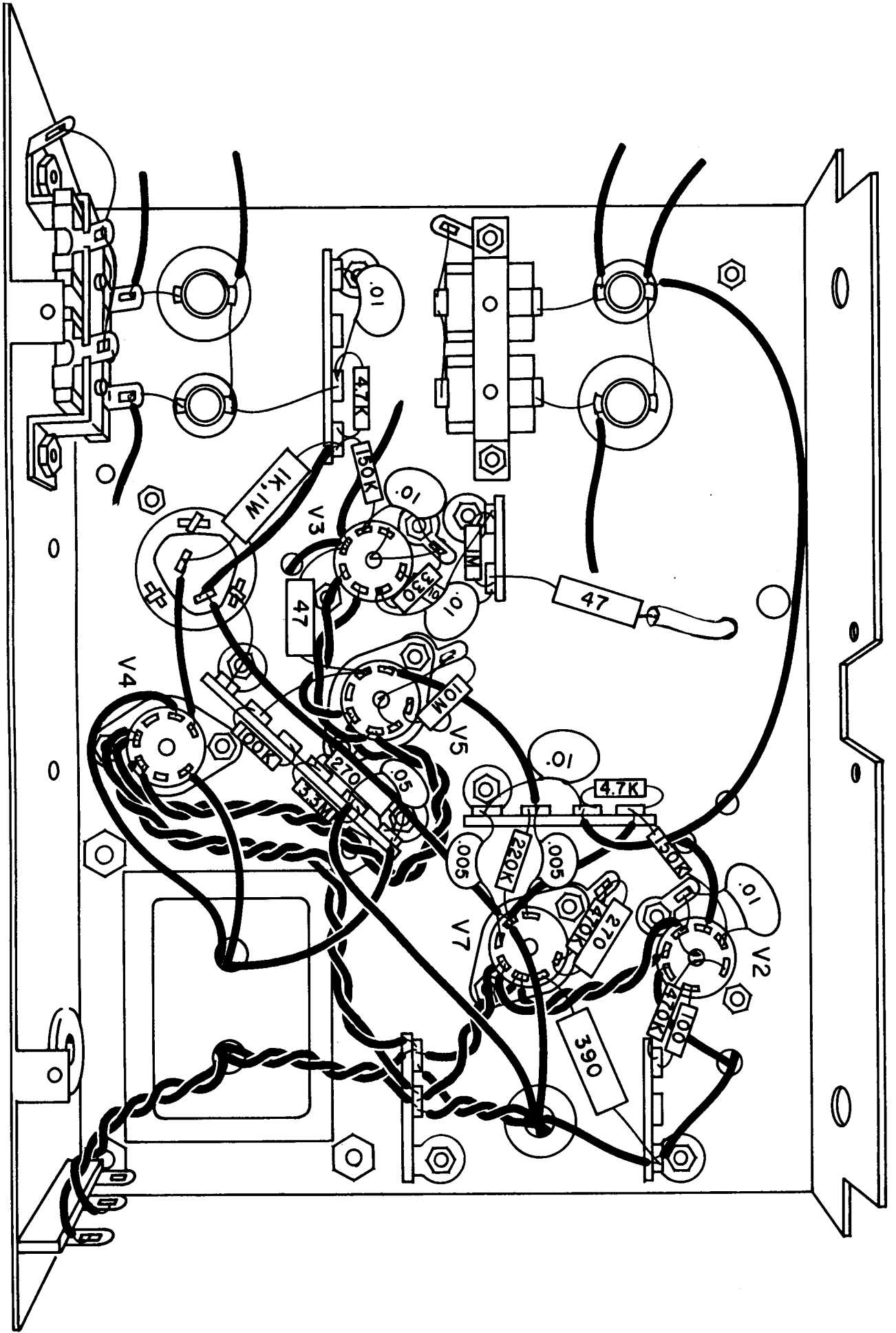

FIG. 10. Under view of chassis with further wiring added.

- (X) Connect a 100K-ohm resistor between terminals 61 and 60. Do not solder.
- (✓) Connect a 1-3/8" bare wire between terminals 60 and 6 of V₅. Solder 60.
- (✓) Connect a 47-mmf capacitor between pin 6 of V₅ and pin 5 of V₃. Solder both terminals.
- (✓) Connect a .01-mfd disc capacitor between terminals 43 and 44. Solder 43.
- (✓) Connect a 150K-ohm resistor between terminal 45 and pin 6 of V₃. Do not solder.
- (✓) Connect one lead of a .01-mfd disc capacitor to pin 6 of V₃. Run the other lead through terminal 31 and over to the center shield of V₃. Solder pin 6.
- (✓) Connect a piece of bare wire between pin 7 and the center shield of V₃. Solder both.
- (✓) Connect a 1-meg resistor between terminals 29 and 30. Do not solder.
- (✓) Connect a 100-ohm resistor between terminal 30 and pin 1 of V₃. Solder pin 1.
- (✓) Connect a 330-ohm resistor between pin 2 of V₃ and terminal 31. Solder 31.
- (✓) Connect a 4.7K-ohm resistor between terminals 44 and 45. Solder 44 and 45.
- (✓) Put a 3/4" piece of spaghetti on one lead of a 47-mmf capacitor. Make a right-angle bend in the spaghetti-covered lead, 1/2 inch from the body of the capacitor. Push this lead up through hole F from the bottom of the chassis.
- (✓) Connect the other lead of the 47-mmf capacitor to terminal 30. Solder the connection.
- (✓) Connect one lead of a 10-meg resistor to pin 1 of V₅. Run the other lead through terminal 32 and over to the center shield of V₅. Solder 32.
- (✓) Connect a piece of bare wire between the center shield and pin 2 of V₅. Solder both connections.
- (✓) Connect a .01-mfd disc capacitor between pin 2 of V₃ and terminal 29. Solder both terminals.

Recheck your wiring carefully with Fig. 10, and position all parts as shown. Be sure that the leads of various parts do not short to each other. Check the lead of the 150K-ohm resistor connected to pin 6 of V₂. It must not touch pin 5 of V₂ or the lead connected to it.

ATTACHING PANEL TO CHASSIS AND MOUNTING ADDITIONAL PARTS

Before proceeding further with the wiring, you are to attach the front panel to the chassis by mounting the attenuator switch, slide switch, and band switch. You will also mount most of the other parts. You will need the following:

- One front panel.
- One two-gang tuning capacitor.
- Three 1/4" hollow metal spacers.
- Five 3/8", 6-32 screws.
- One attenuator switch (previously wired with resistors).
- Three control lockwashers.
- Four flat control washers.
- Four control nuts.
- One double-pole, double-throw slide switch.
- Two 6-32 nuts.
- One small solder lug.
- One large solder lug.

Two No. 6 lockwashers.
 One rubber grommet.
 One 500,000-ohm volume control.
 One 3K-ohm fine-attenuator control and on-off switch.
 One band switch.
 One output transformer.
 Two 1/4-inch, 8-32 flat-head screws.
 Two 8-32 nuts.
 Two No. 8 lockwashers.

In doing the following work, refer to Figs. 3, 4, 5, 11, and 12. Keep the movable plates of the tuning capacitor meshed with the stationary ones during assembly of the signal tracer to prevent damage to the plates.

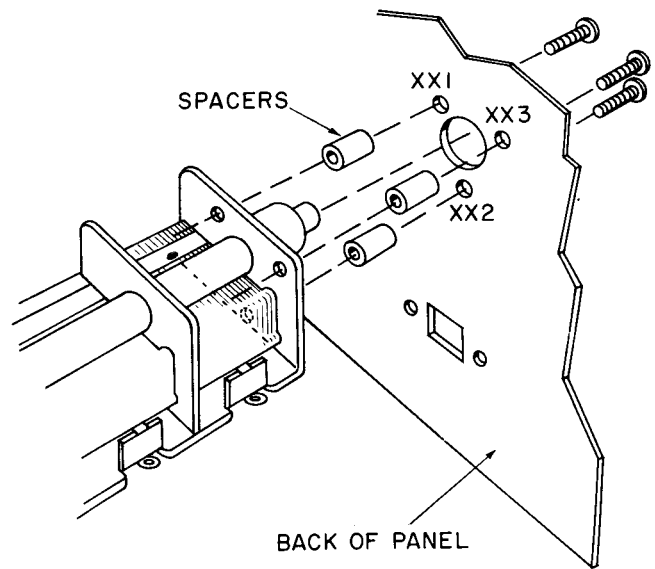

FIG. 11. Mounting the tuning capacitor.

- (1) Mount the tuning capacitor on the back of the front panel at hole XX by placing the hollow metal spacers between panel holes XX1, XX2, XX3, and the corresponding tapped holes in the front of the tuning capacitor, as shown in Fig. 11. Put 3/8", 6-32 screws through the panel holes and hollow spacers and into the tuning capacitor to hold it in place. Tighten the screws firmly.
- (2) Place the panel against the front of the chassis. Turn the shaft of the attenuator switch that you previously wired to its center position. Insert the switch shaft through a control lockwasher, and through hole C from the bottom of the chassis, and then through corresponding hole TT of the front panel. Rotate the switch in its mounting hole until the flat side of the shaft is toward the bottom of the panel. Put on the flat washer and the nut, drawing it up securely.
- (3) Connect the free end of the .56-ohm resistor (green-blue-silver-gold) to terminal 40. Do not solder.
- (4) Mount the slide switch over cut-out B from the bottom of the chassis, positioned as shown in Fig. 5A. Insert a 3/8" 6-32 screw through hole B1 from the front of the panel. Put on a No. 6 lockwasher and a 6-32 nut. Insert another 3/8" 6-32 screw through hole B2. Put on a small solder lug (terminal 13), a No. 6 lockwasher, and a 6-32 nut, and tighten both nuts securely.
- (5) Install a rubber grommet in panel hole SS.
- (6) Put the shaft of the 500,000-ohm (1/2-meg) volume control through a lockwasher and then through hole YY from the rear of the front panel, positioning its lugs as shown in Fig. 5B. Put on a flat control washer, and attach the nut, drawing it up securely.
- (7) Put the shaft of the fine attenuator control and on-off switch through a control lockwasher and through hole WW from the rear of the front panel, with the lugs positioned as shown in Fig. 5B. Put on a flat washer and attach a nut, drawing it up tight.
- (8) If there is a lockwasher on the shaft of the band switch, remove and discard it. Then put the shaft through hole A in the chassis and hole VV in the front panel from the bottom, with the lugs positioned as shown in Fig. 5A. Do not hold the switch by its wafers. Work the switch in carefully, so that you do not damage the wafers, any of its lugs, or the coils mounted on the chassis. Be sure the locating lug fits into hole A1 and VV1. Put on a flat control washer, and attach the nut, tightening it firmly. Notice that the switch is somewhat flexible. Therefore, be careful not to twist the rear wafer. The frame of the switch should be parallel with the chassis.
- (9) Mount the output transformer over holes HH and II, from the bottom of the chassis, with the enameled leads toward the edge of the chassis. Use 8-32 screws and nuts and No. 8 lockwashers. Put the larger solder lug (terminal 70) on the screw in hole II, between the chassis and the mounting foot of the transformer.

INSTALLING PROBE, GROUND LEAD, AND POWER CORD

You will need the following parts:

- One probe.
- One alligator clip.
- One 3-ft. black test lead.
- One power cord.
- One 3-inch length of spaghetti.

Now proceed with the following steps, using Figs. 12 and 13 as a guide.

- (1) Insert the probe cable from the front of the panel through the grommet in hole SS. Tie an overhand knot in the cable about 4" from the end. The knot will bear against the panel and relieve any strain on the cable connections.
- (2) Notice that the cable is made up of two pairs of wires, one pair (one black and one white) is inside a braided shield; the other pair (one black and one white) is not shielded. Be sure when you make the connections that you do not get the two pairs mixed up. First, solder the black shielded lead to pin 6 of V_7 .
- (3) Solder the white shielded lead to terminal 15.
- (4) Solder the black unshielded lead to terminal 41.
- (5) Solder the white unshielded lead to terminal 42.
- (6) Solder the braided shield to the center shield of V_2 .
- (7) Strip about 1/2" of insulation from one end of the black test lead. Slip the alligator clip onto this end of the lead, push the bare end of the wire under the small loop in the clip, and solder the connection.
- (8) Insert the other end of the lead through the grommet in hole SS from the outside. Work the lead through beside the probe cable. Tie a knot about 2" from the end of the lead, and pull the knot up against the grommet. Strip off 1/4" of insulation, and solder the lead to terminal 40.
- (9) Insert the end of the power cord through the grommet in hole JJ, from the outside of the chassis. Tie a knot in the cord about 2" from the end. Connect one lead to terminal 71, do not solder.
- (10) Connect the other lead of the power cord to terminal 73, and solder the connection.
- (11) Put a 3" length of spaghetti through hole DD. Thread one enameled lead of the output transformer through the spaghetti and hole DD. Connect this lead to terminal 85 on top of the chassis. Be sure to scrape the enamel from the end of the lead (about 1/4") before making the connection. Do not solder it yet.

You are now ready to proceed with the wiring given in Figs. 12 and 13. You will need the following parts:

- One 270-mmf capacitor.
- One 18K-ohm resistor (brown-gray-orange).
- Two .01-mfd disc capacitors.
- Two .005-mfd disc capacitors.
- One 1-megohm resistor (brown-black-green).
- One 47-ohm resistor (yellow-violet-black).
- Two 150K-ohm resistors (brown-green-yellow).
- Two 100K-ohm resistors (brown-black-yellow).
- Assorted hookup wire.

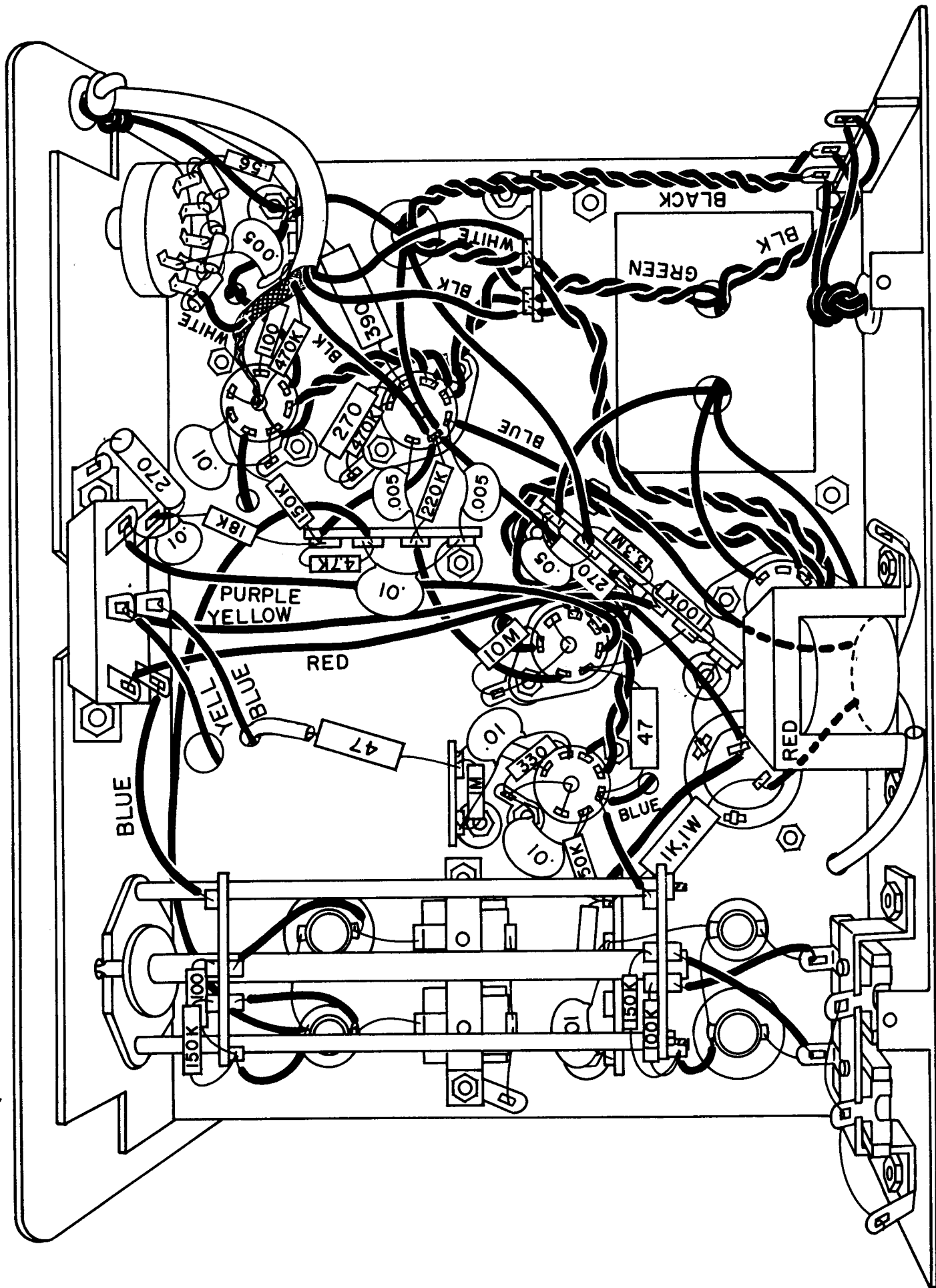
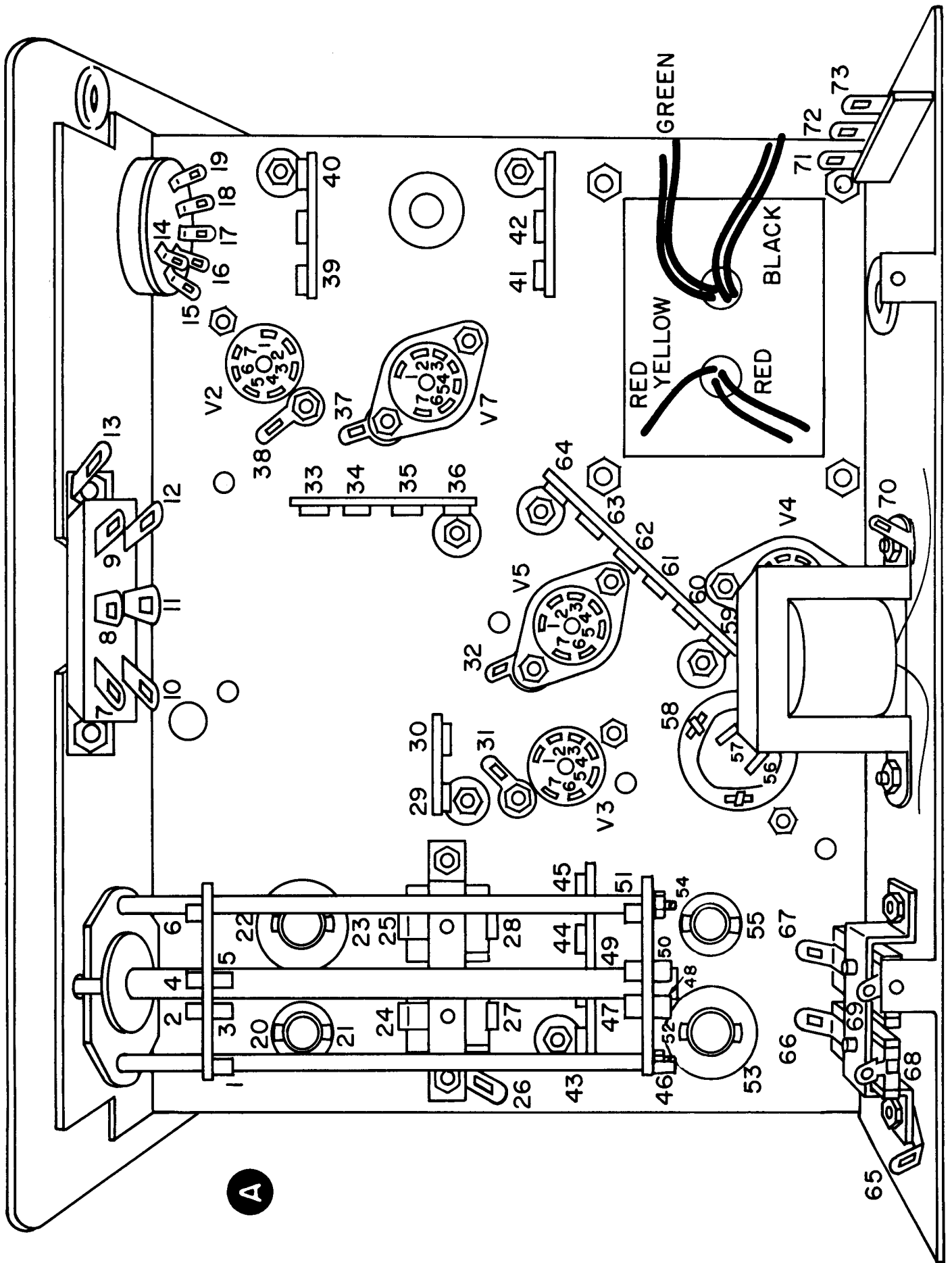

FIG. 12. Final wiring under the chassis.



A

When you have gathered these parts, proceed as follows:

- () Twist two pieces of black wire together to form a 7-1/2" twisted pair. Connect the wires at one end of this twisted pair to terminals 71 and 72, and solder both terminals. Push the other end of the pair through the grommet in hole L.
- () Connect the enameled lead of the output transformer to terminal 70. Solder the connection.
- () Connect the red lead of the output transformer to terminal 56, shorten it if necessary, and solder it.
- () Connect the blue lead of the output transformer to pin 5 of V_7 , and solder it.
- () Connect the free end of the red wire on terminal 21 to terminal 3, and solder terminal 3.
- () Connect the free end of the red wire on terminal 23 to terminal 5, and solder terminal 5.
- () Connect the free end of the red wire on terminal 20 to terminal 1. Do not solder.
- () Connect the free end of the red wire on terminal 67 to terminal 48. Solder 48.
- () Connect the free end of the red wire on terminal 66 to terminal 50. Solder terminal 50.
- () Connect the free end of the red wire on terminal 52 to terminal 46. Do not solder.
- () Connect a 270-mmf capacitor between terminals 12 and 13. Solder 13.
- () Connect an 18K-ohm resistor between terminals 33 and 12. Solder 33.
- () Connect a .01-mfd disc capacitor between terminals 12 and 9. Solder 12.
- () Connect a 6-1/2" length of purple wire between pin 5 of V_5 and terminal 9. Solder both connections.
- () Connect a 5-1/2" length of yellow wire between terminals 62 and 8. Solder 62.
- () Connect a 6-1/2" piece of red wire between terminals 61 and 7. Solder both.
- () Connect a 2-1/4" piece of blue wire to terminal 11. Push the other end of the wire through hole F inside the spaghetti covered lead. Solder terminal 11.
- () Connect a 2-1/2" piece of blue wire between terminals 10 and 6. Solder both.
- () Connect one end of a 5-1/2" piece of yellow wire to terminal 8, and solder it. Push the other end of the wire through hole E.
- () Connect one end of a 6" piece of yellow wire to pin 1 of V_5 , and solder it. Push the other end of the wire through hole S.
- () Connect the blue lead from pin 5 of V_3 to terminal 51, and solder it.
- () Connect a 150K-ohm resistor between terminals 1 and 2. Solder terminal 2.
- () Connect a 100K-ohm resistor between terminals 1 and 4. Solder both.
- () Connect a 100K-ohm resistor between terminals 46 and 49. Solder 49.
- () Connect a 150K-ohm resistor between terminals 46 and 47. Solder both.
- () Connect a .005-mfd disc capacitor between terminal 39 and 14. Solder both.

Now turn the chassis over, and proceed with the following wiring.

- (✓) Connect the black twisted pair from grommet L to terminals 74 and 75, and solder both connections.
- (✓) Connect both the blue wire and the spaghetti covered lead from hole F to terminal 80. Solder the connection.
- (✓) Connect the blue wire from hole G to terminal 79 and solder the connection.
- (✓) Connect the yellow wire from hole E to terminal 86 and solder it.
- (✓) Connect the yellow wire from hole S to terminal 89. Do not solder.
- (✓) Connect a 1" piece of black wire between terminals 88 and 90. Solder both.
- (✓) Connect a .005-mfd disc capacitor between terminals 87 and 89. Solder both.
- () Connect a 1-meg. resistor between pins 2 and 4 of V_e . Solder both.
- (✓) Connect the blue wire from hole AA to terminal 81 and solder it.
- () Connect a 47-ohm resistor between terminals 76 and 77. Solder 77.
- () Connect a .01-mfd disc capacitor between terminals 76 and 78. Do not solder.
- () Connect the yellow wire from hole I to terminal 76, and solder it.
- () Connect the black wire from hole I to terminal 78 and solder it.
- () Connect a 1" piece of bare wire between terminals 82 and 83 and solder both.

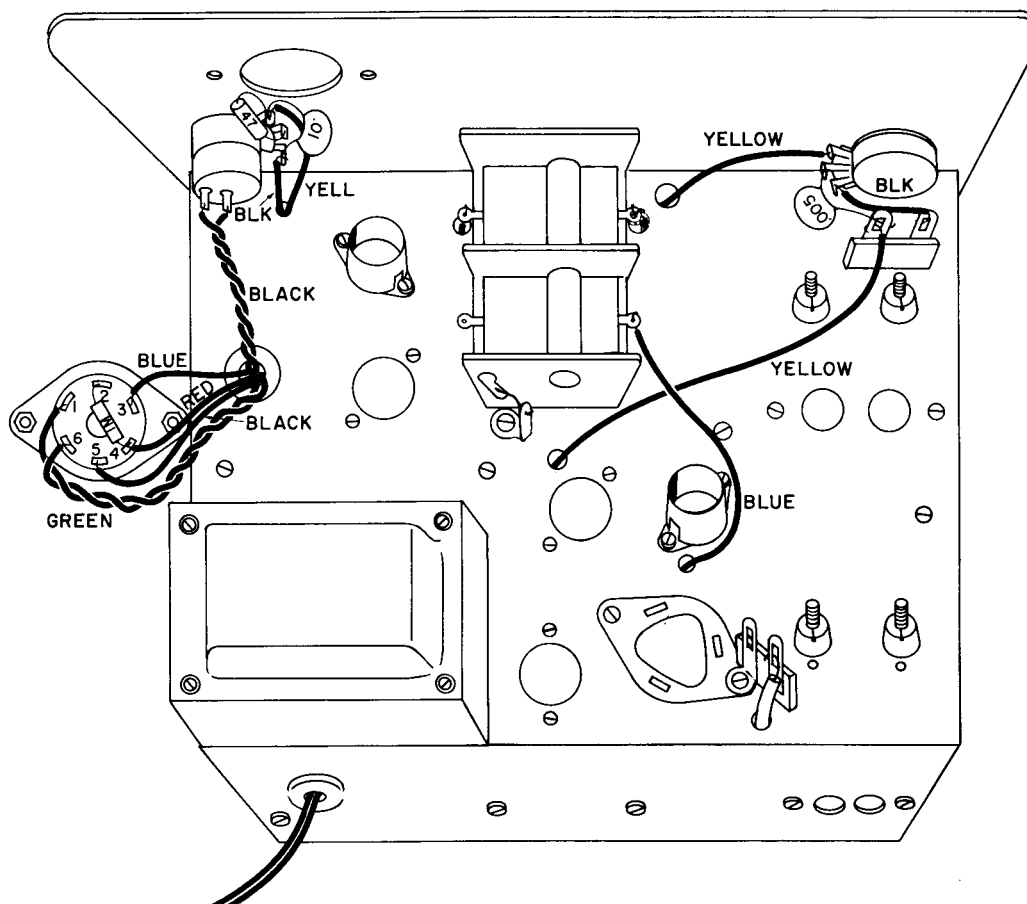

FIG. 13. Wiring above the chassis.

INSTALLING AND CONNECTING THE LOUDSPEAKER

The next thing you are to do is to install the loudspeaker in the cabinet, as shown in Fig. 14. You will need the following parts:

- One cabinet.
- One loudspeaker.
- One speaker grille.
- Four 3/8" nickel-plated 6-32 screws.
- Four No. 6 lockwashers.
- Four 6-32 nuts.
- Black hookup wire.

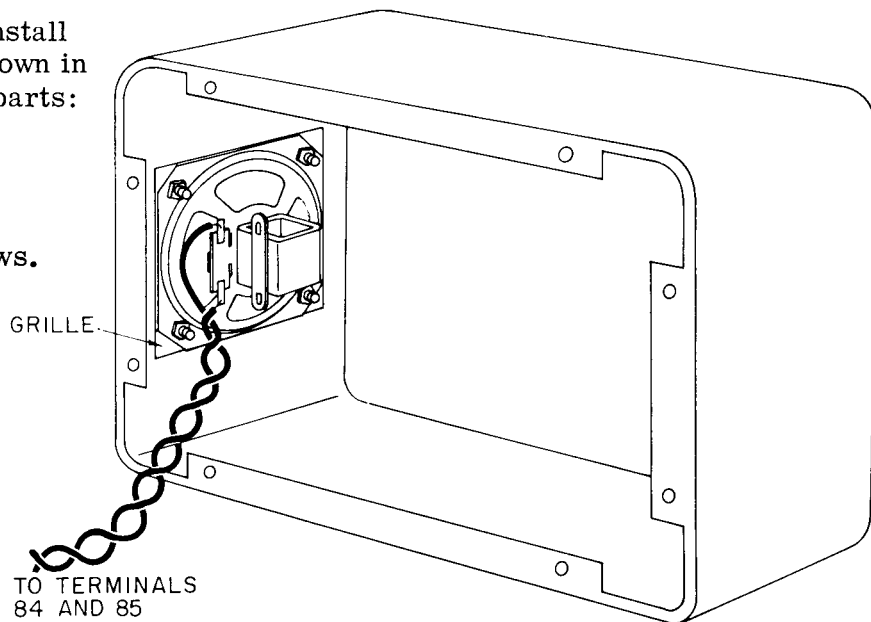

FIG. 14. Mounting the loudspeaker.

- () Twist two pieces of black hookup wire together to form a twisted pair about a foot long. Connect the two wires at one end of the pair to the speaker voice coil terminals, and solder the connections.
- () Place the speaker grille over the front of the speaker, and punch holes in the grille to match the holes in the speaker frame. Mount the speaker and grille inside the cabinet over the large hole in one end, with the speaker terminals toward the front opening of the cabinet as shown in Fig. 14. Line up the four holes in the cabinet, grille, and speaker. Insert a 3/8" 6-32 screw from the outside of the cabinet through each of the four holes. Put a No. 6 lockwasher and a 6-32 nut on each screw, and tighten them.
- () Connect the speaker leads to terminals 84 and 85 on top of the chassis and solder the connections.

Leave the signal tracer out of the cabinet until after you have aligned it.

FINAL ASSEMBLY

Next you are to mount the tubes, put on the knobs, etc. You will need the following parts:

- One 6E5 tube.
- One 6X4 tube.
- Two 6GM6 tubes.
- One 6AV6 tube.
- One 6AQ5 tube.
- Two tube shields.
- Two 4", 6-32 screws
- Two 1" spacers.
- Four 6-32 hex nuts.
- Four No. 6 lockwashers.
- Two red bar knobs.
- Two black bar knobs.
- One tuning knob.
- One plastic tuning pointer.

When you have gathered these parts, proceed with the following steps.

- () Insert a 4" 6-32 screw from the front of the panel through hole ZZ1. Attach a 1" spacer, No. 6 lockwasher and a 6-32 nut. Tighten the nut all the way down against the spacer.

- () Mount the other 4" screw in hole ZZ2 in the same way.
- () Plug the 6E5 tube into the wired 6-pin socket that you have not yet mounted. Notice that two pins, 1 and 6 are larger than the others. These are the filament pins. The corresponding socket holes are identified by a raised dot between them.
- () With the socket positioned so that pins 1 and 6 are toward the edge of the chassis as shown in Fig. 5B, put the socket mounting holes onto the 4" screws. The glass top of the 6E5 will be at panel hole ZZ.
- () Put a lockwasher and a 6-32 nut on each of the 4" screws. Tighten them about the same amount, but do not overtighten them or you will bend the socket mounting. The mounting will have enough "give" so that you can later position the tuning wedge of the eye.
- () Attach a red bar knob to the band switch so that the set screw fits against the flat side of the shaft. Tighten the set screw.
- () Turn the volume control shaft fully counter-clockwise. Attach a black bar knob. With the indicating line set on the 0 mark, tighten the set screw.
- () Attach a red bar knob to the coarse attenuator control so that the set screw fits against the flat side of the shaft. Tighten the set screw.
- () Turn the fine attenuator control shaft fully counter-clockwise. You will hear a click when the switch turns off. Attach a black bar knob. With the indicating line pointing straight down, tighten the set screw.
- () Turn the tuning shaft clockwise until the tuning capacitor plates are fully meshed. Put the plastic pointer on the shaft, with the metal bushing extending through the panel hole. Do not force the bushing against the tuning capacitor bearing or it will bind. Line up the pointer horizontally so that the red line on it is approximately centered on the broad black horizontal dial lines. Tighten both set screws, being careful not to damage the capacitor plates with the screwdriver.
- () Attach the tuning capacitor knob. Do not push it tight against the pointer bushing or it will bind. Tighten the set screws.
- () Insert the 6X4, 6AV6, 6AQ5, and two 6GM6 tubes into their sockets, referring to Fig. 5B for the proper placement.
- () Install tube shields over the two 6GM6 tubes, V_2 and V_3 . Notice that there are two raised dots on the sides of the socket. When putting on the shield, hold it as shown in Fig. 15A, so that the slight projections in its rim are directly above the raised dots. Put it down over the socket, and turn it slightly clockwise, so it will be locked in the position shown in Fig. 15B.

PUTTING THE SIGNAL TRACER INTO OPERATION

Before plugging in your signal tracer, you should make one simple check to prevent serious damage in case you have made a wiring error. Connect one lead of an ohmmeter to the chassis and the other lead to terminal 56. This is the input filter capacitor on the B+ line. The resistance should be a very high value, over 300,000 ohms. If the resistance from terminal 56 to chassis reads much less than this value, you probably have a wiring mistake or a short circuit somewhere on the B+ line. Recheck your wiring or refer to the complete schematic in the operating section of this manual. If the

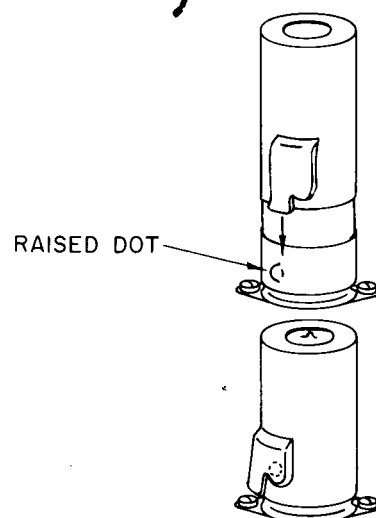

FIG. 15. How to put on a tube shield.

ohmmeter reading is above 300,000 ohms, disconnect the ohmmeter and proceed with these instructions.

Plug the line cord into a 115-volt 60-cycle ac outlet. Do not attempt to operate this instrument on dc, as it will burn out the power transformer. Turn the Fine Attenuator control clockwise. You will hear a click when the on-off switch turns "on." Observe the filaments in the vacuum tubes. They should glow within a few seconds. Observe the plates of the 6X4 rectifier tube as the instrument warms up. If the 6X4 plates glow red, or you observe arcing in the tube, turn the switch off and check for a short circuit. If the instrument warms up normally, you will see the eye (6E5) glow green as B+ comes up to the operating voltage. Do not touch the plates of the tuning capacitor, since the stationary plates are at B+ potential!

Turn the volume control to about 5. Turn the Coarse Attenuator switch to 1, and turn the Fine Attenuator control to 1. Touch the tip of the probe with your finger and you should hear a noise from the speaker.

Notice the position of the V slot in the pattern of the eye. If it is not pointed straight down, twist the 6E5 tube a slight amount until the slot is pointed straight down. This is the most convenient viewing position.

OSCILLATIONS AND INTERFERENCE

Your signal tracer is an extremely high-gain device, and several situations can cause unwanted oscillations. Particularly before you have installed the signal tracer in the cabinet, the exposed rf section of the instrument tends to pick up stray signals. A stray signal that is sufficiently amplified will overdrive one or more stages of the signal tracer, causing the stage to block. The eye will overclose, the speaker may produce whistles, and you will not be able to pick up the desired signal. Always increase the attenuation with the Coarse Attenuator switch and the Fine Attenuator control, until the eye is partially open. This will prevent overloading of the high-gain stages.

A TV set operating in the vicinity will radiate enough signals to interfere with the signal-tracer operation. The 15,750-cycle horizontal oscillator frequency of the TV set can be picked up at regular intervals across the signal tracer dial. During alignment it would be best to remove the source of interference. After the signal tracer is installed in the cabinet, the interference will ordinarily not be objectionable.

A noticeable 120-cycle hum is present when the signal tracer is set at AF, and the volume control is advanced above midrange. This con-

dition is normal, and is caused by the ripple on the well-filtered B+ voltage feeding through the 18K-ohm plate load resistor of V₂ to the volume control. Ordinarily the audio signal will override the hum, and it will not be noticeable. On AF operation you will seldom want to advance the volume control above midrange because of the high gain of the audio stages. The hum is not present at any volume control setting when the signal tracer is set for RF operation. You may have occasion to advance the volume control to a high setting when listening to a very weak RF signal.

Audio oscillations can be produced in the signal tracer when the AF gain is set too high. The oscillations are set up by the motion of the speaker diaphragm producing sound waves that feed energy back to other parts of the instrument. With the volume control set clockwise (maximum audio gain) the signal tracer will be microphonic. That is, tapping the case or any part of the signal tracer will cause a high-pitched ringing sound from the speaker. This is normal because of the high gain. Keep the volume set low enough so that the microphonics are not annoying.

When using the signal tracer as a radio receiver, the ground clip should be connected to an earth ground. The high sensitivity of the signal tracer causes it to pick up stray signals that produce interference. Providing a good ground will get rid of much of this interference.

ALIGNMENT OF THE SIGNAL TRACER USING A RADIO RECEIVER

For alignment you will need a broadcast radio receiver in good operating condition. Remove the radio from the cabinet and set it up where you can reach the under side of the chassis.

Plug the signal tracer into the power line and turn it on. Set the RF-AF switch to RF. Set the band switch to A and tune the signal tracer to the i-f of the receiver. Clip the ground lead of the signal tracer to the B- in the receiver. Hold or connect the tip of the probe to the plate of the last i-f amplifier. Tune the radio to receive a station. Change the settings of the attenuator switch and rf attenuator control as necessary to reduce the signal to the signal tracer. The correct setting is so the eye is not quite closed.

Adjust the two trimmers for band A. One band A trimmer is reached through hole P. The other band A trimmer is reached through hole FF. Both can be located on Fig. 3B. Adjust the trimmers for maximum eye closure. If the eye overcloses, open it by adjusting the coarse and fine attenuator controls.

Now tune the radio receiver to a station at the high end of the dial. Alignment will be more accurate if you know the exact frequency of the station. Turn the band switch to B, and set the dial of the signal tracer to the frequency of the received station. Connect the probe to the plate of the mixer. You should hear the radio station through the signal-tracer loudspeaker. Adjust the two trimmers for band B. One B band trimmer is reached through hole O. The other B band trimmer is reached through hole GG. Adjust trimmers for maximum closure. Keep the eye open by readjusting the coarse and fine attenuators.

Next tune the receiver to a station at the low end of the dial. Again it is desirable to know the exact frequency of the station. Set the signal tracer to the frequency of the station. If you do not get maximum closure of the eye at this point, tune the signal tracer to the correct frequency as shown on its dial, and adjust the slugs on the B band coils. These are the smaller coils. The slugs in the coils have been preset, so they should require only a small adjustment. One B-band coil is in hole M, and the other is in hole Z. Adjust the slugs for maximum eye closure. Keep the eye from overclosing by adjusting the coarse and fine attenuators.

Repeat the adjustments of the B band trimmers at the high end of the dial. Then go back in again and adjust the coil slugs at the low end of the dial. The coil and trimmer adjustments interact so that it will be necessary to repeat them several times.

This completes the alignment of the signal tracer. If a signal generator is available you can usually improve the alignment of the A band.

ALIGNMENT OF THE SIGNAL TRACER USING A SIGNAL GENERATOR

This is an alternate alignment procedure that can be used if you have an rf signal generator. Warm up the signal generator for fifteen minutes and set it to produce 200 kc. Clip the ground lead of the signal generator to the ground lead of your signal tracer. Connect the probe of the signal tracer to the rf output of the signal generator. Set the signal tracer rf-af switch to rf. Set the band switch to A. Set the tuning dial to 200 on the band A dial. Adjust the coarse and fine rf attenuators until the eye is partially closed. You can also adjust the attenuator on the signal generator as necessary to obtain a usable signal.

Locate the A band coils and trimmers from Fig. 3B. The A band coils (large coils) are located at holes N and Y. The A band trimmers are reached through holes P and FF. Adjust the

A band coils for maximum eye closure. Keep the eye partially open by adjusting the coarse and fine attenuators.

Set the signal generator at 450 kc and set the signal tracer dial at 450 kc. Adjust the A band trimmers for maximum eye closure. Adjust the fine and coarse attenuators as necessary to keep the eye partially open. Now go back and repeat the adjustment of the coils at 200 kc. The coil and trimmer adjustments interact, so it will be necessary to repeat the above adjustments several times until no change in the adjustments are required.

Now you are ready to align the B band. Set the signal generator to 500 kc. Set the signal tracer band switch at B. Set the signal tracer dial at 500 on the B band. Adjust the coarse and fine attenuators so the eye is partially closed. Locate the B band coils (small coils) and trimmers from Fig. 3B. The B band coils are located at holes M and Z. The trimmers are reached through holes O and GG. Adjust the B band coils for maximum eye closure. Adjust the rf coarse and fine attenuators as necessary to keep the eye partially opened.

Set both the signal generator and the signal tracer at 1450 kc. Adjust the B band trimmers for maximum eye closure. Adjust the coarse and fine attenuators as necessary to keep the eye partially opened. Go back and repeat the adjustment of the B band coils at 500 kc. Then come back to the trimmers at 1450 kc. Repeat the adjustments of the low and high end of the band several times.

INSTALLING THE SIGNAL TRACER IN THE CABINET

You will need the following:

Eight 1/2" nickel-plated self-tapping screws.
Two 1/4" self-tapping screws.

Unplug the signal tracer from the power outlet. Set the cabinet on its base so the speaker is to your left. Set the signal tracer chassis up-right in front of the cabinet. Thread the ac line cord inside the cabinet and out through the large line-cord hole in the back of the cabinet. Lift the chassis over the lip of the front edge of the cabinet and slide the chassis into the cabinet. Make sure the line cord is clear through the large hole in the back of the cabinet. Carefully tilt the cabinet onto its back so the panel is up. Line up the screw holes in the edge of the panel with the screw holes in the cabinet. Check to make sure that the panel is down against the cabinet. Insert 1/2" nickel-plated self-tapping metal screws in the 8 screw holes in the panel. These screws tap their own threads as they are

screwed into the holes in the cabinet. Start all 8 screws before completely tightening them. Insert the two 1/4" self-tapping screws through the two screw holes in the bottom of the cabinet. These two screws tap into matching holes in the chassis.

This completes the construction and alignment of the signal tracer. Now refer to the operating instructions so you can take advantage of the many uses of the instrument.

IN CASE OF TROUBLE

Your signal tracer will probably work properly when you complete the assembly. However it is possible that you have made a wiring mistake or an improper soldered connection, or that a part is defective.

Improperly soldered connections are the biggest cause of improper operation. If your signal tracer does not operate properly, unplug the instrument and check the soldered connections. Make sure that the solder does not cause a short circuit. Too much solder can enlarge a connection so that it makes contact with some unintended point in the circuit. Remove the excess solder by reheating the soldered joint. Hold the work so the excess solder runs down onto the iron. You can then remove the solder from the iron by shaking the iron or wiping the tip with a rag.

Examine each soldered connection. See if any wires in the connection are not soldered. If the solder on the connections looks crumbly, it may be a "cold" solder joint. A thin film of flux on one of the wires may prevent the wire from making connection in the soldered joint. To correct a cold solder joint, simply reheat the joint by holding the tinned tip of the soldering iron against the joint. When the wires and solder heat up, you can see the solder flow into the crevices between the wires and the terminals. Any flux that is present in the joint will be boiled out of the joint. Now let the joint cool. Do not move the wires of the joint until the solder has set. Be sure to check every connection in the instrument.

A wiring error may be difficult to locate by yourself. If you have misread or misinterpreted an instruction, you might make the same mistake when you go over the wiring instructions. Try to get a friend to go over the wiring steps with you.

If checking the soldered connections and rechecking the wiring steps does not correct the trouble, try to isolate the trouble to one section or one stage of the instrument. The following tests will help isolate the trouble. Check to see if the filaments in the tubes light. If the filaments light, you know that the ac line voltage

is properly applied to the power transformer, and the filament winding of the power transformer is okay. If the filaments do not light, check to see if the power transformer heats up. If it gets warm, check for a short in the filament wiring. If the filaments do not light and the transformer does not heat, check the power cord, switch, and connections.

Check to see if the eye glows green. If the eye glows, you know that the power supply is producing B plus voltage. If the eye does not glow, check the voltages given in the voltage chart in Fig. 20 on page 31 of this manual.

Check the signal path of the instrument by circuit disturbance. You can produce a circuit disturbance by touching various points in the circuit with one end of a capacitor. A .01 or a .1-mfd capacitor is suitable. Hold one lead of the capacitor in your hand and touch the other lead to a point in the signal path. Enough stray voltage will be coupled into the circuit to produce an audible hum from the speaker.

With the volume control turned up, coarse attenuator switch at 1, fine attenuator switch at 1, and the RF-AF switch set at AF, touch the tip of the probe with your finger. You should hear a popping or humming sound from the speaker. If you hear no signal, touch terminal 39. If you hear a signal now, the trouble is isolated to the probe or the wiring connecting the probe to the chassis.

If you hear no signal when you touch terminal 39, try touching terminal 89. If you hear a signal, the trouble is isolated to stage V_2 , the RF-AF switch wiring, or the wiring associated with V_2 . The sound produced by touching terminal 89 should be loud, because this is a high-impedance point in the circuit. If you hear no signal when you touch terminal 89, try touching pin 1 or pin 7 of V_7 . If this produces no signal, the trouble is in stage V_7 , the output transformer, or the speaker.

If the signal tracer works all right on AF but will not work on RF, the trouble is probably in stage V_3 , the band switch, the RF-AF switch, or the wiring to the detector section of V_5 . If the signal tracer fails to pick up weak rf signals such as radio stations, the instrument probably needs to be aligned. Perform the alignment procedure described in this manual.

Poor ground connections can cause excessive hum levels or oscillation. Check the solder connections to ground lugs. Also check to make sure the screws that hold the ground lugs to the chassis are tight. Particularly, check the screw grounding solder lug 38 to the chassis on the socket of V_2 .

If the signal tracer produces audio oscillations, check the placement of leads. Clip the ground lead to the probe tip to eliminate ex-

ternal signals. If oscillation is present, there is a feedback path in the circuit wiring. Unplug the instrument and check the lead dress of the following wires. The yellow lead from hole S to terminal 89 should lie in contact with the chassis. The yellow lead from hole E to terminal 86 on the volume control should be dressed along the front panel. The blue lead from hole AA around V_3 to terminal 81 should be about 1/4 inch above the chassis. These are the critical leads in the instrument. Other leads should be placed as shown in the pictorial diagrams.

A mistake in wiring can cause oscillations. If the signal tracer oscillates at all settings of the volume control, the trouble is probably a wiring error. If it oscillates only at high settings of the volume control, the trouble is usually caused by placement of the leads.

If the eye closes and cannot be opened by increasing the attenuation, rf oscillations are present in the signal tracer. Clip the ground lead to the probe tip and switch the attenuator to 10,000. If the eye does not open, the circuits in the signal tracer are oscillating. These oscillations may or may not produce an audible signal at the speaker. Check stages V_2 and V_3 for improper wiring. Check the lead dress on the wires coming from the bandswitch. Check the lead dress of the wires from the rf coils. Make sure that the component leads for stages V_2 and V_3 are short and properly positioned.

The parts supplied with this kit are of high quality. These parts have been carefully selected to perform their required function. Oc-

asionally improper operation of an instrument can be traced to a defective tube or other circuit component. If you find a defective component, write us and return the defective part for a replacement. Do not dismantle the defective component, as this will void the guarantee. This guarantee does not cover free replacement of parts that have been damaged through carelessness on the part of the kit builder.

If you have a defect in your signal tracer that you cannot locate, write us describing in detail, the trouble you are experiencing. Make a voltage chart like the one shown in Fig. 20, and record the voltage readings that you get on your signal tracer. We will try to give you the information needed to get your signal tracer working.

If you cannot get your signal tracer working yourself, you can return it for repair. If it is necessary to do this, we will make a service charge of \$7.50 plus the cost of any parts that have been damaged due to wiring errors. If you should send your signal tracer to us for repair, proceed as follows:

1. Write to us that it is on the way, and explain the nature of your difficulty.
2. Enclose your remittance for the \$7.50 service charge with your letter. Use a check or money order; do not send cash.
3. Pack the signal tracer in a sturdy carton. Protect the instrument by filling the extra space with crushed newspapers.
4. Send it to us by prepaid express or insured parcel post. We will return your instrument express collect.

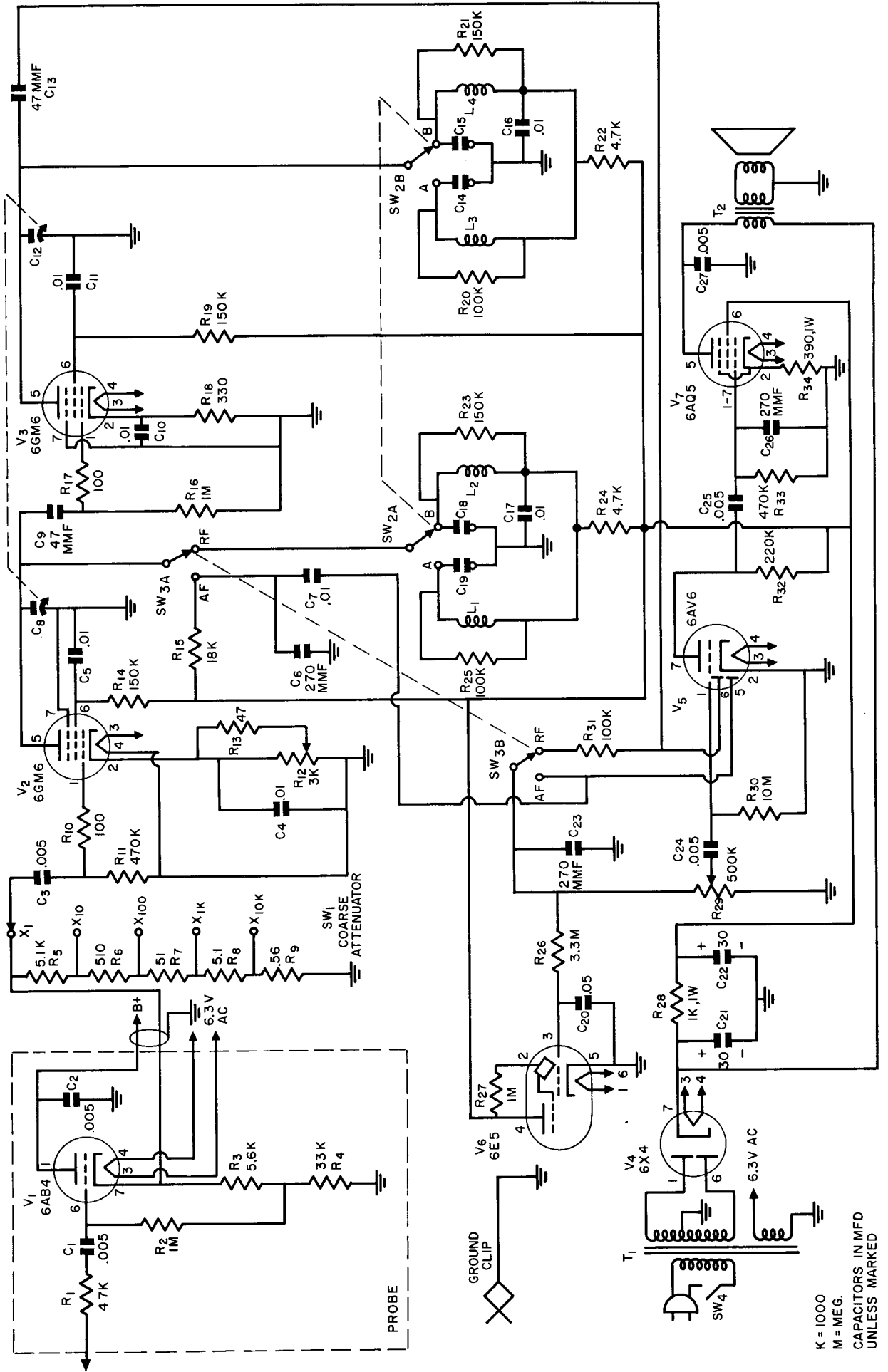

FIG. 16. Schematic diagram of the Model 230 signal tracer.

K = 1000
M = MEG.
CAPACITORS IN MFD
UNLESS MARKED

INSTRUCTIONS FOR OPERATING THE CONAR MODEL 230 TUNED SIGNAL TRACER

WHAT IS SIGNAL TRACING?

Signal tracing means sampling or examining the signal voltage at various points in a receiver as it passes from the antenna through the receiver to the loudspeaker. In using a signal tracer, when you pass from a point of normal signal to the point at which your signal tracer verifies or confirms a complaint, you have just passed into or through the defective stage.

The signal tracer enables you to examine the frequency, the quantity, and the quality of the signal. If the set is dead, you can determine where the signal stops. If the complaint is weak reception, you can find which stage is causing a loss rather than a gain in signal strength. If distortion, noise, hum, or oscillation is the symptom, the signal tracer will quickly narrow your search to the defective stage, and in many cases to the defective part itself.

FUNCTION OF THE CONTROLS

There are six controls on the front panel of the Model 230. They are described below.

Volume Control. Controls the loudness of the sound from the signal-tracer speaker. Its setting has no effect on the other controls. Regardless of the setting of the other controls, the volume control is adjusted to produce the sound level you desire.

RF-AF Switch. Decides the basic function of the signal tracer. It is also called the function switch. With this switch in the RF position, the signal tracer will pick up rf signals, and with it in the AF position, only audio signals can be picked up.

Band Selector Switch. Governs the rf coverage of the signal tracer. In position A, the tracer tunes from 170 to 500 kc, and in position B, the range is from 500 to 1500 kc.

Tuning Knob. Tunes the tracer over the A and B bands. The frequency of either band is indicated by the double pointer. The knob drives a planetary gear, which in turn drives the tuning capacitor gang and pointer. Approximately three complete turns of the knob are required to cover the band.

Coarse Attenuator. Enables you to vary the strength of the signal before applying it to the amplifier system of the signal tracer. This switch works in steps from 1 (zero attenuation) to 10,000. Each step gives a signal one tenth as strong as the preceding one, so that the last position delivers only one ten-thousandth of the

original signal to the amplifier.

Fine Attenuator. Gives continuous control of the amplifier gain with full gain at a setting of 1, and one-tenth full-gain at a setting of 10.

In addition to these controls, we have the tuning eye, the ground lead with clip, and the probe.

The Tuning Eye. A level indicator used in making gain measurements. In using the signal tracer, the attenuators are set so the eye does not overclose.

The Ground Lead and Probe. These are the input leads of the signal tracer. The ground lead is clipped to the low-potential side of the receiver. In an ac set, this is the chassis. In a three-way portable or an ac-dc receiver, the low potential side is the lug on the on-off switch that connects to the receiver circuits. Any point in the receiver connected to this lug can be used as the ground lead connection point. For example, the negative leads of the electrolytic filter capacitors, or the low-potential side of the volume control. If it is difficult to get a satisfactory clip connection, just solder a piece of hook-up wire to the point in question and clip the ground lead to the end of this wire.

In transistor receivers, any point shown in the schematic as ground may be used to attach the ground lead. In general you can clip to the frame of the tuning capacitor or to the low potential side of the volume control.

The sharp point of the probe is touched to the receiver circuit where you wish to sample the signal. The sharp probe tip will enable you to pierce insulation and to cut through the lacquer spray used on printed circuit boards. When you wish to connect the probe to some point in the receiver more permanently, you can use an alligator clip terminating in a pinjack connector. The probe tip will slip into the pin jack. If the probe cannot be supported in position by the pinjack, solder a short length of wire to the circuit and attach the alligator clip to the end of this wire. Such an alligator clip can be obtained from any wholesale house and is not furnished as a part of the signal tracer.

DESCRIPTION OF THE SIGNAL TRACER

You do not need to understand the internal operation of your instrument, but if you are interested, you can study the schematic diagram, Fig. 16, which is on one of the sheets stapled into the center of this manual.

When the Function switch is thrown to RF the instrument is a two-band TRF receiver tunable from 170 kc to 1500 kc. The tuning

eye monitors the rf signal level at the detector. The signal input to tube V_2 is controlled by the coarse attenuator (SW_1), and the gain of V_2 is controlled by varying the bias of V_2 by means of R_{12} . With the function switch in the AF position, V_2 is changed to an audio amplifier and its output is monitored by the tuning eye. Thus, the setting of the volume control has no effect on the operation of the eye.

The cathode follower in the probe and the coarse and fine attenuators work on both rf and af signals.

TEST PROCEDURE FOR TUBE RECEIVERS

The Conar Signal Tracer is a powerful tool for the solution of service problems. For best results, a systematic method of use should be adopted.

Let us see how to trace signals through a tube receiver, using the Model 230 Signal Tracer. Later on you will see that the procedure on a transistor set is almost exactly the same. Fig. 17 shows a complete schematic diagram of the set. The various signal tracing steps are as follows.

1. Plug the receiver and Model 230 into an ac power line and allow both to warm up.
2. Clip the "ground" lead of the Model 230 to a B- point on the receiver.
3. Set both attenuators to 1, and set the volume control to 5.
4. Throw the RF-AF switch to RF.
5. Tune in a strong station between 500-kc and 1450-kc on the receiver.
6. Set the band selector switch of the signal tracer to Band "B", which covers the frequen-

cies mentioned in Step 5.

7. Touch the probe to the antenna lead on the receiver (free lead at C_3) in Fig. 17.

8. Tune the Model 230 until you hear the same program that is coming from the receiver's loudspeaker. (Make any attenuator adjustments necessary to prevent overloading.)

9. Move the probe to the signal grid of the mixer tube. If necessary, retune the receiver for maximum closure of the signal tracer tuning eye. If the tuning eye overlaps, increase the setting of the fine or coarse attenuator as necessary, so that the tuning eye just closes.

10. Remove the probe from the mixer grid and retune the receiver if you changed its dial setting in Step 9.

11. Turn the signal tracer band selector switch to Band A, which covers the intermediate frequency of this receiver. Tune the Model 230 to 455-kc (halfway between 450 and the next scale mark counterclockwise.)

12. Touch the probe to the plate terminal of the mixer tube. The i-f signal of the receiver should now be audible in the speaker of the Model 230. If not, tune the Model 230 on both sides of 455-kc, as the i-f of the receiver may be slightly misaligned or the receiver slightly mistuned. If necessary, adjust the attenuators until the eye just closes, and turn the volume control so that the program is audible in the Model 230 loudspeaker.

13. Move the probe to the control grid of the first i-f amplifier tube. The eye will open up, showing a decrease in amplitude of the receiver's i-f signal. This is correct as there is normally a loss in a double-tuned i-f transformer.

14. Shift the probe to the plate socket termi-

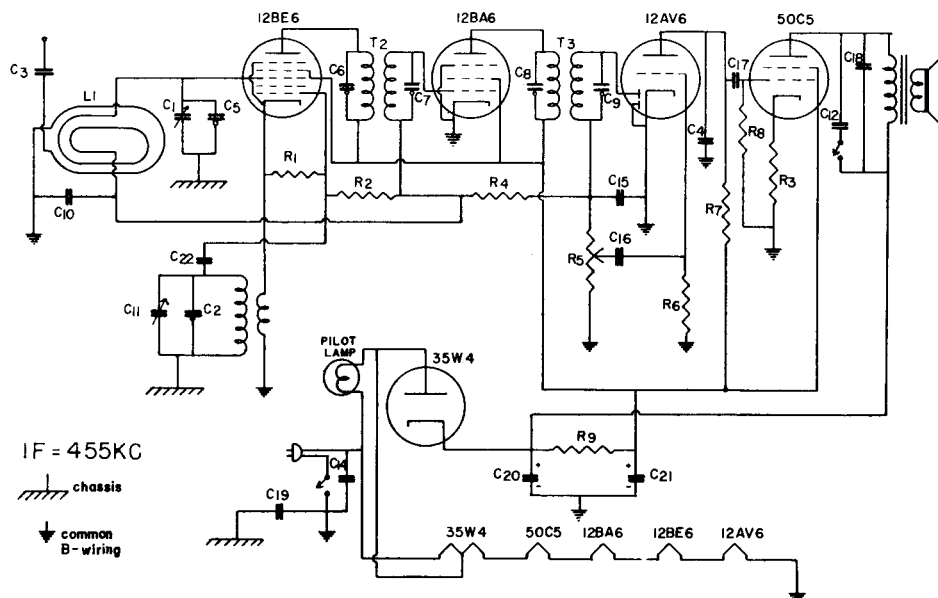

FIG. 17. Schematic diagram of a modern radio receiver.

nal of the i-f amplifier tube. The tuning eye should overlap because of the gain in the i-f stage. It should be necessary to turn the Coarse Attenuator control from one to 10, 100, 1000, or even 10,000, before you can adjust the closure of the tuning eye with the fine attenuator. (The gain of the i-f tube should also be apparent by increased audible output from the Model 230 loudspeaker).

15. Touch the probe to the diode detector plate of the 12AV6 tube. Some decrease in signal strength will be noted.

16. Next shift the probe to the ungrounded side of volume control R_5 . To pick up the i-f signal, you must set the attenuator for maximum sensitivity, as only a small amount of the i-f signal should exist at this point. Most of the i-f signal has been filtered out by C_{15} leaving the audio signal across R_5 . This completes the signal tracing in the rf and i-f sections of the receiver.

17. Slide the RF-AF switch to the AF position, and touch the probe to the "hot" (ungrounded) side of volume control R_5 , and listen to the audio signal at this point. The attenuators and volume control may be used to decrease the output of the Model 230.

18. Move the probe to the plate of the first af amplifier tube (plate socket terminal of the 12AV6). A large increase in volume should result. This may be decreased to a reasonable level by turning the attenuators to a higher number or by turning down the volume of the signal tracer or of the receiver.

19. Next touch the probe to the control grid of the 50C5 output tube. The signal level from the Model 230 loudspeaker should be about the same as in the preceding step.

20. Move the probe to the plate socket terminal of the output tube. An increase in signal level should be noted.

21. Disconnect the "ground" lead clip of the Model 230 from the receiver and connect it to one of the receiver loudspeaker voice coil leads. Touch the probe to the other voice coil lead. A large drop in signal level is to be expected because of the step-down action of the output transformer. It will probably be necessary to change both attenuator settings.

We have traced the signal through each stage of the receiver from the antenna to the loudspeaker voice coil. These are the points where you will make tests on an improperly operating set.

To get experience it will be worthwhile for you to go through this procedure on one or more receivers in good operating condition. This will enable you to get the feel of your instrument. Whenever possible, obtain a schematic diagram of the receiver you are testing. Now, let us see

how tests would be made on a receiver using transistors instead of tubes.

TEST PROCEDURE FOR TRANSISTOR RECEIVERS

Fig. 18 shows a typical transistor receiver. It uses a loopstick antenna L_1 , a mixer-oscillator, two i-f stages, a germanium crystal in the second detector-AVC stage, a driver stage, and two transistors in the Class AB push-pull output stage.

There are some slight differences in signal tracing techniques used on tube and transistor receivers. In a transistor set, a strong signal from the local oscillator is present in the loopstick.

To avoid swamping the signal tracer with the oscillator signal, the receiver is turned off when checking the input of the mixer base (point 3). A short-cut check of the front end with the receiver turned on is to pick up the rf signal at point 4. If the rf signal is picked up at this point you know that the antenna circuit is working, that rf signals are being applied to the mixer base, and that the rf signal current flows in the collector circuit. If you can also pick up the i-f signal at point 4, the local oscillator is working.

If it is necessary to determine if the loopstick is working and signals are reaching the mixer base, proceed as described in the following discussion of each test point. The test points for signal tracing are marked 1 through 17. For all tests the ground lead of the signal tracer is connected to the receiver chassis.

Points 1, 2, and 3. Set the signal tracer to band B and tune in a station somewhere near the middle of the broadcast band. Turn the receiver off, clip the ground lead of the signal tracer to the receiver chassis and touch the probe to point 1. This will probably reduce the strength of the signal in the tracer although you may still hear something if the attenuators are turned up for greater sensitivity. Now tune the receiver over the broadcast band. At some point the signal level of the tracer should increase. If it does it shows that the primary of antenna coil L_1 and the tuning capacitor are in good condition. Move the probe to point 2 and repeat the procedure. You should be able to pick the station up again after retuning the receiver, although with reduced strength because of the step-down action of the loop antenna and its secondary. Now without retuning the receiver, you should again be able to pick up the signal at point 3, which shows that capacitor C_1 is not open.

Point 4. Turn the receiver on, set the band switch of the signal tracer to A and tune the

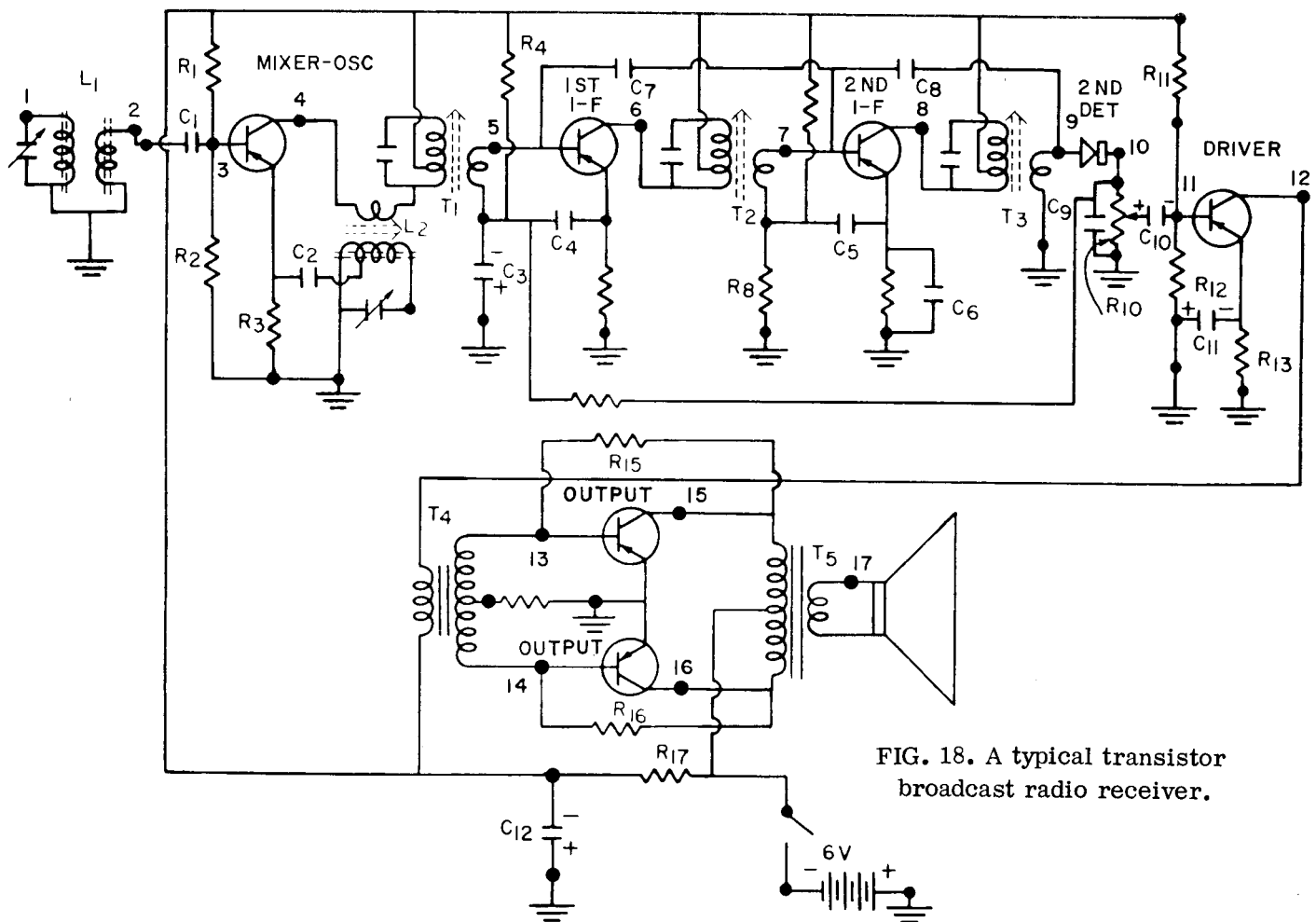

FIG. 18. A typical transistor broadcast radio receiver.

signal tracer to approximately 455-kc. Touch the probe to point 4 and retune the receiver slightly if necessary to pick up a signal. You might also find it necessary to slightly retune the signal tracer, as the i-f of the receiver may not be exactly 455-kc. In some cases an i-f of 262-kc is used but this will be indicated on the receiver schematic.

Point 5. With the signal tracer probe touched to point 5 you would still pick up the signal but with greatly reduced volume due to the step-down action of the i-f transformer. Remember that the i-f transformer secondary delivers power to the input of the first i-f transistor - not maximum voltage.

Point 6. At point 6 a very large increase in signal strength will be noted and it will be necessary to set the attenuators to higher numbers.

Point 7. Again a decrease in signal will be noted at point 7. The signal at point 7 will be greater than at point 5.

Point 8. A very great increase in signal strength will be noted at point 8.

Point 9. At point 9, a decrease in signal voltage strength will be noted but the signal will be greater than at point 7. If signals are picked up at this point, you know that everything be-

tween points 9 and 1 is working properly.

Point 10. This is an audio point, and the function switch of the signal tracer should be pushed to the AF position. Touch the probe to point 10 and listen to the audio signal. If no audio signal is present at point 10, but you were able to obtain the i-f signal at point 9, the diode detector is probably defective.

Point 11. Here you should be able to pick up practically as much signal as at point 10 if volume control R_{10} of the receiver is advanced to maximum.

Point 12. An increase in signal voltage over that obtained at point 11, will be noted.

Points 13 and 14. Low level signal voltages are present at these points because of the step-down action of T_4 . The signals will be audible but will be weaker than at point 12.

Points 15 and 16. The signals at these points have a high level and it will be necessary for you to reduce the attenuator settings.

Point 17. Here a signal is available, but the level is far less than at points 15 and 16 due to the step-down action of output transformer T_5 .

You have now traced through the entire circuit of the transistor receiver. Any interruption of the signal or a change in the tone quality would indicate a defective stage or part.

Although the presence of an i-f signal at point 4 shows that the local oscillator is working, you can pick up the oscillator signal by holding the probe near the oscillator coil with the switch set to band B. The local oscillator frequency will be the frequency of the incoming signal plus the value of the i-f. For example, if a receiver with a 455-kc i-f is tuned to a station at 780 kc, the local oscillator frequency should be 780 plus 455, or 1235 kc. You can pick up this local oscillator signal by tuning the signal tracer to 1235 kc.

Short Cuts in Checking Transistor Receivers. After you become familiar with the use of your tester on transistor sets, you can save time by applying some of the short-cut methods listed below.

1. The first quick check should be the i-f stages because this immediately enables you to determine whether the trouble is in the rf-if section or the audio section. The signal tracer is extremely sensitive, and it is not always necessary to get at the bottom of the receiver chassis to locate test points. Very often you need only hold the tracer probe near the i-f stages to pick up an i-f signal. A better pick-up can be obtained by touching the probe to the case of a transistor. If the transistor case is not grounded, considerable signal will be present. Also, where powdered iron cores are used in the i-f transformers, you can touch the probe tip to the core and pick up a signal at this point. As you progress from the output of the mixer towards the second detector, each succeeding stage will deliver a stronger signal.

2. In many instances signals may be picked up in the audio section with the function switch set to AF by touching the probe tip to the cases of the audio transistors. Where this is not possible, it will be necessary to remove the chassis from the cabinet so you can get at the various electrode connections of the audio transistors.

SERVICING WEAK RECEIVERS

When it comes to localizing trouble in a weak receiver, there is nothing that equals the signal tracer. With it you can actually measure the signal voltage gain per stage.

For simplicity, instead of determining the exact amount of signal in volts, you get a comparison by determining how much greater the signal is at one point than it is at another point. This comparison, or ratio, gives the gain of the section or stage, and tells you at once whether or not things are normal within that portion of the radio.

Of course, you must know what gain to expect in each portion of the radio. Many manu-

facturers include stage-by-stage gain measurements in the information on their tube-type sets. Some do not, and for these sets, you will have to rely on average gain values. As a matter of fact, average gain values are generally more reliable, because set manufacturers may take their measurements with a particular make of instrument, and an instrument of another make may not give exactly the same results. This is particularly true where a change in frequency is involved, as it is when measuring converter gain from the input of the mixer of a superheterodyne to its output. The reason for inaccuracy at this point is that the sensitivity of most signal tracers is not constant over a given band or between bands. However, we have worked out a very simple system of obtaining tube converter gain with the Model 230 as you will learn now.

In a transistor receiver, no attempt is made to amplify signal voltage. Therefore measurement of relative signal voltages is not a true indication of stage gain. In many cases the signal voltage at the base of a transistor, near the input of the set, may be too small to close the tuning eye. However, there is some relationship between the signal voltage and gain at the output of i-f stages in a transistor receiver.

In Fig. 18 for example, it is possible to compare the signal voltages at points 4, 6, and 8. This comparison will give some idea of the stage gain. Comparison of the signal voltages at points 1 and 4 will give some idea of converter gain, but the signal voltage at point 3 would not be great enough to close the eye of the tracer. However, the signal can be followed and its condition examined, and this is of extreme importance. Audio gain measurements are also impractical to make in a transistor receiver, but again the presence or absence of signal can be determined, as well as the quality of any signals present.

Gain Measurements. In making stage gain measurements, it is only necessary to determine how many times stronger or weaker the signal is at the input of a stage than at its output. With the Model 230, you do not measure the signal level in volts, but instead you read the attenuator setting required to close the tuning eye for the particular signal in question. Suppose that to close the eye at the grid of a tube, the fine attenuator is set halfway between 3 and 4. This is read 3.5. Also, you find that the coarse attenuator is set to 10. You would multiply the two settings: 3.5×10 equals 35, which is the relative signal strength at the grid of the tube. Now, move the probe to the plate of the tube. The signal will be much stronger here, and you may find it necessary to set the

Input Frequency	I-F	Multiply by
1000 kc	175 kc	.5
1000 kc	256 kc	1.0
1000 kc	370 kc	2.0
1000 kc	456 kc or 455 kc	2.9
1000 kc	470 kc	2.9

TABLE 1. Correction factors for i-f's in AM receivers.

coarse attenuator to 100, and the fine to 7. Multiplying the coarse and fine settings, we obtain 100×7 , or 700 as the relative signal strength at the plate of the tube. THE RELATIVE PLATE SIGNAL STRENGTH DIVIDED BY THE RELATIVE GRID SIGNAL STRENGTH IS THE GAIN OF THE STAGE. Thus, the gain of this stage is 20 ($700 \div 35$). If the relative signal strength at the plate were 70 rather than 700, the stage gain would be $70 \div 35$, or 2. But suppose the relative signal strength at the plate were 7. At once you would know that there was less signal at the plate than at the grid, and that a LOSS rather than a gain has occurred. The actual "gain" would be found by dividing the plate reading by the grid reading. In this case $7 \div 35$ equals .2, and we say that the gain is .2.

Since gain measurements on a superheterodyne mixer stage are taken at two frequencies, the signal frequency and the i-f, division of the

output reading by the input reading will not always give the true gain. However, if you multiply the gain value you obtain by the right correction factor, the results will be quite accurate. The correction factor will vary with the difference between the signal frequency at the mixer grid, and the intermediate frequency at the mixer plate, as this factor depends on the difference in signal tracer sensitivity at the two frequencies involved. Table 1 gives the correction factors for the i-f's found in standard AM receivers. Note that in each case the input frequency must be 1000 kc, which can be obtained from a station or a signal generator. As a matter of fact, any station between 900 kc and 1100 kc can be used and the results will still be acceptable.

Table 2 lists what are considered to be average gain values in tube receivers, and Table 3 gives the manufacturer's gain figures for the set shown in Fig. 19. As you can see by comparing the two, some of the values in Table 3 are within the average, but others are somewhat outside. Therefore, you can't rely on average values absolutely -- you will have to supplement them with what you learn from experience with specific receivers. Even when you get a reading this is within the average limits, you will have to be careful. It may be below normal for that particular radio. That is, if you get a reading near the minimum value of Table 2, you won't always know whether this is natural for the receiver, or whether the gain for this

STAGE	MEASUREMENT	GAIN	
		MIN	MAX
RF	Antenna to 1st grid	2	10
	Antenna to 1st grid, auto sets	10	50
	RF amplifier, superheterodynes	10	40
	RF amplifier, trf, broadcast	40	100
MIXER	Converter grid to 1st i-f grid (single i-f stage)	30	60
	Converter grid to 1st i-f grid (two-stage i-f)	5	30
I-F AMP.	I-F stage (single stage)	40	180
	I-F stage (two-stage i-f, per stage)	5	30
DET.	Biased detector, 57, 6J7, 6C6, etc. (depends on % modulation)	5	40
	Grid-leak detector, square law	5	50
	Diode detector (a loss - depends on % modulation)	.2	.5
AUDIO AMP.	Triode (low-gain)	5	14
	Triode (high-gain)	22	50
	Pentode	50	150
POWER OUTPUT	Triode	2	3
	Pentode and beam	6	20

TABLE 2. Average gain data for tubes.

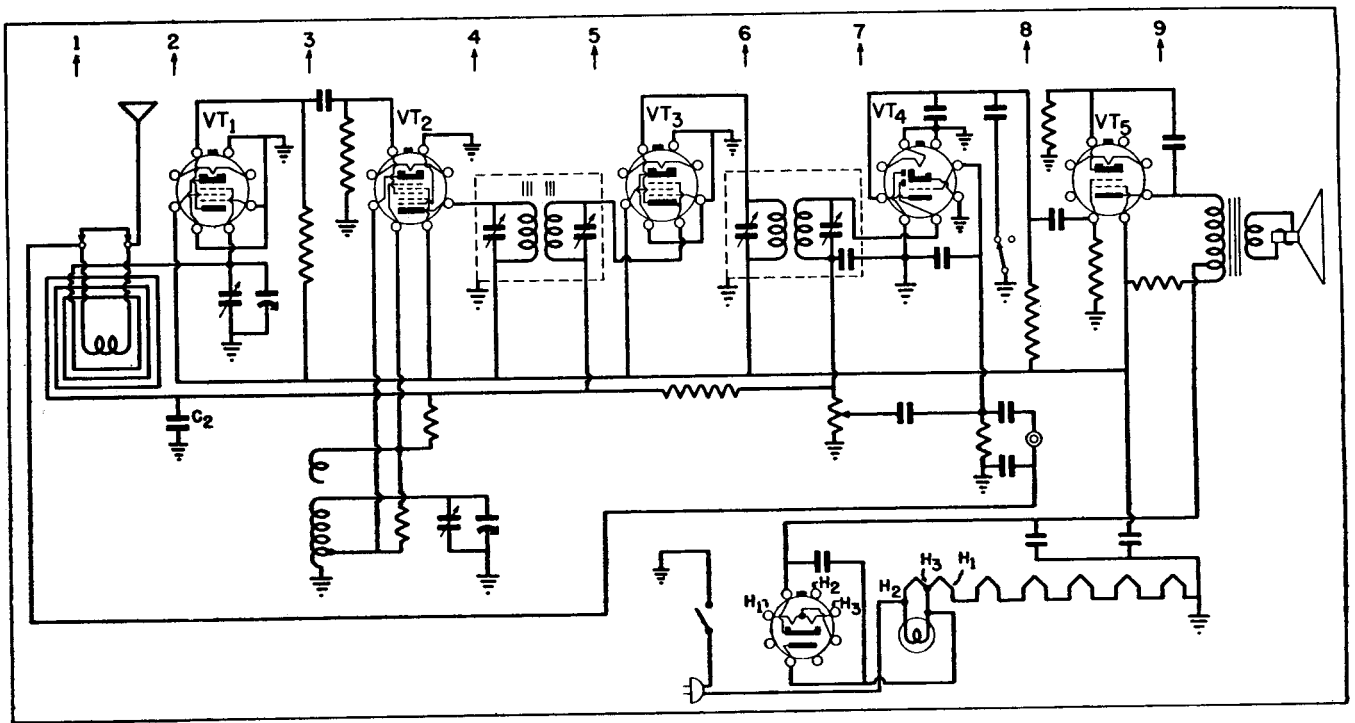

FIG. 19. Schematic diagram of a radio receiver showing where to make gain measurements.

particular stage should be near the maximum and is actually far below normal. Be guided in cases like this by the gain values you get in the rest of the receiver. If the manufacturer has designed one section to have fairly low gain, then another section must make up for this by having a higher gain.

Table 4 gives average signal voltage gain values in the converter and i-f sections of transistor receivers. The signal at the antenna point 1 in Fig. 18 is obtained with the receiver turned off, while the i-f signal at the mixer output is obtained with the receiver turned on and retuned to the same station picked up at point 1.

Notice that when two i-f stages are used, the gain of the second stage is very high compared

to the first stage. In reflex receivers using a single i-f stage, the i-f stage gain may vary from a low of 15 to a high of 50.

Examples of Gain Measurements. Now, let's see how to make gain measurements on the set shown in Fig. 19. To use the signal tracer, you must have a signal, either from a local broadcast station or from a signal generator, to feed into the set. The signal generator is preferable, particularly when you expect to make gain measurements in the audio section of the receiver, because there, a steady audio signal of unvarying amplitude is necessary. Let's suppose you are going to use a signal generator.

The gain of the rf and i-f stages in modern receivers depends on the avc voltage. Hence, most manufacturers recommend that the avc voltage be killed while making gain measurements -- in the case of Fig. 19, this can be done by shorting the avc filter capacitor C_2 . Shorting the avc in this way permits the set to operate with a maximum and fixed sensitivity. Notice in Table 3 that the rf stage gain varies from 1 to 7, depending on whether or not the avc is working.

Table 3 shows that the signal strength is increased 2.5 times (the gain is 2.5) between the input and the rf amplifier grid of the receiver in Fig. 19. This measurement, as the table also shows, is to be made with a 1000-kc signal input. Therefore, tune the receiver, the signal generator, and the signal tracer to 1000 kc. Remove the antenna-ground shorting bar, and connect the signal generator to the antenna

POINTS OF MEASUREMENT	TRACER TUNED TO	APPROX. GAIN
1 and 2	1000 kc	2.5
2 and 3	1000 kc	1* or 7**
3 and 4	455 kc	70
4 and 5	455 kc	0.7
5 and 6	455 kc	60* or 125**
6 and 7	455 kc	0.7
7 and 8	400 cps	30
8 and 9	400 cps	15

*With avc voltage applied.

**With avc voltage shorted out.

TABLE 3. Gain data for the set shown in Fig. 19.

STAGE	MEASUREMENT	GAIN	
		MIN.	MAX.
MIXER	Antenna to mixer collector	1.3	12
I-F (2 i-f stages)	Base of 1st i-f amplifier to base of 2nd i-f amplifier	2	12
	Base of 2nd i-f amplifier to 2nd detector	100	125
I-F (1 i-f stage)	Base of i-f amplifier to 2nd detector	15	50

TABLE 4. Average gain data for transistors.

and ground posts of the receiver. Attach the ground lead of the signal tracer to the B- point of the receiver. Set the slide switch to RF, the band selector switch to B, and touch the probe to the antenna post. Adjust the two calibrated attenuators of the signal tracer until the indicator eye just closes. If necessary, increase the output of the signal generator.

Multiply together the fine and coarse attenuator settings. The result represents the relative signal strength needed at this point to close the indicator eye.

Next, move the probe to the control grid of VT_1 . Adjust the attenuators until the indicator eye just closes, and again multiply the coarse and fine settings together to get the relative signal strength at this point. The ratio between this attenuator value and the previous one shows the gain or loss in signal strength between the antenna and the control grid of VT_1 . (Thus, if the first value is 3, and the second is 8, the gain is $8 \div 3$, or approximately 2.7.) If a gain of about 2.5 is found, you know that the input section of this receiver is functioning properly.

Next, move the probe of the signal tracer to the plate socket terminal of VT_1 . Adjust the attenuators until the indicator eye closes. The ratio between this new attenuator value and that at the grid of VT_1 should be about 7 to 1 when the avc is not working.

The signal strength at the plate of VT_1 and at the grid of VT_2 is approximately equal, so no measurement need be taken at the grid of VT_2 .

Next, reset the band selector switch at "A" and tune the signal tracer to 455 kc, the frequency of the i-f amplifier. Touch the probe to the plate of VT_2 . Adjust the attenuators until the indicator eye of the signal tracer closes. The ratio of the attenuator settings at the grid and at the plate of VT_2 should be about 28 to 1. Multiplying by the correction factor of 2.5, for an i-f of 455 kc, will give the true gain as 28×2.5 , or 70.

Next, touch the probe to the control grid of

VT_3 , and adjust the attenuators for closing of the indicator eye. The "gain" of this i-f transformer should be about .7 (actually, this represents a loss, which is to be expected in a double-tuned i-f transformer).

Next, move the probe to the plate of VT_3 , and adjust the attenuators for closing of the indicator eye. The gain of VT_3 should be about 125 if the avc is not working (about 60 if it is). In this stage, the attenuator setting at the grid may be 20, and the attenuator setting at the plate may be 2500. The gain is therefore $2500 \div 20$, or 125. (Notice that the ATTENUATORS are calibrated to cover a range of from 1 to 10,000.)

Finally, touch the probe to the ungrounded diode plate of VT_4 . This should show a "gain" of .7- the loss occurring in the second i-f transformer. This completes the gain measurements in the rf-if section of this receiver. AF gain measurements are taken in the same way, with the slide switch set at AF.

SERVICING RECEIVERS THAT DISTORT

The receiver in which distortion is to be localized should be tuned to a station so that its loudspeaker will reproduce that distortion. With the receiver volume set at a low level, connect the Model 230 ground lead to B- on the receiver. Set the slide switch to AF, and touch the probe to the ungrounded side of the receiver voice coil. (If one side of the voice coil is not grounded, the Model 230 ground lead should be clipped directly to one side of the voice coil, and the probe to the other side.) Turn up the signal tracer gain, so that the audio output from the signal tracer exceeds the output from the receiver. Listen for the distortion. If it is absent in the output from the signal tracer, you know at once that the receiver loudspeaker is at fault and appropriate steps should be taken to correct the speaker trouble.

If the distortion is present across the speak-

er voice coil, it is still possible that the loudspeaker is defective. You should proceed to mute the speaker by disconnecting one lead of its voice coil. Substitute a dummy load of a 10-ohm, 5-to-10 watt resistor in place of the speaker voice coil. Using the signal tracer, check the audio voltage appearing across the dummy load resistor for distortion. If reception is now normal, the loudspeaker is definitely at fault. (Note: In making this check, the signal tracer ground lead should go to the grounded side of the speaker voice coil if one side of the voice coil is grounded. Otherwise, connect the probe to either side of the dummy load and the ground lead to the other.)

If the distortion continues, reconnect the Model 230 ground lead to the receiver B-lead, and touch the probe to the ungrounded side of the diode load resistor, where the detected audio signals are first developed. If the distortion is not present at the diode load, proceed to trace the audio signal toward the loudspeaker, using the audio section of the signal tracer, just as was previously described. The first point at which the distortion is present indicates that you have just passed through the defective stage. You should then concentrate on that stage, checking the operating voltages with a dc voltmeter and being on the lookout for defective parts, tubes, or transistors.

Perhaps the most common cause for distortion is a defective transistor, a leaky coupling capacitor, or a gassy tube. Many servicemen who regularly use a signal tracer will first, in the case of distortion, check for leaky coupling capacitors and gassy tubes with a dc voltmeter before resorting to the signal tracing procedure. DC voltage measurement will often show up a leaky transistor or incorrect base-emitter bias.

If distortion is present across the diode load resistor, set the slide switch to RF and prepare the signal tracer to pick up the i-f signals, by changing the band selector switch to Band "A".

Touch the RF probe to the input of the diode detector, and tune in the i-f signal on the signal tracer. If there is no distortion at the input of the detector, but the af output of the detector is distorted, a new 2nd detector should be tried. Also, the resistance of the diode load resistor should be checked with an ohmmeter. Too high a diode load resistance can cause distortion.

If the distortion is present across the input to the diode detector, touch the RF probe to the input of the i-f amplifier driving the 2nd detector. If distortion does not exist here, but is present at the output, try a new tube, or if a transistor is used, check its operating volt-

ages before trying a replacement transistor. Also, use a high-resistance dc voltmeter to check the avc voltage applied to this stage. Lack of avc voltage can cause the stage to deliver a distorted signal to the 2nd detector. Check the avc circuit for continuity and the avc filter capacitors for leakage or for a short. Also be on the lookout for oscillation in the rf or i-f sections of the receiver. Instructions for using the Model 230 to localize oscillation are given later.

SERVICING RECEIVERS FOR EXCESSIVE HUM

In most sets, excessive hum is caused by defective electrolytic capacitors or cathode-to-heater leakage in tubes. It is advisable to check these parts first before trying to localize the point at which hum enters the receiver circuit. The tubes may be checked for leakage in a reliable tube tester; to check the capacitors you can shunt them with good capacitors, or check them with an RC tester.

The signal tracer can be used to check for excessive hum voltage across the filter capacitors. To do this, prepare the Model 230 for AF listening tests by throwing the slide switch to AF. Clip the ground lead to the negative lead of the capacitor under test. (Do not unsolder the capacitor leads.) Touch the probe to the positive capacitor lead. Set the attenuators so that the amount of hum can be readily heard. The hum should be very loud across the input filter capacitor. However, hum should be at a low level across the output filter capacitor.

After you have made this test on a few receivers in first-class condition, you will know how to interpret the results of this test.

When the tubes and filter capacitors are not at fault, trace the hum to its point of entry into the receiver and then concentrate on that circuit.

If hum modulation is the complaint, tune the receiver to a powerful local station, or use the unmodulated signal from a signal generator. Trace the signal from the antenna towards the second detector, until you find the stage in which the hum modulation first starts. The regular rf signal-tracing procedure previously explained, should be used.

SERVICING RECEIVERS THAT SQUEAL

When you are servicing a receiver that squeals or motorboats, make the necessary preliminary inspection for surface defects, being on the lookout for shielding out of place, poor grounding of shields, dirty wiping contacts on the tuning capacitor rotor shaft, etc.

Disconnect the receiver antenna, or be sure the receiver is not tuned to a station. Next, with the Model 230 tuned to the correct frequency, check for rf voltage across the various rf bypass capacitors in the rf and i-f circuits. No appreciable rf voltage should appear across a good by-pass capacitor. If you find that an rf or i-f voltage exists across some by-pass capacitor, that one is probably open and another capacitor should be tried.

In all probability, replacing a faulty by-pass capacitor will clear up the trouble. If not, check right through the receiver from the antenna to the second detector. Use the probe, and tune the signal tracer to the correct frequency, just as described for measuring gain in weak receivers. Oscillation in an i-f stage will usually be indicated by closure of the tuning eye with no signal being fed to the receiver. Since the oscillating stage will not be modulated, no sound will be heard in the loudspeaker of the Model 230.

Oscillation in the rf stage will usually be indicated by closure of the tuning eye of the Model 230 with no signal being fed to the receiver. As in the case of i-f oscillation, no sound will be reproduced by the loudspeaker of the Model 230. The frequency of the oscillation will depend on the dial setting of the receiver.

HOW TO SERVICE A NOISY RECEIVER

When a receiver is noisy, certain clues will lead directly to the noise source. (We are assuming that you have definitely concluded that the noise is originating within the receiver.) A change in noise level when you are actually moving the wave-band switch, a pushbutton switch, the volume control, the tone control, or the tuning capacitor, indicates that the device being moved is at fault. Even if you do not have any of these clues, the noise can be localized to one section rather simply.

In a modern superheterodyne receiver, the volume control is either the diode load resistor, or is in the input circuit of the first af stage. Therefore, the volume control separates the rf-af section from the audio section of the receiver. If you turn the volume control to the minimum volume position and the noise disappears, the source of the noise is in the rf-if section of the receiver. If the noise remains, with the volume control set at minimum, the source of the noise is in the audio amplifier section, or in the power supply of the receiver. (This is not quite always true. Severe changes in current, such as may be caused by a circuit defect in an rf or i-f stage, may affect the power supply to the audio amplifier enough to introduce noise -- even when the

volume control is turned to zero volume. However, in such cases, turning down the volume control will decrease the noise intensity greatly)

Noise signals pass through the receiver stages in the same way as other signals do. Their source can be readily located with the Model 230 Signal Tracer.

To trace noise signals with the signal tracer, tune the receiver and signal tracer to some quiet point on the dial (not to a station). Trace from the first stage of the defective section (rf-if section or af section) toward the loudspeaker of the set. When you first hear the noise coming from the signal tracer speaker, you have located the defective stage.

Remember that noises originating in one stage may feed back into a number of previous stages through a power supply circuit common to these stages. This can occur only when the noise signal is unusually strong, or in sets in which there is insufficient bypassing of the supply leads. Therefore, in rare cases, it is possible to pick up a noise signal in the output circuit of one stage when the noise is actually originating in a later stage. Short the output of the first stage in which noise is traced, using a .1-mfd capacitor. If the noise disappears in the receiver's output, this stage is more than likely introducing the noise. If the noise is still present in the receiver's output, suspect a following stage.

HOW TO SERVICE AN INTERMITTENT RECEIVER

The Model 230 Signal Tracer is ideal for localizing intermittent defects, but you should not use the signal tracer until you have tried the "brute force" method. This consists of wiggling individual parts and pulling on leads to parts while the receiver is operating. If, by doing this, you can make the intermittent defect occur, you have found the defective part or connection. In the vast majority of intermittent receivers, you can quickly find the cause of the trouble with this "brute force" method. When this method fails, use your signal tracer to localize the trouble to a section and then to a stage.

There is one important fact you should consider before you start to use your signal tracer (or any other piece of test equipment) to locate an intermittent defect. You must leave the equipment connected until the set "acts up." Therefore, your test equipment is tied up to this intermittent receiver. You cannot use it to service other sets while you are waiting for the defective set to "act up." For this reason, be sure to learn how often the intermittent

defect occurs before you start the job.

Use the signal tracer to isolate the intermittent stage or part. Leave the signal tracer connected to the receiver while you wait for the set to cut out. In between "cut-outs," you need pay little attention to the set. When you hear the set act up, a glance at the signal tracer indicator eye will show how much progress you are making in locating the trouble.

To attach your signal tracer probe to the receiver, you will need an alligator clip which can be slipped on the end of the probe. This clip is NOT furnished with the Model 230, as most servicemen have such clips. You can purchase a pair from your local parts distributor or a mail-order house. If possible, get an insulated alligator clip with phone tip jack attached. This will slip over the tip of the probe. Some semi-permanent connections of this sort are necessary when dealing with intermittent receivers, because touching a probe to a circuit while the receiver is intermittent may disturb the circuit enough to restore operation, thus defeating the purpose of the test.

HOW TO ALIGN RECEIVERS WITH THE SIGNAL TRACER

If a signal generator is available, it should be used for alignment purposes. However, the Model 230 signal tracer may be satisfactorily used to align a receiver. The signal tracer is used to align the i-f amplifier and also the broadcast preselector and oscillator sections. However, once the receiver i-f is properly adjusted, stations may be used for oscillator and preselector adjustment. To align the broadcast band of a receiver, proceed as follows:

1. Clip the probe to the output of the mixer. Clip the ground lead to B-.
2. Set the receiver dial to the frequency of a broadcast station in the neighborhood of 1400 kc, and tune the signal tracer to exactly the same frequency as the station. You should hear the station from the loudspeaker of the signal tracer. (Do not tune the signal tracer to the i-f frequency of the receiver.)
3. Block the oscillator of the receiver by shorting the oscillator section of the receiver tuning capacitor.
4. Adjust the receiver rf trimmer or trimmers for maximum closure of the signal tracer indicator eye. (If the indicator eye overlaps, adjust the attenuators for some indicator eye shadow.)
5. Tune the Model 230 to the i-f specified by the receiver manufacturer, remove the short across the oscillator tuning capacitor, and adjust the oscillator trimmer for maximum closure of the signal tracer indicator eye.

6. (If the oscillator is not equipped with a low-frequency adjustment such as a padder capacitor or variable slug in the oscillator coil, omit Steps 6, 7, and 8. Go immediately to Step 9.)

If the receiver has a low-frequency oscillator slug or padder capacitor, proceed as follows: tune the signal tracer to a station near 600 kc with the probe connected to the receiver antenna. Next clip the probe to the mixer output, block the receiver oscillator, and manually tune the receiver to this station, for maximum closure of the signal tracer eye.

7. Tune the signal tracer to the receiver's correct i-f frequency, as in Step 5, unblock the oscillator, and adjust the oscillator low-frequency padder capacitor or oscillator slug for maximum signal tracer indicator eye closure.

8. Tune the receiver to the station near 1400 kc and repeat the oscillator trimmer adjustment in Step 5. Now repeat Steps 6 and 7.

9. Move the probe to the circuit of the first i-f amplifier, and adjust the first i-f transformer trimmers for maximum signal tracer indicator eye closure. Repeat for the 2nd i-f stage if one is used.

10. Move the probe to the ungrounded side of the diode load resistor, adjust the attenuators for maximum signal tracer sensitivity. A small signal should be present. Adjust the output i-f transformer trimmers for maximum signal tracer indicator eye closure. This completes the i-f alignment.

SPECIAL INFORMATION

1. The noise heard when the fine attenuator is turned past 1 does not indicate that this control is noisy. This is natural and is due to the construction of the control.
2. If the Model 230 breaks into oscillation at any frequency, reduce its sensitivity by turning the fine attenuator control counterclockwise.
3. On very strong signals, do not allow the indicator eye to overlap, because blocking will then occur. Simply readjust the attenuators for proper eye closure - no damage will result.
4. With the function switch in the AF position, the tracer volume control is fed from the output of tube V_2 . However, there is a slight amount of power-supply ripple at the plate of this tube. If no signal is being examined, and the tracer volume control is tuned to maximum, some hum will be heard coming from the speaker. This is a natural condition. If a signal is being traced and the attenuators are set for high gain, any residual hum will be overridden. Also overloading will occur before the

volume control could be advanced to the point where the hum was objectionable.

5. The Model 230 ground lead should always connect to B-. This is generally the receiver chassis. Where B- is not the chassis (an examination of the receiver diagram will show if this is true), the Model 230 ground lead should connect to B-. In practically every case B- may be taken to be the low-potential side of the volume control. This is the outside lug shown as being grounded in Figs. 17, 18, and 19. Although this point is easy to locate and clip to, any other point connected to it could be used. If you wish, an insulated wire may be temporarily soldered to B-, and the Model 230 ground lead clipped to the bare end of this wire. This will make it possible to turn the chassis over while signal tracing. The chassis is the ground-lead connection point in transistor receivers. On transistor sets using a printed circuit, the ground-lead connection point is the frame of the tuning capacitor or any part of the circuit directly connected to the tuning-capacitor frame.

Getting Maximum Selectivity. Since the Model 230 is a test instrument and not primarily a

radio receiver, selectivity is not judged by listening to the speaker output when tuning. On very strong signals, the attenuators should be kept as far counterclockwise as possible. Use the tuning eye indicator tube as a means of selecting or separating one signal from another.

MAINTENANCE

Your Model 230 Signal Tracer is constructed of quality parts and the instrument will ordinarily give years of trouble-free service before any maintenance is required. If trouble develops, service the instrument as you would any other piece of electronic equipment. Since tubes are the most likely cause of failure, test the tubes first. Remove the chassis from the cabinet and test the tubes.

CAUTION: WHEN THE INSTRUMENT IS TURNED ON, B+ VOLTAGE IS PRESENT ON THE STATIONARY PLATES OF THE TUNING CAPACITOR.

If the tubes test good, check the voltages given in the voltage chart, in Fig. 20. Instructions for taking these voltages are given on

TUBE	PIN NUMBER						
	1	2	3	4	5	6	7
V ₁ - 6AB4	215V DC	0	**	**	0	10V DC	48V DC
V ₂ - 6GM6	0	2V DC	**	**	190V DC 150V DC*	90V DC	0
V ₃ - 6GM6	0	1.7V DC	**	**	190V DC	115V DC	0
V ₄ - 6X4	200V AC	NC	**	**	NC	200V AC	240V DC
V ₅ - 6AV6	-.8V DC	0	**	**	-.9V DC -.6V DC*	-.5V DC -.9V DC*	110V DC
V ₆ - 6E5	**	45V DC	-.8V DC	215V DC	0	**	--
V ₇ - 6AQ5	0	12V DC	**	**	230V DC	215V DC	0

* RF-AF switch set at AF.

** The 6.3V AC filament voltage will appear on one of the filament pins in each tube; the other filament pin in each tube will read 0.

NC No connection.

FIG. 20. Voltage chart for the Model 230. These voltage readings were taken with a vtvm. Your voltage readings can normally be expected to vary $\pm 20\%$ from these because of parts tolerances and variations in individual tube characteristics. For taking the readings, clip the ground lead of the signal tracer to the probe tip, and set the controls as follows:

Fine Attenuator at 1:

Coarse Attenuator at 1.

Band Selector at either A or B.

Volume control at any position.

RF-AF control at RF, except for readings marked *; for these, set at AF.

Tuning knob at any position.

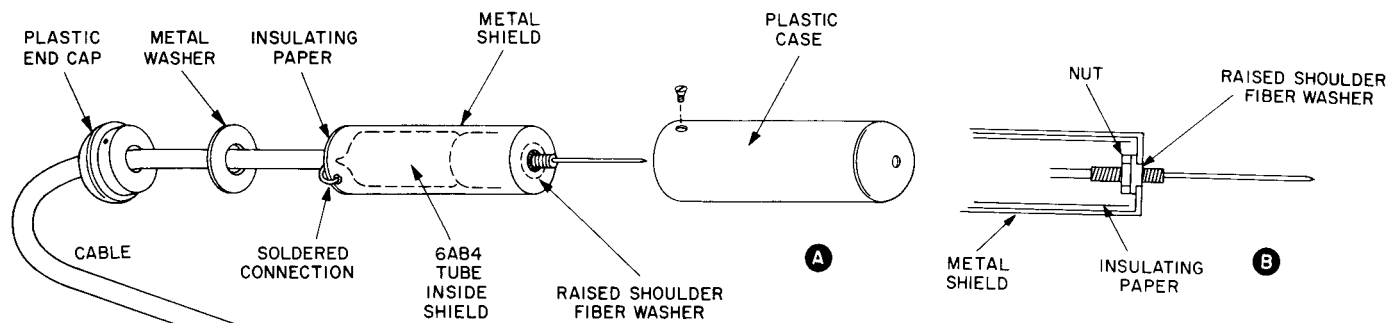

FIG. 21. (A) The probe with its plastic case removed; (B) cross sectional view, showing position of fiber washer, nut, and insulating paper inside the metal shield.

the chart. When you find a voltage that varies widely from the values given in the chart, check the components in that area. Use the schematic diagram in Fig. 16, to help you analyze the trouble.

To determine if the trouble is in the probe, proceed as follows: With the chassis removed from the cabinet, turn the instrument on. Set the RF-AF switch to AF. Turn the volume control to 5. Touch the control grid (pin 1) of V_2 . This injects hum pickup into the amplifier and should produce a loud hum from the speaker. If no hum is produced, the trouble is in the amplifier and the probe is probably all right. If you can produce a hum by touching the control grid (pin 1) of V_2 , try touching the probe tip. If touching the probe tip does not produce a hum the trouble is probably in the probe.

Disassemble the probe to remove and test the 6AB4 tube in the probe. Refer to the exploded view of the probe, Fig. 21, to identify the parts in the probe. Remove the rear plastic end cap from the plastic case by loosening the screw holding the cap in place. Slide the cap a foot or so down the probe cable so it is clear of the probe. Slide the flat metal washer out of the probe; the washer may come out with the end cap. Clamp the metal probe tip in a vise or grasp it firmly with a pliers. Then unscrew the plastic case from the probe tip. The case must be turned counter-clockwise looking at the probe tip. When the plastic case clears the threads on the probe tip, remove the tip from the vise and slip the case off the tip end of the probe. Carefully unsolder the ground wire connection to the metal shield. Note the

position of the raised shoulder fiber washer that insulates the metal case from the probe tip. Remove the metal case, insulating paper (the paper should stay inside the metal shield), and the fiber washer. Do not move the nut next to the fiber washer. You can now get at the 6AB4 tube and the electrical components in the probe.

Reassemble the probe in the reverse order of the steps for disassembly. Be sure to position the fiber washer so that it insulates the metal shield from the metal probe tip.

If you cannot locate the trouble in your signal tracer yourself, write us a letter describing the trouble you are having. Include a voltage chart showing the readings that you get on your instrument. We will try to send you the information you need to get your instrument working.

If, after the warranty period has expired, a defect develops in your instrument that you are unable to repair yourself, you may return it for repair for which there is a minimum charge of \$7.50 plus the cost of any parts. This minimum charge is necessary to cover the cost of handling, inspecting, and making minor repairs. If you return the instrument to us for repair, write us a letter telling us that the instrument is on the way and describe fully the difficulty you are having. Enclose the \$7.50 minimum charge. Send check or money order. Do not send cash. Pack the instrument in a sturdy carton and fill the open spaces with shredded newspaper. Ship the instrument to us by prepaid express. We will return it to you by express collect.

K4XL's **BAMA**

This manual is provided **FREE OF CHARGE** from the “BoatAnchor Manual Archive” as a service to the Boatanchor community.

It was uploaded by someone who wanted to help you repair and maintain your equipment.

If you paid anyone other than BAMA for this manual, you paid someone who is making a profit from the free labor of others without asking their permission.

You may pass on copies of this manual to anyone who needs it. But do it without charge.

Thousands of files are available without charge from BAMA. Visit us at <http://bama.sbc.edu>