

## HOW TO USE YOUR CONAR MODEL 211 VTVM

The Conar Model 211 VTVM is a high-quality service-type instrument used for the course experiments, for Radio-TV service work, and for electronic maintenance work. In your experiments you learn to calibrate the instrument, read the scales, and take different kinds of measurements. The operating instructions are spread over a number of manuals so this information is for easy reference.

After you install the 6X4 tube included in Kit 3Y, you will be able to measure ac voltages as described.

There are certain precautions to observe in making any type of voltage measurement. The most important is to set the Range Switch on a value that is greater than the voltage being measured. There is little danger of actually burning out the meter. However, if the Range Switch is in a low-voltage position and you apply a high voltage to the input of the vtvm, the meter pointer may be bent when it is slammed against the extreme right-hand side of the scale. If you are not sure how high the voltage in the circuit should be, set the Range Switch to 1200V before touching the probe to the test point. If the meter pointer moves less than one-quarter of full scale, turn the Range Switch to the next lower position. Keep repeating this procedure until you get a meter indication that you can easily read.

Observe personal safety precautions to keep from getting an electrical shock when making any type of voltage measurement. Hold the probe by the insulated handle when you touch the probe tip to a point in an energized circuit. Be careful not to touch the metal part of the probe with your hand. Take special care when clipping the vtvm ground clip to a point in the circuit. Since you must touch the metal clip to open the jaws, it is always safer to unplug the equipment under test when you attach this ground clip. If you are going to just touch the ground clip to a point in an energized circuit, you can hold the clip by the insulated handle.

**IMPORTANT:** We urge you to learn how to use your vtvm before you do Radio and Television service work with it. It would be better for you to wait until you finish the experiments in all the kits before becoming involved in too much service work. Get as much practice as you can taking all kinds of voltage and resistance measurements and learn how to read the meter scales.

### CALIBRATION

Before calibrating the vtvm, you should check the mechanical zero of the meter movement. To do this, set the vtvm on a level work space and turn it off or leave it unplugged. The pointer should be exactly on the zero mark on the left end of the scale. If it is not, adjust the pointer to zero by moving the plastic screw in the center of the meter face. Use a screwdriver that fits the slot in the plastic. The instrument is now ready for electrical calibration. Locate the calibration controls on your vtvm by observing the labeled controls in Fig. 1.

**DC Calibration.** Turn the instrument on

and let it warm up for at least 5 minutes. Set the Function Switch to the +DC position and the Range Switch to the 3V position. Then, adjust the Zero set control on the front panel until the meter pointer is exactly over 0 on the left side of the meter scale. Touch the red probe to the positive terminal of the flashlight cell mounted on the chassis. Place the ground clip so that it does not touch the meter chassis or any other part. The meter pointer should move to 1.5 on the black 3V meter scale. If it is not exactly over 1.5, bring it over 1.5 by adjusting the calibration control.

The output of a new flashlight cell in good condition is 1.55 volts. If you know that the cell is new and in first class condition, you can set the pointer to 1.55 volts. However, the setting of 1.5 volts will give sufficient accuracy for all measurements.

Remove the probe from the flashlight cell terminal and note if the pointer returns exactly to zero. If it does not, reset it to zero with the Zero set control. Readjust the calibration control until the pointer is exactly over the 1.5 volt division on the scale when the probe is touched to the positive terminal of the flashlight cell and will return exactly to zero when the probe is removed.

Your vtvm is now calibrated for both dc and ac voltage measurements on all ranges, but one more adjustment is necessary before making ac measurements.

**AC Zero Adjust.** Set the Function Switch to AC and the Range Switch to 3V. Attach the ground clip to the probe. Set the pointer to zero with the AC zero adjust. When the test leads are separated after this adjustment, the meter pointer may move up-scale (off zero.) Ignore this; do not readjust. The reading is due to ac pickup by the probe caused by the high input impedance of the vtvm. When the leads are connected to a voltage source, the low impedance of the source will prevent this ac pickup from affecting the reading.

Your vtvm is now ready to take ac voltage measurements on all ranges.

**Ohms Calibration.** The zero set should be accurately adjusted on dc before performing the Ohms calibration. Set the Function Switch to +DC and the Range Switch to 3V. Check to see that the pointer is exactly on zero. Move the Function Switch to ohms and separate the

test leads. The meter pointer should move up-scale to the last mark on the right-hand end of the scale. If it does not, set the pointer to the last mark on the right-hand end of the Ohms scale by adjusting the Ohms set control. Touch the probe to the ground clip and observe that the pointer moves to nearly zero on the left-hand side of the Ohms scale. A reading of a fraction of an ohm is normal. The reading indicates the low resistance of the probe lead and the ground lead. Do not hold the probe and ground lead together for any length of time, as this places a load on the dry cell, particularly on the R × 1 range.

The vtvm is now properly calibrated so that it will indicate correctly on +DC, -DC, AC, and OHMS.

### +DC VOLTAGE MEASUREMENTS

You will probably use the +dc voltage section of your vtvm more than any other. You will use it to measure the output of power supplies and dc voltages at various points in electronic circuits.

The Function Switch is set to +DC for taking +dc voltage measurements. All dc voltages are read on the black scale labeled DC-AC and numbered 0 to 3.0 and 0 to 12. This is the second scale from the top as shown in the close-up view of the scales in Fig. 2. The setting of the Range Switch determines which set of numbers to read on the scale.

The following is a brief description of how to use each of the dc voltage ranges.

DC voltages up to 3 volts: Range Switch on 3V. Read the scale as .5, 1, 1.5, 2, 2.5 and 3. Each small division is .05 volt.

DC voltages up to 30 volts: Range Switch on 30V. Ignore the decimal point and read the scale as 5, 10, 15, 20, 25, and 30. Each small division is .5 volt.

DC voltages up to 300 volts: Range Switch on 300V. Ignore the decimal point and mentally add a zero to the scale reading. Read the scale as 50, 100, 150, 200, 250, and 300. Each small division is 5 volts.

DC voltages up to 12, 120, or 1200: Read black 0-12 scale.

DC voltages up to 12 volts: Range Switch on 12V. Read scale directly. Each small division is .2 volt.

DC voltages up to 120 volts: Range Switch on 120V. Mentally add a zero and read the scale as 20, 40, 60, 80, 100 and 120. Each small division is 2 volts.

DC voltages up to 1200 volts: Range Switch on 1200V. Mentally add two zeros and read scale as 200, 400, 600, 800, 1000, and 1200. Each small division is 20 volts.

When the pointer does not read exactly over one of the numbered divisions of the scale, read the last numbered division to the left of the pointer. To this reading add the value of the small divisions between the numbered division and the pointer. To this total add the value of the fractional part of the last small division if the pointer rests between two of the small divisions.

Example: Suppose the Range Switch is at 3V, and the pointer is approximately  $\frac{2}{5}$  of the distance between the second and third small divisions to the right of 1.5 on the



FIG. 1. Model 211 VTVM showing the calibration controls.

black 3V scale. Read 1.5. To this add the first and second small divisions. Each division represents .05 volt.  $1.5 + .05 + .05 = 1.6$ . To this total add  $2/5$  the value of the third small division.  $2/5$  of .05 is .02.

$$1.6 + .02 = 1.62$$

Generally your readings do not have to be this precise. In the above example, an estimate of 1.6 is satisfactory.

#### -DC VOLTAGE MEASUREMENTS

To measure - dc voltage with your Model 211 VTVM, turn the Function Switch to the -DC position. Then you can use the vtvm to measure -dc voltages from zero to 1200 volts, using the same meter scale and the same multiplying factors as you used for +dc measurements.

#### AC VOLTAGE MEASUREMENTS

Your Conar Model 211 VTVM is an extremely sensitive electronic ac voltmeter. You have probably noticed that with the meter set for AC and the Range Switch in the 3V position, the meter will indicate voltage when you touch the metal tip of the probe with your finger. This is because your body picks up ac from nearby wires that are carrying ac voltage. Always hold the vtvm probe by the insulated handle when taking readings. This is not only a safety precaution but also prevents ac pick-up from affecting your meter readings.

When the Range Switch is in the 3V position and the Function Switch is set to AC, the voltage must be read on the special red 3V ac scale. Remember to use this red scale instead of the black scale. The red scale is used only for ac voltages up to 3 volts.

For ac voltages higher than 3 volts, use the combination black scales labeled AC-DC in the same way as for dc voltages. Use the same multiplying factors and the same Range Switch positions. For example, when measuring ac voltage on the 30V range, you read the black 0 to 3.0 scale and multiply the meter indication by 10.

Regardless of the type of ac measurement you make, be sure to choose the proper voltmeter range. Set the Range Switch to the 1200V position before connecting the test leads if you don't know how much voltage there should be in the circuit. Then switch to the lower ranges to get a usable meter indication.

**CAUTION:** The vtvm cannot be used to measure ac voltages higher than 600 volts. If you find it necessary to measure the output of a transformer high voltage secondary winding, measure the voltage between the center tap and one end of the winding. Then measure between the center tap and the other end of the winding. Add the two voltages together to get the total output voltage of the high voltage secondary.

#### PEAK-TO-PEAK VOLTAGE MEASUREMENTS

Your Model 211 VTVM has peak-to-peak scales for conveniently converting ac voltage readings to their equivalent peak-to-peak values. The red scale labeled P-P and numbered 0-8 is used to convert ac readings between 0 and 3 volts to the equivalent peak-to-peak value. For example, an ac voltage of 2.4 volts on the red 3V ac scale is converted to about 7 volts peak-to-peak read on the red P-P scale.

The black scale labeled P-P and numbered 0-8 and 0-32 is used with the black AC-DC voltage scale. Of course, all peak-to-peak readings are taken with the Function Switch at ac. Set the meter up to read the ac value of the voltage applied to the vtvm. Then convert the reading to the peak-to-peak value by reading on the appropriate P-P scale.

For ac voltages between 0 and 30 volts on the ac-dc scale, the equivalent peak-to-peak value will be between 0 and 80 volts peak-to-peak read on the black 0-8 P-P scale.

For ac voltages between 0 and 300 volts on the ac-dc scale, the equivalent peak-to-peak value will be between 0 and 800 volts peak-to-peak read on the 0-8 P-P scale.

For ac voltages between 0 and 12 volts on the ac-dc scale, the equivalent peak-to-peak value will be between 0 and 32 volts peak-to-peak read on the 0-32 black P-P scale.

For ac voltages between 0 and 120 volts on the ac-dc scale, the equivalent peak-to-peak value will be between 0 and 320 volts peak-to-peak read on the 0-32 black P-P scale.

For ac voltages between 0 and 1200 volts on the ac-dc scale, the equivalent peak-to-peak value will be between 0 and 3200 volts peak-to-peak read on the 0-32 P-P scale.

**CAUTION:** Remember that you should not measure ac voltages above 600 volts which gives a peak-to-peak reading of over 1600 volts.

#### RESISTANCE MEASUREMENTS

There are certain precautions to take in

using an ohmmeter. NEVER TRY TO MEASURE RESISTANCE WITH POWER APPLIED TO THE CIRCUIT UNDER TEST. There is danger that you will damage the meter. At the least, your meter indications will be inaccurate. Also keep your fingers away from the metal ends of the ground clip and probe, because the meter will indicate your body resistance. This can cause considerable variation and error in the measurement of high resistance values.

With the Range Switch set at  $R \times 1$ , read the resistance value directly on the OHMS scale. This is the top scale in Fig. 2. When the Range Switch is in the  $R \times 10$  position, the meter indication must be multiplied by 10 to get the resistance of the part being tested.

The letter K is used to represent 1000. For example, with the Range Switch set at  $R \times 1K$  position, the meter indication must be multiplied by 1000. The multiplying factor for the  $R \times 10K$  range is 10,000. The multiplying factor for the 100K position is 100,000. The final range is marked 1M, which means 1 megohm. Here the meter indications can be read directly in megohms without any multiplication.

Always choose a range that gives a meter indication somewhere near the center of the ohmmeter scale. Of course, you will not always be able to get a meter indication near the center. However, if you do find that the resistance indication is near the extreme end of the scale, try the next higher or lower range to see if the indicated value is nearer the center of the scale.

#### USING THE VTVM TO CHECK A RECEIVER

The following discussion illustrates the use of your vtvm for checking and troubleshooting a typical ac-dc radio receiver. You will get detailed instructions in your experiments on all phases of using your vtvm. Again, we urge you to complete your training in the experiments before attempting service work.

**Measuring Operating Voltages.** First, we will outline the procedure in measuring the plate, screen, and bias voltages being applied to the 50C5 audio amplifier stage in an ac-dc set. The procedure for measuring the electrode voltages would be the same for any stage in a receiver, but the number of electrodes in the tubes may vary and they may be connected to different tube socket pins. When servicing a receiver, therefore, use the schematic diagram of the set, if one is available, or use a tube manual to identify the electrode

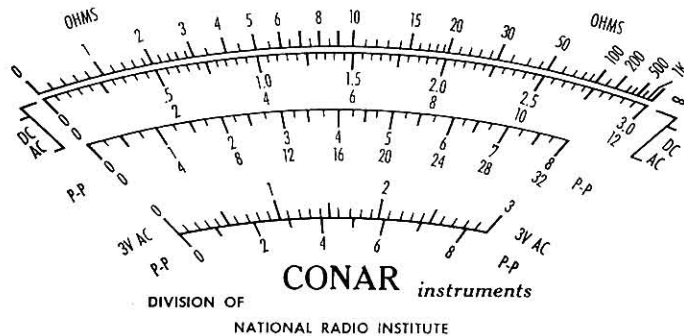

FIG. 2. Here are the scales on the meter of the VTVM.

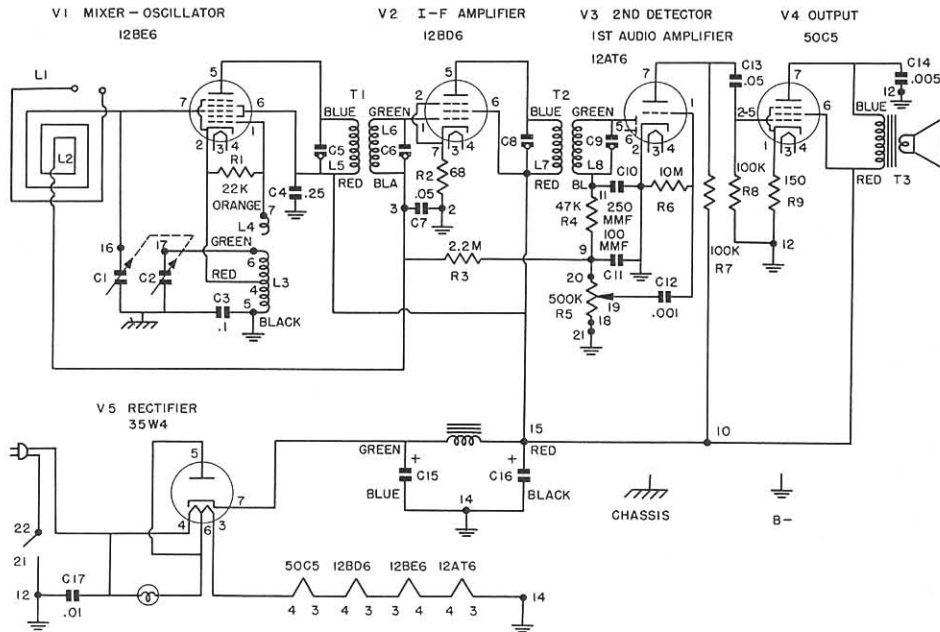

FIG. 3. Schematic diagram of a typical ac-dc radio receiver.

connected to each of the tube socket pins.

The schematic diagram of a typical ac-dc receiver is shown in Fig. 3. The correct procedure for measuring the voltages in the 50C5 tube stage is outlined below:

(1) Remove the receiver power cord plug from the power outlet.

(2) Connect the ground lead of the vtvm to the set side of the On-Off switch. This is switch terminal 21 that connects to terminal 12 and B-.

(3) Turn the Function Switch to +DC and the Range Switch to the 300V position.

(4) Plug the receiver into a power line outlet, turn the set on, and allow about thirty seconds for the tubes to reach operating temperature.

(5) To measure the plate voltage on the 50C5 tube socket, refer to Fig. 3. You will see that the plate is pin 7. Holding the probe by the insulated handle, touch the probe tip to socket pin 7. The meter will indicate the amount of voltage on the plate.

In an ac-dc receiver of this type, you will probably find that the plate voltage is less than 120 volts. The plate voltage on a similar stage in an ac-operated receiver would be considerably more. If you find that your plate voltage is less than 120 volts, remove the tip of the probe from pin 7, and change the Range Switch setting to the 120V position. Again touch the probe tip to pin 7, and note the voltage reading. Most of the servicing information supplied by the receiver manufacturer lists the normal voltage values applied to each tube electrode. By comparing your measured values with those given in the service sheet, you can tell quickly whether or not they are acceptable.

(6) Measure the screen grid voltage on the 50C5 tube by moving the probe to pin 6 of the tube socket. Leave the ground clip connected to the set side of the On-Off switch.

(7) The next dc voltage that you would measure is the bias voltage. In most ac-dc

sets, you can find the bias voltage by measuring the voltage across the cathode resistor. If you were servicing the receiver shown in Fig. 3, you would leave the ground lead connected to B-, and touch the probe to pin 1 of the 50C5 tube socket. Since this voltage will be considerably less than the screen voltage, you will have to change the Range Switch setting.

You have now measured the plate, screen, and bias voltages in one of the receiver stages. Use this same procedure in all stages of an ac-dc set. All you need to know is which tube electrode connects to which tube socket pin. You can get this information from the schematic diagram of the receiver or from a tube manual.

Switch the Function Switch to the -DC position and measure the avc voltage. You can measure the avc voltage at terminal 3 in Fig. 3. Since this voltage will be a small negative value, switch the Range Switch to a low range. You will have to tune in a station on the receiver to get an appreciable reading. Notice that you can get maximum avc voltage when the set is tuned exactly to the station. Also notice that strong stations produce more avc voltage than weak stations.

Check to see if the local oscillator is operating by measuring the oscillator bias voltage at pin 1 of V1, the 12BE6 tube. If the local oscillator is oscillating, a sizable negative voltage will develop at pin 1. Set the Function Switch at -DC and the Range Switch at a low range. Touch the probe to pin 1 of V1. You should get about -8 volts or more. A zero or positive reading indicates that the oscillator is not operating.

The procedure used to measure dc voltages in receivers having a power transformer is slightly different from that used in ac-dc sets. You do not have to disconnect the power cord from the outlet when you connect the vtvm ground clip. The set can be turned on when you start the measurements. Just con-

nect the ground clip at some convenient point on the chassis and touch the probe to the points in the receiver in which you are interested.

To demonstrate how to take the dc electrode voltage tests in this type of receiver, we will use a pictorial diagram with the parts positioned exactly as they would appear in an actual set. The diagram in Fig. 4 shows the first audio and the audio output stages of a typical television receiver. In this discussion, we will be concerned only with the output stage. Notice that the tube socket pins are numbered, but you have no way of knowing which tube electrode connects to which pin. To find out, you would look in a tube manual and find the tube basing diagram for a 6AQ5 tube, similar to the one shown in Fig. 5. You can purchase a tube manual from any radio wholesale store.

Now, refer to the diagram in Fig. 5 and identify the various tube electrodes. Notice that the plate is connected to tube socket pin 5, the screen grid to pin 6, the control grid to pins 1 and 7, and the cathode to pin 2. Now that you know the electrode connections at the tube socket, you can easily measure the electrode voltage in the same way as you did in the ac-dc receiver.

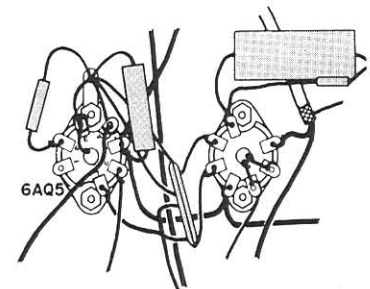

FIG. 4. First audio and audio output stages of a typical television receiver.

To measure ac power supply and filament voltages, you connect the meter test leads directly across the line cord leads, or between the filament pins of each tube socket. For example, you would measure between pins 3 and 4 of any of the tubes in the set shown in Fig. 3. Hold the clip by the insulated handle, and touch it to one of the tube socket pins connected to the tube filament. Then, touch the probe to the other tube socket pin. Be sure the Range Switch is on the proper setting.

AC signal voltages are usually measured between B- and the plate and control grid electrodes of the tube. Regardless of the type of ac measurement you make, be sure to choose the proper voltmeter range. Set the Range Switch to the 1200V position before connecting the meter test leads if you don't know how much voltage there should be in the circuit. Then, switch to the lower ranges to get a usable meter indication.

The ohmmeter section of your vtm is useful in servicing radio and television receivers. It can be used to check for continuity in coils and transformers, and to check for leakage and shorts in capacitors, as well as for measuring the values of resistors.

When the resistor that you are checking is

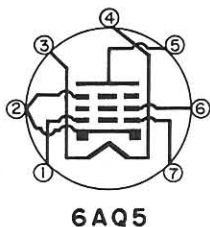

FIG. 5. Diagram of a 6AQ5 tube.

in a receiver circuit, it is usually advisable to disconnect one of the resistor leads from the rest of the circuit wiring, so you are actually measuring the resistance of the resistor itself, rather than a shunt path in the circuit.

In checking capacitors, the test procedure and the results depend on the kind of capacitor being tested. Paper and mica capacitors in good condition block the flow of direct current, provided the voltage applied to them does not exceed their rated breakdown voltage. Electrolytic capacitors will permit a small amount of dc current to flow through them. Furthermore, electrolytics are polarized, so when their resistance is measured, the ohmmeter must be connected with the proper polarity -- the probe to the positive capacitor lead, and the ground clip to the negative capacitor lead.

Since paper and mica capacitors block the flow of dc, you will get only a momentary movement of the meter pointer, or perhaps no movement at all, as you connect the test probes to the leads of a good capacitor. Any slight movement is due to the charging of the capacitor as the ohmmeter battery voltage is applied to it. After the capacitor becomes charged, the current stops flowing, and the pointer drops back to the right-hand side of the scale.

In checking an electrolytic capacitor, however, you will notice that the meter pointer will move considerably farther to the left, and that it will take a much longer time to charge the capacitor. The rate of charge will depend upon the setting of the Range Switch -- the lower the Range Switch setting, the more rapidly the capacitor is charged.

You will almost always measure a small amount of leakage even in a good electrolytic capacitor. This does not mean that the part is bad. In fact, some leakage is normal. Usually this type of capacitor is considered good if

its leakage resistance is 100,000 ohms or more.

Let us see how to check one section of the 20-20 mfd electrolytic capacitor in the filter circuit in Fig. 3.

First, you would unplug the receiver from the power line. Then you would disconnect one lead of the capacitor from the circuit. If you tried to check C15 without disconnecting one of its leads, you would not get an accurate indication of its condition, because there is a shunt path through the other capacitor section, marked C16, and the various bypass capacitors, such as C4 and C14. Therefore, to measure the resistance of C15, you would disconnect the capacitor lead from tube socket terminal 7 of the 35W4 tube socket, connect the probe to the capacitor lead, and the ground clip to terminal 14.

When you make the connection, the meter pointer will move across the scale to the left. Then, the pointer will gradually move to the right. Since electrolytic capacitors usually have a large capacity, they take some time to charge up. The meter pointer will take a corresponding length of time to drop back to the right after its initial movement to the left. This action is normal. Watch the pointer move up-scale and if the final reading is above 100,000 ohms, you would consider the capacitor to be good.

The parts in the other receiver circuits can be checked in the same way. Disconnect one of the leads, and measure directly across the part.

We have described how to take many types of measurements with the vtm. However, merely reading about how to use the instrument is not enough. You must take measurements with it at every opportunity. The more practice you get in using the instrument, the easier it will be for you to read the meter and take the various measurements.