

The Gap Resonated HF Loop

The small gap resonated HF loop is popular for portable QRP operations. In the previous Ionospherica we explored the bent dipole near the ground, and how its fields couple to the ground and to the ionosphere. This time we’ll take on the small loop near the ground. The loop is often thought to be a purely magnetic antenna, but it can have a very strong electric near field as well as a strong magnetic field. We confine our discussion to small loops, those less than one-tenth of a wavelength in diameter, and resonated by a capacitor in the loop gap.

We will look at the near fields of the loop, how it couples to the ground compared to a dipole, and how it couples to the ionosphere.

Figure 1 shows a portable ham radio operator using a small loop. HF loops, are typically about 1 m in diameter, incorporate a tuning-resonating capacitor and some sort of feeding mechanism, which can take the form of a secondary feeding loop or a shunt feeding arrangement. The loop and capacitor form a high- Q resonant circuit where the “beneficial” loss is radiation resistance. Measuring the Q and performance of a small HF loop are discussed in [1].

Loop near field analysis is very complex. Necessarily, this will involve some equations, but we’ll keep them to a minimum and as uncomplicated as possible! We’ll look at some specific results, including close electric near field expressions that are not readily available elsewhere.

The Close Near Fields of Small Loops

According to derivations in [2], the loop current $I(\phi)$ around the circumference ϕ of the electrically small loop is not constant, but has a ϕ dependency,

$$I(\phi) = I_0 (1 - 2(kb)^2 \cos(\phi)) \quad (1)$$

where I_0 is the loop feed current, b is the loop radius, and $k = 2\pi/\lambda$. Everywhere on the loop of wire radius a the surface tangential magnetic field is,

$$H_{surface} = \frac{I(\phi)}{2\pi a} \quad (2)$$

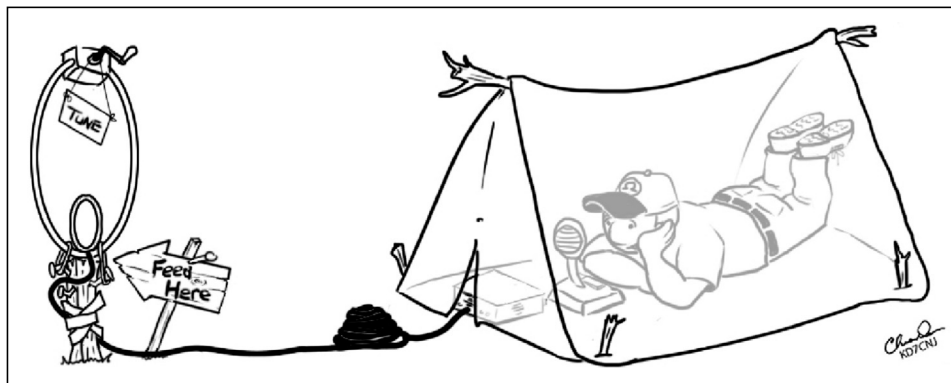

Figure 1—The small gap resonated loop fed by a secondary loop makes a compact portable HF antenna for QRP expeditions. *Source: ©2014 Chris Dean, KD7CNJ, used with permission.*

The current correction term in Eq (1) that depends on ϕ is the first term of a Fourier series expansion of the exact loop current, and is usually ignored. This term, however, results in a charge accumulation on the loop, and that in turn gives rise to an impressive close-near electric field.

The electric fields near the loop are very complex and very difficult to calculate analytically, however at the center $(x,y) = (0,0)$ of a small loop in the x - y plane (see Figure 2) the result is remarkably simple,

$$E_{0,0} = -j \frac{\eta_0 k I_0}{2} \quad (3)$$

where $\eta_0 = 376.7 \Omega$. Note that the electric field at the loop center does not depend on any loop dimensions (for an electrically

small loop). This electric field is y -directed, or horizontally polarized, inside the loop for a vertical loop oriented with the resonating capacitor at the top as shown in Figure 1. More on this later.

The magnetic field at the loop center, using classic solenoid analysis, is simply

$$H_{0,0} = \frac{I_0}{2b} \quad (4)$$

Unlike the electric field in the center, the magnetic field depends on the loop diameter $2b$. The wave impedance Z_w at the origin is the ratio of $E_{0,0}$ to $H_{0,0}$,

$$Z_w = -j\eta_0 kb \quad (5)$$

Since Z_w in the loop center is not zero, the small gap-resonated loop is clearly not

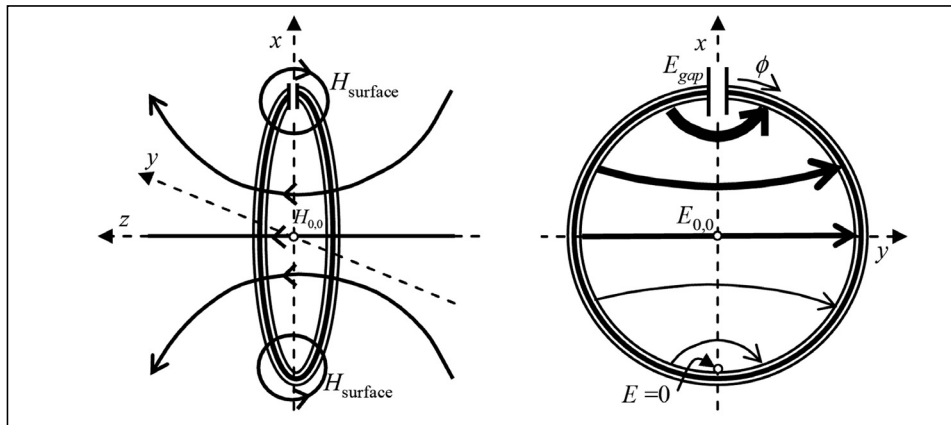

Figure 2—The (left) solenoidal magnetic fields on the loop surface ($H_{surface}$) and in the center ($H_{0,0}$) are easily determined. The (right) electric fields at the center ($E_{0,0}$), the gap (E_{gap}) and opposite the gap ($E = 0$) are also easy to determine.

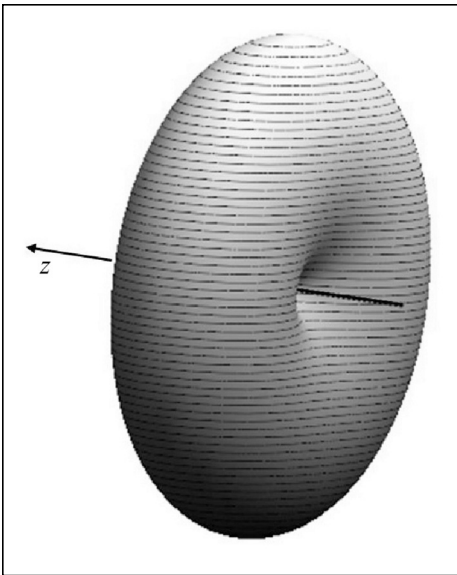

Figure 3—The magnetic far field of a vertical loop is solenoidal. Its electric far field wraps around the z-axis and is vertically polarized near the horizon.

a purely magnetic antenna, and in this orientation its close near-field polarization is at right angles to the far field polarization!

In addition to providing insight into the behavior of small loops, equations (1) to (5) are useful for validating the results of numerical electromagnetic code (NEC) computations.

We can easily find the exact electric field at three specific places inside the small loop: $E_{0,0}$ (Eq 3) at the loop center, E_{gap} across the gap-capacitor, and opposite the gap, where $E = 0$. The electric field at the gap-capacitor is easy to find from the rms capacitor voltage,

$$V_{cap} = \sqrt{X_C Q_L P} \quad (6)$$

where X_C is the capacitor reactance at resonance, Q_L is the loaded Q of the system [1], and P is the power radiated by the loop so,

$$E_{gap} = \frac{V_{gap}}{g} \quad (7)$$

where g is the gap dimension. V_{gap} can be almost 1 kV peak at QRP power levels.

An important take-away here is that there can be an enormous electric field near the small loop whose origin is the slight departure from a constant loop current seen in Eq (1). That field is of great interest when we assess RF exposure from a small HF loop.

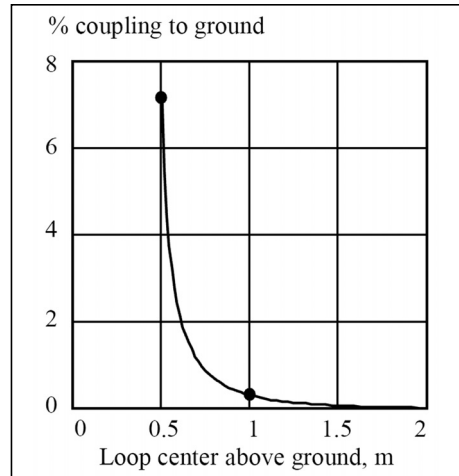

Figure 4—Loop field coupling to the ground vs. height of the loop center in meters.

Loop Far Fields

In the orientation of Figure 1, with the plane of the loop perpendicular to the ground, the far magnetic field pattern (see Figure 3) is toroidal. A slice through the y-z plane (parallel to the ground) has a figure-eight pattern, with nulls directed along the z-axis, the same as that of a horizontal dipole oriented along the z-axis. The loop electric far field wraps around the z-axis and is vertically polarized near the horizon.

Coupling to the Ionosphere and Earth

The loop radiation pattern null on the z-axis becomes less prominent and the pattern more omni-directional as the radiation angle relative to the ground increases. This means that loop radiation will couple in all directions into the ionosphere at the 5 to 20 degree elevation angles that are important to DX communications.

Although the electric field inside the loop is horizontally polarized, far from the loop (more than a few wavelengths) the electric field has only a E_θ component, so the polarization is vertical at angles near the horizon!

Small loops couple weakly to the ground, as seen in Figure 4. The mutual inductive coupling to ground for the 1 m diameter loop is 7% when resting just above a perfect ground, and only 0.34% when the center is 1 m above ground. This is far less than the coupling to ground of a horizontal dipole at the same height. I based my calculations on Neumann's integral formula for coupling between a loop and its image in a perfect ground. For the

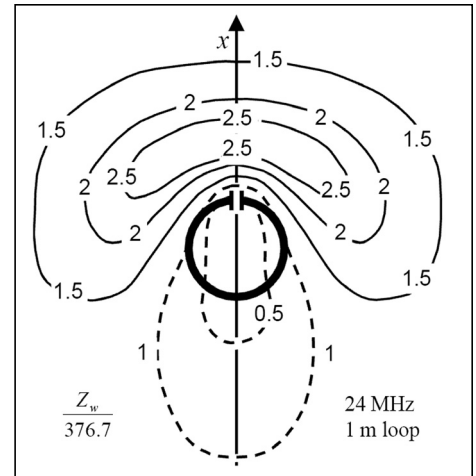

Figure 5—The electric field energy exceeds the magnetic field energy when the field impedance $Z_w/376.7$ exceeds 1 (solid contours).

QRP operator this means that the loop tuning will not be perturbed very much by changes to the height above ground.

Loop RF Safety

With just 10 W RF power the voltage on the loop at the tuning capacitor peaks out at nearly 1 kV peak, (multiply Eq (6) by 1.41), and is a safety concern. At 10 W the FCC compliance distance for RF exposure, see [3], is between 1.3 and 1.5 m (<5 ft) from the loop center across 7-29 MHz. Figure 5 shows that the electric field near the loop may be of more concern than the magnetic field, especially on the capacitor side (top) of the antenna.

Enjoy QRP operation with your loop - safely!

References

1. A. Findling, K9CHP, and K. Siwiak, KE4PT, "How Efficient is Your QRP Small Loop Antenna?," *QRP Quarterly*, Summer 2012.
2. K. Siwiak and Y. Bahreini, *Radiowave Propagation and Antennas for Personal Communications*, Third Edition, Artech House, Norwood MA: 2007, Chapter 11.
3. E. Hare, W1RFI, *RF Exposure and You*, ARRL, Newington, CT, Table 17, p. 8.77, www.arrl.org/shop/.

Kazimierz (Kai) Siwiak, KE4PT, is an avid DXer who packs a DX-go-bag station on his travels. His technical writings appear in many publications. ●●