

SPECTECH

**ST450
Scintillation SCA
ST450-PC System**

Operating Manual

July 2001

Spectrum Techniques, Inc.



ST450 System shown with ST350 Counter and detector.

Model ST450

Introduction

The ST450 Scintillation SCA is a self-contained instrument for measuring energy specific gamma ray emission using a scintillation detector. The ST450 may also be used to interface a scintillation detector or photomultiplier and a multi channel or single channel analyzer. The basic unit provides the following features:

- High Voltage supply to power the detector or photomultiplier.
- Charge Sensitive Preamplifier
- Bipolar Shaping Amplifier to process the signal prior to analysis
- Adjustable Baseline Control
- Adjustable window Control
- Integral and Differential Modes

When combined with the Spectech ST350 Radiation Counter and a PC or Macintosh computer, the following features are added:

- Digital readout
- Preset Time
- Preset Counts
- RAMP mode for automatic Baseline incrementing
- Computer Control
- Data Storage

Other models of counter/timers that accept a positive logic input signal may be used by connecting them to the SCA output.

The ST450 is designed to operate either with **negative** anode signals directly from a detector or with **positive** output signals from an external scintillation preamplifier. Scintillation detectors and photomultipliers utilizing a negative high voltage supply are **not** compatible with the ST450. Normally the ST450 utilizes a MHV high voltage connector, but this may be substituted with a SHV high voltage connector on special order.

Specifications

Preamp In	Charge sensitive preamplifier for connecting to the anode output of the detector. This input is used for detectors with a simple voltage divider type tube base producing negative anode output signals.
Amp In	Direct input to the shaping amplifier, used for connecting an external preamplifier producing positive signals.
Amp Out	Positive leading bipolar output from the shaping amplifier for connecting to a multi channel analyzer or other external electronics. 0-10 volt range set by coarse and fine gain controls, 1 μ sec. peaking time.
SCA Out	Positive TTL compatible pulse output, 1.5 μ sec. duration.
ST350 In	Provides an interface to the ST350 via its GM tube connector for counting and remote baseline control.
High Voltage	200-1200 volt positive supply with 1mA maximum current capability. Fully regulated and controlled by 10-turn direct reading potentiometer. MHV and SHV connectors.
Power Input	16 volt AC from power module supplied.

Controls and Indicators

Power	Push button turns on power to unit and lights the indicator.
High Voltage	Push button turns on high voltage and lights the indicator.
H. V. Adjust	Direct reading 10-turn potentiometer sets high voltage output level, 200-1200 volts.
Coarse Gain	6 position rotary switch sets amplifier gain from 2X to 64X.
Fine Gain	10-turn direct reading potentiometer sets fine gain from 0.5X to 1.5X.
Baseline	10-turn potentiometer sets the baseline from 0% to 100%.
Window	1-turn potentiometer sets the window from 1% to 20%.
Activity	Indicates when pulses are being received and processed by the ST450.
Integral Mode	Push button switches between Integral and Differential mode and lights the indicator. When the Integral Mode is ON, the Window control is defeated and all counts from the Baseline setting to 100% are amplified and outputted.
External Scan	Push button switches the Baseline control from the Baseline dial on the front panel to the ST-350 IN connector on the rear panel and lights the indicator. the baseline is now controlled by the high voltage setting on the ST350.



ST450 Front Panel



ST450 Rear Panel

Connecting Peripherals to the ST450

Scintillation Detectors

Connect the anode (signal) output from the detector to the **Preamp In** connector of the ST450. Using the appropriate cable (MHV or SHV, depending on the detector), connect the **High Voltage** output from the ST450 to the detector's high voltage connection.

Multi Channel Analyzer

To use the ST450 with a multi channel analyzer, connect the ST450's **Amp Out** to the MCA's ADC (direct) input.

ST250 and ST350

To use the ST450 with the ST350 counter/timer or the ST250 rate meter, connect the ST450's **ST-350 IN** connector to the ST350/250's **GM TUBE** connector.

Other Counters and Tube Bases

Other counters used with the ST450 must have a TTL compatible input. Connect the ST450's **SCA OUT** to the counter's input. Some detector tube bases such as the Tennelec model TC155A incorporate a built-in preamplifier which takes its power from the high voltage supply. In this instance, the output signal from the preamplifier must be connected to the **AMP IN** connector on the ST450. Also, if an external preamplifier with a positive output signal is used, connect the preamplifier's output to the **AMP IN** connector of the ST450.

ST450 Calibration

The ST450 is normally calibrated using a CS-137 source with the Fine Gain set to 1.0, the Coarse Gain set to 8, the Baseline set to 66.2%, and the Window set to 5%. The High Voltage is then set to provide the maximum count rate at the SCA Out.

Calibrate the ST450 as follows (NOTE: a rate meter such as the ST350 or ST250 is required to perform this calibration):

1. Connect the detector to the ST450 as indicated above.
2. Place a CS-137 source in the well/tray of the detector.
3. Connect the ST350/250's **GM TUBE** connector to the **ST-350 IN** connector of the ST450. If using a rate meter with a TTL compatible input, connect it to the **SCA OUT** of the ST450.
4. Set the ST450's controls to the following settings:

Fine Gain:	1.00
Coarse Gain:	8
Baseline:	66.2%
Window:	20%
High Voltage:	ON
H. V. Adjust:	200 Volts
Integral Mode:	OFF
Ext Scan:	OFF
5. While monitoring the counts with a rate meter, slowly increase the detector's high voltage until the unit begins to count. Continue increasing the high voltage, the countrate should peak and then reduce somewhat. Continue adjusting the high voltage up and down until the peak countrate is obtained.
6. Set the Window to 10% and again, adjust the high voltage for the highest count rate.
7. Set the Window to 5% and adjust the Fine Gain to obtain the highest count rate. The Baseline control will now be calibrated to read directly in keV and the Window with set at 50 keV.

ST450 Operation

Single Channel Analyzer

Once the ST450 is calibrated with a detector, it may be used with the ST350 to isolate and count a specific energy peak. This is accomplished as follows:

1. Connect the ST350 to the ST450 as indicated in the **Connecting Peripherals to the ST450** section.
2. Turn the EXT SCAN switch OFF.
3. Set the Baseline control to the energy of the peak to be measured. At this setting, the ST450 will amplify and output only the counts in the energy peak. As the resolution of the detector varies with energy, it is always best to adjust the Window setting to the approximate width of the peak and using a check source of the specific isotope to be measured, readjust the Baseline control to obtain the maximum countrate.
4. Set a Preset Time and press Count. The ST350 will display the counts in the specified energy peak when counting is complete.

Cs-137 Spectrum

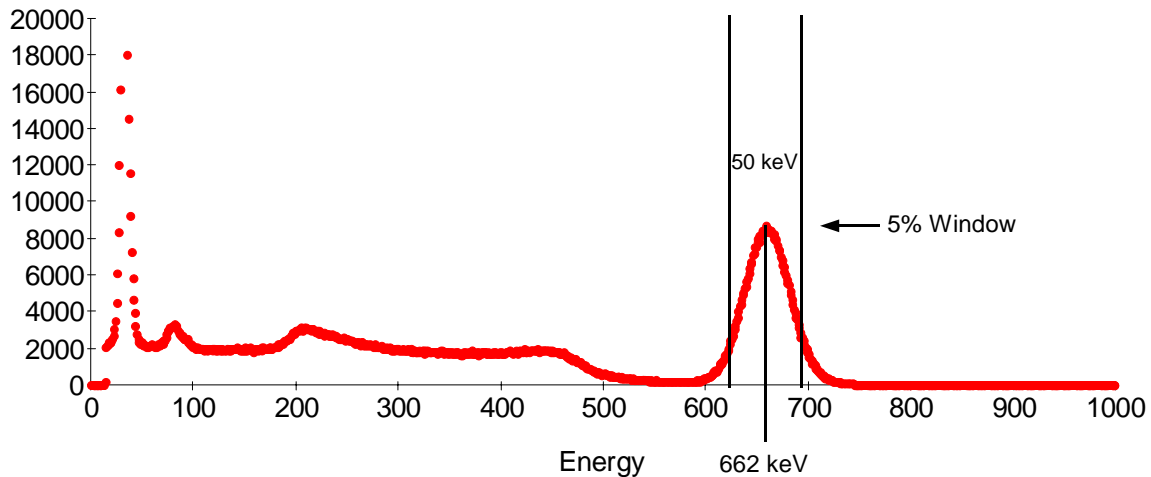

Co-57 Spectrum

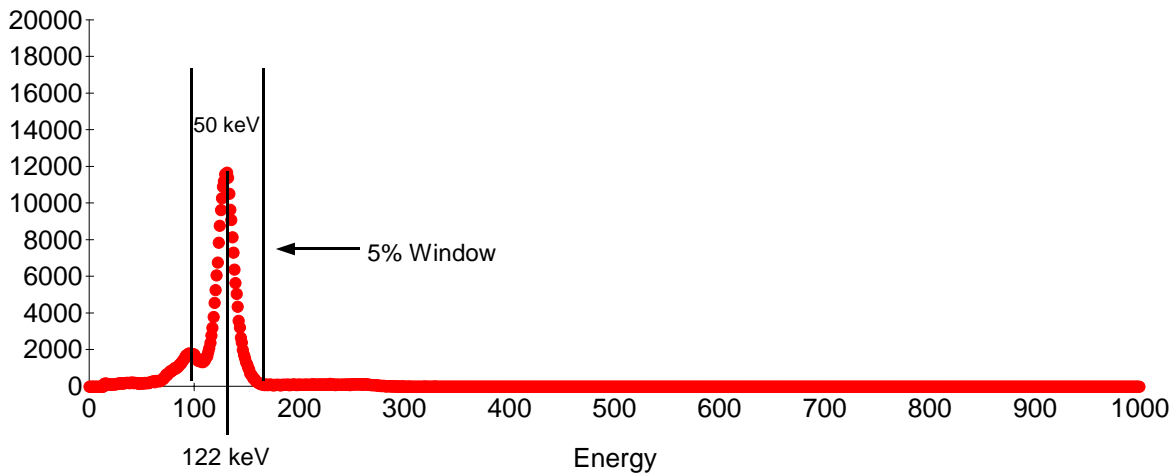

Using the ST450 and ST350 Combination.

The ST350 Radiation Counter provides a convenient counter/timer for use with the ST450. This instrument also offer interfacing to a PC or Macintosh computer for data storage and external baseline control. This feature allows the user to acquire a complete gamma spectrum of the sample being measured and aids in the selection of the correct window setting.

Connect the **ST350 IN** to the **GM INPUT** on the ST350.

Manual Mode

Turn on power to both instruments

Ensure the **EXT SCAN** button is not depressed and the high voltage on the ST350 is set to zero.

Select **TIME** and use the up/down buttons on the ST350 to select the required counting time.

Return the selector switch to the **COUNTS** position and preset the **COUNT** key. The ST350 will acquire data for the selected preset time and display the counts.

To use the **RATEMETER** mode, set the counting time to zero, select **RATEMETER** and press **COUNT**. The ST350 will now function as a digital ratemeter which is useful when calibrating the system.

More information on using the ST350 may be found in the instrument manual.

Computer Operation

Connect the serial cable from the ST350 to the PC or Macintosh and load the appropriate software.

Set the selector switch to the **REMOTE** position and turn on the power.

Run the ST350 software. A communication link will be established. Operation of the ST350 will now be from the computer.

Data will now be recorded as a sequence file that may be saved as a ASCII file or transferred through the clipboard for opening with a spreadsheet such as Excel.

Performing a Spectrum Sweep.

The high voltage supply in the ST350 may be used to control the baseline setting of the ST450. This feature allows a complete gamma-ray spectrum of the sample to be acquired which can be very useful for determining correct calibration and window settings. the system is organized so that a high voltage setting of 200 volts on the ST350 corresponds to a baseline of zero (min.) and 1200 volts corresponds to a baseline of 1000 (max.).

Using the Lablink software, set the ST350 high voltage to 200 volts.

Set the voltage step to 10 volts and turn on the **Ramp**.

Set **Runs** to 100. Set **Preset Time** to 10 sec.

Set **WINDOW** on the ST450 to 1%.

Select the **EXT SCAN** button.

Place the sample on the detector.

Start the ST350 counting.

The ST350 will now begin counting at zero baseline reference. At the completion of the 10 sec counting period the ST350 will record the data, increment the high voltage by 10 volts, decrement the run counter, reset the data and begin a new count. This process will continue until 100 measurements have been recorded to the maximum voltage value of 1200 volts on the ST350 corresponding to a baseline value of 1000.

At the end of the run the ST350 voltage will be restored to 200 volts and the data may be saved as a *.TSV file for exporting to a spreadsheet such as Excel for graphing.

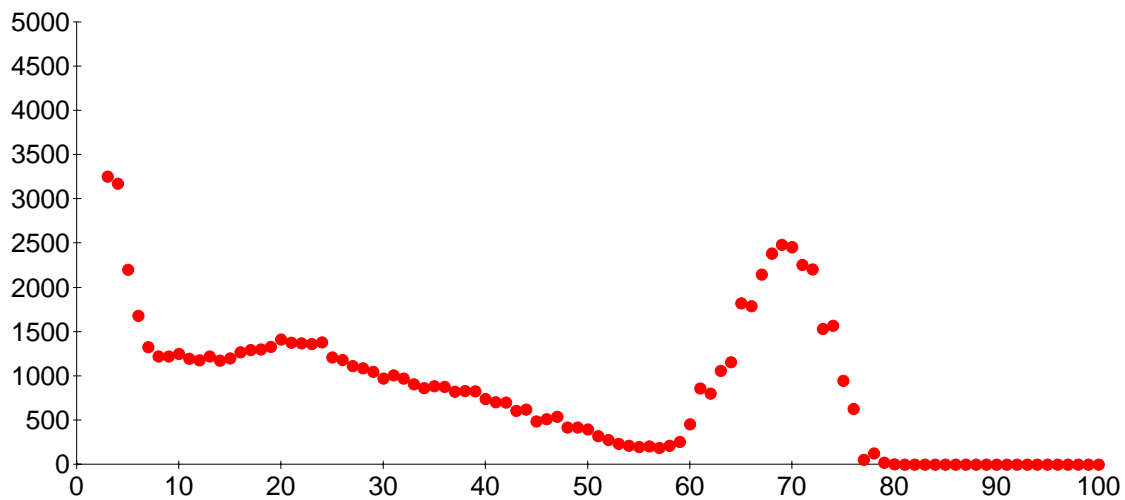

Typical Spectrum Sweep of Cs-137 Source.

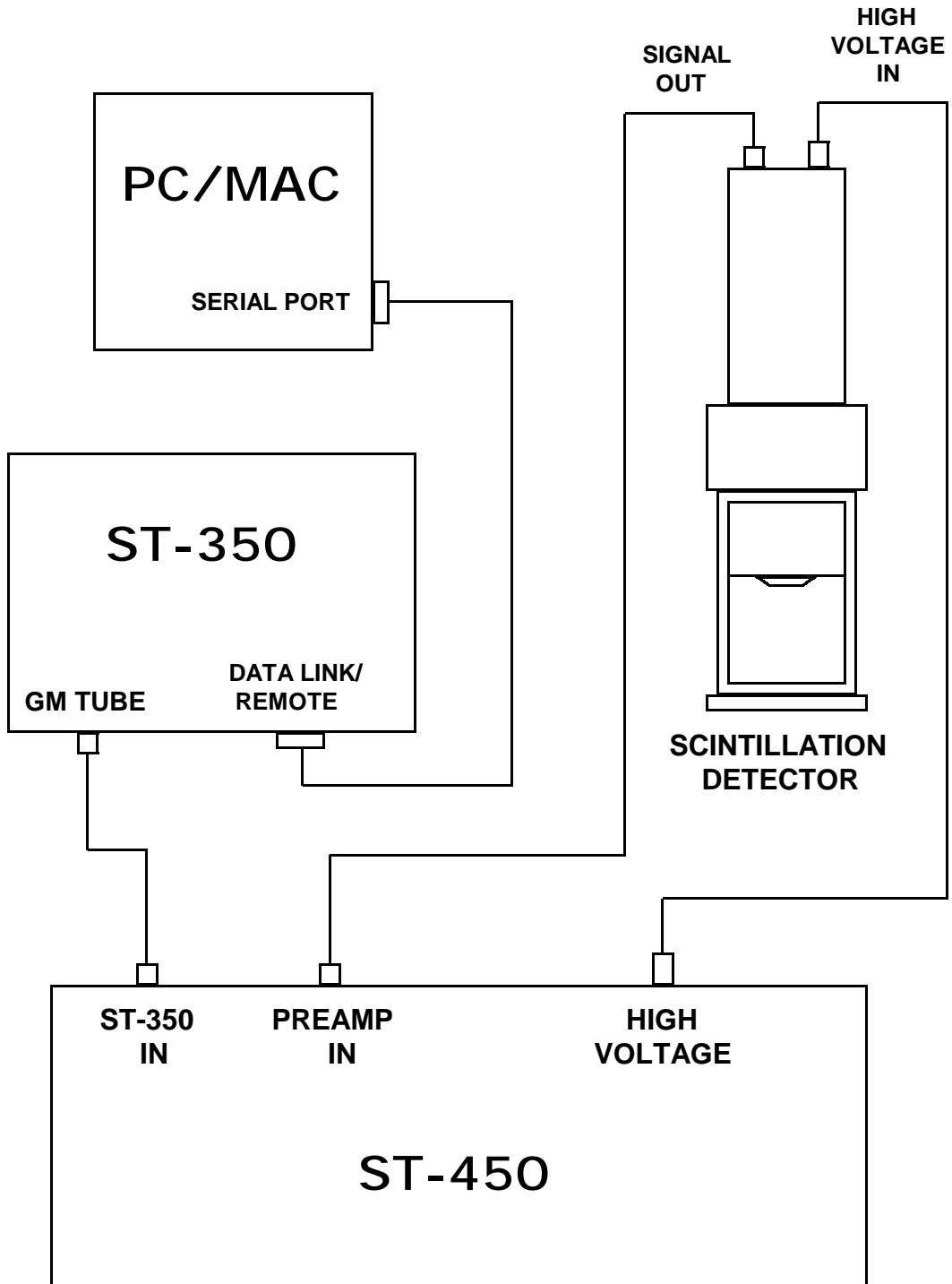

System Connection Diagram

Wipe Testing

Wipe tests are inherently low-level measurements and it is necessary to perform background subtraction on all samples to generate accurate activity data. Because the background reading is low, it is normally counted for a longer period to improve the statistics. The following steps illustrate a typical wipe testing procedure:

1. Set up the ST450 as described in the **Single Channel Analyzer** section for the energy peak of the source being tested.
2. Remove all radioactive material from the vicinity of the detector.
3. Set a preset time of 600 sec. and begin the counting.
4. When the unit completes the count, record the value and divide the reading by 10 to derive the background counts/min.
5. Position the sample into either the well of the detector or in the sample tray, depending on which detector is being used.
6. Set the preset time to 60 seconds and press START.
7. When the unit times-out record the number of counts.
8. Subtract the background counts/min. and record the net value. This is the counts/minute for the sample.

This concludes the ST450 Instruction Manual. If any problems are encountered or further information is needed, please contact Spectrum Techniques at (865) 482-9937, spectech@esper.com.

Manufactured by:

Spectrum Techniques, Inc.
106 Union Valley Road
Oak Ridge, TN 37830
USA
www.spectrumtechniques.com
Tel: (865) 482-9937
Fax: (865) 483-0473

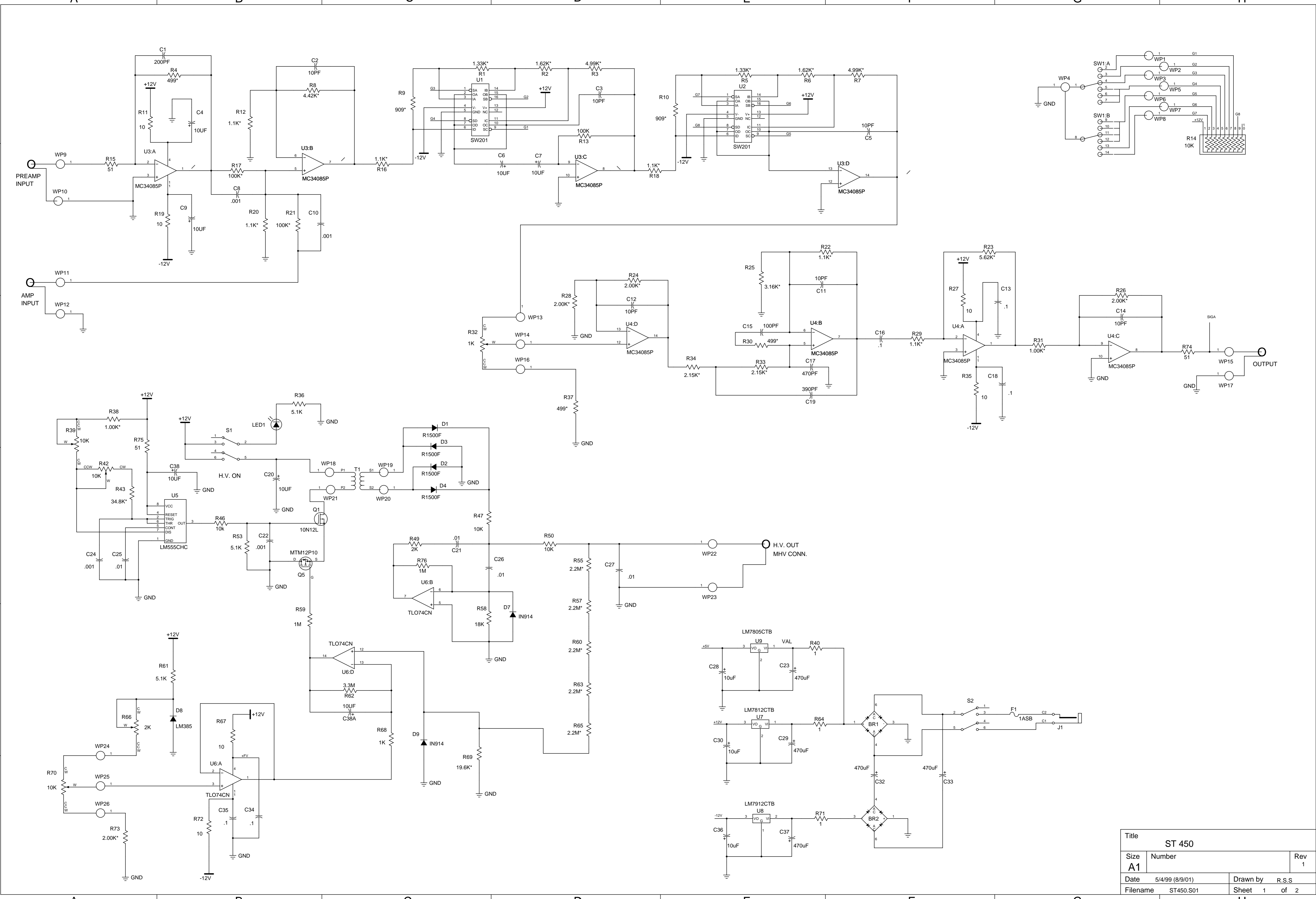

Title			ST 450		
Size	Number				Rev
A1					1
Date	5/4/99 (8/9/01)		Drawn by		R.S.S
Filename	ST450.S01		Sheet		1 of 2

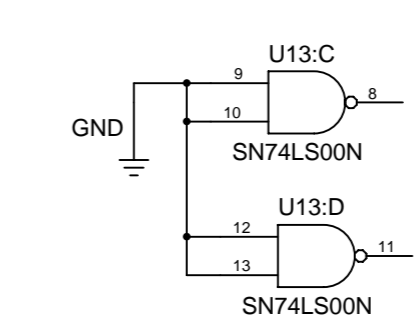
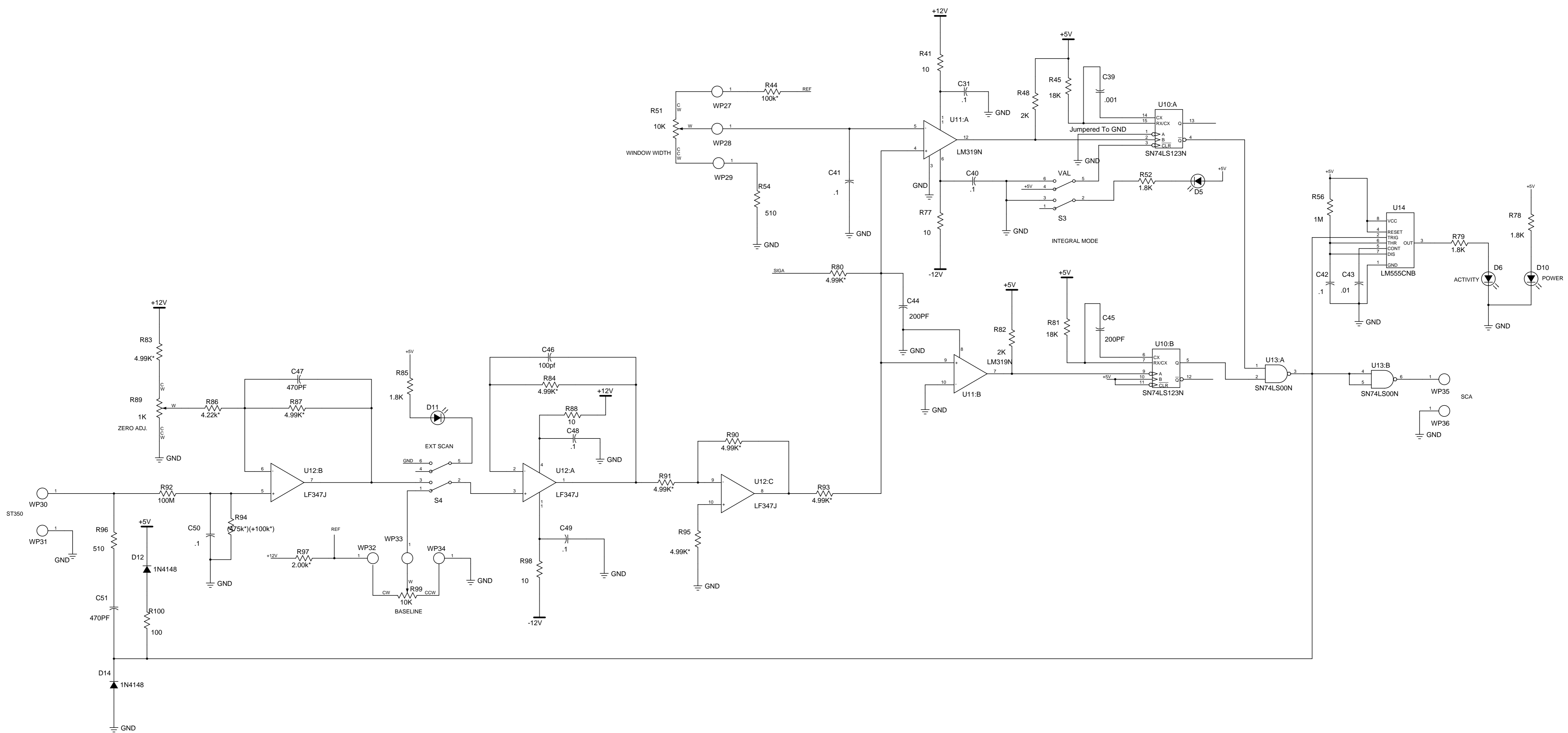

Title			ST 450 (SCA)		
Size	A1		Number		
Date	5/4/99 (8/8/01)		Drawn by	RSS	
Filename	ST420.S02		Sheet	2 of 2	
			Rev	1	