

PORTABLE Shop

E/DW

T.O. 11H4-7-3-201

41729

TECHNICAL MANUAL

OPERATION INSTRUCTIONS

MAINTENANCE INSTRUCTIONS

OVERALL INSTRUCTIONS  
WITH PARTS BREAKDOWN

RADIAC SET  
AN/PDR-27T

NSN 6665-01-120-5978

NUCLEAR RESEARCH CORPORATION  
125 Titus Avenue  
Warrington, Pennsylvania 18976

Contract F41608-81-D-0065

EACH TRANSMITTAL OF THIS DOCUMENT OUTSIDE THE DEPARTMENT  
OF DEFENSE MUST HAVE APPROVAL OF THE ISSUING SERVICE.

Distribution Statement: This publication is required for official use or  
for administrative or operational purposes only. Distribution is limited  
to U. S. Government agencies. Other requests for this document must be  
referred to San Antonio ALC/MMEDT, Kelly Air Force Base, Texas 78241.

PUBLISHED UNDER AUTHORITY OF THE SECRETARY OF THE AIR FORCE

1 OCTOBER 1982

# LIST OF EFFECTIVE PAGES

INSERT LATEST CHANGED PAGES; DISPOSE OF SUPERSEDED PAGES IN ACCORDANCE WITH APPLICABLE REGULATIONS.

- NOTE: 1. The portion of text affected by changes is indicated by a vertical line in the outer margins of the page. Changes to illustrations are indicated by miniature pointing hands. Changes to wiring diagrams are indicated by shaded areas.
2. Zero in the Change No. column indicates an original page.
3. An asterisk indicates pages changed, added, or deleted by the current change.

DATES OF ISSUE FOR ORIGINAL AND CHANGED PAGES ARE:

Original . . . . . 0 . . . . . 1 Oct 1982

TOTAL NUMBER OF PAGES IN THIS PUBLICATION IS 88 CONSISTING OF THE FOLLOWING:

Page No.	Change No.	Page No.	Change No.	Page No.	Change No.
Title . . . . .	0				
A . . . . .	0				
a . . . . .	0				
b Blank . . . . .	0				
i - iii . . . . .	0				
iv Blank . . . . .	0				
1-1 - 1-6 . . . . .	0				
2-1 . . . . .	0				
2-2 . . . . .	0				
3-1 - 3-3 . . . . .	0				
3-4 Blank . . . . .	0				
4-1 - 4-9 . . . . .	0				
4-10 Blank . . . . .	0				
5-1 . . . . .	0				
5-2 . . . . .	0				
6-1 - 6-3 . . . . .	0				
6-4 Blank . . . . .	0				
6-5 - 6-7 . . . . .	0				
6-8 Blank . . . . .	0				
6-9 - 6-30 . . . . .	0				
7-1 - 7-3 . . . . .	0				
7-4 Blank . . . . .	0				
7-5 - 7-6 . . . . .	0				
8-1 - 8-13 . . . . .	0				
8-14 Blank . . . . .	0				

Upon receipt of the second and subsequent changes to this technical order, personnel responsible for maintaining this publication in current status will ascertain that all previous changes have been received and incorporated. Action should be taken promptly if the publication is incomplete.

## W A R N I N G

## HIGH VOLTAGE

High voltage is used in the operation of this equipment. Severe shock may result if personnel fail to observe safety precautions. Learn the areas containing high voltage in each piece of equipment. Be careful not to contact high voltage connections when installing or working on this equipment. When servicing, ground points of high potential before touching them.

## TABLE OF CONTENTS

<u>Section</u>	<u>Paragraph</u>	<u>Page</u>
I	GENERAL INFORMATION.....	1-1
	1-1 Introduction.....	1-1
	1-2 General Description.....	1-1
	1-3 Description of Units.....	1-1
	a. Case CY-7779A/PDR-27.....	1-1
	b. Radiacmeter IM-238/PDR-27T.....	1-1
	c. Radiac Detector DT-613/PDR-27T.....	1-3
	d. Headset H-43B/U.....	1-3
	e. Carrying Strap P/N A6957.....	1-3
	f. Radioactive Test Sample TS101.....	1-3
	g. Arctic Battery Kit.....	1-3
	h. Spare Parts.....	1-3
	1-4 Reference Data.....	1-4
	1-5 Equipment Accessories and Documents Supplied.....	1-4
	1-6 Equipment and Publications Required But Not Supplied.....	1-4
	1-7 Field Changes and Factory Changes.....	1-4
II	SPECIAL TOOLS AND TEST EQUIPMENT.....	2-1
	2-1 Special Tools.....	2-1
	2-2 Special Test Equipment.....	2-1
	2-3 Radioactive Test Sample.....	2-1
III	INITIAL ISSUE AND RESHIPMENT.....	3-1
	3-1 Unpacking.....	3-1
	3-2 Operational Check.....	3-1
	3-3 Preparation for Storage or Shipment.....	3-1
IV	OPERATION.....	4-1
	4-1 General.....	4-1
	4-2 Controls and Indicators.....	4-1
	4-3 Preparation For Use.....	4-2
	4-4 Operational Check.....	4-2
	4-5 Operation with Arctic Battery Kit.....	4-6
	4-6 Radiation Detection and Measurement.....	4-8
	a. Measuring Gamma Radiation.....	4-8
	b. Detecting Beta Radiation.....	4-8

## TABLE OF CONTENTS (Continued)

<u>Section</u>	<u>Paragraph</u>	<u>Page</u>
V	INSPECTION AND OPERATIONAL CHECK REQUIREMENTS.....	5-1
	5-1 Inspection and Operational Check Frequencies.....	5-1
VI	MAINTENANCE INSTRUCTIONS.....	6-1
	6-1 Introduction.....	6-1
	6-2 Scheduled Maintenance Action Index.....	6-1
	6-3 Theory of Operation.....	6-1
	6-4 Functional Sections.....	6-2
	a. Power Supply.....	6-2
	b. Radiation Detectors.....	6-5
	c. Computer Circuit.....	6-6
	6-5 Troubleshooting, General.....	6-10
	a. Symptom Recognition.....	6-10
	b. Symptom Elaboration.....	6-10
	c. Listing Probable Faulty Function.....	6-12
	d. Use of Test Points.....	6-12
	6-6 Troubleshooting Index.....	6-12
	6-7 Troubleshooting Procedures.....	6-12
	a. Preliminary Check, General.....	6-12
	b. Power Supply and Computer Circuit.....	6-13
	6-8 Repair.....	6-15
	6-9 Repair Procedures.....	6-15
	a. Tube Replacement.....	6-15
	b. Printed Circuit Board Removal & Replacement.....	6-17
	c. Meter Replacement.....	6-25
	d. Meter Illumination Switch Replacement.....	6-25
	e. Range Switch Replacement.....	6-27
	f. Meter Lamp Replacement.....	6-27
	6-10 Adjustment and Calibration.....	6-28
	a. General.....	6-28
	b. Equipment Required For Calibration.....	6-28
	c. Pre-alignment.....	6-28
	d. Source Calibration.....	6-29
VII	DIAGRAMS.....	7-1
	7-1 Introduction.....	7-1
	a. Overall Schematic.....	7-1
	b. Chassis and Switch Wiring.....	7-1
	c. Parts Location.....	7-1
	d. Test Point Waveforms.....	7-1
VIII	PARTS LIST.....	8-1
	8-1 Introduction.....	8-1
	8-2 List of Manufacturers.....	8-1

## LIST OF TABLES

<u>Table</u>	<u>Title</u>	<u>Page</u>
1-1	Reference Data.....	1-5
1-2	Equipment, Accessories and Documents Supplied.....	1-6
2-1	Special Test Equipment.....	2-2
5-1	Frequency of Inspection and Operational Check.....	5-2
6-1	Scheduled Maintenance Action Index.....	6-1
6-2	Maintenance Turn-On Procedure.....	6-11
6-3	Troubleshooting Index, Radiacmeter IM-238/PDR-27....	6-12
6-4	Radiacmeter IM-238/A/PDR-27T System Troubleshooting Chart.....	6-19
6-5	Power Supply Circuit Trouble Analysis.....	6-21
6-6	Computer Circuit Trouble Analysis.....	6-22
7-1	Wiring Run List.....	7-1
8-1	Parts List.....	8-2
8-2	List of Manufacturers.....	8-13

## LIST OF FIGURES

<u>Figure</u>	<u>Title</u>	<u>Page</u>
1-1	Radiac Set AN/PDR-27T, Relationship of Units.....	1-2
3-1	Radiac Set In Case.....	3-2
4-1	Radiacmeter IM-238A/PDR-27T, Top Panel Controls.....	4-1
4-2	Battery Installation.....	4-3
4-3	Test Sample.....	4-4
4-4	Position 500, 50 and 5 Checks.....	4-5
4-5	Position 0.5 Check.....	4-5
4-6	Probe Position in Storage.....	4-6
4-7	Arctic Battery Kit.....	4-7
6-1	Functional Block Diagram.....	6-2
6-2	Power Supply Schematic.....	6-3
6-3	Radiation Detectors.....	6-5
6-4	Computer Circuit.....	6-7
6-5	Monostable Multivibrator.....	6-9
6-6	Radiacmeter IM-238A, PDR-27T, Right Side.....	6-14
6-7	Radiac Probe DT-613A, PDR-27T Disassembled.....	6-16
6-8	Rear View, Top Panel.....	6-18
6-9	Radiacmeter IM-238A/PDR-27T, Left Side.....	6-26
7-1	Overall Schematic.....	7-3
7-2	Parts Location, Printed Wiring Board Assembly 1A1 ..	7-5
7-3	Test Point Waveforms.....	7-6

## SECTION I

## GENERAL INFORMATION

1-1. INTRODUCTION. This technical manual is in effect upon receipt. Extracts from this publication may be made to facilitate the preparation of other Department of Defense Publications. This manual covers only the AN/PDR-27T, NSN 6665-01-120-5978 manufactured under contract F41608-81-D-0065. It does not cover any of the earlier AN/PDR-27 sets other than the T series.

1-2. GENERAL DESCRIPTION. Radiac Set AN/PDR-27T is a portable, battery operated radiation detector and indicator (Figure 1-1) capable of detecting and measuring up to 500 milliroentgens of gamma radiation and can detect the presence of beta radiation. Radiacmeter IM-238/PDR-27T is the main unit of the radiac set. The radiacmeter is equipped with carrying handle and detachable shoulder harness. Radiac Detector DT-613/PDR-27T, attached to the radiacmeter by a detachable coiled cable, is a two-compartment probe which is stowed in the mounting clip on the radiacmeter case. The radiacmeter housing encloses an electronic chassis, an indicating meter and dry-cell batteries. Case CY-7779A/PDR-27T is a lightweight carrying case which houses the Radiacmeter IM-PDR-27T, Headset H-43 B/U, Harness P/N B1031, spare tubes, Check Source TS101 and Arctic Battery Kit BK101.

1-3. DESCRIPTION OF UNITS. Radiac Set AN/PDR-27T consists of the units listed in Table 1-1.

a. Case CY-7779A/PDR-27T. The carrying case houses all the other units of the radiac set (Figure 1-1). It is splashproof and is equipped with a carrying handle. The case is rectangular shaped and can readily be decontaminated. Compartments to carry a spare set of batteries as well as all the other components are provided in the case.

b. Radiacmeter IM-238A/PDR-27T. The radiacmeter includes a housing made of two aluminum castings with a gasketed seam. The top casting or panel supports all of the electronic circuitry and includes a separate sealed battery compartment. The bottom casting acts as a cover which encloses the electronic circuitry and the battery compartment.

Mounted on the panel is an indicating meter, a range switch, a push-button switch, headset jack and connector for external arctic battery pack. Mounted to the underside of the panel (Figure 6-9) is the printed circuit board containing the electronic circuitry.

The indicating meter is placed behind a sealed plastic window for waterproofing. It has 5 movable scales which are mechanically coupled to the range switch so that the scale corresponding to the switch position is presented.

The push-button switch controls the meter lamp.

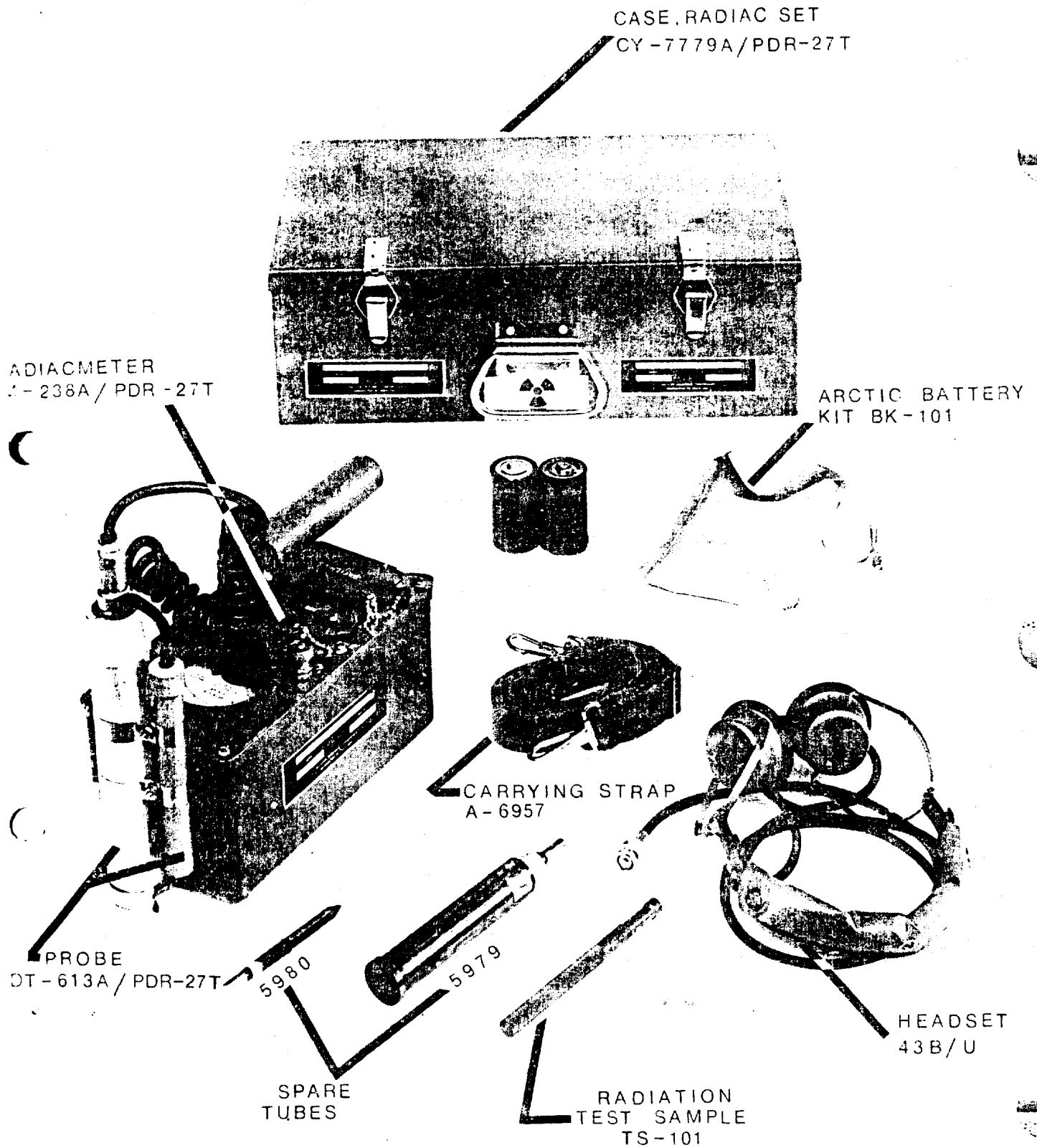

FIGURE 1-1. RADIAC SET AN/PDR-27T, RELATIONSHIP OF UNITS



c. Radiac Detector DT-613A/PDR-27T. The radiac detector is a probe consisting of a type JAN-5979 Geiger Mueller tube and a type JAN-5980 Geiger Mueller tube, each enclosed in its own cylindrical metal housing (Figure 1-1). The two housings are clamped together into one unit. A movable metal shield normally covers the mica window of the larger tube. When the shield is over the window, beta radiation is excluded from the tube. The shield can be swung aside when beta-plus gamma radiation readings are desired.

#### CAUTION

Since the #5979 GM tube mica window is only 0.0005 inches thick, it is extremely fragile. Do not touch the window under any circumstances, as damage to the tube will result. Do not rely upon the guard ring to protect the mica window. The guard ring openings are large enough so that sharp objects may pierce the window.

Electrical connections for both GM tubes are made at the ends of the housing where the shielded cables pass through waterproof packing glands to the tube electrodes. The probe cable is flexible and kink-proof.

d. Headset H-43B/U. The headset provides the operator with aural indications of radiation intensity when plugged into the jack on the panel (Figure 4-2). The headset is designed to fit inside a battle helmet.

e. Carrying Strap P/N A6957. The shoulder harness, an adjustable strap made of non-absorbent plastic, is used for carrying the radiacmeter during operation. Clip fasteners on each end of the strap snap into holes in small projections on the radiacmeter panel (Figure 4-1).

f. Radioactive Test Sample TS101. The Radioactive Test Sample is provided to qualitatively test the overall functioning of the Radiacmeter. It consists of an aluminum rod, enclosing at one end, a Cs-137 Source of less than 10 microcuries. When not in use, the test sample is stored in the carrying case along with the spare GM tubes.

g. Arctic Battery Kit. The arctic battery kit consists of a metal battery holder, a cable and a connector to connect external batteries to the radiacmeter. This is carried in a vinyl pouch and stored in the carrying case.

h. Spare Parts. The field spares, consisting of one each of the GM tubes are carried in the spare parts compartment (Figure 1-1) of the carrying case.

1-4. REFERENCE DATA. The reference data for the radiac set is listed in Table 1-1.

1-5. EQUIPMENT ACCESSORIES AND DOCUMENTS SUPPLIED. Table 1-2 lists the dimensions and weights of all the components of Radiac Set AN/PDR-27T.

1-6. EQUIPMENT AND PUBLICATIONS REQUIRED BUT NOT SUPPLIED. None.

1-7. FIELD CHANGES AND FACTORY CHANGES. None.

Table 1-1. REFERENCE DATA

ITEM	DESCRIPTION
Nameplate Data	
Radiac Set	AN/PDR-27T RADIAC SET  SUPPLY: 3 VDC Consists of accessories and the following: 1 RADIACMETER IM-238A/PDR-27T U.S. AIR FORCE
Radiacmeter	RADIACMETER IM-238A/PDR-27T  SUPPLY: 3 VDC A unit of Radiac Set AN/PDR-27T U.S. AIR FORCE
Probe	PROBE, Radiac DT-613A/PDR-27T A unit of Radiac Set AN/PDR-27T U.S. AIR FORCE
Case	CASE, Radiac Set CY-7779A A unit of Radiac Set AN/PDR-27T U.S. AIR FORCE
Miscellaneous Components	HEADSET, Electrical, H-43B/U ARCTIC BATTERY KIT P/N BK-101 CARRYING STRAP, P/N B1031
Dimensions and Weights	See Table 1-2.
Operating Temperature	-40° to +60° C
Operating Altitude	Any altitude up to 50,000 ft.
Power Requirements	2 each internal BA-30 1-½ volt "D" Cell Batteries
Accuracy	± 20% from 10% full scale on each range throughout entire operating temperature range.
Range Indication	Meter type indication provided on four ranges: 0-0.5, 0-5, 0-50, 0-500 mR/hr.
Energy Range	Measures gamma radiation from 80 kev to 2 mev. Detects beta radiation on 0-0.5 and 0-5 mR/hr ranges.
Battery Check	Meter indication of battery condition provided.
Meter Light	Momentary switched meter light provided.

Table 1 EQUIPMENT, ACCESSORIES AND DOCUMENTS SUPPLIED

QTY.	NAME	NOMENCLATURE DESIGNATION	OVERALL DIMENSIONS (Inches)			WEIGHT (lbs)	VOLUME	
			Height	Width	Depth		(cu.in.)	(cu.ft.)
1	Radiacmeter (with batteries)	IM-238A/PDR-27T	7	4.5	8.5	4.5	268	0.08
1	Case, Radiac Set	CY-7779A/PDR-27T	5½	15	9	8.5	743	.43
1	Probe, Radiac	DT-613A/PDR-27T	1½	9	2½	1.1	11.4	
1	Harness	A6957	54	1	1/16	0.30	0.003	
1	Headset	H-43B/U	6.12	7	2.12	0.05	0.087	
1	Tube, Electron	JAN 5979	1 dia.		5	0.17	3.95	
1	Tube, Electron Spare	JAN 5980	.37 dia.		4	0.02	0.44	
2	Technical Manual (Note 1)	T.O. 11H4-7-3-201	10-3/4	8½				
1	Arctic Battery Kit (Note 2)	NRC P/N BK-101	6	3½	2½	0.5	52.5	
1	Check Source	TS101	5 lg.	3/8 dia				

NOTES: 1) Manual size is 8½ x 10-3/4 and is packaged separately.  
 2) Supplied with the units on Contract F41608-81-D-0065 only.

## SECTION II

## SPECIAL TOOLS AND TEST EQUIPMENT

2-1. SPECIAL TOOLS. There are no special tools required to operate, maintain or disassemble the AN/PDR-27T Radiac Set. A "pencil" soldering iron will be useful as will be solder wick for component removal. Care should be taken when soldering to apply minimum heat and to avoid burning nearby leads and components. A heat sink (such as long nose pliers, alligator clips, etc.) is required when soldering semiconductors. Disturb lead dressing as little as possible. Take care to keep foreign particles (dust, smoke, metal filings, solder, etc.) out of the radiac-meter during repair.

## WARNING

Avoid breathing fumes generated by soldering for prolonged periods. Use adequate ventilation. High protection is required. Use extreme precaution to avoid being burned.

2-2. SPECIAL TEST EQUIPMENT. Although any normally equipped repair and calibration depot would have sufficient electronic instrumentation, particular models or styles would facilitate electronic troubleshooting and repair. Table 2-1 lists a grouping of some of the preferred test equipment. Only one of each category is needed; i.e., one scope with two probes, one counter, one electrostatic voltmeter or one high impedance precision voltmeter, and one low voltage voltmeter. The stock listed item shown in the respective block is the AF equivalent test equipment.

2-3. RADIOACTIVE TEST SAMPLE. A low level radioactive test source (TS101) provided with the AN/PDR-27T series radiac sets or some other source of radiation may be used for checking operability on all ranges. Known sources of gamma radiation such as that derived from the AN/UDM-1 or 1 A calibrators are required for equipment calibration.

MODEL NO.	NOMENCLATURE & MFG.	NATIONAL STOCK NO.	USE OR APPLICATION
465M/USM425()	Tektronix Oscilloscope	6625-01-032-6914	Test Point Waveshapes
P6007	Tektronix 100X Probe	6625-00-163-1444	Test Point Waveshapes
P1061D-M110	Tektronix 1X Probe	6625-00-163-1448	Test Point Waveshapes
101	Systron Donner Pulse Gen.	6625-00-454-0708	Electronic Calibration
5340	Hewlett Packard Counter	6625-00-098-8946	Electronic Calibration
MD6057	Systron Donner Counter	6625-00-010-6796	Electronic Calibration
ESD, 0-1.5 KV	Sensitive Research ESVM	NSL	H. V. Measurements
8100A	J. Fluke Diff. VM	6625-01-010-4234	L. V. Measurements
8100A	80K-40KV Probe	6625-01-010-4700	H. V. Measurements
269	Simpson V.O.M.	NSL	L. V. Measurements
AN/UDM-1*	Radiac Calibrator	6665-00-669-0077	Cobalt 60 Calibration Source
AN/UDM-1A*	Radiac Calibrator	6665-00-556-8825	Cesium 137 Calibration Source
D0062	Radiac Calibrator	6665-00-819-6606	Cesium Calibration Source (100 mCi)

NSL - Not Stock Listed; use stock listed item when available.

\* Optional

## SECTION III

## INITIAL ISSUE AND RESHIPMENT

3-1. UNPACKING. When unpacking the Radiac Set, shown in its case in Figure 3-1, perform the following steps:

NOTE

If the Radiac Set is shipped in a corrugated carton, complete only Steps 4 thru 7.

- STEP 1. Cut the two metal bands from the wooden shipping crate.
  - STEP 2. Pull out the nails securing the top cover and remove the cover.
  - STEP 3. Lift out the inner package.
  - STEP 4. Remove the outer corrugated carton.
  - STEP 5. Remove the foil bag and inner corrugated carton.
  - STEP 6. Remove the Radiac Set.
  - STEP 7. Open the carrying case and remove corrugated filler and wadding.
- 3-2. OPERATIONAL CHECK. Perform an operational check as outlined in Section IV.
- 3-3. PREPARATION FOR STORAGE OR SHIPMENT.

a. If instrument is placed in long-term storage or is being shipped, ensure the following:

- STEP 1. The Radiacmeter is turned off and all batteries are removed including arctic kit batteries if applicable.
- STEP 2. Carrying harness, arctic battery pack, headset and cord are properly stored in case.
- STEP 3. Radiacmeter is properly stored in case.
- STEP 4. Carrying case is closed and secured.

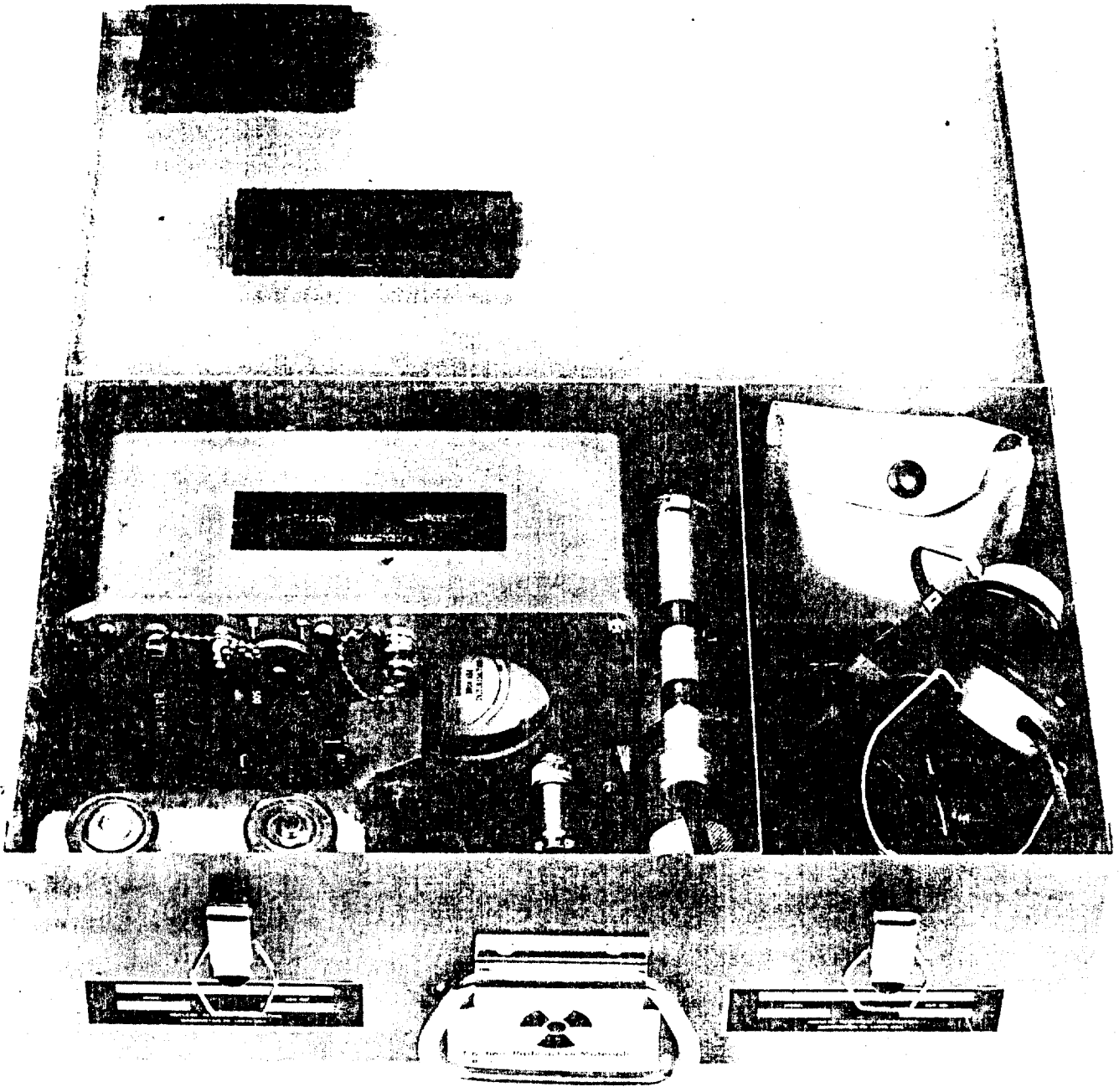

FIGURE 3-1. RADIAC SET IN CASE



b. If instrument is placed in short-term storage (without batteries installed); batteries will be placed in plastic bag and will be taped to the outside of the carrying case or stored inside the carrying case. Batteries may be stored under refrigeration and are not required to be placed in plastic bags while being stored in this manner.

NOTE

Batteries maintained under refrigeration must be allowed a warm-up period as specified in T.O. 00-25-213 before use in any instrument.

## SECTION IV

## OPERATION

4-1. GENERAL. This section contains information on operator-related components on the AN/PDR-27T, Preparation for Use, Operational Check and Beta/Gamma Monitoring Procedures.

4-2. CONTROLS AND INDICATORS. Figure 4-1 shows the operating controls. A single six position selector switch turns the unit on, provides for battery (BATT) check and selects the 500 mR/hr, 50 mR/hr, 5 mR/hr or .5 mR/hr ranges.

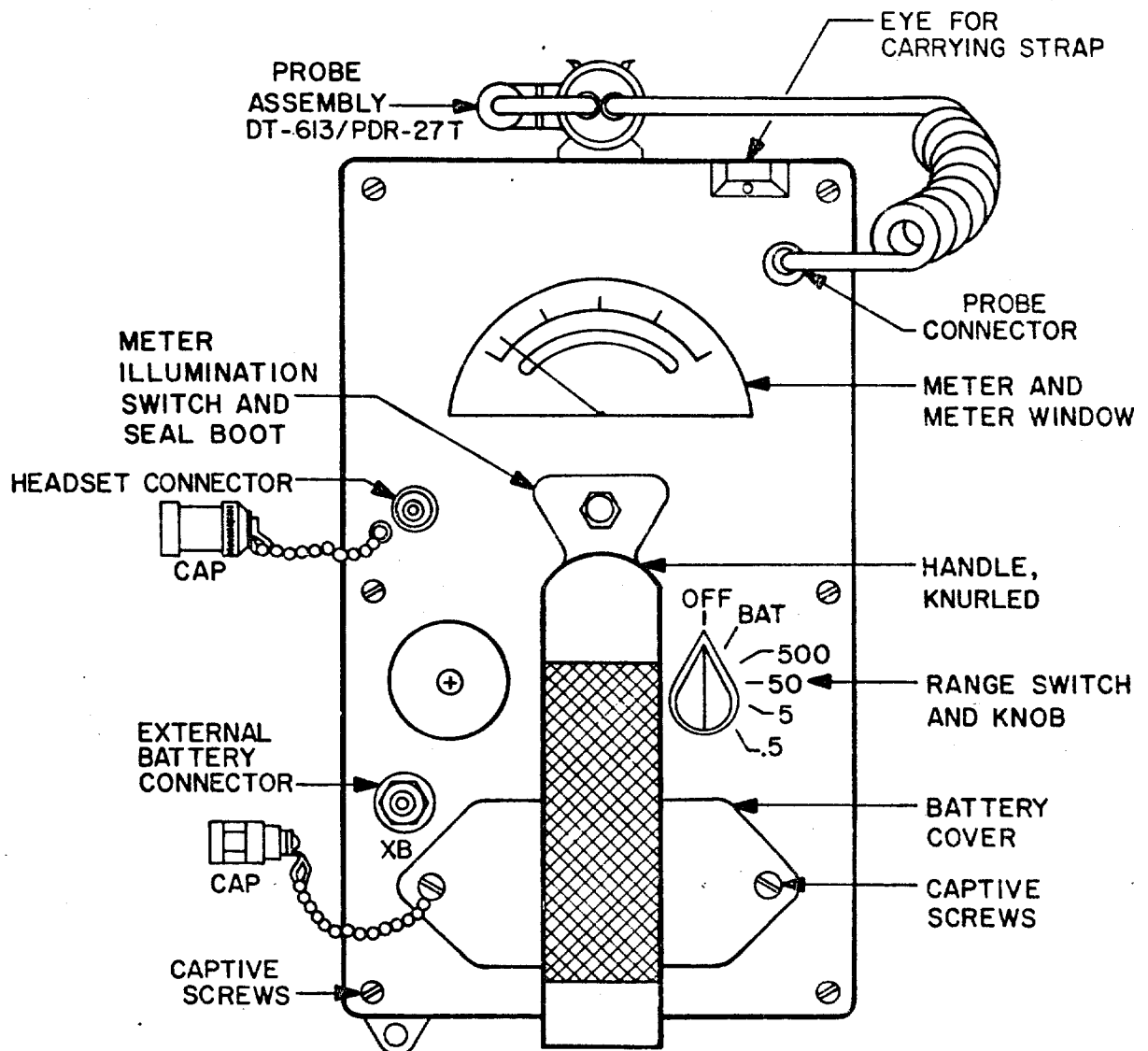

FIGURE 4-1. RADIACMETER IM-238A/PDR-27T, TOP PANEL CONTROLS

4-3. PREPARATION FOR USE.

STEP 1. Open carrying case.

STEP 2. Remove Radiacmeter from case.

STEP 3. Loosen battery cover screws, remove battery cover and insert batteries (BA-30, 1½ volt "D" Cell). Observe polarity markings on the top of the front panel under the battery cover (See Figure 4-2). Replace cover and tighten screws. (For use of Arctic Battery Kit, see Paragraph 4-5).

STEP 4. The Radiacmeter may be carried using the shoulder harness. If used, adjust the take-up buckle for the most comfortable sling length.

STEP 5. Connect the Headset to the Headset Jack on the Radiacmeter panel.

4-4. OPERATIONAL CHECK.

a. When the Radiac Set is certified by a calibration facility (PMEL), the check source reading is recorded and placed on the AFTO Form 140 in the carrying case and on the AFTO Form 108 label affixed to the instrument. If one or the other of forms are missing or illegible, the remaining form may be used for the operational check. If both these forms are missing, the instrument will be returned to the calibration facility.

b. Operational checks must be performed at intervals established in Table 5-1 and prior to use. The purpose of the check is to determine the functional operation of the Radiac Set. If readings are not within the ranges specified in Steps 6 thru 9, the instrument will be turned in to the PME Laboratory for further maintenance. Battery condition may cause a slight difference in meter readings and will be checked for serviceability prior to performing any other maintenance on the set.

NOTE

The test sample provided with the various Radiac Sets may vary slightly in radiation intensity. Always use the same test sample as utilized in the initial check.

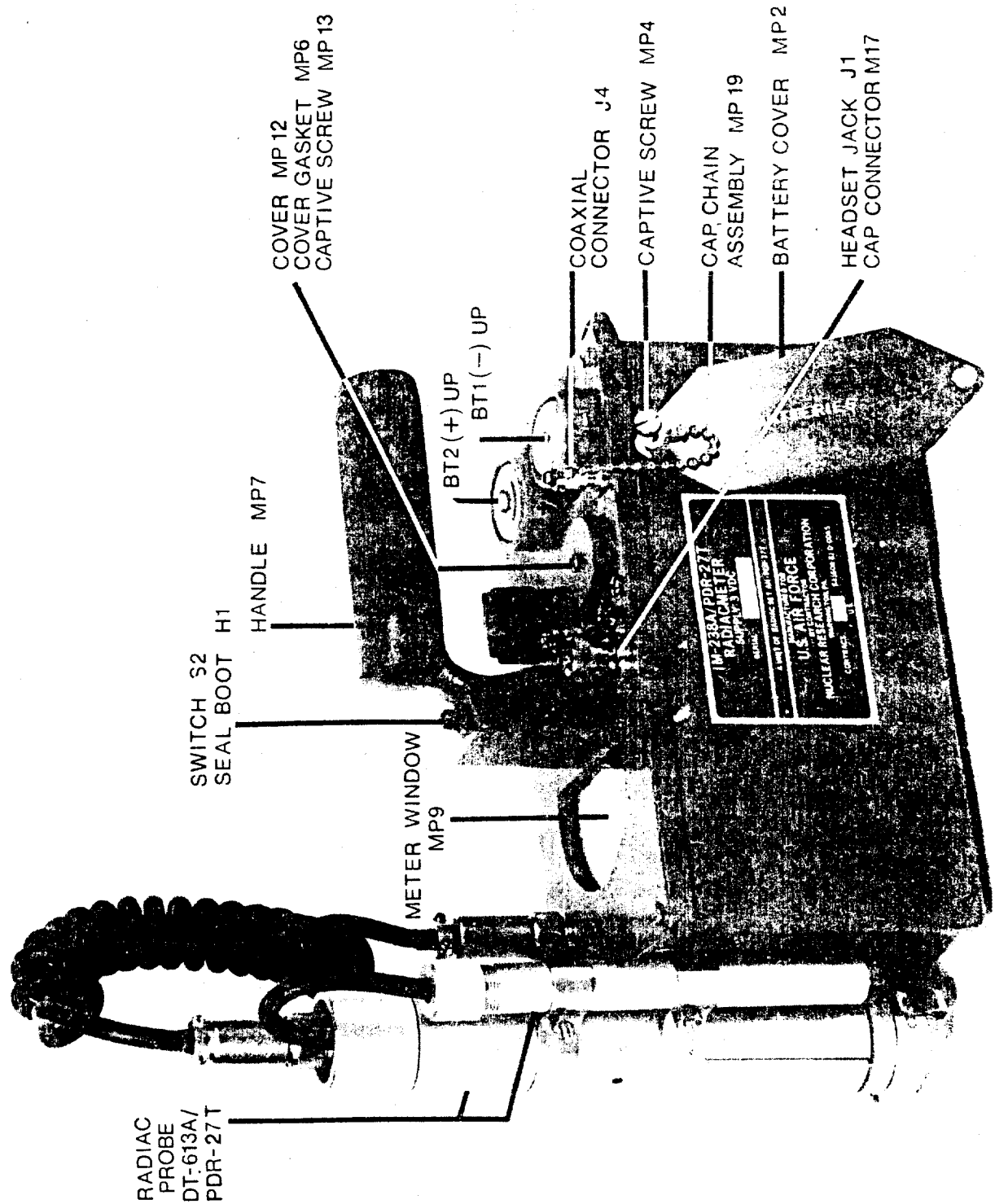

RADIAC  
PROBE  
DT-613A/  
PDR-27T

SWITCH S2  
SEAL BOOT H1

HANDLE MP7

METER WINDOW  
MP9

COVER MP12  
COVER GASKET MP6  
CAPTIVE SCREW MP13

BT2 (+) UP  
BT1 (-) UP

COAXIAL  
CONNECTOR J4

CAPTIVE SCREW MP4

CAP.CHAIN  
ASSEMBLY MP19

BATTERY COVER MP2

HEADSET JACK J1  
CAP CONNECTOR M17

IM-238A/PDR-27T  
RADIAC METER  
A UNIT OF RADIAC METER FOR  
THE U.S. AIR FORCE  
NUCLEAR RESEARCH CORPORATION  
CONTRACT NO. 33  
PART NO. 31

FIGURE 4-2. BATTERY INSTALLATION

STEP 1. Remove the Radiacmeter from carrying case.

CAUTION

If the power switch is found to have been left on from the previous operational check, the batteries may be deteriorating and corrosion developing. The battery compartment will be visually inspected immediately.

STEP 2. Turn the range switch to BATT position to check condition of batteries. The meter should read within the area marked "BATTERY". If not, replace with fresh batteries and repeat this step.

STEP 3. Turn the range switch to 500 position, the meter reading should be zero.

STEP 4. Install earphones to insure complete audio circuit is functioning properly.

WARNING

Steps 5 thru 10 involve handling of the radioactive test sample containing Cesium-137 radioactive source mounted at one end of an aluminum rod (see Figure 4-3). Hold test sample by the knurled end of the aluminum rod and store with the radioactive end in the styrofoam holder located in the instrument case.

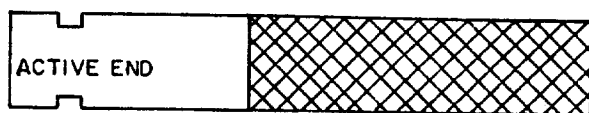

FIGURE 4-3. TEST SAMPLE

STEP 5. Remove radioactive test sample from the carrying case.

NOTE

A check source alignment dot is located on the large cylinder of the probe assembly to show alignment of the test sample for 500, 50 and 5 position operational checks.

STEP 6. Place the active end of the test sample perpendicular against the smaller cylinder of the Probe Assy. as shown in Figure 4-4. The meter should read between 10 and 30 mR/hr.

STEP 7. Turn the range switch to the 50 position. Hold the test sample as shown in Figure 4-4. The meter should read between 10 and 20 mR/hr.

STEP 8. Turn the range switch to the 5 position. Hold the test sample as shown in Figure 4-4, above. The meter should read between 1 and 2 mR/hr.

STEP 9. Turn the range switch to the .5 position. Place the test sample parallel with the small cylinder on the side directly opposite the larger cylinder with the active end even with the top of the retainer nut, as shown in Figure 4-5. The meter should read between .25 and .4.

CHECK SOURCE  
ALIGNMENT DOT

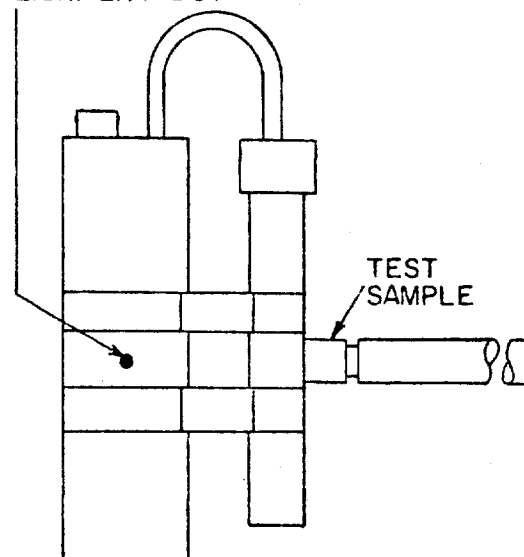

FIGURE 4-4. POSITION 500,  
50 and 5 CHECKS.

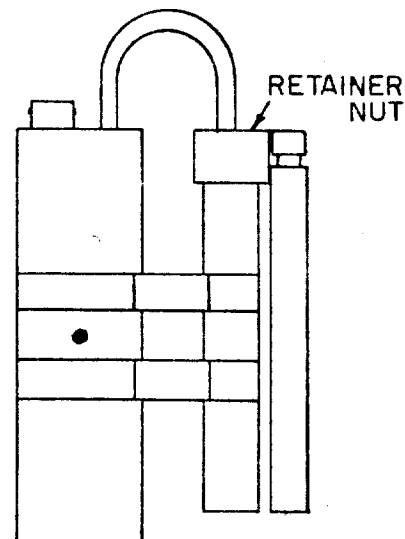

FIGURE 4-5. POSITION .5  
CHECK.

STEP 10. Replace the test sample in the carrying case.

STEP 11. Turn the range switch to OFF position.

STEP 12. Annotate the above readings on AFTO Form 140 for the Radiac Set.

CAUTION

To avoid probe damage when placing instrument in carrying case, ensure probe assembly is securely clipped to instrument and that the small cylinder on probe is positioned to the right or left of clip as shown in Figure 4-6.

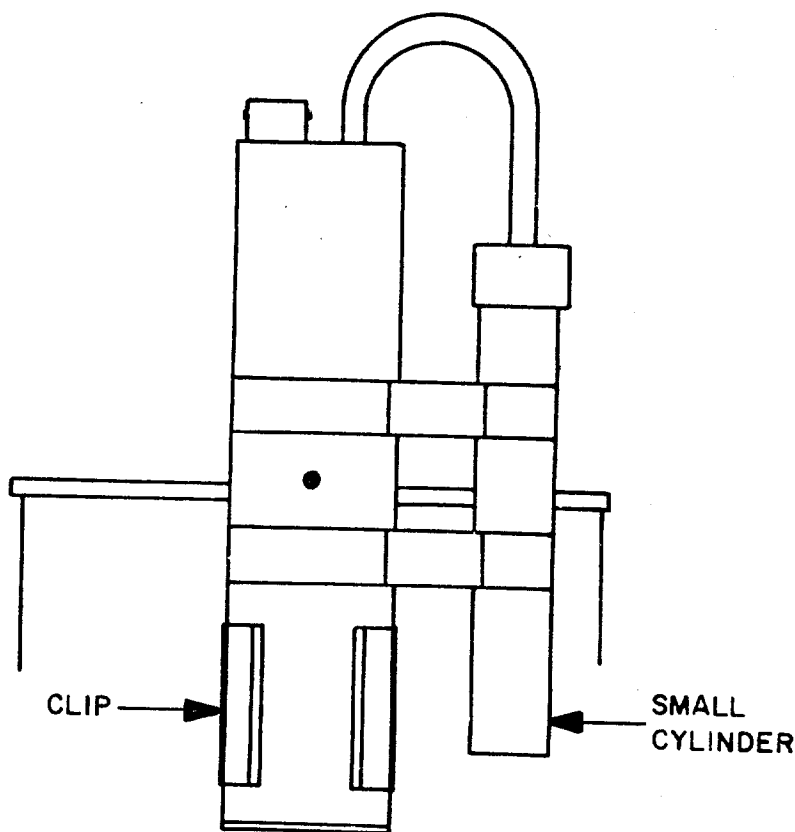

FIGURE 4-6. PROBE POSITION IN STORAGE.

4-5. OPERATION WITH ARCTIC BATTERY KIT. The Arctic Battery Kit is required to be installed when the instrument is operated in temperatures below 21° F.

STEP 1. Remove Arctic Battery Kit from pouch (See Figure 4-7).

STEP 2. Ensure batteries are removed from instrument before installing Arctic Battery Pack.

- STEP 3. Mate and lock Arctic Battery Plug to the socket marked XB on the Radiacmeter panel.
- STEP 4. Install batteries in Arctic Kit Cradle. Observe indicated polarity.
- STEP 5. Place battery cradle back into pouch and place pouch into pocket or suitable warm place for cold weather operation.

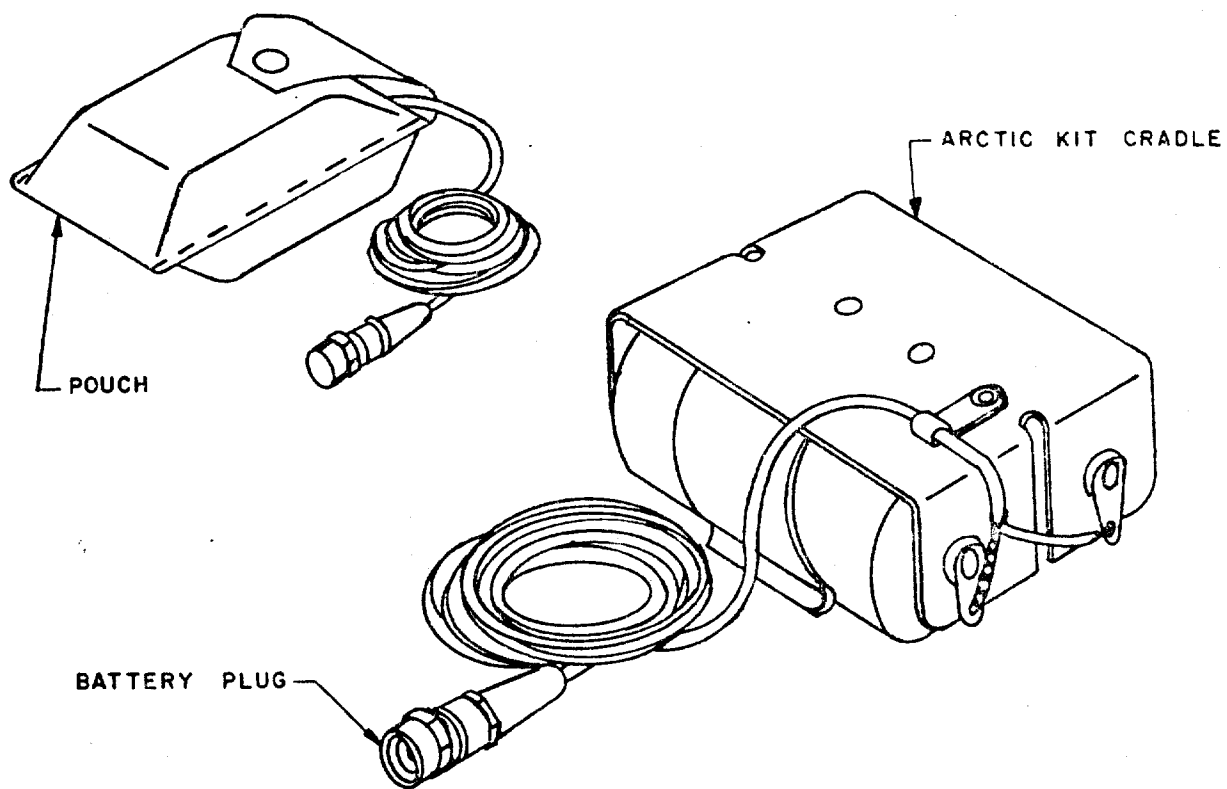

FIGURE 4-7. ARCTIC BATTERY KIT.



#### 4-6. RADIATION DETECTION AND MEASUREMENT.

##### a. Measuring Gamma Radiation.

STEP 1. Begin monitoring with the range switch on the 500 position. Turn the range switch to a lower (more sensitive) range whenever the meter reading is less than 10% of scale. Turn to a higher (less sensitive) range if the meter needle approaches the high end of the scale.

##### NOTE

If the Radiac Set is used in a dimly lit area, press the meter illumination switch to illuminate the meter face.

STEP 2. Listen for clicks in the headset and observe the meter reading while approaching the radioactive object or area. The meter reading and frequency of clicks in the headset are proportional to the radiation intensity.

STEP 3. To locate a radioactive object or the center of a radioactive area, move the radiacmeter in the direction that produces an increase in the meter reading or in the frequency of clicks in the headset. Continue moving in this direction until the point of maximum radiation intensity is found.

STEP 4. If an object or area to be investigated is relatively inaccessible, remove the probe from its clip mounting, set the range switch on the .5 or 5 position and pass the probe slowly back and forth over the area.

STEP 5. When the radiation from an object or area is extremely weak, bring the detector probe within 1 to 5 inches of the object to obtain the largest possible indication on the meter or headset because radiation intensity decreases with distance.

##### b. Detecting Beta Radiation.

STEP 1. To observe combined Beta and Gamma radiation, turn the range switch to the .5 or 5 position.

STEP 2. Remove the probe from clip mounting and swing open the Beta shield on the large cylinder of the probe assembly.

STEP 3. Bring the detector probe within 1 to 5 inches of the object. Point the exposed end of the probe at the object and move it slowly back and forth.

STEP 4. When a reading is obtained, close the Beta shield on the large cylinder of the probe assembly and remonitor area or object. If reading is absent or less than original reading, Beta radiation has been confirmed.

SECTION V

INSPECTION AND OPERATIONAL CHECK REQUIREMENTS

5-1. INSPECTION AND OPERATIONAL CHECK FREQUENCIES. Instruments stored with or without batteries installed will be inspected and operationally checked in accordance with Table 5-1.

WHAT TO CHECK	WHEN TO CHECK	HOW TO CHECK	PRECAUTIONS
Batteries and Battery Compartment (with Batteries installed)	Two Weeks	Inspect batteries for leaks or swelling. Clean battery compartment with solution of baking soda (Sodium Bicarbonate) and water when corrosion is discovered.	Battery compartment must be thoroughly dry before installing batteries. Insure range switch is turned off before storing instrument.
Batteries and Battery Compartment (without Batteries installed)	Monthly		
Exterior Instrument Surface	Monthly	Wipe with clean, dry cloth to remove all dirt and dust.	None
Headset and Connecting Jack	Monthly	Remove dirt and inspect connections	None
Operational Check (Stored with batteries installed)	Two Weeks	Perform operational check as outlined in Section IV, Paragraphs 4-3 and 4-4 (Steps 1 thru 12).	
Operational Check (Stored without batteries installed)	Monthly		

SECTION VI  
MAINTENANCE INSTRUCTIONS

6-1. INTRODUCTION. Scheduled maintenance is that maintenance required to be performed on the equipment at regular scheduled intervals whether or not the equipment is in use. The purpose of scheduled or preventive maintenance is to keep the equipment in good working order and to ensure proper performance when the equipment is needed. Repairs to the Radiacmeter will be annotated on the AFTO Form 140 accompanying the unit.

6-2. SCHEDULED MAINTENANCE ACTION INDEX. The maintenance checks and procedures of Table 6-1 shall be performed at the intervals indicated unless the intervals are modified by the Officer-in-Charge.

TABLE 6-1. SCHEDULED MAINTENANCE ACTION INDEX

INTERVAL	MAINTENANCE ACTION	REFERENCE
Monthly (M)	Check that the radiacmeter cover screws and calibration access screws are seated firmly.	See Table 5-1 for additional actions.
Monthly (M) & Bi-Weekly	Operational checks	Follow procedures in Table 5-1.

NOTE: No special equipment or special tools are required to perform scheduled maintenance.

6-3. THEORY OF OPERATION. With reference to the Functional Block Diagram, Figure 6-1, the primary power source consisting of two series connected BA-30 (1½ volts) batteries, provides fifty hours of continuous instrument operation. A transistorized power supply converts the three volts from the batteries into a regulated +710 volt GM tube anode voltage and a +4.5 volt output for the computer-indicating circuitry operation. Beta particles (on the 0.5 and the 5.0 mR/hr ranges) and gamma rays on all ranges cause the Geiger tubes to produce voltage pulses which are then fed through a differentiating amplifier to a pulse generator followed by a meter drive circuit. The pulse generator provides pulses to the headphone for aural monitoring and supplies a DC current, proportional to the average pulse repetition frequency to the indicating meter.

Power for all functional blocks is obtained through the low voltage power supply. The regulated power supply circuit assures that all operating voltages are maintained constant throughout the useful life of the batteries (battery life is 50 hours, under normal operating conditions).

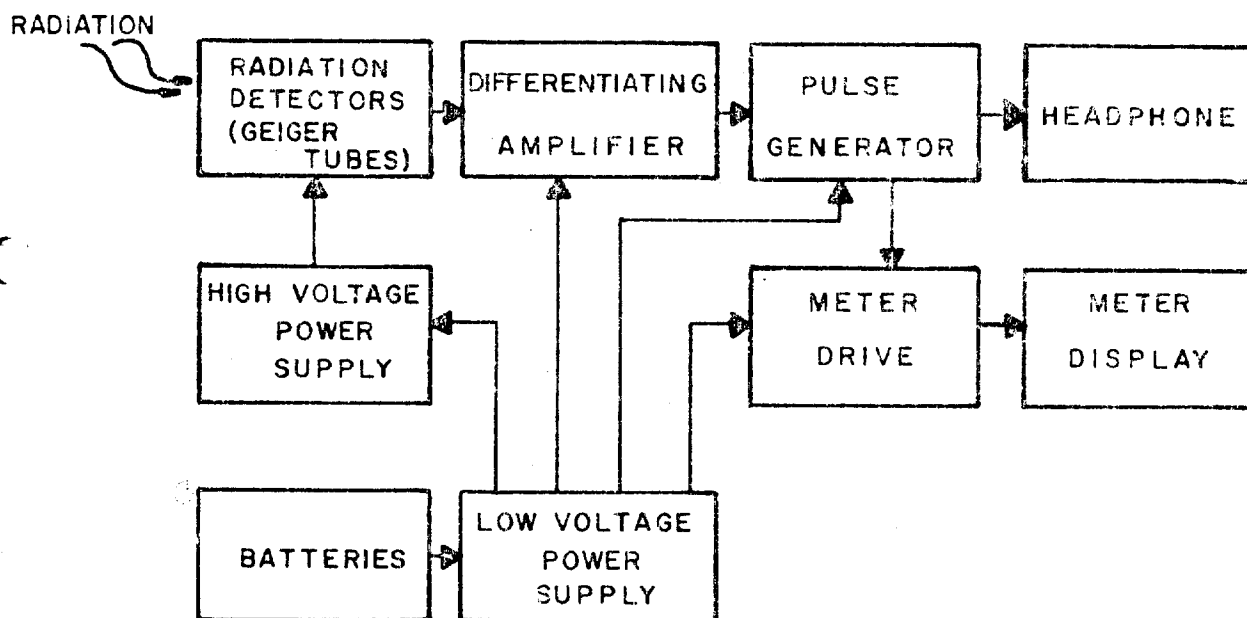
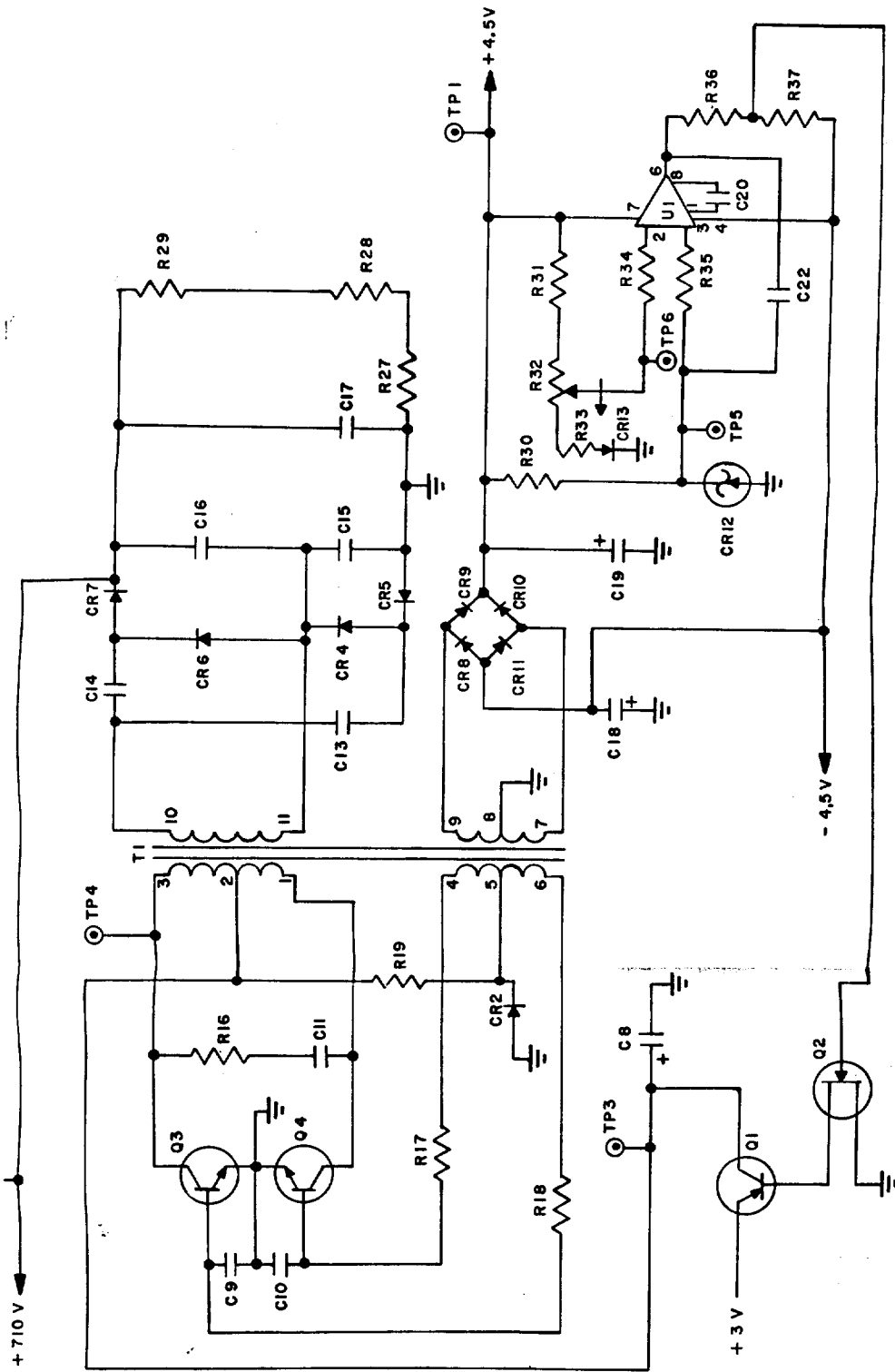

FIGURE 6-1. FUNCTIONAL BLOCK DIAGRAM

#### 6-4. FUNCTIONAL SECTIONS.

a. Power Supply. Refer to Figure 6-2, Power Supply Schematic. Transistors Q3, Q4 and Transformer T1 operate as a free running saturating oscillator that induces, by virtue of the transformer turns ratio substantially larger AC voltage across the secondary windings 10-11 and 7-8-9. The AC voltage is converted to DC as follows:

(1) Winding 10-11 voltage quadrupler consisting of CR4 to CR7 and C13 to C16 for a +710 volt output.



(2) Winding 7-8-9 full wave rectifier consisting of CR9, CR10 and C19 for a +4.5 volt output.

(3) Winding 7-8-9 full wave rectifier consisting of CR8, CR11 and C18 for a -4.5 volt output.

Voltage regulation is accomplished by sensing any change in the +4.5 volt output by the divider string of R31, R32, R33 and CR13, and applying this change to an input gate of the operational amplifier U1. Any change with respect to the 2.4 volt micro-current zener reference diode, CR12, results in an output current to the base of control FET Q2. The output of Q2 drives the regulator transistor Q1, which supplies the power for the oscillator. In general, for the same output voltage, the collector impedance of Q1 must be decreased as the battery voltage decreases. All other outputs are stabilized to the regulated +5 volt supply through the controlled oscillator transformer T1. R32 is the output voltage adjust and CR13 corrects the operational amplifier output for zener reference variations over the full operating temperature range.

b. Radiation Detectors (Refer to Figure 6-3). The 710 volt power supply output supplies power to the two Geiger tubes, V1 and V2 through the range switch S1. The contacts of the range switch are connected to supply voltage to V1 only in the 0.5 mR/hr and 5.0 mR/hr ranges while V2 is energized at all times (on all four ranges).

When radiation causes either of the Geiger tubes to discharge, a negative voltage pulse is generated across R2 or R11 and coupled to the pulse counting circuit (computer) through C6 or C7.

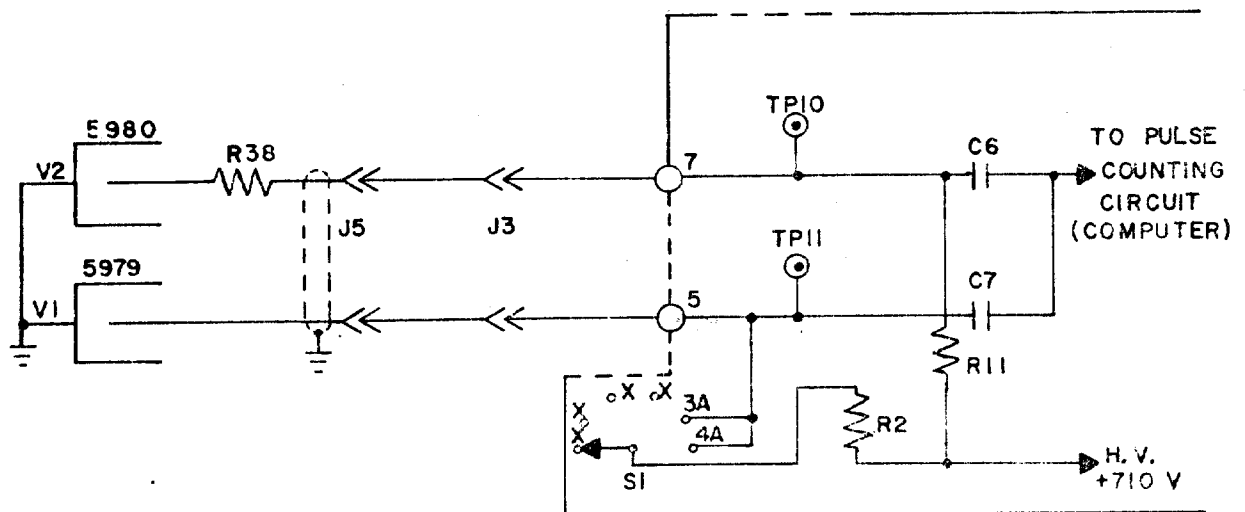

FIGURE 6-3. RADIATION DETECTORS



c. Computer Circuit. (Refer to Figure 6-4). The pulse from the Geiger tube is coupled to the input of transistor Q5. The amplifier Q5 is normally biased "on". A negative going pulse turns Q5 off for the duration of the input pulse. CR1 is a protection diode that protects the base of Q5 from being damaged by large negative input pulses. The positive pulse formed on the collector of Q5 turns the amplifier inverter transistor Q6 "on" for the duration of the input pulse. The negative pulse on the collector of Q6 is differentiated by the network of C12 and R15 and this differentiated pulse is impressed on the base of the switch transistor Q7. Diode CR3 is used as a clamp to clamp the positive part of the differentiated pulse to 0.5 volts to protect the base of Q7 from being damaged.

Transistors Q8 and Q10 form a monostable multivibrator. The normal state of the monostable multivibrator corresponds to full conduction (saturation) of Q10 by its base being connected to the positive 4.5 volts DC supply through one of the following resistor networks, depending on the setting of range switch S1. The following shows the associated timing capacitor used with each range.

<u>RANGE</u>	<u>RESISTOR NETWORK</u>	<u>TIMING CAPACITOR</u>
0.5 mR/hr	R3, R4	C5
5.0 mR/hr	R5, R6	C4
50 mR/hr	R7, R8	C3
500 mR/hr	R9, R10	C2

Transistor Q8 is normally "OFF" since its base is returned to ground through R26 and saturated transistor Q10. Transistor Q9 is an amplifier whose collector is connected to the meter M1 through R23 and adjustable resistor R22. With Q8 being "OFF" in the normal state, there is no current to flow through the meter M1. In this state, the meter will indicate zero.

When a negative going pulse from the differentiation network arrives at the base of Q7, refer to Figure 6-5, transistor switch Q7 turns on (saturates) and pulls one end of the timing capacitor C2, C3, C4 or C5, depending on the setting of the range switch S1 to ground. This causes a negative pulse at the base of Q10, turning Q10 "OFF". As the collector of Q10 goes to +4.5 volts, Q8 is turned on by the resistor R26. Q8 saturates and holds the timing capacitor at ground while Q7 turns off at the end of the negative input pulse. The action of Q7 and Q8 turning "ON" causes current to flow through R20 and R21. The voltage developed by the current in R20 biases the transistor Q9 "ON" and current flows through Q9, R23, R22 and the meter M1. After a time determined by the value of the timing capacitor and resistor network, the timing capacitor completes its discharge and begins to charge toward the +4.5 volt DC supply through the resistor network.

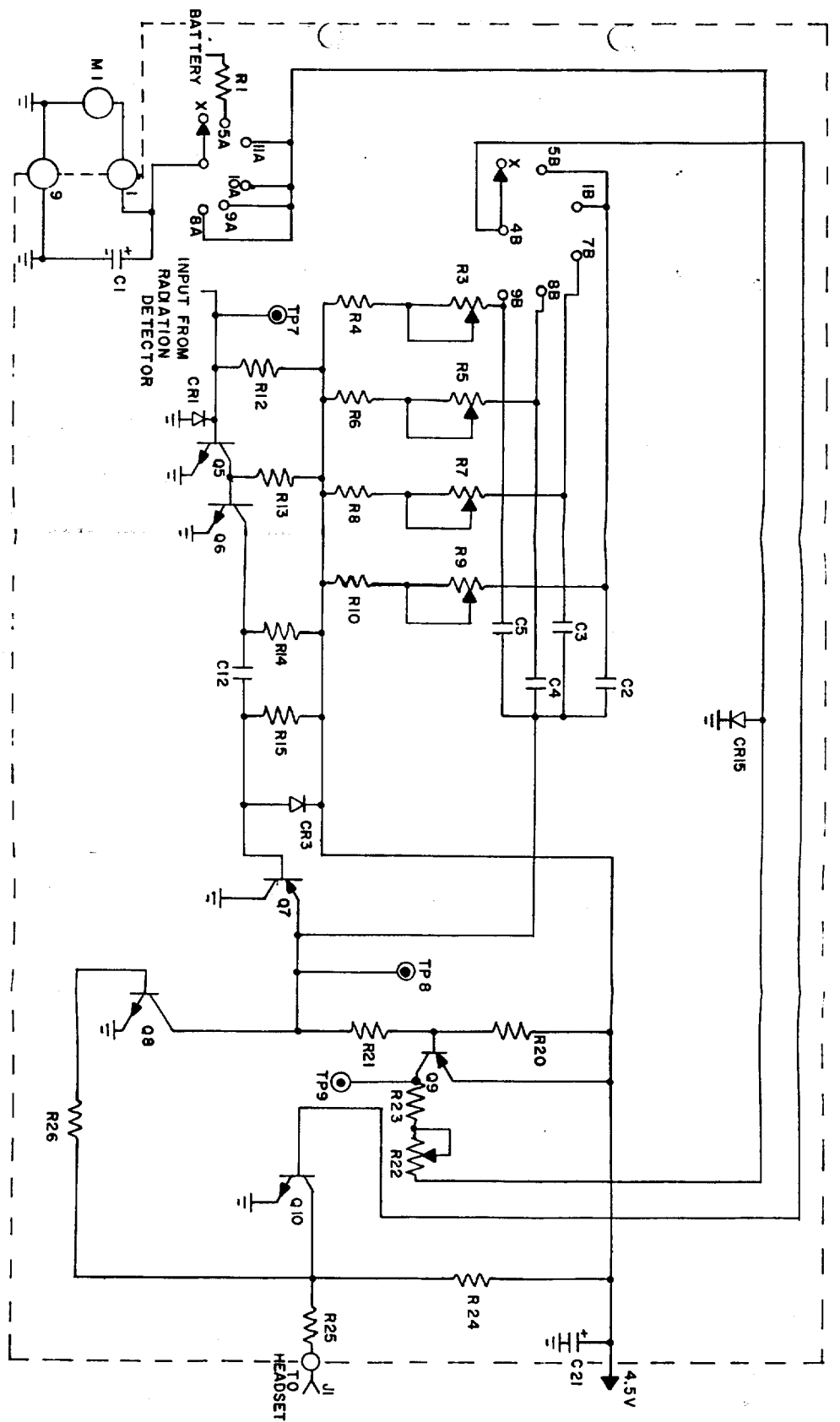

This causes a positive voltage at the base of Q10, turning Q10 "ON" (saturated). This causes the current to the base of Q8 to stop, turning Q8 "OFF", turning OFF Q9, which stops the current flow through the Meter M1. The monostable multivibrator has now returned to its "Normal" state. Thusly, each received pulse from the GM tubes has caused a fixed current to flow through the meter for a fixed time determined by the timing capacitor and resistor network. As long as this fixed conduction time interval is small compared to the average interval between received pulses, the average current which flows through the meter will be directly proportional to the average repetition rate of the received pulses and the meter's indication will be linear. Capacitor C1 smooths out the current pulses to the meter so that rapid fluctuations are suppressed. Diode CR15 protects the meter against damage from over voltage. The pulses at the collector of Q10 are fed to the head-phone jack J1 via R25 for aural monitoring.

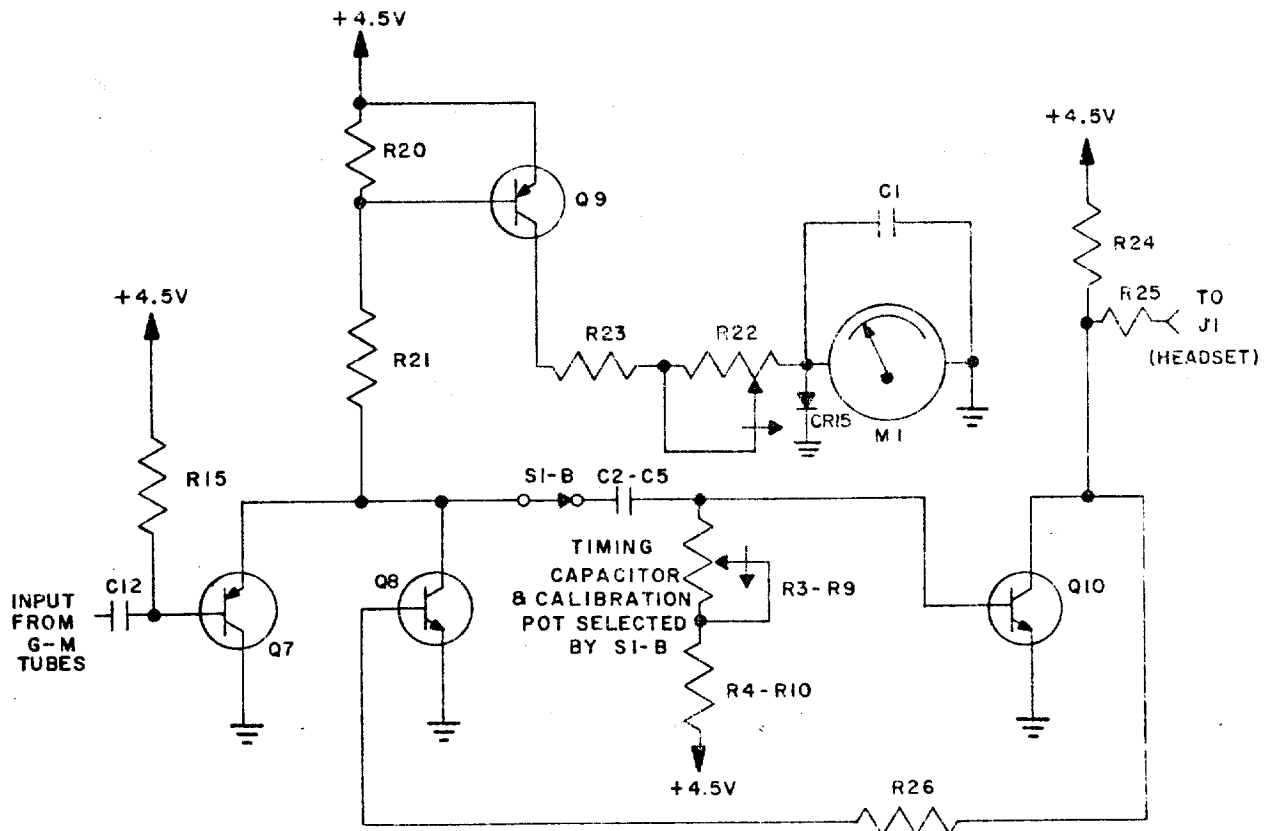

FIGURE 6-5. MONOSTABLE MULTIVIBRATOR

6-5. TROUBLESHOOTING, GENERAL. Troubleshooting of the radiac-meter will be easier if an orderly procedure is used. Procedures in this section are intended to help localize trouble in defective components quickly.

a. Symptom Recognition. This is the first step in the troubleshooting procedure and is based on a complete knowledge and understanding of equipment operating characteristics. All equipment troubles are not the direct result of component failure. Therefore, trouble in an equipment is not always easy to recognize since all conditions or less than peak performance are not always apparent. This type of equipment trouble is usually discovered while accomplishing preventive maintenance procedures. It is important that the "not so apparent" troubles, as well as the apparent troubles, be recognized. See Table 6-2 for Maintenance Turn-on Procedures.

b. Symptom Elaboration. After an equipment trouble has been "recognized", all available aids designed into the equipment should be used to further elaborate on the original trouble symptom. Use of front panel controls and other built-in indicating or testing aids should provide better identification of the original trouble symptom. Also checking or otherwise manipulating the operating controls may eliminate the trouble.

TABLE 6-2. MAINTENANCE TURN-ON PROCEDURE

STEP	OBSERVE	REFERENCE
1. Preliminary Procedure a. Examine instrument case for mechanical damage. b. Turn range switch to its various positions. c. Examine meter. d. Remove battery cover.	Proper switch indexing.  If meter needle is bent.  If meter mechanical zero is not properly set.  Cleanliness of battery contacts. Proper installation of batteries.	Paragraph 4-2, 6-7a.2.  Paragraph 6-7a.3.  Paragraph 6-7a.4
2. Set range switch in BAT position.	Meter should indicate within the area marked BATTERY.	Paragraph 4-4b, Step 2
3. Set range switch in "500" position.	Meter should indicate zero.	Paragraph 4-4b, Step 3
4. Set range switch in "50" position.	Meter should indicate zero.	
5. Set range switch in "5" position.	Meter could indicate slight background.	
6. Set range switch in "0.5" position.	Meter should indicate slight upscale indications due to background radiation.	
7. Set range switch in "50" position and expose to check source (TS101)	Meter should read upscale.	Paragraph 4-4b, Step 7
8. Set range in "5" position and expose to check source.	Meter should read upscale.	Paragraph 4-4b, Step 8

c. Listing Probable Faulty Function. The next step in logical troubleshooting is to formulate a number of "logical choices" as to the cause and likely location (functional section) of the trouble. The logical choices are mental decisions which are based on knowledge of the equipment operation, a full identification of the trouble symptom, and information contained in this manual. The overall functional description and its associated block diagram should be referred to when selecting possible faulty functional sections. See Figure 6-1 and Table 6-3.

d. Use of Test Points. Troubleshooting of the AN/PDR-27T, NSN 6665-01-120-5978, has been greatly simplified by display of many test points. The faulty circuit can be rapidly determined by comparing the observed waveform against the normal pattern shown in Figure 7-3.

6-6. TROUBLESHOOTING INDEX.

TABLE 6-3. TROUBLESHOOTING INDEX, RADIACMETER IM-238/PDR-27.

FUNCTIONAL AREA	TROUBLESHOOTING PARAGRAPH	TROUBLESHOOTING TABLE	FUNCTIONAL DESCRIPTION PARAGRAPH	ALIGNMENT
Overall	6-3, 6-7a	6-4	6-4	
Power Supply	6-4a, 6-7b	6-5	6-4a	Table 6-5
Radiation Detectors	6-4b	6-4	6-4b	Para.6-10b
Computer Circuit	6-4c, 6-7b	6-6	6-4c	Para.6-10c

6-7. TROUBLESHOOTING PROCEDURES.

a. Preliminary Check - General. Before proceeding with any electrical tests, the following mechanical inspection procedure should be followed:

- (1) The instrument housing should be examined for any mechanical damage.
- (2) The range switch should be turned to its various positions to see that the switch knob and meter scales index properly.

(3) The meter should be examined. Observe the meter needle to see that it is not bent. Observe whether the needle is mechanically zeroed. (Meter zeroing may be accomplished by removing the radiacmeter from its housing and turning the meter zero adjusting screw located on the rear of M1. (See Figure 6-6). A clearance hole is provided in the printed circuit board for this purpose.

(4) The battery cover should be removed, and the battery contacts inspected for cleanliness. Check to insure that the batteries have been properly installed and that the battery condition (BATT on selector switch) indicates satisfactorily.

(5) The instrument housing should now be opened by loosening the six captive screws holding the housing and cover together. Visually examine the internal assembly.

(6) Turn the range switch S1 and observe the operation of the switch to see that it appears to be working satisfactorily.

#### WARNING

With batteries installed, advancing the range switch, even to BATT, puts the radiacmeter in operation. High voltage (710 volts), is present at many places on the printed wiring board and also at V1 and V2 anode. Exercise extreme caution when working on the exposed chassis or probes.

Any troubles found in the above steps should be corrected before proceeding any further. The instrument should be prepared for operation and the procedure followed as indicated in Table 6-2. References should be made to Figure 4-1 and Figure 4-2.

#### b. Power Supply and Computer Circuit.

(1) Preliminary Check. After determining from Steps 7 and 8 of Table 6-4 that the power supply is operating improperly, proceed as follows: Visually inspect all connections and printed wiring for breaks.

(2) Use of Troubleshooting Charts. Follow the procedures as indicated in Tables 6-5 and 6-6. References should be made to Figures 6-1 through 6-5 and Paragraphs 6-4a through c.

All voltage measurements made with selector switch in BATT position.

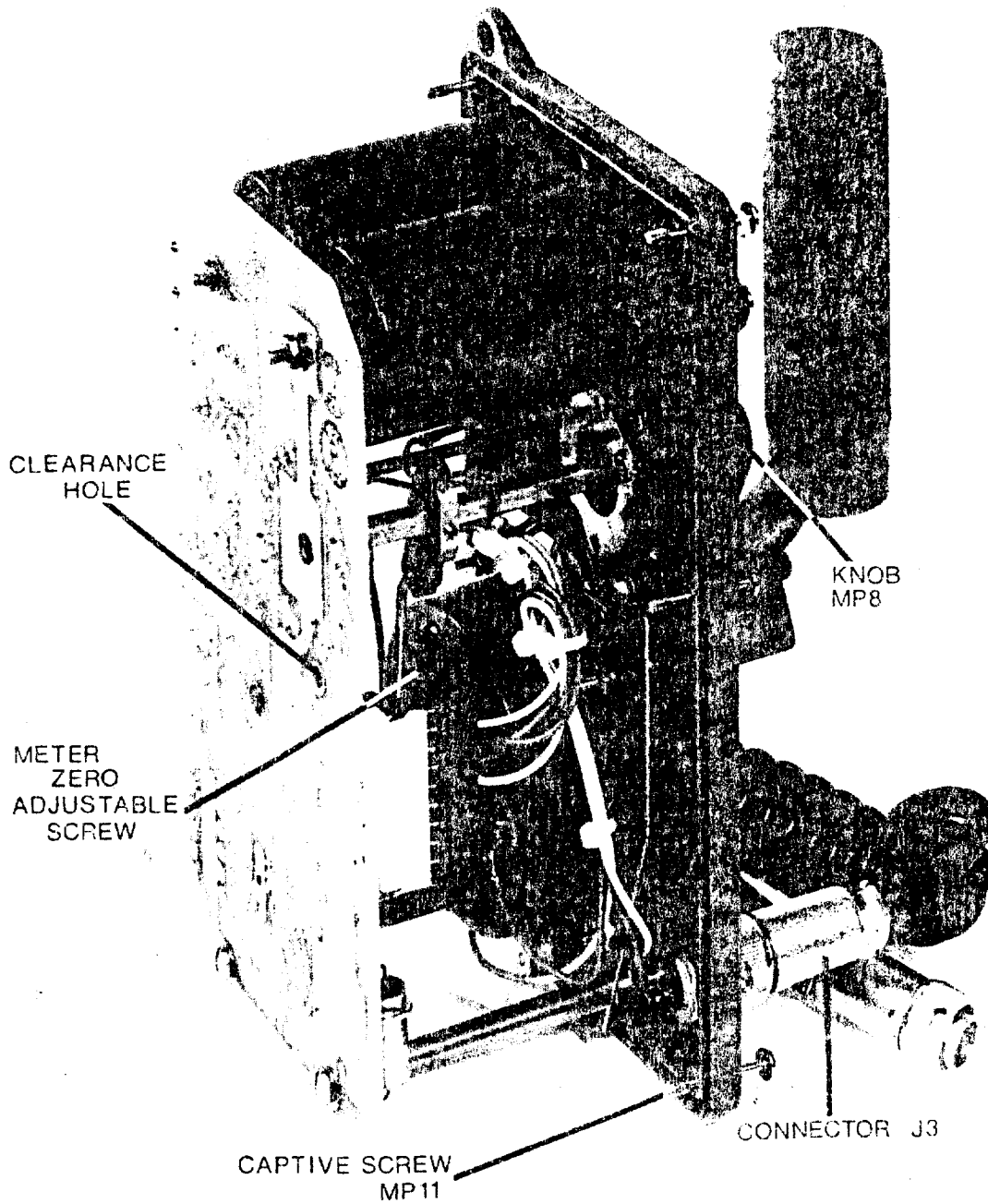

FIGURE 6-6. RADIACMETER IM-238A/PDR-27T, RIGHT SIDE



## 6-8. REPAIR.

General. Radiacmeter AN/PDR-27T has been designed for ease of maintenance. No tools other than the usual service tools are required. A pencil type soldering iron will be useful, particularly the type that can accommodate an in-line desoldering tip when removing integrated circuits. Care should be taken when soldering to apply minimum heat to avoid burning nearby leads and components. A heat sink (such as long nose pliers, alligator clips, etc.) is required when soldering semi-conductors. Disturb lead dressing as little as possible. Take care to keep foreign particles (dust, smoke, metal filings, solder, etc.) out of the radiacmeter during repair. Be sure to remove the batteries to preclude any possibility of energizing the set during repair. Refer to WARNING at paragraph 6-7a(6).

## 6-9. REPAIR PROCEDURES.

CAUTION

Always remove batteries  
before servicing.

a. Tube Replacement. Both tubes are housed in the probe. V1 is a type 5979 Geiger-Mueller tube and is the low range (0.5 and 5 mR/hr) detector. V2 is a type 5980 Geiger-Mueller tube and is the high range (50 and 500 mR/hr) detector. Refer to Figure 6-7.

CAUTION

The cathode end of V1 has a thin and delicate mica window. Do not allow any sharp pointed object to touch the mica window.

(1) To replace V1, unscrew both the window cover assembly 2A2MP31 and the rear (cable end) knurled nut 2A3MP45.

(2) Using fingers or long-nose pliers, pull off anode contact 2A3MP49 and push out tube.

(3) Remove "O" ring seal 2A2MP33 and install on new tube. Assemble in reverse order.

(4) To replace V2, unscrew the small knurled nut 2A3MP50 and pull tube and mounting board out of probe.

(5) Replace V2 and reinsert board assembly 2A3A1 in probe, making sure that board is positioned toward large probe while re-assembling.

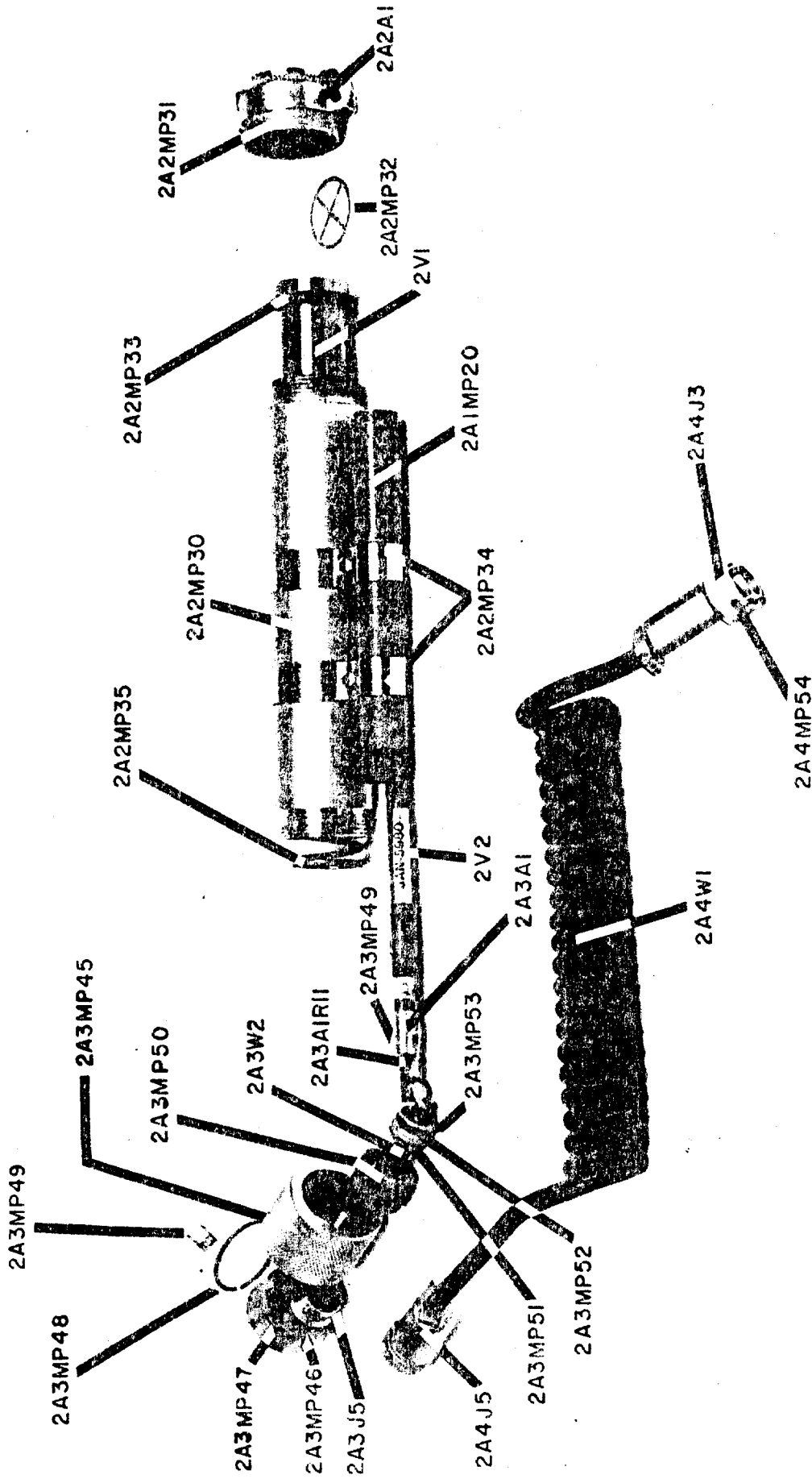

FIGURE 6-7. RADIAC PROBE, DT-613/PDR-27T DISASSEMBLED

b. Printed Circuit Board Removal and Replacement. See Figure 6-8.

- (1) With switch in OFF position, unscrew six captive screws on top panel and remove panel from housing.
- (2) Remove connector from PCB.
- (3) Remove two 6/32 screws, two #6 nuts and hardware holding P. C. board 1A1 to radiacmeter.
- (4) Reconnect new board assembly and reassemble in reverse order, carefully aligning shafts of calibration controls.

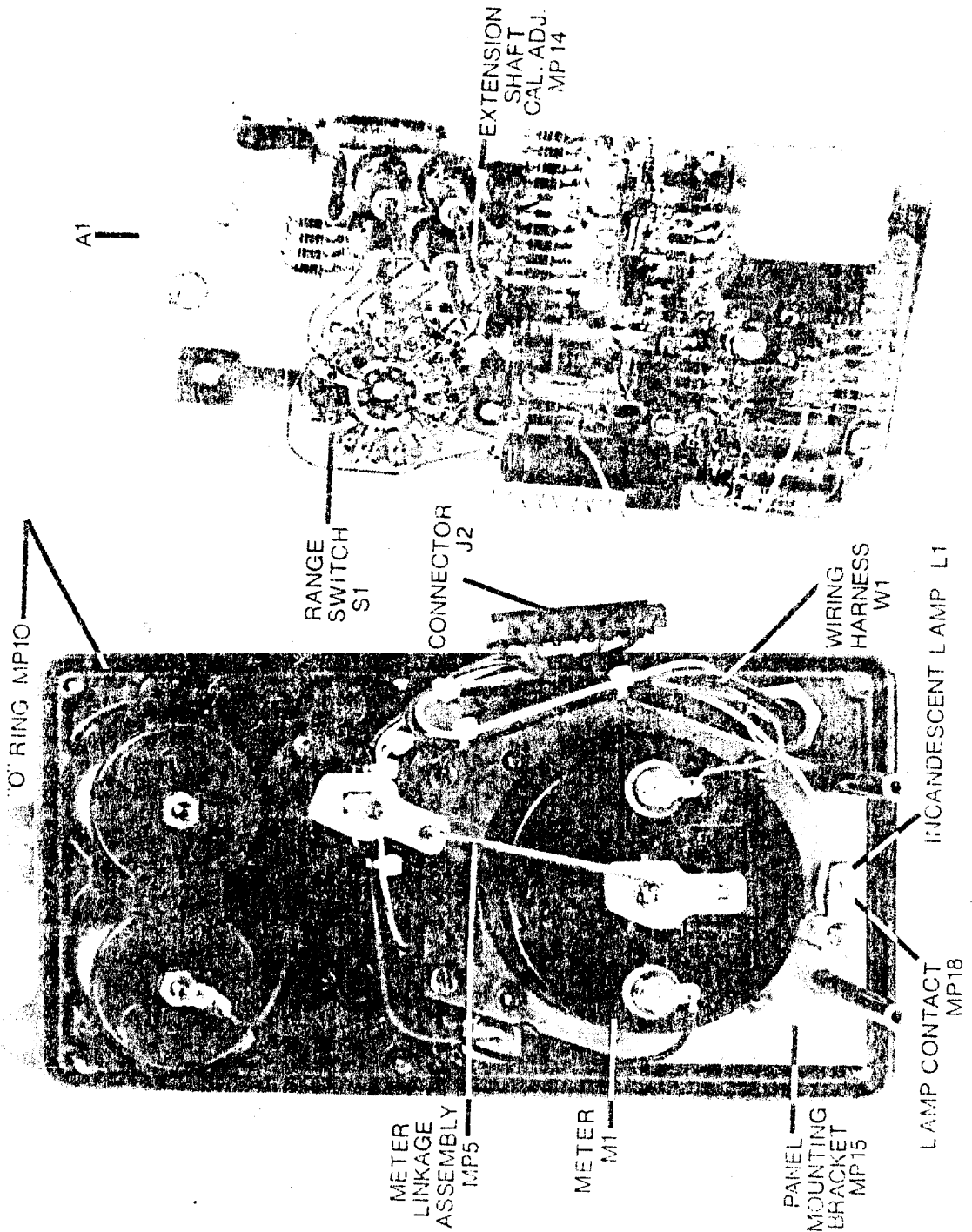

FIGURE 6-8. REAR VIEW, TOP PANEL

TABLE 6-4. RADIACMETER IM-238/PDR-27T SYSTEM TROUBLESHOOTING CHART

STEP	TEST POINT FIGURES	PRELIMINARY ACTION	NORMAL INDICATION	NEXT STEP
1		Set selector switch in BATT position.	Meter should indicate within the area marked BATTERY.	Replace batteries if they do not check good. If there is no meter indication and the batteries are known to be good, check M1, S1 and the applicable circuitry to and from S1.
2		Set selector switch in "500" position.	Meter should indicate zero.	Observe whether indication is correct and then go to Step 3
3		Set selector switch in "50" position.	Meter should indicate zero.	Observe whether indication is correct and then go to Step 4
4		Set selector switch in "5" position.	Meter could indicate slight background.	Observe whether indication is correct and then go to Step 5.
5		Set selector switch in "0.5" position.	Meter should indicate occasional upscale background kicks.	If meter indication is correct on Steps 2, 3, 4 and 5, then refer to Step 6. If meter indication is incorrect on Steps 2, 3, 4 or 5, go to Step 6.
6		Utilize a low level source of radiation (such as Test Source TS101 or equivalent)	Each range should read upscale when source is placed in close proximity to probe.	If radiacmeter responds, the unit may just require calibration. If unit fails to respond, then proceed to Step 7.
7	TP-2 (Fig. 6-2)	Connect the ground lead of a 0-1 KV electrostatic voltmeter to the chassis or BATT, then connect the high side to Test Point 2.	Voltmeter should be $+710 \pm 5$ volts DC. Adjust R32 for correct value.	If reading is correct, go to Step 8. If proper reading is not obtained, refer to Power Supply Troubleshooting Chart, Table 6-5.

STEP	TEST POINT FIGURES	PRELIMINARY ACTION	NORMAL INDICATION	NEXT STEP
8	TP-1 (Fig. 6-2)	Connect a multimeter or a digital voltmeter between ground and Test Point 1.	Voltmeter should read $4.6 \pm 0.3$ volts DC.	If proper readings are not obtained, refer to Power Supply Troubleshooting Chart, Table 6-5. If reading is correct and unit is not performing, go to Step 9.
9		Substitute spare tubes (see paragraph 6-9a for V1 and V2) and repeat Steps 2 thru 5.	Same as Steps 2, 3, 4 and 5.	If trouble is corrected, replace the faulty tube. If the trouble persists, replace the original tube and refer to Table 6-6.

TABLE 6-5. POWER SUPPLY CIRCUIT TROUBLE ANALYSIS

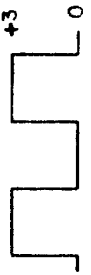
STEP	TEST POINT	TEST EQUIPMENT	RADIAC METER CONTROLS	NORMAL INDICATION	IF INDICATION IS NORMAL	IF INDICATION IS ABNORMAL
1	TP-1 (Fig. 6-2)	Multimeter or Digital Voltmeter	Selector to BATT	4.6 ± 0.3 VDC	Proceed to Step 5.	If voltage is low, proceed to Step 2. If voltage is high, proceed to Step 3.
2	TP-4 (Fig. 6-2)	Oscilloscope & 1:1 Probe	Same as 1. Also, disconnect GM probe from panel.		If waveform is correct and 4.6 was low, check CR9 and CR10, C19 & transformer winding 7, 8 and 9. If both TP-1 and TP-4 voltages are correct, proceed to Step 5.	
3	TP-5 (Fig. 6-2)	Multimeter or Digital Voltmeter	Same as 1.	2.3 ± 0.2 VDC	Proceed to Step 5.	If CR12 voltage is high, replace CR12.
4	(Fig. 6-2)		Same as 1. Apply short across R37.	Power Supply outputs should go from high to low.		If outputs stay high, check Q1 and Q2. If voltage goes low, replace U1.
5	TP-2 (Fig. 6-2)	0-1 KV	Same as 1.	+710 ± 5 VDC.	Trim as necessary by R32 and repeat Step 1, if necessary.	-710 volts is set by R32. Note that 4.60 output is affected by adjustment of R32. If output is low and cannot be adjusted, check CR4, 5, 6 and 7 and C13, 14, 15, 16, 17.

STEP	TEST POINT	TEST EQUIPMENT	RADIACMETER CONTROLS	NORMAL INDICATION	IF INDICATION IS NORMAL	IF INDICATION IS ABNORMAL
1	TP-7 (Fig.6-4)	Pulse Gen. thru 0.01 mf cap. to TP7 (Set pulse gen. output to 1V at 102 Hz ± 0.5 Hz). Oscilloscope.	Selector to 500 mR		Proceed to Step 2.	Check and Readjust Pulse Gen.
2	TP-8 (Fig.6-4)	Same as 1.	Same as 1.		Proceed to Step 4.	Proceed to Step 3.
3	Base of Q7 (Fig.6-4)	Same as 1.	Same as 1.		Check Q7, Q8, Q10, R26, R9, R10, C2 & S1.	Check CR1, CR3, Q5, Q6, C12 and R15.



TABLE 6-6. COMPUTER CIRCUIT TROUBLE ANALYSIS (Continued)

STEP	TEST POINT	TEST EQUIPMENT	RADIACMETER CONTROLS	NORMAL INDICATION	IF INDICATION IS NORMAL	IF INDICATION IS ABNORMAL
4	TP-8 (Fig.6-4)	Same as 1.	Selector to 50 mR.	<p>A timing diagram showing two pulses. The first pulse is at +4V and has a duration of 9800 μs. The second pulse is at 0V and has a duration of 220 to 660 μs.</p>	Proceed to Step 5.	Check R7, R8, C3 and S1.
5	TP-8 (Fig.6-4)	Same as 1.	Selector to 5 mR.	<p>A timing diagram showing two pulses. The first pulse is at +4V and has a duration of 9800 μs. The second pulse is at 0V and has a duration of 100 to 270 μs.</p>	Proceed to Step 6.	Check R5, R6, C4 and S1.
6	TP-8 (Fig.6-4)	Same as 1.	Selector to 0.5 mR	<p>A timing diagram showing two pulses. The first pulse is at +4V and has a duration of 9800 μs. The second pulse is at 0V and has a duration of 1000 to 2700 μs.</p>	Proceed to Step 7.	Check R3, R4, C5 and S1.

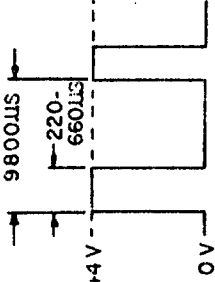
STEP	TEST POINT	TEST EQUIPMENT	RADIACMETER CONTROLS	NORMAL INDICATION	IF INDICATION IS NORMAL	IF INDICATION IS ABNORMAL
7	TP-9 (Fig. 6-4)	Same as 1.	Selector to 50 mR.		Proceed to Step 8.	Q9, R20, R21
8	M1 & Full Scale Reading	Multimeter or Digital Voltmeter	Same as 7.	70 mV dc	Check M1.	Check R23, R22, CR15, S1 and C1.

c. Meter Replacement. See Figure 6-8

- (1) Unscrew and remove the calibration port cover from the top panel.
- (2) Remove the P. C. board as outlined in paragraph 6-9,b.
- (3) Loosen 4-40 screw holding clamp on meter flag shaft and remove clamp from meter.
- (4) Remove two round stand-offs and hardware from front of meter bracket.
- (5) Remove two 6-32 screws and hardware from rear of meter bracket.
- (6) Unsolder meter wires, note color code and polarity.
- (7) Pivot meter bracket to the side permitting access to the four 6-32 meter mounting screws. Remove four 6-32 screws and hardware.
- (8) Remove and install new meter in reverse order.
- (9) Place meter clamp over flag shaft and turn range switch to 50 mR/hr position.
- (10) Using long nose pliers, rotate flag shaft to center white 10-50 scale. Tighten 4-40 clamp screw.
- (11) Check all ranges for scale alignment and readjust clamp position if necessary.

d. Meter Illumination Switch Replacement. See Figure 6-8 and 6-9.

- (1) Remove meter mounting bracket as outlined in paragraph 6-9c (1) through (5).
- (2) Remove three 8-32 screws holding handle from rear of panel and tilt the handle.
- (3) Place common bladed screwdriver down hole in handle and in between terminals of switch to prevent rotation as the boot hex nut, IH1, is unscrewed from the top panel handle mount (3/8 spintite).

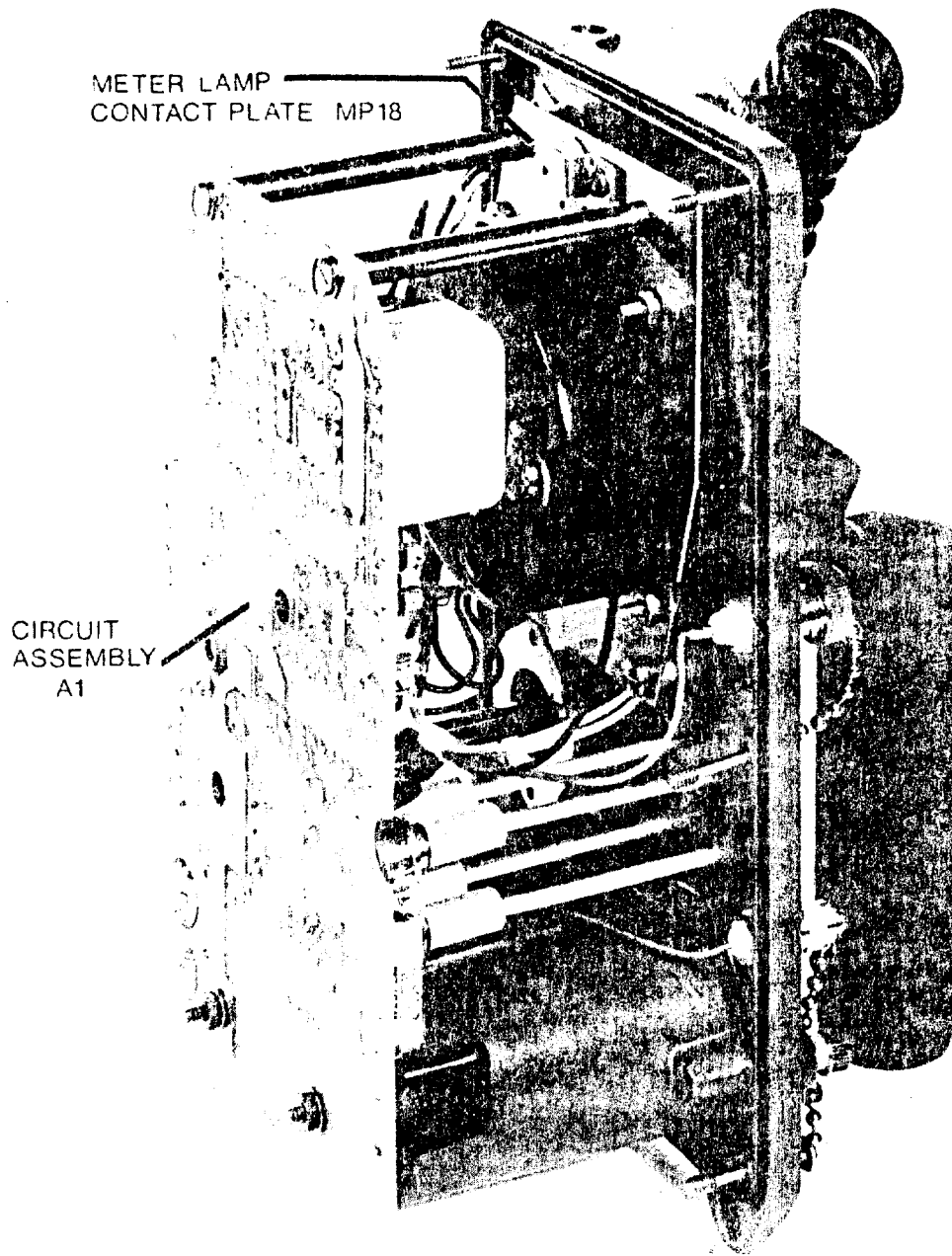

FIGURE 6-9. RADIACMETER IM-238/PDR-27T, LEFT SIDE

(4) Pull switch out of handle mount, cut or unsolder the two wires, install new shrink tubing over the wires, resolder to new switch terminals (no polarity), slip tubing over terminals and using heat of soldering iron, shrink to terminal.

(5) Push switch into mounting hole using screwdriver between the terminals and screw on boot 1H1.

(6) Reassemble meter mounting bracket as outlined in paragraph 6-9, c (8) through (11).

e. Range Switch Replacement. See Figures 6-8 and 6-9.

(1) Remove P. C. Board Assembly 1A1 as outlined in paragraph 6-9, b.

(2) Unsolder the switch wafer from the P. C. Board and solder new switch wafer.

(3) Loosen 4-40 clamp linkage screw on rear of switch shaft. Remove clamp from shaft.

(4) Loosen two 4-40 set screws in knob using a 0.050 allen wrench. Remove knob.

(5) Remove nut and hardware from switch shaft using  $\frac{1}{2}$ " spintite.

(6) Mount and fasten new switch shaft. Fasten knob. Set screw in rear of knob must run into flat surface on switch shaft.

(7) Place meter mechanism clamp over switch shaft and turn switch to 50 mR/hr position.

(8) Rotate meter flag until white 10-50 scale is centered. Tighten 4-40 clamp screw on switch shaft.

(9) Check all ranges for scale alignment and readjust clamp position if necessary.

f. Meter Lamp Replacement. See Figures 6-8 and 6-9.

(1) Remove radiacmeter from housing.

(2) Loosen lamp contact screws.

(3) Using fingers or pliers, pivot lamp 1L1 contact plate 1MP18 toward front of unit. Replace lamp.

6-10. ADJUSTMENT AND CALIBRATION.

WARNING

Calibration of the Radiacmeter may be undertaken only at an authorized radiac repair facility by qualified technicians since the radioactive sources required for complete calibration can be personnel hazardous.

a. General. Radiacmeter AN/PDR-27T is calibrated at time of manufacture. Recalibration is usually not required unless certain critical components are replaced or there is evidence that the four ranges do not track each other properly (See Table 8-1 for list of critical components).

b. Equipment Required For Calibration. The special test equipment outlined in Table 2-1 is adequate for complete equipment calibration or troubleshooting.

(1) A stand and equipment to adequately position and hold the radiacmeter and probe in a fixed relation to the radiation source used.

(2) A small screwdriver.

c. Pre-alignment. If electronic repair or replacement has been performed on the radiacmeter, basic adjustments or alignment must be certified before attempting source calibration. Proceed as follows:

(1) Withdraw radiacmeter from its housing. Remove calibration cover.

(2) Check batteries, replace if necessary and turn range switch to 500 mR/hr.

(3) Adjust R32 for  $710 \pm 5$  volts at TP-2.

(4) Check low voltage for 4.4 - 4.9 volts at TP-1.

(5) Connect a pulse generator, high side, to TP-7 through a 0.01 mfd, (100 volt minimum) capacitor. Set generator for  $1024 \pm 5$  pps, negative going, 1 volt amplitude.

(6) Connect an oscilloscope probe (either 1:1 or 10:1) to TP-9.

(7) Adjust 1R9 to provide a pulse width of  $35 \pm 1$  microsecond at TP-1.

(8) Adjust R22 for a 430 mR/hr meter reading.

d. Source Calibration. For routine calibration or calibration after a detector tube replacement only a source calibration need be performed. The radiacmeter does not have to be removed from its housing. All range potentiometers are accessible after removing the calibration port cover.

#### CAUTION

The energy response of the radiacmeter (flat within 20% from 80 keV to 2 MeV) is such that a dip in response occurs at 662 keV, the characteristic radiation from Cs-137. Whenever Cs-137 is used as a calibrating source, it is necessary to allow for this dip in response in order to obtain the optimum overall energy response accuracy from the radiacmeter. For this reason, the Cs-137 field intensities tabulated in this manual are set up higher by a factor of 1.2 times the corresponding Co-60 fields. Other field intensities may be used, provided that the Cs-137 field is always made 1.2 times the value that the radiacmeter will be adjusted to indicate.

(EXAMPLES: If a 360 mR/hr Cs-137 field is set up in place of a 300 mR/hr Co-60 field, and the 500 control is adjusted to make the meter read 300 mR/hr, a correct calibration will be obtained. Another way of making a correct calibration would be to divide the Cs-137 field intensity by 1.2 to calculate the value that the radiacmeter will be adjusted to indicate. In other words, set up a 300 mR/hr Cs-137 field and adjust the 500 adjustment to make the meter read 250 mR/hr. In general, it is preferred to calibrate near the upper end of the scale, (such as 60 to 80% of full scale).

A Co-60 field of 300, 30, 3 or 0.3 mR/hr or a Cs-137 field of 360, 36, 3.6 or 0.36 mR/hr is an example. The accuracy of the field should be  $\pm 2\%$ .

(NOTE THAT OTHER FIELD INTENSITIES MAY BE USED).

(1) Check battery condition, replace batteries if necessary.

(2) Place the radiacmeter on the radiation range test stand in such a manner that the meter can be read. Position the probe assembly either horizontally or vertically such that the plane of both detectors is perpendicular to the source and not shielded by the radiacmeter itself. Distances must be measured to the plane of the detectors in calculating the intensity of radiation.

(3) Set up each of the four fields listed below with the range switch on the corresponding range position.

RANGE SWITCH	DESIRED METER READING	Co-60 FIELD INTENSITY	Cs-137 FIELD INTENSITY	CALIBRATION POTENTIOMETER
500 mR/hr	300 mR/hr	300 mR/hr	360 mR/hr	1R9
50 mR/hr	30 mR/hr	30 mR/hr	36 mR/hr	1R7
5 mR/hr	3 mR/hr	3 mR/hr	3.6 mR/hr	1R5
0.5 mR/hr	0.3 mR/hr	0.3 mR/hr	0.36 mR/hr	1R3

(4) Set the meter to the correct reading by adjusting the proper calibration control for the range in question as labeled on the top panel.

(5) After an adjustment of a calibration control, allow about one minute to determine the average meter reading.

(6) Replace the calibration port cover and turn instrument off.



## SECTION VII

## DIAGRAMS

7-1. INTRODUCTION. This section contains diagrams and schematics covering the complete unit as follows:

a. Overall Schematic. Figure 7-1. The schematic shows all the electrical circuits of the radiacmeter. Those parts within the dotted line are on the printed circuit board 1A1.

b. Chassis and Switch Wiring. Table 7-1. The wiring of the radiacmeter is relatively simple and is listed in its entirety in Table 7-1.

c. Parts Location. Figure 7-2 shows the printed wiring board assembly 1A1, parts location for all components within the dotted lines of Figure 7-1 and test point locations.

d. Test Point Waveforms. Figure 7-3 shows a graphic presentation of the actual voltages and waveshapes taken at the test points on 1A1. This information should greatly facilitate troubleshooting of the radiacmeter when used in conjunction with the Tables of Section VI.

TABLE 7-1. WIRING RUN LIST

<u>WIRE COLOR</u>	<u>TYPE</u>	<u>FROM</u>	<u>TO</u>
Black	E-22/MIL-W-16878	M1	Gnd Lug
Black	E-22/MIL-W-16878	Gnd.Lug	J2-9
Grey	E-22/MIL-W-16878	J1	J2-3
Orange	E-22/MIL-W-16878	S2-1	J2-2
Red	E-22/MIL-W-16878	M1+	J2-1
Yellow	E-22/MIL-W-16878	S2-2	L1
Green	E-22/MIL-W-16878	J4	Batt + Lug
Brown	EE-22/MIL-W-16878	J3-1	J2-7
White	EE-22/MIL-W-16878	J3-2	J2-5
Black	E-22/MIL-W-16878	J3-3	Gnd.Lug

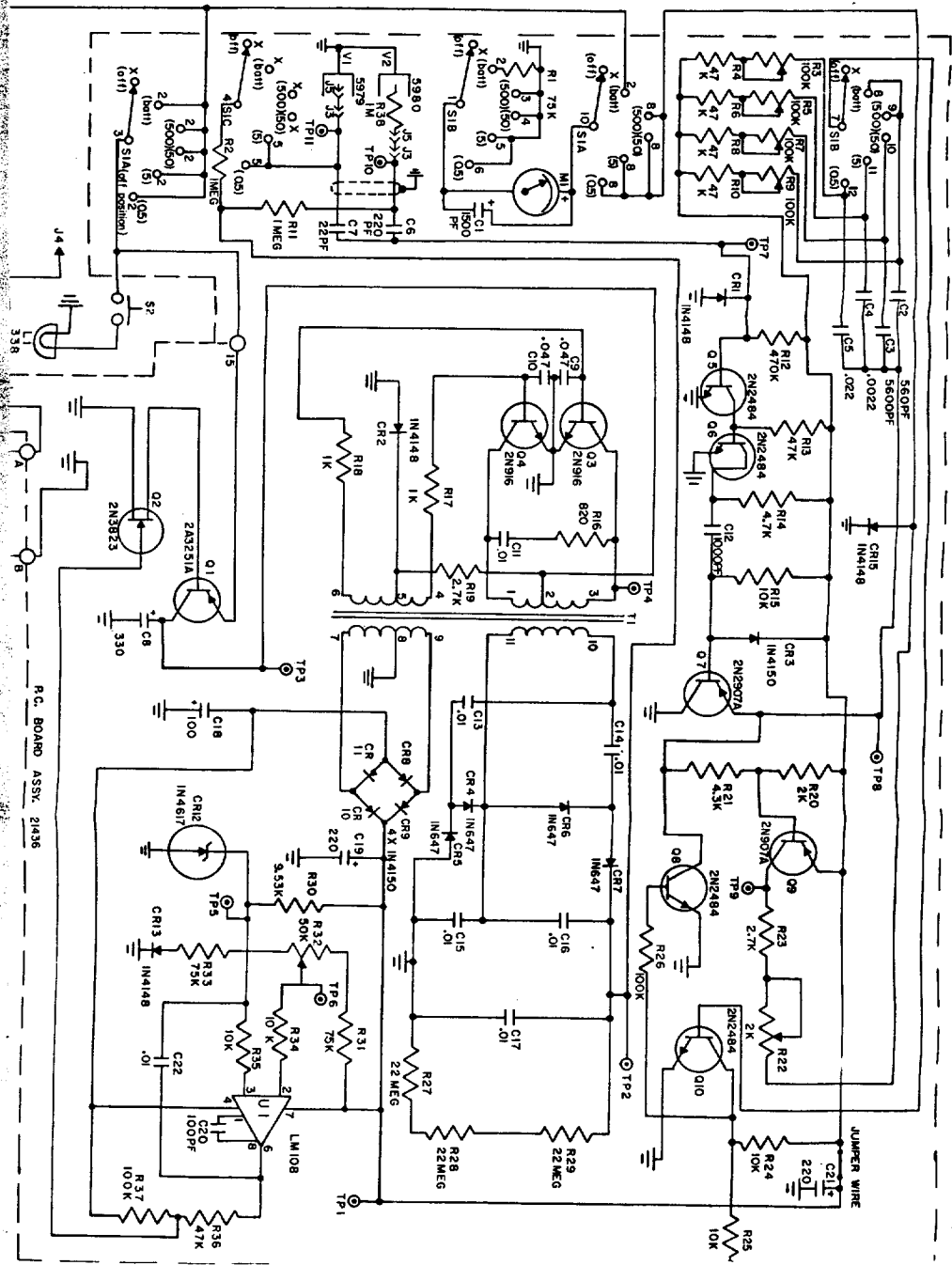

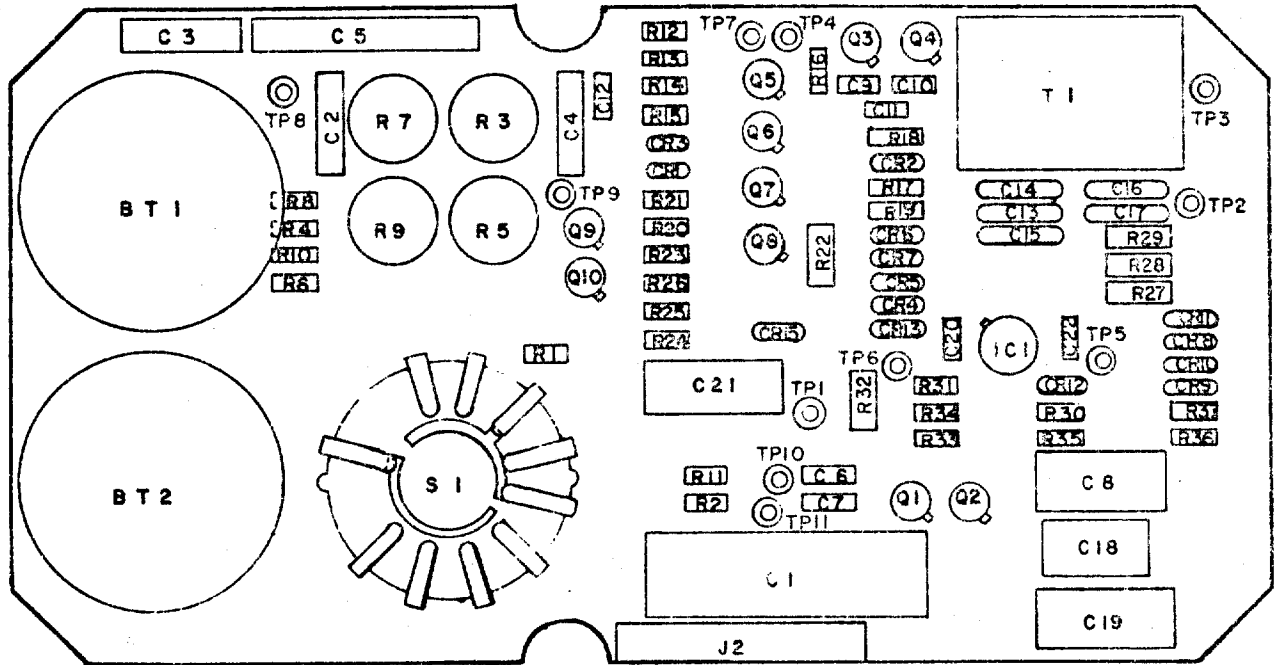

FIGURE 7-2. PARTS LOCATION, PRINTED WIRING BOARD ASSEMBLY 1A1

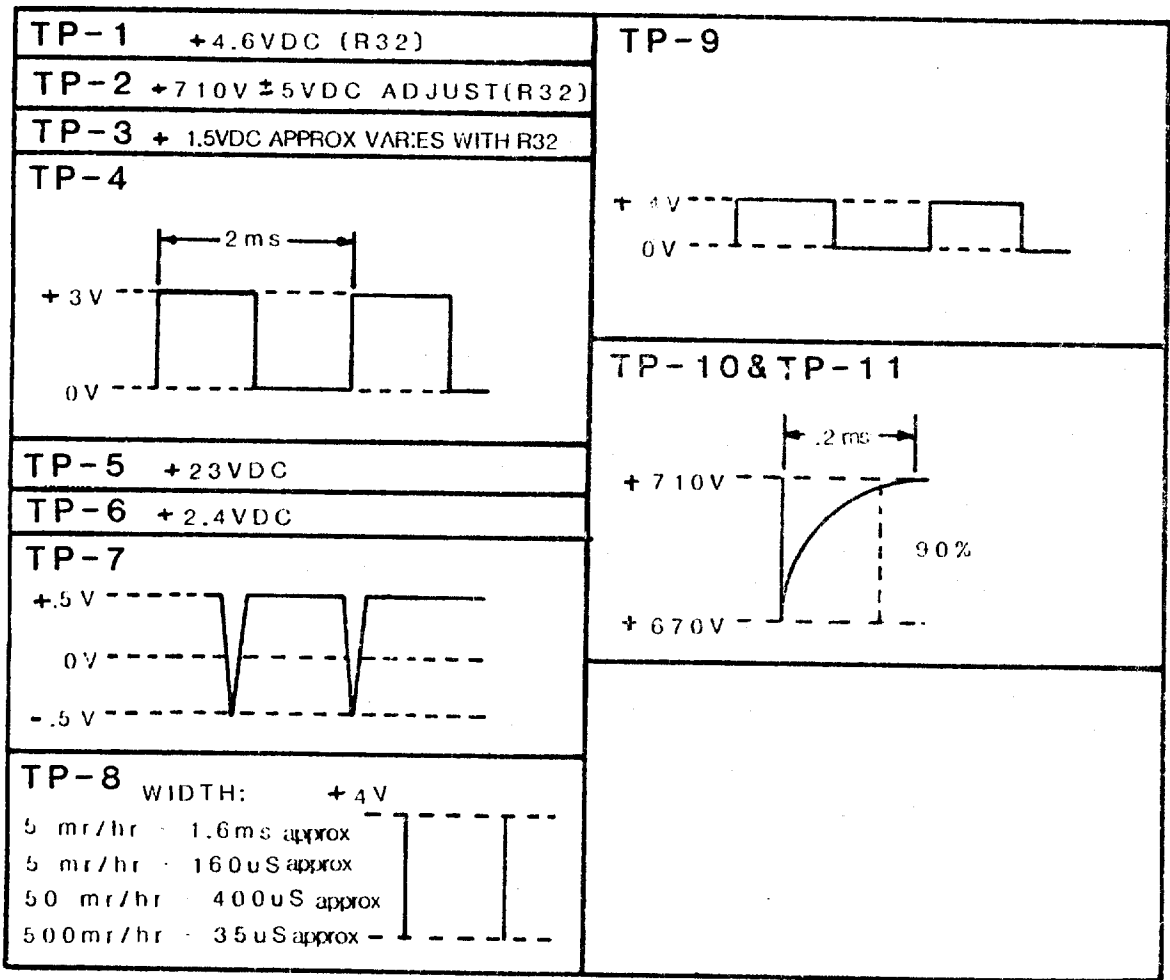

FIGURE 7-3. TEST POINT WAVEFORMS

## SECTION VIII

## PARTS LIST

8-1. INTRODUCTION. This parts list (Table 8-1) is applicable for Radiac Set, AN/PDR-27T, MSN 6665-01-120-5978 only. Reference designations have been assigned to identify all maintenance parts of the equipment. The first digit in the reference designation is one (1) for all parts in the radiacmeter less the coil cord and probe assembly whose associated parts are designated by two (2). Those parts which are part of the printed circuit board assembly are designated 1A1. Following the initial sub-assembly designation, a letter or letters describing the type of part (BT for Battery, C for Capacitor, V for Tube, etc.). The last number indicates which of a group of similar parts is being designated. Example; 1AC3 is Capacitor C3 located on the printed circuit board. The name and description of the part provides a more complete description of the part including the supplier and part number where applicable. The figure and item numbers indicate the figure number where the part is shown and the call out used to designate the part on that figure.

8-2. LIST OF MANUFACTURERS. Table 8-2 lists the manufacturers of all parts. The first column includes the abbreviations used in Table 8-1 to indicate the manufacturer. The second and third columns show the full name and address of each manufacturer.

TABLE 8-1. RADIAC AN/PDR-27T, NSN 6665-00-557-0000 PARTS LIST

REFERENCE DESIGNATION	NOTES	NAME AND DESCRIPTION	FIGURE AND ITEM
		Radiac Set, AN/PDR-27T measures Gamma, detects Beta, 4 ranges 0-500, 50, 5 and 0.5 mR/hr, MIL-R-24061	1-1
		Case, Radiac Set CY-7779A/PDR-27T	1-1
		Arctic Battery Kit, BK-101, NRC P/N B6820	4-7
1HT1		Radioactive Test Sample, NRC TS101	1-1
1MP1		Headset, H43B/U, NRC P/N C3898	1-1
		Carrying Strap, A6957	1-1
2V1	2	Tube, Electron, Spare, JAN5979, NRC P/N VT5979	1-1
2V2	2	Tube, Electron, Spare, JAN5980, NRC P/N VT5980	1-1
1 and 2		Radiacmeter, IM-238/PDR-27T and Probe DI-613/PDR-27T	1-1
1BT1		Battery, Dry 1.5 volt, BA-30 Type "D" Cell	4-2
1BT2		Same as 1BT1	4-2
1H1		Boot, dust and moisture seal; MIL type M5423/10-01	4-2
1J1		Connector, BNC Series, M39012/21-0001	4-2
1J2		Connector, Housing, NRC P/N A6824	6-8
1Li		Lamp, Incandescent, GE338	6-8
1M1	2	Meter, 50 Microamperes DC full scale deflection $\pm$ 2%. Scale, changing Five Scales Off, Battery, 0-500 mR/hr, 0-50 mR/hr, 0-5 mR/hr and 0-0.5 mR/hr. MIL-M-10304/18A Type MR36M201, Spec. R., NRC P/N 600676	6-8

TABLE 8-1. RADIAC SET, AN/PDR-27T, NSN 6665-00-557-3150 PARTS LIST

REFERENCE DESIGNATION	NOTES	NAME AND DESCRIPTION	FIGURE AND ITEM
1J3		Connector, 3 Pin, NRC P/N 600677	6-6 J3
1J4		Connector, Co-axial, NRC P/N 600681	4-1 J4
1MP2		Battery Cover Assembly, NRC P/N B3361	4-2 MP2
1MP3		Gasket, Battery Cover, NRC P/N B1045	4-2 MP3
1MP4		Screw, Captive, NRC P/N 600683	4-1 MP4
1MP5		Meter Linkage Assembly, NRC P/N A6858	6-8 MP5
1MP6		Gasket, Cal. Adj. Cover, NRC P/N A6775	4-2 MP6
1MP7		Handle, NRC P/N C1025-1	4-2 MP7
1MP8		Knob, Range Selector, NRC P/N 600450	6-6 MP8
1MP9		Window, Meter, Plastic Acrylic, MIL-P-5425B, 1/16" Thick, NRC P/N B1042	4-2 MP9
1MP10		"0" Ring, Panel, MS9021-168	6-8 MP10
1MP11		Screw, Captive, NRC P/N B1088-3	6-6 MP11
1MP12		Cover, Cal. Adj., NRC P/N A6763	4-2 MP12
1MP13		Screw, Captive, NRC P/N A7037	4-2 MP13
1MP14		Extension Shaft, Cal. Adj., NRC P/N A6771	6-8 MP14
1MP15		Panel Mounting Bracket Assembly, NRC P/N A6859	6-8 MP15
1MP16		Case, Bottom, NRC P/N C6605	4-2 MP16

REFERENCE DESIGNATION	NOTES	NAME AND DESCRIPTION	FIGURE AND ITEM
1MP17		Cap, Connector, CW123 A/U	4-2 MP17
1MP18		Contact, Lamp, NRC P/N A3367	6-8 MP18
1MP19		Cap, Chain Assembly, NRC P/N A6774	4-2 MP19
1S1		Switch, Range, Shaft, NRC P/N B3907	6-8 S1
1S2		Switch, Push, Momentary, Grayhill Type 3044-2034	4-2 S2
1W1		Harness, Wiring, NRC P/N B6823	6-8 W1
1A1		Circuit Assembly, NRC P/N C6589	6-9 1A1
1A1C1		Capacitor, Fixed, Electrolytic, 1500 mf, 6 VDC, Sprague Type 500D158G06FH7	7-2 C1
1A1C2	2	Capacitor, Fixed, Mica, 560 pf, 200 VDC, CM06FD561J03	7-2 C2
1A1C3	2	Capacitor, Fixed, Mica, 5600 pf, 200 VDC, CM07FD562J03	7-2 C3
1A1C4	2	Capacitor, Fixed, Mica, 2200 pf, 200 VDC, CM06FD222J03	7-2 C4
1A1C5	2	Capacitor, Fixed, Mylar, 22000 pf, 100 VDC, CQR07A1QB223J3L	7-2 C5
1A1C6		Capacitor, Fixed, Ceramic, 220 pf, 1KVDC, CK60AX221K	7-2 C6
1A1C7		Capacitor, Fixed, Ceramic, 22 pf, 1KVDC, CK60BX220K	7-2 C7
1A1C8		Capacitor, Fixed, Tantalum, 330 mf, 6 VDC, M39003/G1-2252	7-2 C8
1A1C9		Capacitor, Fixed, Ceramic, 0.047 mf, 200 VDC, M39014/G1-1427	7-2 C9



TABLE 8-1. RADIAC SET, AN/PDR-27T, NSN 6665-00-557-3150 PARTS LIST

REFERENCE DESIGNATION	NOTES	NAME AND DESCRIPTION	FIGURE AND ITEM
1A1C10		Same as 1A1C9	7-2 C10
1A1C11		Capacitor, Fixed, Ceramic, 0.01 mf, 200 VDC, M39014/01-1415	7-2 C11
1A1C12		Capacitor, Fixed, Ceramic, 1000 pf, 200 VDC, M39014/01-1397	7-2 C12
1A1C13		Capacitor, Fixed, Ceramic, 0.01 mf, 500 VDC, CK63AW103M	7-2 C13
1A1C14		Same as 1A1C13	7-2 C14
1A1C15		Same as 1A1C13	7-2 C15
1A1C16		Same as 1A1C13	7-2 C16
1A1C17		Capacitor, Fixed, Ceramic, 0.01 mf, 1 KVDC, CK63AY103M	7-2 C17
1A1C18		Capacitor, Fixed, Tantalum, 100 mf, 10 VDC, M39003/01-2262	7-2 C18
1A1C19		Capacitor, Fixed, Tantalum, 220 mf, 10 VDC, M39003/01-2266	7-2 C19
1A1C20		Capacitor, Fixed, Ceramic, 100 pf, 200 VDC, M39014/01-1379	7-2 C20
1A1C21		Same as 1A1C19	7-2 C21
1A1C22		Same as 1A1C11	7-2 C22
1A1C21		Semiconductor, Diode, MIL-S-19500/116, Type IN4148-1	7-2 CR1

TABLE 0-1. PARTS LIST, AIR FORCE-2/1, NON 0000-00-00 100 PARTS LIST

REFERENCE DESIGNATION	NOTES	NAME AND DESCRIPTION	FIGURE AND ITEM
1A1CR2		Same as 1A1CR1	7-2 CR2
1A1CR3		Semiconductor, Diode, MIL-S-19500/231, Type IN4150-1	7-2 CR3
1A1CR4		Semiconductor, Diode, MIL-S-19500/240, Type IN647-1	7-2 CR4
1A1CR5		Same as 1A1CR4	7-2 CR5
1A1CR6		Same as 1A1CR4	7-2 CR6
1A1CR7		Same as 1A1CR4	7-2 CR7
1A1CR8		Same as 1A1CR3	7-2 CR8
1A1CR9		Same as 1A1CR3	7-2 CR9
1A1CR10		Same as 1A1CR3	7-2 CR10
1A1CR11		Same as 1A1CR3	7-2 CR11
1A1CR12		Semiconductor, Diode, Zener, MIL-S-19500/435, Type IN4617	7-2 CR12
1A1CR13		Same as 1A1CR1	7-2 CR13
1A1CR14		Not Used	
1A1CR15		Same as 1A1CR1	7-2 CR15
1AIR1		Resistor, Fixed Composition, 75 K ohms, 1/4W, RCR07G753KM	7-2 R1
1AIR2		Resistor, Fixed Composition, 1 M ohms, 1/4W, RCR07G105KM	7-2 R2

TABLE 8-1. RADIAC SET, AN/PDR-27T, NSN 6665-00-557-3150 PARTS LIST

REFERENCE DESIGNATION	NOTES	NAME AND DESCRIPTION	FIGURE AND ITEM
1A1R3		Resistor, Variable, Composition, 100 K ohms, $\frac{1}{2}W$ RV6NAYS1104A	7-2 R3
1A1R4		Resistor, Fixed, Composition, 47 K ohms, $\frac{1}{2}W$ , RCR07G473KM	7-2 R4
1A1R5		Same as 1A1R3	7-2 R5
1A1R6		Same as 1A1R4	7-2 R6
1A1R7		Same as 1A1R3	7-2 R7
1A1R8		Same as 1A1R4	7-2 R8
1A1R9		Same as 1A1R3	7-2 R9
1A1R10		Same as 1A1R4	7-2 R10
1A1R11		Same as 1A1R2	7-2 R11
1A1R12		Resistor, Fixed Composition, 470 K ohms, $\frac{1}{4}W$ , RCR07G474KM	7-2 R12
1A1R13		Same as 1A1R4	7-2 R13
1A1R14		Resistor, Fixed Composition, 4.7 K ohms, $\frac{1}{2}W$ , RCR07G472KM	7-2 R14
1A1R15		Resistor, Fixed Composition, 10 K ohms, $\frac{1}{4}W$ , RCR07G103KM	7-2 R15
1A1R16		Resistor, Fixed Composition, 820 ohms, $\frac{1}{4}W$ , RCR07G821KM	7-2 R16
1A1R17		Resistor, Fixed Composition, 1 K ohms, $\frac{1}{4}W$ , RCR07G102KM	7-2 R17
1A1R18		Same as 1A1R17	7-2 R18

REFERENCE DESIGNATION	NOTES	NAME AND DESCRIPTION	FIGURE AND ITEM
1A1R19		Resistor, Fixed Composition, 2.7 K ohms, 1/4W, RCR07G272JM	7-2 R19
1A1R20		Resistor, Fixed Composition, 2 K ohms, 1/4W, RCR07G202JM	7-2 R20
1A1R21		Resistor, Fixed Composition, 4.3 K ohms, 1/4W, RCR07G432JM	7-2 R21
1A1R22	1	Resistor, Variable Composition, 2 K ohms, 1/2W, RJ24CX202	7-2 R22
1A1R23		Same as 1A1R19	7-2 R23
1A1R24		Same as 1A1R15	7-2 R24
1A1R25		Same as 1A1R15	7-2 R25
1A1R26		Resistor, Fixed Composition, 100 K ohms, 1/4W, RCR07G104KM	7-2 R26
1A1R27		Resistor, Fixed Composition, 22 M ohms, 1/4W, RCR20G226KM	7-2 R27
1A1R28		Same as 1A1R27	7-2 R28
1A1R29		Same as 1A1R27	7-2 R29
1A1R30		Resistor, Fixed Composition, 9.53 K ohms, 1/8 W, RNC55H9531FM	7-2 R30
1A1R31		Resistor, Fixed Composition, 75 K ohms, 1/8 W, RNC55H7502FM	7-2 R31
1A1R32	1	Resistor, Variable Composition, 50 K ohms, 1/2W, RJ24CX503	7-2 R32

TABLE 8-1. RADIAC SET, AN/PDR-27T, NSN 6665-00-557-3150 PARTS LIST

REFERENCE DESIGNATION	NOTES	NAME AND DESCRIPTION	FIGURE AND ITEM
1AIR34		Same as 1AIR15	7-2 R34
1AIR35		Same as 1AIR15	7-2 R35
1AIR36		Same as 1AIR4	7-2 R36
1AIR37		Same as 1AIR26	7-2 R37
1AIT1	1	Transformer, Saturating Oscillator, Encapsulated per MIL-T-27, Grade II, NRC P/N C6894	7-2 T1
1AIU1	1	Semiconductor Device, Integrated Circuit, MIL-M-38510/10104, Type LM108H	7-2 U1/1C1
1AIQ1	1	Semiconductor Device, Transistor, MIL-S-19500/323, Type 2N3251A	7-2 Q1
1AIQ2	1	Semiconductor Device, Transistor, MIL-S-19500/375, Type 2N3823	7-2 Q2
1AIQ3	1	Semiconductor Device, Transistor, MIL-S-19500/271, Type 2N916	7-2 Q3
1AIQ4	1	Same as 1AIQ3	7-2 Q4
1AIQ5	1	Semiconductor Device, Transistor, MIL-S-19500/376, Type 2N2484	7-2 Q5
1AIQ6		Same as 1AIQ5	7-2 Q6
1AIQ7		Semiconductor Device, Transistor, MIL-S-19500/291, Type 2N2907A	7-2 Q7
1AIQ8		Same as 1AIQ5	7-2 Q8

TABLE 8-1. RADIAC AN/PDR-27T, NSN 6665-00-557-30 PARTS LIST

REFERENCE DESIGNATION	NOTES	NAME AND DESCRIPTION	FIGURE AND ITEM
1A1Q9		Same as 1A1Q7	7-2 Q9
1A1Q10		Same as 1A1Q5	7-2 Q10
1A1S1		Switch, Range, Wafer, NRC P/N B3907	4-2 S1
1A1J1		Not Used	
1A1J2		Connector, Post Header, NRC P/N A6824-1	7-2 J2
2		Radiacmeter Probe DT-613/PDR-27T	6-7
2A1MP20		Housing, High Range Probe, NRC P/N A6836	6-7
2A2A1		Cover, Latch Assembly, NRC P/N A6835	6-7
2A2MP30		Housing, Low Range Probe, NRC P/N A6685	6-7
2A2MP31		Nut, Retainer, NRC P/N A6831	6-7
2A2MP32		Guard Window, NRC P/N A6832	6-7
2A2MP33		"O" Ring, Neoprene, MS9021-020	6-7
2A2MP34		Clamp, NRC P/N A6839	6-7
2A2MP35		Spring, Probe P/N A6834	6-7
2A3A1		Assembly, Electron Tube Holder, NRC P/N A6844	6-7
2A3A1R38		Resistor, Fixed Composition, 1 Megohm, $\frac{1}{4}$ W, RCR07G105KM	6-7 R38
2A3MP45		Nut, Retainer, NRC P/N A6670	6-7
2A3MP46		Washer, End Cap, NRC P/N A6671	6-7
2A3MP47		End Cap, NRC P/N A6684	6-7

TABLE 8-1. RADIAC SET, AN/PDR-27T, NSN 6665-00-557-3150 PARTS LIST

REFERENCE DESIGNATION	NOTES	NAME AND DESCRIPTION	FIGURE AND ITEM
2A3MP48		Gasket, NRC P/N A7024	6-7
2A3MP49		Cap, Electrical, NRC P/N 600682	6-7
2A3MP50		Nut, Retainer, NRC P/N A6848	6-7
2A3MP51		Washer, Flat, MS15795-709	6-7
2A3MP52		End Cap, NRC P/N B21412	6-7
2A3MP53		"O" Ring, Neoprene, MS9021-012	6-7
2A3W1		Not Used	
2A3W2		Cable, Jumper, NRC P/N A6843	6-7
2A3J1		Not Used	
2A3J2		Not Used	
2A3J3		Not Used	
2A3J4		Not Used	
2A3J5		Connector, 3 Pin, NRC P/N 600679	6-7
2A4J1		Not Used	
2A4J2		Not Used	
2A4J3		Connector, Plug, 3 Pin, NRC P/N 600678	6-7
2A4J4		Not Used	
2A4J5		Connector, Plug, 3 Pin, NRC P/N 600680	6-7

IMDL 0-1. KADIMV E1, AM/PUR-2/1, NSN 6665-00-55 150 PARTS LIST

REFERENCE DESIGNATION	NOTES	NAME AND DESCRIPTION	FIGURE AND ITEM
2A4W1		Cable, Retractable, NRC P/N A6842	6-7
2A4MP54		"O" Ring, MS28900-10	6-7
2V1	2	Tube, Electron, Geiger Mueller, High Sensitivity MIL-E-1/906B, Type JAN5979, NRC P/N VT5979	6-7
2V2	2	Tube, Electron, Geiger Mueller, Low Sensitivity MIL-E-1/973A, Type JAN5980, NRC P/N VT5980	6-7

NOTES:

- 1) If component is changed, pre-alignment should be performed. Refer to paragraph 6-10,c.
- 2) If component is changed, a source calibration should be performed. Refer to paragraph 6-10,d.



TABLE 8-2. LIST OF MANUFACTURERS

ABBREVIATION	NAME AND FSC	ADDRESS
97539	Automatic & Precision	44 Honeck Street Englewood, NJ 07631
08806	General Electric Miniature Lamp Div.	Nela Park Cleveland, Ohio 44112
81073	Grayhill, Inc.	561 Hillgrove Avenue LaGrange, IL 60525
83330	H. H. Smith, Inc.	812 Sneiker Avenue New York, NY 11207
96696	Nuclear Research Corp.	125 Titus Avenue Warrington, PA 18976
56289	Sprague Electronics	North Admas, MA
01121	Allen Bradley Co.	Milwaukee, WI
91836	Kings Electronic Co., Inc.	Tuckahoe, NY
07263	Fairchild Semi-Conductors	Mt. View, CA
06486	TRW Electronic Comp.	West Lynn, MA
01295	Texas Instruments	Dallas, TX
04222	AUX Ceramics, Inc.	Myrtle Beach, SC