

MARTIN BRUCHANOV OK2MNM

Image Communication on Short Waves

www.sstv-handbook.com

1

Contents

1	Preface	7
2	Slow-scan television	9
2.1	The beginnings	9
2.2	Image transmission	10
3	Modern SSTV features	12
3.1	Signal modulation	13
3.1.1	Bandwidth	13
3.1.2	Modulation techniques of analog SSTV	14
3.2	Image resolution	15
3.3	Line speed	16
3.4	Black & white transmission	16
3.5	Colour transmission	20
3.5.1	Additive colour model	20
3.5.2	Composite colour model	21
3.6	Synchronization	24
3.6.1	Horizontal synchronization	24
3.6.2	Vertical synchronization — VIS code	24
3.6.3	Additional synchronization data	25
4	Formats of slow-scan TV transmission	28
4.1	Black and white SSTV systems	28
4.1.1	Modes for digital converters	28
4.1.2	BW transmission with computer software	29
4.2	Color SSTV modes	30
4.2.1	Wraase SC-1	32
4.2.2	Robot color system	32
4.2.3	The Martin synchronous system	35
4.2.4	Scottie	38
4.2.4.1	Scottie DX – special mode for long distance transfers	39
4.2.5	Amiga Video Transceiver	39
4.2.6	Wraase SC-2	43
4.3	High resolution transmission	44
4.3.1	FAX480	44
4.3.2	Pasokon TV	45
4.3.3	PD modes	46

4.4	Experimental modes	46
4.4.1	MSCAN TV	47
4.4.2	Kenwood FAST FM	47
4.4.3	Modes MP, MR, ML	48
4.4.4	Martin HQ	50
5	List of SSTV modes	53
6	SSTV Equipment	57
6.1	Transceiver	57
6.2	Station equipment for visual communication	57
6.3	Historical tidbits	58
6.3.1	SSTV monitor	58
6.3.2	Scanning devices	60
6.4	Early FSTV/SSTV converters	61
6.5	SUPERSCAN 2001	62
6.6	Tasco TSC-70P	64
6.7	Interactive Visual Communicator VC-H1	65
7	Computer operations	66
7.1	Hardware configuration	66
7.2	Sound card as a modem	67
7.2.1	Sound processing in PCs	67
7.2.1.1	Sampling	67
7.2.2	Analog-to-digital conversion	68
7.2.3	Interface between TRX and PC	70
7.2.4	PTT control	72
7.2.5	Eliminate supply noise	72
7.3	Timing oscillator configuration	73
7.3.1	Transmit timing offset	75
7.4	SSTV tuning	76
7.5	Video digitalization	76
7.6	Software for Windows	77
7.6.1	List of programs	77
7.6.1.1	SSTV software	77
7.6.1.2	Digital mode software with SSTV support	78
7.6.1.3	Software for dedicated interfaces	78

8	Ham radio image operations	79
8.1	The reporting system	82
8.2	SSTV not only for hams	83
8.3	Diplomas and QSL cards	84
8.3.1	IVCA DX Achievement Award DXAA	84
8.3.2	DANISH DX SSTV AWARD	84
8.3.3	Russian SSTV Award	84
8.4	Contests	85
8.4.1	DARC SSTV Contest	85
8.4.2	Russian SSTV Contest	85
8.4.3	NVCG SSTV Contest	86
8.4.4	Danish SSTV Contest	86
8.4.5	JASTA SSTV Activity	86
8.4.6	Ukrainian SSTV Contest	87
8.5	SSTV repeaters	87
8.5.1	HF and 50 MHz repeater list	87
8.6	Ham radio satellites and space broadcast	87
8.6.1	SSTV from Mir station	90
8.6.2	SuitSat	91
8.6.3	Amateur Radio on the International Space Station	92
9	Introduction to digital slow-scan TV	94
9.1	Digital communication basics	95
9.2	Error detection and correction	96
9.2.1	Cyclic redundancy check	98
9.2.2	Hamming code	98
9.2.3	Reed-Solomon code	99
9.3	Data compression	99
9.3.1	Information entropy	100
9.3.2	Huffman coding	101
9.3.3	Lossless data compression	103
9.3.3.1	Portable Network Graphics	103
9.3.4	Lossy compression	104
9.3.4.1	JPEG compression	104
9.3.4.2	JPEG2000	107
9.3.4.3	Lossy versus lossless image compression — conclusion	109

10	DSSTV transmission systems	112
10.1	Redundant Data File Transfer	112
10.1.1	RDFT operations	115
10.2	HamDRM system	117
10.2.1	Comparison of HamDRM and RDFT	120
10.2.2	Quadrature amplitude modulation — QAM	121
10.2.3	Orthogonal frequency-division multiplexing — OFDM	123
10.2.3.1	OFDM transfer	124
10.3	DSSTV software selection	126
10.4	Making QSO	126
10.5	Waterfall images	128
11	Facsimile — Radiofax	130
11.1	The history of image transmission	130
11.2	The fax mode	131
11.2.1	Image transmission	132
11.2.2	The reception	133
11.2.2.1	Facsimile transmission modes	135
11.3	Professional stations	135
11.4	Satellite imagery retransmission	138
11.4.1	Meteorologic satellites	140
11.4.2	Essential Services	142
11.5	Hamradio facsimile operations	142
11.5.1	EU – FAX – Diplom	143
11.5.2	The International HF – FAX – Contest by DARC	143
11.6	International facsimile standard recommendation	144
12	List of professional stations	147
12.1	Europe	147
12.1.1	Athens, Greece	147
12.1.2	Hamburg/Pinnenberg, Germany	147
12.1.3	Roma, Italy	147
12.1.4	Moscow, Russia	148
12.1.5	Murmansk, Russia	148
12.1.6	Northwood, The United Kingdom	148
12.2	Africa	149
12.2.1	Cape Naval, South Africa	149
12.3	Asia	149
12.3.1	Beijing, China	149
12.3.2	Beijing, China	149
12.3.3	Shanghai, China	150

12.3.4	New Delhi, India	150
12.3.5	Tokyo, Japan	150
12.3.6	Pevek, Chukotka peninsula	150
12.3.7	Taipei, China	151
12.3.8	Seoul, Republic of Korea	151
12.3.9	Bangkok, Thailand	151
12.3.10	Kyodo News Agency, Japan	151
12.3.11	Kyodo News Agency, Singapore	152
12.3.12	Northwood, Persian Gulf Base	152
12.4	South America	152
12.4.1	Rio de Janeiro, Brazil	152
12.4.2	Valparaiso Playa Ancha, Chile	152
12.5	North America	153
12.5.1	Halifax, Nova Scotia Canada	153
12.5.2	Iqaluit, NWT Canada	153
12.5.3	Resolute, NWT Canada	153
12.5.4	Sydney, Nova Scotia Kanada	153
12.5.5	Kodiak, Alaska USA	154
12.5.6	Pt. Reyes, California USA	154
12.5.7	New Orleans, Louisiana USA	154
12.5.8	Boston, Massachusetts USA	154
12.5.9	Inuvik, Canada	155
12.6	Australia and Oceania	155
12.6.1	Charleville, Australia	155
12.6.2	Wiluna, Australia	155
12.6.3	Wellington, New Zealand	156
12.6.4	Honolulu, Hawaii USA	156
12.7	List by frequency	157
13	Computer image processing	161
13.1	Image resizing	161
13.2	Color adjustment	162
13.3	Filters	165
13.3.1	Convolution matrix	165
13.3.2	Noise reduction	168
13.3.2.1	Spatial average filtering	168
13.3.2.2	Median filter	170
13.3.3	Sharpening	171

1

Preface

There are various methods used in transferring messages through radio waves. With miscellaneous communication modes that are suitable for use under different conditions, varying in speed of transmission, modulation or data protocol.

And many of them are used by radio amateurs to connect worldwide on short waves, connections over satellite relays or message downloads from local packet-radio BBS on very short waves. The book you are about to read is about image transmission.

The most common method to transfer images is television broadcasting (*Fast-Scan Television*). An analog FSTV broadcast can be produced in amateur conditions too. Both picture and sound transmitted on amateur bands can be received via a regular TV set or by a satellite tuner in the case of frequency modulation. These connections are held only on ultrashort or microwave bands, because the signal needs a large bandwidth and thus the signal can be transported only through relatively small distances.

However the issue of this book is *image transmission on short waves*.

The most popular narrow-band mode for image transmission is SSTV – *Slow-scan Television*. Unlike the classic TV it can broadcast only static images with lower resolution.

An SSTV image is converted to an audio signal, which can then be transmitted over a voice channel by a communication transceiver on shortwave bands. With an expansion of radio broadcast digitalization, digital SSTV was also developed and uses advanced technologies like data compression, error correction codes and discrete multi-tone modulations for relatively fast narrow-band data transfer.

Another option for shortwave image transmission is *radiofax*, the predecessor of what is now commonly known as office fax. Radiofax is mostly used by meteorological stations for the broadcast of synoptic maps and satellite images. Or by press agencies for the broadcast of news (and photographs in the past) on longwave and shortwave bands. Synoptic maps should be transferred in high quality, so image transmission takes about 10 minutes or more on average. Despite the pervasiveness of Internet technology, this broadcast method is still widely used.

For a long time the integral part of our hamshacks has been the personal computer. An essential part of a PC; the sound card inputs signals into the PC. And then specialized software converts the signal to data and vice versa. The data that is of interest in this book will be that of transmitted images.

I hope this book will spur those who are interested in these fascinating modes of communication to get immediately active in the field.

In Žďár nad Sázavou, April 11, 2013

Martin OK2MNM

2

Slow-scan television

Slow-scan television (SSTV) is a mode of communication designed for image transfer. Because SSTV is a narrowband mode, it can be transmitted via voice channels with a standard SSB transceiver on all radio amateur frequency bands. World-wide communication is also possible during good conditions on high frequency bands.

2.1 The beginnings

In 1957 a student at the University of Kentucky, Copthorne “Cop” Macdonalds, WA2BCW (now VY2CM) found an article about a device developed by Bell laboratories for image transmission via telephone lines. The communication system fascinated the ham radio enthusiast because it needed a bandwidth as narrow as that of voice broadcast and could be transferred by regular ham radio transmitters .

Another image mode the radio fax (facsimile) was available then, but it required a long duration (about 20 minutes) for a high resolution image transfer. Such a duration length could not provide an impression of time consistency during a QSO and it also needed an intricate mechanical printer and electrosensitive paper. It was necessary to invent something else.

There was an idea to transfer images coded into audio signals and display them on long persistence displays (CRTs used in radars or slow-scan oscilloscopes).

Then Copthorne started to work on how to transfer images via radio waves with a common ham radio transceiver. Within six months he carried out many experiments with amplitude and frequency modulation, and it resulted in the design of slow-scan television. During the next six months he created an SSTV image scanner, so practical experiments could be done on the ham bands. The first television image crossed the Atlantic on the 20th of December 1959.

During the next ten years Copthorne and a group of amateurs worked on SSTV improvements, and they created the basic standard for SSTV and developed a sampling camera.

Their work was completed in 1968 when the FCC (Federal Communications Commission) formally authorized SSTV operations.

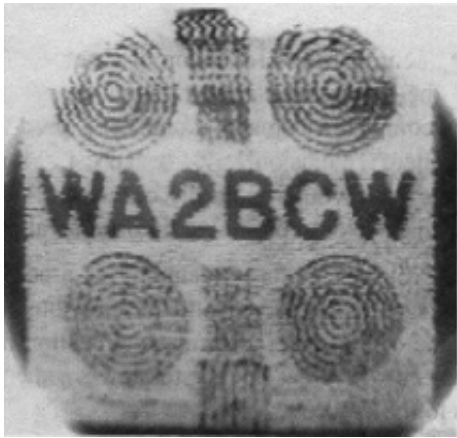

The first image that crossed the Atlantic, received by John Plowman G3AST.



Copthorne
Macdonald's broadcast.

Figure 2.1: Early slow-scan television images.

A few months later ham radio magazines published the first articles about the new communication mode. It led to a huge interest by ham operators and a real SSTV boom.

2.2 Image transmission

The basic idea of SSTV is to transfer television images with the standard transceiver. However, a television broadcast requires a large bandwidth. The reduction of the television signal is achieved by lowering of horizontal (row) and vertical (image) scans, which must be reduced to a minimal frequency. This means that a typical 3MHz signal of black and white television must be reduced to 3 kHz – the reduction of bandwidth is around 1000:1. Nowadays the bandwidth reduction is bigger, because color image needs approx. 6 MHz. Therefore, only static images with lower resolution can be transferred due to the significant bandwidth reduction.

During experiments, it was found that an image was visible for about 8 seconds on a long-persistent CRT with P7 phosphor. So after reception of the last scan-line, the first is still visible, but in a while – the image slowly disappears. For the best impression, it was necessary to view an SSTV monitor in a darkened room. Usually several same images were transmitted in a sequence. Each consequent image slowly redrew the original which was still visible on the phosphor. So it was possible to display images for a longer time or to record it on a tape for later playback.

It was found that the ideal time for the correct detection of line synchronization pulses by electronic circuits is 5 ms and for image (vertical) synchronization it is

30 ms. Vertical synchronization initiates the automatic start up of the image display on the CRT.

The synchronization frequency for scan-lines and frames was derived from the electric mains frequency. For horizontal scan 50 Hz divided by three – 16.6 Hz is used. And for vertical scan $1/7.2 \text{ s} = 0.1388 \text{ Hz}$ is used, this is the mains frequency divided by 360 ($3 \times$ number of lines 120). The parameters are derived in the same way for countries with 60 Hz mains.

The video signal band was chosen in the range from 1500 Hz for black up to 2300 Hz for white. Sync pulses have a frequency of 1200 Hz and because they are “blacker than black” then they do not affect the image information.

All frequency components of SSTV are inside the low-frequency band and it is possible to transfer them via voice channels.

Other SSTV modes came out from this original standard and in most cases; they differ only in scan speed and in the addition of color transmission.

3

Modern SSTV features

A milestone between methods of old and modern SSTV image transmission is without doubt the usage of semiconductor memory chips. The creation of the first converters between fast and slow-scan television signals, was credited to the existence of permanent image storage in memory. Consequently, image transmission could be improved because the usage of long persistence CRTs, which had been a major constraining fact, was now eliminated. Due to it some new formats with longer transmission time were developed. They brought more quality to black and white transmission and helped to develop colour image transmission.

There was a trend in the design of new formats that created several modes in each system. There were modes with faster transmission and lower resolution and on the other hand, modes for the transfer of higher quality images but longer time length. There is a possibility to change between them according to the actual band condition.

The early phases of development were influenced by two companies – the American *Robot Research Inc.* and the German *Wraase Electronic* led by radio amateur Volker Wraase, DL2RZ. Each of them introduced an SSTV converter which used each company's own transmission system. The systems are different in the usage of colour coding, scan line formats and synchronization methods. Their converters provide several modes. *Mode* denotes a format of image transmission, its resolution and transfer speed.

As often happens, the professional device did not fully satisfy ham radio users. So new systems with more modes were implemented into the converter firmware. And they were also re-implemented into other devices to ensure compatibility. Sometimes a new genuine system was designed to overcome imperfections found in the classic predecessors.

The number of those systems has grown unbelievably. Recently they were new systems created for better utilization of modern computer potentials. Modern personal computers with the necessary equipment, are full successors of SSTV converters. The advantage of computers is especially bigger memory and better image resolution.

If we were to count the number of all SSTV modes, we would find approximately 70! So it is possible to transfer SSTV images via seventy different modes, which are mutually different in transmission time, resolution, colour coding, etc. The vast majority of them are absolutely unique and incompatible...

You might be a little scared by the previous paragraphs, but let me reassure you that only a few modes are actually used.

European amateurs widely used the SSTV mode called *Martin M1*, but in recent times other modes; *Martin M2* and *Scottie S2* are also in use. A special mode used *Scottie DX*; is characterized by very high image quality. And the mode *Robot 36 Color* is undertaken in space communication.

Fortunately, all modern converters and computer software are able to operate with these popular modes, so the problem that two stations can not establish the QSO should not occur.

A digital vertical synchronization for automatic mode selection will be described shortly, because every mode uses a digital header for its identification. Thanks to this any SSTV device can automatically switch to the correct mode and begin reception. Computer software also supports mode detection by measuring the elapsed time between two successive sync. impulses of image lines.

More details will be described in the following chapters.

3.1 Signal modulation

3.1.1 Bandwidth

Different communication channels, whether wired or wireless, have several characteristics, which define their behaviour in the transfer of effective signals. These include for example *attenuation*. Attenuation defines how much the communication channel reduces a transferred signal. Another important characteristic is the *bias*, which refers to the various distortions that occurs due to imperfections within the communication path.

There are several negative influences, that affect signal transfer within a communication path. Their effects are not negligible. The intensity of this effect depends also on the frequency of signal. Generally, it is always possible to identify a range of frequencies that a particular transmission path can transfer well and outside this frequency range the transmission is too poor.

The signal bandwidth does not depend only on the frequency range used for modulation, in our case 1,500 Hz to 2,300 Hz, but also on the signal spectrum.

Fourier analysis is used to determine the spectrum bandwidth. The analysis can express any waveform in the form of the sum of a large number of sine waves – harmonic components.

Limited bandwidth has the effect that the harmonic components lying inside this band will be transferred more or less without blemish and other harmonic components pass with a huge distortion or not at all (more in **chapter 7.2.1.1, page 67**).

Bandwidth can be seen as a characteristic of the transmission path given by the range of the signal spectrum.

The basic rule for the required bandwidth is called *Nyquist rate*. Its definition is that optimal bandwidth equals a half of modulation speed. It is true that the necessary bandwidth increases with the amount of transferred information per time unit.

3.1.2 Modulation techniques of analog SSTV

An SSTV broadcast is usually carried out using single-sideband (SSB) amplitude modulation with a common ham radio transceiver. Frequencies above 2,500 Hz are strongly suppressed, so the frequency of white colour, the maximal level of an SSTV signal, was chosen at 2,300 Hz.

SSTV signals are transmitted via frequency modulation of an audio signal. To avoid any phase shift and drift (which both have negative impact on picture quality), the spectrum of video signal is modulated on the auxiliary carrier frequency 1900 Hz – *sub-carrier*. This modulation method is called *Sub-carrier frequency modulation (SFCM)*.

The frequency of video signal varies from black by gray shades to white. The bandwidth needed for SSTV transmission varies in the range of 1.0 to 3.2 kHz and depends on the SSTV mode, transmission speed and also on image content, see **fig. 3.1**.

Cheap modems (based on Hamcomm) do not use perfect continuous harmonic signals, but also create the quantized signal. Step changes between quantization levels require wider bandwidth, so some image details can get lost.

The emission classification code for the SSTV mode is $J3F$, which means:

- ▷ J – Carrier modulation: Single-sideband with suppressed carrier.
- ▷ 3 – Nature of modulating signal: One channel containing analogue information.
- ▷ F – Detail of signal: television signals.

In the case of an SSTV transmission via a frequency modulated (FM) channel, emission is classified as $F3F$ and $A3F$ for amplitude modulation (AM) with both side bands.

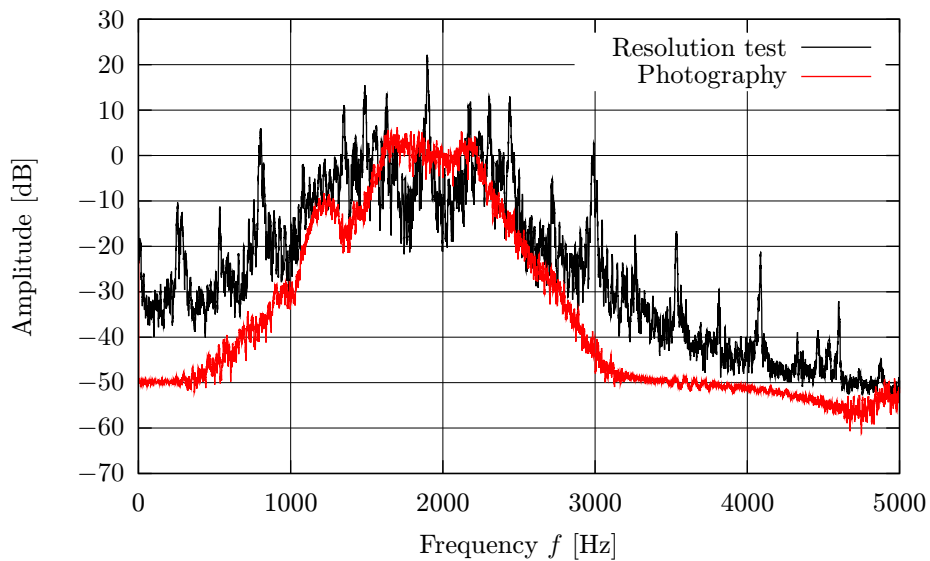

Figure 3.1: The SSTV frequency spectre for two various images transferred in Martin M1 mode.



Figure 3.2: Image quality depends on resolution.

3.2 Image resolution

Resolution is a feature that tells what amount of details is possible to store in an image, see **fig. 3.2**. The resolution has two parameters: *horizontal resolution* – the number of image columns \times number of image lines – *the vertical resolution*.

In television technology the more important parameter is the vertical resolution (number of lines) and it is defined by the selection of the SSTV mode. To get the horizontal resolution is more complicated.

As has been described in previous text, the image is broadcast through the SSB channel on short waves and the maximal bandwidth is limited.

The SSTV is an *analog* mode and cannot transfer images without loss. The image is not exactly the same on the reception side as on the transmission side. Even if the communication channel is without any interference or noise, the image is still distorted due to transmission speed and limited bandwidth. The faster the transmission speed is, the greater the distortion result. Therefore it is very difficult to say what the horizontal resolution of an SSTV image is.

Most of the modes carry images with 240 lines and the image is displayed in a 4:3 aspect ratio on a screen. We can then say that the number of columns is $240 \times 4/3 = 320$. This value then corresponds to a theoretical resolution, but not a *real* image resolution.

The test chart (**fig. 3.3**) is used to qualify the horizontal resolution of images. The resolution pattern contains alternating stripes of black and white in various densities from very rough to fine. There is a comparison of this image with normal photography in **fig. 3.1**.

All SSTV modes in **figure 3.3** have 320 columns. But as we can see, not all can transfer the image in actual quality. The note in brackets describes the approximate time needed for the transfer of one pixel. While with the Martin M2, we can hardly distinguish the second fine grid, the M1 mode with double transmission time can transfer it without problems, but its finest pattern is distorted. Compare it to the real picture in **fig. 3.4**. The last two modes listed have longer times of transmission and can transfer the finest details. Unfortunately, it is hardly compensated for by the slow speed of transmission.

3.3 Line speed

One of the most important parameters that is suitable for SSTV mode selection is the total time required to transfer an image.

Due to present transmission speeds, SSTV is becoming similar to radio facsimile. Therefore, the mode parameters are not defined by horizontal and vertical scan rates, but in the number of lines transferred in one minute – *lines per minute (lpm)*.

Line speed depends on the selected mode and varies in the range from 57 lpm (Scottie DX), for high quality transmission of colour image (320×240) in nearly five minutes, up to 1000 lpm for BW image (128×128) in just 8 seconds. SSTV modes and their properties are described below.

3.4 Black & white transmission

For a black and white (BW) monochromatic image broadcast, only one signal is needed. It represents brightness/luminance Y of each image element.

```
name: sstv/obr/resol/original.png
file: sstv/obr/resol/original.png
state: unknown
```

Test pattern original

```
name: sstv/obr/resol/m2.png
file: sstv/obr/resol/m2.png
state: unknown
```

Martin M2($\sim 220 \mu\text{s}$)

```
name: sstv/obr/resol/r36.png
file: sstv/obr/resol/r36.png
state: unknown
```

Robot 36 Color($\sim 280 \mu\text{s}$)

```
name: sstv/obr/resol/m1.png
file: sstv/obr/resol/m1.png
state: unknown
```

Martin M1($\sim 450 \mu\text{s}$)

```
name: sstv/obr/resol/mp115.png
file: sstv/obr/resol/mp115.png
state: unknown
```

MP115($\sim 680 \mu\text{s}$)



Martin M1

Martin M2

Figure 3.4: The comparison of two modes in real conditions of 14 MHz band.

The frequency ranges from 1,500 Hz (black) to 2,300 Hz (white) transmit image information. Each frequency in this range represents specific brightness – the level of gray.

Human vision can distinguish brightness in a wide range, but can only adapt to the geometric mean value of actual brightness. Around this value about 100 to 110 gray scale levels can be differentiated.

Based on this fact; an ideal transmission could be regarded as 128 gray levels. At this figure, the average observer would not normally see transitions between adjacent grades.

If we want to transmit images in 128 gray levels, this is the distance of signal levels $800 \text{ Hz} / 128 = 6.25 \text{ Hz}$. The lowest frequency is for black and the highest is for white, the remaining 126 gray levels lay in the linear range between these two frequencies.

An issue with the transfer of more gray levels, for example 256 levels, is that it puts an increased demand on the demodulator. The demodulator must be able to compensate for the frequency shift between the transmitter and the receiver. In this case, the distance between the two levels of brightness is 3.125 Hz and it is necessary to have a relatively large distance from the interference on the communication path, to assure a pure transfer of all gray scale.

Normally, we can settle for a less bright resolution where it is possible to choose the transfer of only 64 levels. This requires less of the demodulator because it only needs to distinguish between 12.5 Hz steps.

True reproduction of colour images in gray scale is another issue. Human vision cannot perceive the bright intensity of all three colour components at the same time. When we watch three lights (red, green and blue) of the same intensity, the human

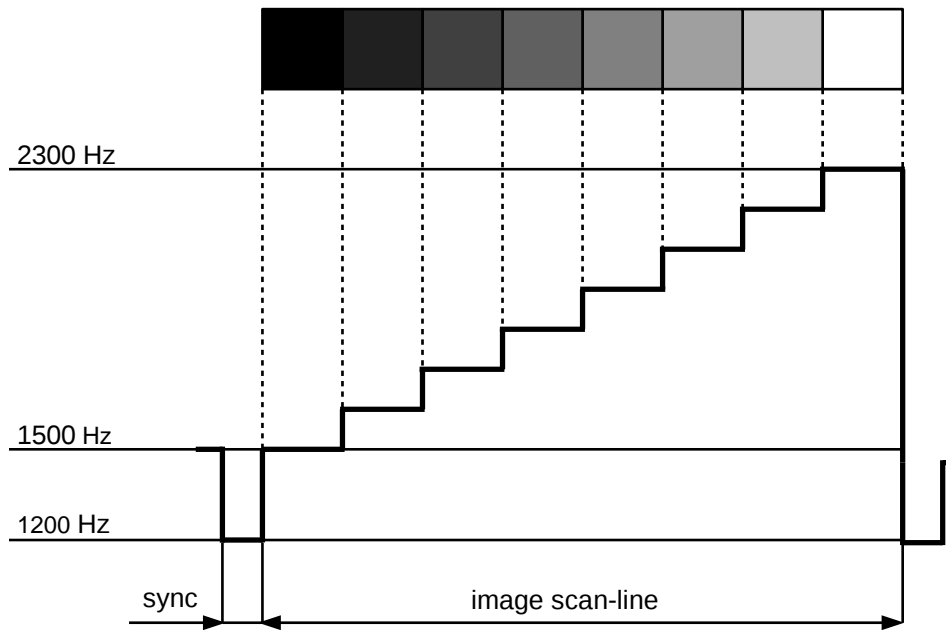

Figure 3.5: The scan line of BW image.

perception considers the green light the brightest. Red and blue are not as bright in our perception.

But a BW television camera only scans the level of intensity, and therefore the resulting image would look like all the colours are the same. They will be characterized by the same gray level depending on their intensity. Due to this fact, a valid gray scale image Y created from basic colour components R , G and B (red, green and blue) is defined as:

$$Y = 0.30R + 0.59G + 0.11B$$

Note that the biggest factor 0.59 is just for the green, so nearly 60% of colours that we can see depends on the green component and only 40% is of the remaining colour components! This is used for simplicity in colour scan converters for BW images. In past years, BW images were not transmitted as true grayscale images, but the brightness signal was derived from the green component of the image. The difference in brightness between a true BW image and the green component of the same image is insignificant in most cases.

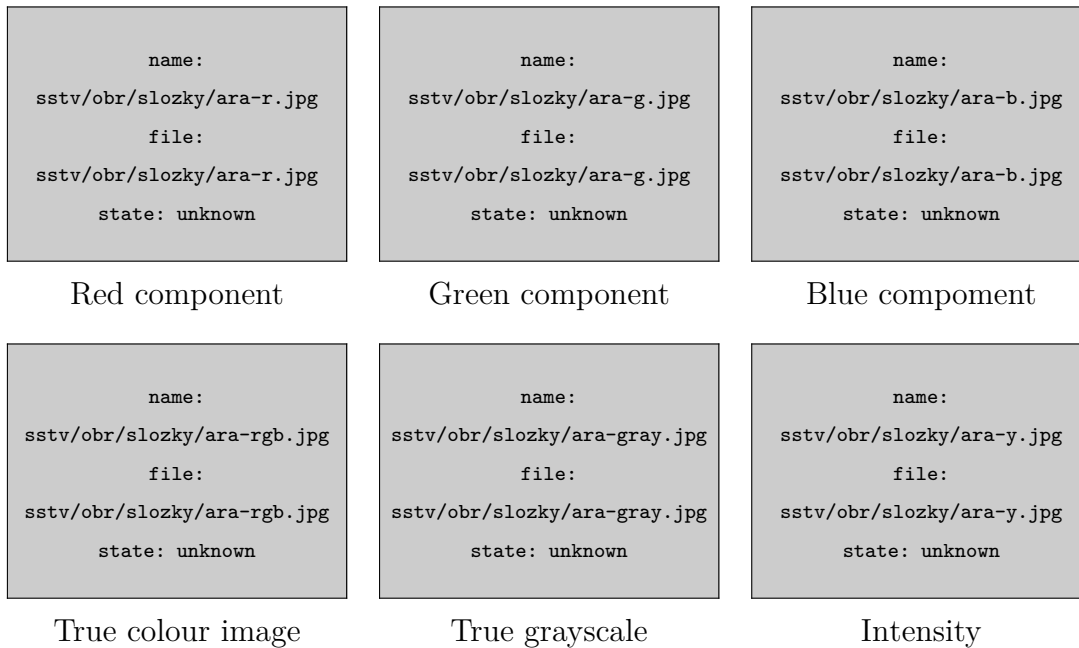

Figure 3.6: Decomposition of colour image to basic components.

3.5 Colour transmission

3.5.1 Additive colour model

Every colour can be decomposed into three primary colours – red, green and blue. The additive colour model produces other colours by combining these three primary colours.

During image transmission, the image is decomposed into these independent colour components on the transmitting side. Then they are gradually transferred, and on the receiving side the components are re-composed into a colour image.

If it is possible to detect about 64 frequency levels in the 800 Hz video channel, then each colour component contains 64 brightness levels. And the resulting colour image then contains $64 \times 64 \times 64 = 256144$ colours. If a demodulator can distinguish 256 levels, it is possible to transfer over 16 millions = 256^3 colours. Colour SSTV transmission can meet the most demanding requirements of colour depth.

Some colour SSTV systems also use a property of human vision, which is a different sensitivity to the primary colour components. In this case; the image scan-lines are not divided into three equal parts for each colour component. Because the eye is most sensitive to green, the largest part of the line takes just this part and the remainder are filled with red and blue parts. For example, the ratio is 4:2:2 for $G : R : B$.

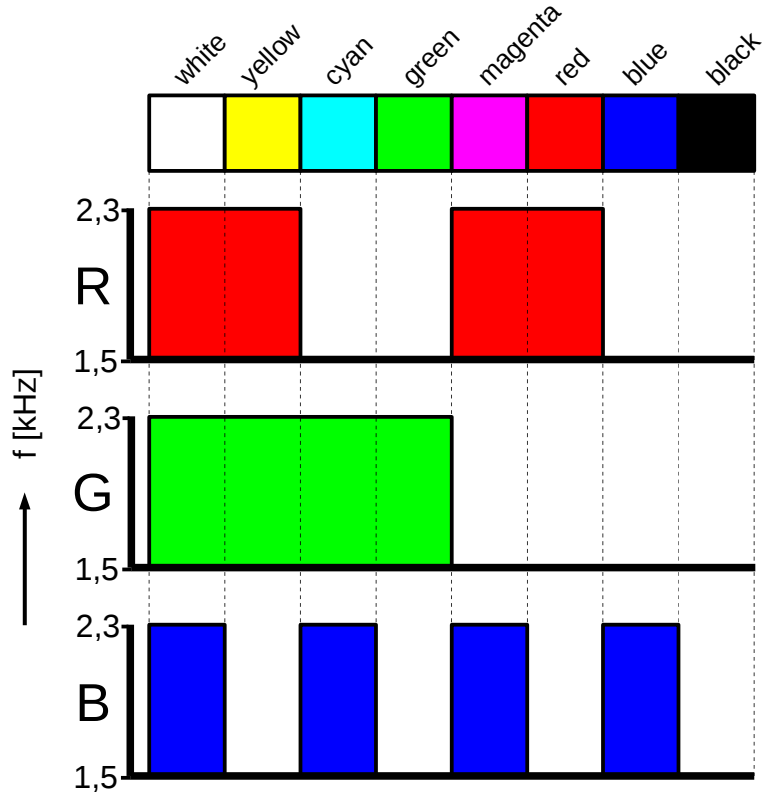

Figure 3.7: Decomposition of colour image into RGB signals.

The additive colour model is a method of transmission that take more time to transmit, but it provides a transfer of true colours.

3.5.2 Composite colour model

The second type of colour transmission is called $YCrCb$. In fact it is a similar system as is used in colour fast-scan television, where each colour component R , G and B , are transformed to *luminance* and *chrominance* (colour information) signals. Unlike RGB, the transmission time of an image is shorter. This colour coding is used for BW and colour compatibility in television broadcasts. In which colour broadcasts can also be received by a BW television.

The image scan-line contains colours transformed into two components – luminance and chrominance. The chrominance signal is composed of two differential colour signals $R-Y$ and $B-Y$. Signal Y is called *luminance* and contains the signal

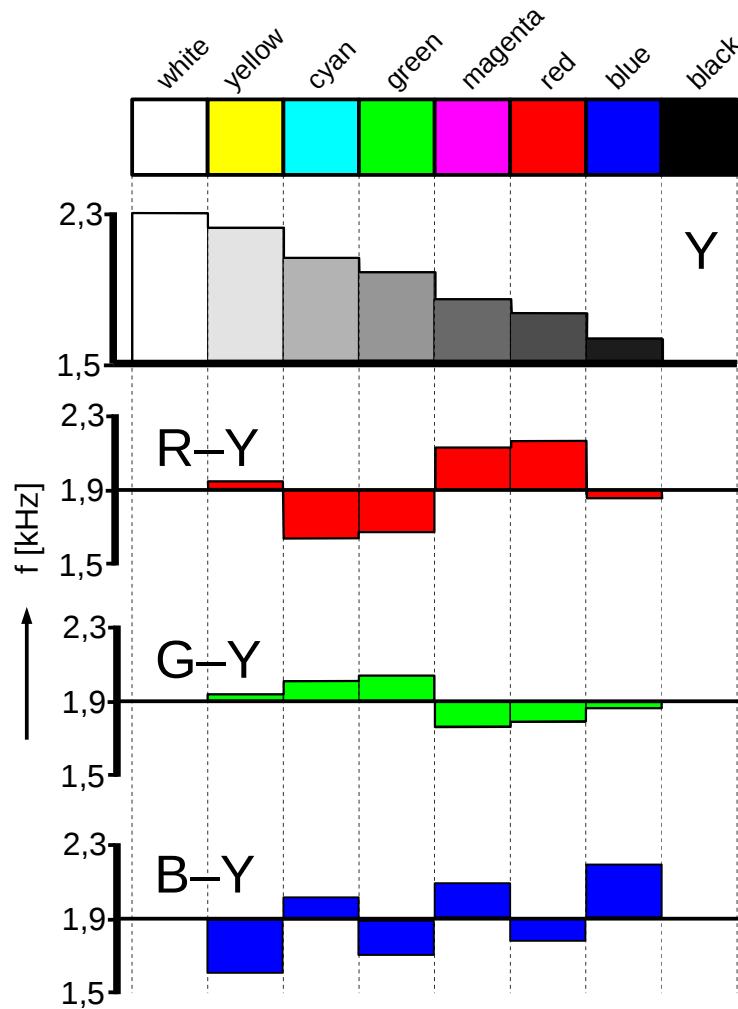

Figure 3.8: Decomposition of colour image into YCrCb signals.

corresponding to brightness produced by the equation $Y = 0.30R + 0.59G + 0.10B$. The Y is for chrominance signals subtracted from the red and blue components.

On the receiving side, the individual colour components are restored: $R = (R - Y) + Y$ and $B = (B - Y) + Y$.

We need a third green component the G , which is derived from $R - Y$ and $B - Y$ from the expression $G = Y - 0.51(R - Y) - 0.19(B - Y)$. Hereby we get complete colour signals.

There are two formats of YCrCb colour transmission used in SSTV. The first format 4:2:2 transmits both chrominance signals (within half the time in comparison with Y) in one line. The second format 4:2:0 contains only one chroma signal. Odd scan-lines could include for instance $R - Y$, and the even scan-lines could be $B - Y$. The chrominance signal is then given by the average of two consequent scan-lines of the original image.

The advantage of this type of transfer to RGB is significantly shorter transmission time. In comparison to RGB transmission, YCrCb takes approximately half the time yet guarantees almost the same image quality.

Its disadvantage compared with the RGB model, is a loss of image information which is higher when the 4:2:0 format is used. Also, precise transceiver tuning is needed, otherwise the colour information will be distorted. This is the reason why the YCrCb encoding is used less frequently. According to the positive or negative deviation from the carrier, the image is strongly hued to pink or green, see **figure 3.9**.



Figure 3.9: Color distortion of YCrCb when the station is improperly tuned.

The transmission for colour FSTV uses YCrCb and also uses special methods and modulation (in PAL, SECAM) to eliminate this colour distortion, which can occur on the transmission path. Unfortunately, this feature does not exist in SSTV and so the result of selective fading¹ can cause colour ghosts in image.

SSTV systems using YCrCb transmission are less resistant to interference than their RGB counterparts, see **fig. 3.10**.

The RGB model is distorted by a low contrast or increased brightness when there is significant deviation ± 200 Hz from the transmitter carrier and thus provides better colours than YCrCb.

¹ *Selective fading* is a phenomenon, where the signal comes from two paths, in which one signal path is the variable and causes instability of the ionosphere layers. It can be often seen in the 80 m band in the morning and evening.



Figure 3.10: Color distortion of RGB when the station is improperly tuned.

3.6 Synchronization

3.6.1 Horizontal synchronization

There are two types of synchronization – *synchronous* and *asynchronous*.

Older SSTV systems use asynchronous transmission. This means that each information frame, in our case a scan-line, will be received after the detection of horizontal sync.

This system detects vertical (image) and horizontal (scan-line) syncs and only after proper detection will it display the received lines. Asynchronous transmission has a huge disadvantage. When interference happens close to the 1200 Hz frequency, an SSTV device can lose several scan-lines if interference remains.

In this respect, all new SSTV systems are improved and use synchronous transmission. These systems use *free-run* scan. It is not necessary to receive vertical sync and it is possible to begin reception from any scan-line. After initial synchronization, it is not required to detect horizontal sync. Thanks to this, synchronous systems are much more resistant to interference. Scan-line sync are still transmitted and then reception could start any time during transmission.

The disadvantage of free-run scan is in complying to the very precise line speed of the corresponding parties. The line speed must be **absolutely** same. If the values are different, there is an unpleasant effect on the picture – slant. For more information on this subject see [section 7.3](#).

3.6.2 Vertical synchronization — VIS code

Vertical synchronization is used to detect the start of transmission. The receiving device can automatically begin the image scan after vertical sync.

The Robot Research company developed a new form of vertical synchronization called *Vertical Interval Signaling* – VIS. All modern SSTV systems adopted the VIS and use these longer syncs and digital headers for automatic SSTV mode recognition.

The VIS contains digital code, the first and last bits are the start and stop bits with 1200 Hz frequency. The remaining 8 bits provide mode identification and contain one *parity bit*. Each bit is transmitted in order from the least significant bit.

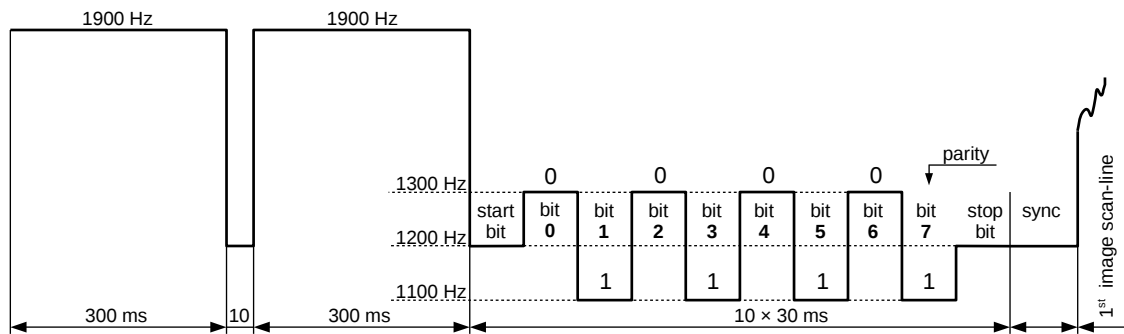

Figure 3.11: Structure of VIS with value 42.

Parity is used for simple error checking. SSTV use even parity. This means, that the number of logical ones must be even in the whole 8bit code. If the number of ones in 7 bits is odd, then the parity bit is set to one. If the number is even, the parity bit is zero. Since the information part of code has 7 bits, it takes 128 values.

Each bit is 30 ms long, so the modulation speed is 33.3 bauds. The frequency 1300 Hz means the state of logical zero and 1100 Hz logical one. The first half of code (least significant bits, LSB) specifies the type of mode (BW/colour, resolution). The second half (most significant bits, MSB) contains information about the system (Robot, Martin, AVT,...). The last bit is reserved for parity error checking.

The meaning of bits **table 3.1** is valid for a system based on Robot Research standard. As the number of new modes have expanded, the bit combination has no additional meaning.

The comprehensive table of all VIS code is on **page 53**.

There is a vertical synchronization in **fig. 3.12** with a value of 10101100_2 (44 decimal). The parity bit is 1, and first three bits 010 distinguish the Martin system. The vertical and horizontal resolution can be determined from the value of the second nibble – 1 256 lines and 1 320 columns, the last two bits with value 00 mean colour transmission.

3.6.3 Additional synchronization data

Some SSTV software append a signal with additional data to the synchronization, e.g. call sign identification, which can then be decoded and used as an input for an

MSB				LSB				Meaning
P	6	5	4	3	2	1	0	
						0	0	Color composite video
						0	1	BW, red component
						1	0	BW, green component
						1	1	BW, blue component
					0			Horiz. resolution 128 / 160 pixels
					1			Horiz. resolution 256 / 320 pixels
				0				Vertical resolution 128 / 120 lines
				1				Vertical resolution 256 / 240 lines
	0	0	0					Robot
	0	0	1					Wraase SC-1
	0	1	0					Scottie, Wraase SC-2
	0	1	1					Scottie, Wraase SC-2
	1	0	0					AVT, Scottie DX
	1	0	1					AVT, PD
	1	1	0					PD
	1	1	1					Pasokon TV
X								Parity bit

Table 3.1: The meaning of bits in VIS code.

electronic station log. Unfortunately these additional signals have no standardized format and they are not compatible with other SSTV programs.

Some of them append the data transmission to the first scan-line image (ChromaPix) or even prior to broadcast of VIS (WinPix, MMSSTV).

Some newly developed SSTV systems do not use standard VIS code with 8 bits and send 16 bits (MP, MR, ML modes) or use odd parity for error checking. This is because of 2^7 , from which 128 possible combinations of the VIS code is almost exhausted. Differences in these and other systems will be described in further chapters.

Mode	decimal	hexa.	binary
Martin M1	44	0x2C	0101100
Martin M2	40	0x28	0101000
Robot 36 colour	8	0x08	0001000
Robot 72 colour	12	0x0C	0001100
Scottie S1	60	0x3C	0111100
Scottie S2	56	0x38	0111000
Scottie DX	76	0x4C	1001100
Wraase SC-2 180	55	0x37	0110111

Table 3.2: The VIS codes of popular modes.

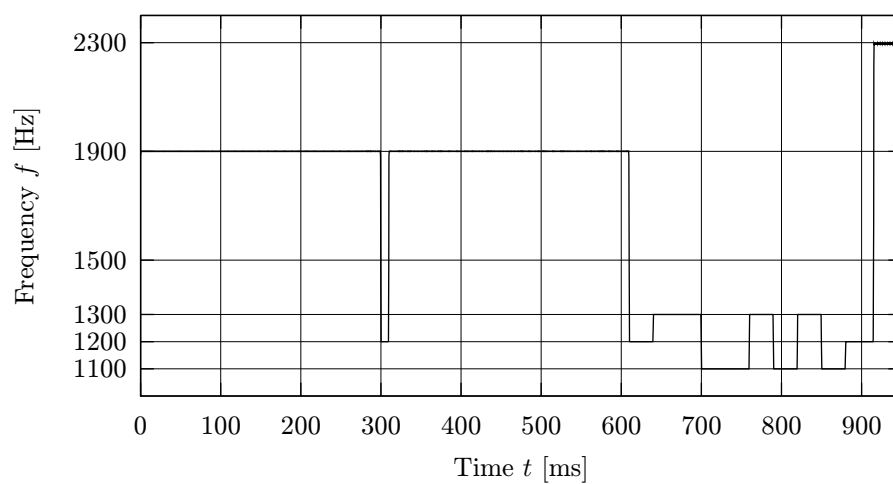

Figure 3.12: The vertical synchronization of Martin M1, the VIS code value is 44.

Formats of slow-scan TV transmission

4.1 Black and white SSTV systems

The earlier modes of SSTV transmission were displayed on long persistent monitors with radar CRT. The duration of transmission for each image frame took 7.2 to 8 seconds, and when the last line was received the first line was still visible. It was possible to see the whole picture in a darkened room.

Both 7.2s and 8s modes were used in the same period. The 7.2s frame speed mode, was used in Europe while the 8s were used in America. The synchronization of signals is derived from the electrical mains – 50 or 60 Hz. If an image was synchronized at 60 Hz and received on 50 Hz equipment, it was still readable, but the image was a little distorted. For long distance QSOs, it was possible to change the oscillator to achieve European or American synchronization.

The disadvantages of 8s SSTV are low image resolution and a loss of synchronization due to signal interference. The loss of synchronization could lead to the loss of a few lines or the whole image.

The differences between modern SSTV modes and this old system are many, but one parameter remains the same. Almost all new systems use 1200 Hz frequency for sync pulses and the frequency band from 1500 Hz (black) to 2300 Hz (white) for video signals. Also the old 8s mode is still supported by many SSTV programs for transmission. It is important to note that 8s mode has the shortest transfer time and should be used in special conditions.

4.1.1 Modes for digital converters

There are many modes for B&W image transmission which differ in transfer time and resolution. Modes Wraase and Robot are implemented in modern converters. The transfer was extended to 256 lines and also transmission time was prolonged to achieve better horizontal resolution.

Commonly used modes were: the 16 second mode with 128 lines, 32 second mode with 256 lines and the 64 second mode with 256 lines which provides maximal image

quality. All these modes are related to the original 8s mode and also have image aspect ratio 1:1. The number of lines, columns or both were simply multiplied twice. This design was used in Wraase B&W converters.

While Wraase modes were derived from the European 7.2s mode, the Robot Research developed an original system for their converters. Robot modes aren't simply derived by "doubling" parameters but their parameters are derived from line speed. The American 60 Hz/8s norm has a transfer speed of 900,0 lpm. The line speeds for new modes were chosen at 600,0 lpm for 12s mode with 120 lines and for 24s mode with 240 lines. The mode with the best resolution has a line speed of 400,0 lpm and a total transmission time of 36 seconds.

The Robot SSTV system reserves the first 16 or 8 lines (for a 240 or 120 line image) for gradation gray scale. The scale can be used to tune the signal more precisely.

Although Robot Research cooperated with Copthorn MacDonald, they ignored the trend in amateur construction of digital converters with doubled modes. Despite this fact, Robot system and its converter *Robot 300* became quite popular even with a price tag of over \$800 in the mid-seventies.

During the 70's and 80's, the ham radio market was not the only outlet for SSTV converters, but the companies found opportunities in the telecommunication market and sold SSTV monitors and cameras as devices for image transmission over telephone lines.

4.1.2 BW transmission with computer software

An example of B&W mode implemented with computers is the AVT 125 BW mode of the *Amiga Video Transceiver* system and it is suitable for good quality image transfer in circa 2 minutes. The mode has a vertical resolution of 200 lines because the Amiga computer resolution was 320×200. The AVT system is different from the previous B&W modes because it has no line sync like WEFAX. The transmission is based on a fully synchronous communication and the exact timing of corresponding stations. This special feature is described in more detail in **chapter 4.2.5** about color AVT modes.

There is also the FAX480 mode for high resolution transmission, with 512×480 image resolution described further in **chapter 4.3.1**.

Early B&W modes Wraase and Robot, need to be synchronized with both line and vertical synchronization. The line speed describes the free-run speed, but in reality it can be deviated up to $\pm 5\%$.

Modern modes like FAX480 and AVT 125 BW need accurate precision of line speed, because just a little deviation of values in tenths causes image slant and distortion.

Mode	Resolution	Aspect ratio	Sync. (ms)	Scan line (ms)	Line speed (lpm)
7.2s (50 Hz)	120×120	1:1	5.0	55.0	1000.0
8s (60 Hz)	120×120	1:1	5.0	60.0	900.0
Wraase SC-1 8	128×128	1:1	5.0	55.0	1000.0
Wraase SC-1 16	256×128	1:1	5.0	115.0	500.0
Wraase SC-1 16 Q	128×256	1:1	5.0	55.0	1000.0
Wraase SC-1 32	256×256	1:1	5.0	115.0	500.0
64s mode	256×256	1:1	5.0	115.0	250.0
Robot B&W 8	160×120	4:3	10.0	56.0	900.0
Robot B&W 12	160×120	4:3	7.0	93.0	600.0
Robot B&W 24	320×240	4:3	12.0	93.0	300.0
Robot B&W 36	320×240	4:3	12.0	138.0	200.0
AVT 125	320×400	4:3	—	312.5	192.000
FAX 480	512×480	1:1	5.12	262.144	224.497
SP-17 BW	128×256	4:3	5.0	62.0	895.520

Table 4.1: Parameters of black and white SSTV modes.

The advantage of longer transmission is improved image quality. The disadvantage, is that a lot of time is needed for the transfer, which could be better utilized for the transmission of color images.

4.2 Color SSTV modes

You might find it incredible that the first color transfer was made before the era of digital converters using long persistence monitors. Each color image channel was obtained using color filters, which were subsequently held in front of the camera. A sample result could be that the first channel transferred was blue, then green and the last red. Slightly more difficult was the processing on the receiver side. This was because each color channel had to be photographed from the monitor screen and then the resultant color picture was combined from all three components. It was a very laborious process, but it was put into practice a few times!

Further experiments with color SSTV transmission were based on frame sequential transfer. Three complete images were transferred in 8s mode and each contained one color channel, together they formed one color image. During broadcast, a color

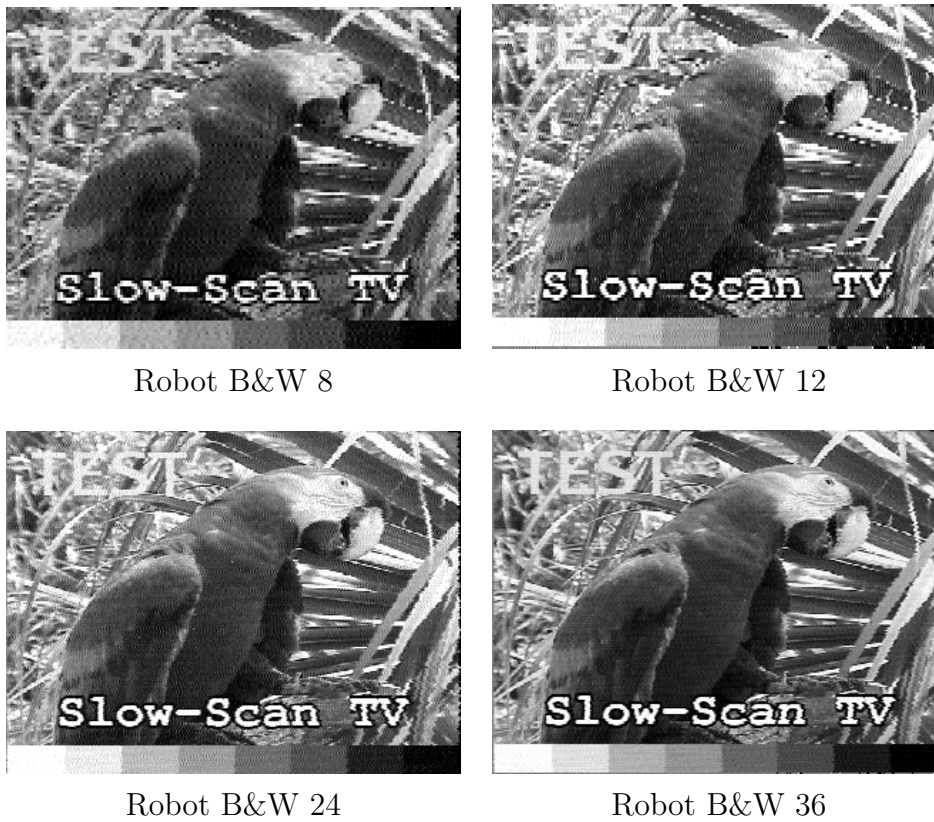

Figure 4.1: Comparison of Robot system's BW modes.

original was progressively scanned with a BW camera through each of the color filters. Received images had to be stored in a digital converter in three different memories. When simultaneously displayed on a color monitor they created a full color image. This is the reason why BW modes of Robot and Wraase families have three different VIS codes for BW transfer. The codes are sent for adjustment of color components for frame-sequential transmission. Individual images were usually sent in the order of red – green – blue. But the order of the channels could be changed under the agreement of corresponding stations, or some images could be broadcast repeatedly. With such a method, it is possible to transfer only static scenes. If an object moves during manual scanning of an image, the color components do not correspond and the result image has colored ghosts.

The transfer was not always reliable; due to interference and fade-outs, the image component had to be sent several times. And in practice, it was sometimes problematic to complete all color channels. To improve color transmission the *line sequential* transfer was developed. The principle is that it transmits a single image

and each scan-line carries all three color components. A receiving equipment can already display color images during transmission. This method where the color image is transferred in one frame is referred to as *SFC – Single Frame color*.

More properties of SSTV systems will be introduced in following sections, with all their pros and cons and details of mode formats described in detail.

4.2.1 Wraase SC-1

This line sequential system was first among newly developed SFC systems. Wraase SC-1 comes from the workshop of famous SSTV engineer Volker Wraase, DL2RZ. The system was most likely created by modifying existing equipment to operate in 8s mode or for frame-sequential transmission.

Each scan-line begins with 6.0ms sync, then a green component follows and then the blue and red components. A separate sync of 6.0 ms length precedes each colour component.

Wraase SC-1 has a major deficiency. If the receiver loses sync during interference, then the display system loses the ability to synchronize colors. Because all lines are sent in the same way, the color components cannot be recognized and the probability that the system reverts back to correct color sync is equal to one-third. In practice the system works, but when the noise level is too high, the received image contains few color bands as the converter loses and restores synchronization. For this reason, an additional sync pulse was added to subsequent productions of the SC-1 converter. It consists of a truncated 5ms sync before the red line, which is immediately followed by a short pulse of 2300 Hz frequency lasting 1-2 ms. It allows the converter to regain synchronization after the noise subsides. Additional synchronization occurs as a thin red stripe in the left edge of the image.

All SC-1 modes have an image aspect ratio of 1 : 1. The original SC-1 mode is the 24s mode with 128 lines, so the image quality is not better than the 8s mode, but the colors improve the picture.

The system was soon upgraded for modes with longer transmission. First, the number of lines was doubled to 256 and the transfer extended to 48 seconds. The last SC-1 96s mode has better horizontal resolution for good image quality.

The professional converter Wraase Electronics SC-1 was most popular in Germany, but its market share was lower in comparison to the Robot converters produced in the same period.

4.2.2 Robot color system

The *Robot* modes are named according to the converters in which they were implemented. They are scan-converters Robot 400C, 450C and 1200C. They were produced in San Diego by Robot Research Inc.

Mode name	Transfer time	Resolution	Color sequence	Scan line (ms)				Speed (lpm)
				Sync	G	B	R	
Wraase SC-1 24 Color	24 s	128×128	G–B–R	6.0	54.0	54.0	54.0	333.3
Wraase SC-1 48Q Color	48 s	256×128	G–B–R	6.0	108.0	108.0	108.0	175.4
Wraase SC-1 48 Color	48 s	128×256	G–B–R	6.0	54.0	54.0	54.0	333.3
Wraase SC-1 96 Color	96 s	256×256	G–B–R	6.0	108.0	108.0	108.0	175.4

Table 4.2: The Wraase SC-1 scan-line timing.

They do not use RGB color coding as SC-1, but YCrCb. Scan-lines consist of a luminance signal Y followed by differential chrominance signals $R - Y$ and $B - Y$. Due to this, the color modes are compatible with their B&W variants. So a 12s color mode can be displayed by 8s monitors, etc.

From a total of 8 modes 4 are intended for color transmission. Half of the color modes use YCrCb in a 4:2:0 format. The scan-line contains only one chrominance signal, and colors are obtained from the average of two adjacent lines in the original image. The other two modes use the 4:2:2 format and send all color information in one scan-line.

The original Robot system uses asynchronous transfer. To receive the image, it is needed to detect the vertical sync (VIS code). And for proper reception of the image, the sync pulse must be detected. This process is a major disadvantage.

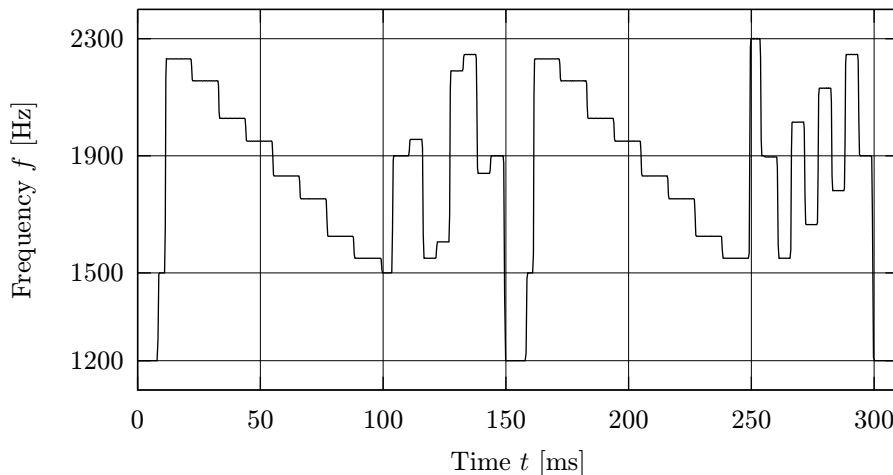

Figure 4.2: Two scan-lines of Robot 36 Color when color bars are sent.

The scan-line is composed of the starting sync, followed by a short 3.0ms gap of 1500 Hz and then the image part with luminance and chrominance. The chrominance

differential signals begin with additional sync pulses. The 1500Hz sync is before $R - Y$ and the second 2300Hz is before $B - Y$. Due to the additional sync with a different sync frequency, it is possible to re-synchronize 4:2:0 formats after an interruption. The chrominance syncs are separated from the scan-line with 1500Hz gap that lasts 1.5 ms.

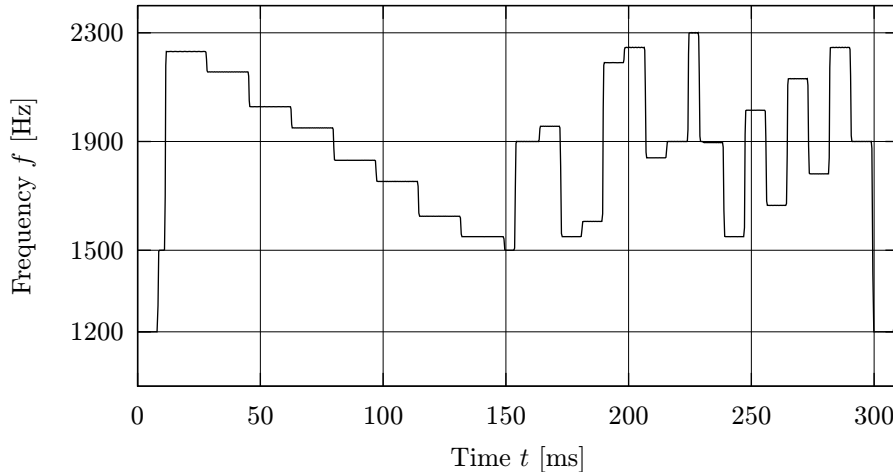

Figure 4.3: The scan-line of Robot 72 Color when the color bars are sent.

The main disadvantage of the Robot modes lies in color coding, because the receiver must be perfectly tuned to the SSTV signal. Otherwise the image hue is distorted when the deviation is greater than ± 50 Hz. For this reason, Robot Research introduced the transmission of gray gradation scale at the beginning of image transfer and the receiver device can auto-tune for video signal.

The whole frame has 256 or 128 lines, of which the first 16 or 8 lines are reserved just for gradation scale. Some converters and PC software add some basic station info, such as call sign, and this part of the frame is called “header”.

The memory storage capacity of the Robot 1200C converter allows it to store an image with a resolution 256×240 pixels or four images with 128×120 , and they are displayed in a 4:3 aspect ratio.

The fastest mode of the Robot family and the fastest color SSTV mode is the 12s mode. It contains 120 lines transmitted in the 4:2:0 format. Another mode is 24s with a 256×120 resolution and 4:2:2 color format. The other two modes allow the transfer of images in 256×240 resolution, either in less quality for 36 seconds in a 4:2:0 format or in better quality in 4:2:2 format for 72 seconds.

Although the Robot modes were pushed away by modern synchronous modes that are more resistant to interference, the 24s and 36s modes are faster than modes with RGB color coding, and have better resolution than RGB modes with the same



Figure 4.4: Comparison of Robot color modes.

transmission time. You can find their benefits on VHF with FM transmission, because it eliminates the need for precise tuning.

Robot 36 Color was used in MAREX², SAREX³ and ARISS⁴ programmes for SSTV transmission from orbital stations Mir, ISS and space shuttle missions. It is a pretty good compromise between image quality and transfer time, because space stations on low earth orbit can be received within just 10 minutes during their orbit.

4.2.3 The Martin synchronous system

The creator of this popular system is Martin Emmerson, G3OQD. He originally named it “New Modes”, but to avoid confusion between other newly emerging SSTV modes, the community universally named modes after their creators. The Martin was created to overcome SFC problems in systems like SC-1 due to two main changes.

² Mir Amateur Radio Experiment
³ Shuttle Amateur Radio Experiment
⁴ Amateur Radio on the International Space Station

Mode name	Transfer time	Resolution	Color format	Compatible B&W mode
Robot 12 Color	12 s	160×120	4:2:0	Robot B&W 8
Robot 24 Color	24 s	320×120	4:2:2	Robot B&W 12
Robot 36 Color	36 s	320×240	4:2:0	Robot B&W 24
Robot 72 Color	72 s	320×240	4:2:2	Robot B&W 36

Mode name	Color sequence	Sync pulses of			Scan-line			Speed (lpm)
		line	color	color	Y	R-Y	B-Y	
Robot 12 Color	YCrCb	7.0	3.0	—	60	30		600.0
Robot 24 Color	YCrCb	12.0	6.0	6.0	88	44	44	300.0
Robot 36 Color	YCrCb	10.5	4.5	—	90	45		400.0
Robot 72 Color	YCrCb	12.0	6.0	6.0	138	69	69	200.0

Table 4.3: The Robot parameters and scan-line timing.

The first change was that instead of three separate syncs before each color component, there is just a single sync sent before each scan-line. The horizontal sync lasts 4.862 ms. After the horizontal sync, the green component is sent, then blue and last is the red component. Between each color components, there are short gaps of 1500 Hz lasting 0.572 ms. Just like in the SC-1, the sequence green – blue – red was chosen. Regardless of the order in which components are sent, the image quality will not change. But it is important that the receiving device identifies which component it is currently receiving.

An important feature of using only one sync before beginning the color scan-line sequence, is that a converter will not replace the individual color components and degrade the color information. In time intervals where the line sync is not transmitted, the gaps are filled with a reference level of black at 1500 Hz for 0.572 ms.

The second improvement has a substantial effect on image reception. Unlike the Robot or SC-1, the detection of horizontal syncs is not necessary during reception. And the broadcast between stations is fully synchronized. The results of the use of such a system are sharper images and more contrasted edges. Although the transmission conditions on the lower HF bands often do not allow the transfer of the image in 100% quality, old systems relying on line sync usually lose synchronization in such conditions.

The Martin system was originally implemented as a modification of the Robot 1200C converter and it preserves the transmission of the header gradation scale.

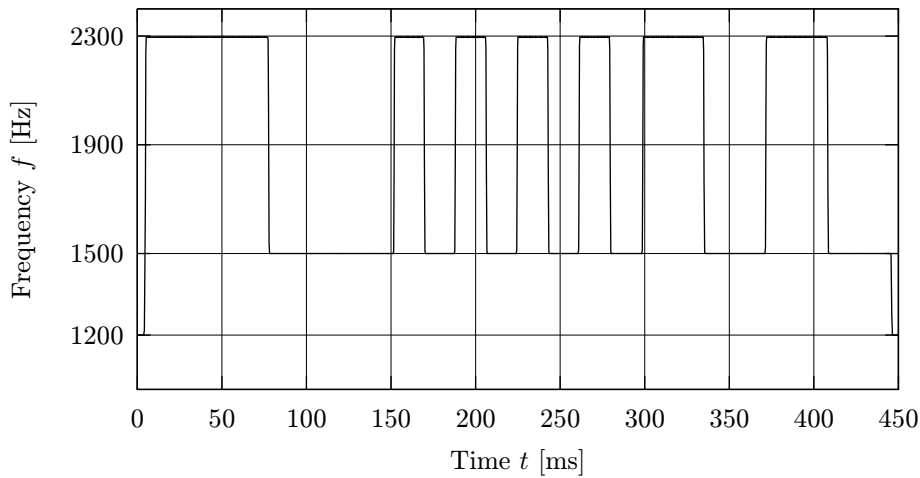

Figure 4.5: Scan-line of Martin M1 when color bars are sent.



Robot 36s Color

Martin M1

Figure 4.6: A comparison of systems in real conditions on the 3.7MHz band.

Line syncs and inner scan-line gaps have a similar duration at all four speeds, but the number of lines and horizontal resolution for each mode is different. Although the syncs aren't necessary for transmission, they are still transmitted at the beginning of each scan-line in order to synchronize the converter at any time during the reception. It is important because it consumes a lot of broadcast time and the station does not have to wait for the start of a new frame, but a receiver can get synchronization at any time during transmission.

The Martin system allows us to work with four different modes/speeds. The most popular version is the Martin M1 with 256 lines per frame in two minutes. Other modes of the Martin system have either half the line or half the horizontal resolution of the best quality M1. The mode M4 has the lowest quality and 128 lines. Modes Martin M1 and M2 are often used between European stations.

Mode name	Transfer time	Resolution	Color sequence	Scan line (ms)				Speed (lpm)
				Sync	G	B	R	
Martin M1	114 s	320×256	G–B–R	4.862	146.432	146.432	146.432	134.3947532
Martin M2	58 s	160×256	G–B–R	4.862	73.216	73.216	73.216	264.5525975
Martin M3	57 s	320×128	G–B–R	4.862	146.432	146.432	146.432	134.3947532
Martin M4	29 s	160×128	G–B–R	4.862	73.216	73.216	73.216	264.5525975

Table 4.4: The Martin scan-line timing.

4.2.4 Scottie

These modes were created by Eddie T. J. Murphy, GM3SBC. He modified the original firmware of Wraase SC-1. Martin Emmerson also implemented Scottie modes to Robot 1200C later on.

Scottie has the same improvements as the Martin system does, but its scan-line composition and scan timing are different.

After vertical synchronization, the sequence of scan-lines is; a 1.5ms short gap of 1500 Hz, then a green component, a 1.5ms short gap again, a blue component, then a horizontal sync, another gap and lastly, a red component. This unusual order is the result of the system adaptation to SC-1, where the additional sync was used right before the red component. Syncs are permanently sent for any time synchronization during reception.

The Scottie relies on exact timing like the Martin, although the original version for SC-1 was not fully synchronous and syncs were still processed by the converter. But in newer systems the modes are implemented for free-run reception, so the system is equivalent to the Martin.

The implementation of Scottie in Robot 1200C slightly differs, because the first scan-line includes an additional 9.0ms sync at the beginning of the scan-line right after vertical synchronization. All other modes implemented in Robot 1200C have sync at the beginning of the scan-line but the Scottie has the sync in the middle of the scan-line which then caused color distortion. Perhaps some other implementation of Scottie has this difference too.

The Scottie system also has four conventional modes (and a special one described later). Two with 256 lines per frame and two with 128 lines. The difference in timing is not the same as in the Martin, where the line speed of the faster mode is exactly twice the speed of the slower mode, so the speed of the faster mode is lower than twice that of the slower mode.

Image quality in the Scottie and Martin modes is the same. Theoretically, a slightly better quality can be achieved in Martin M1 than in Scottie S1 due to longer transmission, but the difference is imperceptible.

The Scottie S1 and S2 are quite popular for North American stations and can often be heard on high frequency bands.

4.2.4.1 Scottie DX – special mode for long distance transfers

This mode of the Scottie family achieves the best possible results in the transmission of slow-scan television images. There is one simple reason for this; the transmission takes about 2.5 times longer than Scottie S1.

There is an extended duration of the scan-line, but the duration of sync and gaps between color components remained the same. This improvement is best seen on the receiving side. The longer transmission time supports better image quality.

The improvement relies on the fact that; each pixel can be read more times during signal sampling and that the loss of a few samples does not affect overall quality. It means that each pixel takes a long time and this gives better noise and phase distortion immunity. But these qualities are compensated by a very long image transmission time of about 4.5 minutes. During this time, two images with the same resolution can be sent with other RGB modes.

The Scottie DX mode offers high quality images, but sometimes the optimal conditions for DX connections do not last long enough for the transfer of a whole picture.

Mode name	Transfer time	Resolution	Color sequence	Scan line (ms)			Speed (lpm)	
				Sync	G	B		R
Scottie S1	110 s	320×256	G–B–R	9.0	138.240	138.240	138.240	140.1148942
Scottie S2	71 s	160×256	G–B–R	9.0	88.064	88.064	88.064	216.0667214
Scottie S3	55 s	320×128	G–B–R	9.0	138.240	138.240	138.240	140.1148942
Scottie S4	36 s	160×128	G–B–R	9.0	88.064	88.064	88.064	216.0667214
Scottie DX	269 s	320×256	G–B–R	9.0	345.600	345.600	345.600	57.12653528

Table 4.5: The Scottie scan-line timing.

4.2.5 Amiga Video Transceiver

AVT modes were originally intended for SSTV operations with Amiga computers. AVT author Ben B. Williams, AA7AS developed a dedicated interface and software

which was produced by AEA (Advanced Electronic Applications Inc.). Although the creator claimed that this system was a revolution in SSTV transmission, these modes did not gain popularity like other modes. The AVT modes are practically not in use today.

A reason for this could be the fact that the manufacturer wanted to keep the image scan parameters of the system, secret. However, by intercepting signals and reverse engineering, the parameters of the AVT modes were implemented in other devices by the SSTV community. This was done without the additional software tools that made the AVT unique.

The AVT system contains four line sequential RGB modes and one B&W. The scan-lines have no gaps between color components and a really unusual thing is that; the modes do not use any horizontal sync. Another unusual feature is the mandatory function of vertical synchronization, that is sent as a digital header before the image transfer begins.

The AVT family contains 5 modes and each of them has the following four options:

1. Default variant is the same as conventional SSTV modes, but does not have any line syncs.
2. *Narrowband variant* uses shorter band for video signals from 1700 Hz for black to 2100 Hz for white.
3. *QRM variant*, that uses picture interlacing just like in analog television.
4. The combination of the QRM and narrowband variant.

The fastest mode is the AVT 24 with 120 lines and it is transferred for 31 seconds. The next mode is AVT 90 with a resolution of 256×240 and an image quality slightly worse than in the Martin M1. AVT 90 sends each color component in 125.0 ms, thus the speed is 2048 pixels per second (in binary notation this gives a nice rounded number). The other two modes have somewhat atypical resolutions in comparison with other SSTV modes, but these resolutions are normal system resolutions on Amiga computers. It is AVT 94 with 320×200 and AVT 188 with the same line speed, but twice the scan-lines – 320×400 . The image is displayed in an aspect ratio of 4:3 in both cases.

For some SSTV systems/scan-converters, the detection of vertical sync is a must. So, the VIS code is repeated three times for accurate reception. VIS is necessary for image reception when *no* line sync is sent and later synchronization is not possible. The original AVT software however, does not need to receive VIS, but relies more on the digital header.

After a series of VIS code, there is a digital header (see [fig. 4.7](#)), which contains synchronization data. It is a sequence of 32 frames of 16 bits. Each frame contains only 8 bits of information, but it is sent twice – first in normal form and second inverted. Normal and inverted parts can be compared for error detection. Each

frame starts with a 1900Hz pulse while data modulation uses 1600 Hz for the representation of logical zeros and 2200 Hz for logical ones. Narrow-band variants use 1700 Hz for zeros and 2100 Hz for ones. Both variants use a modulation speed of exactly $2048/20 = 102.4$ Bd, so the data pulse has a length of 9.766 ms.

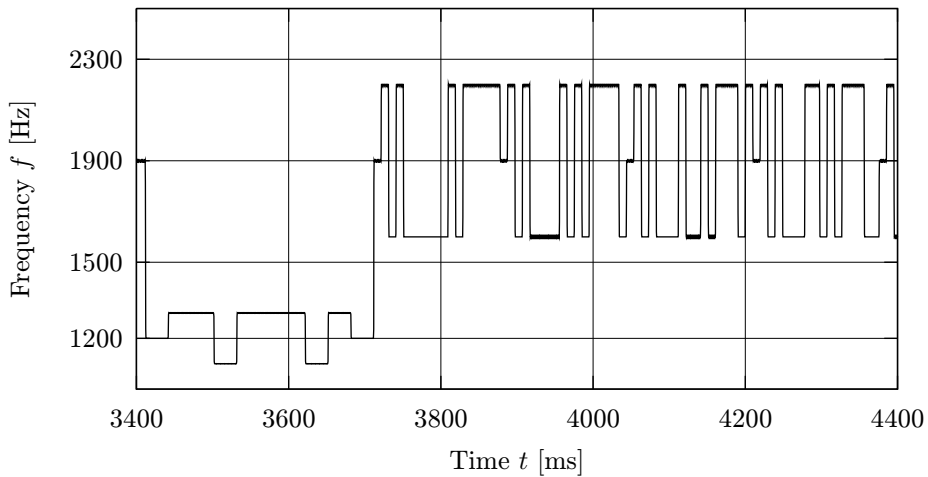

Figure 4.7: The digital synchronization header of AVT 90 mode (VIS 68, normal variant).

The first three bit of each 8bit word identifies the mode:

- ▷ 010 – AVT 24,
- ▷ 011 – AVT 94, AVT 188, AVT 125 BW,
- ▷ 101 – AVT 90.

The last five bits are used as a count down before image transmission. Actually these five bits are important for an accurate set of image initiation and synchronization. They vary between all 32 binary combinations during transmission. At least one binary code must be properly detected. At the beginning, all bits are in 0 states with 1 in inverted parts. When the countdown starts, all five-bit sequences run (e.g. for AVT 24):

```

010 00000 101 11111
010 00001 101 11110
010 00010 101 11101
...
010 11101 101 00010
010 11110 101 00001
010 11111 101 00000
    
```

When the count down gets to zero, the image scan-lines are sent. AVT reception depends on the first eight seconds of synchronization, for some implementations without the ability to synchronize later. Although the AVT modes are quite reliable, noise could cause a loss of the whole image. Sometimes it is not possible to receive a digital header due to interference, even if the interference later disappears. However, the original AVT software was capable of image reconstruction in this case. Because the image data is completely synchronous, the data simply has to be shifted in memory until the RGB data is aligned correctly, and then the image comes out perfectly. Again, the AVT system provided means to hot reconfigure the data after reception. So reception without/after sync header worked fine.

The earlier listed options for each mode can improve its performance. The first is the narrow-band transmission which uses a 400 Hz band from 1700 Hz (black) to 2100 Hz (white). With an appropriate filter, the resistance to interference can be improved with minimal loss of image quality. For instance; the 400 Hz wide CW filter can be used with a variable IF shift.

The second option is the “QRM mode”, where an entire image is sent interlaced. Within the first half of image transmission time, half of the scan lines (every odd one) is sent. Then the scan loops back to the beginning and sends the remaining half lines (even lines). The fact that some of the disturbed lines of the first field is interlaced with fine lines received from the second will definitely improve the overall subjective impression of image quality. The original AVT software also contains tools for handy image improvement – it is possible to select distorted lines and the program will reconstruct them by averaging neighborhood lines. It is also possible to shift the second field horizontally independently of the first field. This allows you to compensate if there is a significant multi-path delay in regard to the two fields.

In ATV implementations, the system can work well without this interactive tools. But in practice, especially on shortwaves where conditions change quickly; the second field could be phase-shifted and this causes the notable “toothy” edge of the picture. The QRM option can be combined with the narrow-band mode.

Mode name	Transfer time	Resolution	Color sequence	Scan line (ms)				Speed (lpm)
				Sync	R	G	B	
AVT 24	31 s	128×120	R–G–B	—	62.5	62.5	62.5	960.000
AVT 90	98 s	256×240	R–G–B	—	125.0	125.0	125.0	480.000
AVT 94	102 s	320×200	R–G–B	—	156.25	156.25	156.25	384.000
AVT 188	196 s	320×400	R–G–B	—	156.25	156.25	156.25	384.000
AVT 125 BW	133 s	320×400	Y	—	312.5			192.000

Table 4.6: The AVT scan-line timing.

4.2.6 Wraase SC-2

A later version of Wraase modes was first built in the newer converter SC-2 from Wraase Electronics. Again, it provides another variant of line sequential systems. The author dropped the sequence of colors used in the earlier SC-1 converter, so the colors are now sent in the order: red – green – blue. Additionally, there is only one horizontal sync at the beginning of each line, just as in the Scottie and Martin.

Unlike other systems, the RGB system in the SC-2 has one characteristic that distinguishes it from other conventional modes. Image transfer is achieved when the transmission time for the green component is equal to the sum of the transmission time of the red and blue components, i.e. the ratio 2 : 4 : 2 of R : G : B components. Between color components short gaps are not sent.

As we already know that the human eye is most sensitive to green by more than 50 %. The remaining 50 % in SC-2 is split evenly between the red and blue components. Red and blue components are not processed for a differential signal. This color reduction is not visible on common pictures, but it may happen that some images (e.g. B&W mosaic) may lose color information. The system is less precise for color interpretation in comparison with YCrCb modes, but better in tuning resistance. One disadvantage of color reduction is found, when green shadows appears on the image in stations without precise clock timing.

This mode is preferable in comparison to YCrCb because bad tuning will only reduce the contrast or saturation, but the hue is not distorted. Occasional green shadows remain as a tax for reduced transmission time.

The Wraase SC-2 family just like all other systems, also has four different modes. The SC-2 180 offers best quality for three minute transmission, and unlike the previous modes does not use the RGB ratio 2 : 4 : 2 and is therefore a faster alternative to the Scottie DX mode. The two-minute SC-2 120 uses the RGB format 2 : 4 : 2. The remaining two modes, SC-2 30 with 128 and SC-2 60 with 256 lines have about half of the resolution found in SC-2 120.

Mode name	Transfer time	Resolution	Color sequence	Scan line (ms)				Speed (lpm)
				Sync	R	G	B	
Wraase SC-2 30	30	256×128	R-G-B	5.0	58.0	117.0	58.0	249.600
Wraase SC-2 60	60	256×256	R-G-B	5.0	58.0	117.0	58.0	249.600
Wraase SC-2 120	120	320×256	R-G-B	5.0	117.0	235.0	117.0	126.175
Wraase SC-2 180	180	512×256	R-G-B	5.0	235.0	235.0	235.0	84.383

Table 4.7: Wraase SC-2 scan-line timing.

4.3 High resolution transmission

High quality images consume a lot of memory but memory was very expensive in early computer systems. High resolution images were a real luxury, but over the years memory has gotten cheaper, therefore modern SSTV systems now have modes for high resolution broadcast too.

4.3.1 FAX480

Synchronous mode was the first high resolution mode. It was first implemented in the ViewPort VGA interface and software for IBM PCs in 1993. The old VGA cards with 256 kB of memory can hold an image with a resolution 640×480 with only 16 colors. This provides only gray scale images, so this mode is used for only B&W transmission.

The image resolution of FAX480 is 512×480 and the transmission time is 138 seconds. In the early days of high resolution transmission, the only way to transmit hi-res images was facsimile (see [chapter 11](#)). So the creator Ralph Taggart, WB8DQT called it FAX480, but compared with classic facsimile there are not many similarities.

The synchronization of the FAX480 is derived from the reference frequency of 4.0 MHz, and a time unit is $4 \text{ MHz} / 2048 = 1953.125 \text{ Hz}$.

Vertical sync is resolved as follows. In the first five seconds a rectangular frequency modulation of 244 Hz between the black (1500 Hz) and white (2300 Hz) levels is transmitted. This creates the APT⁵ signal.

The tone 1500 Hz is transmitted for 4 time units ($4 \times [1/1953.125] = 2.048 \text{ ms}$) and 2300 Hz for 2.048 ms too. This gives a frequency of an ATP tone also 244 Hz ($1/[2.048 + 2.048] = 244 \text{ Hz}$). This sequence is then repeated exactly 1,220×. Originally the system did not use the VIS code, but the code 85 was later added.

Originally, vertical sync is followed by a phasing interval of 20 white lines. Each begins with 5.12 ms sync 1200 Hz (10 time units), but this interval is omitted in some implementations.

Now it's time to transfer the image itself. It is composed of 480 lines. Each line begins, unlike the facsimile, with 1200Hz sync with a length of 5.12 ms and then continues a scan-line with 512 pixels. The duration of the scan-line is $512 \times (1/1953.125) = 262.144 \text{ ms}$.

According to the creator, the horizontal resolution of 512 points was selected just because the FAX480 operating software had a control menu to the left of the screen.

⁵ Automatic Picture Transmission signal, see [section 11.2.1](#) .

4.3.2 Pasokon TV

These synchronous modes were released with *Pasokon TV* interface from John Langer, WB5OSZ. These modes retain essential SSTV parameters. They also used color coding to transmit the individual color components in the order of red – green – blue with the format 1 : 1 : 1.

There are three modes in the Pasokon system. They have different transmission times: 3, 5 or 7 minutes, so the image quality differs.

Each mode has a default timing for scan-lines:

- ▷ Pasokon P3 ...4800 Hz
- ▷ Pasokon P5 ...3200 Hz
- ▷ Pasokon P7 ...2400 Hz

The scan-line starts with a sync of 20 time units, then there is a 5 unit black gap followed by the red component. It has 640 units, so there is one unit for each pixel. There are 5 unit black gaps between color components and at the end of the scan-line before the sync of the next line. These gaps should help improve the detection of syncs.

Pasokon P7 has the best image quality and longest transmission time which takes nearly seven minutes. If we split such an image into four equal parts, the image quality of one of them would correspond to that produced by the Martin M1 or Scottie S1 modes. The upper 16 lines are used for gray scale, and the remaining 480 for your own image.

There are also two other modes with 480+16 lines. The P5 has a transfer time of almost 5 minutes with lower image quality and the P3 runs fastest at three minutes with a horizontal resolution about half of a P7.

A potential disadvantage of these modes is actually quite a long transfer time, which makes it difficult to use on highly variable short-waves. For those who do not mind the long transmission times, it can be used for exchanging pictures on VHF.

Mode name	Transfer time	Resolution	Color sequence	Scan line (ms)				Speed (lpm)
				Sync	R	G	B	
Pasokon P3	203 s	320×496	R–G–B	5.208	133.333	133.333	133.333	146.56488550
Pasokon P5	305 s	640×496	R–G–B	7.813	200.000	200.000	200.000	97.70992366
Pasokon P7	406 s	640×496	R–G–B	10.417	266.667	266.667	266.667	73.28244275

Table 4.8: The Pasokon TV scan-line timing.

4.3.3 PD modes

PD modes are the result of a cooperation between Paul Turner G4IJE and Don Rotier K0HEO. The mode was first introduced in May 1996 and it was developed to improve image quality and especially to reduce transfer times in comparison with Pasokon TV.

For speeding up transmission, YCrCb color coding is used in the 4:2:0 format. If you divide the total time between two syncs by four, the result is the actual time for each color component. The scan-line begins with 20.0ms sync, then there is a 2,080ms gap of black, and the first luminance signal Y_1 . It is followed by chrominance signals $R - Y$ and $B - Y$ without any gap. Then there is a second luminance Y_2 . The exact timing of modes is:

- | | |
|------------------------------|------------------------------|
| ▷ PD-50 – 286 μ s/pixel | ▷ PD-180 – 286 μ s/pixel |
| ▷ PD-90 – 532 μ s/pixel | ▷ PD-240 – 382 μ s/pixel |
| ▷ PD-120 – 190 μ s/pixel | ▷ PD-290 – 286 μ s/pixel |
| ▷ PD-160 – 382 μ s/pixel | |

YCrCb color coding needs accurate signal tuning to prevent color distortion. Thanks to a wide horizontal sync, it is possible to detect frequency deviation and compensate color distortion. There is also gray scale on the top of image for tuning detection.

The main advantage is reduced transmission time compared with RGB modes. The PD-290 mode supports a resolution of 800×600 and its transfer time is nearly five minutes, although at the cost of little color loss. Some modes have resolutions of 640×480, while PD-160 has 512×384. The fastest two-minute PD-120 has a worse image quality, but in many cases it is still sufficient. Beside the five modes with high resolution, the system includes two with standard resolution. PD-90 uses 320×240 and has a better image quality than Martin M1 or Scottie S1, because it is based on a longer transmission time per pixel. The last mode is the very fast PD-50, which provides a similar resolution as Scottie S2.

4.4 Experimental modes

During the years of the SSTV boom many modes were created, but never gained popularity. Many of them are totally forgotten, like WinPix GVA, Proscan J-120, WA7WOD system or ScanMate, although some of them have a few interesting features which we are about to delve into.

Mode name	Transfer time	Resolution	Color sequence	Scan line (ms)				Speed (lpm)
				Sync	$Y_{1,2}$	$R - Y$	$B - Y$	
PD-50	50 s	320×240	Y-C	20.0	91.520	91.520	91.520	309.150866
PD-90	90 s	320×240	Y-C	20.0	170.240	170.240	170.240	170.687301
PD-120	126 s	640×480	Y-C	20.0	121.600	121.600	121.600	235.997483
PD-160	161 s	512×384	Y-C	20.0	195.854	195.854	195.854	149.176545
PD-180	187 s	640×480	Y-C	20.0	183.040	183.040	183.040	159.100552
PD-240	248 s	640×480	Y-C	20.0	244.480	244.480	244.480	120.000000
PD-290	289 s	800×600	Y-C	20.0	228.800	228.800	228.800	128.030044

Table 4.9: The PD modes scan-line timing.

4.4.1 MSCAN TV

The modes TV-1 and TV-2 were one of many experiments in the SSTV transmission field. An interesting feature is the use of *interlaced* transmission. They do not use the same half-frame interlacing like normal television does. But the whole image, is divided into four quarter-frames. These frames are transmitted gradually in the direction from top to bottom, so you can get a first preview of the image after the first quarter of transmission time, but only in low resolution. Thanks to interlacing the resolution increases gradually during transmission up to 320×256.

It is possible to receive these modes with conventional equipment without interlacing support, because their line speed are the same as for Wraase SC-180 (TV-1) and Martin M1 (TV-2) modes. But in this condition, the image will contain four bars with all quarter-frames.

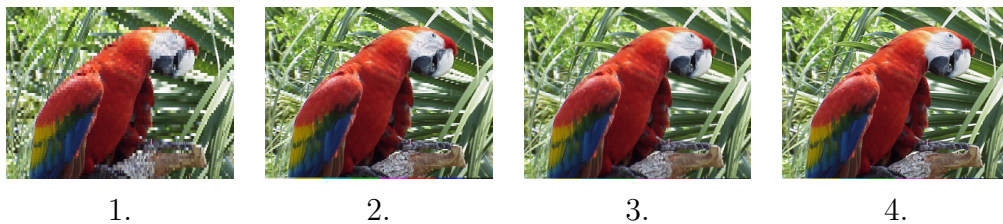

Figure 4.8: MSCAN TV image interlacing.

4.4.2 Kenwood FAST FM

This mode is built in the mobile SSTV converter *Visual Communicator VC-H1* from Kenwood (see [section 6.7](#)). This unit support some normal modes and the “FAST FM” mode.

The FAST FM mode sends video signals in the 2800 Hz (black) to 4400 Hz (white) band. The vertical synchronization and VIS code format is similar to Robot's standard, it has a value of 90, but uses odd parity (the number of logical ones must be odd). After the VIS code there is a digital header and then an image with a resolution of 320×240 .

The duration of one scan-line is 53.6 ms, so the total transmission time for an image is 13.5 seconds. The mode uses YCrCb color coding in the 4:2:0 format. The brightness signal occupies 35.4 ms of scan-line, and then there is a pulse of 3600 Hz that lasts 0.41 ms and then color signals are sent. Each even scan-line contains $R - Y$ and odd line $R - Y$. The scan-line is ended by 0.41 ms pulse again. The transmission of a whole image is ended by one second pulse of 1900 Hz.

Due to fast transmission, the used bandwidth of FAST FM is in 1.0 to 6.2 kHz range, so it cannot be used in the SSB voice channel, but only in FM channels on VHF. The image quality is comparable to the Robot 36 Color mode.

4.4.3 Modes MP, MR, ML

These modes were created by Makoto Mori, JE3HHT, the author of MMSSTV software. Some of these modes became quite popular, because of the success of MMSSTV. The author created modes with both standard and high resolutions. They use YCrCb colors and extended VIS code. Some modes use a narrower band for syncs and video signals.



Martin M1

MP115

Figure 4.9: The comparison of modes in real conditions on the 3.7MHz band.

The change he made to the traditional VIS specification extends the code by 8 extra bits, so a 16-bit code is sent instead. The first 8 bits (LSB) are the same for each mode with a value of 35 (0x23) that identifies the system. While the remaining bits (MSB) distinguish a particular mode. Odd parity is used as a simple check.

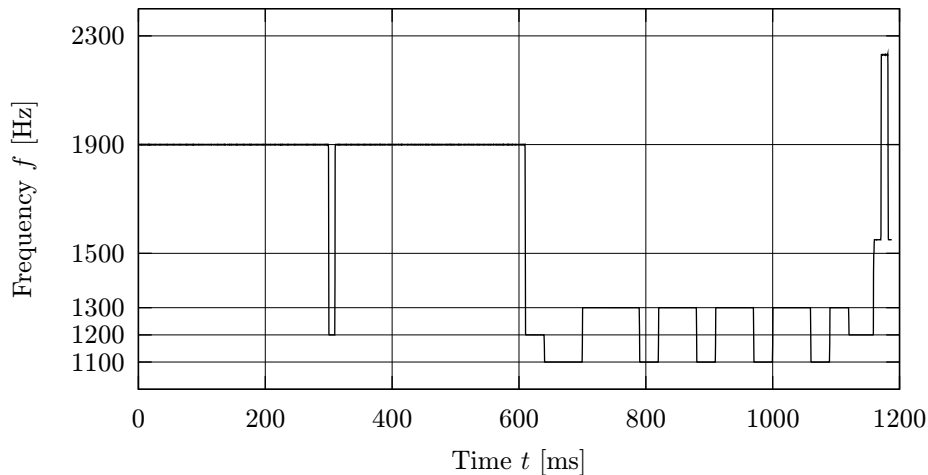

Figure 4.10: The 16-bit VIS code of MP115 mode with a 0x2923 value.

VIS used in narrowband modes has a very little in common with the original standard. Initially, during vertical synchronization N -VIS pulses of 1900Hz and 2300Hz in 100 ms are sent, followed by a start bit of 1900 Hz (see fig. ??).

All code bits have a duration of 22 ms (modulation speed is 45.45 Bd). Logic one has 1900 Hz and logic zero 2100 Hz. The code word length is 24 bits and it is divided into four groups of 6 bits, bits are sent in the following order:

Each group has the following meaning:

- ▷ Group 0 (5–0) = 101101
- ▷ Group 1 (15–10) = 010101
- ▷ Group 2 (25–20) = N-VIS
- ▷ Group 3 (35–30) = 010101 **xor** N-VIS

For example, MP73-N has N-VIS = 000010 (0x02) and the whole code word is:
101101 010101 000010 010111.

MP modes use the same principle as PD modes. The sync takes 9.0 ms followed by a short 1500 Hz gap of 1.0 ms, then odd scan-line Y brightness is sent followed by the $R - Y$ and $B - Y$ chrominance signals. The chrominance signals are the average of two neighborhood scan-lines. The scan-line is ended by the even Y luminance signal. These sequence is repeated $128\times$.

MP modes also have narrowband variants (MPxx-N) and their video signals occupy frequencies from 2044 to 2300 Hz.

The MR and ML modes use YCrCb color coding in 4:2:2 format, same as the Robot 72 Color mode. Horizontal syncs are same as in MP modes. The scan-line begins with luminance Y , then 0.1 ms gap is sent followed by $R - Y$, a gap, and $B - Y$, the line then ends with a 0.1ms gap. These gaps should have the same

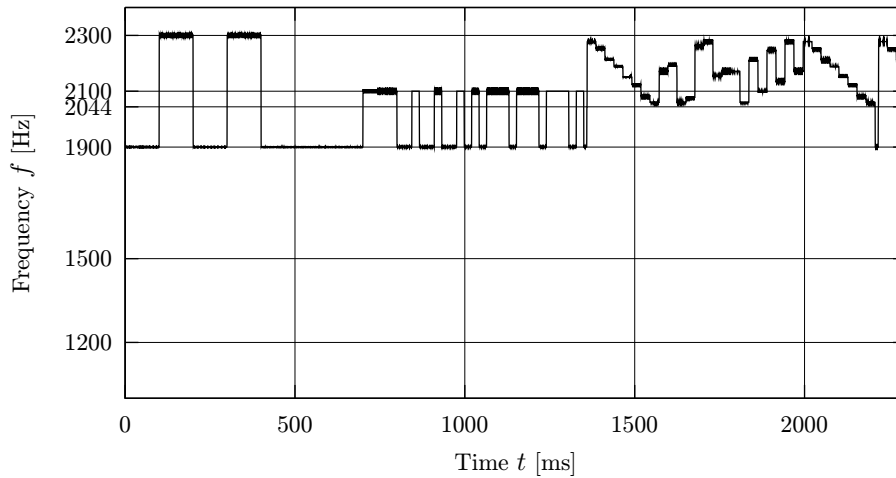

Figure 4.11: Vertical synchronization and scan-line of the MP110-N narrowband mode.

frequency as the last pixel of the previous color component. The MLxx group has a high resolution of 640×496 .

The MC-N modes are narrowband, but they use RGB color coding. Horizontal pulses last 8.0 ms and are followed by a 0.5 ms gap of 2044 Hz. The order of color components is red – green – blue.

4.4.4 Martin HQ

The Martin HQ system from Martin Emmerson’s workshop was released at the end of 1996. These modes were developed for Robot 1200C, SUPERSCAN 2001 and other compatible converters with the EPROM version 4.6, or 1.6. Unlike previous Martin modes, they use YCrCb color coding. The transmission time of chrominance signals is half of luminance (format 4:2:2). There are 6 signals sent between two doubled syncs. The first three signals create an odd scan-line: luminance Y , $R - Y$, $B - Y$. And the next three signals contain even scan-line: luminance Y , $Y - R$, $Y - B$. The opposite “polarity” of chrominance compensates for possible color distortion when signals are not tuned precisely. The HQ1 mode has 90 seconds for image transmission and HQ2 has 112 seconds.

Unfortunately, the author refused to disclose the exact specification of the system, so this improved system is not commonly found.

Mode name	Transfer time	Resolution	VIS 16-bit	Color sequence	Scan-line (ms)				Speed (lpm)
					Sync	Y	R-Y	B-Y	
MP115	115 s	320×256	0x2923	YCrCb	9.0	223.0	223.0	223.0	133.037694
MP140	140 s	320×256	0x2a23	YCrCb	9.0	270.0	270.0	270.0	110.091743
MP175	175 s	320×256	0x2c23	YCrCb	9.0	340.0	340.0	340.0	87.591241
MR73	73 s	320×256	0x4523	YCrCb	9.0	138.0	69.0	69.0	419.140761
MR90	90 s	320×256	0x4623	YCrCb	9.0	171.0	85.5	85.5	340.618791
MR115	115 s	320×256	0x4923	YCrCb	9.0	220.0	110.0	110.0	266.489007
MR140	140 s	320×256	0x4a23	YCrCb	9.0	269.0	134.5	134.5	218.858289
MR175	175 s	320×256	0x4c23	YCrCb	9.0	337.0	168.5	168.5	175.361683
ML180	180 s	640×496	0x8523	YCrCb	9.0	176.5	88.25	88.25	330.305533
ML240	240 s	640×496	0x8623	YCrCb	9.0	236.5	118.25	118.25	248.292986
ML280	280 s	640×496	0x8923	YCrCb	9.0	277.5	138.75	138.75	212.276667
ML320	320 s	640×496	0x8a23	YCrCb	9.0	317.5	158.75	158.75	185.960019

Narrowband modes:

Mode name	Transfer time	Resolution	N-VIS	Color sequence	Scan-line (ms)				Speed (lpm)
					Sync	Y	R-Y	B-Y	
MP73-N	73 s	320×256	0x02	YCrCb	9.0	140.0	140.0	140.0	210.526316
MP110-N	115 s	320×256	0x04	YCrCb	9.0	212.0	212.0	212.0	139.860140
MP140-N	140 s	320×256	0x05	YCrCb	9.0	270.0	270.0	270.0	110.091743
					Sync	R	G	B	
MC110-N	110 s	320×256	0x14	R-G-B	8.0	143.0	143.0	143.0	137.142857
MC140-N	140 s	320×256	0x15	R-G-B	8.0	180.0	180.0	180.0	109.389243
MC180-N	180 s	320×256	0x16	R-G-B	8.0	232.0	232.0	232.0	85.166785

Table 4.10: The parameters of MMSSTV modes.

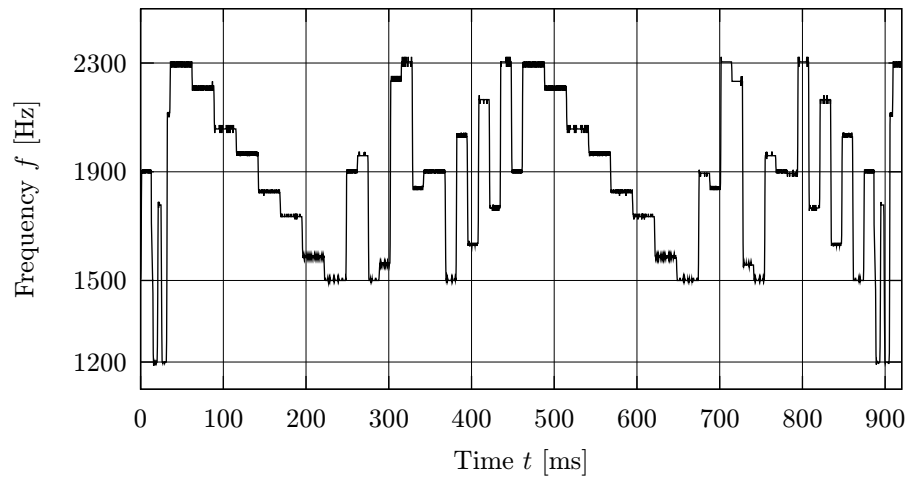

Figure 4.12: Two scan-lines of Martin HQ modes, when color bars are sent.

5

List of SSTV modes

System	Mode	Colors	VIS code	Duration [s]	Lines	Columns	lpm
Amiga Video Transceiver	AVT 24	RGB	64,65,66,67 ^a	31	128	128	960.000
	AVT 90	RGB	68,69,70,71 ^a	98	240	256	480.000
	AVT 94	RGB	72,73,74,75 ^a	102	200	320	384.000
	AVT 188	RGB	76 ^b ,77,78,79 ^a	196	400	320	384.000
	AVT 125 BW	BW	80,81,82,83 ^a	133	400	320	192.000
FAX480		BW	85	138	480	512	224.497
FAST FM		YCrCb	90 ^f	13	240	320	1118.881
Martin	M1	RGB	44	114	256	320	134.395
	M2	RGB	40	58	256	320	264.553
	M3	RGB	36	57	128	320	134.395
	M4	RGB	32	29	128	320	264.553
Martin HQ	HQ1	YCrCb	41	90	240	320	85.055
	HQ2	YCrCb	42	112	240	320	68.680

System	Mode	Colors	VIS code	Duration [s]	Lines	Columns	lpm
MMSSTV	MC110-N	RGB	0x14 ^e	110	256	320	137.143
	MC140-N	RGB	0x15 ^e	140	256	320	109.389
	MC180-N	RGB	0x16 ^e	180	256	320	85.167
	MP73	YCrCb	0x2523 ^d	73	256	320	210.526
	MP115	YCrCb	0x2923 ^d	115	256	320	133.038
	MP140	YCrCb	0x2a23 ^d	140	256	320	110.092
	MP175	YCrCb	0x2c23 ^d	175	256	320	87.591
	MP73-N	YCrCb	0x02 ^e	73	256	320	210.526
	MP110-N	YCrCb	0x04 ^e	115	256	320	139.860
	MP140-N	YCrCb	0x05 ^e	140	256	320	110.092
	MR73	YCrCb	0x4523 ^d	73	256	320	419.141
	MR90	YCrCb	0x4623 ^d	90	256	320	340.619
	MR115	YCrCb	0x4923 ^d	115	256	320	266.489
	MR140	YCrCb	0x4a23 ^d	140	256	320	218.858
	MR175	YCrCb	0x4c23 ^d	175	256	320	175.362
	MR180	YCrCb	0x8523 ^d	180	496	640	330.306
	MR240	YCrCb	0x8623 ^d	240	496	640	248.293
	MR280	YCrCb	0x8923 ^d	280	496	640	212.277
MR320	YCrCb	0x8a23 ^d	320	496	640	185.960	
MSCAN	TV-1	RGB	104	320	256	320	84.383
	TV-2	RGB	105	320	256	320	134.530
Pasokon	P3	RGB	113	203	496	640	146.565
	P5	RGB	114	305	496	640	97.710
	P7	RGB	115	406	496	640	73.282
PD	PD 50	YCrCb	93	50	256	320	309.151
	PD 90	YCrCb	99	90	256	320	170.687
	PD 120	YCrCb	95	126	496	640	235.997
	PD 160	YCrCb	98	161	400	512	149.177
	PD 180	YCrCb	96	187	496	640	159.101
	PD 240	YCrCb	97	248	496	640	120.000
	PD 290	YCrCb	94	289	616	800	128.030
Proskan	J120	RGB	100	120	240	320	128.046

System	Mode	Colors	VIS code	Duration [s]	Lines	Columns	lpm
Robot	Color 12	YCrCb	0	12	120	160	600.000
	Color 24	YCrCb	4	24	120	160	300.000
	Color 36	YCrCb	8	36	240	320	400.000
	Color 72	YCrCb	12	72	240	320	200.000
	B&W 8	BW	1, 2, 3 ^c	8	160	120	900.000
	B&W 12	BW	5, 6, 7 ^c	12	320	240	600.000
	B&W 24	BW	9, 10, 11 ^c	24	320	240	300.000
	B&W 36	BW	13, 14, 15 ^c	36	320	240	200.000
Scottie	S1	RGB	60	110	256	320	140.115
	S2	RGB	56	71	256	320	216.067
	S3	RGB	52	55	128	320	140.115
	S4	RGB	48	36	128	320	216.067
	DX	RGB	76 ^b	269	256	320	57.127
Scottie DX2		RGB	80	136	256	320	112.905
SP-17 BW		BW	125	17	256	128	895.520
Vester Color FAX		RGB	86	414	480	512	74.832
Wraase SC1	8	BW	17, 18, 19 ^c	8	120	128	1000.000
	16	BW	21, 22, 23 ^c	16	120	256	500.000
	24	BW	25, 26, 27 ^c	24	256	128	930.520
	32	BW	29, 30, 31 ^c	32	240	256	500.000
	24	RGB	16	24	128	128	900.000
	48	RGB	20	48	128	256	489.102
	48Q	RGB	24	48	256	128	900.000
	96	RGB	28	96	256	256	500.000
Wraase SC2	30	RGB	51	30	128	320	249.595
	60	RGB	59	60	256	320	249.600
	120	RGB	63	120	256	320	126.175
	180	RGB	55	180	256	320	84.383

Notes:

- ▷ *a* – VIS code order: Normal, Narrow mode, QRM mode, Narrow+QRM;
- ▷ *b* – Scottie DX and AVT 188 were created at the same time and accidentally share the same VIS code;
- ▷ *c* – VIS codes for each color component (red, green, blue). The green component is commonly used for BW images;
- ▷ *d* – Uses 16 bit VIS (see [sec. 4.4.3](#));

- ▷ *e* – Uses another digital code N-VIS (see **sec. 4.4.3**);
- ▷ *f* – Uses odd parity;

6

SSTV Equipment

6.1 Transceiver

SSTV images can be received via a standard communication transceiver (or receiver) that covers the HF amateur bands and supports SSB modulation or a VHF transceiver with FM. There is no need for further modifications, although the IF filter should not be narrower than 2.5 kHz, a width of 3 kHz is recommended. The SSTV signal is taken from the audio output or headphone jack that is plugged into the SSTV decoding device.

For transmission, a common HF or VHF transceiver with an SSTV signal connected to the microphone jack should be used. The band in which you are determines the usage of LSB or USB, which is the same as in voice transmission.

No transmitter modifications are necessary. But when operating SSB, it is important to realize that the broadcast of very loud speech can be achieved at approximately $\frac{3}{4}$ of output power, so the load of the output amplifier is fairly low and there is no danger of overheating. But SSTV signals transmitted via a voice channel create a 100% load due to the presence of an auxiliary carrier.

Keep the limits set by the manufacturer for SSB operations. The usual maximal keying with full load is about 20 minutes for professional equipment. Modern transceivers switch on cooling during heavy load and it is not suitable to switch off TRX immediately after the end of QSO, but wait a few minutes for the equipment to cool down.

SSTV transmission is not dangerous, but it is advised to adhere to some safety measures.

6.2 Station equipment for visual communication

1. *Computer system* – a sound card or other special hardware interface and software.

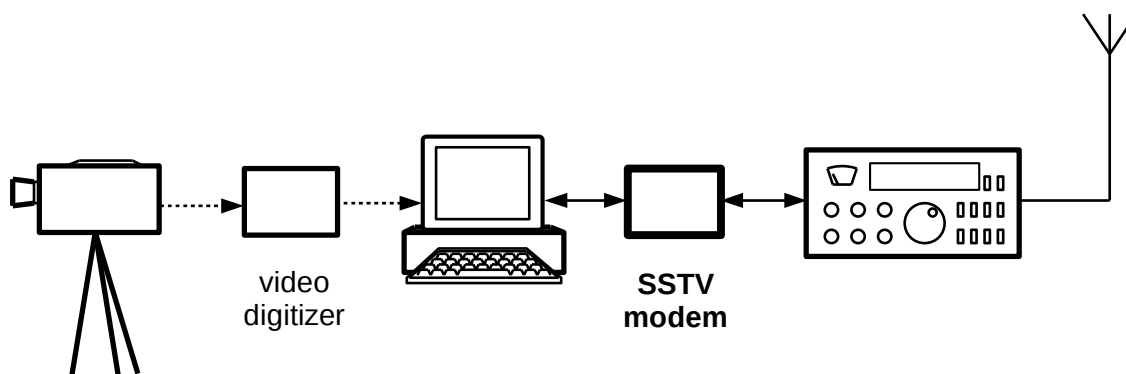

Figure 6.1: SSTV station equipped for computer operations.

Currently, the most common SSTV device is a personal computer with a sound card. There are a number of programs for personal computers with Windows, Mac, GNU/Linux and DOS. There are also special modems (MFJ, Roy1, AOR TDF370,...) or the very simple Hamcomm modem. Hamcomm is based on a simple comparator circuit and connected to the RS232 serial port. But it is only usable for old DOS based software. The most varied software options are for Windows and a sound card.

Additional equipment can be used such as a web camera or a television card with analog video input.

2. *Digital scan-converter* is a stand-alone device that digitizes received signals and stores them in memory. The decoder converts memory content to analog signals (PAL or NTSC) for display on a normal TV set or monitor. The converter can be connected to any color or monochrome camera, which then transmits live images. Due to digital data processing, most converters are equipped with a computer interface. This allows for the addition of texts to images and the upload and storage of images to/from computer. Tape recorders were historically often used to record SSTV and for storing QSO images.
3. Long persistence CRT monitor and circuits for signal filtering and vertical and horizontal drives, etc. The usage of these monitors is long over. Electro-mechanical scanners or sampling cameras were used as SSTV signal sources in these days.

6.3 Historical tidbits

6.3.1 SSTV monitor

Long persistence monitors were the most important SSTV equipment in the seventies. There were other commercial products available, but most homemade monitors were built by SSTV enthusiasts.

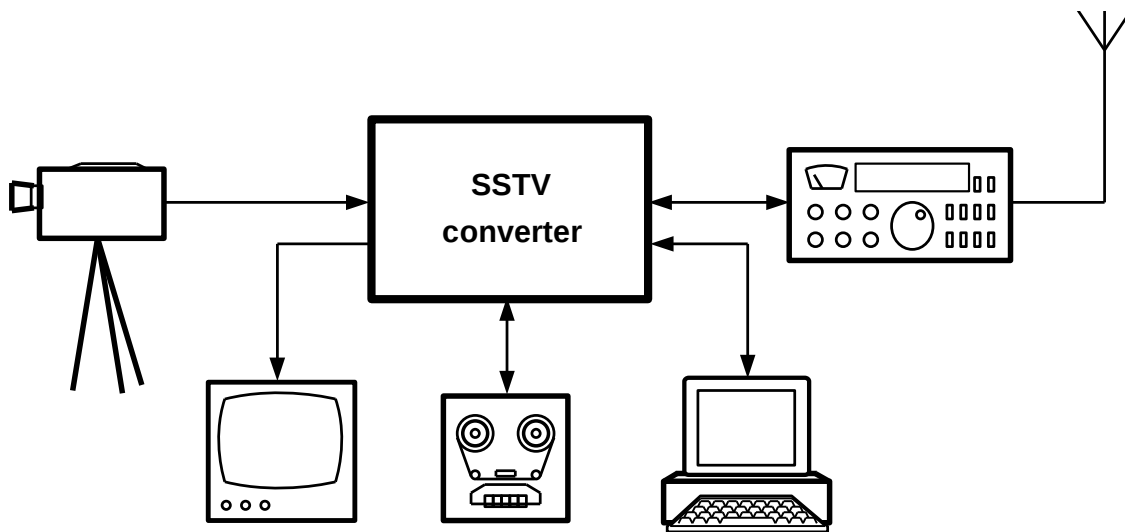

Figure 6.2: An SSTV station equipped with a stand-alone SSTV converter.

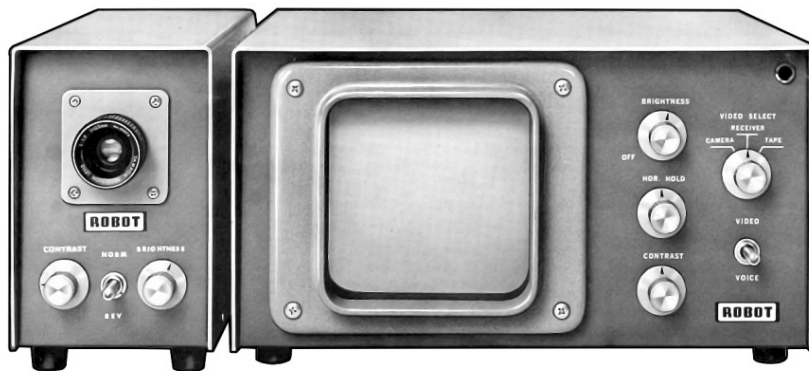

Figure 6.3: Monitor *Robot Model 70* and camera *Model 80* from Robot Research Inc.

Products from Robot Research Inc., Wraase Electronics and Venus were very popular. These products were not produced for just the ham radio market, but were also found in the image communication over telephone lines markets.

A typical monitor consists of several basic parts, see **fig. 6.4**: input and limiter circuits, video and sync detectors, scanning circuits, cathode ray tube drivers and power supply. The long persistence CRTs are made with special *photoluminescence phosphor*. In simple terms, phosphorescence is a process in which the energy absorbed by a substance is slowly released in the form of light. These CRTs were most used in radar displays or oscilloscopes for the monitoring of slow processes.

The path of frequency modulated signals that contains video and syncs goes through the limiter, where the signal is limited to constant amplitude and then flows into image discriminator. There are video detecting circuits for syncs and

video separation here. Then signals from the discriminator are amplified and drive both the vertical and horizontal scans. The output voltage of these circuits is the saw-tooth voltage and drives deflection plates of long persistent CRT.

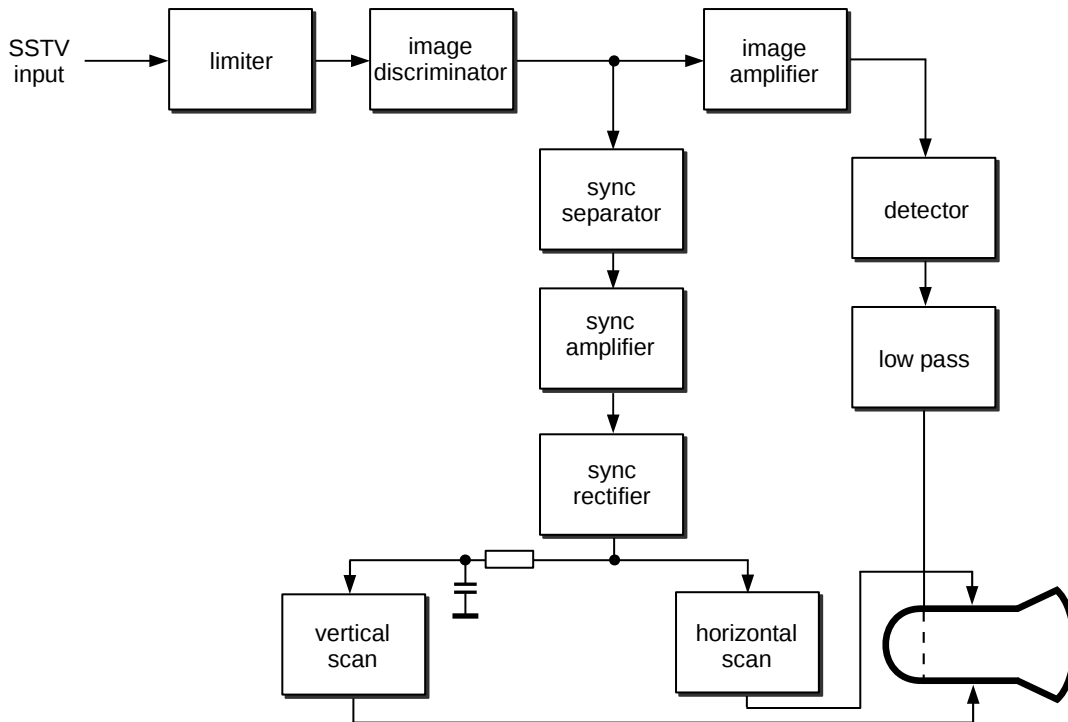

Figure 6.4: Block scheme of SSTV monitor.

After the separation of sync, the image signal goes to the image intensifier and detector. After filtration, the signal is fed to the cathode ray tube grids and modulates the electron beam. Subsequently the image is displayed on the screen. The disadvantage of this process is that the image is seen clearest during the reception and then the brightness fades. To be able to view the image after the 8 seconds transfer a well darkened room was necessary.

6.3.2 Scanning devices

The image scanning methods used in early SSTV transmission can be classified into electronic and electro-mechanical methods. Purely electronic systems used cameras with a sensor element like vidicon, plumbicon or other camera tubes.

In SSTV cameras, the vertical scan frequency was adjusted from 50 Hz to 16.6 Hz (i.e. horizontal scanning frequency for 7.2s SSTV or 15 Hz for 60Hz standard). Then a whole camera or just a deflection unit only was rotated 90°. The TV camera

scans the image line by line, providing the sampling circuit with input. The sampling circuits reads short samples from each line during each camera scanning beam cycle. All the samples from scan-lines of the FSTV camera create one scan-line of slow-scan TV picture. In the next scanning beam cycle, the sampling position moves to the left and creates the next scan-line. The cycle is repeated until the whole picture is sampled.

The next type of image scanner often used was a scanner with a photomultiplier for the scanning of transparent or non-transparent originals (*FSS – Flying Spot Scanner*). The light through transparent originals falls on the photomultiplier, whose output is a voltage that is proportional to the transparency of the original. This creates an amplitude modulated video signal, which can be converted to the frequency modulated signal of SSTV.

The electromechanical scanner was used for non-transparent originals, which were scanned from a rotating roller. The mechanical part was assembled from a roller with the mounted original, a screw-thread for sliding and a drive unit with a synchronous motor. The second part consisted of a lens, a light bulb, a photo transistor and sensor circuit for the generation of the SSTV signal.

6.4 Early FSTV/SSTV converters

SSTV/FSTV converters usually sample and digitize incoming SSTV signals and store them in memory. Simultaneously, the memory content is read and converted to an analog signal, which controls the fast-scan TV modulator.

The received SSTV signal is limited to the constant amplitude in input circuits and then continues into an analog/digital converter. Digital data is processed by the converter's microprocessor firmware. Its task is to digitize every scan-line of the image and store it in memory. The memory capacity is equivalent to the resolution and number of colors.

The memory is continuously read in the FSTV scanning frequency and data goes into a digital/analog converter. The output analog signal is displayed on normal television. The SSTV image is stored in memory until it is overwritten by the newly received image. The reverse process of digitization of an FSTV image and its transmission by SSTV is similar.

One of the first SSTV converters was the Robot 300 model. This converter contains 69 transistors, 41 integrated circuits, 41 diodes and its heart is a silicon memory tube. The function of this tube was the same as a cathode ray tube or vidicon. The electron beam electromagnetically diffracted and focus was directed into the scanning electrode, which consisted of a dielectric memory layer used for analog image recording.

The modern concept of converters began with Robot 400C and its successors 450C and especially 1200C, which became available in 1986. In these years everyone, who was serious about SSTV had to own one! A camera and a monitor were necessary.

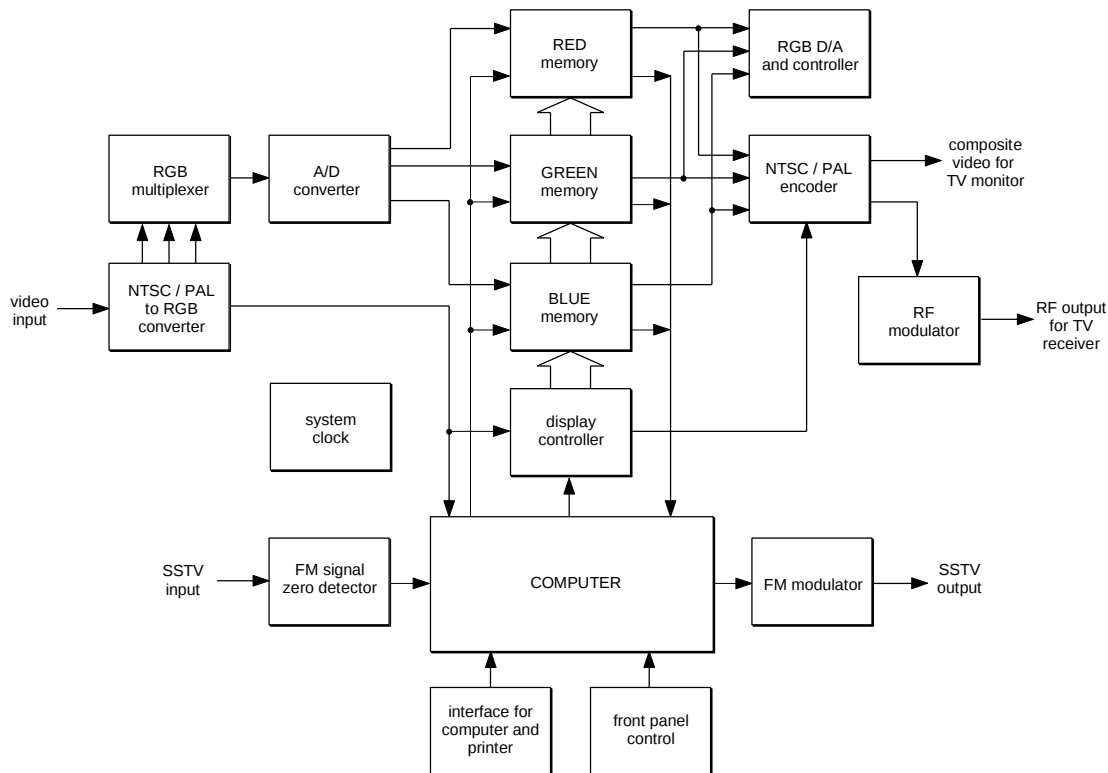

Figure 6.5: Block scheme of stand-alone SSTV/FSTV converter.

Robot 1200C was modified with optional EPROMs and a timing circuit, so it can be used for operations in various SSTV modes. Its production ended in 1992, but during the nineties there were clones available on the market – FH-21P in Germany, SUPERSCAN 2001 in the United Kingdom, LM-9000C and Ribbit 1200C. These machines can still be used for SSTV operations and many old-school operators own them. They are also sometimes available in Ebay auctions.

6.5 SUPERSCAN 2001

The production of SUPERSCAN started shortly after the end of Robot 1200C production. Its designer Jad Bashour had worked with Martin Emmerson. SUPERSCAN is actually a much improved 1200C and includes improved modifications to the original 1200C. The price of this unit was about £ 750 and with additional modules the price could exceed £ 1000.



Figure 6.6: The front panel of SUPERSCAN 2001

Main features of SUPERSCAN 2001:

- ▷ Total compatibility with all classic SSTV systems.
- ▷ System upgrade is simply achieved by an EPROM upgrade. Its last version 1.6 supports these modes:
 - ▷ Color modes:
 - ▷ Scottie S1, S2, S3, S4, DX;
 - ▷ Wraase SC-1: 24, 48Q, 48, 96;
 - ▷ Robot Color 12, 24, 36, 72;
 - ▷ Wraase SC-2: 30, 60, 120, 180;
 - ▷ AVT 24, 90, 94, 188, plus QRM, Narrow variants.
 - ▷ B&W modes:
 - ▷ Robot 8, 12, 24, 36;
 - ▷ Wraase SC-1 8, 16, 16Q, 32;
 - ▷ AVT BW 125.
 - ▷ Radio fax reception:
 - ▷ 60, 90, 120, 240 lpm.
- ▷ Contains four memory banks and stores images in a resolution 256×240 with 18bit color depth (262,144 colors).
- ▷ TV PAL decoder with delay lines for perfect image digitization.
- ▷ High speed parallel interface for computer connection.
- ▷ RGB video output.
- ▷ Control by computer mouse available (firmware 1.3).
- ▷ Text addition.
- ▷ Backup of CMOS memories for texts and configuration.
- ▷ High stability oscillator for free-run reception.

6.6 Tasco TSC-70P

A modern type of converter is the TSC-70P (TSC-70N works with NTSC norm). This converter includes a DSP for better reception of weak signals. It supports all conveniences such as the automatic detection of VIS code and free-run reception.



Figure 6.7: Japan converter Tasco TSC-70P.

Supported modes:

- ▷ Martin M1, M2;
- ▷ Scottie S1, S2;
- ▷ Robot Color 36, 72;
- ▷ AVT 90, 94 (Narrow regime, only in TSC-70N available).

Image processing is done in a real-time digitizer, and images are stored in memory with a resolution of 416×256 with 2 million colors. With an optional EM-70 module, the video memory capacity can be doubled.

Tasco TSC-70P working with PAL video signal, you need to have a television with video inputs or a color TV monitor. Control equipment is made via an infrared remote control (WR-70) or via a RS232 serial interface. Using EB-232VP software, images can be moved at 115 kbit/s speed between the converter and the computer.

The desktop PC can be equipped with an optional ISA card EB-70P that triples the speed of data exchange. For greater convenience the converter can be controlled by a computer program i.e. HIRES-70P or WINTSC.

The converter weighs 450 g (60 g remote control) with dimensions of 140 mm (width) \times 140 mm (length) \times 25 mm (height) and it is powered by DC 11–15 V with a consumption smaller than 250 mA. It is specifically designed for mobile or portable operations and can be used with miniature television, such as EV-5xx from CASIO, with small LCD display 7 cm, it weighs about 195 g.

6.7 Interactive Visual Communicator VC-H1

The VC-H1 was produced by Kenwood. It is a device intended for mobile SSTV operations. The dimensions are similar to hand-held transceivers – $7 \times 3.5 \times 17$ cm. The unit has a built-in CCD Camera, 1.8" LCD color monitor and a microphone. Its memory allows the storage of an uncompressed image in the image buffer and 10 JPEG compressed images. The JPEG memory has a battery backup, so it is possible to store images when the unit is switched off.

The converter has an RS232 interface for computer connection (115 kbit/s). The input and output for external video signals is only NTSC.

VC-H1 is powered by four AA batteries or external DC supply with 6.0 V. The maximum consumption is 650 mA when digitizing an image, otherwise the consumption is 450 mA when the LCD is on or 100 mA in stand-by mode with the LCD off.



Figure 6.8: Mobile SSTV converter VC-H1.

Supported modes:

- ▷ Martin M1, M2;
- ▷ Scottie S1, S2;
- ▷ Robot Color 36, 72;
- ▷ AVT 90, 94;
- ▷ FAST FM.



Computer operations

In one afternoon, an equipped hamradio operator can begin receiving SSTV. All that is needed is to make a connection cable between a transceiver and a sound card and download some SSTV related software. Then tune into 14.230 MHz USB for 24 hour-a-day SSTV activity.

Programs for SSTV operations are very similar and provide equivalent basic functions, of course with different comfort levels. Some of them are intuitive and well-arranged, while others require studying a manual. Everybody has the possibility to choose from more variants and see what is best for him and what provides requested functions. Every operator must know these basic functions:

- ▷ to configure an accurate sampling frequency for reception and transmission,
- ▷ to set proper sound card volume levels,
- ▷ to use the tuning indicator,
- ▷ to manually change the transmission mode,
- ▷ to load and save images in common graphic formats,
- ▷ to create an image gallery for transmission and
- ▷ to add text into transmitted images.

7.1 Hardware configuration

Take your time in selecting a suitable configuration of the computer in your hamshack. The unpleasant fact is that, operating system and software requirements are constantly on the rise. For SSTV operations it is possible to use obsolete PCs with old 386 processors. The *Hamcomm* modem and some other popular programs from the nineties run on DOS. In this case, 4 MB of RAM, a hundred megabytes hard disk and SVGA graphics card with 256 colors are enough. But graphic cards with 32 or 64 thousand colors are more suitable.

To use a sound card a good PC is needed. At the least it should be configured with 150MHz Pentium, 64 MB RAM and few gigabytes hard disk. A graphics card needs to support 1024×768 resolution in 64 thousands or 16.7 million color mode.

The minimal operating system is Windows 95 OSR 2, but some new programs may not run in Win95. I recommend having better hardware but you don't need the latest mega-hyper model.

There are also software products for MacOS X and for GNU/Linux, but the largest selection is for Microsoft Windows.

7.2 Sound card as a modem

A sound card is standard PC equipment these days. It can be used as a music player, for multimedia, games and recording. The main application of a sound card in hamshacks is as a MODEM. The modem – MODulator/DEModulator allows computer information to be transmitted and received over physical media like radio waves or telephone lines. The modem translates analog signals to digital data and vice versa.

7.2.1 Sound processing in PCs

To allow the computer to work with sound signals, the signal must be converted into a format suitable for data processing (digital or discrete signal).

7.2.1.1 Sampling

The digital conversion process begins with *sampling*. Sampling is an activity which periodically scans the current value of the analog signal. For example, this happens 11,025 times per second or depends on a user defined sample rate supported by the sound card. The sampling frequency of sound cards ranges from 8 kHz suitable for internet telephony up to 96 kHz designated for more exacting requirements of recording studios.

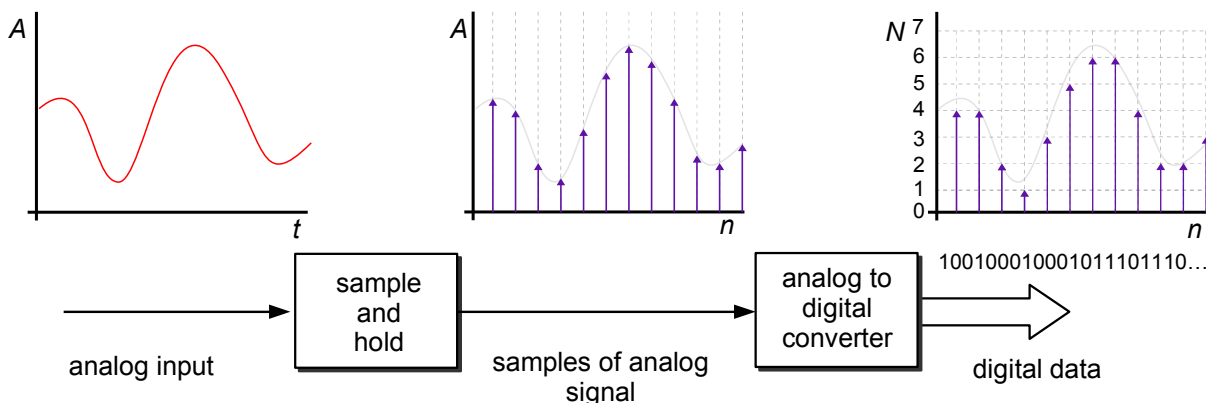

Figure 7.1: The conversion of an analog signal into numeric data.

The answer to the question of what sampling frequency should be used gives us Shannon's theorem (also known as Nyquist-Kotělnik-Shannon theorem). It defines that a signal continuous in time, containing spectral components with the highest frequency f_{max} , can be clearly reconstructed from a sequence of evenly spaced samples with a sampling frequency f_s greater than double f_{max} :

$$f_s > 2f_{max}$$

You can see the importance of Shannon's theorem in the example below. The signal in **figure 7.2a** expresses the dependency between time t and amplitude A . Using Fourier's analysis, we can find (see **chapter 3.1.1**), that the signal contains two harmonic components, showed in **7.2b**.

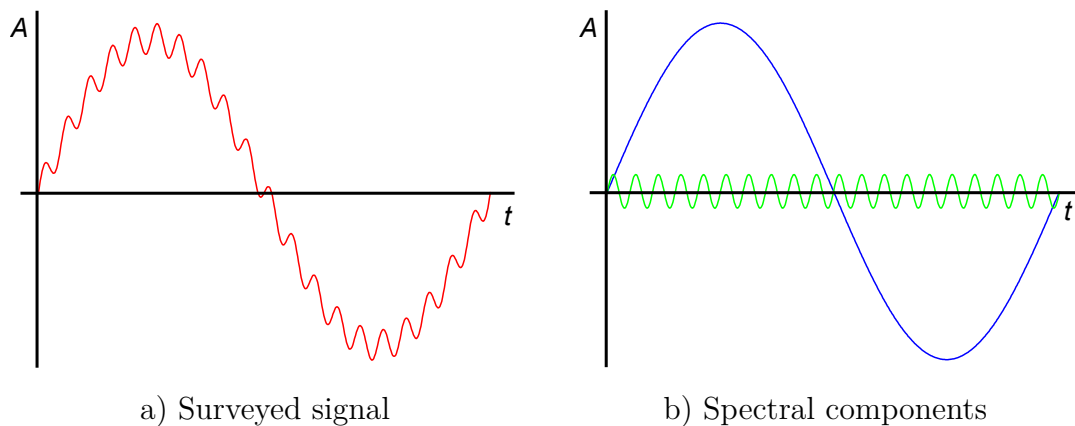

Figure 7.2: Example of signal.

By using Fourier's transformation, the signal can also be expressed as a dependency between amplitude A and frequency f – *signal spectrum*. Both frequency components are evident f_1 and $f_2 = f_{max}$ in the signal in **fig. 7.3**.

For explicit signal reconstruction the condition $f_s > 2f_{max}$ must be satisfied, see **fig. 7.4**. If a sampling frequency is lower than $2f_{max}$ then the higher frequency components are lost. This error is called *aliasing*.

For the sampling of common narrow band signals like SSTV, RTTY, PSK31 or WEFAX, which are transferred via SSB channel with a bandwidth of about 2 500—3 000 Hz; a sample rate of 11,025 Hz is enough.

7.2.2 Analog-to-digital conversion

The next way of an analog signal continues to the analog-to-digital (A/D) converter. The current value of signal converted into digital data in this device. Some A/D converters work with a resolution of 8 or 16 bits according to type or settings of a sound card. The resolution of A/D converter indicates the accuracy of signal

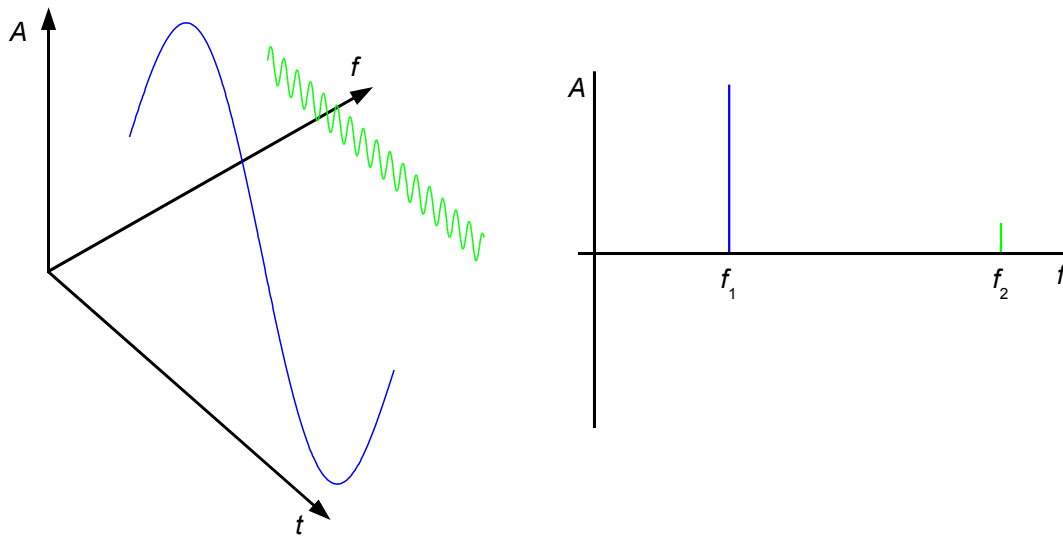

Figure 7.3: The frequency spectrum of signal in **fig. 7.2a**

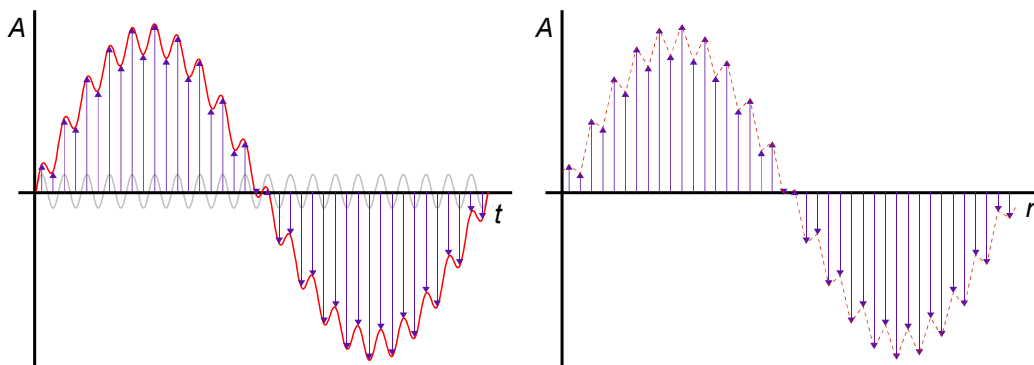

Figure 7.4: The signal sampled with a frequency higher than $2f_{max}$

amplitude scan in a defined range, for 8 bits it is $2^8 = 256$ values and for 16 it is 65,536.

Constrained resolution of A/D converter causes an *quantization* error. E.g. for 8 bit converter processing voltage range 0–5.0 V it's the error $5.0/(2^8 - 1) \doteq 0.02$ V. The 8bit converter cannot distinguish voltage levels lower than 0.02 V. So for input voltage 3.111 V it could find corresponding numeric value $10011110_2 \approx 3.098$ V or $10011111_2 \approx 3.118$ V because less significant bit is influenced by quantization error. The size of the error can be decreased by greater resolution of A/D converter. For our purposes the 16bit resolution is acceptable.

A modern sound cards could be equipped with digital signal processor (DSP), which extend card functions e.g. for filtering or data compression during recording

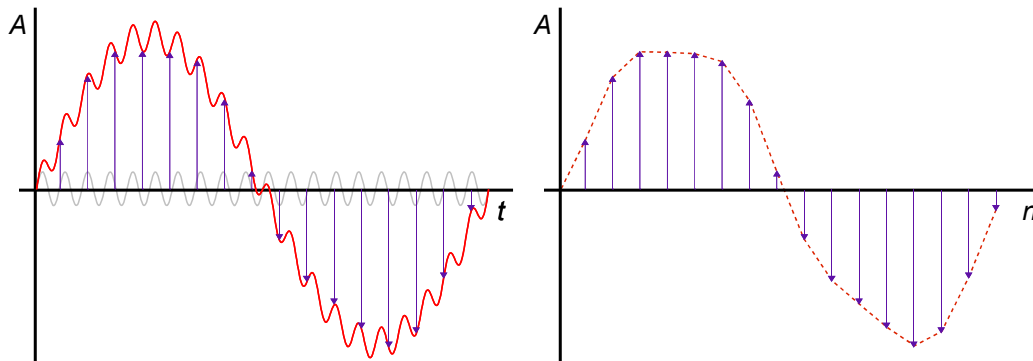

Figure 7.5: The sample rate does not meet the Shannon's theorem.

so it can lighten load of main computer CPU. E.g. *Sound Blaster Live!* contains programmable DSP labeled *EMU10K1*.

The choice of sound card type depends only on user's preferences and his intends of use. Many PCs has integrated sound card directly on a motherboard.

7.2.3 Interface between TRX and PC

The basic interface is made of shielded cables and 3.5mm jack plugs. A reception cable connects sound card input *Line In* and TRX headphones output or output for external speaker. For use of sound card microphone input can be used TRX output often labeled as *AF OUT* with impedance about $10\text{ k}\Omega$ which gives max. output voltage 100 mV . This output could be also used for interfacing tape deck or audio amplifier. Microphone input of sound card has automatic gain controller (AGC) for better recording and it is possible connect dynamics microphones with impedance from 600 to $10.000\ \Omega$.

For the transmission it is possible to use *Line Out* with impedance about $600\ \Omega$. The *Line Out* can be connected to microphone input of TRX or a rear panel connector like *PATCH IN*.

Some transceivers has a feature that microphone input and rear panel input are interconnected so it is necessary disconnect the microphone during AFSK transmission, because noise in hamshack could interfere with sound card signal! Check your TRX instruction manual for particular interfacing.

Last thing you need to set up is audio levels of received and transmitted signal. It can be made using operating system tools. The level of transmitted signal should be about $2/3$ of max. level. The signal could not be too attenuated or over-excited and distorted. You can detect it by monitor of outgoing signals. For receiving signal you can set proper level directly on TRX and check the input level in your SSTV software.

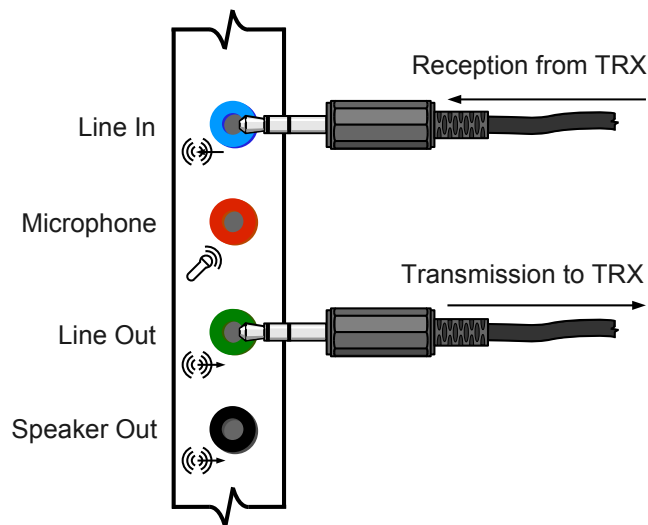

Figure 7.6: Basic interface between transceiver and sound card.

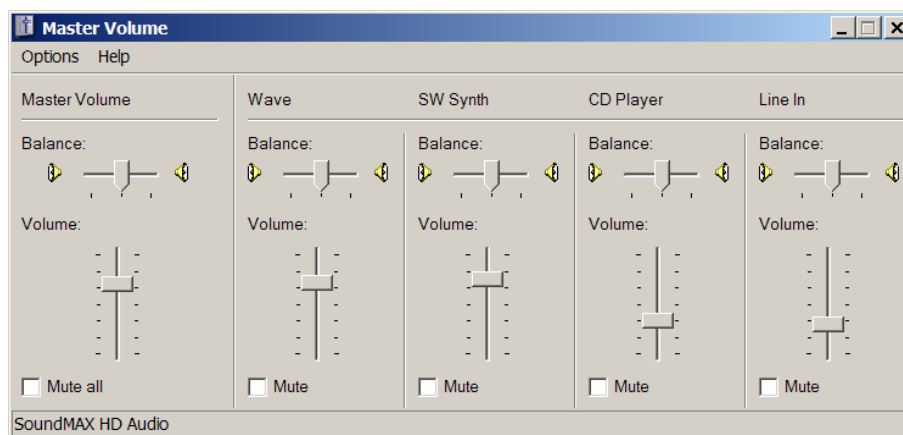

Figure 7.7: Software volume control.

After the audio mixer configuration it is useful to save your sound card settings (you can restore it every time before operations). A program *QuickMix* is can easily store your settings, because some other program can change it.

<http://quickmix.softpedia.com/>

7.2.4 PTT control

The PTT (Push-To-Talk) button switch between reception and transmission. For its control there are several possibilities:

1. Manual PTT switching. This handy method is not very elegant, but for the first experiments can be used.
2. Automatic switching can provide TRX with a VOX feature, when the TRX is automatically keyed by signal in the input. An disadvantage of this method may be that its reaction is not immediate, so in case of digital modes the beginning states of transmission or SSTV vertical synchronization can be lost. Keep in mind that operating system often produce malicious sounds that could accidentally key the transmitter.
3. Automatic PTT switch can control a computer. All SSTV programs support PTT control over a simple serial port (COM, RS-232) circuit. The circuit contains one switching transistor or opto-isolator and few passive parts. See **schematic 7.8** for details. The control signal is connected to RTS pin (7 at Cannon DB9 connector, 4 at DB25) or DTR (4 at DB9, 20 at DB25), selected pin can be changed by software configuration. The ground is on serial port wired on pin 5 at DB9 or 7 at DB25.

The big amount of handheld TRXs has a similar pin for microphone input and PTT. In this case an audio signal should be galvanically separated by capacitor about 100 nF and PTT signal is connected by resistor which resistance can be found in TRX instruction or you can connect trimming resistor about 15 k Ω and test the max. value when TRX switching.

4. Some transceivers support control over serial port. This CAT (Computer Aided Transceiver) interface can provide PTT switching. Over CAT interface can be send commands e.g. for tuning, mode control, etc. This method must be supported by software, for example MixW can control some TRXes so it is not needed to practically touch the TRX buttons.

What to do if your computer is not equipped with serial port? Some motherboard manufacturers build only one serial port and notebook manufacturers doesn't provide any serial port. If this happens you can use VOX or obtain USB/RS232 interface. Some programs also support similar switching circuit as described before but on parallel port (LPT).

7.2.5 Eliminate supply noise

A computer and a TRX can have slightly different electrical potential and in this case the direct connection causes annoying noise in communication channel. It is possible to remove noise with galvanic separation of both devices. The path of

audio signal should go through galvanic transformer and PTT control switch with opto-isolator, e.g. 4N25, 4N33, etc. Maybe you will need to change R2 to lower value when the opto-isolator is not switched properly when serial port signal is on.

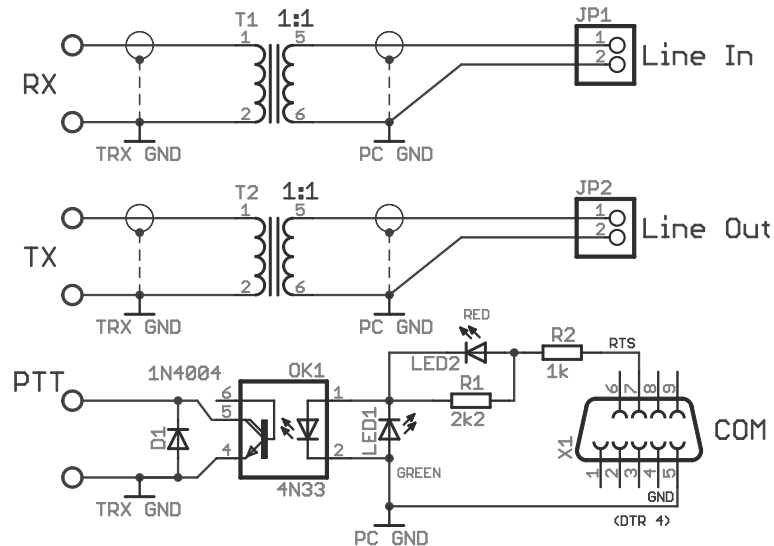

Figure 7.8: The galvanic separation of transceiver and sound card.

7.3 Timing oscillator configuration

There is description of synchronous (free-run) SSTV system in [section 3.6.1](#). Horizontal synchronization pulses (syncs) are detected only at the beginning of reception and after synchronization a reception device stops detect syncs and receive with free-run scan. Due to this there are excessive requirements for accurate timing of corresponding stations.

If the timing slightly differs then images are distorted – inaccurate timing causes image *slant*. You can see image slant for 0.01% timing difference in [fig. 7.9](#). If a transmitting station has higher timing (and reception lower) the image slants to the right ([7.9a](#)) in opposite situation to the left ([7.9b](#)).

However timing derived from sample rate is not used to be exactly 11,025.00 Hz, but often can differ up to few tenths of percent for each piece of hardware. For speech and music processing it doesn't matter, but in free-run transmission of SSTV it causes problems.

The configuration of accurate timing/sample rate for reception and transmission apart must be done to meet the strict requirements for synchronous SSTV broadcast. Your signal must be acceptable for any SSTV device.

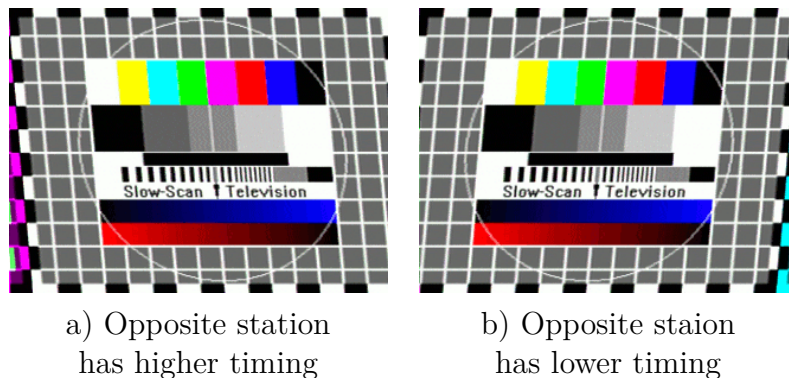

Figure 7.9: Image slant distortion when inaccurate timing is used for free-run modes.

All SSTV program are equipped with a tool for the timing configuration.

It is possible to receive SSTV signal from a band and by an edge of received image set the timing – program will automatically compute timing deviation. This way has a disadvantage, because not all SSTV stations has proper transmit timing. This is caused by offset between receiving and transmitting timing.

Much more precise way is use of shortwave broadcast of timing normal. Programs are equipped with special reception option, which displays spectrum in a second cycles. For timing setting just tune to the frequency of broadcast and leave to plot received pulses for several minutes.

The usable transmitter is a Moscow station RWM operating on frequencies 4,996.0, 9,996.0, 14,996.0 kHz with 8 kilowatts power. So it can be nicely received in Europe/Asia region. Select CW mode and tune your receiver directly to one of station frequencies. The unmodulated carrier is transmitted between 0. and 8. minute of an hour, telegraphy identification goes from 9. minute and then the timing signal will continue. Pulses in intervals 1/60 and 1 Hz goes between 10. and 20. minute and 10Hz pulses goes between 20. and 30. minute. This is repeated every 30 minutes.

The reception of WWV station is the next possibility. This station broadcast timing pulses and announcement on frequencies 2,500.0, 5,000.0, 10,000.0, 15,000.0, 20,000.0 kHz and uses double sideband (DSB) modulation. You can receive it with AM mode selected. The WWV operates from the North America, Fort Collins in Colorado. The used power ranges from 2.5 to 10 kW.

There is yet another way with WEFAX station reception, because these stations must have accurate timing too due to synchronous transfer.

The deviance error you should measure use to be expressed like absolute value of actual frequency, e.g. $f = 11024,45$ Hz or like deviance from f_s the $\Delta_f = -0,55$ Hz. Some program this measure in *parts per million (ppm)* unit. The ppm deviance can be computed:

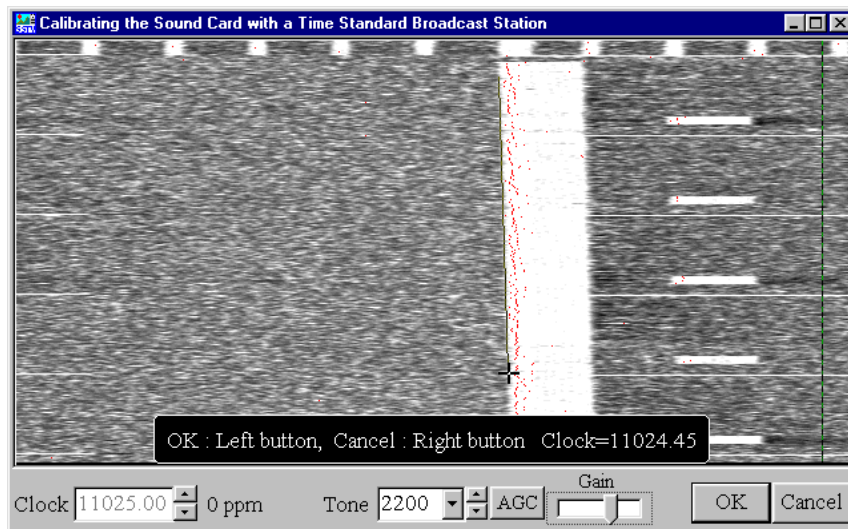

Figure 7.10: The configuration of accurate timing with RMW reception in MMSSTV.

$$\Delta = \frac{\Delta f}{f_s} \cdot 10^6.$$

For the $f = 11024,45$ Hz the deviance in ppm is:

$$\Delta = \frac{\Delta f}{f_s} \cdot 10^6 = \frac{-0,55}{11025,00} \cdot 10^6 \text{ ppm} \doteq -50 \text{ ppm}.$$

7.3.1 Transmit timing offset

There is necessity to configure transmit timing *TX offset* after the precise configuration of reception sample rate, when received SSTV images are not slanted. It is important for your own transmission, because inaccurate transmit timing causes image slant on reception side.

Some programs makes possible to monitor outgoing SSTV signals, so with this feedback it is practicable to check the TX offset – deviance between reception and transmission sample rate. The feedback can be internal or external. *External feedback* needs to connect Line Out and Line In with cable and it requires a sound card with full-duplex mode enabled. By this way you can set *TX offset* precisely on your own.

The *internal feedback* doing almost the same, but no external cables is needed. But some sound cards support only software feedback, so you will find zero deviance, but it is not real fact! Then the TX offset setting must be done with external feedback or with opposite station help. You need to disable any automatic corrections of received signals in this way.

Anyway you need to make “dry run” QSO before your first CQ. This helps you to uncover possible problems with TX offset, supply noise, audio level, etc.

The TX offset issue is often pretty messy. You can notice that some software running concurrent with your SSTV program can influence sound card output and then the change of sample rate occurs. Even the simple Volume Control tool can do this. So it is useful to stop unnecessary program running in the background. Especially programs that can influence sound card output or decreases stability of Microsoft Windows.

You may notice a strange behaviour if you are user of modern sound card with full duplex mode enabled with several output channels with a support of different sample rates for each channel. This is for example *SB Live! Value*. I have noticed that my TX offset randomly changes! I have this experiences with SB Live! Value and I found that another radio amateurs has same. You can try to set other sample rate than 11,025.0 Hz in this case, if this doesn't load your computer too much. For example try 48,000.0 Hz, this value is fixed sample rate (see your card user's guide) and best results you can achieve with using of this value or its half or quarter – 24,000.0 kHz or 12,000.0 kHz. When you change this value you need to recalibrate your accurate timing again.

To avoid these problems you can constantly monitor the outgoing signal through the external feedback with the TRX monitor enabled and before your today first transmission you will check that everything is fine. It's unpleasant that problems often occurs during QSO and then you will stunned by counterpart replay images.

7.4 SSTV tuning

First of all, we need to find SSTV stations by listening near calling frequencies. Thanks to typical SSTV sound and clattering of syncs it is not a problem to distinguish between SSTV and other communication modes.

Every SSTV program is equipped with precise tuning indicators – spectroscopes, see fig. 7.11. The spectroscope shows frequency band from 1000 Hz to 2500 Hz with marks for critical frequencies – 1200 Hz for syncs, 1500 Hz and 2300 Hz for the video signal.

Is is possible to simple detect band of video signal and syncs during clear reception. Rotate the tuning knob to achieve that all important frequencies are aligned in spectroscope display.

7.5 Video digitalization

The video digitizer should be additional equipment of SSTV station. The device can convert output signal from camera into computer form. There is a great choice

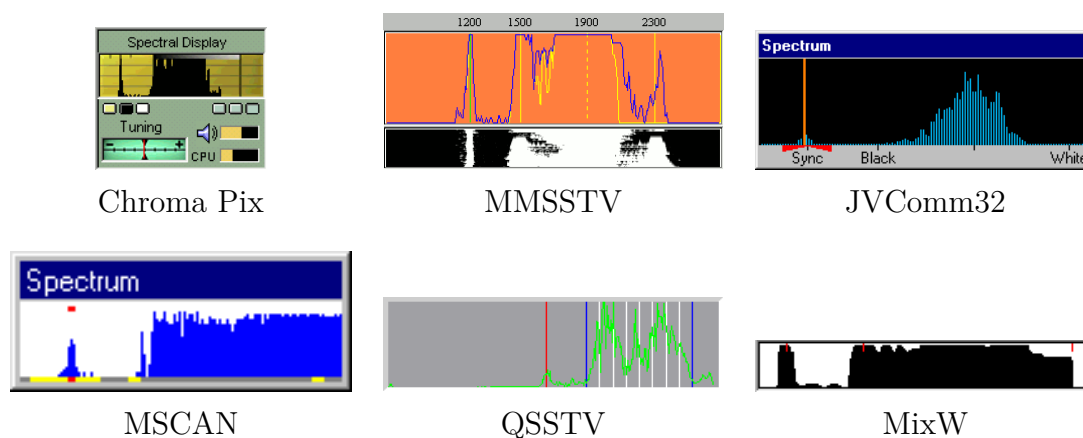

Figure 7.11: Spectrosopes in common SSTV programs.

of many different devices with varying capabilities, parameters and price. You can choose some webcams, frame grabbers, TV cards or digital cameras. Then your broadcast will not be limited only to pre-prepared images and you will have a lot more fun with live transmission.

The cheapest option are web cameras, they are equipped with a low-resolution CCD and low-cost optics, but provided quality is suitable for SSTV.

Another option is a TV card with video input. This possibility is more expensive because you must connect an external camera where the choices range from cheap CCTV black and white or color CCD cameras up to professional studio equipment.

7.6 Software for Windows

7.6.1 List of programs

7.6.1.1 SSTV software

- ▷ Chroma Pix – <http://www.barberdsp.com/>
- ▷ JVComm32 – <http://www.jvcomm.de/>
- ▷ MMSSTV – <http://mmhamsoft.ham-radio.ch/>
- ▷ MSCAN SSTV, Meteo – <http://www.mscan.com/>
- ▷ Winskan, SSTV32 – http://webpages.charter.net/jamie_5/
- ▷ W95SSTV – <http://www.barberdsp.com/w95sstv/w95sstv.htm>

7.6.1.2 Digital mode software with SSTV support

- ▷ MULTIPSK – http://f6cte.free.fr/index_anglais.htm
- ▷ MixW – <http://www.mixw.net/>

7.6.1.3 Software for dedicated interfaces

This programs don't use sound card as modes but special interfaces.

- ▷ Bonito Radiocom – <http://www.computer-int.com/rc.htm>
- ▷ Roy 1 – http://www.roy1.com/dvb_ham/dvb_1.htm
- ▷ Wraase SC-4 – <http://www.wesacom.de/sstv/>

8

Ham radio image operations

SSTV and radiofax broadcasting has their own rules, as well as other communication modes. If you already have a station equipped with some SSTV device and you are familiar with your SSTV software and have TRX interfaced with computer, you can start your image operations.

The ideal beginning is to ask experienced operator for a first test QSO. During this first QSO you or your partner can reveal some problems like bad settings of synchronization rates or noise affecting your computer signal or another problem you cannot reveal yourself. You can also contact your local SSTV party for help.

International Amateur Radio Union (IARU) recommends usage of amateur bands and recommends specified frequencies for voice, digital and image operations. Latest band plans dates of March 2009. For I.T.U. region I (Europe, Africa and Middle East and Northern Asia) there are recommended frequencies **8.1** in table.

Frequency	Recommendation
3,735 kHz	center of activity
7,165 kHz	center of activity (previously 7 030 –7 040 kHz)
14,230 kHz	center of activity
21,340 kHz	center of activity
28,680 kHz	center of activity
144,500 kHz	calling frequency for SSTV
432,500 kHz	narrowband SSTV
433,400 kHz	SSTV (FM/AFSK)

Table 8.1: Band plan recommendations for image communication.

The usage of side band is same like for voice operations, on bands below 10 MHz it is LSB and for above bands it is USB.

Before you start calling CQ make sure that chosen frequency and its neighborhood are free. SSTV operations are recommended in same sections of bands as voice communication and other modes so it is very unpleasant to interference each other. So before you start transmission ask on chosen frequency: "Is this frequency free for SSTV?" and again listen if the frequency is really free. There is unpleasant feature of some bands, e. g. 20 meters (14 MHz), that closer stations we can't detect, although only a noise sounds from speakers doesn't mean that no connection is make on the frequency.

There are centre of activities recommended on all bands, so for stations we should look around these frequencies. They are also can be used as calling frequency and after the station calling CQ on the frequency makes contact, the both station should tune to another free frequency (QSY) within the SSB segment.

Unfortunately, reality does not comply with this, so situation on very crowded band 20 meters is such, that stations are glued to each other around 14,230 kHz, they are interfering each other and weaker long distance stations are noised by undisciplined nearer stations. If you find that there is activity tune to another frequency at least ± 3 kHz. Good practice is chose frequency near centra of activity in 3kHz steps, e.g. on 15 meters:

... 21,334 21,337 **21,340** 21,343 21,346 ...

There is great probability to find stations calling CQ or your own CQ will be heard by the other side. You can call CQ by sending the image in the desired SSTV mode. The image must contain code CQ. It is good practice to place CQ test to the bottom of a picture, so a station that tunes to the frequency later finds what is going on. If you call CQ on calling frequencu add code QSY (Change to transmission on another frequency [(or on _____ kHz)] and specify frequency where you can continue the QSO.

An answering to CQ call is possible in two ways. The first one is that you answer by sending the image always in the same mode as called station. Of course, listen first that they are not another answering station. Add the call signs, e. g. OK1AAA de OK2BBB and report RSV into your picture. The second method, which is less used, you can contact the station by voice and than send your image.

Beyond that it depends on your choice what style you will prefer when you make the SSTV connection. It is possible to communicate only in SSTV, when all informations are transmitted in pictures or use SSTV as addition for voice operations, when both stations during QSO change few images. First way prefers mainly European stations, but in northern America is preferred second one for making QSOs. SSTV operation is closely linked with voice operation and although "one picture can say thousand words", it is sometimes more effective to use the microphone for

8.1 The reporting system

The message about report contains info about – readability, signal strength and picture quality report. The report message is transferred as a three-letter code RSV (Readability, Strength, Video), see **table 8.2**.

Readability – shows quality of signal reception in 5 degrees.

Signal strength – describes strength of received signal in 9 degrees. Tool to determine the strength is measuring instrument called S-meter, which is part of most receivers. Absolute deviation of his pointer is not very good indication, because by the S-meter we can only compare the signal with others in current conditions on a band.

Video – the quality of received image you can consider visually in 5 degrees, see **fig. 8.2**. The same method is used in ATV picture quality reporting system.

	R – Readability	S – Sig. strength	V – Video
1	Unreadable	Faint signal, barely perceptible	Barely perceptible
2	Barely readable, occasional words distinguishable	Very weak	Poor
3	Readable with considerable difficulty	Weak	Fair
4	Readable with practically no difficulty	Fair	Good
5	Perfectly readable	Fairly good	Excellent
6		Good	
7		Moderately strong	
8		Strong	
9		Very strong signals	

Table 8.2: Signal reporting with RSV code.

The report can expand information on interference (QRM, QRN) or if the image is slanted add entry SLANT. The example report is RSV 595 when the reception is awesome.

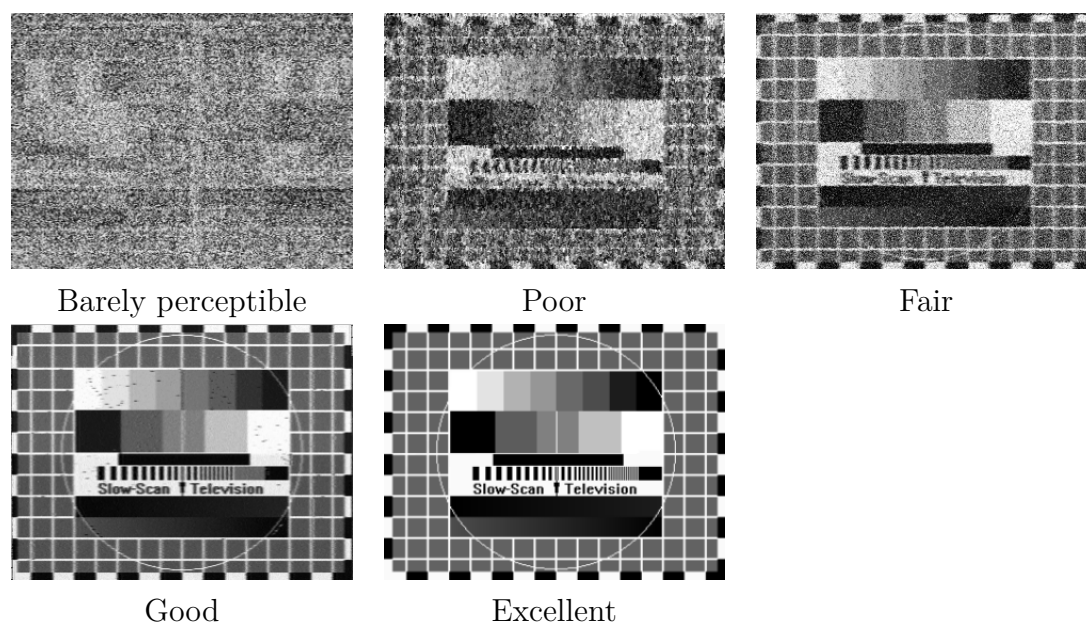

Figure 8.2: Picture quality reporting system.

8.2 SSTV not only for hams

The SSTV found application in other sectors in the past, mainly due to commercial production equipment destined for amateurs, and image transfer by phone.

Perhaps the most notable applications is the use of SSTV to monitor active Volcano [20]. U.S. Geological Survey installed in September 1987 sensing camera and FM radio transceiver for observation of volcanic activity on Mount St. Helena.

SSTV was used for remote medical applications during eighties, e.g. transfer of radiologic pictures over phone lines and over satellite narrow band communication channels.

Often repeated mistake is that NASA has used the same system as amateurs for the SSTV transmissions from space in Apollo mission and that the first images from the Moon were transmitted in same way as amateur slow-scan TV. An NASA system for video transmission is different, but their engineers also named it *slow-scan TV*, but it transmitted images at rate 10 frames per second with 320 lines. The conversion to a normal television broadcast was made by optical path, the television camera panned SSTV monitor for broadcast to millions of households.

The Amateur SSTV fly to space later, when SSTV images were sent from space shuttle in SAREX missions or from orbital stations Mir and ISS. These broadcasts were received by many hams over the World.

8.3 Diplomas and QSL cards

A tangible confirmation of ham radio contact is a QSL card, although after finished QSO you may have few saved pictures on your hard drive as a memory of the contact. But QSL cards still remains as traditional contact confirmation. Also, list of confirmed QSOs (those you've obtained QSL cards) must be also accompanied for obtaining a number of ham radio diplomas. So the picture of QSL has not same value as real QSL card.

In addition to diplomas issued directly only for SSTV contacts, the diplomas like WAS, WAC, ADXA, CQ DX Award and many more can be obtained with indication of used communication mode and some additional variants like QRP.

There are few diplomas for exclusive two-way QSO using slow-scan television listed bellow.

8.3.1 IVCA DX Achievement Award DXAA

The award is issued to amateurs and listeners for two-way SSTV contact/reception with 50 countries from DXCC list. Additional stickers are for every more 25 countries.

8.3.2 DANISH DX SSTV AWARD

The award can be obtained by radio amateurs and listeners for confirmed contacts with 50 different ARRL's DXCC countries. A QSL list must contain: call, time, date, band, mode (SSTV) and country and confirmed by two licensed amateurs and signed by applicant. All bands legally used in applicant's country are accepted, but no contacts via repeaters. It is possible to get additional stickers for contacts with 100 countries and 1 OZ station (silver), 150+2 (gold) and 200 (diamant).

The fee for basic award is \$8 or €10.

Award manager: *S.K.Mogensen OZ6SM, Rundhøjvej 8, DK 7970 Redsted, Danmark*, email: oz6sm@nypost.dk.

<http://www.ddxg.dk/awards/sstvaward.htm>

8.3.3 Russian SSTV Award

This award is sponsored by the CRC of Krenkelya and the Moscow section SSTV to popularize the use of SSTV in Russia and other countries of the CIS. Earn 75 points by contacting Russian and CIS stations on the SSTV mode on or after 1st March

1998. Contacts with members of the Moscow SSTV is valued by 3 points and one point for contacts with CIS countries or stations not members of the Moscow SSTV 1.

Send GCR list and fee of \$5, 10 IRC or equivalent to: *Verigin Dmitriy Andreevich, Lyubertsy, Moscovskaya oblast, Novaya street, 10-48, 140002, Russia*, email: ra3ahq@online.ru

<http://olympia.fortunecity.com/bruno/544/award/msstvs/rusaward.html>

8.4 Contests

Contest	Date
DARC SSTV Contest	3 rd weekend in March
Russian SSTV Contest	2 nd Saturday in April
NVCG SSTV Contest	2 nd week of July
Danish SSTV Contest	1 st weekend in May
DARC HF-FAX-Contest	3 rd weekend in August
JASTA SSTV Activity	from 1 st to 31 st August
Ukrainian SSTV Contest	1 st Saturday in December

Table 8.3: none

8.4.1 DARC SSTV Contest

It takes place the 3rd weekend in March, begins at 12:00 UTC on Saturday and ends at 12:00 UTC on Sunday. Competing has categories operator and SWL, on the bands 3.5 to 28 MHz. Transmit RSV and the number of QSOs beginning with 001, each QSO is valued by a point. Multipliers are WAE/DXCC countries, W, VE and JA districts. Logs should be sent within 4 weeks after the contest at: *Werner Ludwig DF5BX, Post Box 1270, D-49110 Georgsmarienshuetten, Germany*, email: df5bx@darcc.de.

8.4.2 Russian SSTV Contest

Takes place in 2nd Saturday in April from 00:00 MSK to 24:00 MSK (UTC = MSK - 3). Bands: 80, 40, 20, 15, 10, 6, 2 m. There are several categories: A. Multi-operators,

all bands; B. One operator, all bands (legal in Russia); C. One operator, all bands; D. One operator, one band; E. listener. A CQ image should contain CQ RUSTEST. Transmit RSV and the number of QSOs beginning with 001, Russian stations transmit RSV, zone and number of QSOs. Scoring: 6 points for each QSO, plus 2 points for QSO with MsstvS member, additional points for QSO with station from MsstvS scoring list. Final score: total sum of points plus additional points. Send log separately for each band, must include band, date, time in UTC, call sign messages sent and received. Stations with multiple operators must deliver list of names and signatures for all operators. The log send to 24th April. Organizer: *Russian SSTV Contest Manager Krenkel of CRC Russia, P.O. Box 88, Moscow, Russia.*

8.4.3 NVCG SSTV Contest

The contest is organized by Nishi Nippon Visual Communication Group and takes up 9 days in July. Score is 2 points for two-way SSTV QSO with NVCG member (they used “M” letter in report, e.g. 595M), and 1 point for another QSO. Only one QSO with same station is counted regardless of band. The multiplier is the total number of different prefixes. Send log to *Susumu Tokuyasu JA6GN, 3-1-6 Jyousei Sawaraku, Fukuoka 814-0003, Japan* or email: `sstv-contest-nvcg@wak.bbiq.jp`.

8.4.4 Danish SSTV Contest

The contest is organized by Danish SSTV Group. Takes place first weekend in May, from Saturday 00:00 UTC to Sunday 24:00 UTC. Bands: 80, 40, 20, 15, 10, 6, 2 m. Score: 2 points for every DXCC country, 1 point for contact and bonus 1 point for contact with Danish station. It is possible to make QSO with same station on different band. The stations on 1st to 5th place will receive certificates. Mail logs to: *Carl Emkjer, Soborghus Park 8, DK 2860 Soborg, Denmark.*

8.4.5 JASTA SSTV Activity

Takes place in August from 1st 00:00 UTC to 31st 24:00 UTC on 3.5MHz band and all upper bands. There are two categories: “J” – Japanese stations; “S” – all stations operating outside of Japan. Exchange the usual RSV and number of QSO starting with 001. Regardless of bands used a station may only be contacted only once each UTC day. The points for QSOs depend on band: 1 point 3.5–28 MHz, 2 points 50–430 MHz and 3 point for 1200 MHz and upper bands. Multipliers are districts JA1 to JA0, DXCC countries and working days (max. 10). Prefixes 7K to 7N are all JA1 districts. Contest manager: *Yoshikazu Tanabe JA3WZT/1, 905-8, Shimotaniganuki, IRUMA, SAITAMA, 358 Japan*, send logs in TXT format to `ja3wzt@mue.biglobe.ne.jp`.

<http://homepage3.nifty.com/jasta/>

8.4.6 Ukrainian SSTV Contest

Takes place in first Saturday in December, from 12:00 UTC to Sunday 12:00 UTC. Bands: 80, 40, 20, 15 and 10 m. There are contest categories: A. One operator; B. One operator, one band; C. Multiple operators; F. listeners. The CQ picture should contain text **CQ UKR Contest**. Exchange report RSV and number from 001. Ukrainian stations send two-letter region code too. The score is 1 point for QSO with same country station, 2 points for same continent QSO, 3 points for QSO with other continent, QSO with Ukrainian station is for 10 points. Multipliers are DXCC and WAE countries and Ukrainian district for each band. The score is counted separately for Ukrainian and foreign stations. Logs send in usual form for each band to organizer: *UKR SSTV CONTEST, P. O. Box 10, Kerch, 98300 Ukraine*.

8.5 SSTV repeaters

An SSTV repeater is radio station for relaying of SSTV signals. A typical repeater is equipped with HF or VHF transceiver and computer with sound card. A software must have an option to work as repeater.

SSTV repeaters are used by amateur radio operators for exchanging pictures. If two stations can not copy each other, they can still communicate through a repeater.

To activate repeater send the activation tone of frequency 1750 Hz, when the repeater is activated, it's send -- (K) in morse code. The station must start sending a picture in approximately 10 seconds. After reception the received image is transmitted on the repeater's operation frequency.

Repeaters should operate in common SSTV modes, but it depends on the software used (MMSSTV, JVComm32, MSCAN). Some repeater are not activated by audio tone, but instead by the SSTV vertical synchronization signal.

Some repeaters works also as beacon and sends periodically random images with identification and timestamp.

8.5.1 HF and 50 MHz repeater list

8.6 Ham radio satellites and space broadcast

For SSTV operations can be used a linear relay installed on some of the amateur radio satellites. Amateur satellites orbiting the Earth for elliptical orbits. *Linear*

Freq.	Call	QTH	Activation	Power	Note
3,720	F5ZPJ	Haute Saône, JN27UR	image		linked with repeater on 144,525 MHz
14,236	VK3DNH	Rochester			Active 24 hours
14,239	VK2ISP	Coogee, New South Wales			Aktive 24 hours
21,349	VK6ET	Brackenridge, approx. 20 km north from Brisbane		50–100 W	QRV 22:00-08:00 UTC
28,660	GI4GTY	Lisburn	image		
28,688	HB9AC	Eighental, Lucerne JN47CA	1750 Hz		Linked with repeater on 144,825 MHz FM.
28,690	K3ASI	North Carolina	1750 Hz	45 W	Aktive 24 hours, beacon every 15-20 minut.
28,700	ON4VRB	Heist o/d Berg	1750 Hz		Linked with repeater on 433,925 MHz.
28,750	ON0DTG	Doornik			
28,900	EA8EE				
50,500	F6IKY	Haute Savoie (700 m)			USB
50,510	OZ6STV	Copenhagen, JO65ER	1750 Hz	60 W	Beacon every 30 minutes.

Table 8.4: none

relays (transponder) performs retransmission of the wider frequency range, typically 50 to 250 kHz. So the satellite then transmits all the signals (CW, SSB, ...) received on the band (not like the FM ground FM repeater to allow operations to only one user). If you have station equipped for satellite communication you can try also SSTV.

You can also monitor experimental SSTV transmission from International Space Station and receive SSTV signals with your 2m FM transceiver, see **section 8.6.3**.

Space communications provides few problems. The first of these is *Doppler effect*, named after the famous Austrian physicist, which reflects changes in wavelength of the signal between the observer and the signal source on a moving object. In practice this means that if the satellite is closer to your position the signal appears to have a shorter wavelength and the receiver must tune to higher frequencies, when the satellite is moving away it's exactly the opposite.

Other problem is variance of signal quality due to satellite rotation, that causes a leakage signal. The antenna with circular polarization should be used for these purposes.

Frequency band	Designator
21–30 MHz	H
144–146 MHz	V
435–438 MHz	U
1.26–1.27 GHz	L
2.40–2.45 GHz	S
5.6 GHz	C
10.4, GHz	X
24 GHz	K
47 GHz	R

Table 8.5: Uplink and downlink bands.

Frequency bands of linear relays are shown in **table 8.5**. These frequencies describe satellite relay operating modes. It is fixed by satellite design on chosen by control center. The designator like U/V describes uplink 435–438 MHz (U) and downlink 144–146 MHz (V). E. g. *Fuji-OSCAR 29 (FO-29)* operates in mode V/U, the uplink is in the range of 146,000 to 145,900 kHz CW/LSB and downlink 435.800 to 435.900 kHz CW/USB. Note that relay inverts signal frequency (LSB to USB). Other satellites carry on board the single-channel FM transmitter, such as the popular AO-27 with uplink 145,850 kHz FM and downlink 436,795 kHz FM.

It is required to monitor own SSTV signals on downlink, when working on linear relays. Some sound cards support full duplex operation, so the computer can also send and receive in same time. Then the operator changes the transmit frequency so that receiving frequency appears to be same, just follow the position of the syncs on spectroscopy. This way compensates the Doppler effect.

During years there were many satellites used for SSTV operations, like FO-29, VUSat OSCAR 52 (beacon 145,936 kHz), AO-51, SO-50, etc. But satellite lifetime is limited, in time board batteries getting weaker and ground control center switching off transponder and waits for their recharge from solar panels. You can find actual informations and satellite statuses on website of Amateur Satellite Corporation, i. e. AMSAT.

<http://www.amsat.org>

8.6.1 SSTV from Mir station

Days of the orbital station Mir are already numbered, but as a reminder there is description of the experiences with SSTV transmission, which took place in Manned Amateur Radio Experiment (MAREX) in late 1998 and 1999.

The project anticipated broadcast on the frequency 437.975 MHz, but due to some problems with antenna systems we have to make do with only the occasional broadcast on the two meters band.

Transmit frequency was 145,985 MHz FM \pm Dopplers's frequency shift. The packet radio AX.25 BBS R0MIR-1 was normally operating on this channel.

Station at low orbit passed 5 times a day over Europe at approximately 1.5 hours intervals.

The Robot 36 Color mode was chosen for SSTV transmission. The pictures were sent in 2 minutes interval, so during one orbit you could copy transmission for 10 minutes and receive about 5 pictures. Each picture was introduced by morse code `-././/.-./-----/--/./.-.` DE ROMIR and then transmitted.



Figure 8.3: SSTV picture from station R0MIR.

I found, that there was about ± 5 kHz frequency change caused by Doppler's effect. So during orbit it is good to tune receiver, it's ideal to use transceiver with continuous FM tuning (I use FT-767). When Mir approached the horizon and it was coming near the tuning frequency was 145,990 MHz and when it was fly away the frequency is lower, i.e. 145,980 MHz. Some transceivers measure discrimination of FM signal, so it is very easy to tune on carrier frequency.

Designers of SSTV station chose Robot 36 Color mode, it's not resistant to noise, so when there is great shift from center carrier frequency the signal used to be noisy and picture quality is distorted. The frequency of AFSK signal transmitted through FM channel doesn't change, so the color distortion, known from SSB transmission, doesn't appear.

The antenna of my station for Mir monitoring was 3 element yagi with vertical polarization (normally used for ground repeaters). I directed it to azimuth, where Mir was nearest to my site. Later I tried to direct rotator during orbit, the azimuth and time I had computed and it was possible also to direct yagi by signal strength displayed on transceiver S-metr.

8.6.2 SuitSat

In early 2006 (originally planned to release about 3 months earlier) were from the International Space Station (ISS) launched the satellite in an unusual project *ARISS* (*Amateur Radio on the International Space Station*). The satellite was named *SuitSat* (the code name is the AMSAT-OSCAR-54 [AO-54]). And its name describes the full implementation of the satellite, because on-board equipment was built into expired Russian space suit (type Orlan).

The transceiver Kenwood TH-K2 was tuned to frequency 145,990 MHz and its power source was realized from the batteries, so its lifetime was limited to a few weeks.

The satellite was programmed to broadcast a voice message, prepared SSTV image (in Robot 36 Color) and telemetry data that contained information such as measured temperature and radiation. The entire broadcast session lasts approximately 9 minutes.

After few hours after SuitSat's release, ham radio operators reported only weak signals and was monitored only couple of days. Probably due to low temperature the on-board batteries lost capacity.

The SuitSat AO-54 should starts the series of similar experiments, like project Arissat-1.

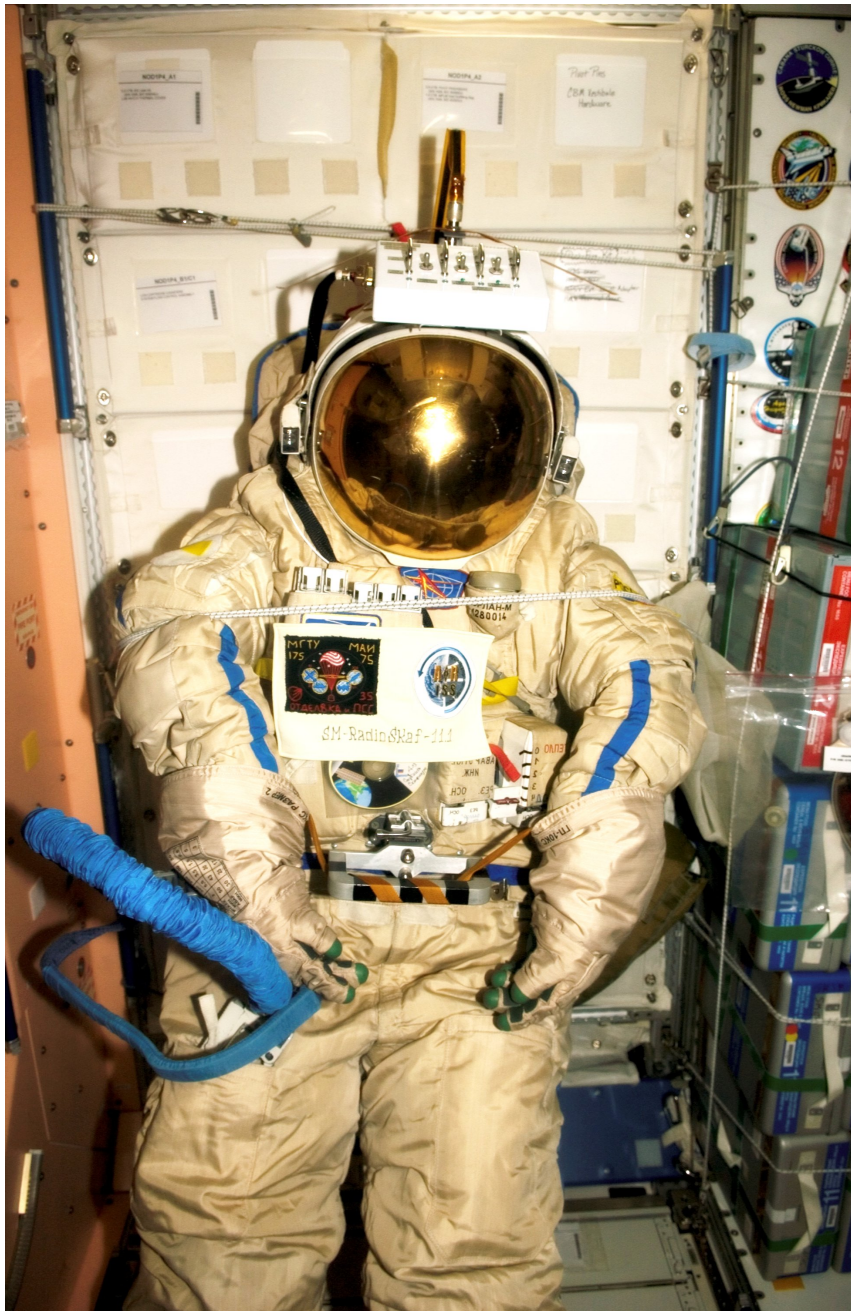

Figure 8.4: SuitSat built into the spacesuit (NASA, source cat. no. ISS012E15666).

8.6.3 Amateur Radio on the International Space Station

The successor of popular ham radio projects on Mir is the project *ARISS*. The targets are to build SSTV beacon/repeater, packet radio BBS and world-wide propagation

of ham radio hobby.

The SSTV equipment on ISS consist of *SpaceCam 1* software (from ChromaPix authors). It runs on normal PC, support video digitizer and it can works as repeater or transmits slide-show pictures from station cameras. The SpaceCam transmit pictures every 120 seconds in Robot Color 36 mode and every picture is started with morse identification (R0ISS, NA1SS).

The following frequencies are currently used:

- ▷ **Voice and Packet Downlink:** 145.800 MHz (Worldwide)
- ▷ **Voice Uplink:** 144.490 MHz for Regions 2 and 3 (The Americas, and the Pacific)
- ▷ **Voice Uplink:** 145.200 MHz for Region 1 (Europe, Central Asia and Africa)
- ▷ **Packet Uplink:** 145.990 MHz (Worldwide)
- ▷ **Crossband FM repeater downlink:** 145.800 MHz (Worldwide)
- ▷ **Crossband FM repeater uplink:** 437.800 MHz (Worldwide)
- ▷ **Worldwide SSTV downlink:** 145.800 MHz

For latest ARISS news and status check the website:

<http://www.ariss.org>

9

Introduction to digital slow-scan TV

The development of computers and new opportunities, which gives us the use of powerful processors and sound cards modems have resulted in the design of new communication modes. One of these modes is the digital slow-scan television (DSSTV), which allows transmission of images without any loss of quality.

We have two choices for digital image transmission. The first system is *RDFT* – *Redundant Data File Transfer*, which is the result of several years of creative efforts of Barry Sanderson, KB9VAK and a group of ham radio enthusiasts.

The second system is called *Digital Radio Mondiale (DRM)*. It's open standard for digital broadcast on short waves. It was developed by DRM Consortium and was standardized by organizations ITU, IEC and ETSI. The DRM system is used mainly by short-wave broadcast stations and its modification for ham radio purposes is called *HamDRM*.

It is possible to use these modes also for transfer of any types of files (text, sounds, software,...) instead of images.

The difference between analog and digital SSTV is huge. There are used entirely different modulation principles and essentially some files in JPEG, JPEG200, PNG, etc. formats are sent. Also the error correction and detection is implemented using Reed-Solomon code.

The result is, that image is transferred without any distortion (means transfer distortion, the images should be distorted due to loss compression techniques, but you can control the degree of it). There is no constrain in image resolution, it is given by image file parameters. Only constrain is the bandwidth of SSB channel and the resulting maximum data rate and the time required for transmission.

There are also bigger requirements for stations equipment in comparison with classic SSTV. You need better computer, at least 1GHz CPU and 256 MB RAM. In your ham-shack you can use without any problems an oldish computer (e.g. Pentium 150 MHz) for digital modes like RTTY or PSK, packet radio and analog SSTV, but algorithms of signal processing for DSSTV is so complex that a slow 150MHz Pentium would not be able to process signals in real-time.

Also, there are increased requirements on the transceiver used. Used modulation techniques use the maximal width of the communication channel and SSB transceiver without the linear range of SSB channel isn't usable for DSSTV. Of course, there must be switched off any additional signal and modulation filters (speech processor, equalizer,...).

Sound card interfacing is same as for classic SSTV, the connection between TRX and sound card is enough. Output level of sound card should be about $\frac{1}{3}$ of maximum (switch off software AGC). When signal is overexcited, the intermodulation causes disproportionately large signal and distortion and the signal cannot be decoded. A peak power with 100W transceiver is about 20–25 W.

9.1 Digital communication basics

Before I describe the transmission systems we look at some important concepts of data communication. What interests us most is the speed which is possible to transmit information – we distinguish between the speed of transmission and modulation:

Symbol rate v_m – express the number of changes a of carrier signal per second. It is measured in unit *Baud (Bd)* or *Symbols per second (S/s)*. Symbol rate does not say anything about how much information transmitted on signal carrier.

$$v_m = 1/a \quad [\text{Bd}]$$

Bit rate v_p – indicates the amount of information transferred per second. It is expressed in *bits per second (bps)*. Bit rate says nothing about how fast the signal carrier changes.

$$v_p = v_m \cdot \log_2 m \quad [\text{bps}],$$

where m is the number of modulation states.

We know from previous chapters that an important feature of communication channel is a limited bandwidth B . Relation between symbol rate and bandwidth shows *Nyquist rate*:

$$v_m = 2 \cdot B.$$

Ideally, the symbol rate should be twice the bandwidth. Substituting the formula for the symbol rate, we get:

$$v_p = 2 \cdot B \cdot \log_2 m.$$

Let's look on the relationship between symbol rate and bit rate, because these two term are often use interchangeably. E.g. packet radio on VHF has bit rate 1200 bps and the used modulation is AFSK (Audio Frequency-Shift Keying). Frequencies carrying information are two – 2200 Hz for mark (log. 1) and 1200 Hz for space (log. 0). We know $v_p = 1200$ bps, $m = 2$, so symbol rate is equal to bit rate:

$$v_m = \frac{v_p}{\log_2 m} = \frac{1\ 200}{\log_2 2} \text{ Bd} = 1\ 200 \text{ Bd.}$$

A packet radio is based on ITU-T V.23 specification for telephone modems, where bandwidth is limited to about 4 kHz. Modern dial-up modems, but have a much higher bit rates, up to 56 kbps and the bandwidth remains 4 kHz. How is that possible?

It's possible through the used advanced modulation, which has more modulation states m then two. For example, modems based on V.32 specification can use bit rate up to 9,600 bps. There is used *QAM (Quadrature Amplitude Modulation)*, which in case of QAM-16 has 16 states per one modulation symbol. The symbol rate in this case is:

$$v_m = \frac{v_p}{\log_2 m} = \frac{9\ 600}{\log_2 16} \text{ Bd} = 2\ 400 \text{ Bd.}$$

One could think that it's possible to reach any speed because of improved modulation and more states. Unfortunately not, because there are stark physical limits. Maximal channel capacity C (bit rate) in bps is given by *Shannon's law*, which depends on bandwidth B (Hz) and channel parameters signal/noise ratio S/N (dB):

$$C = B \cdot \log_2 \left(1 + \frac{S}{N} \right).$$

As we can see the maximum bit rate speed is not affected by the used technology, but the bandwidth B and signal/noise ratio (SNR), which cannot be changed. SNR is given in decibels (dB) and describes the ratio of a signal power to a noise power of a processed bandwidth.

9.2 Error detection and correction

The error detection codes are used as a check of error-free transmission. The idea is based on some extra data (redundancy) added to a message. The redundancy is generated from some input data on a transmission side (*FEC – Forward Error Correction*) and on a reception side it is possible to check if the data was transferred without error. An used code may have also ability for an error correction,

so data affected during transmission can be repaired on reception side without re-transmission. There are several error detection codes, e.g. even parity described in **chapter 3.6.2**.

The codes have several parameters. First is the bit length of information k , which we want to encode and the length of codeword n . The difference $r = n - k$ is the length of redundancy data. Redundancy does not transfer any information, but it is only used for error detection and possibly correction. The ratio of the number of information symbols to the number of all symbols

$$R = \frac{k}{n} = \frac{n - r}{n}$$

expresses *information ratio*. In practice, we require that redundancy is minimized.

The ability of the code, how many errors should be detected or corrected is given by *Hamming distance*. It is determined as the number of different symbols of two different codewords. The most important is minimal Hamming distance d of all arbitrary codewords. E.g. Hamming distance of 0101000 and 0111001 is $d = 2$. The errors during transmission cause replacement of one symbol to another and Hamming distance indicates how many replacements may occur to change the codeword to another valid codeword. It is advantageous to have a Hamming distance of codewords larger as possible. So if you want code that reveals just one error bit, the minimum distance must be $d = 2$. Block code with minimal distance d *detects* all t -multiple errors for $t < d$. If there is too much errors that $t = d$ or $t > d$ there should be created a new valid word, so the error cannot be detected. The code can correct errors for larger d , if for error word is found a valid codeword with smaller Hamming distance between error and valid word. The block code *corrects* all t -multiple error when

$$t < \frac{d}{2}.$$

These findings can be demonstrated on a simple case of 2-bit code secured with even parity. Two-bit code can have a total of 4 words of information, and a redundant bit will be added, so that the number of log. ones in the codeword will be even.

The resulting code words have 3 bits and there are $2^3 = 8$ different bit words (code words are bold):

The minimum distance d of our parity code is equal to 2, so the code is able to detect just one error. When word 011 is sent and 010 is received we know that there is an error. If there are two errors and 011 changes to 000, then there is a word that belongs to a set of codewords and error isn't detected.

In the following sections are described some commonly used error-detection and correction codes.

Information word	Parity	Codeword
00	0	000
01	1	011
10	1	101
11	0	110

Table 9.1: none

000	001	010	011
100	101	110	111

Table 9.2: none

9.2.1 Cyclic redundancy check

The *CRC* is commonly used code. The *systematic cyclic code*, adds a fixed-length check (*checksum*) value to message. The checksum is used for error detection.

CRC calculation is performed on block or section of data is stored in memory, the k -bit sequence is represented as a polynomial $G(x)$. This is polynomial is divided by generating polynomial $P(x)$ in arithmetic modulo 2. The result is polynomial $Q(x)$ and the remainder after dividing $R(x)$. The remainder $R(x)$ is added to input data and transmitted in message.

On the reception side the division with $P(x)$ is computed again and new remainder $R'(x)$ is compared with transferred remainder $R(x)$. If both values are the same transfer went without error, if not at least one bit was transferred incorrectly.

9.2.2 Hamming code

In the area of data communications (e.g. TV teletext) is sometimes used *Hamming code*, which can detect up to two errors and in the case of a one error it is able to determine at what point of codeword error occurred and it can fix received bits.

Basically, it uses for its purposes even parity. While the parity bits are in the final codeword positioned at the serial number is equal to the square of 2 (1., 2., 4., 8.,...). Under the control bit position is then selected certain sequence of information words, which is used to determine the value of control bit.

9.2.3 Reed-Solomon code

Hamming code works well in environments where errors occur randomly and their incidence is low (e.g. in computer memory, which can detect a erroneous bit to 100 million). But even if that failure causes a greater number of adjacent bits are corrupted (*burst error*), the Hamming code is useless. In the field of radio transmission, where the signal is often affected by atmospheric disturbances, fade outs and interference, then errors occur in clusters. This means that close to the incorrect symbol are other symbols incorrect too. For burst error correction is applied *Reed-Solomon code (RS)*.

RS codes are the most widely used codes for detection and error correction. They are characterized by having the largest possible minimum distance, and compared to the previous code will not correct the individual bits, but all symbols. RS code have found application in the number of areas – is used by NASA for space communications, protects data on CD-ROMs and DVDs and is also used for terrestrial transmission of HDTV or in the data modems for the cable television networks.

Like the CRC the RS code is systematic. For its generation are used the algebraic calculations of Galois field.

Parameters of the $RS(n, k)$ are defined as follows:

- ▷ s – number of bits in one informational symbol,
- ▷ k – number of s -bit symbols in data block,
- ▷ n – number of bits in codeword.

$RS(n, k)$ is able to correct $\frac{n-k}{2}$ errors in k information symbols. Often used code is $RS(255, 223)$, it uses 223 8-bit symbols for creation of 255 symbols of codeword. There is 32 symbols dedicated for error correction. $RS(255, 223)$ is able to repair up to 16 erroneous 8-bit symbols.

9.3 Data compression

The image with resolution 320×240 with a color depth of 16 million colors (256^3) takes 230,400 Bytes ($320 \times 240 \times 3$) without compression. This file would be transmitted fortyone minutes by RDFT with speed 92 Bytes per second! This time is really scary in comparison with analog SSTV. It is really necessary to reduce the file size and reduce the time required for transmission.

The *data compression* is widely used in such cases, where the data capacity of communication channels or storage media and memory is limited.

The compression is the process where the physical data block size is reduces to a certain level. Input data is compressed using the compression algorithm and

then stored on media or transmitted via communication channel. The data are decompressed in its original form, when a media is read or a signal received.

One of the important parameters of compression algorithms is *lossy*. While the programs or text must be stored in perfect form, but in case of sound, images or animations we can settle with the omission of certain details, then we're talking about lossy compression method.

9.3.1 Information entropy

When Claude E. Shannon was engaged in applied mathematic of communication theory during 1940s, he started with definition of informational value of message content. The message which is repeated often is less informative than the message, which occurs sporadically. So, the often repeated message is more likely than the unique. The probability in mathematic is expressed by real numbers in range from 0 (for a completely unlikely events) to 1 (for the phenomena that occur surely). Shannon defined the amount of information $I(x_i)$ for the message x_i with the probability of occurrence $p(x_i)$ as follows:

$$I(x_i) = -\log_2 p(x_i).$$

The graph of negative logarithm see on **fig. 9.1** – if the message content is less likely that its information value is higher.

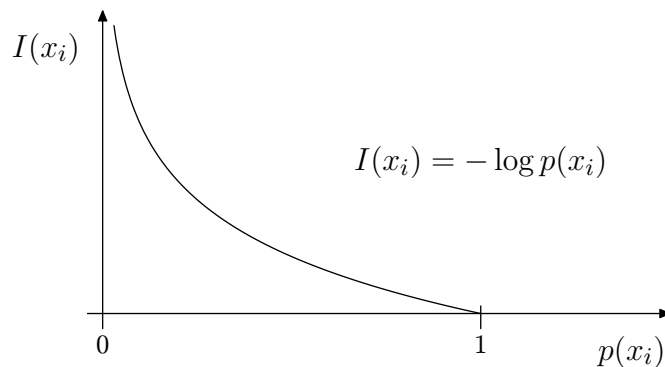

Figure 9.1: The relation between information content $I(x_i)$ and its probability $p(x_i)$.

Information entropy H is defined as *average rate of information value* $I(x_i)$:

$$H = \sum_{i=1}^N p(x_i)I(x_i) = -\sum_{i=1}^N p(x_i) \log_2 p(x_i) \quad [\text{bit}]$$

We show the entropy meaning in example. We need to transfer messages a_1, a_2, \dots, a_8 and probability of their occurrence is same: $p_i = 1/8 = 0,125$. The entropy of source is

$$H = - \sum_{i=1}^8 p(a_i) \log_2 p(x_i) = - \left(8 \cdot \frac{1}{8} \log_2 \frac{1}{8} \right) = 3 \text{ bits.}$$

The observed entropy determines how the message content can be encoded for data transmission. The length of message in bits is greater then or equal to the entropy, without loss of information. So the message can be encoded as word of 3bit length: 000, 001, 010, ... Maximum entropy is reached when the probability of occurrence of each message is the same.

But the messages have often different probabilities in many cases. In this example we need to transfer messages a_1, a_2, \dots, a_7 . Their probabilities are $p(a_1) = 0.235$, $p(a_2) = 0.206$, $p(a_3) = 0.176$, $p(a_4) = 0.147$, $p(a_5) = 0.118$, $p(a_6) = 0.059$, $p(a_7) = 0.029$, $p(a_8) = 0.029$. Entropy of source is

$$\begin{aligned} H &= - \sum_{i=1}^7 p(a_i) \log_2 p(a_i) = \\ &= -(0.235 \cdot (-2.09) + 0.206 \cdot (-2.28) + 0.176 \cdot (-2.50) + 0.147 \cdot (-2.76) + \\ &0.118 \cdot (-3.08) + 0.059 \cdot (-4.08) + 0.029 \cdot (-5.08) + 0.029 \cdot (-5.08)) \text{ bits} \\ H &\approx -2.712 \text{ bits} \end{aligned}$$

We see, that the entropy of source is lower and because data bits are not divisible, it is necessary to encode the message again to the words of length 3. But suspect that such an encoding is no longer optimal. There is the idea to encode frequently occurring words as the message of the shorter length. This idea was well-counseled by David A. Huffman, the Shannon's student.

9.3.2 Huffman coding

We can show an example of Huffman coding construction. The message we are going to encode is following:

THE SHELLS SHE SELLS ARE SEASHELLS

This message contains 8 symbols (S, E, L, " ", H, A, T, R). The message can be expressed with code words of 3bit length. Its whole length is $3 \cdot 34 = 102$ bits.

For Huffman coding we need to determine number of each symbol and their probabilities.

There is used *binary tree*, it is a data structure often used in programming. The symbols are sorted by their frequency and then each symbol represents a tree leaf, and its weight is given by symbol occurrence. In first step join two leaves with the

S	E	L		H	A	T	R
8×	7×	6×	5×	4×	2×	1×	1×
0.235	0.206	0.176	0.147	0.118	0.059	0.029	0.029

Table 9.3: none

lowest weight, in our case T and R and create a node. The node weight is sum of weights T and R. In the next step join leaves or nodes with the lowest weight and proceed as long as there is only one node (the root of binary tree).

Now, go from the root toward leaves by the edges and each edge label by 0 or 1, if the edge goes up or down (in tree terminology to left or right subtree). The constructed tree with labeled edges see on **fig 9.2**. To find the code of each symbol pass all ways from the root towards the leaves. The path going along the edges of 0, 0 ends in S, the path going along 1, 1, 1, 0 ends in A.

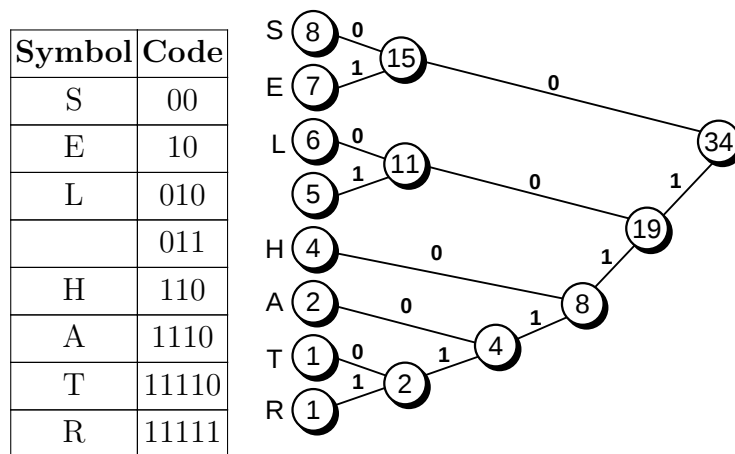

Figure 9.2: The results of Huffman encoding.

We see, that more frequent symbols with high probability of occurrence have shorter code than sporadic symbols. Our message after encoding:

```
1111011001101001100110010000101
0011001101000110010000101111011
1110110100011110001100110010000
```

The message length was reduced from 102 to 93 bits. For decoding the binary tree **on 9.2** can be used again. We will start in the root and go along edges 1, 1, 1, 1, 0 until we arrive to leaf, here symbol T, then we return to the root and go along 1, 1, 0 and we arrive to leaf H. By this way we continue until the whole message

is decoded. Because Huffman coding is has unique *prefixes* for each code, and this prefixes is not start of another codeword the decoding can not do mistake.

Other compression algorithms using dictionary methods. These methods are based on fact that some words in the input file occur more frequently. Repeating words are stored in the dictionary. These words are replaced with their corresponding code words in output file. Among the representatives of this type of compression belongs *LZW (Lempel-Ziv-Welch)* as used in the ZIP compression or GIF or a variant of the TIFF formats.

9.3.3 Lossless data compression

Many applications needs for their requirements that data aren't impaired if they are compressed. E.g. for binary programs and data. Lossless compression has its justification in the field of computer graphics and image storage too. Lossy compression fits on "nature images" and photographs, but when it is used on a computer-generated graphics such as diagrams and charts, the image distortion is more noticeable on sharp edges and color gradients, even at low compress ratio (see [section 9.3.4.3](#)).

Many compression algorithms were developed for lossless compression. A simple algorithm is for example *Run Length Encoding (RLE)*. This algorithm stores repeated bytes as their value and number. E.g. AB AB AB CD EF EF EF EF EF is stored as 03 AB 01 CD 05 EF, so instead of 9 bytes should be only 6 stored.

Other types of algorithms are based on statistical methods. Before or during the compression process the algorithm determines the relative representations of elements of the file, and those repeated frequently are expressed as a short code word. Such algorithm is the Huffman coding described above. Also, Morse code is one of those codes, frequently recurring characters such as E (.), A (.-), I (..) have assigned shorter codes and the less frequent, such as H (...), J (.-.-), F (..-) longer codes.

9.3.3.1 Portable Network Graphics

The PNG is appropriate graphics format with lossless compression. PNG was created to replace the outdated GIF format. PNG is not limited to a palette of 256 colors like GIF and allows to set a continuous level of transparency (*alpha-channel*) compared to GIF, which has the option to choose only two levels (yes or no transparency). If you want to save the lossless image just choose PNG.

The algorithm used in PNG is called *deflate*. This method is enhanced in some ways, the image lines are firstly processed by filter, which tries to find a similar neighborhood for each pixel. After processing there is a large number of data with zero value or a value close to zero (for same or similar values), so compression

algorithms finds in data areas with same value so it can shrink the length of the resulting file.

9.3.4 Lossy compression

The principle of lossy compression takes advantage of the processing equipment, in the case of the human eye it is unable to process certain information, so it actually would be an extra piece of information omitted.

A widely used method for lossy image compression format is *JPEG (Joint Photographic Experts Group)*. The JPEG is the standard established by the ISO and ITU, released in 1992 (later upgraded in 1997). A successor is upgraded format *JPEG2000*. It was developed by JPEG committee since 1995, was released in December 2000 and further revised in 2003, but it is not so widespread as its predecessor.

9.3.4.1 JPEG compression

JPEG usually does not use RGB color coding but use YCrCb, see **chapter 3.5.2**, because the human eye perceives brightness and colors with different sensitivity. The storage of YCrCb colors, mostly in the ratio 4:2:0 reduces size of file, but itself is not enough. The image is further transformed, see schema in **fig. 9.3**.

In first step the image is divided on square block of 8×8 pixels and these 64 points is transformed from spatial domain (x, y) to frequency (i, j) by discrete cosine transform. Just for completeness, as follows:

$$\text{DCT}(i, j) = \frac{1}{4} C(i) \cdot C(j) \sum_{x=0}^7 \sum_{y=0}^7 \text{pixel}(x, y) \cdot \cos \left[\frac{(2x+1)i\pi}{16} \right] \cdot \cos \left[\frac{(2y+1)j\pi}{16} \right],$$

$$\text{where } C(a) = \begin{cases} \frac{1}{\sqrt{2}} & \text{for } a = 0; \\ 1 & \text{in other cases.} \end{cases}$$

The first position $i = 0, j = 0$ holds *DC coefficient*, the mean value of the waveform for 64 values of block. The other positions contains *AC coefficients* and their value is derived from deviations between each values and DC coefficient. Basically, the DCT trying the block of 8×8 “to fit” a linear combination of shapes given by the previous formula.

Then follows a step that most affects the resulting image and a perception of the lossy compression level. The quantization is carried out by individual members of a predefined luminance quantization table (chrominance component has a different predefined table). A member of the block at position 00 is divided by a member 00

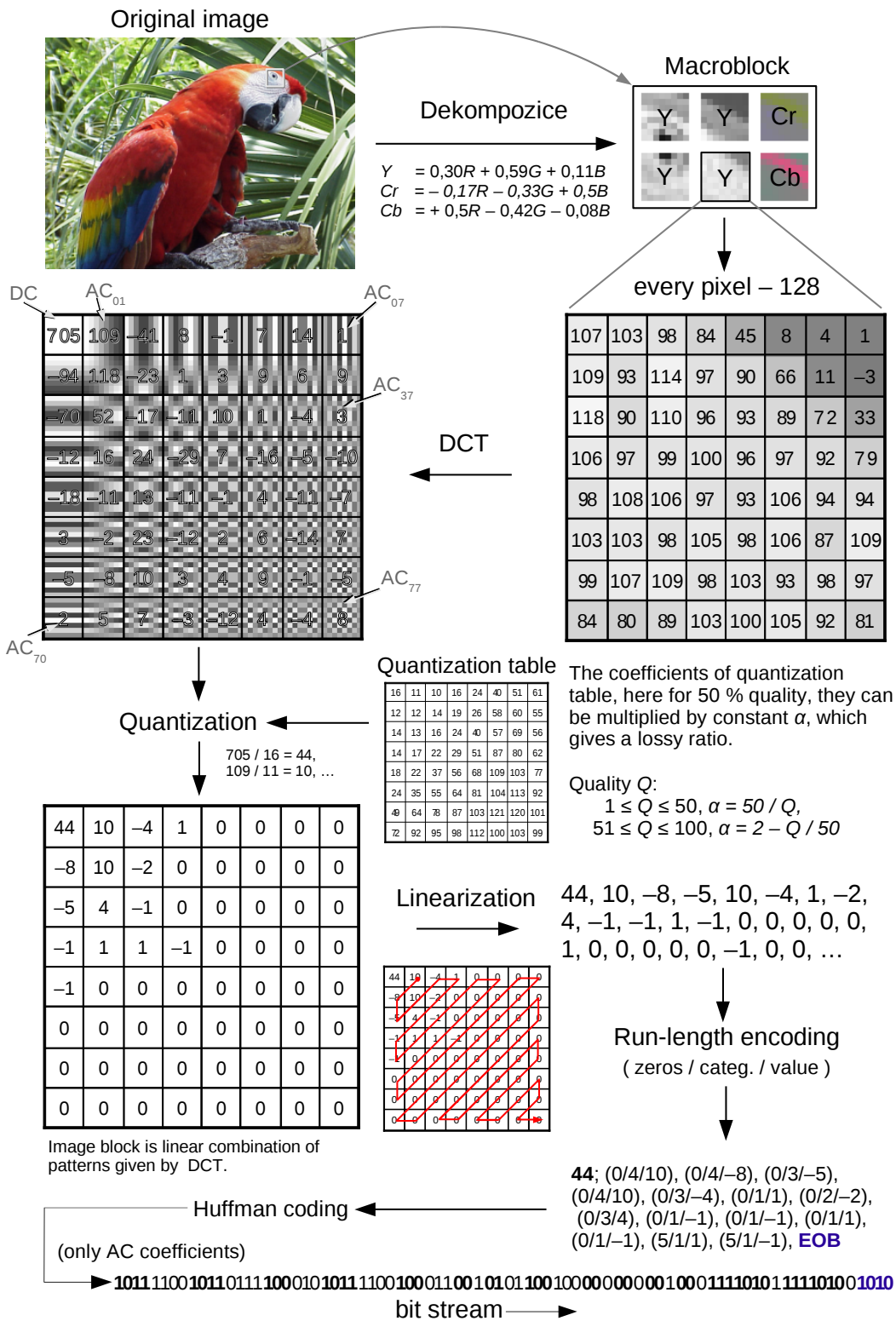

Figure 9.3: The JPEG compression for one 8x8 block of brightness.

of the quantization table and the position of the integer part of number is stored at position 00, continues 01/01, 02/02,...up to each value is divided by its corresponding coefficient. The result of this process is a square matrix, where most information is stored in the upper left corner and around the lower right corner are just zeros.

This matrix is linearized into a sequence. Thanks to “zig-zag” reading the non-zero values appear in front of the sequence and remain part is filled by unnecessary zeroes.

Then the sequence is divided into categories, the first is DC coefficient and then other values continue and for each is determined following values: (number of preceding zeros / category / intrinsic value). The redundant zeros are reduced by RLE coding and from some place are presented only zeros. The all zeros are omitted and replaced by EOB (end of block) mark. DC coefficient, brightness and chrominance values have their codings.

For AC coefficients are zeroes labeled as category 0, for other integer values their categories is given by bit length of value. For most common AC coefficients $\{-1, +1\}$ it is 1, these two values can be represented by value 0 or 1, for $\{-3, -2, +2, +3\}$ is length 2, and it is represented by $\{00, 01, 10, 11\}$, for $\{-7, \dots, -4, +4, \dots, +7\}$ is length 3, etc. The result code depends on number of preceding zeros and bit length, so 0/1 (no zero/ length 1) has 00, 0/2 01, 0/3 100, 1/1 (1 zero/length 1) 1100, 5/1 1111010, etc. The results of Huffman coding for one block see in **fig. 9.3**.

We have an option to choose the image quality for JPEG files. For quality of 75 % the distortion is not noticeable in most cases and compress ratio can be around 20 : 1 to 25 : 1. The results of different quality for image with 256×192 seen in **fig. 9.4**. You can notice little distortion for quality about 50 %, mainly in areas with sharp color gradients.

Lossy compression of JPEG is not suitable for all types of images. It is good for “natural” images, but it is problematic for computer generated graphics like schematic diagrams, 3D renders, etc., where there are many sharp color gradients. The example of bad chose of compression see in **fig. 9.6**. The file size of both images is almost same. While for lossless PNG we cannot see any distortion, in the right image stored in JPEG format with compression set to the closest file size to PNG, we see that a DCT transform cannot handle sharp edges and the bias around them makes image heavily distorted.

There is also an option for storage data in *progressive mode*. In progressive mode, in first step the DC coefficients of all image blocks are transferred, then first AC coefficients, second AC coef., etc. This allows a low detail preview after receiving only a portion of the data and during a reception more and more details are displayed. The progressive mode is very useful for slow DSSTV transfer.



Figure 9.4: The file size as result of JPEG compression loss degree.



Figure 9.5: The detail of image saved in 10% quality.

9.3.4.2 JPEG2000

When compared with original JPEG standard the new JPEG2000 has many im-

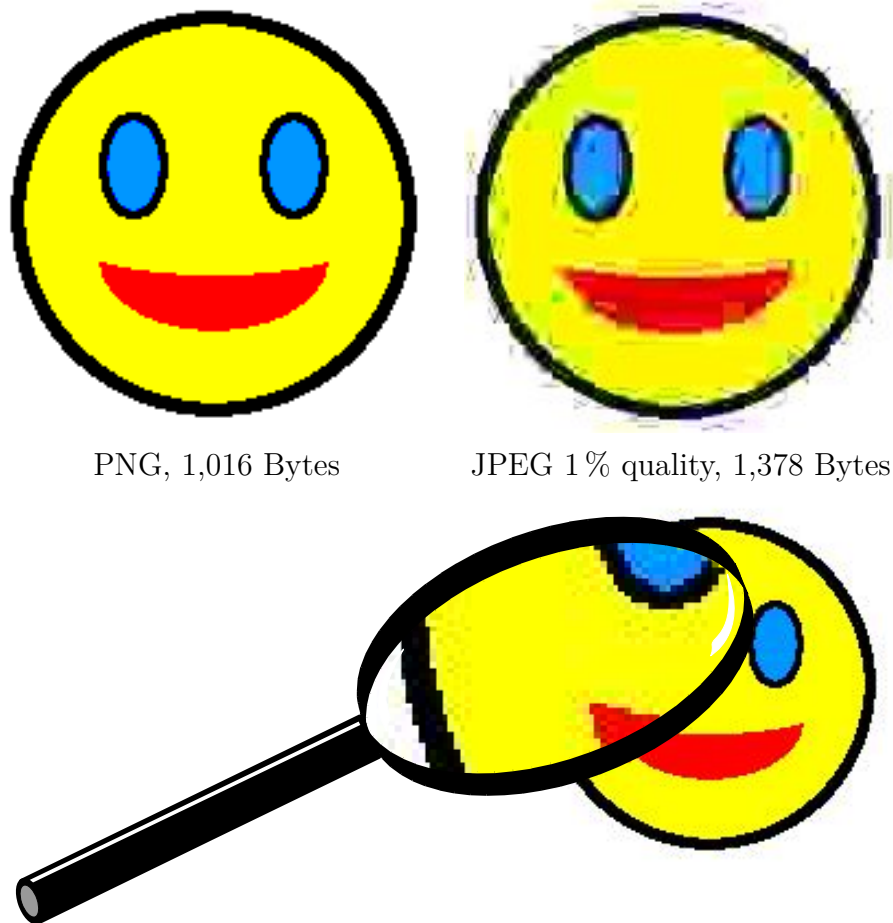

PNG, 1,016 Bytes

JPEG 1% quality, 1,378 Bytes

Figure 9.6: The detail of image with unproper compression.

provements. There are used more sophisticate mathematical methods. The DCT is not used, but *discrete wavelet transformation (DWT)*. Wavelet transformation is one of methods for frequency domain representation of signal and has some advantages over DCT. A functions with defined wave shape are used instead of sinuses and cosinuses.

Thanks to new transform method the compress ratio is better about 20 to 30%. The images with sharp edges and color gradients have lower distortion.

Users of new format appreciate the most a better compression ratio and higher image quality when using the lossy compression. DCT in JPEG format requires the division of the image into small 8×8 blocks, while JPEG2000 uses the whole image. The RGB color coding is used. And in addition the user has the choice to mark "area of interest". These areas are part of the image, where is required to set lower or higher compression ratio. For use in DSSTV is advantageous fault tolerance of the data stream. Only a small portion of the image displays poorly in the case of

faulty transmission, other sections carried well are not affected. For older JPEG, the image part following the fault data of stream used to be completely discarded.



Figure 9.7: File size depends on the compression ratio of JPEG 2000.

The new JPEG2000 has also progressive mode like an old JPEG. So the received image can be viewed during reception. You can see phases of reception in [fig. 9.8](#).

9.3.4.3 Lossy versus lossless image compression — conclusion

In JPEG section is described that lossy compression is not suitable for all types of images. Charts, diagrams and other images featuring sharp color gradients get significant loss, see [fig. 9.6](#). Despite the significant quality loss the file size is not considerable reduced. inTable[tab:comparison] contains a comparison of file size for various formats. As the input file was used “smiling face” from [fig. 9.6](#) stored at a resolution of 256×192 in 16 colors.

Even relatively dumb RLE algorithm for lossless compression, but maintaining a 100% quality beats JPEG. It is the user’s choice how to deal with the right choice of

format and select a suitable compromise between resolution, number of colors and image quality.

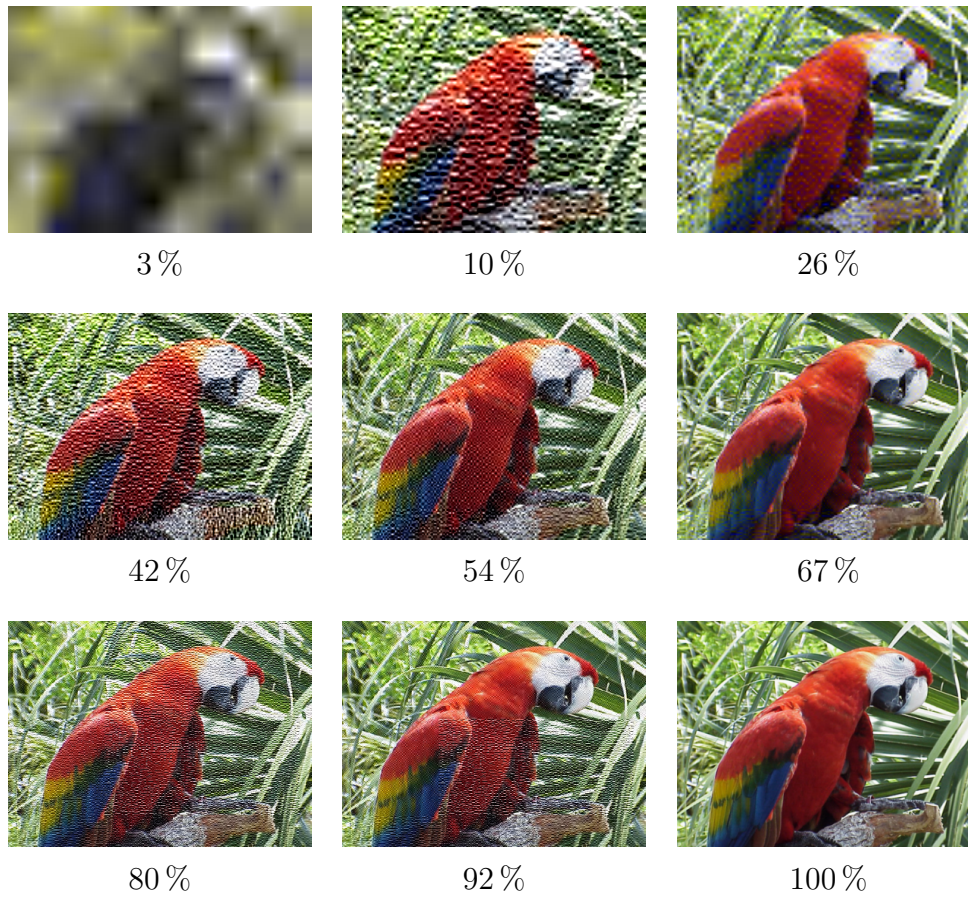

Figure 9.8: Progressive display of JPEG2000 image depends on amount of transferred data, original image has 400×298 resolution.

Format	Quality	File size
Windows Bitmap	100 %	24,654 B
JPEG	100 %	17,740 B
JPEG	75 %	7,300 B
JPEG	50 %	5,298 B
TIFF, PackBits compression	100 %	4,352 B
Windows Bitmap RLE	100 %	3,984 B
TIFF, komprese LZW	100 %	3,850 B
JPEG	25 %	3,766 B
GIF	100 %	1,569 B
JPEG	1 %	1,378 B
Portable Network Graphics	100 %	1,111 B

Table 9.4: Comparison of file sizes for different graphic formats.

10

DSSTV transmission systems

10.1 Redundant Data File Transfer

This communication mode uses *phase shift keying (PSK)* modulation. The simplest PSK modulation changes subcarrier between two phase states (*BPSK – biphas shift keying*) and these states corresponds to level of logical zero or one. This is used for example for teletype mode PSK31.

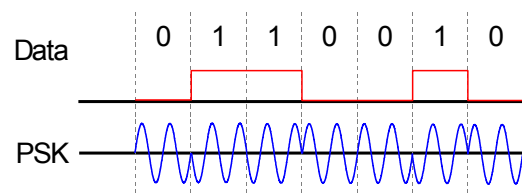

Figure 10.1: Two-phased digital PSK modulation.

RDFT uses similar principle but much more extended. The signal is composed from eight subcarriers from 590 Hz to 2200 Hz with 230Hz steps. Each subcarrier uses nine modulation states – eight informational states and one state with *no change* meaning. The data from inner encoder are used for phase assignment.

The first step in modulation process is to take a cosine of modulation angle plus 1400Hz subcarrier angle. In next steps the energy around 1400 Hz is isolated and translated onto right subcarrier. Then the subcarriers are compiled together and resulting spectrum of signal is in **fig. 10.3**.

The signal contains two levels of error-coding. The outer coding scheme use RS code $(306, x)$, where x is set by level of error control, see **tab. 10.1**. The symbol numbers, produced by the outer encoder, are the input to the inner encoder. The inner coding scheme uses $RS((8, 4))$, where is 50% redundancy. All 8 symbols are used for phase settings for each of 8 subcarriers, so the inner code-block is transferred paralely. The decoder of inner code on reception side is able to correct whole block if 6 of 8 symbols are transferred without error.

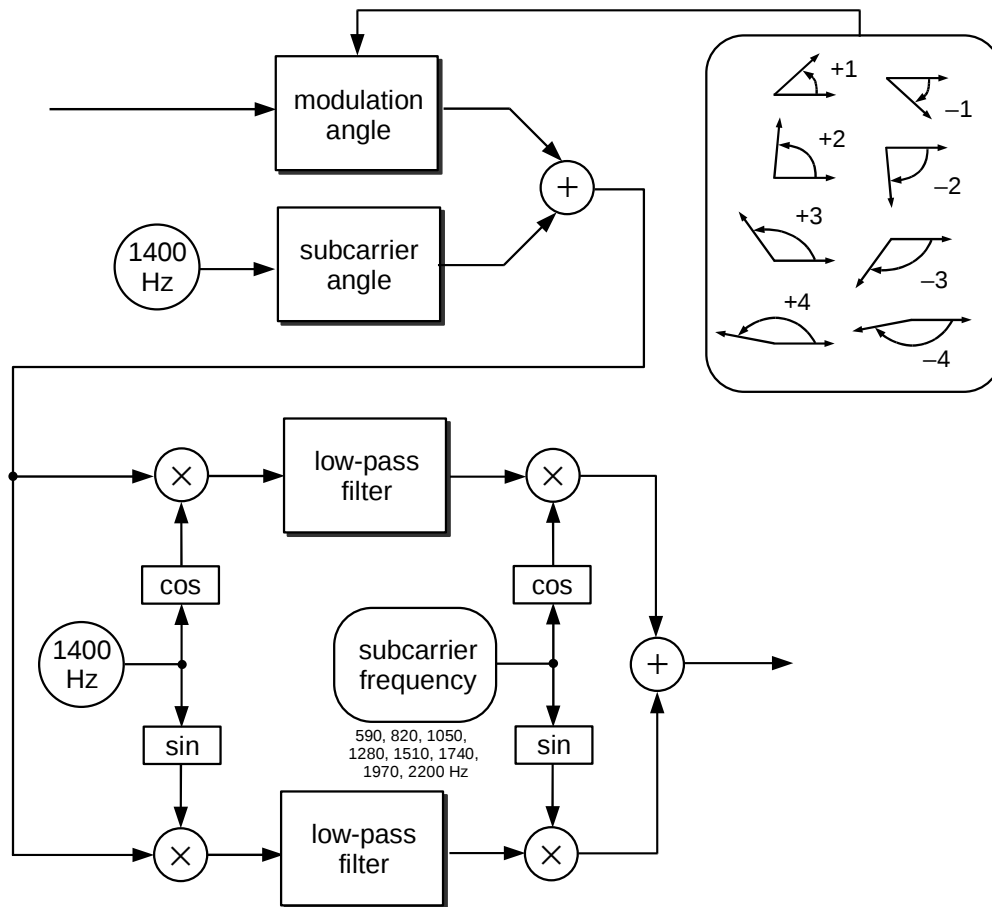

Figure 10.2: Block diagram of RDFT modulator for one subcarrier.

Operator can choose one of four modes, in all cases the modulation speed is same 122,5 Bd, but the level of error control differs.

Table 10.1 are parameters of RDFT modes. You can choose lower error control level when band conditions are good or higher level in case of bad conditions and big interference. The redundant data consume 70% of all transferred data for *Wyman 14*, so there is possible to apply an extensive error-correction. The *Wyman 13* is recommended for long-distance contacts and *Wyman 12* for intracontinental QSOs.

Transferred data block consists of three parts:

- ▷ The first is *LEADER*, it uses always same modulation scheme and error-coding. It contains RDFT mode identification and it is used for detection of two parameter. The first parameter is a tuning deviation in Hz, because most SSB transceivers have smallest tuning step 10 Hz it is not possible to tune accurately. The next parameter is clock rate difference, it is caused by inexact sample rates

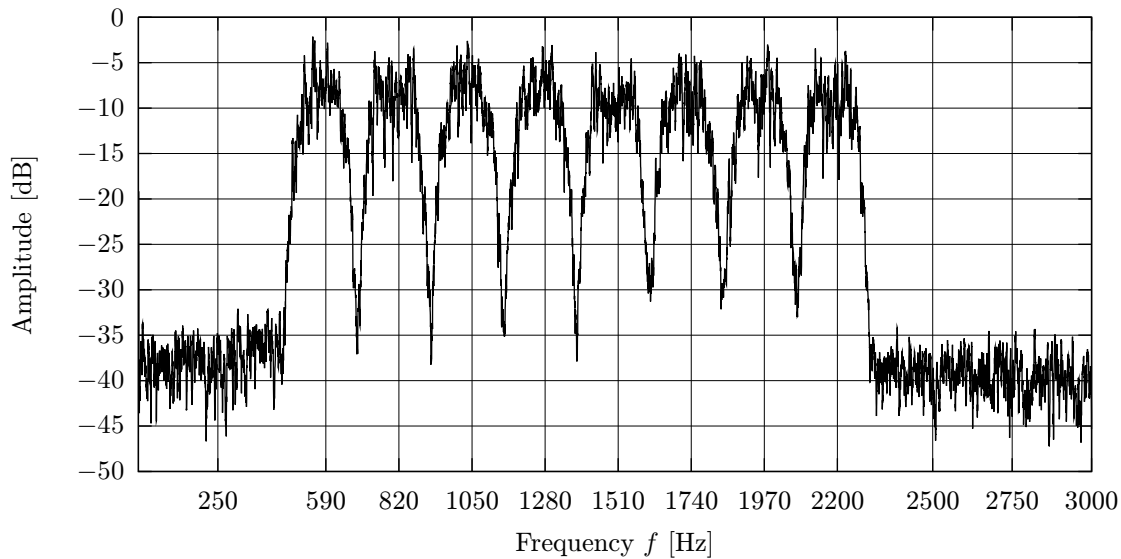

Figure 10.3: RDFT frequency spectrum

RDFT mode	Subcarrier number	RS code	Redundancy	Maximum errors	Bandwidth	Bit rate	Symbol rate
Wyman 11	8	(306, 274)	10 %	16	1840 Hz	866 bps	122,5 Bd
Wyman 12	8	(306, 242)	20 %	32	1840 Hz	765 bps	122,5 Bd
Wyman 13	8	(306, 178)	40 %	64	1840 Hz	563 bps	122,5 Bd
Wyman 14	8	(306, 92)	70 %	107	1840 Hz	291 bps	122,5 Bd

Table 10.1: RDFT communication modes.

of sound cards and there is also small difference on receiver and transmitter side. Both these parameters are dynamically found during transmission and they are used in demodulation process.

- ▷ The next part is *CODEBLOCK*, it is sequence of data frames of transferred file with redundancy symbols for error correction.
- ▷ The transfer ends with *TRAILER*, it contains mode identification like the first part.

The average bit rate of transfer is about 736 bps (92 bytes per second).

The input of demodulator are samples of RDFT signal, the output are some phase states of each subcarrier. The block circuit of demodulator is in [fig. 10.2](#). The *delay* block provides a delay of one symbol period. Subtracting the angle values separated in time by one symbol period is the “differential” portion of this “differential phase demodulator”. The *average* block averages 24 adjacent differences and divides by the unit phase step, to produce the final demodulator output. This averaging helps reduce the intersymbol interference produced by the low pass filters.

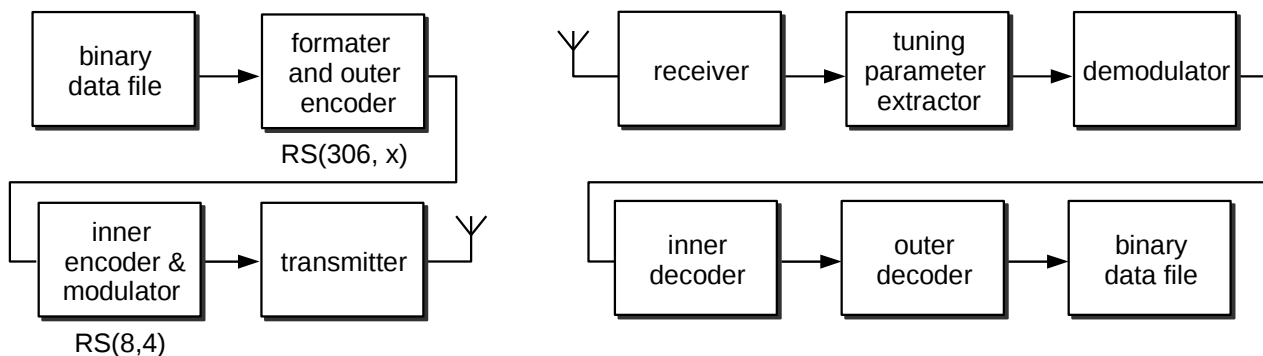

Figure 10.4: RDFT communication channel.

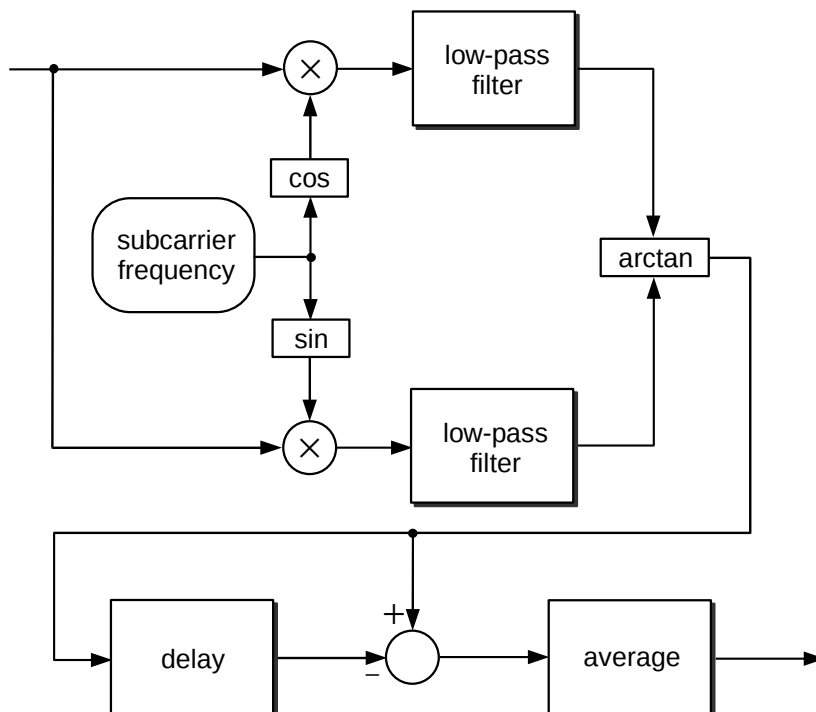

Figure 10.5: The RDFT demodulator block diagram.

10.1.1 RDFT operations

The audio level of sound card is the most important setting on TX side. It must be inside linear range, it is usually the middle half of its dynamic range. On RX side should be sound card level adjusted too. The input signal should not be overdriven, it causes unwanted nonlinearities.

The stations should be very precisely tuned to each other for making successful contact. The station before the data transfer should send tuning signal. This

signal consist of two tones 1180 and 1520 Hz. These frequencies are labeled on spectroscope, so you can fine tune and align the frequency peeks with the marks.

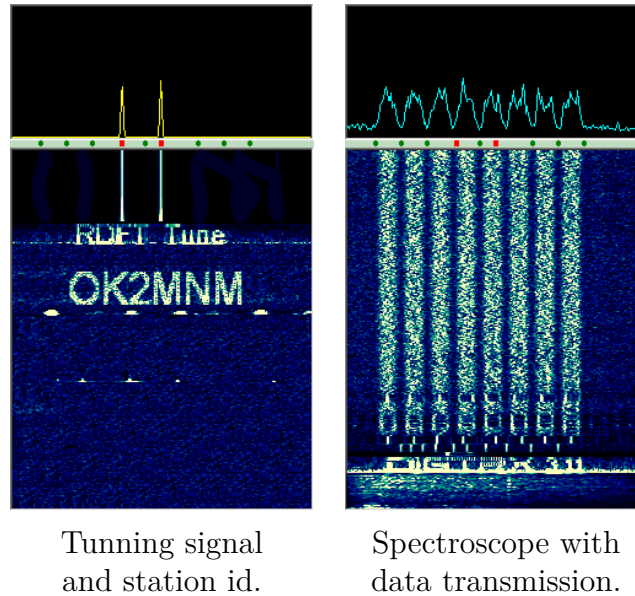

Figure 10.6: The tuning spectroscopce in DIGTRX.

Following operations must be done for transmission and reception of images:

1. Original data file is processes, in case of images the resolution and compression level are set. Then is generated WAV audio file, which contains a audio signal for radio transmission. The time spent to signal generation is derived from input file size and computer configuration. It can took form a second or two (2GHz and faster CPUs) up to several minutes on slower systems (400 MHz).
2. The audio file is played and transmitted. The reception station records sound and store it on a hard drive.
3. The software process recorded WAV file and reconstructs original file. This step is also computationally very demanding and the time needed for decoding depends not only on the volume of data and processor speed, but also on how much is necessary to use the error-correction algorithm. This step may take several minutes on a slow computer, on a 2GHz machine it takes 15 seconds.

Barry Sanderson, KB4VAK, developed programs for RDFT encoding. These program are command line driven and it is available as open source under GNU GPL license. So programmers can implement it to several computer platforms. So thanks to open source idea, there is few programs where is the RDFT mode available.

RDFE presentation in Dayton conference: <http://replay.web.archive.org/20080528090630/http://www.svs.net/wyman/examples/hdsstv/>

10.2 HamDRM system

Communication system *HamDRM* is derived from open standard Digital Radio Mondiale [12], which was created for digitalization of radio broadcast on medium-wave and short-wave bands. Normal DRM use bandwidth 4.5 kHz to 20 kHz for sound quality similar to FM broadcast on VHF. The hamradio version *HamDRM* was created by Francesco Lanza, HB9TLK. It is modified for usage in SSB channel with 2.5 kHz bandwidth. HamDRM can be used for image and data file transfer and also for voice communication, so it should be competitor for analog SSB in future.

The used modulation is *COFDM* (*Coded Orthogonal Frequency Division Multiplex*), which has maximal utilization of communication channel. The Reed-Solomon code is used for error correction.

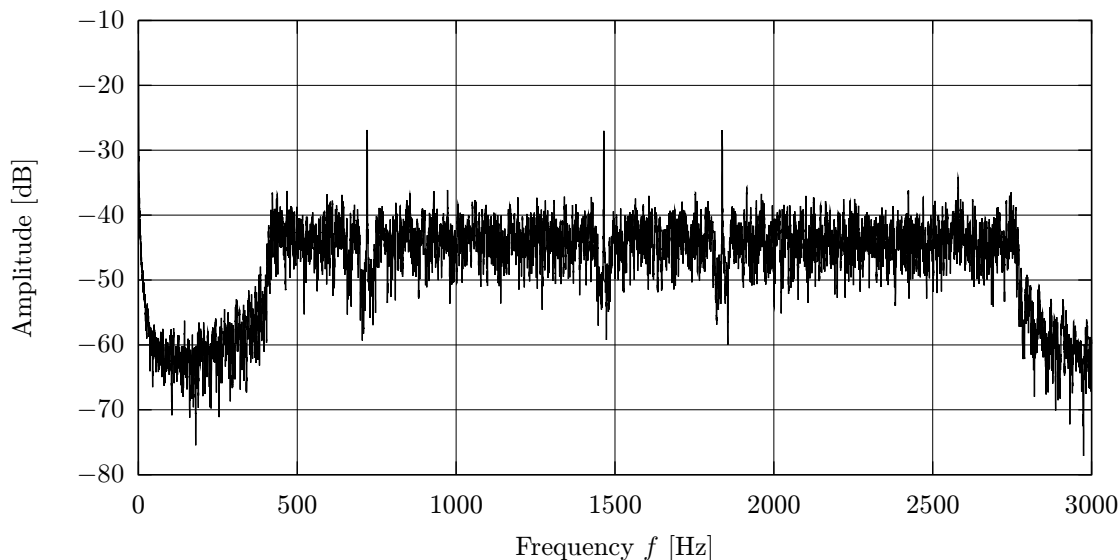

Figure 10.7: The frequency spectrum of HamDRM system.

The OFDM signal consists of a huge number of subcarriers in baseband. There are from 29 to 57 subcarriers in case of HamDRM. An each subcarrier is modulated independently with quadrature amplitude modulation (QAM) and together with error-correction code creates COFDM. This modulation is well resistant to phase distortion, attenuation, selective fading and pulse interference. The used modulation techniques are described later in [section 10.2.2](#).

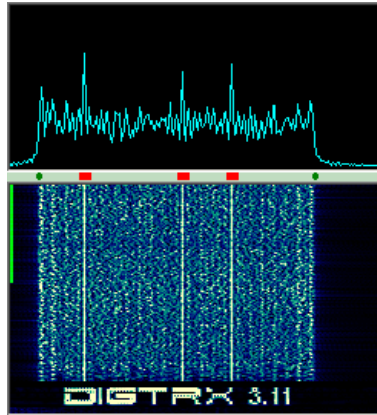

Figure 10.8: The tuning spectroscope in DIGTRX. Note three frequency peaks, that is used as guidelines for proper tuning.

Unlike RDFT, which needs 3 partial operations – coding, recording of broadcast and decoding, the HamDRM doesn't transmit data in whole block, but the file is divided into separate segments, so the image can be decoded and displayed during transmission.

HamDRM can be used in three basic modes. The *Mode A* allows the fastest transmission, but does not protect against the negative effects caused by selective fading. The *Mode B* is slower than the first mode, but is resistant against the negative impacts and it's much more robust. The last mode is *Mode E*, which is designed for communication through a channel with large delay and Doppler effect.

The QAM modulation is used with 4, 16 or 64 states. Modulation QAM-64 is the fastest but it needs a very good level of signal-noise ratio, at least 18 dB. Modulation QAM-4 is slower, but is more resistant to interference and requires a lower signal-noise ratio, about 5–6 dB. Minimum SNR for QAM-16 should be about 8–10 dB. The selection of modulation depends on an user and an actual conditions prevailing on the band. Other HamDRM features that can be set by user are following:

- ▷ *Interleaving* is used for change of symbol sequence, it is a way to arrange data in a non-contiguous way to increase performance. The long interleave has 2 seconds, it supports better error-correction but causes longer delay during decoding. The short interleave take 400 ms.
- ▷ *Bandwidth* can be changed to 2.3 kHz or 2.5 kHz. A narrower SSB filter can be used for lower bandwidth, but transfer speed is little lower.
- ▷ *Amount of instances* is value that gives number of file repetitions during transmission. If there is more than one instance then all segments will be repeated and

the error parts can be corrected automatically on reception side during second or third instance. The number of instances makes transmission time longer.

- ▷ *Leadin* is broadcast at beginning of transmission. This initialization is used to receiver synchronization, extra time allows better synchronization and automatic set up of reception settings.

Details of the mode and its parameters, along with the call sign is broadcast throughout the transmission with QAM-4 modulation, so it is possible to tune to signal during transmission, but the complete data will be received if at least one complete instance of the transferred file is received.

Mode	Bandwidth	Number of subcarriers	Level of MSC FEC	Transmission speed [bps]		
				QAM-4	QAM-16	QAM-64
A	2,3 kHz	53	normal	1480	2710	4170
			low	1900	3470	5340
	2,5 kHz	57	normal	1760	3220	4960
			low	2260	4130	6360
B	2,3 kHz	45	normal	1070	1950	3000
			low	1370	2500	3850
	2,5 kHz	51	normal	1270	2320	3570
			low	1630	2970	4580
E	2,3 kHz	29	normal	690	1270	1950
			low	890	1620	2500
	2,5 kHz	31	normal	820	1510	2320
			low	1060	1930	2970

Table 10.2: The parameters of HamDRM modes and their transmission speed.

Parameter selection of HamDRM modes affects the transmission performance, and hence the transmission speed, which depends on the settings, see [table 10.2](#). The two corresponding stations should not communicate with each other in the same mode. E.g. station X has a considerable local interference, so station Y sends in a more resistant mode, but Y hasn't this problem, so X can easily transmit in a faster but less resistant mode.

If the transfer of some segments fails completely, it is not lost at all, because your QSO partner can send *bad segment report (BSR)* and you can resend bad segments again. It's important to send BSR in same mode. The repeated segments can be received third station too and if have not all segments received it can complete

whole data. When band conditions are really bad and part of resend fails again, it is possible to generate the new BSR, so the amount of transferred data will be lower in next resent.

The DRM transfer consist of three channels – MSC, SDC and FAC. Each channel is dedicated for transmission of certain data or service information and also for each is used different coding and modulation scheme.

MSC – *Main Service Channel* contains data for all services of DRM multiplex. The multiplex can contain one to four services and each can transfer data or service information.

FAC – *Fast Access Channel*, is support channel. It uses QAM-4 and broadcast callsign, DRM mode identification (band spectrum occupancy, interleaving, mode of MSC and SDC modulation,...). FAC channel with service information transfer packet with 40 bit size:

- ▷ 2 bit FRAME-ID, identifies a frame in a superframe, value 0, 1, 2
- ▷ 1 bit Spectrum Occupancy (2.3 / 2.5 kHz)
- ▷ 1 bit Interleaver Depth (400 ms / 2 s)
- ▷ 1 bit MSC Mode (QAM-16 / QAM-64)
- ▷ 1 bit Protection Level (amount of FEC used)
- ▷ 1 bit Audio/Data
- ▷ if *audio* is used, then follows:
 - ▷ 2 bit, audio codec: LPC, unused, SPEEX;
 - ▷ 1 bit, text flag;
- ▷ if *data* is used, then follows:
 - ▷ 2 bity, Packet ID;
 - ▷ 1 bit, extended MSC mode (QAM-4);
- ▷ 21 bits, Label, consisting of 3×7 bit ASCII characters (9 characters in superframe)
- ▷ 1 bit, dummy
- ▷ 8 bitů, CRC, used polynomial $G(x) = x^8 + x^4 + x^3 + x^2 + 1$.

SDC – *Service Description Channel* contains information of MSC decoding scheme and broadcast service attributes during multiplexing.

10.2.1 Comparison of HamDRM and RDFT

There are several software products for RDFT and HamDRM, but preference of users inclines to HamDRM. Main reason for HamDRM popularity over RDFT are:

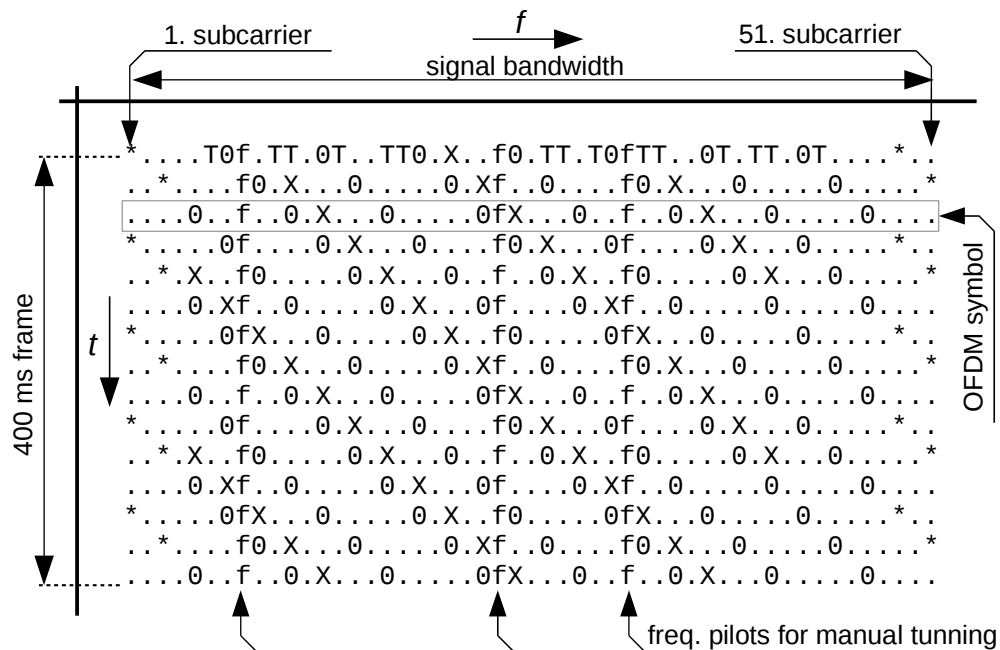

Figure 10.9: Example of frame for *Mode B*, spectrum occupancy 2.5 kHz. Legend: : – DC-carrier, . – MCS cells, X – FAC cells, T – time pilots, f – frequency pilots, 0 – scattered pilots, * – boosted scattered pilots.

- ▷ it is possible to decode and display image during transmission;
- ▷ transfer speed is better up to 3×;
- ▷ HamDRM continuously broadcasts station identification, so receiving operator can start reception and direct yagi;
- ▷ thanks to several instances, it isn't necessary to record the transmission from beginning to end;
- ▷ when reception failed, only bad segments can be repeated, not whole transmission;
- ▷ main disadvantage of HamDRM is, that the powerful PC configuration and OS better than Windows 2000 is a must.

10.2.2 Quadrature amplitude modulation — QAM

Quadrature amplitude modulation (QAM) uses amplitude and phase modulation together. HamDRM for each subcarrier (OFDM cells) can use several modulation schemes, which differ in number of modulation states – QAM-4, QAM-16 and QAM-64.

The number of modulation states QAM- m is divided into \sqrt{m} states for phase keying and \sqrt{m} amplitude levels. Thanks to multistate modulation it is not required

so huge bandwidth, on the other hand, a growing number of states of modulation makes the signal less resistant to interference.

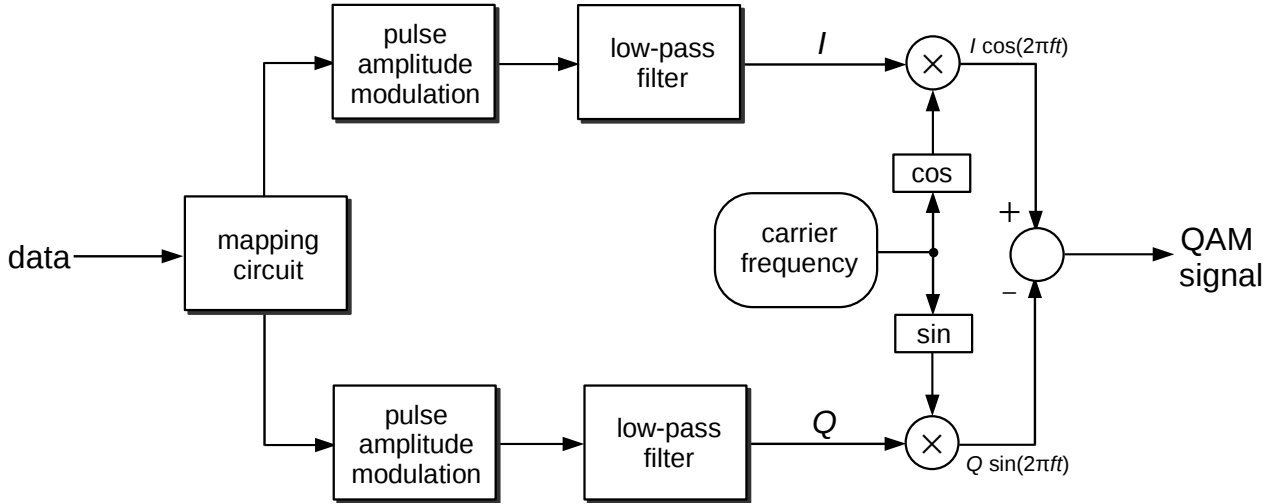

Figure 10.10: The QAM modulator.

An modulation state is created from combination of amplitude and phase, which can define a bit word of length l . For QAM-4 is the word length $l = \log_2 m = \log_2 4 = 2$, for QAM-16 is $l = 4$ and for QAM-64 it is 6. The modulation changes between these states:

$$A_k = 2k - 1 - \sqrt{m} \quad \text{pro } k = 1, 2, \dots, \sqrt{m}.$$

E.g. for QAM-16 levels are $-3, -1, 1, 3$.

The signal, which can be presented like

$$S_k(t) = A_k \cos(2\pi ft + \phi_k)$$

has 16 combinations of amplitudes A_k and phases ϕ_k .

The block diagram of QAM modulator see in **fig. 10.10**. Now, we describe how QAM-16 modulates data sequence $N = \{0, 13, 5, 2, 10, 7, 6, 5, 1, 15\}$. The result is **fig. 10.12**. The information words with 4bit length are divided on two parts in mapping circuit and first 2bit combination is coded in *pulse amplitude modulation (PAM)* into one of four levels. The way how to code input bit quaternion $\{i_0, i_1, q_0, q_1\}$ is defined by *constellation diagram*, **fig. 10.11**. E.g. for input 0 it is $i_0 i_1 = 00, q_0 q_1 = 00$ and this corresponds to $I = 3, Q = 3$, the next value 13, in binary 1101 corresponds $i_0 i_1 = 11$ output $I = -3$ and for $q_0 q_1 = 01$ output $Q = -1$, etc.

The results of PAM are pulses with given amplitudes and they are filtered with low-pass filter for the bandwidth reduction and for in phase path I and similarly for quadrature path Q . The I and Q are input signals for modulators with carrier

frequency f . This way there is a phase of 90° between them. Output signal is made by joining of both paths together:

$$S_k(t) = I_k \cos(2\pi ft) - Q_k \sin(2\pi ft).$$

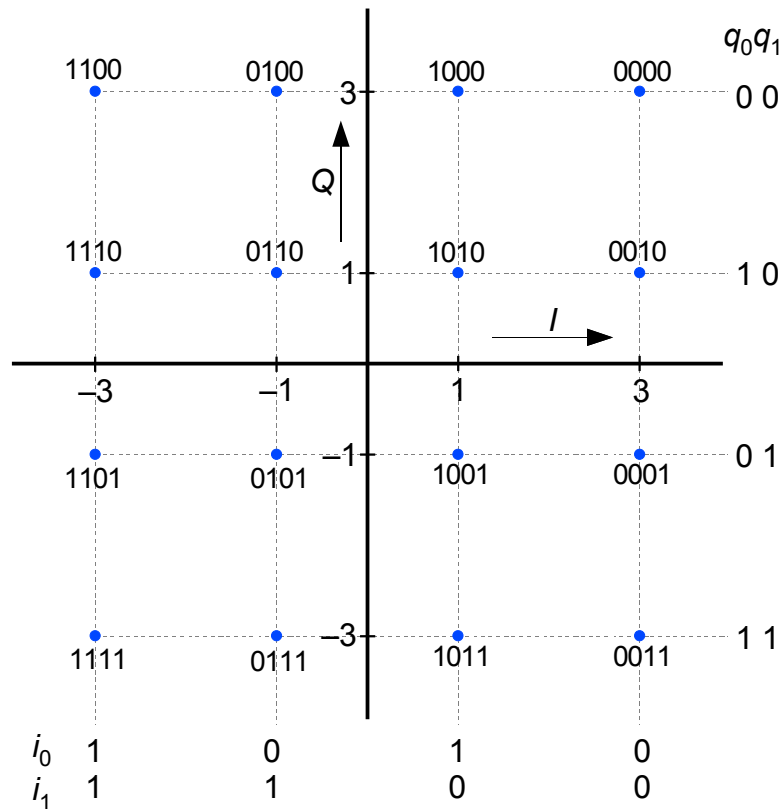

Figure 10.11: The constellation diagram for QAM-16 with bit order $\{i_0, i_1, q_0, q_1\}$ used in DRM.

10.2.3 Orthogonal frequency-division multiplexing — OFDM

OFDM is a representative of the modulation scheme with multiple carriers *MCM* (*Multicarrier Modulation*). Thanks to its properties the OFDM found application in many modern technologies, i.e. ADSL, WiFi (IEEE 802.11a/g) networks, WiMAX and standards for digital broadcast and terrestrial digital television DVB-T, etc.

OFDM has very good spectral performance and it is resistant to pulse interference, because transferred information is dispersed in wide frequency spectrum, so interference disturb only few nearby symbols. It's also resistant to inter-symbol interference, fade outs caused by multipath spreading and has low sensitivity to errors in time synchronization.

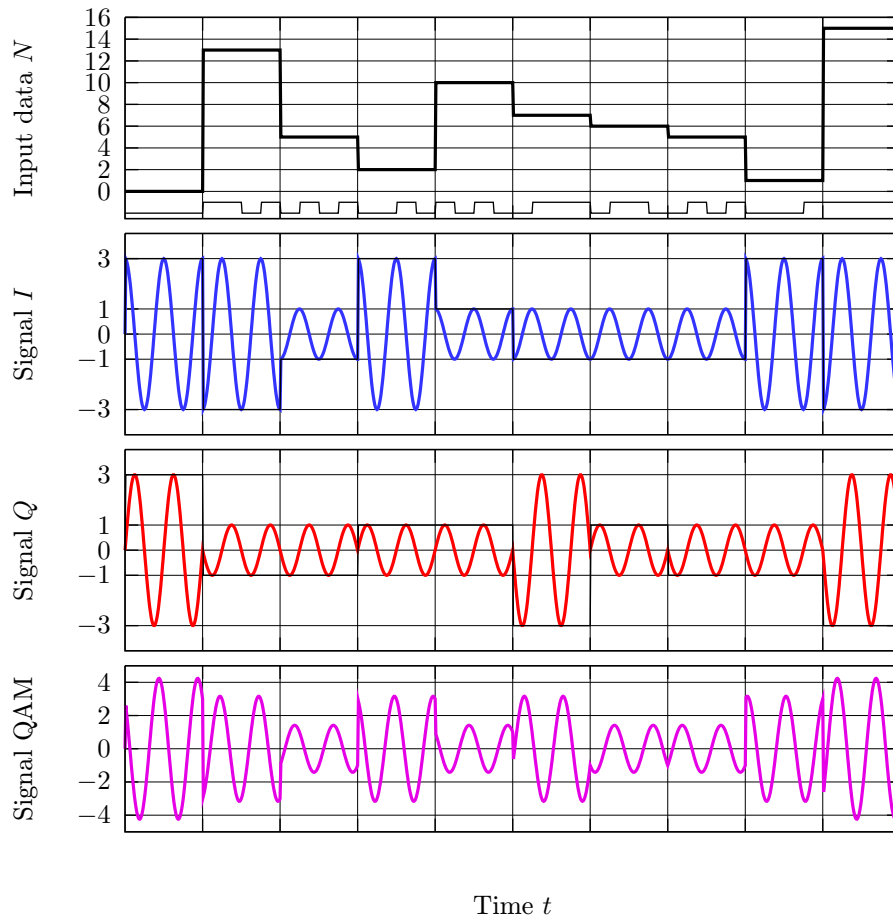

Figure 10.12: The example of QAM-16 modulation for input data sequence.

The OFDM generates a huge number of subcarrier waves and in case of HamDRM there are for best performance *only* 57 subcarriers. Many other applications like digital video broadcast or wideband data communication uses hundreds or thousands of subcarriers! These subcarriers have very small distances, even those, that the overlap the range of others. An example of OFDM spectrum is in **fig. 10.13**, as spectrum of each subcarrier is considered the spectrum of rectangular signal, which is expressed by $\sin(x)/x$ function.

The subcarriers has exact distances, so maximal level of spectrum of each subcarrier is null in maximal levels of other subcarriers, so they are mutually *orthogonal*.

10.2.3.1 OFDM transfer

The modulator block diagram is in **fig. 10.14**. Input data stream comes to serial-parallel converter and it is cyclically distributed to a larger number of parallel

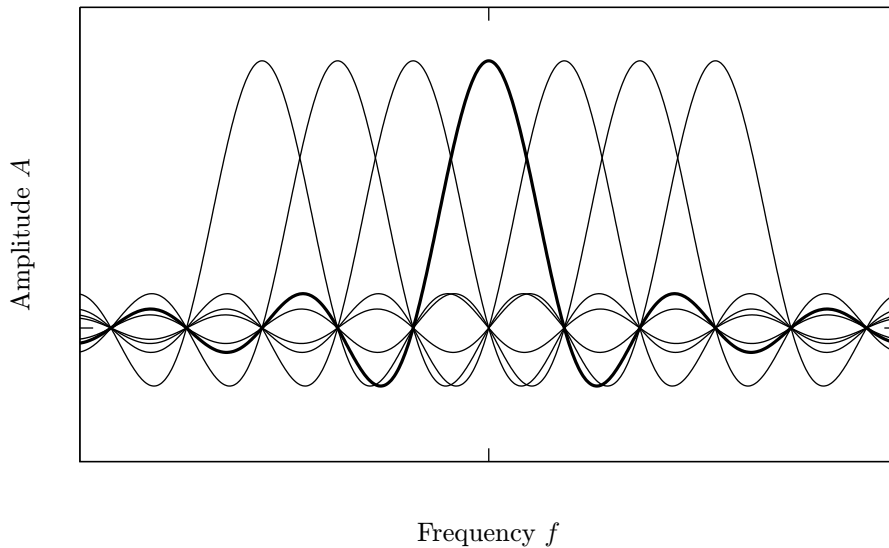

Figure 10.13: The frequency spectrum of orthogonal carrier waves.

components. The parallel component transmitted simultaneously creates a complete OFDM symbol. Components are also modulated to the orthogonal system of N subcarriers, the frequencies are distributed to ensure their orthogonality. Subcarrier waves in our case use modulation QAM-4, QAM-16 or QAM-64, but for some other applications there are used multiphase BPSK or QPSK.

A signal processor provides modulation of huge number of subcarriers, in our case it is software, which implements algorithms for inverse discrete Fourier transform (DFT^{-1}). Because DFT algorithm has big computing complexity there is used its faster variant *FFT* (*Fast Fourier Transform*). The inverse FFT (FFT^{-1}) transform input data from frequency domain to time domain. The process on a receiver side vice-versa use direct FFT to obtain individual subcarriers.

Two data stream are outputs of FFT^{-1} , which are converted with digital/analog converters on two analog signals. Then these signals are modulated to main carrier and there is a phase of 90° between them. The *Re* signal presents amplitude component and *Im* signal phase component. Both joined together creates transmitted OFDM signal.

Everything on reception side goes in opposite way. The received signal is amplified and converted to lower frequency. Then signals *Re* and *Im* go through low-pass filters to analog/digital converters and data from them is processed by DSP with direct FFT and divided into individual subcarriers. The output data are compiled in parallel-serial converter.

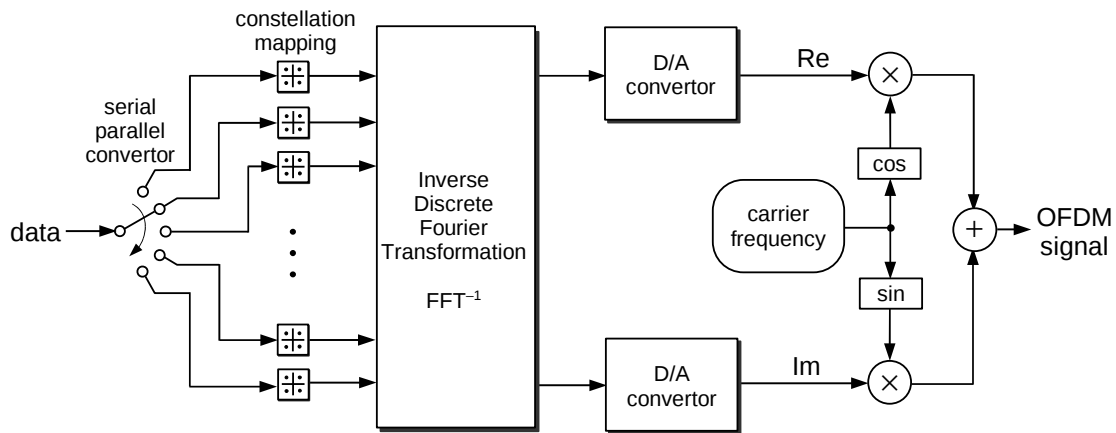

Figure 10.14: The OFDM modulator use fast Fourier transform (FFT^{-1}) for making a huge number of modulated subcarriers.

10.3 DSSTV software selection

There is several programs available supporting HamDRM and RDFT.

Software	RDFT	HamDRM	Web page
DIGTRX 3.11	★	★	http://www.qslnet.de/member/py4zbbz/hdsstv/HamDRM.htm
DigiACE V1.9	★		http://homepage.ntlworld.com/mhemmerson/
DigPAL		★	http://www.home.bellsouth.net/p/PWP-hampal
EasyPAL		★	http://vk4aes.com/
HamPAL		★	http://www.home.bellsouth.net/p/PWP-hampal
RDFT	★		http://www.svs.net/wyman/examples/hdsstv/
RXAMADRM (Linux)		★	http://pa0mbo.nl/ties/public_html/hamradio/rxamadrn/index.html
SSTV-PAL Multimode	★		http://f6baz.free.fr/FTP/SSTVPalPlus/
WinDRM		★	http://n1su.com/windrm/

10.4 Making QSO

Digital SSTV is not spread too far. There are few station found sporadically on the 14MHz band. But there is also working party of German stations on the 3.7MHz

band around the frequency 3.733 kHz almost daily in the evening. Stations use only HamDRM system. Listening to their signals is a good opportunity to try DSSTV reception and get some practice with it, also try to make contact. After that, you already know how there is used special modulation schematic and error-correcting coding it is important to see if it at all works and how. Will be there SSTV digitalization boom?

Some opponents of digital video broadcast claim, that in conditions where we can receive noisy, but still usable analog TV signal, the digital TV cannot be received at all. And same argument can say opponents of digital-SSTV. When there are good conditions, it is possible only to tune on channel, images are received automatically and operator should not do anything. When interference gets stronger and signal weaker there can help more data instances or bad segment report and additional repetition of bad segments. But when we only guess HamDRM signal drowned in high noisy level the reception is impossible.

The DSSTV traffic can be found on band near the centre of SSTV activity. Also hamspirit rules should be observed and we should be considerate to another traffic on the band. Sometimes it takes a little tact to explain to uninformed station, that the strange rattling sound is the digital signal from your QSO partner.

A CQ call can be done by sending picture on free frequency. HamDRM during transmission broadcast station id, so is you don't receive complete data you can see what station is transmitting. After the end of transmission you can call the station by voice.

For reception confirmation or short message transfer there is used waterfall messages – messages displayed in tuning indicator. Principle of these messages is described in next [section 10.5](#) and example of some message see in [fig. 10.15](#).



Figure 10.15: The confirmation of successful reception displayed in tuning indicator

The reports are same as for the phone operation in the RS (readability and strength) code. The V (View) value representing image quality of digital transmission is losing

its importance. Readability is measured on a scale of 1 to 5, so level 5 stands for a perfect error-free transfer, level 4 is still acceptable, with occasional failure segments and potentially it's needed to increase the number of instances. Report the worst level 1 if can not receive any digital data.

Contrary to popular SSTV operations when stations restrict only to the exchange of images, the phone mode is much more used in case of DSSTV.

The choice of images is not limited to the usual 320×240 resolution, but there can be used any resolution. The limiting factor is only time of transmission, e.g. in the DIGTRX software the broadcast time is already known, so you can play around with the compression level, resolution, or number of colors and achieve a reasonable compromise.

Also, the transmitted data file format can be any. Listen on the band and you will make sure that JPEG2000 is often used, but also animated GIFs, or text files with ASCII art.

10.5 Waterfall images

For digital SSTV and RDFT or HamDRM system is used tuning indicator, which displays spectrum of SSB channel. The image showed by indicator is created using discrete Fourier transformation. The indicator displays new samples on top and the old samples disappear at the bottom and the whole spectrogram is moving down so the indicator was nicknamed *waterfall*.

In the **fig. 10.6** and **fig. 10.8** you can see station and software identification and also messages about reception confirmation, request for repeat or more complex pictures also.

The principle of “waterfall images” is based on Fourier transformation and the fact, that the signal can be compiled from a huge number of harmonic waves. If the proper harmonic are compiled, so the resulting carrier wave has frequency spectrum, that will look like desired image.

The utility `PicFall.exe` can be used for generating sound file from picture. You can find it on website of DIGTRX author. The input file is a bitmap in BMP format and output is WAV audio file.

Generate waterfall image by using `PicFall.exe`:

<http://www.qsl.net/py4zbx/tutsstv14.htm>

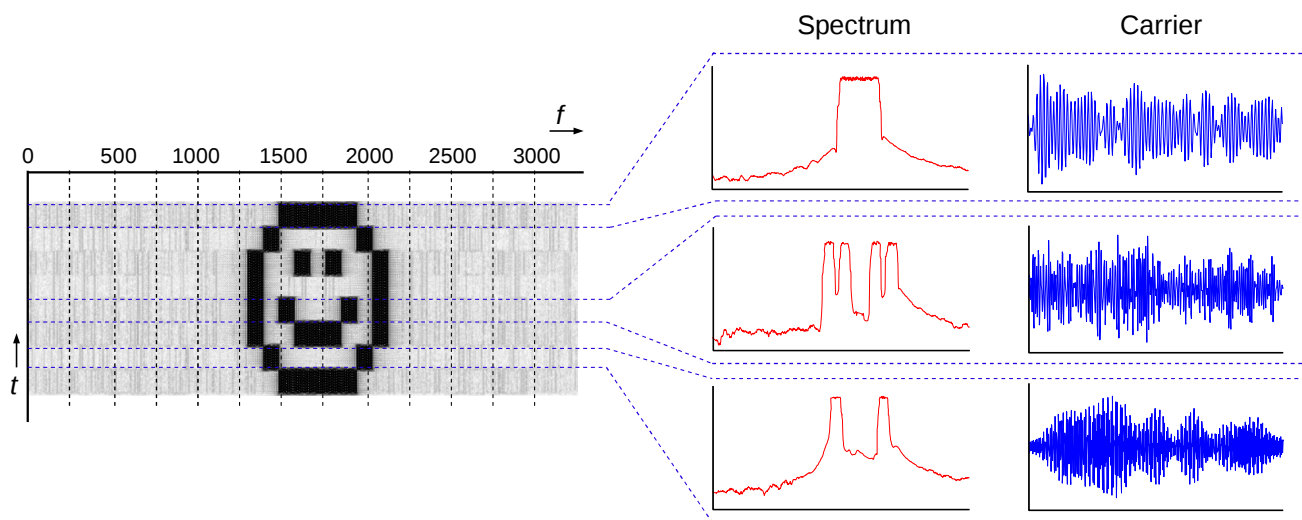

Figure 10.16: The principle of waterfall image display.

11

Facsimile — Radiofax

Facsimile (from latin *facere* – make and *simile* – similar) is one of the oldest communication modes and it is used for an image transmission. The facsimile is mainly used by professional services for wireless distribution of meteorological maps and informations, hence the name *Weather Facsimile (WEFAX)* follows from it. The *radiofax* can be used by radio amateurs too.

11.1 The history of image transmission

Already in 1843 a Scottish clockmaker Alexander Bain suggested that some images can be broadcast via electric lines, when it is electrically scanned by rows and point by point. That's the basic idea of image transmission.

Bain's example was soon followed by other entrepreneurs. In 1847 an Englishman Frederick Collier Bakewell reeled an image in the transmitter and sheet of paper to cylinder in the receiver, which was turned by the clock machine. The picture were printed with fat on a tinfoil sheet.

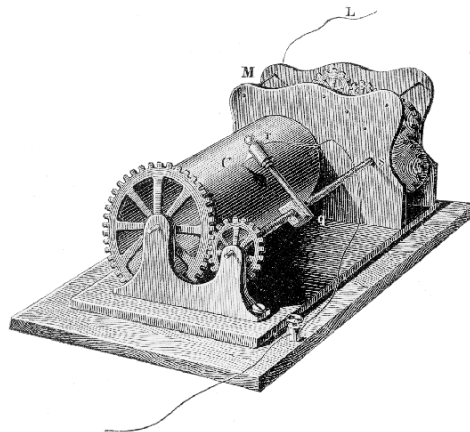

Figure 11.1: Bakewell's image telegraph.

A honor for the first fax service, however belongs to Giovanni Caselli, Italian catholic priest and physicist. In 1856 he built device named *panthèlègraph*. With pantèlègraph could be sent images or texts.

Caselli received enthusiastic support from the French emperor Napoleon III. The emperor personally visited his workshop in 1860 and enabled him an access to telegraphy lines. The first commercial fax service started in 1865 in Paris and it was connecting some major cities of France. Indeed the transmission was very slow and the fees were high so there was only few clients. The service wasn't profitable and had to be stopped.

In 1901 a German scientist Dr. Arthur Korn invented the principle of the photoelectric reading and began to transfer some positive photographic slides on a transparent substrate. These slides were illuminated point by point and row by row and light passed through transparent slide influence the selenium cell. The cell changes its resistance depending on the light intensity and transform image pixel shade to electric current. The receiver contained "light relay", a device with early gas-discharge lamp. The intensity of light exposed present point on photographic paper and it varied according to current flowed from receiver.

Dr. Korn designed the first phototelegraph device in 1902 and already in March 1904 he managed to reproduce photo transferred from Munich to Nuremberg. The transfer of postcard size photo took 24 minutes. In 1907 major cities Berlin, Munich, Paris and London were linked and his devices were bought by newspaper agencies and the first phototelegraphic service was founded.

The transfer was simplified by using of an electric photocell. Thanks to the photocell the transfer speed increased and the preparation of transparent slides wasn't necessary. The photocell is so sensitive that it is influenced by reflected light and some photos could be scanned directly. The photocell was used for the first time by American captain Richard H. Ranger for test transmission between Cleveland and New York. In November 30th, 1924 was wirelessly transferred photo of the British royal couple from London to New York. The first phototelegraphic service between America and Europe was established in May 1st, 1926.

11.2 The fax mode

The modern facsimile (fax) is used for transmitting images in the high resolution (usually 1810 dots per line) with image size up to several thousand lines. An relatively long time of transmission is used due to small bandwidth. In dependency on image size and transmission speed it takes from 3 to 20 minutes.

11.2.1 Image transmission

A typical mechanical transmitter consists of a cylinder rotated by a crystal-controlled synchronous motor. Broadcast material is attached to the cylinder, which rotates at a constant speed. A small ray of light is focused on the broadcast medium (map, text, photos, etc.). The light reflected from the medium is processed by a photoelectric sensor. The sensor bears the light source, photocell, and moves along the cylinder at a constant speed. The sensor moves from one end to the other and captures the image line by line. Voltage differences from the photo sensor are amplified and used to modulate the signal carrier.

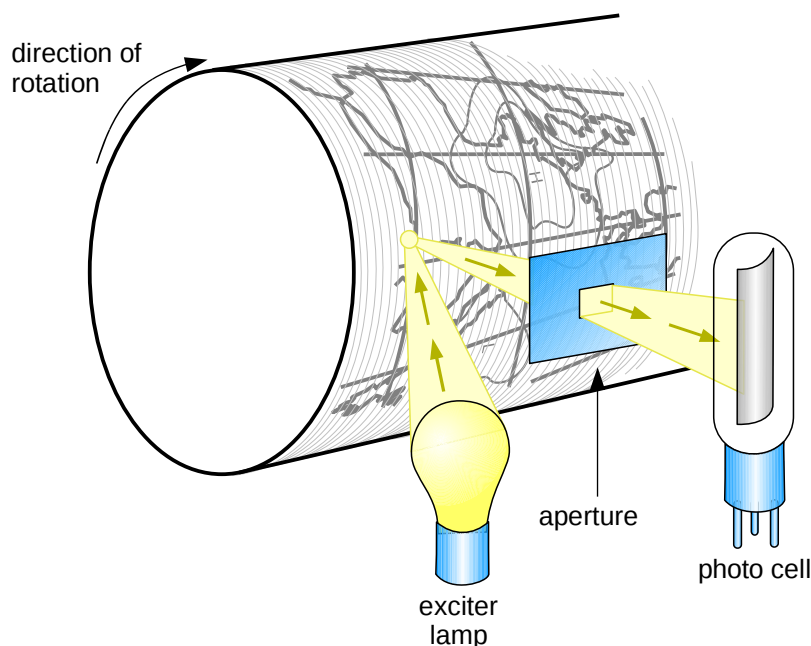

Figure 11.2: The principle of an electromechanical image capture.

The fax transmission on shortwaves has only few similarities with the fax machines you know from home and offices. The fax transmission is based on CCITT recommendations Facsimile CCITT Group 1 (T.2) of 1968, the short wave recommendation is described **chapter 11.6**. The CCITT recommends the frequency 1500 Hz for white and 2300 Hz for black. In North America it is 1500 Hz for white and 2300 Hz or 2400 Hz for black. The transmission speed is 180 lpm. The fax machines of this type could be adjusted for amateur operation. The later recommendations T.3, T.4 or T.30 can not be used on HF and there are used in telephone lines.

The frequency modulation *F3C* is used for shortwave transmission (*F* – frequency modulation, 3 – single channel containing analog information, *C* – facsimile). The

transmitter modulates the frequency of carrier in the range ± 400 Hz on shortwaves and ± 150 Hz on long waves. This range is called *signal deviation*.

The fax signal can be created by direct modulation of broadcast frequency or by frequency modulation of subcarrier 1900 Hz. Then the transmitter changes frequency between black and white colour. Black color corresponds to 1500 Hz and white 2300 Hz.

The amplitude modulation (AM) used for image transmission on VHF and microwave meteo satellite downlinks. There is used positive AM and level of modulation determines the brightness. For black colour it is 4% level and for white it is 90% to 100%. The negative modulation inverts levels, the minimal value is for white and the maximal value for black.

Most commercial stations use *APT – Automatic Picture Transmission* for a fully automated reception without requiring the presence of an receiver operator. The image transmission begins with *start tone*, when transmitter modulates the carrier with some frequency, mostly 300 Hz (changing the maximal levels of modulation $300\times$ in a second). This signal is recognized by the receiving device and it switches from stand-by mode to working mode and waits for *phasing signal*.

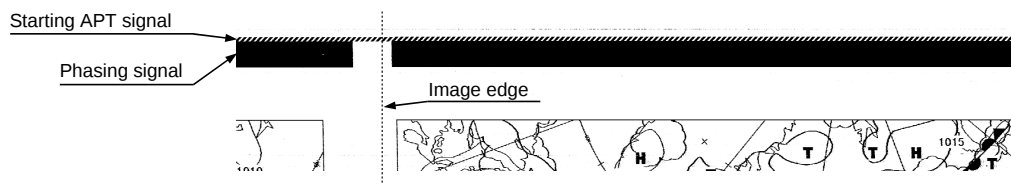

Figure 11.3: The start of facsimile transmission.

The phasing signal is used for synchronization and it is broadcast few second before an image. Normally consist of rows of 95% black and 5% white. It generates a vertical white line, which identifies the edge of the transmitted image.

After the end of image transmission another APT signal is sent, it has modulation 450 Hz and switches the receiving device back to stand-by mode.

11.2.2 The reception

Shortwave facsimile reception can be realized by using upper single sideband (USB) receiver. For this reason, you'll have to tune on the frequency, which is about 1900 Hz below the station frequency. So if the station uses frequency 3855.0 kHz, you must tune in USB on 3853.1 kHz (i.e. 1900 Hz below). All facsimile reception software is equipped by spectroscopy, the same as for SSTV, so precise tuning should not be a problem. You can control tuning by the fact that the largest portion in the fax image is mostly white.



Figure 11.4: Modern receiver Sony CRF-V21 for WEFAX and RTTY reception equipped with printer.

There are still used analog WEFAX receivers with electromechanical printers, but in our case we can use only PC with sound card and proper software.

The most important parameters of the transmission are the speed and *index of cooperation* – *IOC*. The IOC relates with a horizontal scan rate and can be converted to number of pixels by simple formula:

$$\text{line} = \pi \times \text{IOC pixels}$$

The most frequently used IOC is 576 (1810 pixels), then 288 (900 pixels).

The speed of transmission is given by rotation of cylinder (round per minute, rpm) and it is equivalent to number of lines per minute, lpm. Professional stations use most often 120 lpm, in eastern European countries and in post-soviet states it is 90 lpm, news agencies use 60 lpm and meteo satellites 240 lpm.

The most common fax images (synoptic maps) are transmitted only in black and white, but some images like retransmission of weather satellite images are in gray scale.

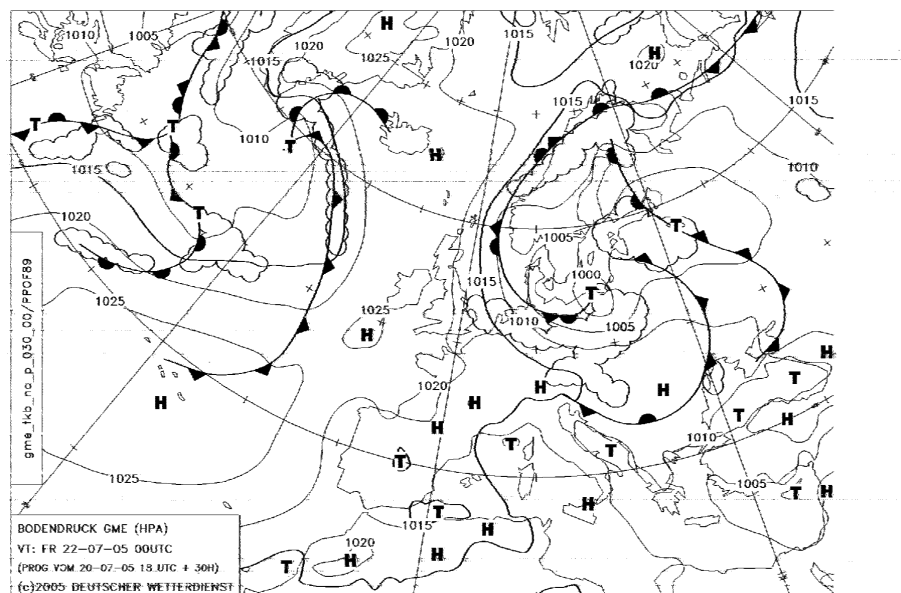

Figure 11.5: Typical synoptic map transmitted on HF by facsimile, here from station DDH3, line speed 120 lpm and IOC 576.

Name	IOC	lpm	APT start	d	APT stop	d	Note
Wefax 288	288	120 / 90 / 60	675 Hz	3 s	450 Hz	3 s	
Wefax 576	576	120 / 90 / 60	300 Hz	3 s	450 Hz	3 s	
Ham Color	204	360	200 Hz	5 s	450 Hz	5 s	color
Ham 288b	240	240 / 120	675 Hz	5 s	450 Hz	5 s	
Color 240	288	240	200 Hz	3 s	450 Hz	5 s	color
FAX 480	204	480	500 Hz	3 s	450 Hz	3 s	
Photopress	352	60	?	?	450 Hz	?	

d – minimal duration of APT signal

Table 11.1: Facsimile transmission modes.

11.2.2.1 Facsimile transmission modes

11.3 Professional stations

There are dozens of stations operating on high frequency bands. It depends on

your location, some of them are well-catchable all day, others only when conditions improve. Broadcast images are in most cases a variety of meteorological maps, synoptic charts, graphs of pressure and altitude, direction of wind, weather forecasts, cyclone or typhoon warnings, retransmissions of satellite imagery and broadcast of news agencies.

Even today when Internet is almost everywhere the fax broadcast has still its foundation. The main customers are naval ships, military, remote airports and islands, where the shortwave transmission is only way how to get actual information. They are often very important, because station distributes also weather warning of upcoming storm and hurricanes.

Each station has given its daily broadcast schedule, for example see 11.6. You can find here what images will be transmitted in a time of day.

FLEET WEATHER AND OCEANOGRAPHIC CENTRE, NORTHWOOD, ENGLAND	
AMENDED B14A RADIOFAX SCHEDULE WITH EFFECT FROM 190001Z JAN 05	
TIME-PRODUCT	TIME-PRODUCT
ALL TIMES IN ZULU	
0000 18Z SFC ANALYSIS	1200 06Z SFC ANALYSIS
0012 18Z SFC PROGNOSIS T+24	1212 06Z SFC PROGNOSIS T+24
0024 18Z 850MB WBPT/PPTN T+24	1224 06Z 850MB WBPT/PPTN T+24
0036 18Z OAT AND TD CONTOUR T+24	1236 06Z OAT AND TD CONTOUR T+24
0048 12Z SHIP ICE ACCRETION	1248 00Z SHIP ICE ACCRETION
0100 MAIN SCHEDULE	1300 MAIN SCHEDULE
0124 QSL REPORT	1324 QSL REPORT
0136 OCEAN FRONTS	1336 OCEAN FRONTS
0148 18Z 300MB GPH	1348 06Z 300MB GPH
0212 SYMBOLOLOGY	1400 00Z SEA SURFACE TEMP T+12
0236 00Z SFC ANALYSIS	1436 12Z SFC ANALYSIS
0300 00Z SFC ANALYSIS	1500 12Z SFC ANALYSIS
0348 04Z GALE WARNING SUMMARY	1548 16Z GALE WARNING SUMMARY
0400 00Z SFC ANALYSIS	1600 12Z SFC ANALYSIS
0412 00Z OAT AND TD CONTOUR T+24	1612 12Z OAT AND TD CONTOUR T+24
0424 00Z 850MB WBPT/PPTN T+24	1624 12Z 850MB WBPT/PPTN T+24
0436 00Z SFC PROGNOSIS T+24	1636 12Z SFC PROGNOSIS T+24
0448 06Z SCEXAS TAFS	1648 18Z SCEXAS TAFS
0500 00Z SFC ANALYSIS	1700 12Z SFC ANALYSIS
0512 00Z SFC PROGNOSIS T+24	1712 12Z SFC PROGNOSIS T+24
0524 00Z SFC PROGNOSIS T+48	1724 12Z SFC PROGNOSIS T+48
0536 06Z SCEXAS TAFS	1736 18Z SCEXA TAFS
0548 06Z GALE WARNING SUMMARY	1748 18Z GALE WARNING SUMMARY
0600 00Z SFC ANALYSIS	1800 12Z SFC ANALYSIS
0612 00Z SFC PROG T+24	1812 12Z SFC PROG T+24
0624 00Z JMC T+12	1824 12Z JMC T+12
0636 00Z JMC T+24	1836 12Z JMC T+24
0648 07Z SCEXA TAFS	1848 19Z SCEXA TAFS
0700 07Z SPARE SCEXA TAFS	1900 19Z SPARE SCEXA TAFS
0712 00Z SIG WINDS T+24	1912 12Z SIG WINDS T+24
0724 00Z SFC PROGNOSIS T+48	1924 12Z SFC PROGNOSIS T+48
0736 00Z SFC PROGNOSIS T+72	1936 12Z SFC PROGNOSIS T+72
0748 00Z SFC PROGNOSIS T+96	1948 12Z SFC PROGNOSIS T+96
0800 00Z SFC PROGNOSIS T+120	2000 12Z SFC PROGNOSIS T+120
0812 00Z THICKNESS/GPH ANALYSIS	2012 12Z THICKNESS/GPH ANALYSIS
0824 00Z SIG WINDS T+48	2024 12Z SIG WINDS T+48
0836 00Z SIG WINDS T+72	2036 12Z SIG WINDS T+72
0848 00Z SIG WINDS T+96	2048 12Z SIG WINDS T+96
0900 06Z SFC ANALYSIS	2100 18Z SFC ANALYSIS
0912 00Z THICKNESS/GPH ANALYSIS	2112 12Z THICKNESS/GPH ANALYSIS
0924 00Z THICKNESS/GPH T+24	2124 12Z THICKNESS/GPH T+24
0936 00Z 850MB SPOT WINDS T+24	2136 12Z 850MB SPOT WINDS T+24
0948 00Z 700MB SPOT WINDS T+24	2148 12Z 700MB SPOT WINDS T+24
1000 06Z SFC ANALYSIS	2200 18Z SFC ANALYSIS
1012 06Z SFC PROGNOSIS T+24	2212 18Z SFC PROGNOSIS T+24
1024 06Z REDUCED VIS T+24	2224 18Z REDUCED VIS T+24
1036 06Z 850MB WBPT/PPTN T+24	2236 18Z 850MB WBPT/PPTN T+24
1048 06Z OAT AND TD CONTOUR T+24	2248 18Z OAT AND TD CONTOUR T+24
1100 06Z SFC ANALYSIS	2300 18Z SFC ANALYSIS
1112 06Z SFC PROGNOSIS T+24	2312 18Z SFC PROGNOSIS T+24
1124 06Z SEA AND SWELL T+24	2324 18Z SEA AND SWELL T+24
1136 00Z THICKNESS/GPH T+24	2336 12Z THICKNESS/GPH T+24
1148 00Z GALE WARNING SUMMARY	2348 12Z GALE WARNING SUMMARY
FREQS	
2618.5KHZ	
4610.0KHZ	
8040.0KHZ	
110885.5KHZ	

Figure 11.6: The station schedule of GYA.

For first experiments with facsimile reception are suitable strong local stations. Here in Europe it is the German station DDHx, which is active on frequencies 3855.0, 7880.0 a 13 882,5 kHz. As already announced, station always receive in USB mode and tune it 1900 Hz below. Therefore DDH3 tune on 3853.1 kHz. Its speed is 120 lpm and IOC 576.

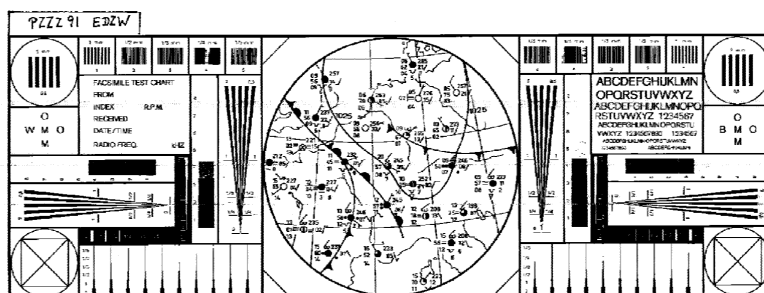

Figure 11.7: Test chart of DDH3 transmitted daily in 11:10 UTC.

Another station is an English GYA broadcasting from Northwood (120/576) on frequencies 2618.5, 4610.0, 8040.0, 11085.5 kHz (active are at least two channels simultaneously).

From long distance stations can be received almost daily Tokyo station JMH4. Of the three transmitters is the best JMH4 on 13597.0 kHz with 5 kW output power. Besides the usual synoptic chart there are available satellite imagery too.

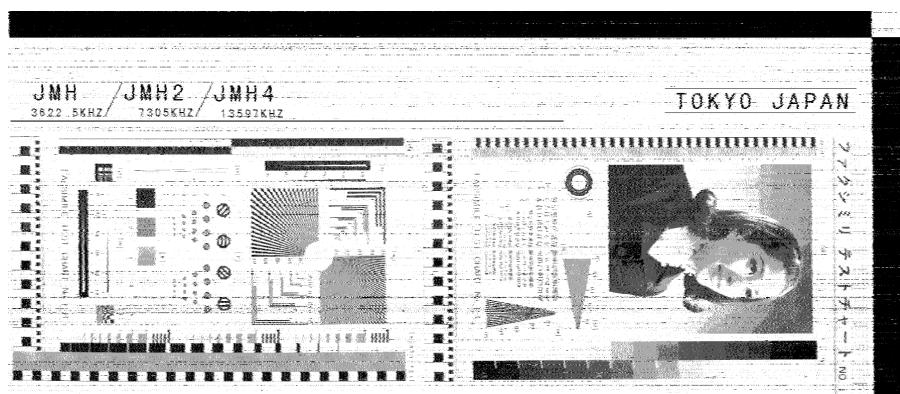

Figure 11.8: Test chart from JMH4 available daily at 13:00 UTC.

Next Tokyo station is JJC, it is Kyodo News Agency. Transmission speed is 60 lpm and IOC 576, sometimes 120 lpm when weather charts are posted. The station broadcast simultaneously on several frequencies: 12745.5, 16971.0, 17069.6, 22542.0 kHz, by listening find the active frequency. Interestingly, the owner of JJC station was

in 1997 thinking about closure, if they find some other way for news distribution. It didn't stop yet and Kyodo News Agency still distributes newspapers via facsimile.



Figure 11.9: Typical JJC transmission.

For those who deal with DX radio reception on the HF While listening to the interesting DX will be rewarded by received image. Complete list of stations sorted by country or frequency see chapter 12.

The detail list of frequencies and station schedule can be find in publication *Marine Worldwide Radiofacsimile Broadcast Schedules*, which is published by the National Oceanic and Atmospheric Administration's (NOAA) and it's freely available to download.

Radiofacsimile Worldwide Marine Broadcast Schedules:

<http://www.nws.noaa.gov/om/marine/rfax.pdf>

Another excellent source of information for those who are interested in receiving of meteorological data is the website of the *World Meteorological Organizations W.M.O.* Besides general information about meteorology there are lists of frequencies and schedules, not only for the fax, but also for other professional stations which use for distribution radio teletype (RTTY), NAVTEX and other types of digital modes.

World Meteorological Organization: <http://www.wmo.ch/>

11.4 Satellite imagery retransmission

Following list is compiled from It's the list of stations retransmitting meteo-satellites imagery. All listed stations transmit in 120 lpm and IOC 576.

UTC	Station	Ident.	Frequencies (kHz)	Note
00:34	Hawai, USA	KVM70	9982.5; 11090; 16135	East pacific GOES IR
00:48	Hawai, USA	KVM70	9982.5; 11090; 16135	SW pacific GOES IR
01:01	Halifax, Canada	CFH	122.5; 4271; 6496.4; 10536; 13510	IR
01:10	Tokyo, Japan	JMHx	3622.5; 7795; 13988.5	MTSAT
01:20	Taipei, China	BMF	4616; 8140; 13900; 18560	GMS
01:43	California, USA	NMC	8682; 12786; 17151.2; 22527	NE GOES IR
01:54	California, USA	NMC	8682; 12786; 17151.2; 22527	Pacific GOES IR
02:00	Lousiana, USA	NMG	4317.9; 8503.9; 12789.9; 17146.4	Tropical GOES IR
03:51	Massachusetts, USA	NMF	4235; 6340.5; 9110; 12750	
05:06	Alaska, USA	NOJ	2054; 4298; 8459; 12412.5	GOES IR
06:35	Hawai, USA	KVM70	9982.5; 11090; 16135	East pacific GOES IR
06:49	Hawai, USA	KVM70	9982.5; 11090; 16135	SW pacific GOES IR
07:10	Tokyo, Japan	JMHx	3622.5; 7795; 13988.5	MTSAT
07:20	Taipei, China	BMF	4616; 8140; 13900; 18560	GMS
07:37	California, USA	NMC	8682; 12786; 17151.2; 22527	Tropical GOES IR
08:00	Lousiana, USA	NMG	4317.9; 8503.9; 12789.9; 17146.4	Tropical GOES IR
09:06	Hawai, USA	KVM70	9982.5; 11090; 16135	Pacific GOES IR
09:08	California, USA	NMC	8682; 12786; 17151.2; 22527	Pacific GOES IR
09:43	Hawai, USA	KVM70	9982.5; 11090; 16135	Tropical GOES IR
09:51	Massachusetts, USA	NMF	4235; 6340.5; 9110; 12750	
10:22	Halifax, Canada	CFH	122.5; 4271; 6496.4; 10536; 13510	IR
11:17	Alaska, USA	NOJ	2054; 4298; 8459; 12412.5	GOES IR
11:30	Playa Ancha, Chile	CBV	4228; 8677; 17146.4	
12:32	Hawai, USA	KVM70	9982.5; 11090; 16135	East pacific GOES IR
12:48	Hawai, USA	KVM70	9982.5; 11090; 16135	SW pacific GOES IR
13:10	Tokyo, Japan	JMHx	3622.5; 7795; 13988.5	MTSAT
13:20	Taipei, China	BMF	4616; 8140; 13900; 18560	GMS
14:00	Lousiana, USA	NMG	4317.9; 8503.9; 12789.9; 17146.4	Tropical GOES IR
14:03	California, USA	NMC	8682; 12786; 17151.2; 22527	NE GOES IR
14:14	California, USA	NMC	8682; 12786; 17151.2; 22527	Pacific GOES IR
15:03	Massachusetts, USA	NMF	4235; 6340.5; 9110; 12750	
16:45	Playa Ancha, Chile	CBV	4228; 8677; 17146.4	

UTC	Station	Ident.	Frequencies (kHz)	Note
17:06	Alaska, USA	NOJ	2054; 4298; 8459; 12412.5	GOES IR
18:35	Hawai, USA	KVM70	9982.5; 11090; 16135	East pacific GOES IR
18:49	Hawai, USA	KVM70	9982.5; 11090; 16135	SW pacific GOES IR
19:02	California, USA	NMC	8682; 12786; 17151.2; 22527	Tropical GOES IR
19:10	Tokyo, Japan	JMHx	3622.5; 7795; 13988.5	MTSAT
19:20	Taipei, China	BMF	4616; 8140; 13900; 18560	GMS
19:30	Playa Ancha, Chile	CBV	4228; 8677; 17146.4	
20:00	Lousiana, USA	NMG	4317.9; 8503.9; 12789.9; 17146.4	Tropical GOES IR
21:06	Hawai, USA	KVM70	9982.5; 11090; 16135	Pacific GOES IR
21:13	California, USA	NMC	8682; 12786; 17151.2; 22527	Pacific GOES IR
21:43	Hawai, USA	KVM70	9982.5; 11090; 16135	Tropical GOES IR
21:51	Massachusetts, USA	NMF	4235; 6340.5; 9110; 12750	
23:17	Alaska, USA	NOJ	2054; 4298; 8459; 12412.5	GOES IR
23:25	Playa Ancha, Chile	CBV	4228; 8677; 17146.4	

It depends on your own position if you have interest in reception of images from these stations. For long distance stations should not be reception conditions so good every day. Their images for me in Europe is not interesting for weather forecast, but there are images of hurricanes, typhoons and other unusual weather phenomena.

11.4.1 Meteorologic satellites

If you are interested in reception of satellite imagery, there is few basic informations.

For amateur reception it is possible to use NOAA satellites on low Earth orbit. These satellites transmit in 137MHz band in WEFAX mode with amplitude modulation, so an sound card can be used as signal decoder with some dedicated software like JVComm32 or WXtoIMG. For the best reception should be used a receiver with 30 kHz intermediate frequency (IF) width, which unfortunately common receivers and TRXes don't support. The narrower IF causes image distortion and receiver for wideband FM (about 200 kHz) is not very suitable due to more noise that affecting signal. Also it is necessary to use an antenna with right-handed circular polarization as *turnstile antenna* (crossed dipoles) or *QFH* (*Quadrifillar Helix Antenna*).

Satellites NOAA, MetOp and Fengyun are carrying high resolution scanners and digital transmitters – *HRPT* (*High Resolution Image Transmission*). They broadcast on 1.6GHz band, but used system is digital and for data reception must be used band converter, special modem and main difficulty rests in need of antenna aiming. A computer controlled rotator is needed for aiming of azimuth and elevation.

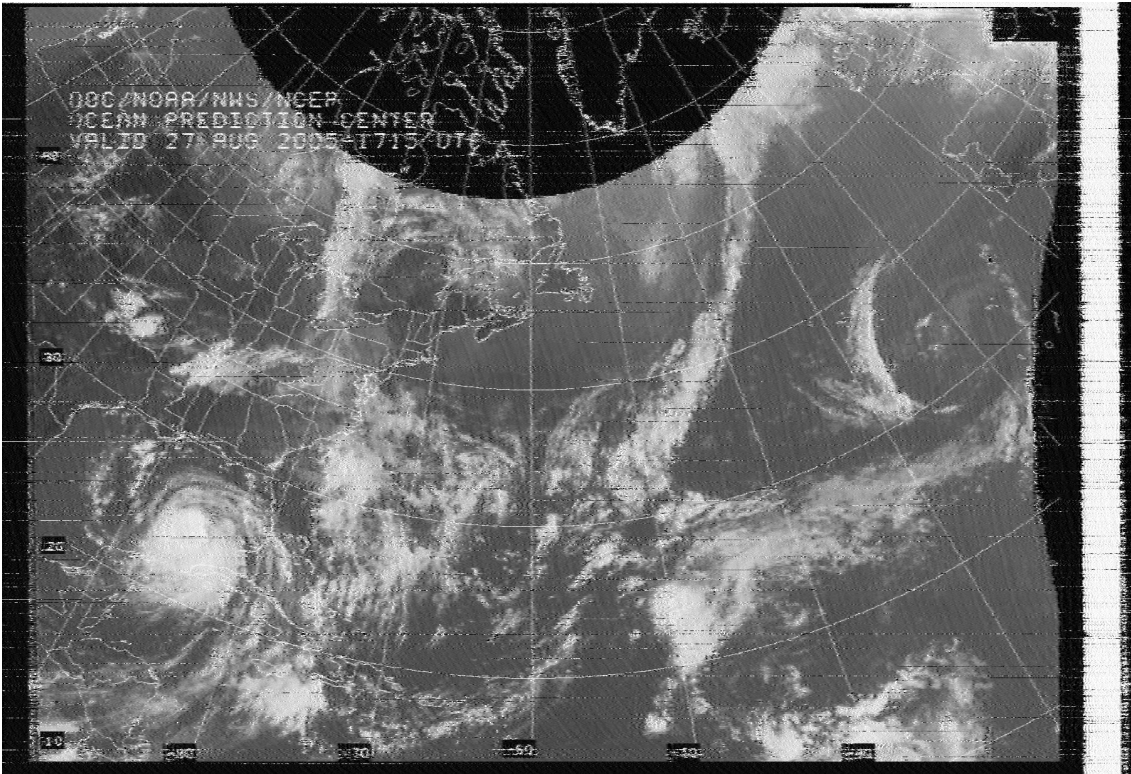

Figure 11.10: Retransmission of satellite image from Boston NMF station received on 12.750 kHz, hurricane Katrina is devastating Mexican gulf

Next option is a reception of geostationary satellites of Meteosat and GOES family. The analog WEFAX broadcast in 1.6GHz band was discontinued. For analog WEFAX reception could be used NOAA receiver with band converter and dish or yagi antenna.

The follower of the analog broadcast is new system *MSG (Meteosat Second Generation)*, it is fully operational since 2004. Digital data *LRIT (Low Rate Information Transmission)* and *HRIT (High Rate Information Transmission)* are broadcast via television transponder EuroBird9 (Ku band 10.7 – 12.75 GHz) on 11,976.82 MHz (EUMETCAST). An extension PCI card for DVB-S reception is used for data reception, e.g. SkyStar2 card for PCI or external version for USB. The data are decoded with tq-TELLICAST software. The disadvantage is that almost all data is distributed encrypted, so it is necessary to register at Eumetsat provider and buy the hardware decoding key. The price for hobby purposes is €100 (software is for €60 and key is for €40). There are also higher demands on PC configuration: 2GHz CPU, 1 GB RAM and 36 GB hard disk.

The radiometer of Meteosat 8 and 9 provides images in 11 spectral channels in 3 km/pixel resolution and in *HRV (High Resolution Visible)* channel it is 1 km/pixel, although in regard to slant projection of the Earth's surface the resolution for Europe

and Globe edges is lower. Image data (*High Rate SEVIRI*) have a standard size 3712×3712 pixels and for HRV it is 5568×11136 pixels. Data from satellite are send first to the primary station in German Darmstadt and then they are processed and they are distributed via EuroBird 9.

The Meteosat 9 provides image of Earth globe every 15 minutes, the Meteosat 8 sends data every 5 minutes (Rapid Scanning Service), but only European part of globe is sent. In addition to these data via EUMETCAST are broadcast further meteorological products, such as NOAA and MetOp HRPT imagery and processed data from other satellite sensors (infrared, microwaves,...).

11.4.2 Essential Services

The unencrypted data from Meteosat 9 and Meteosat 7 are transmitted every six hours, also GOES and MTSAT-1R is available every 3 hours.

Satellite	Interval	Transmission times (UTC)
Meteosat 9 HRIT/LRIT	6 hours	05:45, 11:45, 17:45, 23:45
Meteosat 7	6 hours	00:00, 06:00, 12:00, 18:00
GOES 9, 10, 12; MTSAT-1R	3 hours	00:00, 03:00, 06:00, 09:00, 12:00, 15:00, 18:00, 21:00

Table 11.2: Essential services data.

11.5 Hamradio facsimile operations

The facsimile operation did not spread as SSTV in the past years. The reason for this is using of complex mechanical scanners and recorders and also a relatively long time of image transfer. A little development came with the computer software and cheap interfaces, but it is very rare to heard amateur fax on bands.

The use of facsimile fits for very high resolution images, which is better than any SSTV mode. The number of lines for image is not given, but aspect ratio 4:3 should be used. Hamradio operators use IOC 576 or 288 and speed 120 lpm or 240 lpm, the usage of other modes depends on agreement of both parties. A report is given in common RST code (*Readability, Strenght, Tone*).

An opportunity to receive rare facsimile amateur stations is 3rd weekend in August, when *The International HF – FAX – Contest by DARC* is active. Those who are interested in this kind of communication mode may also try to obtain a diploma awarded by the DARC for two-way contacts.

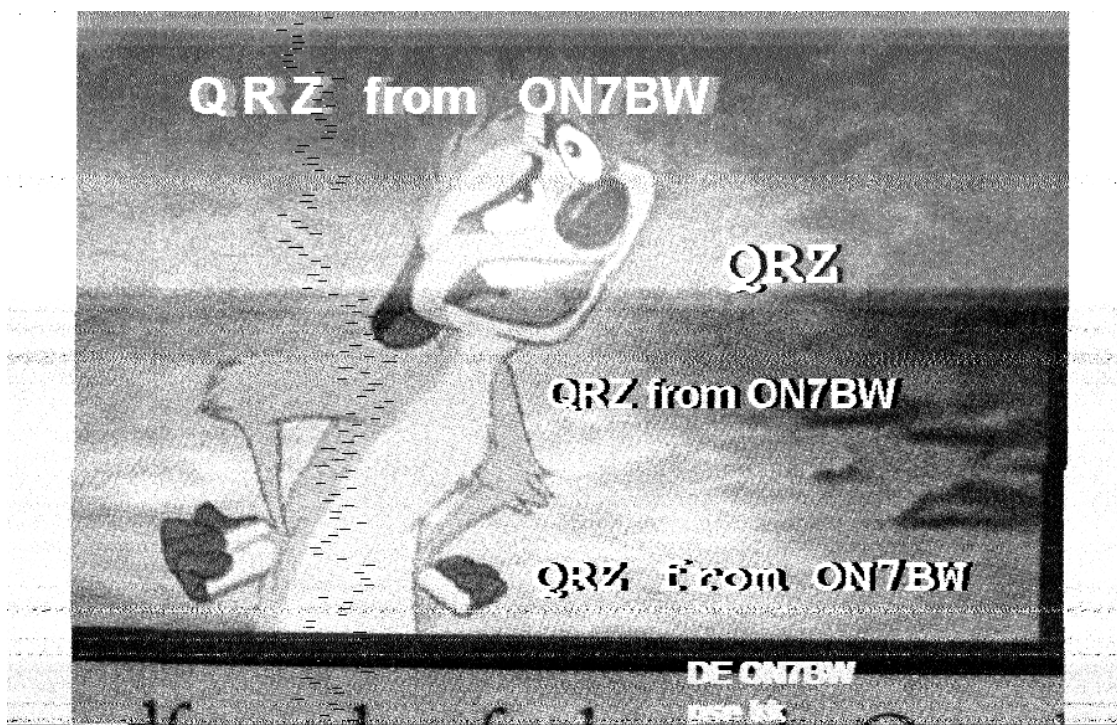

Figure 11.11: Hamradio facsimile from ON7BW received on 14MHz band, speed 240 lpm, IOC 288.

11.5.1 EU – FAX – Diplom

The diplom is award for two-way facsimile contacts with European countries. There are three degrees for QSO with 10 prefixes in 5 countries, 20 prefixes in 10 countries and 40 prefixes in 20 countries. European countries are given by WAE list. Valid QSOs are from 1/1/1980 and QSL cards must have note *2-WAY FAX*. A confirmed list of QSL cards and €5 send to: *DARC FAX Manager, Werner Ludwig DF5BX, Post Box 1270, D-49110 Georgmarienshutte, Germany.*

11.5.2 The International HF – FAX – Contest by DARC

The contest is organized by the Deutscher Amateur Radio Club. Ongoing 3rd weekend of the August, starts at 8:00 UTC on Saturday and ends on Sunday at 20:00 UTC. It progress on all HF bands except the WARC. Assessed by two classes – listeners and one operator. All QSOs must be done in facsimile mode and image calls should include *CQ FAX TEST*. Report the RST and the number of connections from 001. Any QSO is a point valued, multipliers are countries WAE/DXCC and districts W, VE, and JA. QSO with a same station are valid on more bands. The

log should be sent within 2 weeks after the contest to: *Werner Ludwig DF5BX, Post Box 1270, D-49110 Georgsmarienshuette, Germany*, email: `df5bx@dark.de`.

11.6 International facsimile standard recommendation

1. Drum speed:
60, 90, 120, 240 revolutions per minute, if speeds greater than 120 rpm are used, they should be multiples of 60 rpm.
2. Diameter of drum:
152 mm, in the case of flat-bed scanners this will be length of the scanning line (including the dead sector).
3. Index of co-operation (IOC):
 - ▷ 576 for minimum black or white picture elements of 0.4 mm and
 - ▷ 288 for minimum picture elements of 0.7 mm.
4. Length of drum:
the length of the drum should be at least 550 mm
5. Spanning density
Scanning density = IOC / diameter of drum
It is approximately: 4 lines per mm for index 576, 2 lines per mm for index 288.
6. Direction of scanning:
at the transmitter, the plane (developed in the case of drum transmitter) of the message area is scanned along lines running from left to right commencing in the left hand corner at the bottom and this is equivalent of scanning over a left hand helix.
7. Dead sector:
4.5% \pm 0.5% of the length of the scanning line. The signal transmitted during the passage of the dead sector should correspond to white but it is permitted that a black pulse be transmitted within and not exceeding one half length of the dead sector.
8. Selection of index of co-operation:
a five second transmission of alternating black and white signal at 300 Hz for index 576, 675 Hz for index 288. The envelopes of the signals transmitted will be roughly rectangular.
9. Synchronization:
the scanning speed should be maintained within 5 part in 10⁶ of the normal value.
10. Starting recorders:
recorders should be designed to start upon receipt of either the index selection signal or the phasing signal and no special signal for starting will be transmitted.
11. Phasing:

- a 30 second transmission of alternating white and black signal at the following frequencies:
- ▷ 1.0 Hz for speed of 60 rpm,
 - ▷ 1.5 Hz for speed of 90 rpm,
 - ▷ 2.0 Hz for speed of 120 rpm.
12. Adjustment of recording levels:
adjustment of recording level when used should be effected by reference to phasing signal.
13. Stopping recorders:
a 5 second transmission of alternating black and white signals at 450 Hz followed by 10 seconds of signals corresponding to continuous black.
14. Modulation characteristics
- ▷ Amplitude Modulation
The maximum amplitude of the carrying frequency should correspond to the transmission of signal black. Value of the carrying frequency: 1800 Hz.
 - ▷ Modulation by frequency deviation
 - ▷ Value of central frequency: 1900 Hz.
 - ▷ Value of frequency for black: 1500 Hz.
 - ▷ Value of frequency for white: 2300 Hz.The frequency for black and white should not vary by over 8 Hz over a period of 30 s and by more than 16 Hz over a period of 15 minutes.
15. Levels of signals in case of AM:
receiving equipment should accept any level between +5 dB and -20 db, zero reference level corresponding to a power of one milliwatt dissipated in a resistance of 600 ohms.
16. Contrast ratio
contrast ratio for picture signals and control signals will be the same for any transmission and will be between 12 and 25 dB.
17. Facsimile transmission of meteorological charts over radio circuits:
- ▷ When frequency modulation of the sub-carrier is employed for the facsimile transmission of meteorological charts over radio circuits, the following characteristics should be used:
 - ▷ Centre frequency: 1900 Hz.
 - ▷ Frequency corresponding to black: 1500 Hz.
 - ▷ Frequency corresponding to white: 2300 Hz.
 - ▷ When direct frequency modulation (FSK) is employed for the facsimile transmission of meteorological charts over radio circuits, the following characteristics apply:
 - ▷ Decametric waves (3 MHz – 30 MHz)
 - ▷ Centre frequency: f_0 .
 - ▷ Frequency corresponding to black: $f_0 - 400$ Hz.

- ▷ Frequency corresponding to white: $f_0 + 400$ Hz.
- ▷ Kilometric waves (30 kHz – 300 kHz)
 - ▷ Centre frequency: f_0 .
 - ▷ Frequency corresponding to black: $f_0 - 150$ Hz.
 - ▷ Frequency corresponding to white: $f_0 + 150$ Hz.

12

List of professional stations

There is list of HF professional stations. Be sure to tune in USB mode for 1.9 kHz lower! Time values are given in UTC *Coordinated Universal Time*.

12.1 Europe

12.1.1 Athens, Greece

Ident.	Frequency	lpm	IOC	Power	Note
SVJ4	4,481.0 kHz	120	576	8 kW	08:45–10:44
SVJ4	8,105.0 kHz	120	576	8 kW	08:45–10:44

Broadcast time: 08:45–10:44.

12.1.2 Hamburg/Pinnenberg, Germany

Ident.	Frequency	lpm	IOC	Power	Note
DDH3	3,855.0 kHz	120	576	10 kW	
DDK3	7,880.0 kHz	120	576	20 kW	
DDK6	13,882.5 kHz	120	576	20 kW	

Broadcast time: 04:30–11:45, 15:20–22:00.

12.1.3 Roma, Italy

Ident.	Frequency	lpm	IOC	Power	Note
IMB51	4,777.5 kHz	120	576	5 kW	
IMB55	8,146.6 kHz	120	576	5 kW	
IMB56	13,597.4 kHz	120	576	5 kW	

Broadcast time: continuous.

12.1.4 Moscow, Russia

Ident.	Frequency	lpm	IOC	Power	Note
	3,830.0 kHz	90, 120	576, 288		
	5,008.0 kHz	90, 120	576, 288		
	6,987.0 kHz	90, 120	576, 288		
	7,695.0 kHz	90, 120	576, 288		
RCC76	10,980.0 kHz	90, 120	576, 288		
RDD78	11,617.0 kHz	90, 120	576, 288		
RCC76	10,980.0 kHz	90, 120	576, 288		

Broadcast time: continuous.

12.1.5 Murmansk, Russia

Ident.	Frequency	lpm	IOC	Power	Note
RBW41	5,336.0 kHz	90, 120	576		
RBW41	6,445.5 kHz	90, 120	576		main frequency
RBW41	7,908.8 kHz	90, 120	576		19:00–06:00
RBW48	10,130.0 kHz	90, 120	576		06:00–19:00

Broadcast time: 07:00–08:00, 14:00–14:30, 18:50, 20:00.

12.1.6 Northwood, The United Kingdom

Ident.	Frequency	lpm	IOC	Power	Note
GYA	2,618.5 kHz	120	576	10 kW	20:00–06:00
GYA	4,610.0 kHz	120	576	10 kW	
GYA	8,040.0 kHz	120	576	10 kW	
GYA	11,086.5 kHz	120	576	10 kW	06:00–20:00

Broadcast time: continuous, at least on two frequencies.

12.2 Africa

12.2.1 Cape Naval, South Africa

Ident.	Frequency	lpm	IOC	Power	Note
ZSJ	4,014.0 kHz	120	576	10 kW	pouze od 16 h do 06 h
ZSJ	7,508.0 kHz	120	576	10 kW	
ZSJ	13,538.0 kHz	120	576	10 kW	
ZSJ	18,238.0 kHz	120	576	10 kW	pouze od 06 h do 16 h

Broadcast time: 04:30–11:00, 15:30, 17:00, 22:30.

12.3 Asia

12.3.1 Beijing, China

Ident.	Frequency	lpm	IOC	Power	Note
BAF6	5,526.9 kHz	120	576	6-8 kW	
BAF36	8,121.9 kHz	120	576	6-8 kW	
BAF4	10,116.9 kHz	120	576	10 kW	
BAF8	14,366.9 kHz	120	576	15 kW	
BAF9	16,025.9 kHz	120	576	?? kW	
BAF33	18,236.9 kHz	120	576	6-8 kW	

Broadcast time: 00:08–11:58, 13:40, 19:04–22:40.

12.3.2 Beijing, China

Ident.	Frequency	lpm	IOC	Power	Note
3SD	8,461.9 kHz	120	576	10 kW	
3SD	12,831.9 kHz	120	576	10 kW	
3SD	16,903.9 kHz	120	576	30 kW	

Broadcast time: 07:55, 11:30.

12.3.3 Shanghai, China

Ident. Frequency lpm IOC Power Note

BDF	3,241.0 kHz	120	576
BDF	5,100.0 kHz	120	576
BDF	7,420.0 kHz	120	576
BDF	11,420.0 kHz	120	576
BDG	18,940.0 kHz	120	576

Broadcast time: 00:10, 01:30, 18:10, 20:30.

12.3.4 New Delhi, India

Ident. Frequency lpm IOC Power Note

ATP57	7,404.9 kHz	120	576	10 kW	14:30–02:30
ATP65	14,842.0 kHz	120	576	10 kW	02:30–14:30

Broadcast time: continuous.

12.3.5 Tokyo, Japan

Ident. Frequency lpm IOC Power Note

JMH	3,622.5 kHz	120	576	5 kW
JMH2	7,305.0 kHz	120	576	5 kW
JMH4	13,597.0 kHz	120	576	5 kW

Broadcast time: continuous.

12.3.6 Pevek, Chukotka peninsula

Ident. Frequency lpm IOC Power Note

	148.0 kHz	90	576
--	-----------	----	-----

Broadcast time: 05:30–07:30, 11:30–13:30, 14:30–16:30.

12.3.7 Taipei, China

Ident. Frequency lpm IOC Power Note

BMF	4,616.0 kHz	120	576	10 kW	
BMF	5,250.0 kHz	120	576	10 kW	
BMF	8,140.0 kHz	120	576	10 kW	
BMF	13,900.0 kHz	120	576	10 kW	
BMF	18,560.0 kHz	120	576	10 kW	

Broadcast time: 00:40–10:10, 13:10–22:10.

12.3.8 Seoul, Republic of Korea

Ident. Frequency lpm IOC Power Note

HLL1	3,585.0 kHz	120	576	3 kW	
HLL2	5,857.5 kHz	120	576	3 kW	
HLL3	7,433.5 kHz	120	576	3 kW	
HLL4	9,165.0 kHz	120	576	3 kW	
HLL5	13,570.0 kHz	120	576	3 kW	

Broadcast time: 00:00–10:40, 12:00–22:40.

12.3.9 Bangkok, Thailand

Ident. Frequency lpm IOC Power Note

HSW64	7,396.8 kHz	120	576	3 kW	
-------	-------------	-----	-----	------	--

Broadcast time: 00:50–06:00, 07:20–10:20, 13:00, 17:00, 23:00.

12.3.10 Kyodo News Agency, Japan

Ident. Frequency lpm IOC Power Note

JJC	4,316.0 kHz	60	576	5 kW	meteo. maps 120 lpm
JJC	8,467.5 kHz	60	576	10 kW	meteo. maps 120 lpm
JJC	12,745.5 kHz	60	576	15 kW	meteo. maps 120 lpm
JJC	16,971.0 kHz	60	576	15 kW	meteo. maps 120 lpm
JJC	17,069.6 kHz	60	576	15 kW	meteo. maps 120 lpm
JJC	22,542.0 kHz	60	576	15 kW	meteo. maps 120 lpm

Broadcast time: 01:45–07:45, 11:00–11:30, 13:35–22:15.

12.3.11 Kyodo News Agency, Singapore

Ident.	Frequency	lpm	IOC	Power	Note
9VF/252	16,035.0 kHz	60	576	10 kW	07:40–10:10, 14:15–18:15
9VF/252	17,430.0 kHz	60	576	10 kW	07:40–10:10, 14:15–18:15

Broadcast time: 07:40–10:10, 14:15–18:15.

12.3.12 Northwood, Persian Gulf Base

Ident.	Frequency	lpm	IOC	Power	Note
GYA	6,834.0 kHz	120	576	10 kW	18:00–08:00
GYA	14,436.0 kHz	120	576	10 kW	nepřetržitý provoz
GYA	18,261.0 kHz	120	576	10 kW	08:00–18:00

12.4 South America

12.4.1 Rio de Janeiro, Brazil

Ident.	Frequency	lpm	IOC	Power	Note
PWZ-33	12,665.0 kHz	120	576	1 kW	
PWZ-33	16,978.0 kHz	120	576	1 kW	

Broadcast time: 07:45–08:50.16:30–17:35.

12.4.2 Valparaiso Playa Ancha, Chile

Ident.	Frequency	lpm	IOC	Power	Note
CBV	4,228.0 kHz	120	576	1 kW	
CBV	8,677.0 kHz	120	576	1 kW	
CBV	17,146.4 kHz	120	576	1 kW	

Broadcast time: 11:15–23:25.

12.5 North America

12.5.1 Halifax, Nova Scotia Canada

Ident. Frequency lpm IOC Power Note

CFH	122.5 kHz	120	576	10 kW	
CFH	4,271.0 kHz	120	576	6 kW	
CFH	6,496.4 kHz	120	576	6 kW	
CFH	10,536.0 kHz	120	576	6 kW	
CFH	13,510.0 kHz	120	576	6 kW	

Broadcast time: continuous.

12.5.2 Iqaluit, NWT Canada

Ident. Frequency lpm IOC Power Note

VFF	3,253.0 kHz	120	576	5 kW	21:00–23:30
VFF	7,710.0 kHz	120	576	5 kW	00:10–09:00

Broadcast time: since middle of June till the end of November.

12.5.3 Resolute, NWT Canada

Ident. Frequency lpm IOC Power Note

VFR	3,253.0 kHz	120	576	5 kW	00:10–09:00
VFR	7,710.0 kHz	120	576	5 kW	21:00–23:30

Broadcast time: since middle of June till the end of November.

12.5.4 Sydney, Nova Scotia Kanada

Ident. Frequency lpm IOC Power Note

VCO	4,416.0 kHz	120	576		11:21, 11:42, 17:41
VCO	6,915.0 kHz	120	576		22:00, 23:31

Broadcast time: by frequency.

12.5.5 Kodiak, Alaska USA

Ident.	Frequency	lpm	IOC	Power	Note
NOJ	2,054.0 kHz	120	576	7.5 kW	
NOJ	4,298.0 kHz	120	576	7.5 kW	
NOJ	8,459.0 kHz	120	576	7.5 kW	
NOJ	12,412.5 kHz	120	576	7.5 kW	

Broadcast time: 04:00–11:59, 16:00–00:18.

12.5.6 Pt. Reyes, California USA

Ident.	Frequency	lpm	IOC	Power	Note
NMC	4,346.0 kHz	120	576	4 kW	01:40–16:08
NMC	8,682.0 kHz	120	576	4 kW	
NMC	12,786.0 kHz	120	576	4 kW	
NMC	17,151.2 kHz	120	576	4 kW	
NMC	22,527.0 kHz	120	576	4 kW	18:40–23:56

Broadcast time: continuous.

12.5.7 New Orleans, Louisiana USA

Ident.	Frequency	lpm	IOC	Power	Note
NMG	4,317.9 kHz	120	576	4 kW	
NMG	8,503.9 kHz	120	576	4 kW	
NMG	12,789.9 kHz	120	576	4 kW	
NMG	17,146.4 kHz	120	576	4 kW	12:00–20:45

Broadcast time: 00:00–08:45, 12:00–20:45.

12.5.8 Boston, Massachusetts USA

Ident.	Frequency	lpm	IOC	Power	Note
NMF	4,235.0 kHz	120	576	4 kW	02:30–10:28
NMF	6,340.5 kHz	120	576	4 kW	
NMF	9,110.0 kHz	120	576	4 kW	
NMF	12,750.0 kHz	120	576	4 kW	14:00–22:28

Broadcast time: 02:30–10:28, 14:00–22:28.

12.5.9 Inuvik, Canada

Ident.	Frequency	lpm	IOC	Power	Note
VFA	8,457.8 kHz	120	576	1 kW	02:00, 16:30

Broadcast time: 02:00, 16:30.

12.6 Australia and Oceania

12.6.1 Charleville, Australia

Ident.	Frequency	lpm	IOC	Power	Note
VMC	2,628.0 kHz	120	576	1 kW	09:00–19:00
VMC	5,100.0 kHz	120	576	1 kW	
VMC	11,030.0 kHz	120	576	1 kW	
VMC	13,920.0 kHz	120	576	1 kW	
VMC	20,469.0 kHz	120	576	1 kW	19:00–09:00

Broadcast time: continuous.

12.6.2 Wiluna, Australia

Ident.	Frequency	lpm	IOC	Power	Note
VMW	5,755.0 kHz	120	576	1 kW	11:00–21:00
VMW	7,535.0 kHz	120	576	1 kW	
VMW	10,555.0 kHz	120	576	1 kW	
VMW	15,615.0 kHz	120	576	1 kW	
VMW	18,060.0 kHz	120	576	1 kW	21:00–11:00

Broadcast time: continuous.

12.6.3 Wellington, New Zealand

Ident.	Frequency	lpm	IOC	Power	Note
ZKLF	3,247.4 kHz	120	576	5 kW	09:45–17:00
ZKLF	5,807.0 kHz	120	576	5 kW	
ZKLF	9,459.0 kHz	120	576	5 kW	
ZKLF	13,550.5 kHz	120	576	5 kW	
ZKLF	16,340.1 kHz	120	576	5 kW	21:45–05:00

Broadcast time: 00:00–04:00, 09:00–16:00, 21:00–23:00 (beginning every whole hour).

12.6.4 Honolulu, Hawaii USA

Ident.	Frequency	lpm	IOC	Power	Note
KVM70	9,982.5 kHz	120	576	5 kW	05:19–15:56
KVM70	11,090.0 kHz	120	576	5 kW	
KVM70	16,135.0 kHz	120	576	5 kW	17:19–03:56

Broadcast time: continuous, by frequency.

12.7 List by frequency

Freq. kHz	Ident. Call sign	Station	lpm	IOC	Note
122.5	CFH	Halifax, Nova Scotia Canada	120	576	
148.0		Pevek, Chukotka peninsula	90	576	
2,054.0	NOJ	Kodiak, Alaska USA	120	576	
2,618.5	GYA	Northwood, The United Kingdom	120	576	20:00–06:00
2,628.0	VMC	Charleville, Australia	120	576	09:00–19:00
3,241.0	BDF	Shanghai, China	120	576	
3,247.4	ZKLF	Wellington, New Zealand	120	576	09:45–17:00
3,253.0	VFF	Iqaluit, NWT Canada	120	576	21:00–23:30
3,253.0	VFR	Resolute, NWT Canada	120	576	00:10–09:00
3,585.0	HLL1	Seoul, Republic of Korea	120	576	
3,622.5	JMH	Tokyo, Japan	120	576	
3,830.0		Moscow, Russia	90, 120	576	IOC 288
3,855.0	DDH3	Hamburg/Pinnenberg, Germany	120	576	
4,228.0	CBV	Valparaiso Playa Ancha, Chile	120	576	
4,235.0	NMF	Boston, Massachusetts USA	120	576	02:30–10:28
4,271.0	CFH	Halifax, Nova Scotia Canada	120	576	
4,298.0	NOJ	Kodiak, Alaska USA	120	576	
4,316.0	JJC	Kyodo News Agency, Japan	60	576	meteo. maps 120 lpm
4,317.9	NMG	New Orleans, Louisiana USA	120	576	
4,346.0	NMC	Pt. Reyes, California USA	120	576	01:40–16:08
4,416.0	VCO	Sydney, Nova Scotia Kanada	120	576	11:21, 11:42, 17:41
4,481.0	SVJ4	Athens, Greece	120	576	08:45–10:44
4,610.0	GYA	Northwood, The United Kingdom	120	576	
4,616.0	BMF	Taipei, China	120	576	
4,777.5	IMB51	Roma, Italy	120	576	
5,008.0		Moscow, Russia	90, 120	576	IOC 288
5,100.0	BDF	Shanghai, China	120	576	
5,100.0	VMC	Charleville, Australia	120	576	
5,250.0	BMF	Taipei, China	120	576	
5,526.9	BAF6	Beijing, China	120	576	

Freq. kHz	Ident. Call sign	Station	lpm	IOC	Note
5,755.0	VMW	Wiluna, Australia	120	576	11:00–21:00
5,807.0	ZKLF	Wellington, New Zealand	120	576	
5,857.5	HLL2	Seoul, Republic of Korea	120	576	
6,340.5	NMF	Boston, Massachusetts USA	120	576	
6,496.4	CFH	Halifax, Nova Scotia Canada	120	576	
6,834.0	GYA	Northwood, Persian Gulf Base	120	576	18:00–08:00
6,915.0	VCO	Sydney, Nova Scotia Kanada	120	576	22:00, 23:31
6,987.0		Moscow, Russia	90, 120	576	IOC 288
7,305.0	JMH2	Tokyo, Japan	120	576	
7,396.8	HSW64	Bangkok, Thailand	120	576	
7,420.0	BDF	Shanghai, China	120	576	
7,433.5	HLL3	Seoul, Republic of Korea	120	576	
7,535.0	VMW	Wiluna, Australia	120	576	
7,695.0		Moscow, Russia	90, 120	576	IOC 288
7,710.0	VFF	Iqaluit, NWT Canada	120	576	00:10–09:00
7,710.0	VFR	Resolute, NWT Canada	120	576	21:00–23:30
7,880.0	DDK3	Hamburg/Pinnenberg, Germany	120	576	
8,040.0	GYA	Northwood, The United Kingdom	120	576	
8,105.0	SVJ4	Athens, Greece	120	576	08:45–10:44
8,121.9	BAF36	Beijing, China	120	576	
8,140.0	BMF	Taipei, China	120	576	
8,146.6	IMB55	Roma, Italy	120	576	
8,457.8	VFA	Inuvik, Canada	120	576	02:00, 16:30
8,459.0	NOJ	Kodiak, Alaska USA	120	576	
8,461.9	3SD	Beijing, China	120	576	
8,467.5	JJC	Kyodo News Agency, Japan	60	576	meteo. maps 120 lpm
8,503.9	NMG	New Orleans, Louisiana USA	120	576	
8,677.0	CBV	Valparaiso Playa Ancha, Chile	120	576	
8,682.0	NMC	Pt. Reyes, California USA	120	576	
9,110.0	NMF	Boston, Massachusetts USA	120	576	
9,165.0	HLL4	Seoul, Republic of Korea	120	576	

Freq. kHz	Ident. Call sign	Station	lpm	IOC	Note
9,459.0	ZKLF	Wellington, New Zealand	120	576	
9,982.5	KVM70	Honolulu, Hawaii USA	120	576	05:19–15:56
10,116.9	BAF4	Beijing, China	120	576	
10,536.0	CFH	Halifax, Nova Scotia Canada	120	576	
10,555.0	VMW	Wiluna, Australia	120	576	
10,980.0	RCC76	Moscow, Russia	90, 120	576	IOC 288
10,980.0	RCC76	Moscow, Russia	90, 120	576	IOC 288
11,030.0	VMC	Charleville, Australia	120	576	
11,086.5	GYA	Northwood, The United Kingdom	120	576	06:00–20:00
11,090.0	KVM70	Honolulu, Hawaii USA	120	576	
11,420.0	BDF	Shanghai, China	120	576	
12,412.5	NOJ	Kodiak, Alaska USA	120	576	
12,745.5	JJC	Kyodo News Agency, Japan	60	576	meteo. maps 120 lpm
12,750.0	NMF	Boston, Massachusetts USA	120	576	14:00–22:28
12,786.0	NMC	Pt. Reyes, California USA	120	576	
12,789.9	NMG	New Orleans, Louisiana USA	120	576	
12,831.9	3SD	Beijing, China	120	576	
13,510.0	CFH	Halifax, Nova Scotia Canada	120	576	
13,538.0	ZSJ	Cape Naval, South Africa	120	576	
13,550.5	ZKLF	Wellington, New Zealand	120	576	
13,570.0	HLL5	Seoul, Republic of Korea	120	576	
13,597.0	JMH4	Tokyo, Japan	120	576	
13,597.4	IMB56	Roma, Italy	120	576	
13,882.5	DDK6	Hamburg/Pinnenberg, Germany	120	576	
13,900.0	BMF	Taipei, China	120	576	
13,920.0	VMC	Charleville, Australia	120	576	
14,366.9	BAF8	Beijing, China	120	576	
14,436.0	GYA	Northwood, Persian Gulf Base	120	576	nepřetržitý provoz
14,842.0	ATP65	New Delhi, India	120	576	02:30–14:30
15,615.0	VMW	Wiluna, Australia	120	576	
16,025.9	BAF9	Beijing, China	120	576	

Freq. kHz	Ident. Call sign	Station	lpm	IOC	Note
16,035.0	9VF/252	Kyodo News Agency, Singapore	60	576	07:40–10:10, 14:15–18:15
16,135.0	KVM70	Honolulu, Hawaii USA	120	576	17:19–03:56
16,340.1	ZKLF	Wellington, New Zealand	120	576	21:45–05:00
16,903.9	3SD	Beijing, China	120	576	
16,971.0	JJC	Kyodo News Agency, Japan	60	576	meteo. maps 120 lpm
17,069.6	JJC	Kyodo News Agency, Japan	60	576	meteo. maps 120 lpm
17,146.4	CBV	Valparaiso Playa Ancha, Chile	120	576	
17,146.4	NMG	New Orleans, Louisiana USA	120	576	12:00–20:45
17,151.2	NMC	Pt. Reyes, California USA	120	576	
17,430.0	9VF/252	Kyodo News Agency, Singapore	60	576	07:40–10:10, 14:15–18:15
18,060.0	VMW	Wiluna, Australia	120	576	21:00–11:00
18,236.9	BAF33	Beijing, China	120	576	
18,261.0	GYA	Northwood, Persian Gulf Base	120	576	08:00–18:00
18,560.0	BMF	Taipei, China	120	576	
18,940.0	BDG	Shanghai, China	120	576	
20,469.0	VMC	Charleville, Australia	120	576	19:00–09:00
22,527.0	NMC	Pt. Reyes, California USA	120	576	18:40–23:56
22,542.0	JJC	Kyodo News Agency, Japan	60	576	meteo. maps 120 lpm

13

Computer image processing

This chapter focuses on a preparation of our broadcast contents – image and photo editing before the transmission.

There are available many programs for image editing, from complex editors for bitmap images to simple viewers with few editing functions. Some SSTV programs have also image editing functions.

The selection of suitable program depends on a user and his needs and although a control of programs can be slightly different the procedures described later are so general that it would not be a problem to achieve results using your favorite editor. The appropriate editor is generally any program for editing of raster/bitmap images, such as: GIMP, Paint Shop Pro, Adobe Photoshop, Pixel32,... Less suitable are vector image editors, such as: Corel Draw!, Inkscape, etc.

There are described some basic principles and functions, which are used in most common programs. Although some functions below are shown in GIMP, see sec. ??, it should not be problem for savvy user to find same functions in his favourite editor.

Later, see section ??, there are specific tutorials only for GIMP.

13.1 Image resizing

The SSTV uses a relative small resolution in comparison with images you can get from digital cameras, scanners or some internet galleries. So before transmission the image should be resized to conventional resolution 320×240 pixels. You can achieve this in almost all SSTV programs, but images sometimes haven't aspect ratio 4:3 or we want use only part of image. So it is useful to prepare your images before QSO.

The image resizing brings a little risk, see **image 13.1**, original image is test chart on **page 172**.

There is a result of two image scaling algorithms. The left image was scaled down by *nearest-neighbor interpolation*, when pixels in regular columns and rows are removed. But the *linear interpolation* was used for the right image. The difference is visible on the first sight, the nearest-neighbor method caused distortion and some

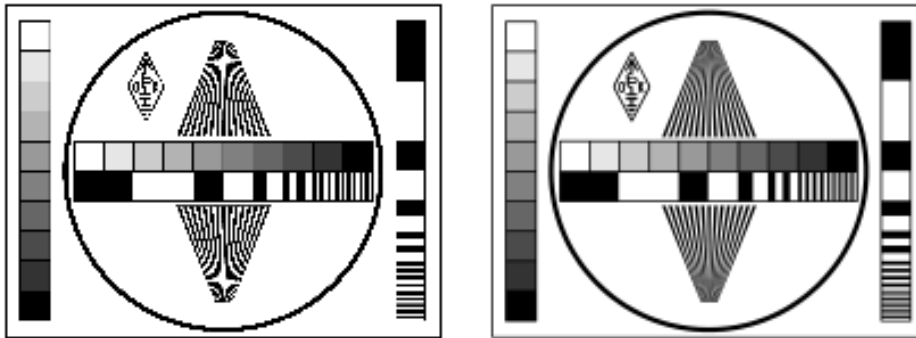

Figure 13.1: Results of image resizing with two different algorithms.

details are lost completely, e.g. thin lines are lost and on originally smooth curves are stair-like lines more evident. The linear interpolation is more considerate to details, but it depends on amount of decreasing and sometimes there should arise a *moiré*, here on the raster of changing white and black stripes.

Almost every image editing software give an option for used scaling method, so choose linear interpolation (or bilinear or bicubic). A raster image for interpolation must have at least 16bit color depth, on indexed images with 256 or less colors it doesn't work, but you can convert them to more colors temporary and then back.

13.2 Color adjustment

Basic tools for the color adjustment can edit image contrast, brightness, color saturation and hue. The advanced tools are *curves adjustment* and *image histogram*.

The histogram is a representation of the distributions of colors in an image (see **pic. 13.2**). It is bar graph and there is representation of the tonal variations on the horizontal axis and the vertical axis represents the number of pixel in the particular tone.

In digital photography, you can easily review exposure by histogram. If the image is underexposed the amount of darker pixels lays on left side of graph (more darker pixels), vice-versa for overexposed images there is high number of lighter pixels on right side. It is possible to check exposure in the digital camera menu and take snapshot again, of course unless the image wasn't dark or light in principle.

The ideal case is if the luminance is wide-spread inside the luminance range. For low contrast the luminance values are spread only over smaller range of luminance. The histogram *equalization* can help to adjust contrast of image – luminance is spread over all range. For the result of histogram equalization see **pic. 13.3**.

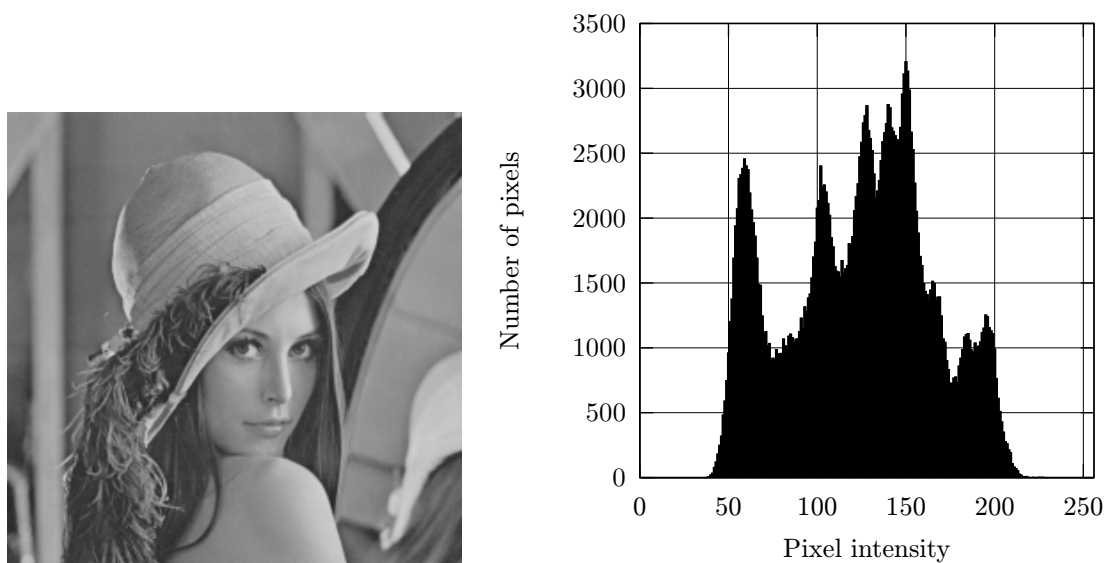

Figure 13.2: The image histogram for 256 brightness values.

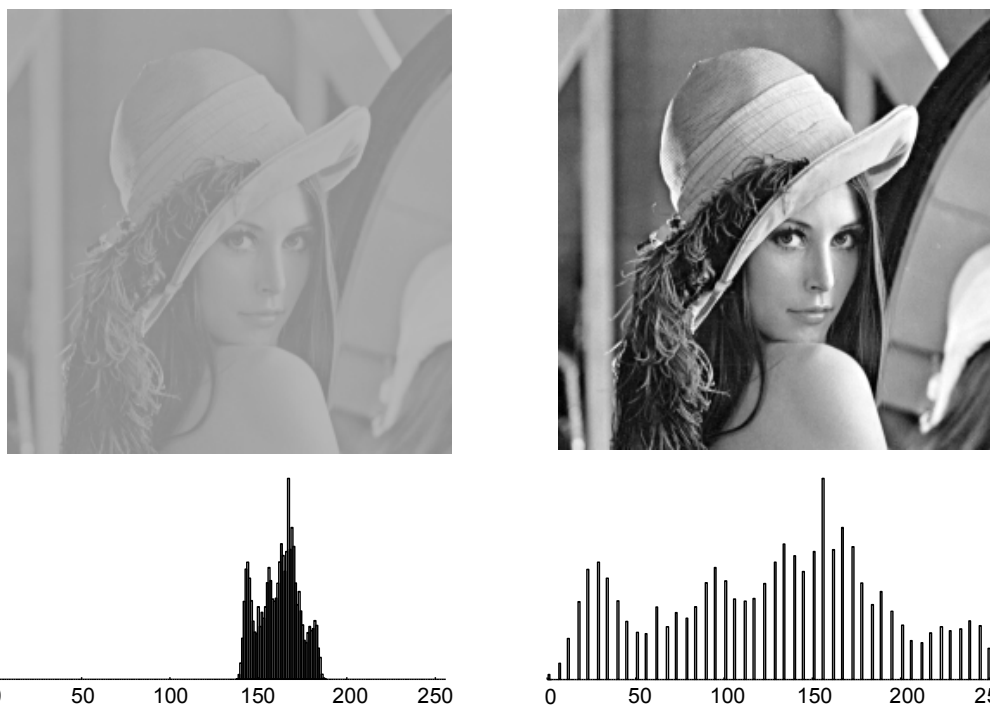

Figure 13.3: Positive influence of histogram equalization on image contrast.

In the GIMP the tool for histogram adjustment is in menu *Colors* → *Levels*. In case of low contrast image in **pic. 13.3** the input levels were set on edges of growing values, but the GIMP can make also automatic equalization with **dialog 13.4**.

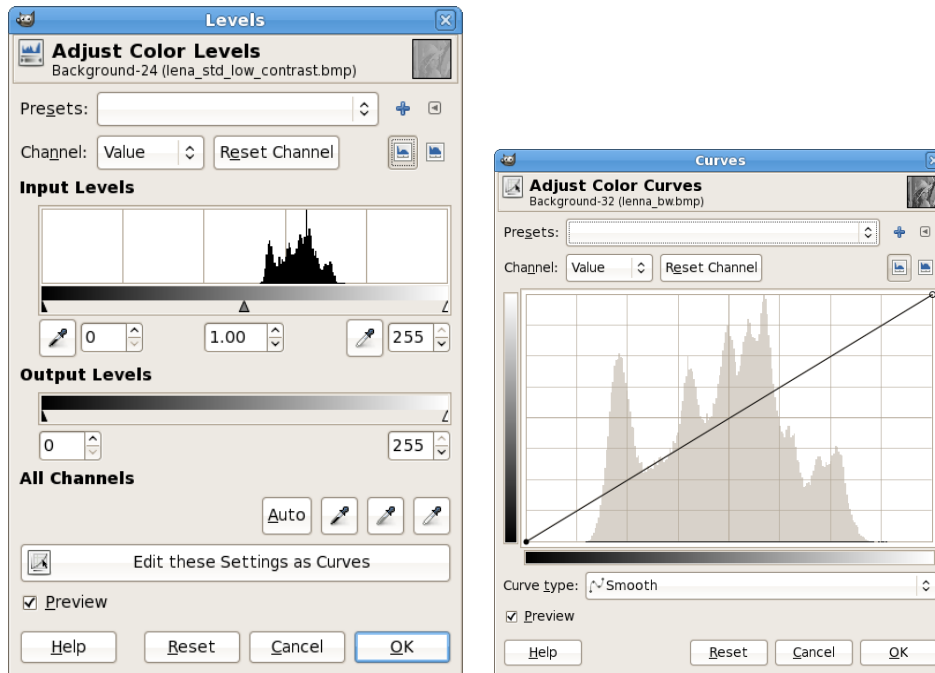

Figure 13.4:

The second important tool is curve adjustment, its the one of most important tools in professional graphics editors. It provides the complex settings of color tone, brightness and contrast. The GIMP tool *Adjust Color Curves* (pic. 13.4) is in menu *Colors* → *Curves*. Its functionality is very similar across image editing software.

The work with curves is quite simple. The tool window has on the x axis displayed input luminance values and on the y axis output values, which are presented as gray-scale. The curve self is the function $y = f(x)$ and it transforms input values to output and by its shaping the user sets the parameters of the transformation.

At the beginning the transformation function is $y = x$ and therefore the output level is equal to input. When you touch the curve by cursor a control point appears on the curve. You can move this point in every direction and if the option *Preview* is switched on, then the results will be shown immediately. It is possible to add more control points for continuous transformation or you can set any curve shape with discontinuous transformation.

What you can do with it? The results of transformations and the used curves is in pic. 13.5. You can spread input values by histogram and improve contrast – 13.5A.

Another use is to darken or lighten the image, but there is many more options how to do this then a simple setting of levels. With the curve you can focus on a range of colors, can edit only midrange portion of color scale and keep black and light pixels, if you hold curve in the middle and move the control point upwards and

if you move the point more to the left or right you can change brightness of darker or lighter tones. In **example 13.5B** are lighter tones made more brighter and the lower end of curve is moved to the right, so darker pixel are more darker and the image is more contrasted. For image darkening move the point downwards, it's in **example 13.5C**, also there is moved the right edge of the curve so lighter pixel are more brighter now.

For changing contrast use the curve in **13.5D**, there are two control points. The curve with “S” shape makes dark tones darker and light tones brighter.

In addition to basic editing the curve can be used for a variety of effects, see **example 13.5**. The shape is little crazy and result image lost real tones. Notice, that there is inversion of dark tones in left part of the curve.

The curve and histogram adjustment is possible to do for image luminance and for each color component too, so it is possible to change color perception of an image.

13.3 Filters

Images can be further improved using various filters. They can serve different purposes, mainly for smoothing and noise reduction, increasing sharpness, edge detection, unsharp masking, etc.

Digital image itself is a discrete two-dimensional (2D) signal, which is characterized by its frequency spectrum, whose components similar to the 1D signal can be determined using the discrete Fourier transform. So it's possible to modify image by using low or high pass filters or highlight certain components to affect the final look.

For specific case, we can return to **chapter 3.2 (page 15)**, there is described how the SSTV transmission is affected by bandwidth. The limited bandwidth caused the distortion of fine grid in resolution test pattern (**pic. 3.3**). Fine grid and sharp gradients in the image represent a high frequency components and limited bandwidth acted as a bandpass filter, which suppressed the higher frequencies. Also, an image noise is represented by high frequency components and the low-pass filter can be used for its reduction. Vice-versa, a high-pass filter is designed to highlight the edges and sharpening.

13.3.1 Convolution matrix

As one of the methods of linear filters is used the higher mathematic procedure – *discrete convolution*. A way the image is processed is given by *convolution kernel*, which is given by matrix, typically with dimensions 3×3 or 5×5 , but also others.

The kernel moves pixel by pixel along lines and columns of the source image and computes pixel values, see **fig. 13.6**. It moves from first pixel on the position 0,0,

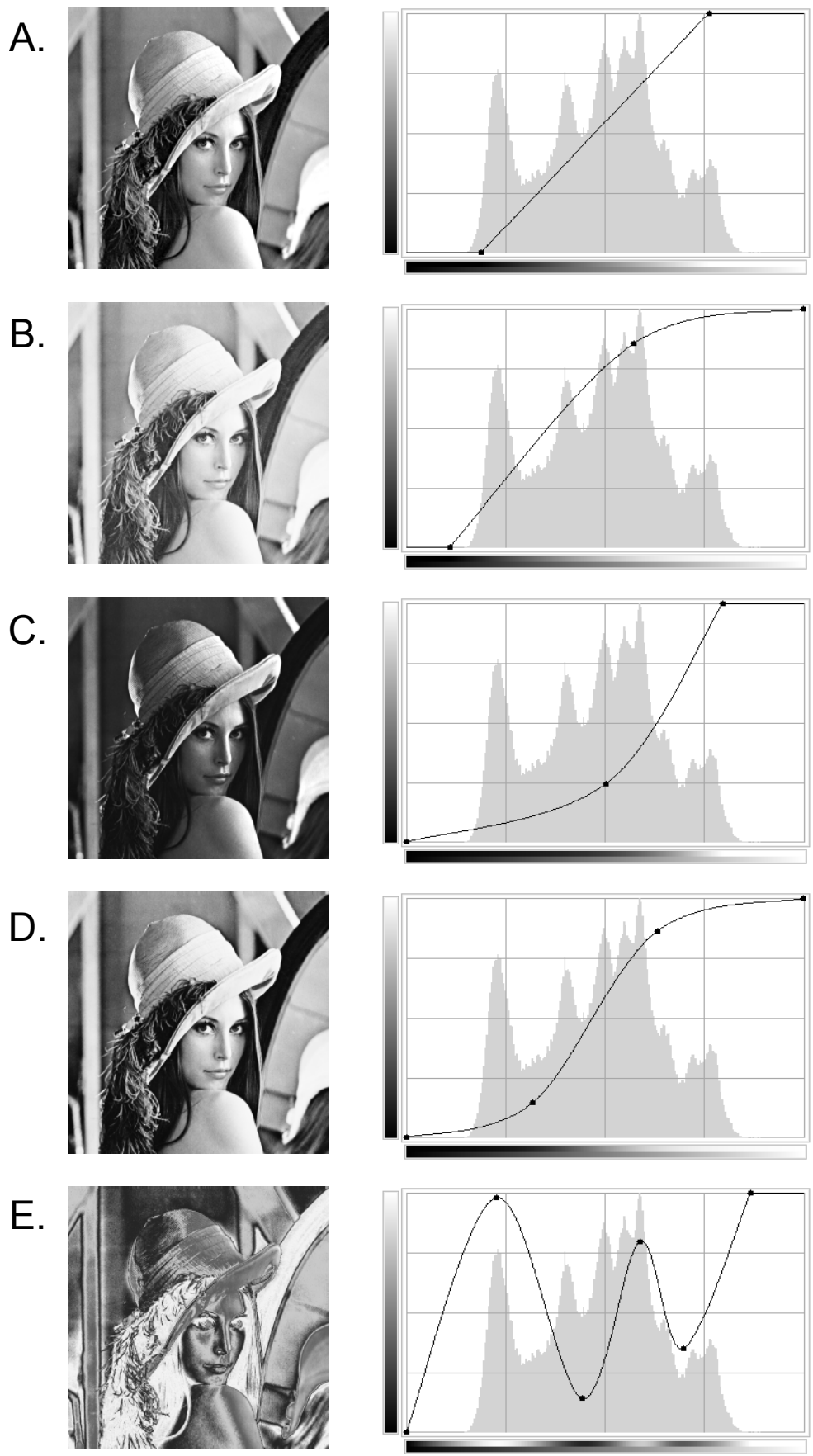

Figure 13.5:

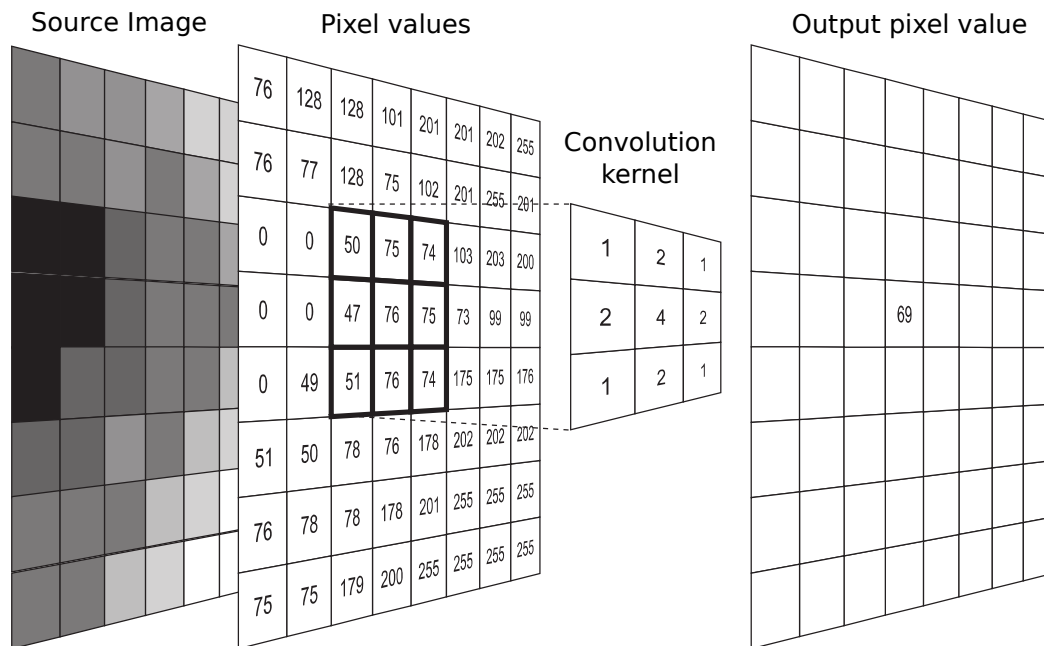

Figure 13.6: Computation of discrete convolution.

then 0,1, etc. For each pixel is from neighborhood pixels (their numerical luminance values) multiplied by kernel values, added together and resulting value is stored in target image on same position as source. Then the matrix moves to next pixel and computation is repeated.

The target image changes in way defined by values of convolution kernel, e.g. matrix \mathbf{H}_2 in **fig. 13.6** use pixel and its neighborhood of 3×3 size and computes weighted mean from these nine pixel with kernel:

$$\mathbf{H}_2 = \frac{1}{16} \begin{pmatrix} 1 & 2 & 1 \\ 2 & 4 & 2 \\ 1 & 2 & 1 \end{pmatrix}, \quad \frac{1}{16} (1 \cdot 50 + 2 \cdot 75 + 1 \cdot 74 + 2 \cdot 47 + 4 \cdot 76 + 2 \cdot 75 + 1 \cdot 51 + 2 \cdot 76 + 1 \cdot 74) = 69$$

The result is an image smoothing and noise reduction. Other matrices are used to increase sharpness, edge detection or to create a relief.

In the GIMP the filter is in menu *Filters* \rightarrow *Generic* \rightarrow *Convolution Matrix*. The important parameters are also *divisor*, which adjusts the values in the matrix and *offse* is used to adjust the colors. See **fig. 13.7**, how to set matrix values and parameters. Furthermore you can choose the color channels and behaviour of calculation on border pixels, it is also possible to determine the divisor and offset automatically.

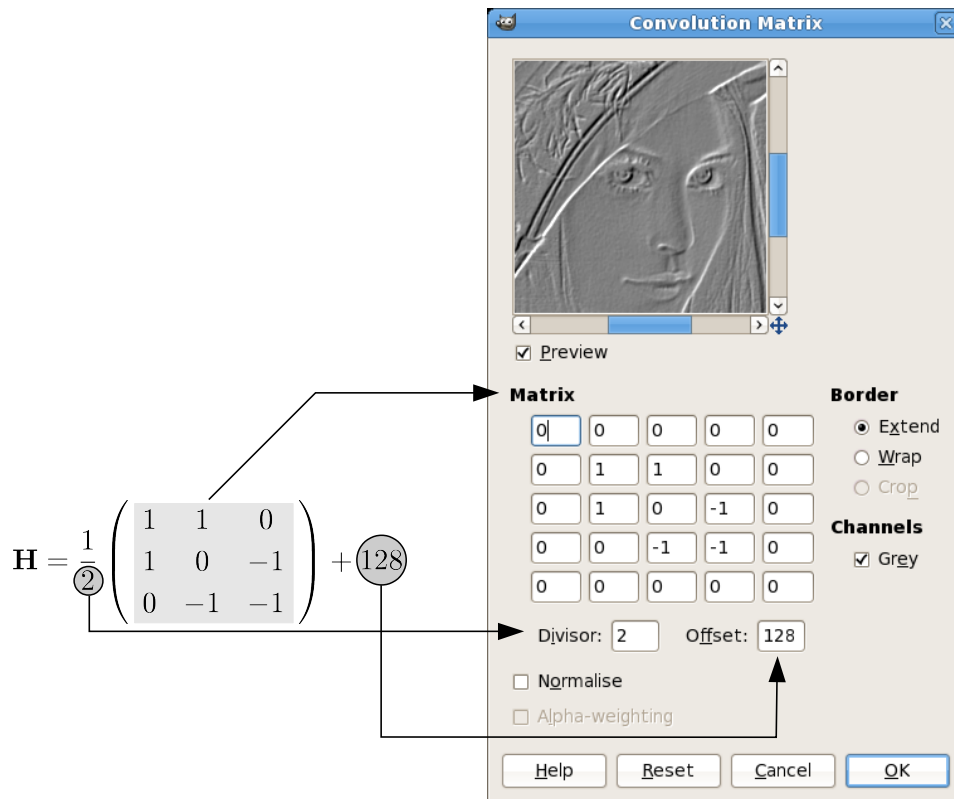

Figure 13.7: Convolution matrix parameters in GIMP.

13.3.2 Noise reduction

Thanks to noise reduction it is possible to improve partially received SSTV or WE-FAX images by smoothing. It can be done several ways. Since SSTV transmission takes a relatively long time the noise levels are often uneven, affected by random interference and transmission conditions, so you can by tool *Selection* mark affected areas, where apply the filter.

13.3.2.1 Spatial average filtering

The simplest way to reduce noise is *average filter* with convolution kernel \mathbf{H}_1 .

$$\mathbf{H}_1 = \frac{1}{9} \begin{pmatrix} 1 & 1 & 1 \\ 1 & 1 & 1 \\ 1 & 1 & 1 \end{pmatrix}$$

The next useful matrices for averaging are \mathbf{H}_2 and \mathbf{H}_3 , they aren't using neighbor pixel with same weight, but near pixels have greater coefficients than farther. The values of the coefficients are based on binomial series.

$$\mathbf{H}_2 = \frac{1}{16} \begin{pmatrix} 1 & 2 & 1 \\ 2 & 4 & 2 \\ 1 & 2 & 1 \end{pmatrix} \quad \mathbf{H}_3 = \frac{1}{256} \begin{pmatrix} 1 & 4 & 6 & 4 & 1 \\ 4 & 16 & 24 & 16 & 4 \\ 6 & 24 & 36 & 24 & 6 \\ 4 & 16 & 24 & 16 & 4 \\ 1 & 4 & 6 & 4 & 1 \end{pmatrix}$$

The disadvantage of averaging filters is that smoothing distorts sharp color gradients and due to it thin lines and other details are distorted.



Received image

Averaging \mathbf{H}_1 Binom. filter $3 \times 3\mathbf{H}_2$ Binom. filter $5 \times 5\mathbf{H}_3$ **Figure 13.8:**

Next filters for noise reduction in GIMP are in menu *Filters* \rightarrow *Blur* \rightarrow E.g. *Gaussian blur* is useful for SSTV noise reduction, the user can set a radius of a blur. For image preparation can be used *Selective Gaussian Blur*, it can filter continuous areas and edges leaves unaffected, but for received images is not suitable.

13.3.2.2 Median filter

The term *median* is the middle value in list of numbers, here luminance values. The image filter works with pixel neighborhood, e.g. with 3×3 size, then sort their values and takes the median, i.e. middle value of the sequence:

			Pixels: 21, 22, 20, 21, 19, 231, 19, 21, 20
21	22	20	Sorted: 19, 19, 20, 20, <u>21</u> , 21, 21, 22, 231
21	19	231	Average \doteq 43; Median = 21
19	21	20	

Table 13.1: none

We see that if we use the averaging, then significantly skewed value 231, which can be caused by noise, greatly affects the result. In contrast, the median is not influenced by extreme deviations. The disadvantage of median filtering is that it sometimes distorts the thin lines and sharp gradient in the image.



Figure 13.9: The results of noise reduction with median filter.

In GIMP the median filter is in *Filters* → *Enhance* → *Despeckle*. There are several options for filter settings. The radius from 1 for 3×3 neighborhood to 20 for 41×41 and the black level (−1–255) and white (0–256). The pixels darker or brighter than these two levels will be removed, filter passes every level for the extreme values −1 and 256. Moreover, it is still possible to select *adaptive* median, when GIMP tries to determine optimal radius for given image location automatically (the user parameters are ignored).

13.3.3 Sharpening

Often happens that images from cameras or scanners have reduced sharp edges. In this case you can try to use sharpening filters, for edges highlighting. There are two convolution kernels for sharpening \mathbf{H}_4 and \mathbf{H}_5 with an even stronger effect.

$$\mathbf{H}_4 = \begin{pmatrix} 0 & -1 & 0 \\ -1 & 5 & -1 \\ 0 & -1 & 0 \end{pmatrix} \quad \mathbf{H}_5 = \begin{pmatrix} -1 & -1 & -1 \\ -1 & 9 & -1 \\ -1 & -1 & -1 \end{pmatrix}$$

In the GIMP the sharpening filters are in the menu *Filters* → *Enhance* →.... The first one is *Sharpen*, and it has similar results as kernels above and it is possible to set sharpening level and from preview select the best results.

The disadvantage of these filters is that, it also highlights the image noise and some other unwanted details. It can be seen in **fig. 13.10** when the filter \mathbf{H}_5 is used, so there appears teeth on vertical edges caused by camera interlacing. In this case it's possible to use filter called *unsharp mask*. The unsharp mask procedure in first step apply Gaussian blur on image copy and then check the difference between blurred and original image. When the difference is greater then a user-defined threshold, then both images are subtracted and the result is added to original image. The threshold limits the sharpness of output image, so small details of certain size is not sharpened. Thanks to this the sharpening does not apply to noise and graininess. The digital unsharp mask is great filter for enhancing sharpness. Some results are influenced by these three parameters:

- ▷ *Amount* indicates how much will increase the contrast of edges, by the edge lightens or darkens, this setting will affect most the degree of sharpening.
- ▷ *Radius* sets how much pixels around edges will be used. For smaller radius the filter affect also smaller details, but for greater it may produce a bright rim around edges.
- ▷ *Threshold* controls the minimum brightness change that will be sharpened. Thanks to threshold it is possible to enhance only stronger edges and finer leave unchanged.



Original image
from CCD camera



Sharpening H_4



Sharpening H_5



radius: 2.5; amount:
1.5; threshold: 0

Figure 13.10: Results of image sharpening.

No wonder, that unsharp mask is considered as king in improving the image. The only drawback is that if you blow over it, then around edges occurs distinctive bright rim and the image looks unnaturally.

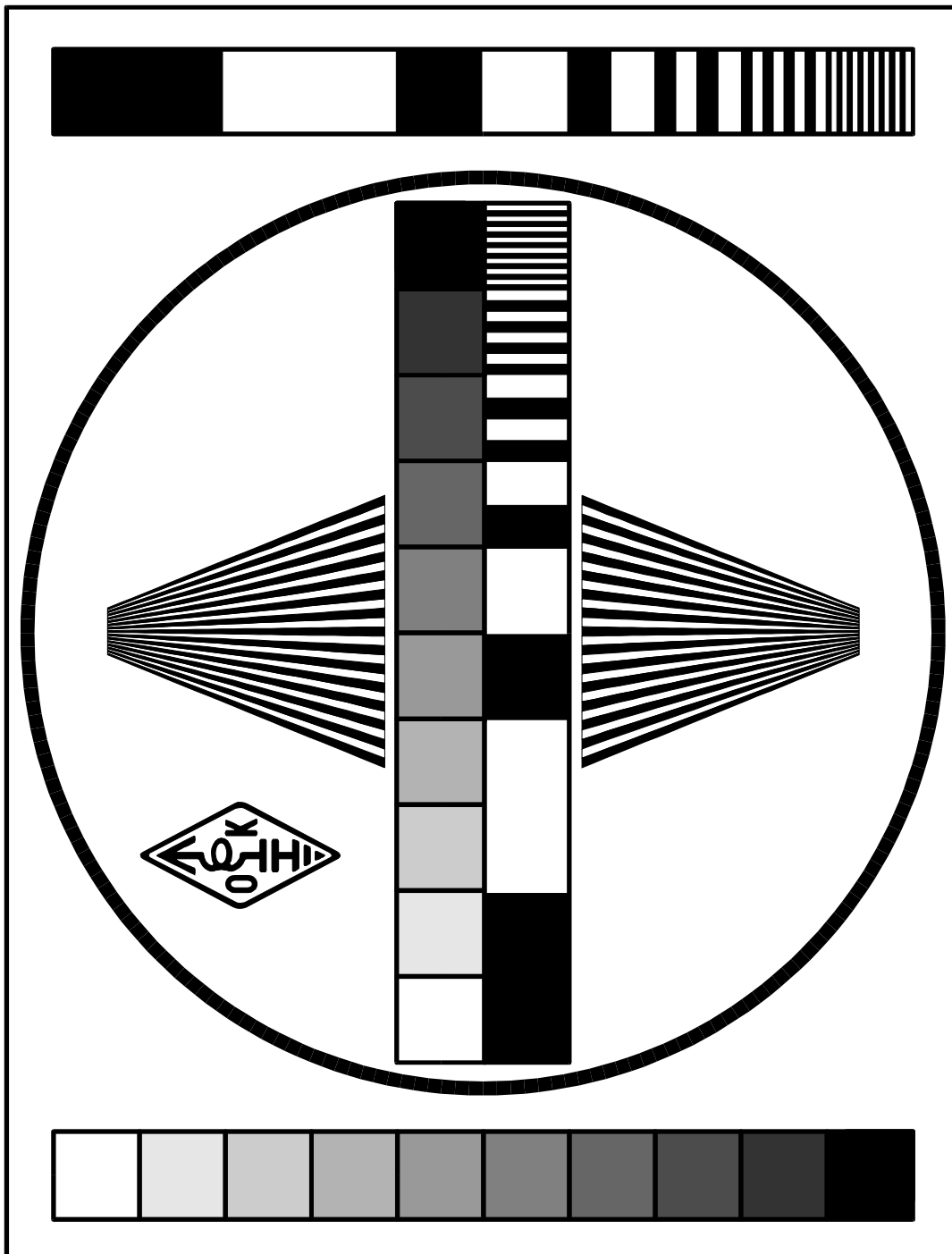

Figure 13.11: none

References

- [1] Adámek, J.: *Kódování*. SNTL 1989.
- [2] Abrams, Clay K6AEP; Taggart, Ralph WB8DQT: *Color Computer SSTV*. 73, Nov., Dec. 1984.
- [3] American Radio Relay League: *The ARRL Handbook for Radio Communications*. ARRL 2011.
- [4] Barber, James L. N7CXI: *Proposal for SSTV Mode Specifications*. Dayton SSTV forum, 2000.
- [5] Bodson, Dennis W4PWF; Karty, Steven N5SK: *FAX480 and SSTV Interfaces and Software*. QST, Jul. 1998.
- [6] Bruchanov, Martin OK2MNM: *Ještě k SSTV*. AMA magazín, červenec 1997.
- [7] Cameroni, Giuseppe I2CAB; Morellato, Giancarla I2AED: *Get on SSTV – with the C-64*. Ham radio, Oct. 1986.
- [8] Churchfield, Terry K3HKR: *Amiga AVT System*. 73 Amateur Radio, Jul. 1989.
- [9] Cordesses, Lionel; Cordesses, Roland F2DC: *Some Thoughts on “Real-Time” SSTV Processing*. QEX, No. 218, May, June 2003.
- [10] Cook, S. A. G., G5XB: *Hellscheiber, What is it and how it works*. Radio Communication, Apr. 1981.
- [11] Dewitt, H. William, W2DD: *The Robot Research Inc. Model 1200C Color Slow Scan Converter*. CQ, Jun. 1988.
- [12] ETSI Standard: *Digital Radio Mondiale (DRM); System Specification*. 2005 [ETSI ES 201 980 V2.2.1].
- [13] Dobeš, Josef; Žalud, Václav: *Moderní radiotechnika*. BEN technická literatura 2006.
- [14] Evers, Hans PA0CX: *The Hellscheiber Rediscovery*. Ham Radio, Dec. 1979.
- [15] Fanti, Franco: *Facsimile*. CQ-TV, vol. 88, 1974.
- [16] Fingerhut, K., Půža, V.: *Amatérská televize*. Svazarm 1983.
- [17] Frejlach, Karel: *Příjem signálu SSTV mikropočítačem ZX Spectrum*. Radioamatérský zpravodaj, vol. 4, 9, 1989.
- [18] Frejlach, Karel: *Digitální radioamatérský provoz*. Autor vlastním nákladem 1998.
- [19] Ford, Steve WB8IMY: *TV on 10*. QST, Apr. 2001.
- [20] Furukawa, Bruce T.; Murray, Thomas L.; McGee Kenneth A.: *Video Surveillance of Active Volcanoes Using Slow-Scan Television*. USGS Bulletin, 1992.
- [21] Geier, Michael Jay KB1UM: *The SSTV Explorer*. Radio Fun, vol. 6, 1995a.
- [22] Geier, Michael Jay KB1UM: *Pasokon TV Slow-Scan TV Interface*. 73 Amateur Radio Today, July 1995b.
- [23] Glanc, Antonín OK1GW: *Amatérská televize*. Amatérské rádio, vol. 6, 7, 8, 1971.
- [24] Glidden, Ramon L. W5NOO: *Getting Started with Slow Scan Television*. QST, Sep. 1997.
- [25] *GNU Image Manipulation Program – User Manual*. .
- [26] Gola, Miroslav ing. OK2UGS: *Přijímač faksimile v pásmu KV (40)*. Praktická elektronika ARadio, vol. 4, 5, 1999.
- [27] Goodman, Dick WA3USG: *SSTV with the Robot 1200C Scan Converter and the Martin Emmerson EPROM Version 4.0*. 73 Amateur Radio Today, Jul. 1991.
- [28] Harlan, Gene WB9MMM: *Slow-Scan TV with the Sound Blaster*. QEX, May 1993.
- [29] Hioki, Takashi JF1GUQ: *Pasokon TV*. Mobile Ham Amateur Radio Magazine, Feb. 1993.

- [30] Hubeňák, Jiří RNDr.: *Zařízení pro příjem faksimile počítačem PC AT*. Amatérské Rádio, vol. 6, 1994.
- [31] Jordan, Karel Ing.: *Radioamatérské družice*. Ústřední rada radioklubu Svazarmu 1983.
- [32] Karmasin, Karel OK2FD: *SSTV a PC*. AMA magazín, duben 1997.
- [33] Langner, John WB2OSZ: *SSTV – The AVT System Secrets Revealed*. CQ-TV, vol. 149, 1990.
- [34] Langner, John WB2OSZ: *Slow-Scan Television – It isn't expensive anymore*. QST, Jan. 1993.
- [35] Langner, John WB2OSZ: *Color SSTV for the Atari ST*. 73 Amateur Radio, Dec., Jan. 1989, 1990.
- [36] Langner, John WB2OSZ: *Slow-Scan TV Questions and Answers*. Radio Fun, Feb. 1995.
- [37] Montalbano, John KA2PYJ: *The ViewPort VGA Color SSTV System*. 73, Aug. 1992.
- [38] Nozdrovický L.: *Základy televízie*. Slovenské vydavateľstvo technickej literatúry 1962.
- [39] Null Linda, Lobur Julia: *The Essentials of Computer Organization and Architecture*. Jones and Bartlett Publishers 2003.
- [40] : *Nové směry v SSTV*. Amatérské rádio, vol. 7, 8, 1986.
- [41] Pagel, Paul N1FB: *Radioware SSTV Explorer*. QST, Apr. 1994.
- [42] Pitt, Doug: *Basic NBTV Techniques*. 1998.
- [43] Prinz, Richard OE1RIB: *Kamera-Shield auf Arduino-Basis für ein SSTV-Sendemodul*. Funkamateureur, vol. 10, 2012.
- [44] Prosis, Jeff: *Bitmapové soubory – pohled dovnitř*. PC Magazine, únor 1997.
- [45] Ramon, Carine ON7LX: *HF Managers Handbook*. IARU 2003.
- [46] Rensen, Marius: *HF FAX Station List*. , 2002.
- [47] Schick, Martin K. KA4IWG: *Color SSTV and the Atari Computer*. QST, Aug. 1985.
- [48] Seger, Jiří: *Jak se lidé dorozumívali*. Albatros 1987.
- [49] Taggart, Dr. Ralph E. WB8DQT: *A New Standard for Amateur Radio Facsimile*. QST, Feb. 1993.
- [50] Taggart, Dr. Ralph E. WB8DQT: *Digital Slow-Scan Television*. QST, Feb. 2004.
- [51] Taggart, Dr. Ralph E. WB8DQT: *The ARRL Image Communications Handbook*. ARRL 2002.
- [52] Taggart, Dr. Ralph E. WB8DQT: *The Romscanner*. QST, Mar. 1986.
- [53] U.S. Department Of Commerce: *Worldwide Marine Radiofacsimile Broadcast Schedules*. NOAA 2010.
- [54] Vester, Ben K3BC: *An Inexpensive SSTV System*. QST, Jan. 1994a.
- [55] Vester, Ben K3BC: *An Inexpensive SSTV System continues to Grow*. QST, Dec. 1994b.
- [56] Vít, V.: *Televizní technika – barevné přenosové soustavy*. BEN technická literatura 1997.
- [57] Vlček, K.: *Kompresa a kódová zabezpečení v multimediálních komunikacích*. BEN technická literatura 2004.
- [58] *Vyhláška FMS č. 390/1992 Sb. o povolování amatérských vysílacích stanic*. Ministerstvo spojů 1992.
- [59] Wolfgang, Larry WR1B: *TASCO Electronics TSC-70U Slow-Scan TV System*. QST, Apr. 1997.
- [61] Žára Jiří, Bedřich Beneš, Felkel Petr: *Moderní počítačová grafika*. Computer Press 1998.