

# ALC Module

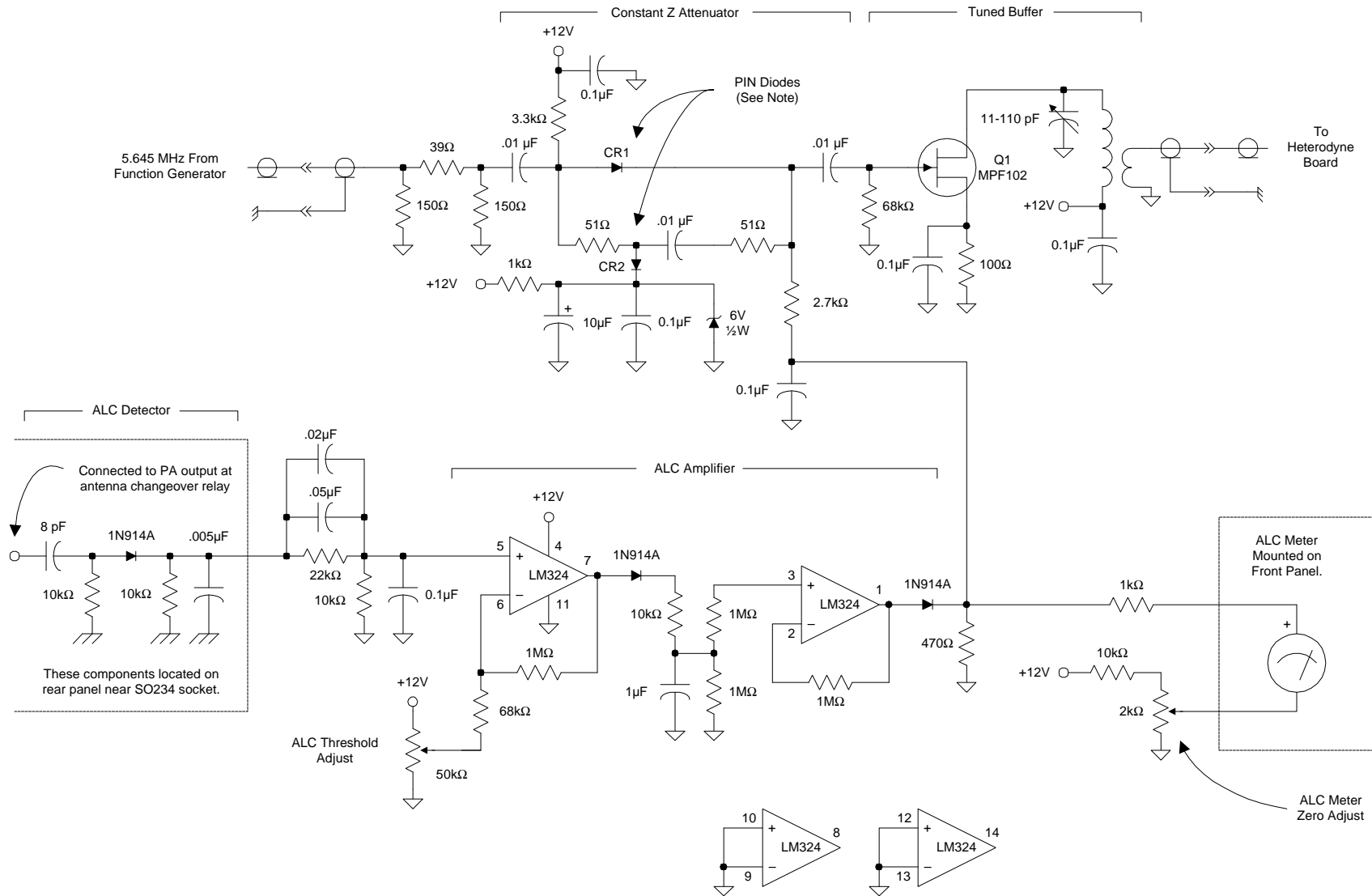

K9GDT 40m Multimode Transmitter

Notes:  
CR1, CR2 - Unidentified "Hamfest" PIN Diode (MFR Unknown)

by George!  
9/11/95

# Chassis Wiring

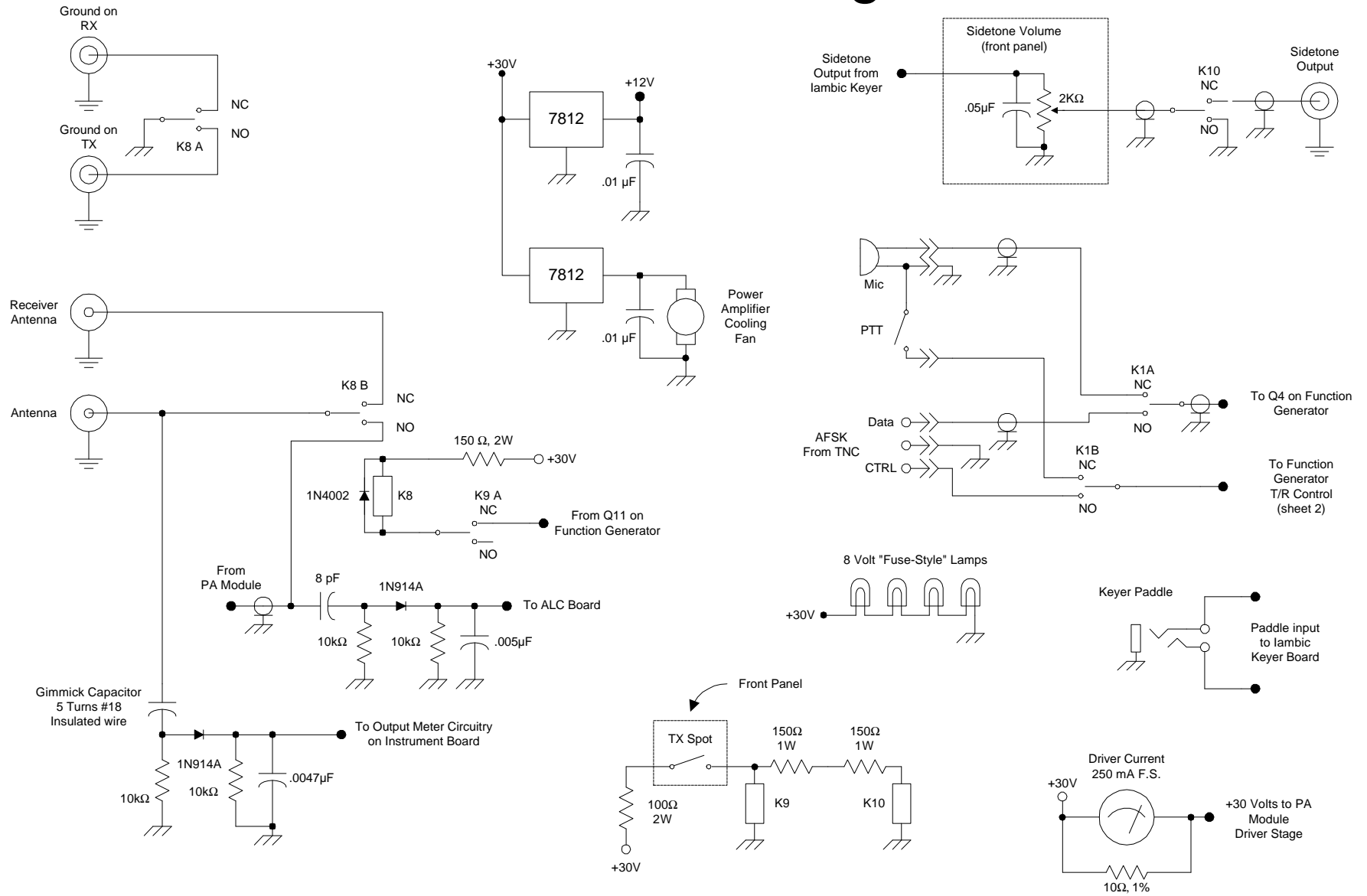

# Function Generator

Sheet 1 of 2  
Signal Generation

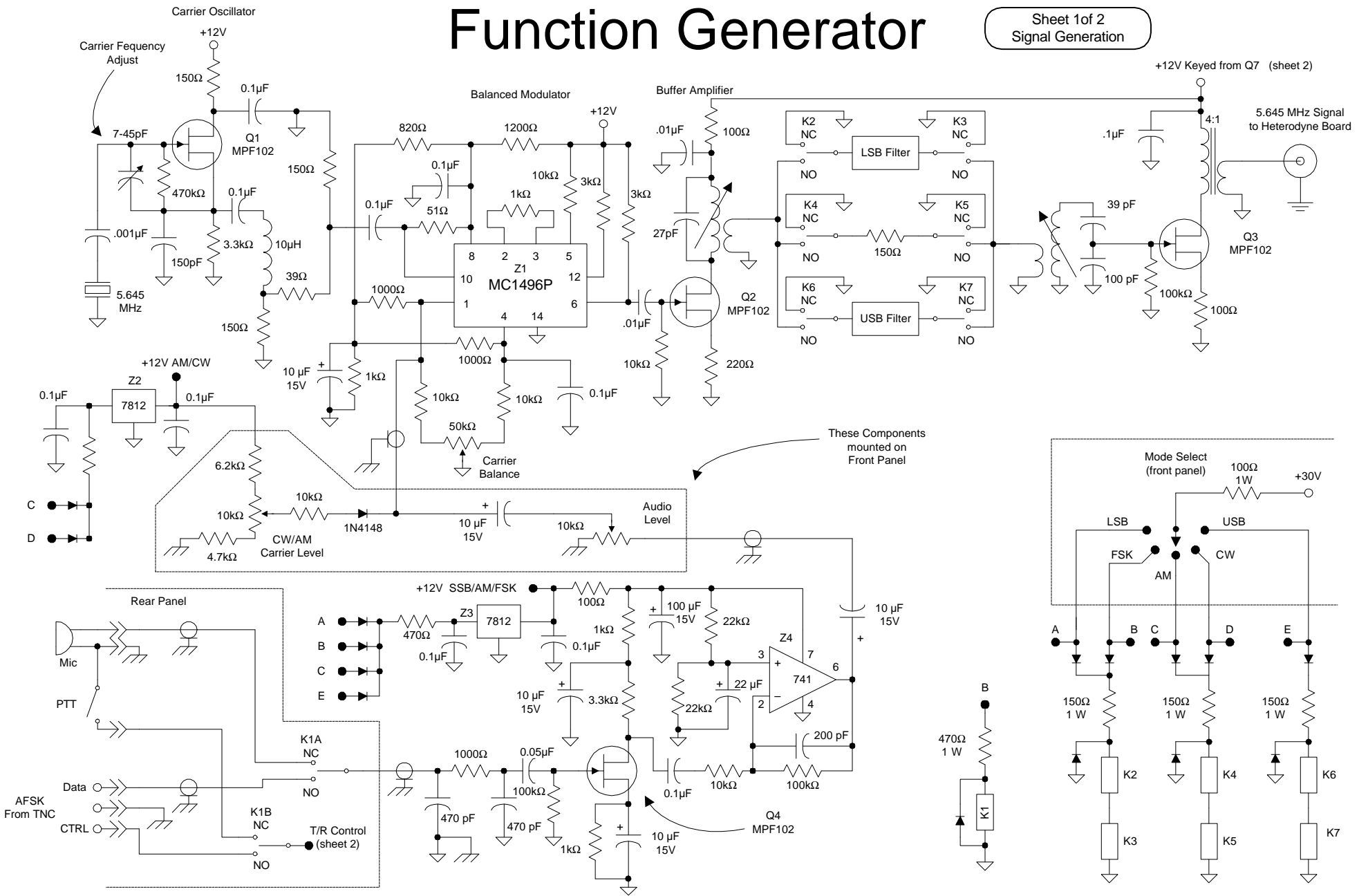

## K9GDT 40m Multimode Transmitter

NOTE: Unless otherwise indicated, all resistors are 1/2 Watt.  
All diodes are 1N4002  
K1 - ?  
K2 - K7 Radio Shack 275-241

by George!

8/20/95

# Function Generator

Sheet 2 of 2  
Control Circuitry

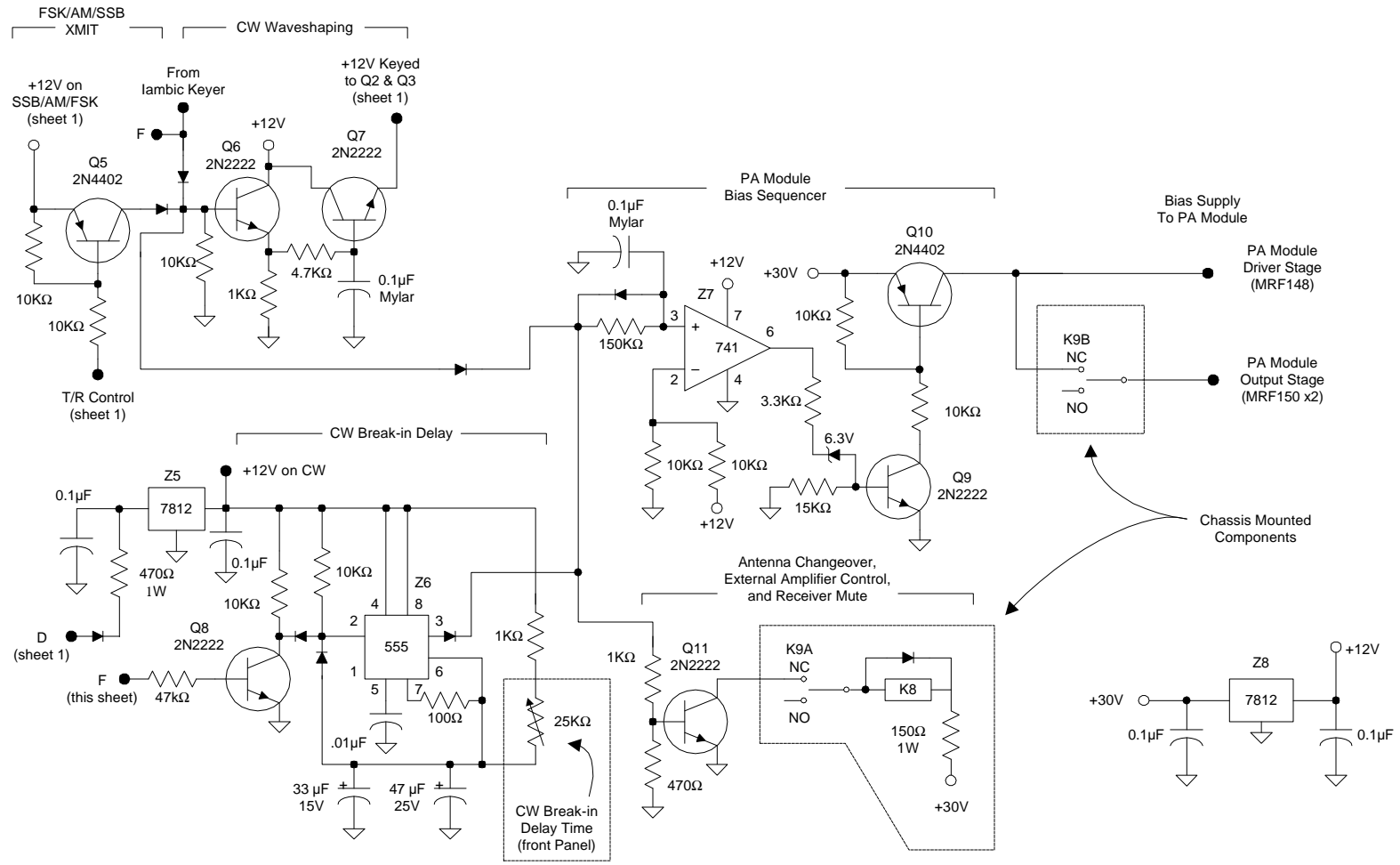

# Heterodyne Board

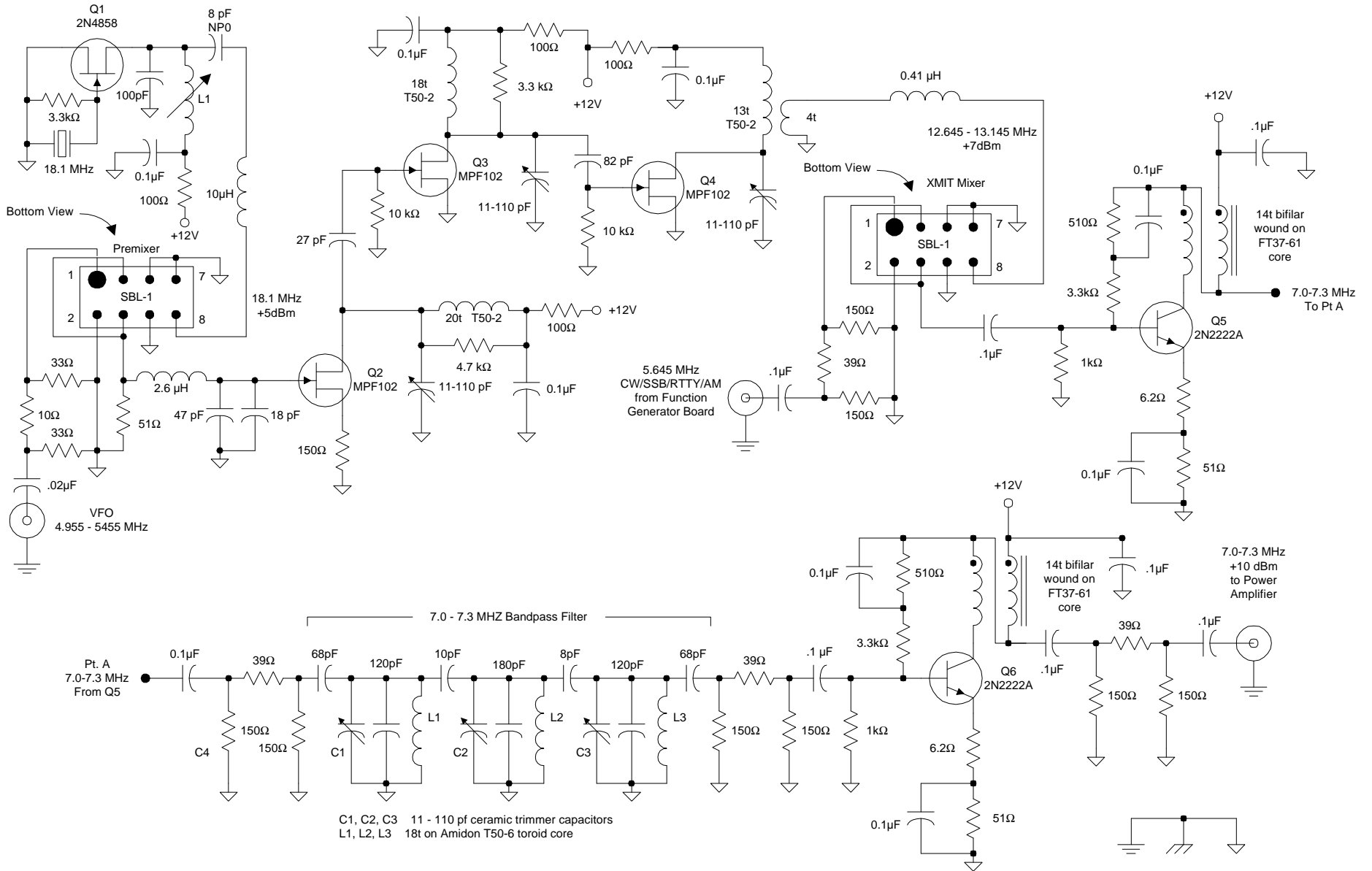

K9GDT 40m Multimode Transmitter

8/3/95

by George!

# Iambic Keyer

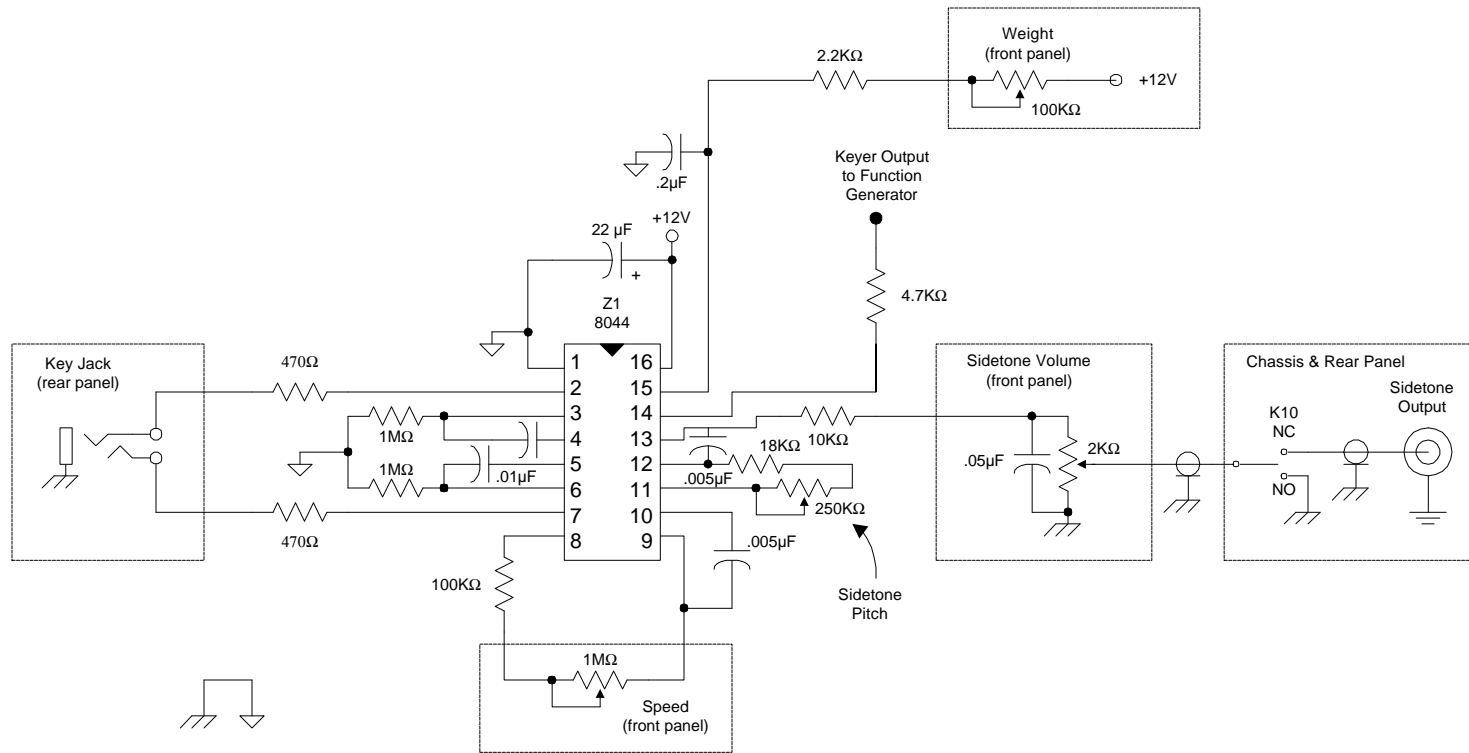



# Power Amplifier Module

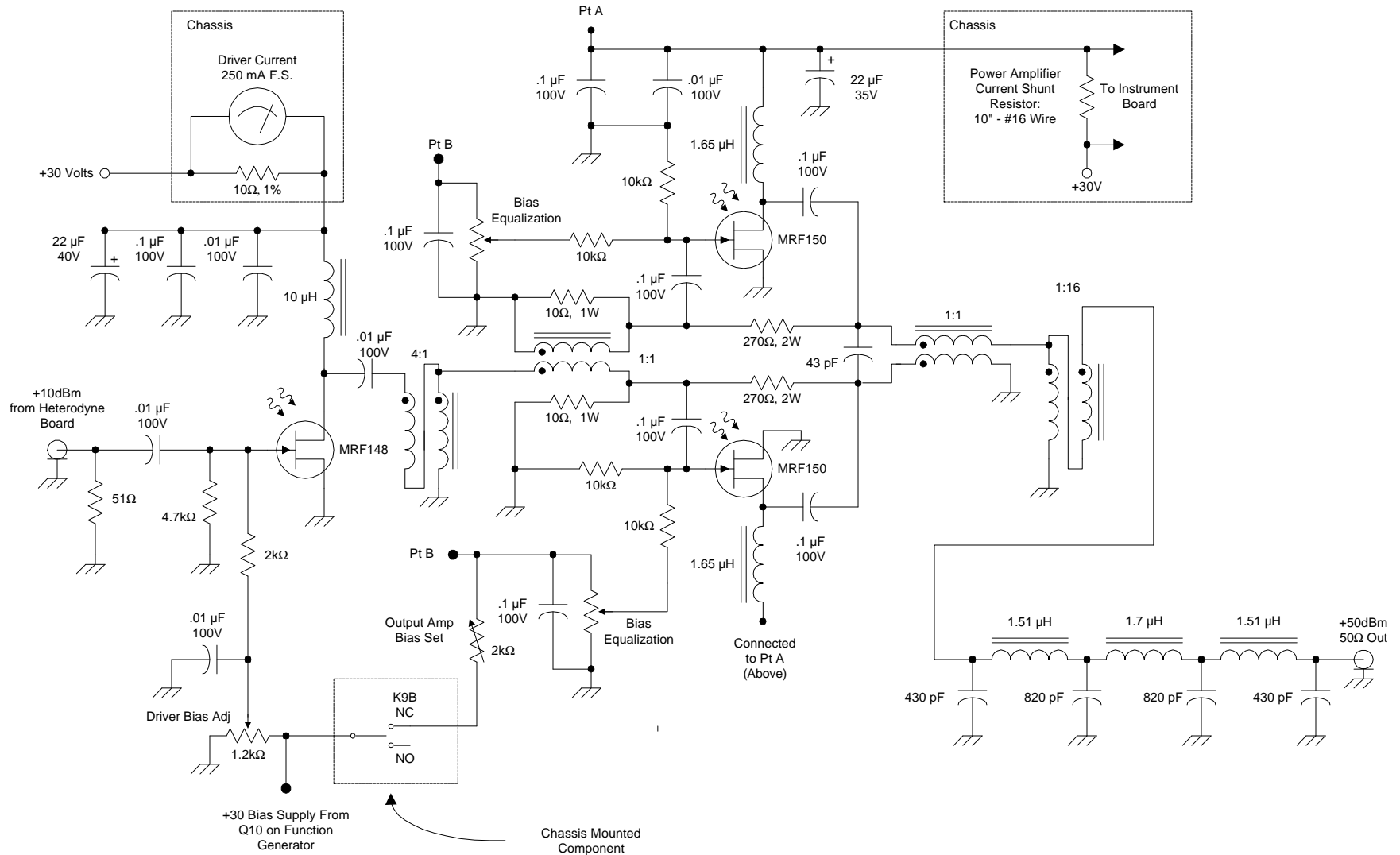

K9GDT 40m Multimode Transmitter

by George!  
7/10/95



# Power Supply

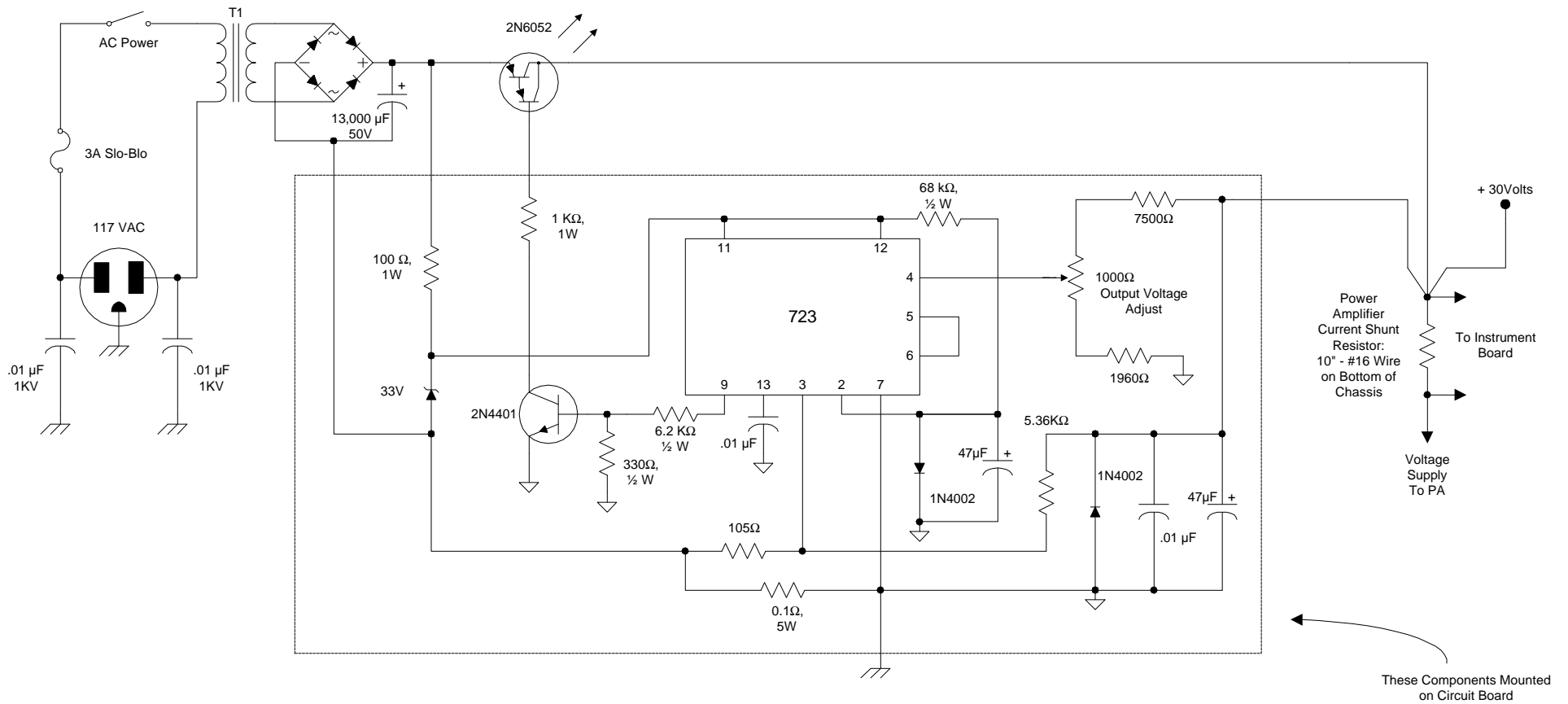

K9GDT 40m Multimode Transmitter

by George!  
7/26/95

# Tuning Assembly

4.955 - 5.455 MHz to Heterodyne Board

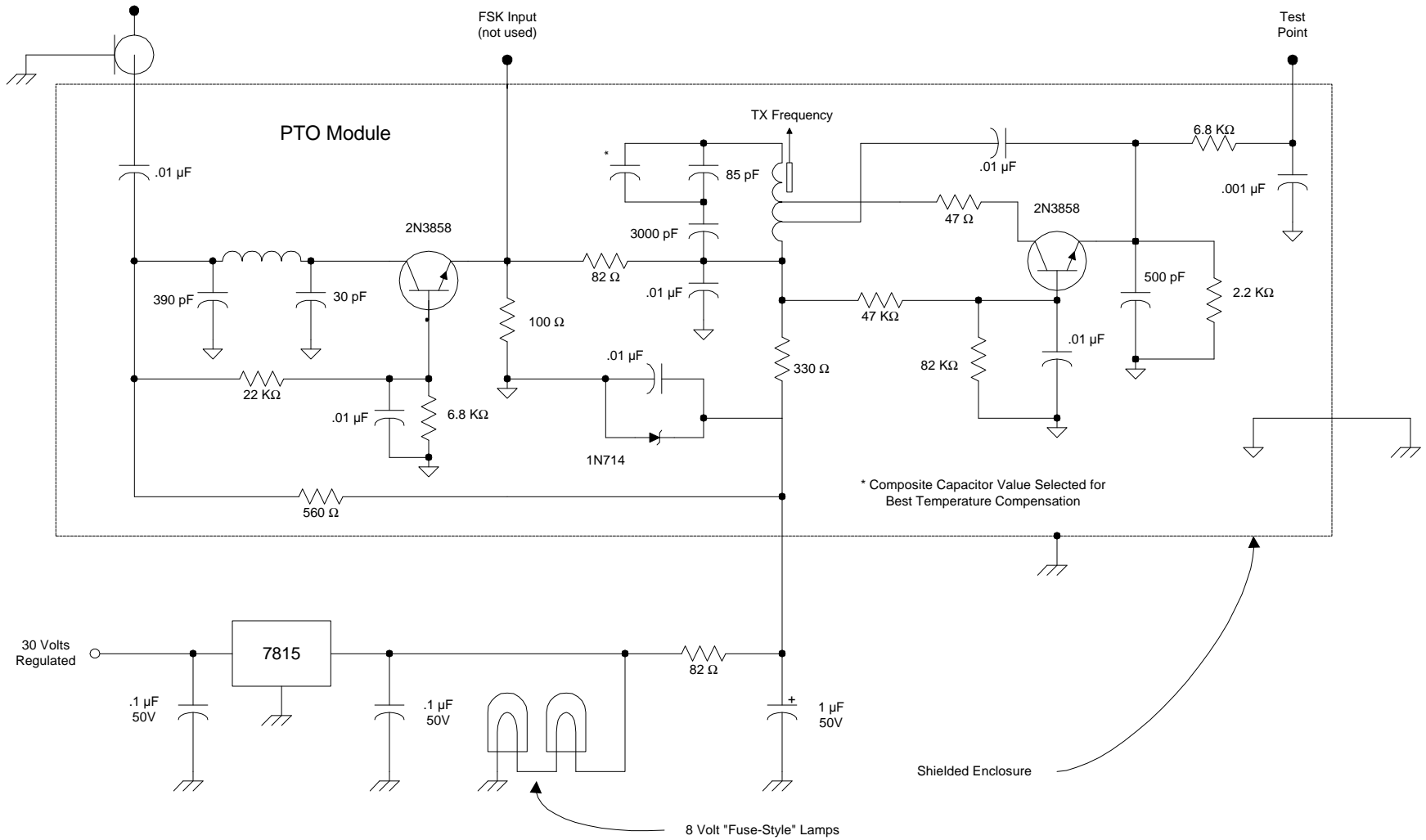

K9GDT 40m Multimode Transmitter

by George!  
7/21/95