



# The HPND-4050 Beam Lead Mesa PIN in Shunt Applications

## INTRODUCTION

The beam lead PIN diode, while satisfying requirements for low capacitance and planar circuit attachment, is generally fabricated as a planar PIN diode in order to provide mechanical support to the fragile beam leads. However, planar PIN diodes are characterized by relatively long minority carrier lifetimes and reverse recovery times as a result of unequal carrier path lengths in the I region. The HPND-4050 beam lead mesa PIN shown in Figure 1 provides a thin, uniform I region which contributes not only to improved switching speed but also lower series resistance. In the mesa structure the minority carriers are confined, resulting in short, uniform carrier paths and a minority carrier lifetime of 15 nanoseconds

and reverse recovery time of 2 nanoseconds. This improved switching speed makes the HPND-4050 suitable for fast-acting switches, attenuators, modulators, and phase shifters. The low series resistance achievable at low current (1.3 ohms at 10 mA) makes it ideal for applications in the shunt configuration.

Glass backfilling reduces parasitic capacitance and provides a strong support pad for the fragile beam lead, resulting in a high lead pull strength of 4 grams. A nitride passivation layer provides immunity from contaminants which would otherwise lead to reverse leakage current drift. A deposited glass layer affords protection against scratches during handling and assembly. The net result is a beam lead diode of rugged construction capable of applications up through the Ku-band. Its low RC product of .16 ps in conjunction with its other unique characteristics make it suitable for a shunt switching element in microstrip and stripline circuits. Hence, this application note is devoted primarily to the discussion of the performance of the HPND-4050 in the shunt configuration. Although the performance discussion is concentrated on microwave switching capabilities, this diode can also be used in other applications, such as attenuation, modulation, and phase shifting, and the data and techniques provided can be applied to these areas accordingly.

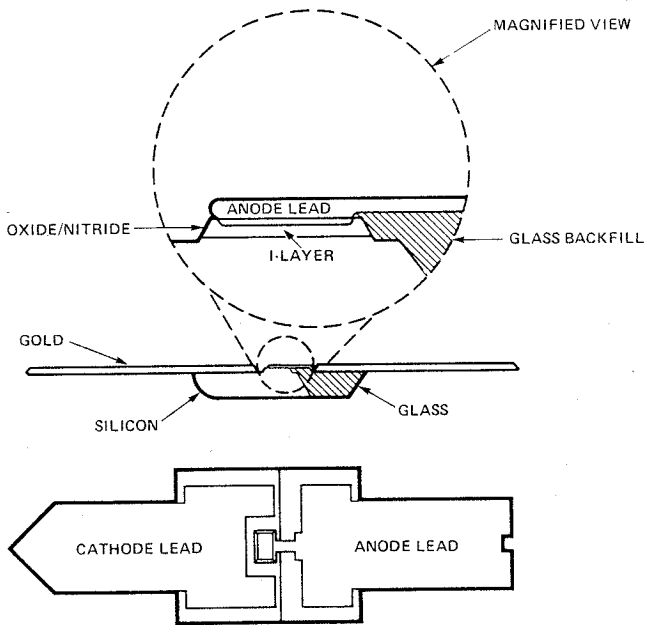

## SHUNT SWITCH APPLICATION

As described above, the characteristics of the HPND-4050 make it well suited for switching applications in the shunt configuration.

A simplified shunt PIN reflective switch is shown in Figure 2. For a first order analysis, if packaging parasitics are negligible, the forward biased PIN can be approximated by a resistor and the reverse biased PIN by a capacitor. Accordingly, when the switch is ON (PIN reverse biased), the insertion loss is primarily determined by the junction capacitance of the PIN and the frequency of the RF signal. When the switch is OFF (PIN forward biased), the isolation is principally dependent on the PIN resistance. The approximate insertion loss and isolation that can be expected from a PIN shunt switch in a 50 ohm system can thus be readily determined from the curves or equations in

**Figure 1. Beam Lead Mesa PIN Structure.**

A thin uniform I region lowers series resistance and improves switching speed. Glass backfilling reduces parasitic capacitance and provides a strong contact pad for the fragile beam lead.

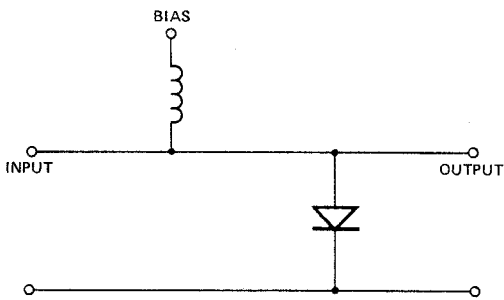

(A) SHUNT PIN REFLECTIVE SWITCH

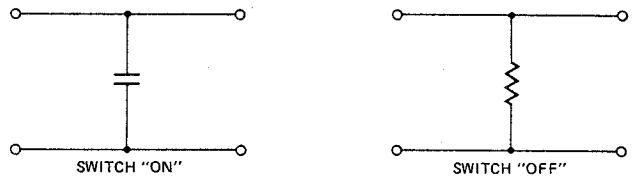

(B) APPROXIMATE REPRESENTATION OF SWITCHING STATE

Figure 2. Simplified Schematic of Shunt PIN Reflective Switch and Model for "ON" and "OFF" states.

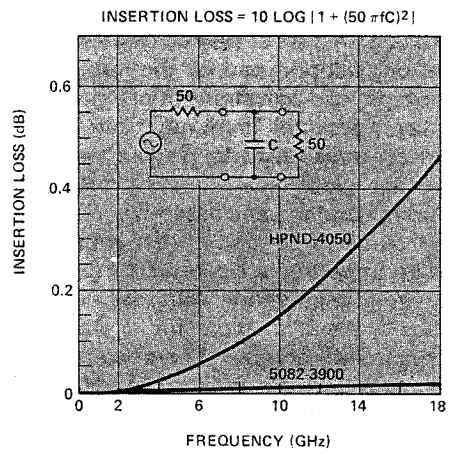

Figure 3. Approximate Insertion Loss of Shunt PIN Switch in 50 Ohm System.

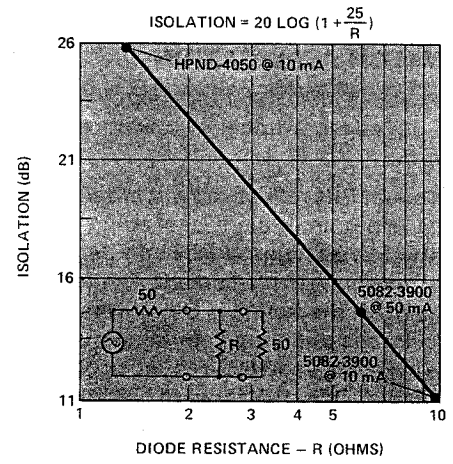

Figure 4. Approximate Isolation of Shunt PIN Switch in 50 Ohm System.

Figures 3 and 4. For the shunt switch the lower the capacitance the lower is the insertion loss at a given frequency. On the other hand, lower resistance results in higher isolation. Hence, the desirability of the low RC product in the HPND-4050 is apparent. It can be seen that at normal bias levels, the HPND-4050 (compared to the planar PIN 5082-3900) is capable of achieving significantly higher isolation at the expense of a little additional insertion loss at higher frequencies.

**SWITCHING PERFORMANCE**

The above analysis provides a quick first order approximation of shunt PIN switching performance, but neglects the effects of package and circuit parasitics. In actual switching performance, the effects of these parasitics may not be negligible, particularly at higher frequencies. In this case, the attenuation is given by

$$\alpha = 10 \text{ log } \left[ \frac{\left( \frac{R_s Z_o}{R_s^2 + X_s^2} + 2 \right)^2 + \left( \frac{X_s Z_o}{R_s^2 + X_s^2} \right)^2}{4} \right]$$

where  $R_s$  and  $X_s$  are, respectively, the series equivalent resistance and reactance of the combined impedance of the packaged diode and the circuit parasitics.

The actual performance of the HPND-4050 as a shunt switch is illustrated in Figures 5 and 6. The points denoted by  $\Delta$  are results of a computer analysis yielding the

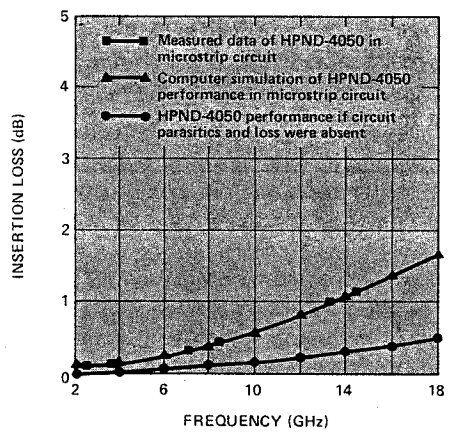

Figure 5. Insertion Loss of HPND-4050 as Shunt Switch.

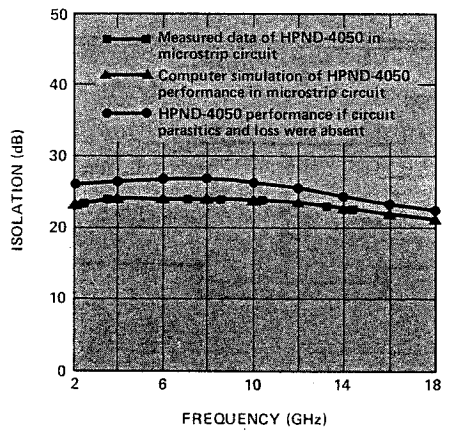
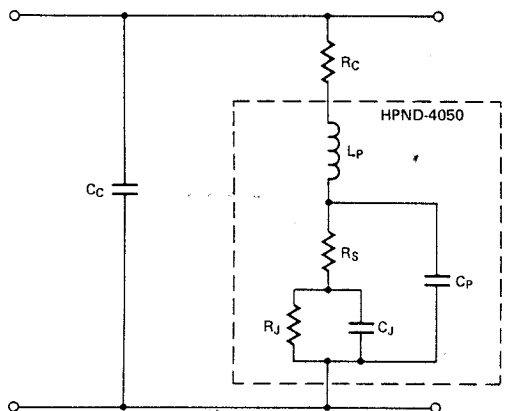

Figure 6. Isolation of HPND-4050 as Shunt Switch.

equivalent circuit shown in Figure 7. It can be observed that isolation actually increases with frequency up to X-band due to shunt capacitance before it rolls off as lead inductance dominates. Insertion loss increases steadily with frequency as a result of shunt capacitance. This data confirms the importance of low parasitics and a low RC product.

The fast switching time observed is shown in Figure 8. To switch from an isolation state with forward bias of 10 mA to a transmission (insertion loss) state with reverse bias of -10 volts from a 50Ω pulse source, less than 1 nanosecond is required. Much less than 1 nanosecond is needed to switch from a transmission to an isolation state.



SYMBOL	PARAMETER	SWITCH "ON"	SWITCH "OFF"	UNITS
$R_c$	Circuit Resistance	.5	.5	$\Omega$
$C_c$	Circuit Capacitance	.12	.12	pF
$L_p$	Package Inductance	.02	.02	nH
$C_p$	Package Capacitance	.02	.02	pF
$R_s$	Series Resistance	.5	.5	$\Omega$
$R_j$	Junction Resistance	20K	8	$\Omega$
$C_j$	Junction Capacitance	.1	20	pF

Figure 7. Equivalent Circuit of HPND-4050 in Microstrip Circuit.

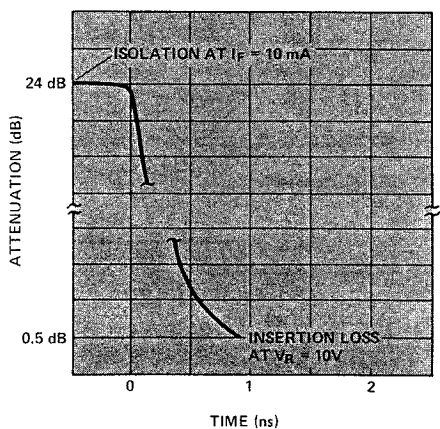

Figure 8. Beam Lead Mesa PIN Switching Time.

For the beam lead mesa PIN in shunt to switch from an isolation state with forward bias of 10 mA to an insertion loss state with reverse bias of -10V (from a 50Ω pulse source) less than 1 ns is required.

## PRACTICAL CIRCUITS

The HPND-4050 beam lead PIN diode is designed for use in stripline or microstrip circuits. Examples of strip transmission lines are shown in Figure 9. Both the coplanar parallel strip and coplanar waveguide circuits are suitable for mounting the beam lead PIN diode in the shunt configuration. In particular the coplanar waveguide circuit can be easily adapted to coaxial systems using SMA connectors. Good performance is achievable up to X-band, but requires a substrate with a relative dielectric constant of 16 or higher to accommodate the dimensions of the beam lead PIN.

With a little modification the conventional microstrip circuit lends itself easily for mounting the beam lead PIN diode in the shunt configuration. A hole through the dielectric substrate between the center conductor and the ground plane is one means for mounting a beam lead diode, but is not recommended for high volume applications.

Figure 10 shows the beam lead PIN diode mounted in the shunt configuration in a microstrip circuit which includes provision for connecting the diode to ground through a shorted stub of a half wavelength long. This technique provides an effective short at the half wavelength frequency, but the performance is limited in bandwidth. The performance data in the previous section were measured on microstrip circuits similar to this one on 25 mil substrates of relative dielectric constant 9.6.

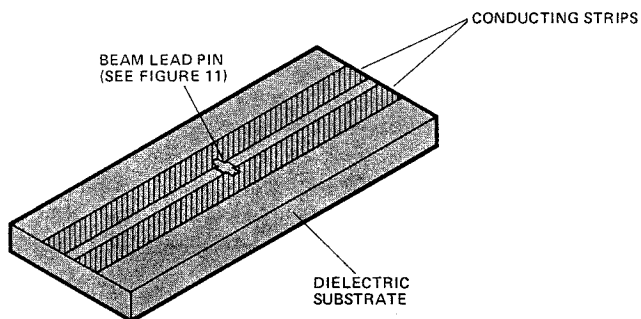

COPLANAR PARALLEL STRIPS

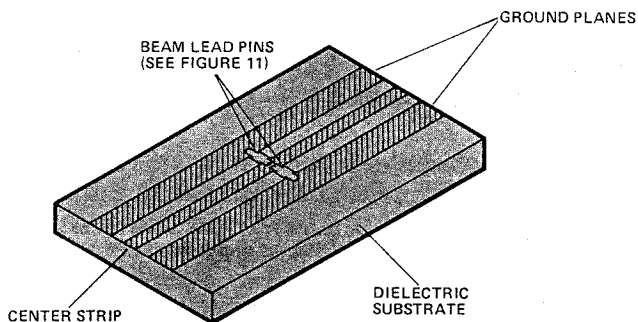

COPLANAR WAVEGUIDE (CPW)

Figure 9. Coplanar Strip Transmission Lines.

## CONCLUSION

The low RC product, fast switching time, and other unique features of the HPND-4050 beam lead PIN diode make it well suited for switching applications in the shunt configuration. Proper choice and optimum design of circuits to minimize parasitics and loss will allow these inherent characteristics of the HPND-4050 to be exploited to the fullest and achieve maximum performance.

## APPENDIX

### Handling and Bonding of the Beam Lead PIN

Beam lead PIN diodes are particularly suited for hybrid integrated circuits where low parasitics and small size (Figure 11) are prime requirements.

The beam lead diode must be handled with care, since the leads may be damaged from undue pressure as in the case with the use of tweezers. The diodes can be easily picked up, since they stick to the tip of a tweezer or the rough edge of a broken Q-tip dipped in methanol. A vacuum pickup may be used, but the vacuum hole in the needle must be sufficiently small (6 mil maximum diameter) to prevent passage of the diode. Contrary to Schottky barrier beam lead diodes, PIN's are not easily damaged by static electricity, so that no additional handling or assembly precautions need be taken except for the usual limitations imposed by the maximum voltage, power, and temperature ratings.

Thermocompression bonding is recommended for the beam lead PIN diode. The stage should be heated to 220°C and the bonding tool to 300°C maximum. Bonding time should not exceed 10 seconds. The device is positioned face down with the beam leads resting flat on the metalized contact areas of the circuit. Narrow high current pulse heating may also be used. Other techniques include ultrasonic and thermosonic bonding, epoxy, and parallel-gap welding. In the parallel gap method, current is passed through the substrate metalization and the device lead. The generation of heat is concentrated at the interface between the two, where it is needed to achieve the bonding. Many new bonders (among which are ones made by Unitek, Monrovia, California) are specifically designed to bond beam lead devices. Ultrasonic, as well as thermo-compression, models are available.

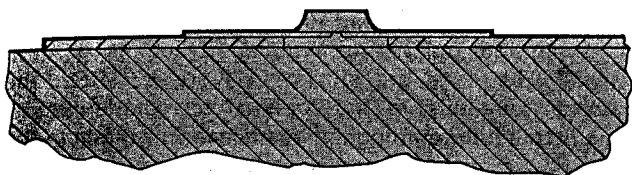

A-A SCALE = 100X

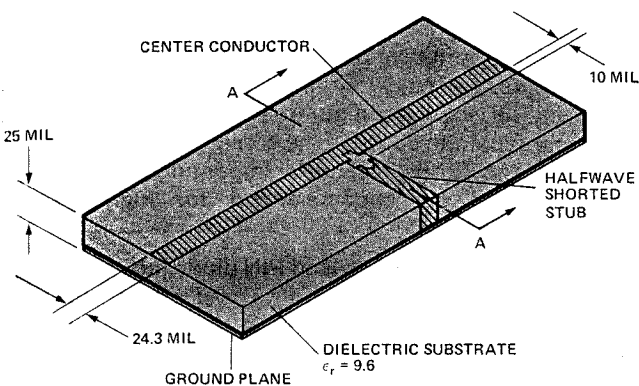

Figure 10. Beam Lead PIN diode mounted in the shunt configuration in a microstrip circuit and connected to ground through a half wave shorted stub.

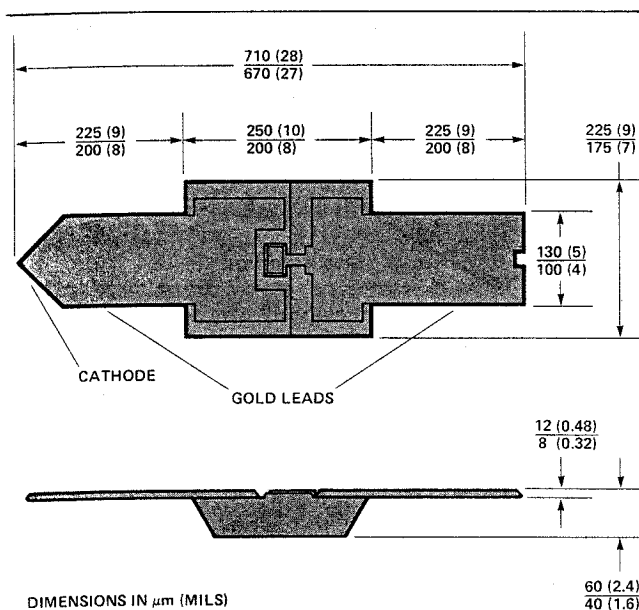

Figure 11. The small size of beam lead PIN diodes makes them suitable for hybrid integrated circuit applications.



Hewlett Packard assumes no responsibility for the use of any circuits described herein and makes no representations or warranties, express or implied, that such circuits are free from patent infringement. For more information call your local HP Sales Office or East (301) 948-6370 — Midwest (312) 255-9800 — South (404) 955-1500 — West (213) 970-7500. Or write: Hewlett-Packard Components, 350 West Trimble Road, San Jose, California 95131. In Europe, Hewlett-Packard GmbH, P.O. Box 250, Herrenberger Str. 110, D-7030 Boeblingen, West Germany. In Japan, YHP, 3-29-21, Takaide-Higashi, Suginami Ku, Tokyo 168.