

An Optimum Zero Bias Schottky Detector Diode

INTRODUCTION

A conventional Schottky diode detector such as the Hewlett-Packard 5082-2750 or 5082-2824 requires no bias for high level input power — above one milliwatt. However, at low levels, a small amount of dc bias is required for detection to take place. Even though this bias current is at the microampere level, this requirement is often difficult to supply. A new Schottky diode has been developed to eliminate this need for dc bias. This new diode is also 2 or 3 times more efficient as a detector compared to conventional biased detectors.

FORWARD VOLTAGE CHARACTERISTIC

Since all diodes in this discussion are Schottky diodes, the forward current obeys the equation:

$$I = I_S \left(e^{\frac{q}{nkT} (V - IR_S)} - 1 \right)$$

The ideality factor, n , is close to unity for these diodes, so the equation may be written:

$$I = I_S \left(e^{\frac{V - IR_S}{.026}} - 1 \right)$$

where the values for the constants q , electron charge, T , room temperature, and k , Boltzmann's constant, have been inserted. The main difference in the behavior of the different types of diodes is embodied in I_S , the saturation current. There may also be minor differences in R_S , the series resistance.

Figure 1 shows the forward current characteristics of the 5082-2750 detector diode and two versions of zero bias diodes, HSCH-3171 and HSCH-3486. These curves are close to the curves predicted by the diode equation with the constants shown in Table 1.

Table 1

Diode	I_S (amperes)	R_S (ohms)
5082-2750	7×10^{-10}	32
HSCH-3171	7×10^{-8}	15
HSCH-3486	6×10^{-6}	15

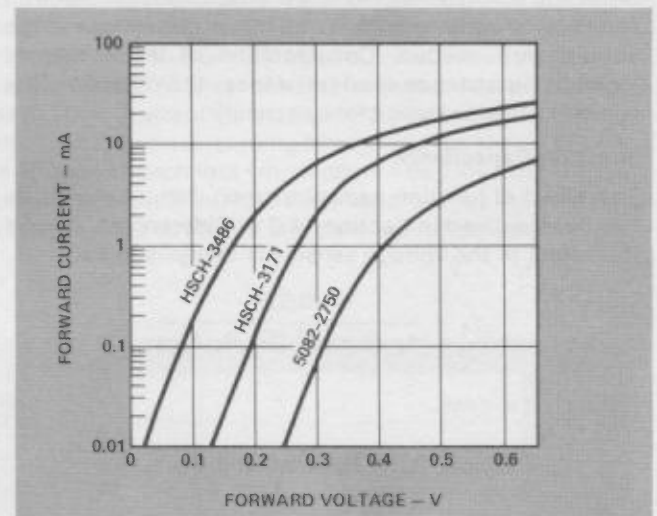

Figure 1. Forward Characteristics of Detector Diodes.

VOLTAGE SENSITIVITY

A detector diode may be treated as a current generator across the diode video resistance. (1) The voltage sensitivity, γ , is the product of the current sensitivity, β , and the video resistance, the inverse of the derivative of current with respect to voltage.

The Perfect Detector

Neglecting parasitic and reflection losses:

$$\gamma = \beta / \frac{\partial I}{\partial V}$$

For small values of current:

$$I = I_S \left(e^{\frac{V}{.026}} - 1 \right)$$

$$\text{and } \frac{\partial I}{\partial V} = \frac{I + I_S}{.026}$$

The theoretical current sensitivity is 20 amperes per watt(2) so:

$$\gamma = \frac{0.52}{I + I_S}$$

or, for zero bias current:

$$\gamma = \frac{0.52}{I_S}$$

This analysis indicates no improvement in using the new diodes because sensitivity varies inversely as saturation current and the standard 5082-2750 diode has the lowest saturation current. In fact, no improvement is needed since the sensitivity is:

$$\gamma = \frac{0.52}{7 \times 10^{-10}} = 750 \times 10^6 \text{ volts per watt}$$

or 750,000 millivolts per microwatt.

Since the actual sensitivity of the 5082-2750 detector with zero bias is close to zero, some major corrections in the analysis are needed. Consideration of the effects of junction capacitance, load resistance, and reflection loss will bring this analysis close to reality.

Junction Capacitance

The effect of junction capacitance on current sensitivity has been derived in Section 11.2 of Reference 1. Adding this effect to the voltage sensitivity analysis gives:

$$\gamma_1 = \frac{0.52}{I_S (1 + \omega^2 C_j^2 R_S R_V)}$$

For a typical case,

$$C_j = .07 \text{ pF}, R_S = 15 \text{ ohms, and } R_V = \frac{.026}{I_S}$$

so that:

$$\gamma = \frac{6900}{f^2 + 1.33 \times 10^7 I_S} \quad \frac{\text{mV}}{\mu\text{W}}$$

with frequency in gigahertz and saturation current in amperes. Figure 2 shows how capacitance modifies voltage sensitivity. Since the change is due to the rf current split between C_j and R_V , the reduction is more severe at higher frequencies, when the capacitive susceptance is higher. The inverse relationship with saturation current is still present at low frequencies or high saturation current values. However, predicted values of voltage sensitivity are still unreasonably high.

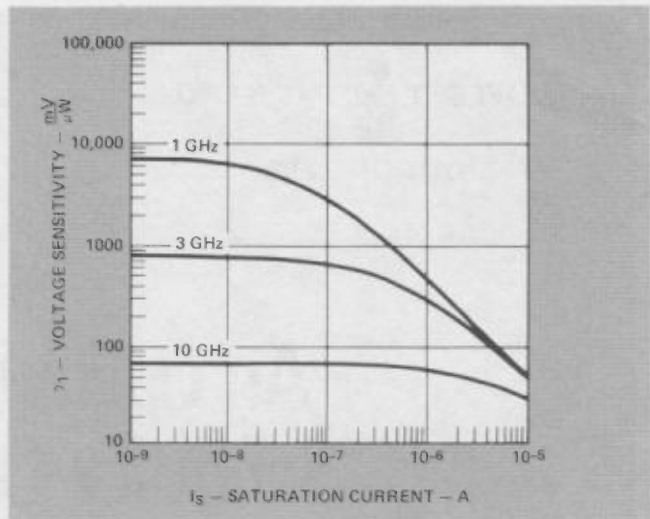

Figure 2. Effect of Capacitance on Voltage Sensitivity.

Load Resistance

A detector diode may be considered as a video voltage source of impedance R_V feeding a load resistance R_L . The voltage across the load, γ_2 , is reduced by the ratio of R_L to $R_V + R_L$:

$$\gamma_2 = \gamma_1 \frac{R_L}{R_V + R_L} = \frac{\gamma_1}{1 + \frac{R_V}{R_L}}$$

When the ratio of video resistance to load resistance is small, $\gamma_2 = \gamma_1$. This is a common condition for biased detectors. However, at zero bias, the diode resistance is usually not small compared to load resistance. For a typical load resistance value of one megohm, the sensitivity is:

$$\gamma_2 = \frac{\gamma_1}{1 + \frac{26 \times 10^{-9}}{I_S}}$$

The effect of load resistance is shown in Figure 3. The inverse relationship between sensitivity and saturation current in γ_1 combined with the direct relationship due to load resistance results in a maximum voltage sensitivity when $I_S = 4.43 \times 10^{-8}$ A. However, these theoretical results are still unreasonably high, particularly at the lower frequencies.

Reflection Loss

The analysis so far has assumed that all incident power is absorbed by the diode. Normally this is a good assumption because low loss matching circuits can be designed to eliminate reflection losses. With zero bias detectors, however, the mismatch may be so severe that it is not possible to eliminate these reflection losses. In fact, most of the incident power may be absorbed by losses in the matching network. If we go to the other extreme and assume no matching, the sensitivity becomes:

$$\gamma_3 = \gamma_2 (1 - \rho^2)$$

where ρ is the reflection coefficient of the diode. Assuming the diode impedance, Z_D , terminates a 50 ohm system:

$$\rho = \frac{Z_D - 50}{Z_D + 50}$$

The diode impedance is a function of the package parasitics as well as the frequency.

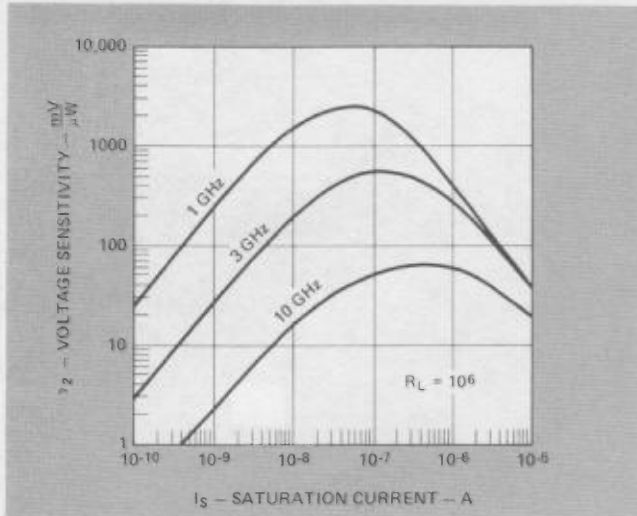

Figure 3. Effect of Load Resistance and Capacitance on Sensitivity.

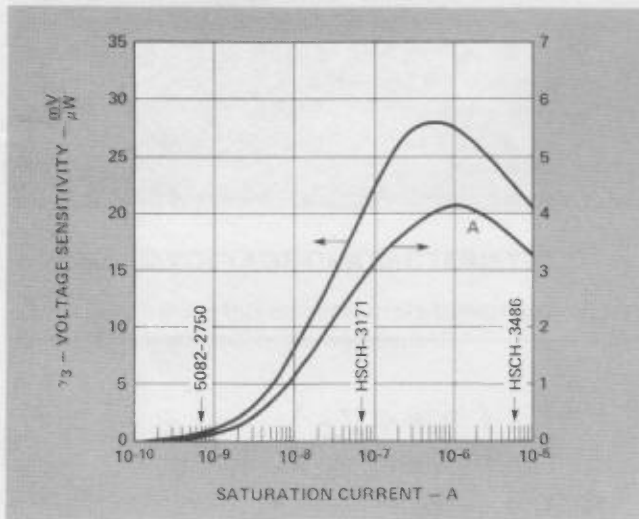

Figure 4. Effect of Mismatch, Load Resistance and Capacitance on Sensitivity.

Figure 4 shows the effect of mismatch loss on sensitivity. The package parasitics of outlines 44, 49 and 15 were considered at 1, 3 and 10 GHz. The results were all quite close to Curve A in Figure 4 with the exception of outline 15 at 10 GHz. At this frequency the high package inductance of outline 15 nearly resonates the circuit capacitance so that the reflection losses are not so severe.

With the addition of tuning to overcome some of the reflection losses, the measured sensitivity of the Hewlett-Packard zero bias detectors usually exceeds the values of Figure 4. However, the reflection losses for the 5082-2750 detector are so great that tuners do not help much. These diodes are not useful without bias. The measured sensitivity of the HSCH-3486 is less than the value predicted by Figure 4. Apparently a more complete analysis would shift the curve to the left.

TEMPERATURE EFFECT

Conventional Schottky diode detectors improve at colder temperatures. This behavior is similar to that of the HSCH-3486 diode whose temperature characteristic is shown in Figure 5. When matching losses are small, the sensitivity varies inversely as saturation current, improving at low temperatures.

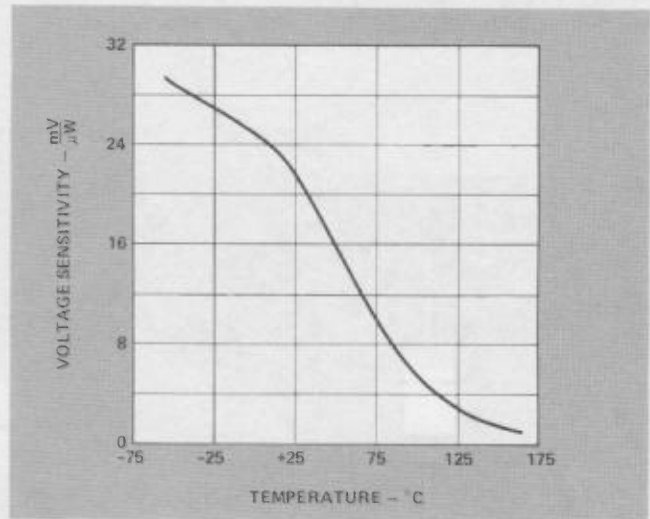

Figure 5. Temperature Characteristics, HSCH-3486.

Figure 6 shows the temperature characteristic of diode HSCH-3171. This diode has maximum sensitivity just above room temperature, degrading at cold as well as at hot temperatures. The high temperature behavior is expected from the higher value of saturation current. The low temperature behavior indicates that the room temperature value of saturation current is nearly optimum for this diode. At lower temperatures the reduced value of saturation current is not able to improve sensitivity because the corresponding large diode resistance causes a large mismatch loss which cannot be tuned out. At low temperatures, diode HSCH-3171 approaches the behavior of diode 5082-2750, the standard biased detector.

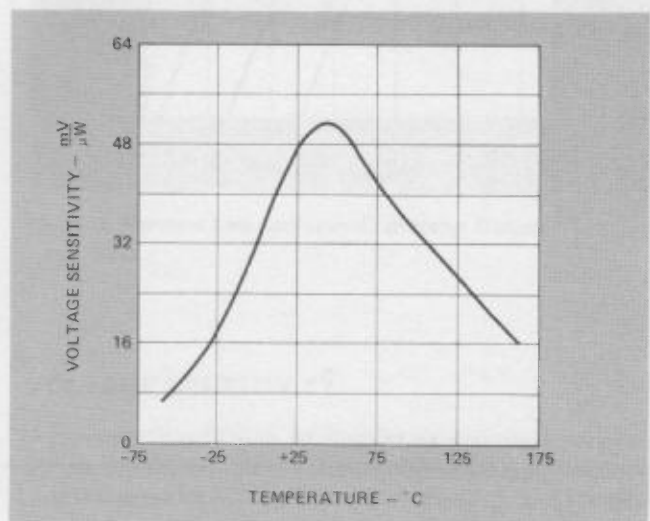

Figure 6. Temperature Characteristics, HSCH-3171.

SUMMARY

Detector diodes are most sensitive at zero bias when the saturation current is small, corresponding to large video resistance. However, there is a limit to sensitivity when the resistance is so large that it cannot be matched. An optimum diode is designed to have the proper saturation current. Choice of saturation current involves a compromise between sensitivity due to large resistance and loss due to matching.

REFERENCES

1. Torrey, H. C. and Whitmer, C. A., "Crystal Rectifiers", MIT Radiation Laboratory Series, Vol. 15, McGraw-Hill (New York) 1948.
2. Watson, H. A., "Microwave Semiconductor Devices and Their Circuit Applications", p. 379, McGraw-Hill, 1969.

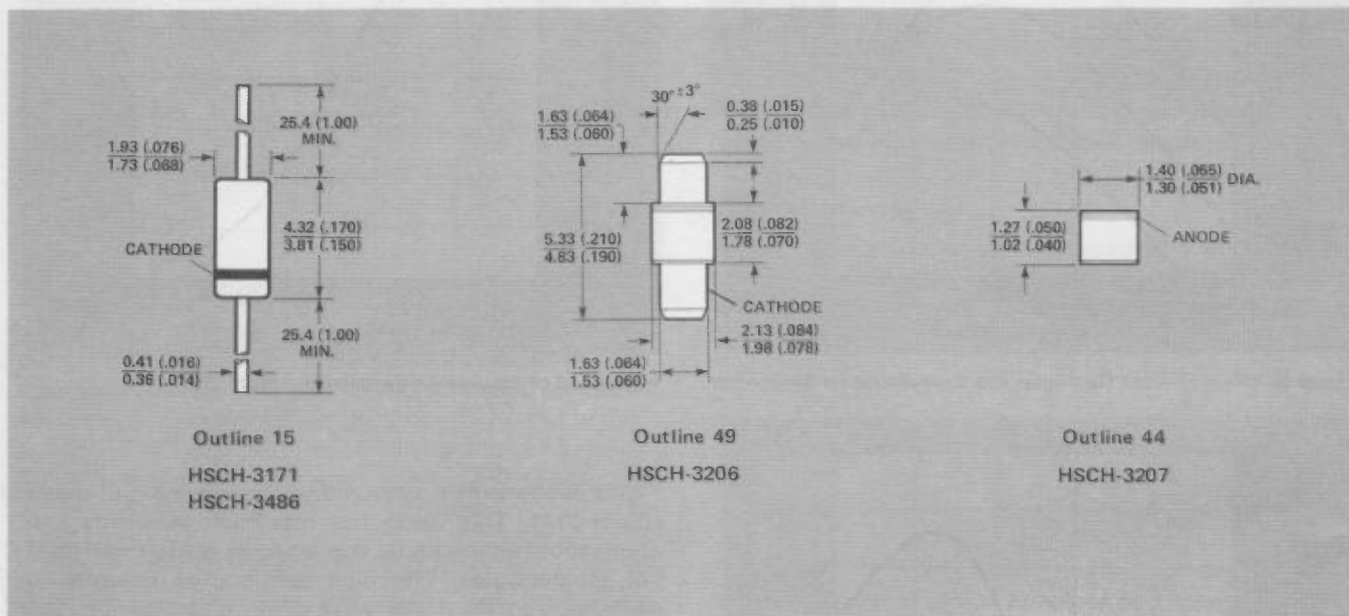

Figure 7. Package Outlines for Zero Bias Schottky Diodes.

Hewlett Packard assumes no responsibility for the use of any circuits described herein and makes no representations or warranties, express or implied, that such circuits are free from patent infringement.

For more information, call your local HP Sales Office or East (301) 948-6370 - Midwest (312) 677-0400 - South (404) 434-4000 - West (213) 877-1282. Or write: Hewlett-Packard Components, 640 Page Mill Road, Palo Alto, California 94304. In Europe, Post Office Box 85, CH-1217, Meyrin 2, Geneva, Switzerland. In Japan, YHP, 1-59-1, Yoyogi, Shibuya-Ku, Tokyo, 151.