

IMPATT Amplifier

CONTENTS

- I. INTRODUCTION
- II. AMPLIFIER LOAD IMPEDANCE
- III. A WAVEGUIDE AMPLIFIER
Adjusting the Center Frequency Bandwidth
- IV. A COAXIAL AMPLIFIER
- V. CONCLUSION

INTRODUCTION

Hewlett-Packard IMPATT diodes are specified as oscillators. Each diode is tested in a coaxial cavity and guaranteed to deliver more than the specified power output. The details of these test cavities are available.

Although tested as oscillators, these diodes are equally useful as amplifiers. In general, the added power in amplifier applications is the same as the output power in oscillator applications.

AMPLIFIER LOAD IMPEDANCE

While the proper oscillator load impedance is the complex conjugate of the diode impedance, the amplifier load impedance is related to the voltage gain, G , by the expression:

$$G = \left(\frac{Z_L - Z_D^*}{Z_L + Z_D} \right)^2$$

where $Z_L = R_L + jX_L$ and $Z_D = R_D + jX_D$ are load and diode impedances, and Z_D^* is the complex conjugate of the diode impedance.

We can choose $X_L = -X_D$ so that the gain expression becomes:

$$G = \left(\frac{R_L - R_D}{R_L + R_D} \right)^2$$

Amplifier design is thus very similar to oscillator design. In both cases, the load resonates the diode. In amplifier design, the load resistance is higher than the oscillator load resistance.

A WAVEGUIDE AMPLIFIER

A waveguide amplifier with 10 dB gain at 11.2 GHz was designed and built with a 5082-0611 diode. Output power is 2 watts.

The basic circuit is shown in Figure 1. The coaxial section starts at the center of the waveguide. The waveguide ends in a short one quarter wavelength (8.26 mm) from the center of the coaxial section. Three dimensions must be chosen: the inner and outer diameters of the coaxial line and its length.

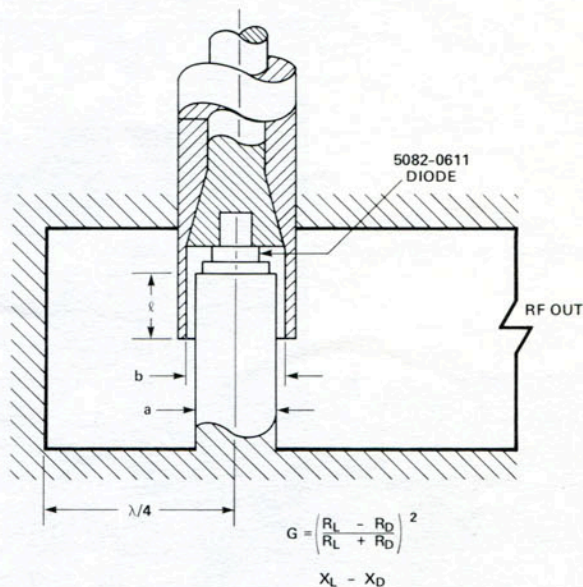

COAXIAL TRANSFORMER DESIGNED TO TRANSFORM 200 OHM WAVEGUIDE IMPEDANCE TO DESIRED LOAD IMPEDANCE

Figure 1. Waveguide Circuit.

It is convenient to split the waveguide in half at the center H plane and consider the post as part of a trough line terminating the half waveguide. The trough line impedance is related to the post diameter and should match the half waveguide impedance or 100 ohms.¹ The post diameter, a , providing this impedance is 3.63 mm.²

Similarly, the outer conductor of the coaxial section forms a trough line whose impedance is somewhat less than the lower trough line. Although ideally the 2 trough lines would be made the same impedance, it is mechanically easier, and generally electrically acceptable to use a constant diameter post. By choosing the trough line impedance approximately equal to the half-waveguide impedance, the impedance seen at the center of the waveguide at the outlet of the coax line is the sum of the 2 trough line impedances, which is approximately the full waveguide impedance.

Now the coaxial line may be considered as a transformer of impedance Z_0 , transforming the 200 ohm waveguide impedance to Z_L , the desired load impedance by the relationship:

$$Z_L = Z_0 \frac{200 + jZ_0 \tan \Theta}{Z_0 + j200 \tan \Theta} = R_L + jX_L.$$

The load reactance is -11 ohms, the negative of the diode reactance given in the data sheet.

The load resistance is calculated from the gain formula

$$G = \left(\frac{R_L - R_D}{R_L + R_D} \right)^2 = 10$$

The diode resistance, R_D , is approximately -0.7 ohm — the typical large signal resistance obtained from the data sheet. The load resistance, R_L , is calculated to be 1.35 ohms from the above gain formula.

Now the coaxial line impedance Z_0 and the electrical length $\Theta = 2\pi \frac{\ell}{\lambda}$ may be calculated to be 12.2 ohms and

47.5°. This corresponds to $\ell = 3.53$ mm and $b/a = 1.225$ from $Z_0 = 138 \log b/a = 12.2$. The graph of Figure 2 may be used find b/a and $\frac{\ell}{\lambda}$ directly. Since a is 3.63 mm, $b = 1.225 \times 3.63 = 4.45$ mm, and the design is completed. Since the data sheet impedance may not be exactly right for this particular diode, this initial design may not operate at the desired gain and frequency. In that case, the measured performance will be used to calculate a more accurate diode impedance. A second circuit design will then be calculated.

When the amplifier was first tested, oscillations were observed at 11.9 GHz with no input signal applied. This might have been expected, since the data sheet shows the typical small signal diode resistance at 11.9 GHz to be -1.5 ohms, close to the 1.35 ohm load resistance at 11.2 GHz. Although this oscillation ends when input power reduces the magnitude of the diode resistance, this condition is not desirable. Many amplifier applications require stability at all input power levels.

To achieve this stability, the load impedance was raised by decreasing dimension "a" to 3.53 mm, raising the coaxial line impedance Z_0 to 13.8 ohms and the load impedance to $1.74 - j12.5$ at 11.2 GHz.

This design was stable, but the design goals were not met. Center frequency was 11.8 GHz and the gain was 8.8 dB at 200 mW input level. At this frequency the load impedance is $1.62 - j11.5$.

Now we can use this load impedance and the measured gain to calculate a more accurate diode impedance, a new

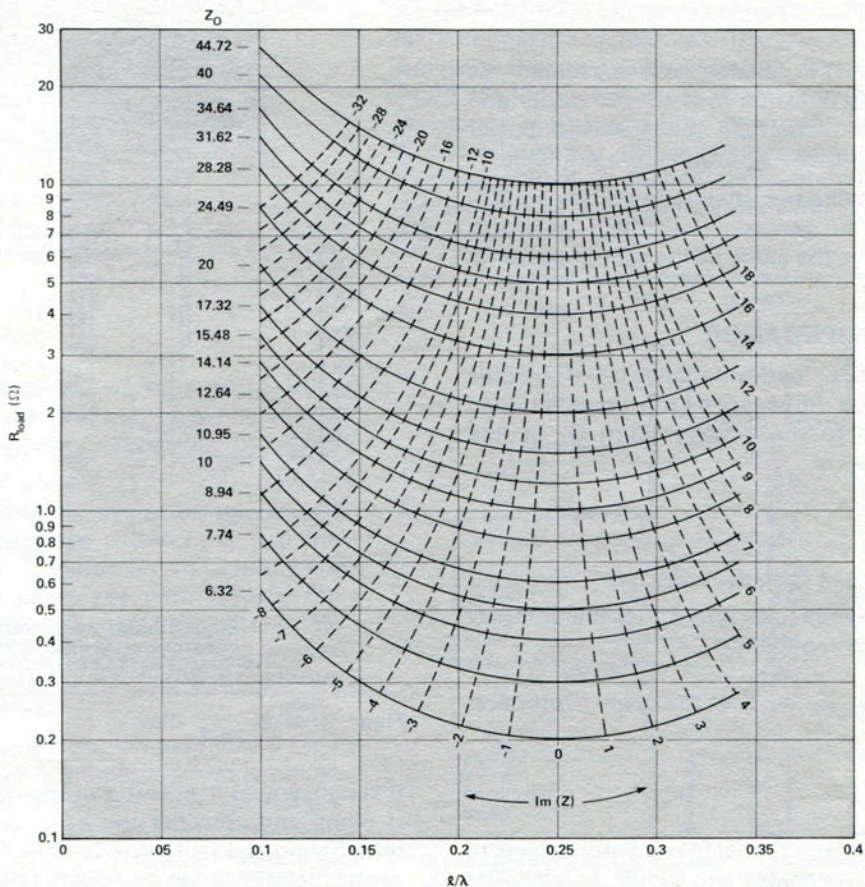

Figure 2. Design Aid for Waveguide Circuit.

load impedance and then a new transformer to meet the design goal:

$$R_D = R_L \frac{1 - \sqrt{G}}{1 + \sqrt{G}} = -0.76 \text{ ohm} \quad X_D = -X_L = 11.5 \text{ ohms}$$

This is the diode impedance at 11.8 GHz. To find the 11.2 GHz impedance, assume the impedance functions have the same slope as the typical curves on the data sheet. The result is $Z_D = -0.82 + j9$.

For 10 dB gain, the load resistance should be:

$$R_D \frac{1 + \sqrt{G}}{1 - \sqrt{G}} = -0.82 \frac{1 + \sqrt{10}}{1 - \sqrt{10}} = 1.58 \text{ and } Z_L = 1.58 - j9.$$

The transformer equation gives $a = 3.45 \text{ mm}$ and a transformer length of 4.42 mm . Again the initial test showed oscillations with no input power. However, changing the inner conductor diameter, a , to 3.15 mm and the transformer length, ℓ , to 4.80 mm produced a stable amplifier at the 11.2 GHz design frequency.

Figure 3 shows the amplifier performance at 200 mA bias current. At center frequency the gain is 10 dB and the output 2 watts . Junction temperature is calculated to be 215°C , within the recommended limit of 250°C .

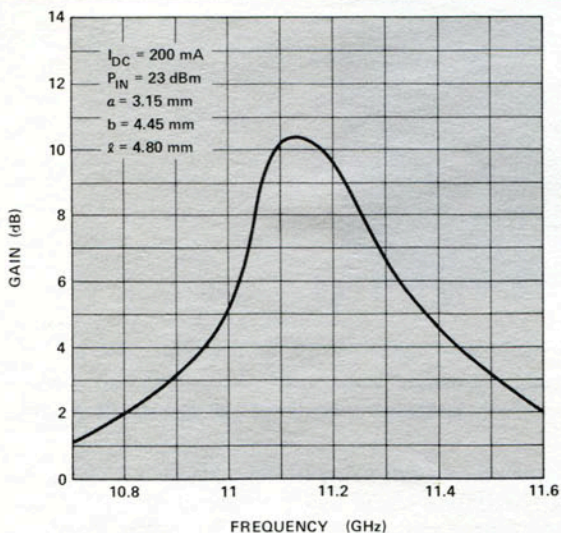

Figure 3. Waveguide Amplifier Frequency Response.

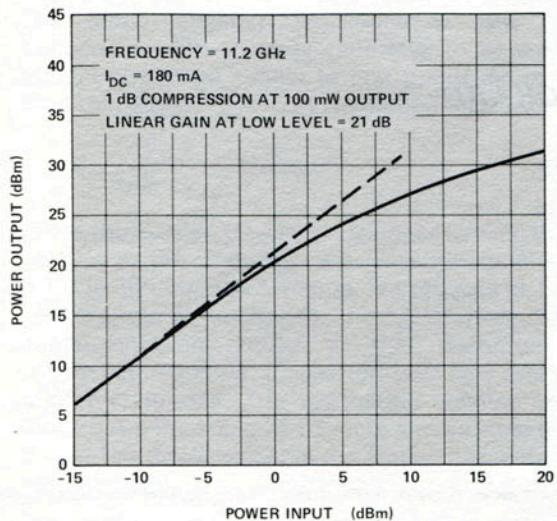

Figure 4. Waveguide Amplifier Transfer Characteristic.

The transfer characteristic of this amplifier is shown in Figure 4. The response is linear with 20 dB gain at input power levels below one milliwatt.

Adjusting the Center Frequency

We have shown how the frequency may be shifted by adjusting the dimensions of the coaxial transformer. Figures 5 and 6 show two other frequency sensitive dimensions which may be easier to change.

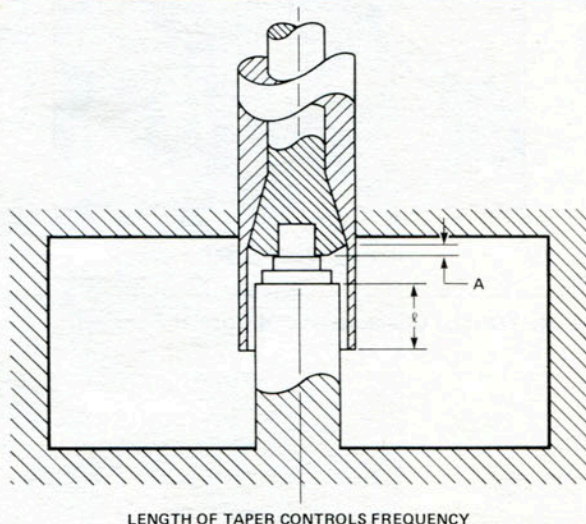

Figure 5. Taper Modification.

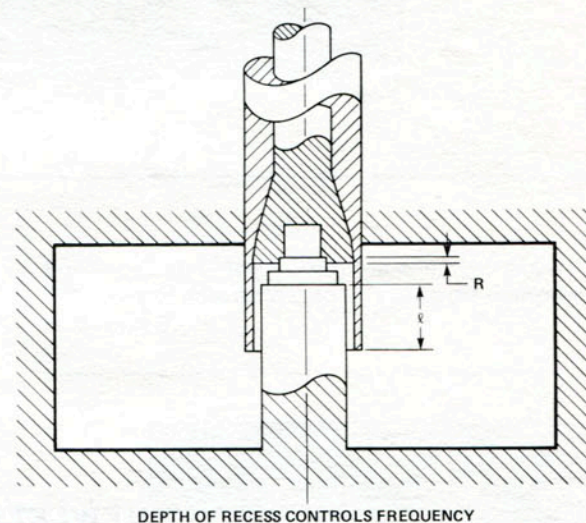

Figure 6. Diode Recess Modification.

The effect of increasing the taper length, A , is shown in Figure 7. Frequency decreases as A increases. The result is similar to increasing ℓ , the length of the transformer.

The effect of increasing the diode recess, R , is shown in Figure 8. Frequency increases as the recess depth increases. As discussed in AN 935, recessing the diode raises the frequency by lowering the package inductance.

Although frequency change is the major effect of these dimension changes, the gain is also affected. The real and imaginary parts of the load impedance are both affected by any dimension change, so that both gain and center frequency may be expected to change. This is particularly noticeable in Figure 8 for changes in diode recess.

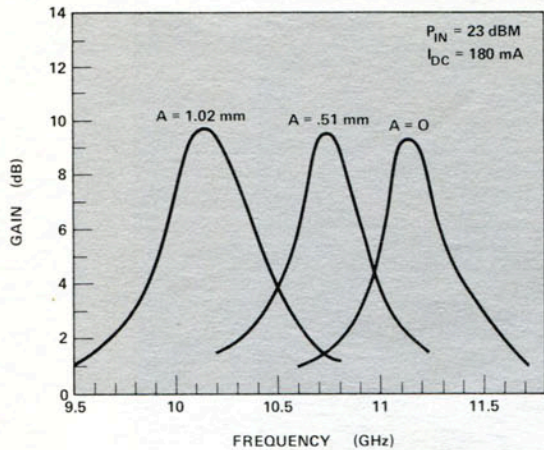

Figure 7. Taper Tuning.

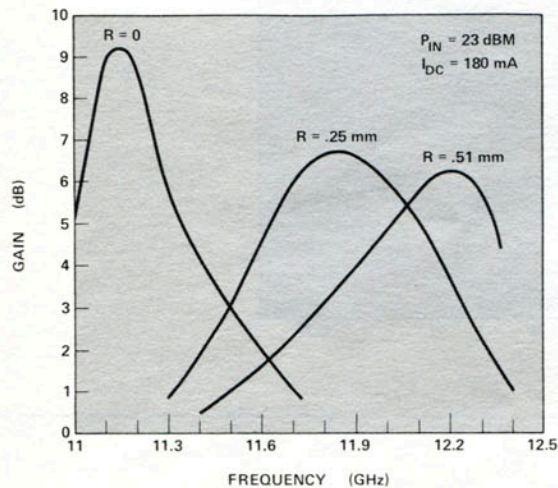

Figure 8. Recess Tuning.

Bandwidth

Typical 3 dB bandwidth obtained with this single step transformer design is less than 5%. Application Note 935 shows that some improvement is possible by using multiple step transformers.

A more effective technique is the use of an impedance inverter between the single stage transformer and the diode. Because a single step transformer and a diode are both approximated by a series resonant circuit, the bandwidth of the combination is relatively narrow. By inverting the impedance of the transformer with a quarter wave line, it becomes a shunt resonant circuit at the diode and the bandwidth is widened.

An example of this technique is shown in Figure 9 for a 5082-0424 diode. The 3 ohm transmission line is not an impedance transformer. The 12.25 ohm line has already transformed the 50 ohm line to a 3 ohms series resonant circuit. The 3 ohm line then inverts this impedance to approximate a parallel resonant circuit. Combining this with the series resonant diode results in the broad band amplifier response shown in Figure 10.

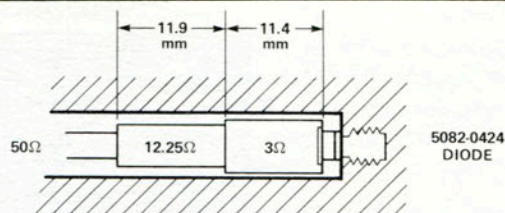

Figure 9. Broadband Amplifier — 6.5 GHz.

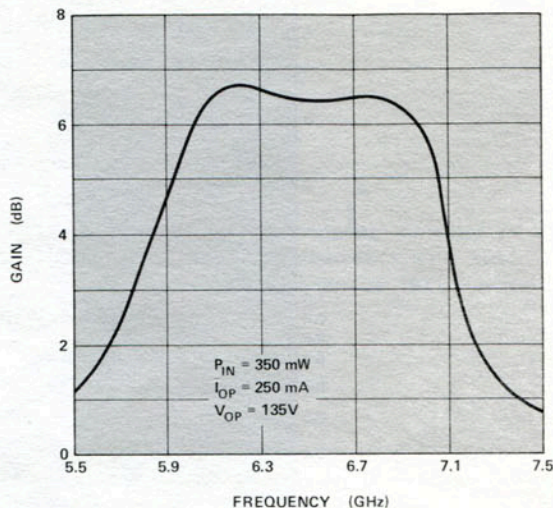

Figure 10. Frequency Response of Broadband Amplifier.

A COAXIAL AMPLIFIER

An HP 5082-0608 diode was used to demonstrate coaxial amplifier design techniques. The procedure is somewhat similar to the waveguide design. A coaxial transformer is again used to transform the 50 ohm line impedance to the resistance required for the desired gain. However, the circuit (Figure 11) also contains a spacer to control the diode reactance. Spacers of different thickness and inner diameter can be used with the same transformer to change the operating frequency.

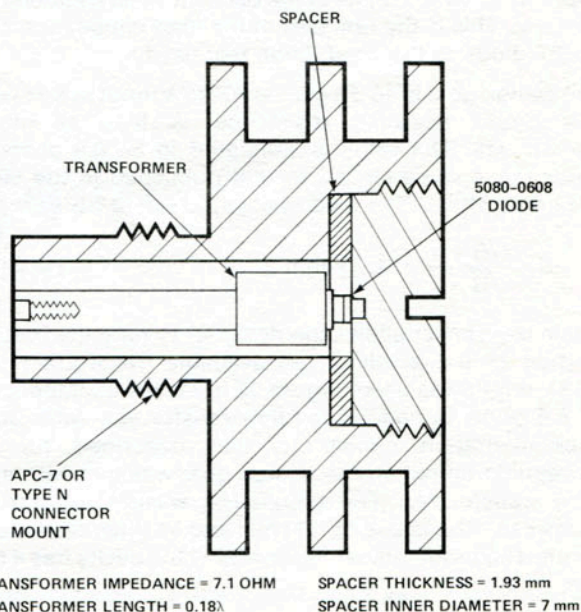

Figure 11. Coaxial Circuit.

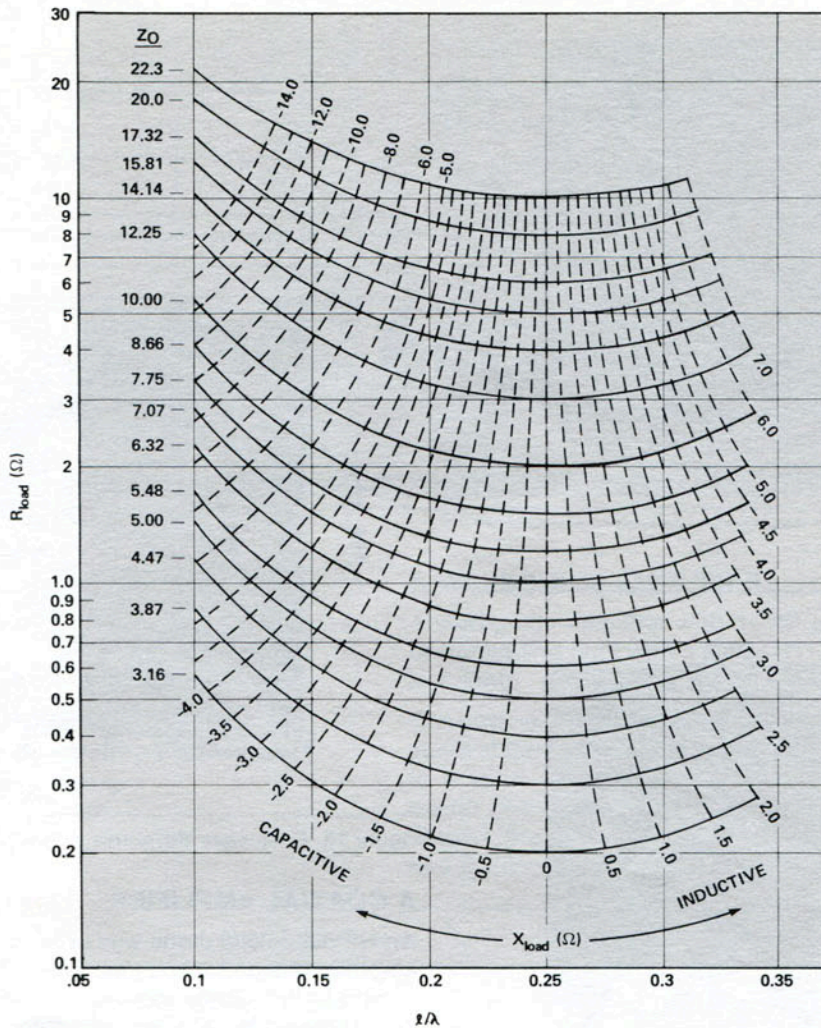

Figure 12. Design Aid for Coaxial Amplifier.

Figure 12 may be used to solve the transformer equation for a 50 ohm generator. The diode negative resistance is approximately 1.1 ohms at the oscillator test frequency of 7.2 GHz. This is the real part of the load impedance seen by the diode in the production test cavity.

The design goal is 10 dB gain at 200 mW input at 8.35 GHz. The diode negative resistance is less at higher frequencies. The value is estimated to be 0.9 ohms by assuming a slope similar to that published in the 5082-0611 data sheet. The load resistance for 10 dB gain is:

$$-R_D \frac{\sqrt{G} + 1}{\sqrt{G} - 1} = 1.73 \text{ ohm}$$

Since the spacer allows the designer to tune the reactive portion of the amplifier, an available transformer with 0.18λ length was used. Figure 12 indicates an impedance of 8.5 ohms is needed for the transformer. After some experimentation similar to that described for the waveguide amplifier, the design goal was met with a 7.1 ohm transformer. The resonating washer around the diode has a thickness of 1.93 mm and an inner diameter of 7 mm. The diode holder at the end of the cavity has a 5.08 mm diameter.

Figure 13 shows the frequency response of the amplifier. The 3 dB bandwidth is 320 MHz, similar to the

performance of the waveguide amplifier. Figure 14 shows the transfer characteristic. The one dB compression level is 10 mW input.

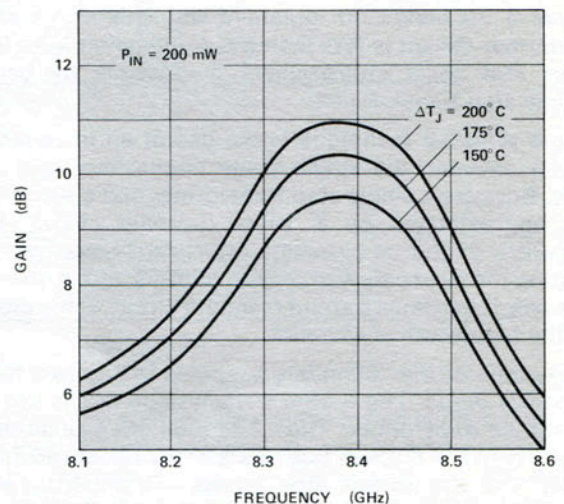

Figure 13. Frequency Response of Coaxial Amplifier.

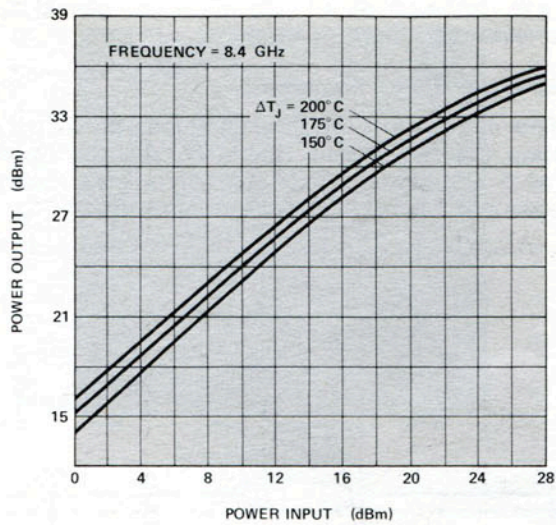

Figure 14. Transfer Characteristic of Coaxial Amplifier.

CONCLUSION

Stable amplifiers may be designed in various transmission lines with Hewlett-Packard IMPATT diodes. Because the diode impedance varies with bias current, gain, and input power level, it is usually necessary to make two or three iterations to reach the design goal.

REFERENCES

1. S.A. Schelkunoff, "Impedance Concept in Waveguides", Quarterly of Applied Mathematics, April 1944.
2. Microwave Engineer's Handbook, 1971, Horizon House, Vol. I, p. 95.



Hewlett Packard assumes no responsibility for the use of any circuits described herein and makes no representations or warranties, express or implied, that such circuits are free from patent infringement.

For more information, call your local HP Sales Office or East (301) 948-6370 - Midwest (312) 677-0400 - South (404) 434-4000 - West (213) 877-1282. Or write: Hewlett-Packard Components, 640 Page Mill Road, Palo Alto, California 94304. In Europe, Post Office Box 85, CH-1217, Meyrin 2, Geneva, Switzerland. In Japan, YHP, 1-59-1, Yoyogi, Shibuya-Ku, Tokyo, 151.