

Linear Applications of Optically Coupled Isolators

W105

Optically coupled isolators are useful in applications where analog or DC signals need to be transferred from one module to another in the presence of a large potential difference or induced noise between the ground or common points of these modules.

Potential applications are those in which large transformers, expensive instrumentation amplifiers or complicated A/D conversion schemes are used. Examples are: sensing circuits (thermocouples, transducers . . .), patient monitoring equipment, power supply feedback, high voltage current monitoring, adaptive control systems, audio amplifiers and video amplifiers.

HP's opto isolators have integrated photodetector/amplifiers with speed and linearity advantages over conventional phototransistors. In a photo transistor, the photodetector is the collector-base junction so the capacitance impairs the collector rise time. Also, amplified photocurrent flows in the collector-base junction and modulates the photo-response, thereby causing non-linearity. The photodetector in an HP opto isolator is a separately integrated diode so its photoresponse is not affected by amplified photocurrent and its capacitance does not impair speed. Some linear isolation schemes employ digital conversion techniques (A/D-D/A, PWM, PCM, etc.) in which the higher speed of the integrated photodetector permits better linearity and bandwidth.

The 5082-4350/1/2 is recommended for single channel AC analog designs. The 5082-4354/5 is recommended for dual channel DC linear designs. The 5082-4350 series or the 5082-4360 series are recommended for digital conversion schemes.

If the output transistor is biased in the active region, the current transfer relationship for the 5082-4350 series opto isolator can be represented as:

$$I_C = K \left(\frac{I_F}{I_F'} \right)^n$$

where I_C is the collector current; I_F is the input LED current; I_F' is the current at which K is measured; K is the collector current when $I_F = I_F'$; and n is the slope of I_C vs. I_F on logarithmic coordinates.

The exponent n varies with I_F , but over some limited range of ΔI_F , n can be regarded as a constant. The current transfer relationship for an opto isolator will be linear only if n equals one.

For the 5082-4350 series opto isolators, n varies from approximately 2 at input currents less than 5mA to approximately 1 at input currents greater than 16mA. For AC coupled applications, reasonable linearity can be obtained with a single opto isolator. The opto isolator is biased at higher levels of input LED current where the ratio of incremental photodiode current to incremental LED current ($\partial I_D / \partial I_F$) is more nearly constant.

For better linearity and stability, servo or differential linearization techniques can be used.

The servo linearizer forces the input current of one opto isolator to track the input current of the second opto isolator by servo action. Thus, if $n_1 = n_2$ over the excursion range, the non linearities will cancel and the overall transfer function will be linear. In the differential linearizer, an input signal causes the input current of one opto isolator to increase by the same amount that input current of the second opto isolator is decreased. If $n_1 = n_2 = 2$, then a gain increment in the first opto isolator will be balanced by a gain decrement in the second opto isolator and the overall transfer function will be linear. With these techniques, matching of K will not effect the overall linearity of the circuit but will simplify circuit realization by reducing the required dynamic range of the zero and offset potentiometers.

Gain and offset stability over temperature is dependent on the stability of current sources, resistors, and the optically coupled isolators. For the servo technique, changes of K over temperature will have only a small effect on overall gain and offset as long as the ratio of K_1 to K_2 remains constant. With the differential technique, changes of K over temperature will cause a change in gain of the circuit. Offset will remain stable as long as the ratio of K_1 to K_2 remains constant. In the AC circuit, since $(\partial I_D / \partial I_F)$ varies with temperature, the gain will also vary with temperature. A thermister can be used in the output amplifiers of the Differential and AC circuits to compensate for this change in gain over temperature.

There are also several digital techniques to transmit an optically coupled isolated analog signal. Optical isolators can be used to transmit a frequency or pulse width modulated signal. In these applications, overall circuit bandwidth is determined by the required linearity as well as the propagation delay of the opto isolators. The 5082-4360 series opto isolator features propagation delays

typically less than 50ns and the 5082-4350 series opto isolator features propagation typically less than 300ns.

In several places the circuits shown call for a current source. They can be realized in several ways. If V_{CC} is stable, the current source can be a mirror type circuit as shown in Figure 1.

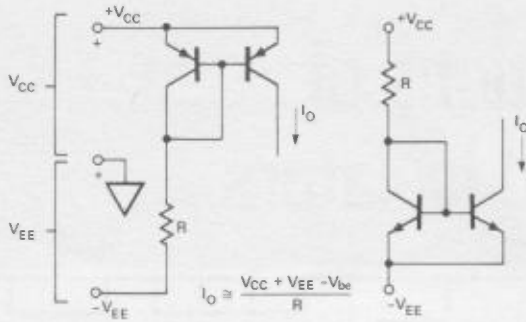

Figure 1.

If V_{CC} is not stable, a simple current source such as the ones shown in Figure 2 can be realized with an LED as a voltage reference. The LED will approximately compensate the transistor over temperature since $\Delta V_{BE} / \Delta T \cong \Delta V_F / \Delta T = -2mV/^{\circ}C$:

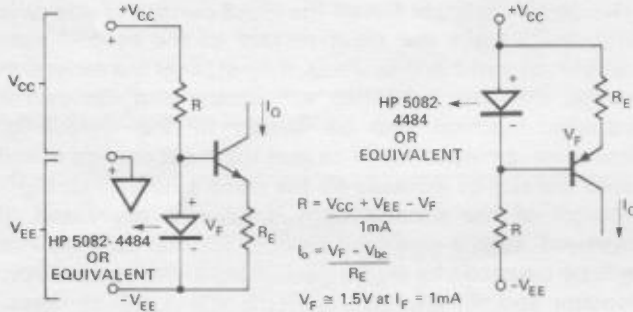

Figure 2.

SERVO ISOLATION AMPLIFIER

The servo amplifier shown in Figure 3 operates on the principle that two opto isolators will track each other if their gain changes by the same amount over some operating region. U_2 compares the outputs of each opto isolator and forces I_{F2} through D_2 to be equal to I_{F1} through D_1 . The constant current sources bias each I_F at 3mA quiescent current. R_1 has been selected so that I_{F1} varies over the range of 2mA to 4mA as V_{IN} varies from -5V to +5V. R_1 can be adjusted to accommodate any desired range. With $V_{IN}=0$, R_2 is adjusted so that $V_{OUT} = 0$. Then with V_{IN} at some value, R_4 can be adjusted for a gain of 1. Values for R_2 and R_4 have been picked for a worst case spread of opto isolator current transfer ratios. The transfer function of the servo amplifier is:

$$V_{OUT} = R_4 \left[\left(\frac{I_{F2}}{I_{F1}} \right) \left(\frac{K_1 R_2 (I_{CC1})^{n_1}}{K_2 R_3 (I_{F1})^{n_1}} \right)^{1/n_2} \left(1 + \frac{V_{IN}}{R_1 I_{CC1}} \right)^{n_1/n_2} - I_{CC2} \right]$$

After zero adjustment, this transfer function reduces to:

$$V_{OUT} = R_4 I_{CC2} \left[(1+x)^n - 1 \right], \text{ where } x = \frac{V_{IN}}{R_1 I_{CC1}}, n = \frac{n_1}{n_2}$$

The non linearities in the transfer function where $n_1 \neq n_2$ can be written as shown below. For example, if $|x| \leq .35$, $n = 1.05$, then the linearity error is 1% of the desired signal.

$$\frac{\text{linearity error}}{\text{desired signal}} = \frac{(1+x)^n - n x - 1}{n x}$$

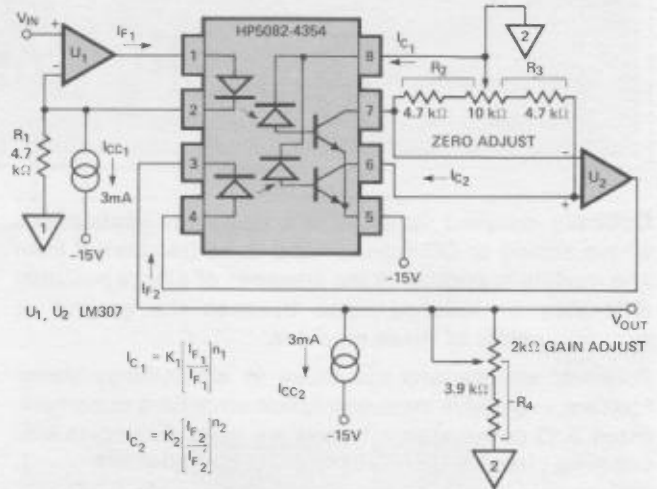

Figure 3. Servo Type DC Isolation Amplifier.

Typical Performance for the Servo Linearized DC Amplifier:

- 1% linearity for 10V p-p dynamic range
- Unity voltage gain
- 25 kHz bandwidth (limited by U_1, U_2)
- Gain drift: $-.03\%/^{\circ}C$
- Offset drift: $\pm 1 mV/^{\circ}C$
- Common mode rejection: 46dB at 1 kHz
- 500V DC insulation (3000V if 2 single isolators are used)

DIFFERENTIAL ISOLATION AMPLIFIER

The differential amplifier shown in Figure 4 operates on the principle that an operating region exists where a gain increment in one opto isolator can be approximately balanced by a gain decrement in the second opto isolator. As I_{F1} increases due to changes in V_{IN} , I_{F2} decreases by an equal amount. If $n_1 = n_2 = 2$, then the gain increment caused by increases in I_{F1} will be balanced by the gain decrement caused by decreases in I_{F2} . The constant current source biases each I_F at 3mA quiescent current. R_1 and R_2 are designed so that I_F varies over the range of 2mA to 4mA as V_{IN} varies from -5V to +5V. R_1 and R_2 can be adjusted to accommodate any desired dynamic range. U_3 and U_4 are used as a differential current amplifier:

$$V_{OUT} = R_5 \left[\left(\frac{R_3}{R_4} \right) I_{C1} - I_{C2} \right]$$

R_3, R_4, R_5 have been picked for an amplifier with a gain of 1 for a worst case spread of isolator current transfer ratios. The transfer function of the differential amplifier is:

$$V_{OUT} = R_5 \left[\left(\frac{K_1 R_3}{R_4} \right) \left(\frac{I_{CC}}{2 I_{F1}} \right)^{n_1} \left(1 + \frac{V_{IN}}{R I_{CC}} \right)^{n_1} - K_2 \left(\frac{I_{CC}}{2 I_{F2}} \right)^{n_2} \left(1 - \frac{V_{IN}}{R I_{CC}} \right)^{n_2} \right]$$

if $R = R_1 = R_2$

After zero adjustment, this transfer function reduces to:

$$V_{OUT} = R_5 K' \left[\left(1 + \frac{V_{IN}}{R I_{CC}} \right)^{n_1} - \left(1 - \frac{V_{IN}}{R I_{CC}} \right)^{n_2} \right]$$

$$\text{where } K' = \frac{K_1 R_3}{R_4} \left(\frac{I_{CC}}{2 I_{F1}} \right)^{n_1} = K_2 \left(\frac{I_{CC}}{2 I_{F2}} \right)^{n_2}$$

The non linearities in the transfer function when $n_1 \neq n_2 \neq 2$ can be written as shown below. For example, if $|x| \leq .35$, $n_1 = 1.9$, $n_2 = 1.8$, then the linearity error is 1.5% of the desired signal.

$$\frac{\text{linearity error}}{\text{desired signal}} = \frac{(1+x)^{n_1} - (1-x)^{n_2} - (n_1+n_2)x}{(n_1+n_2)x}, \text{ where } x = \frac{V_{IN}}{R I_{CC}}$$

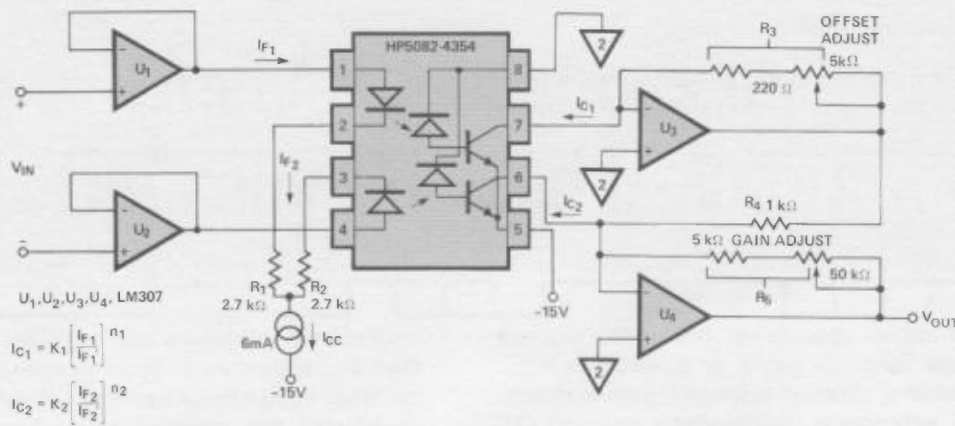

Figure 4. Differential Type DC Isolation Amplifier.

Typical Performance of the Differential Linearized DC Amplifier:

- 3% linearity for 10V p-p dynamic range
- Unity voltage gain
- 25 kHz bandwidth (limited by U₁, U₂, U₃, U₄)
- Gain drift: $-0.4\%/^{\circ}\text{C}$
- Offset drift: $\pm 4\text{mV}/^{\circ}\text{C}$
- Common mode rejection: 70dB at 1 kHz
- 3000V DC insulation

AC COUPLED AMPLIFIER

In an AC circuit, since there is no requirement for a DC reference, a single opto isolator can be utilized by biasing the opto isolator in a region of constant incremental CTR ($\partial I_D / \partial I_F$). An example of this type of circuit is shown in Figure 5. Q₁ is biased by R₁, R₂ and R₃ for a collector quiescent current of 20mA. R₃ is selected so that I_F varies from 15mA to 25mA for V_{IN} of 1V p-p. Under these

operating conditions, the 5082-4351 operates in a region of almost constant incremental CTR. Linearity can be improved at the expense of signal-to-noise ratio by reducing I_F excursions. This can be accomplished by increasing R₃, then adding a resistor from the collector of Q₁ to ground to obtain the desired quiescent I_F of 20mA. Q₂ and Q₃ form a cascade amplifier with feedback applied through R₄ and R₆. R₆ is selected as V_{bc}/I₃ with I₃ selected for maximum gain bandwidth product of Q₃. R₇ is selected to allow maximum excursions of V_{OUT} without clipping. R₅ provides DC bias to Q₃. Closed loop gain ($\Delta V_{OUT} / \Delta V_{IN}$) can be adjusted with R₄. The transfer function of the amplifier is:

$$\frac{V_{OUT}}{V_{IN}} \cong \left(\frac{\partial I_D}{\partial I_F} \right) \left(\frac{1}{R_3} \right) \left(\frac{R_4 R_7}{R_6} \right)$$

Typical Performance of the Wide Bandwidth AC Amplifier:

- 2% linearity over 1V p-p dynamic range
- Unity voltage gain
- 10 MHz bandwidth
- Gain drift: $-0.6\%/^{\circ}\text{C}$
- Common mode rejection: 22dB at 1 MHz
- 3000V DC insulation

DIGITAL ISOLATION TECHNIQUES

Digital conversion techniques can be used to transfer an analog signal between two isolated systems. With these techniques, the analog signal is converted into some digital form and transmitted through the opto isolator. This digital information is then converted back to the analog signal at the output. Since the opto isolator is used only as a switch, the overall circuit linearity is primarily dependent on the accuracy by which the analog signal can be converted into digital form and then back to the analog signal. However, the overall circuit bandwidth is limited by the propagation delays of the opto isolator.

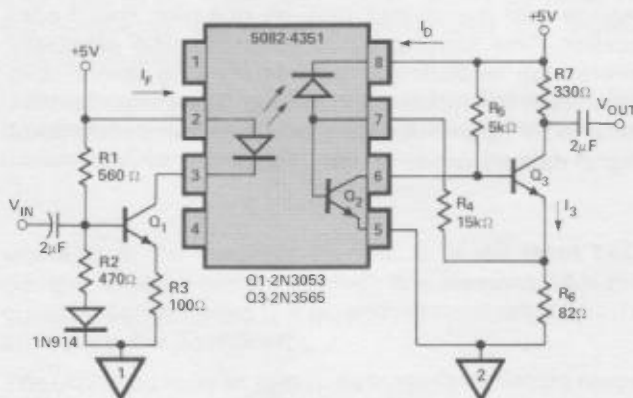

Figure 5. Wide Bandwidth AC Isolation Amplifier.

Figure 6 shows a pulse width modulated scheme to isolate an analog signal. The oscillator operates at a fixed frequency, f , and the monostable multivibrator varies the duty factor of the oscillator proportional to the input signal, V_{IN} . The maximum frequency at which the oscillator can be operated is determined by the required linearity of the circuit and the propagation delay of the opto isolators:

$$(t_{max} - t_{min}) (\text{required linearity}) \geq |t_{PLH} - t_{PHL}|$$

At the output, the pulse width modulated signal is then converted back to the original analog signal. This can be

accomplished with an integrator circuit followed by a low pass filter or through some type of demodulator circuit that gives an output voltage proportional to the duty factor of the oscillator.

Figure 7 shows a voltage to frequency conversion scheme to isolate an analog signal. The voltage to frequency converter gives an output frequency proportional to V_{IN} . The maximum frequency that can be transmitted through the opto isolator is approximately:

$$f_{max} \approx \frac{1}{t}, \text{ where } t = t_{PLH} \text{ or } t_{PHL}, \text{ whichever is larger.}$$

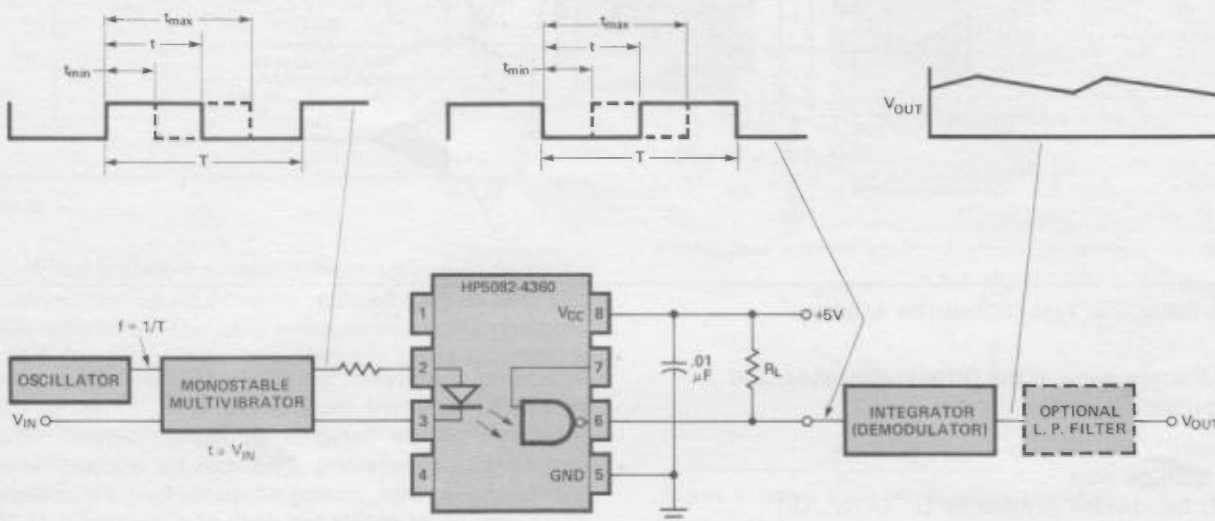

Figure 6. Pulse Width Modulation.

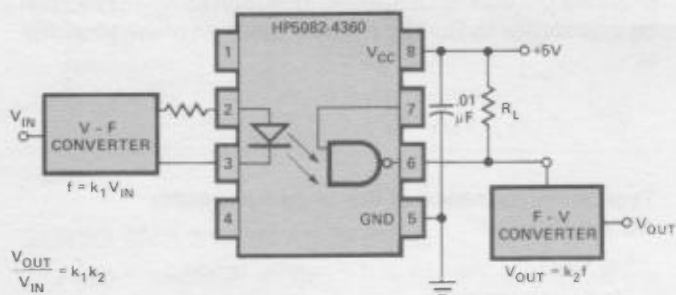

Figure 7. Voltage to Frequency Conversion.

At the output, the frequency is converted back into a voltage. The overall circuit linearity is dependent only on the linearity of the V-F and F-V converters.

Another scheme similar to voltage to frequency conversion is frequency modulation. A carrier frequency, f_c , is modulated by Δf such that $f_c \pm \Delta f$ is proportional to V_{IN} . Then at the output, V_{OUT} is reconstructed with a phase locked loop or similar circuit.

One further scheme to isolate an analog signal is to use A-D and D-A converters and transfer the binary or BCD information through opto isolators. The information can be transmitted through the opto isolators in parallel or serial format depending on the outputs available from the A-D converter. If serial outputs are not available, the A-D outputs can be converted into serial form with a PISO shift register and transmitted through one high speed opto isolator. This scheme becomes economical especially where high resolution is required allowing several opto isolators to be replaced with one high speed opto isolator. Refer to HP Application Note 947 for further discussion of digital data transmission techniques.