

# APPLICATION NOTE 934

## 5082-7300 Series

### Solid State Display

### Installation Techniques

#### INTRODUCTION

The 5082-7300 series Numeric Indicator is an excellent solution to most standard display problems in commercial, industrial and military applications. The unit integrates the display character and associated drive electronics in a single package. This advantage allows for space, pin and labor cost reductions, at the same time improving overall reliability.

The information presented herein describes general methods of incorporating the -7300 into varied applications.

#### DISPLAY MOUNTING

The 5082-7300 and 5082-7302 numeric display modules are designed to be plugged into a DIP connector, or soldered to a PC board. Each display

has 8 leads in a dual line configuration. The lead-to-lead spacing is .100" and the horizontal spacing between lines is .600".

Displays can be end-stacked with .100" spacing between outside pins of adjacent units. This allows the use of the many DIP connectors, designed for MSI - LSI integrated circuits, to mount a cluster of display modules. For example, a 40-pin .600" socket can be used to mount 5 display modules.

Table I lists several commercially available connectors which can be used to mount the -7300 series displays.

The Jermyn series is recommended for applications where the device is to be heat sinked (see below for heat sinking requirements), and when it is desired to end stack connectors. These connectors, how-

| Manufacturer    | Part Number       | Number of Pins | Notes      |
|-----------------|-------------------|----------------|------------|
| Jermyn          | A23-2023Z         | 24             | Solderable |
| Jermyn          | A23-2031Z         | 28             | Solderable |
| Jermyn          | A23-2025Z         | 36             | Solderable |
| Jermyn          | A23-2030Z         | 40             | Solderable |
| Cambion         | 703-3790-01-04-16 | 24             | Solderable |
| Cambion         | 703-3896-01-01-16 | 24             | Wire Wrap  |
| Cambion         | 703-3791-01-04-16 | 36             | Solderable |
| Cambion         | 703-3893-01-03-16 | 36             | Wire Wrap  |
| Augut           | 324-AG2D          | 24             | Wire Wrap  |
| Augut           | 336-AD2D          | 36             | Solderable |
| Robinson-Nugent | IC-246            | 24             | Solderable |
| Robinson-Nugent | IC-366            | 36             | Solderable |

Table I

ever, should be soldered into a PC board or used in a similar pin restraining application. Multiple insertions into these connectors tends to push the connecting clip out of the plastic housing. 8N connector pins are required for N digits in a cluster. The Jermyn connectors can be end stacked with a typical .050" additional pin-to-pin interstitial space. Figure 1 shows a typical mounting configuration using these connectors:

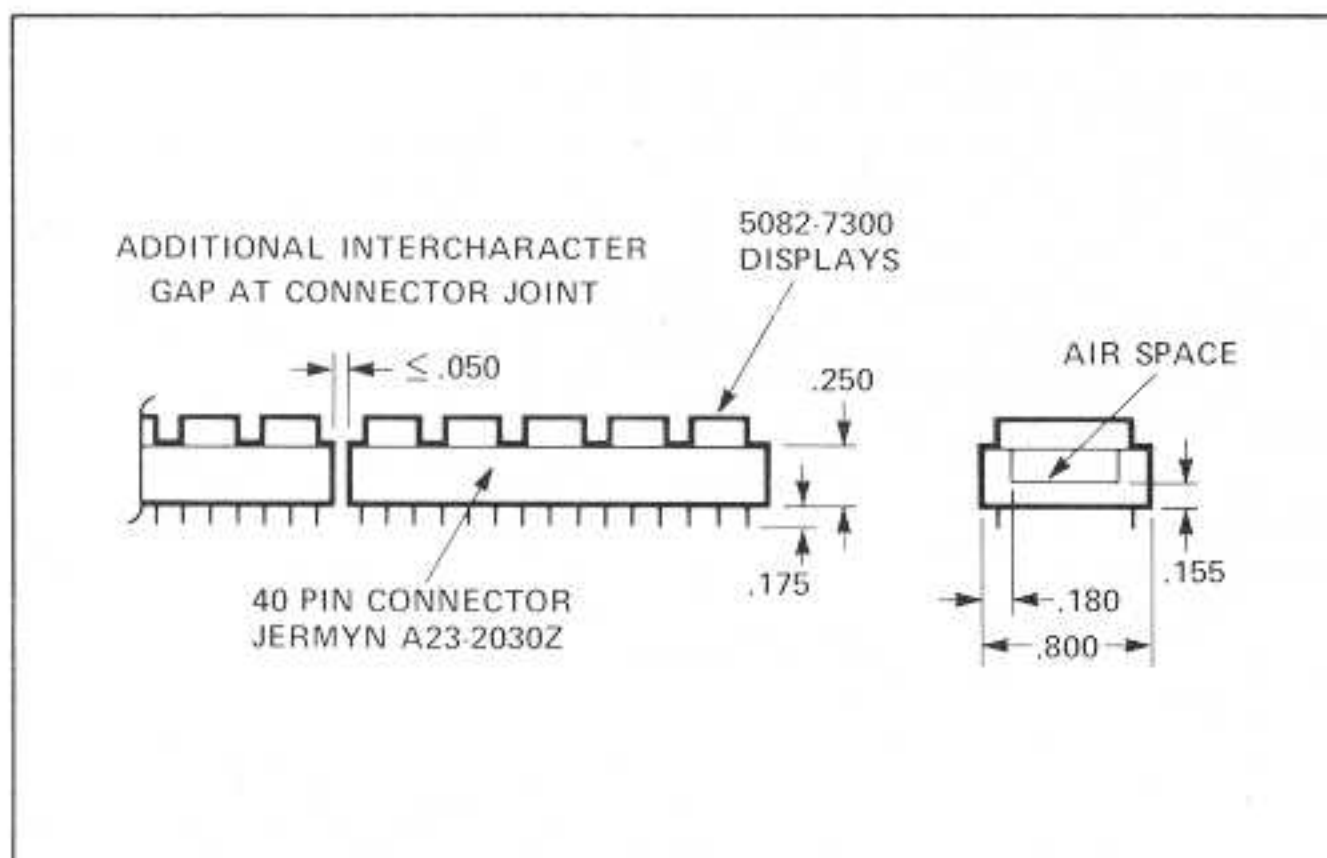

Figure 1. Typical Connector Mounted Array of Display Modules

The Jermyn connectors also provide a space between the back of the display module and the plastic connector housing. When left unfilled, this space allows for air circulation to improve heat transfer by convection and radiation. Heat sinking material can also be placed in this gap.

### PC BOARD MOUNTING

The 5082-7300/7302 can be soldered into a PC board at a maximum solder temperature of 230°C for 5 seconds. The DIP leads on the display package have ears which provide an insertion stop. Displays soldered into PC board holes 0.020" in diameter will have a nominal .080" space between the PC board and the back of the device. This space allows for air circulation. As with the connector mounted case, this space can be filled with heat sinking material if required.

### HEAT SINKING

The 5082-7300/7302 are designed to operate with a maximum case temperature of 85°C, as measured at the metallized back plane of the unit. Maintaining this temperature limit on the back metal plane or case will assure that the internal display temperature is within design limits. Case temperature can be measured with a small thermocouple connected to the case with thermally conductive compound.

When mounted in either a double DIP socketed or soldered to a PC board, heat conduction through the display leads is typically adequate to maintain the case temperature to within 20°C of ambient.

Thus, in typical applications, the devices can be operated to an ambient of 65°C without external heat sinking.

In applications where the ambient temperature exceeds 65°C additional heat sinking is required. This can be achieved by use of a metallic strap normally mounted horizontally to the back plane of the display modules and the PC board or DIP socket. In addition, to assure a uniform thermal path between the display and the metal strap, a thermally conductive compound, such as Wakefield 120, or Dow Corning 340 should be used at this interface.

### OPTICAL CONSIDERATIONS

The 5082-7300/7302 display modules are encapsulated with a contrast enhancing red filter. When the long wave filter is cascaded with the spectral response of the eye, the composite response is that of a pass band filter, centered at approximately the peak of the light emitting diode spectrum. The filter enhances contrast by absorbing ambient light which impinges on the front surface of the display module. If additional filtering is desired, the use of Plexiglass #2423 is recommended.

This inexpensive material offers contrast ratios in excess of 30/1, yet has transmissivity of 70% or better for the light emanated from the display. Another filtering material is Polaroid HRC-7, which combines a long wave pass filter like the Plexiglass, with a section of circularly polarized filtering material. Such a filter offers contrast ratios in excess of 100/1, but suffers from a transmissivity of only about 35% for the LED light. For reference, contrast ratio is defined as

$$C = \frac{S - N}{N}$$

where S is the luminance of the display elements, and N is the luminance of the background.

### ELECTRICAL INTERFACE

The 5082-7300/7302 displays are fully DTL-TTL compatible. Each display decoder/driver includes a quad latch capable of storing 4 line BCD input data. Utilizing the storage capability, the device will continue to display data after it is no longer available to the input.

The device can also be used as a "real time" display (output at any time - only a function of the input at that time), by holding the enable line in the logic low state. Wiring pin 5 to ground potential is a convenient method of using the devices as real time displays.

When the latch feature is used, data should be available to the input 50 ns or more before the enable rises to a Logic "1" level, and it should be held for 50 ns or more after the enable rises to

ensure reliable operation. The BCD inputs are positive logic and the decimal point convention is active low.

Unused inputs may be left open or tied to  $V_{CC}$  through a resistor.

The displays can be used with multi-digit data available in either bit parallel, character parallel or bit parallel, character serial format as illustrated in Figures 2 and 3 respectively. The 50 ns setup time and 50 ns hold time allows the data to be clocked into an array of displays at 10 MHz.

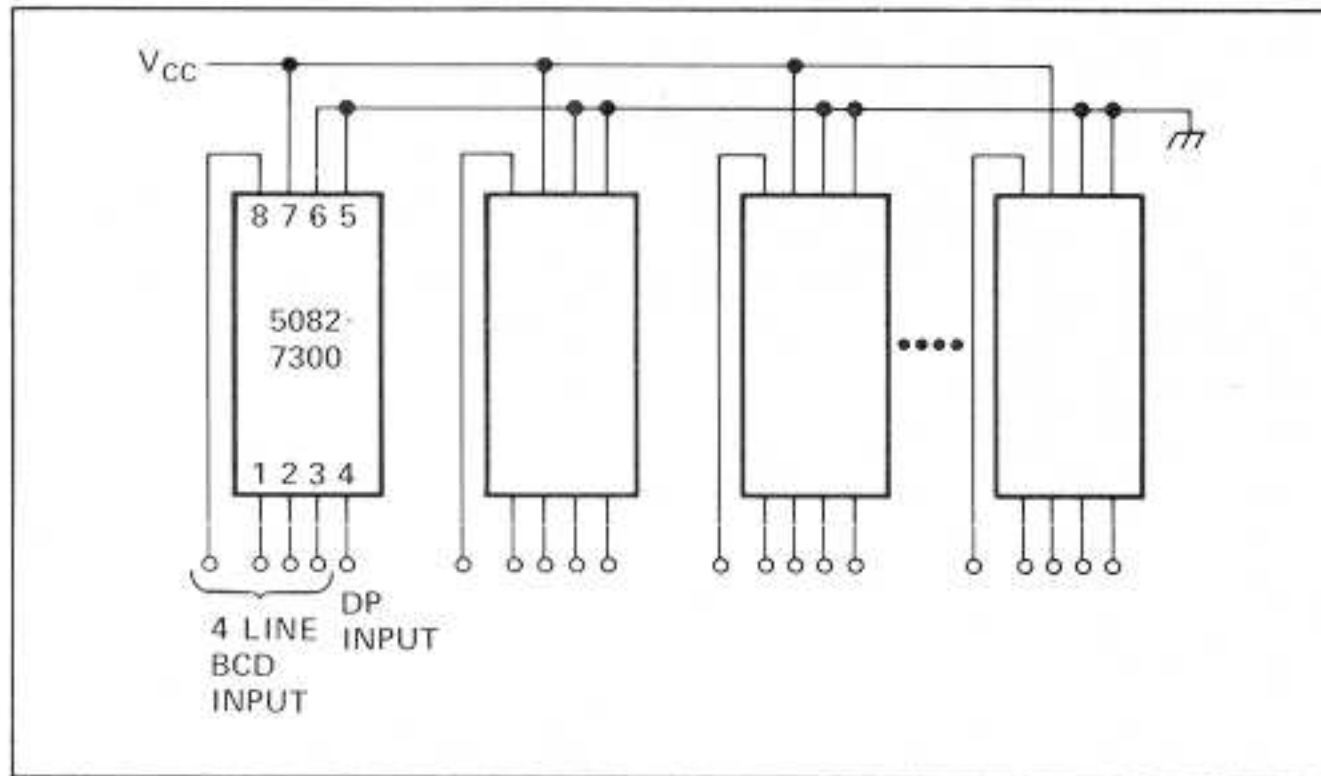

Figure 2. Bit Parallel, Character Parallel Wiring Configuration

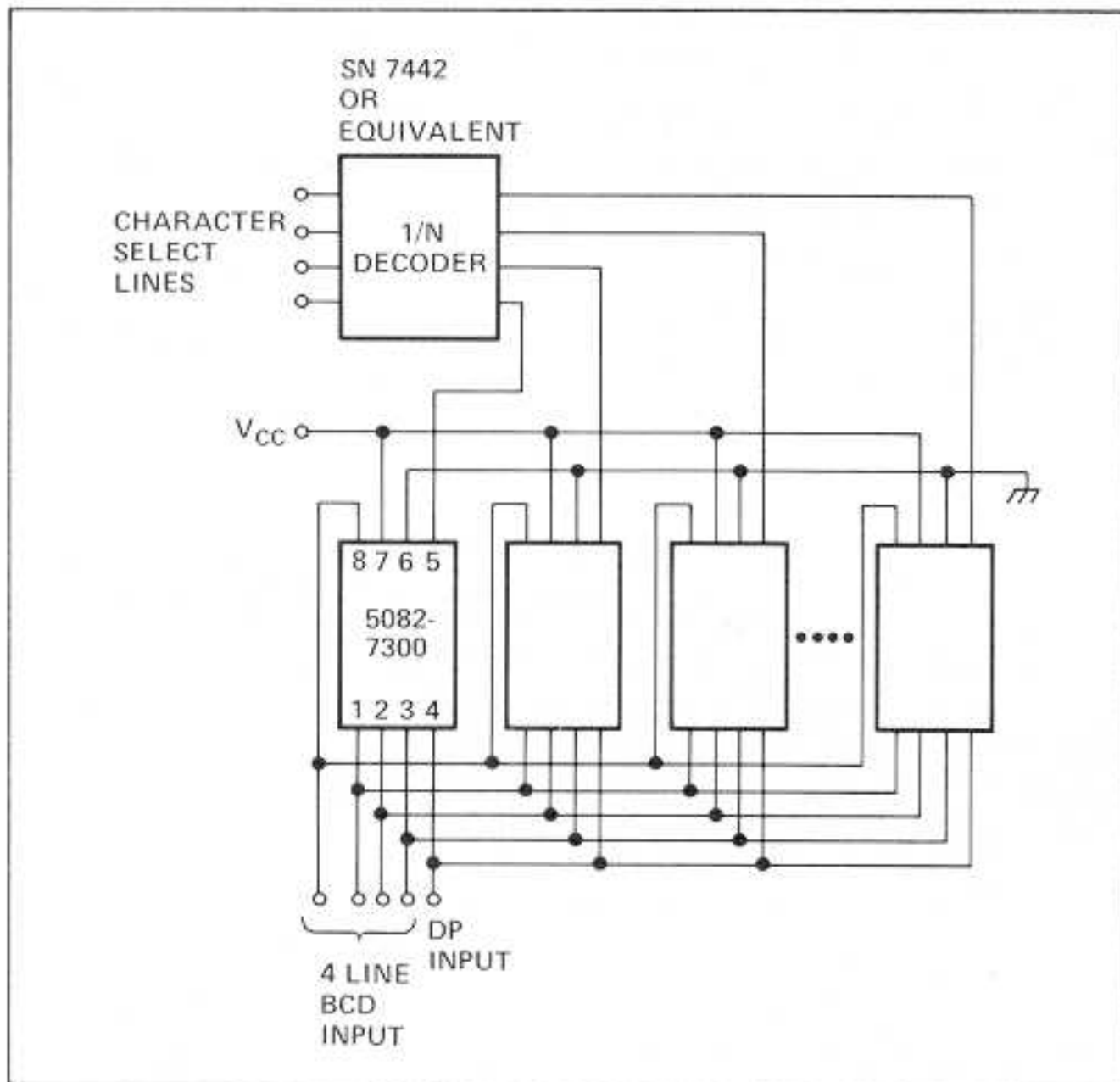

Figure 3. Bit Parallel, Character Serial Wiring Configuration

## BLANKING THE DISPLAY FOR BRIGHTNESS CONTROL

The 5082-7300/7302 display modules can be blanked in one of two ways:

- 1) Applying one of the 4 BCD combinations which result in a blanked display.
- 2) Removing  $V_{CC}$  from the display module to be blanked.

Repetitive duty factor blanking by either method can be used to decrease the apparent brightness of the display. If pulse width modulation is applied at a repetition rate of 100 Hz or faster, the display will appear flicker free. This PWM technique can be used to control brightness over several orders of magnitude. Both brightness control and blanking techniques involve loss of information stored in the latches during the blanking phase. Method one can be accomplished with 3 dual input OR gates per display as shown in Figure 4.

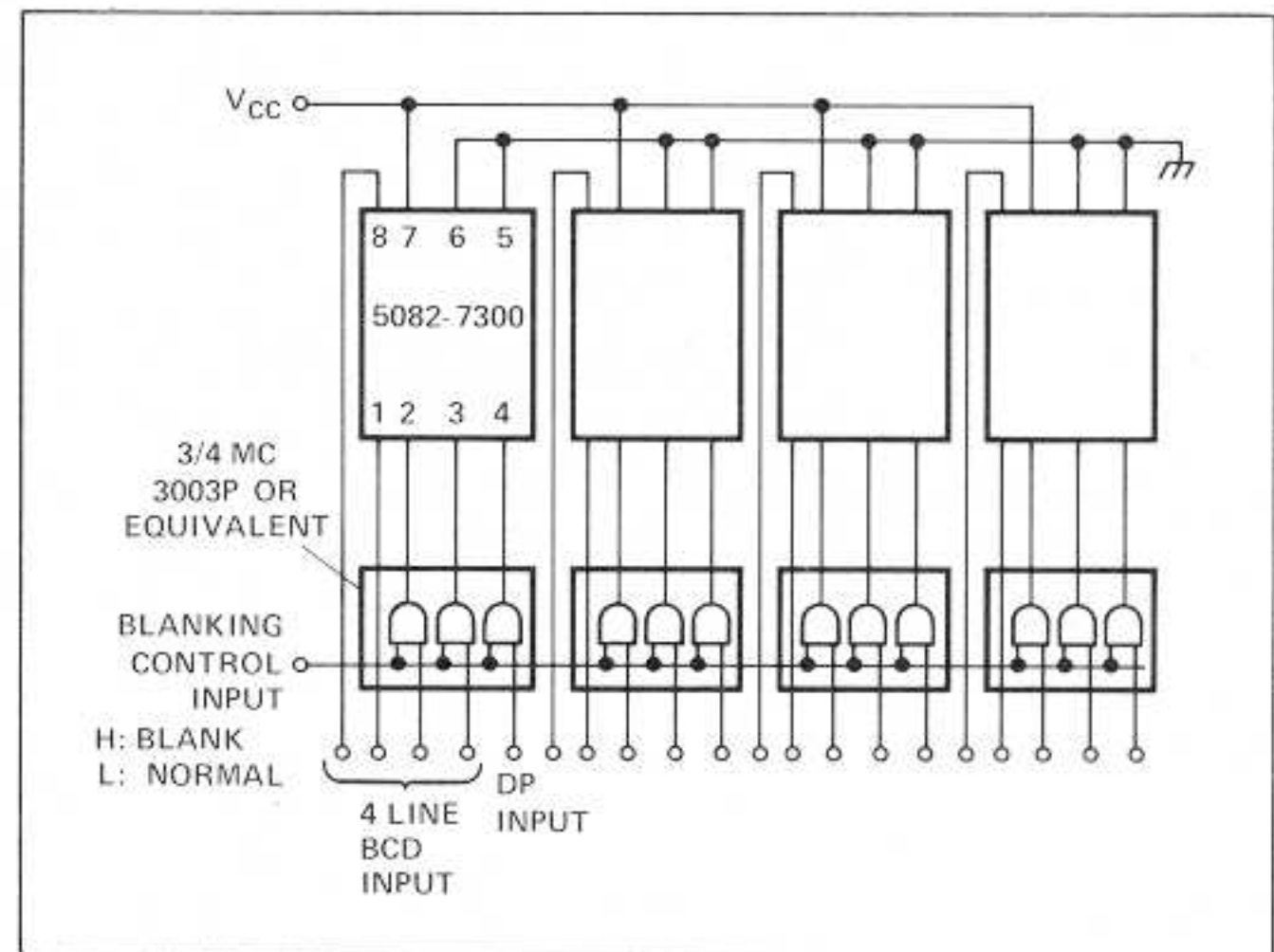

Figure 4. Bit Parallel, Character Parallel Blanking Scheme

The  $I_{CC}$  current drawn by a 5082-7300/7302 display module when blanked by this method is approximately 45 mA.

An alternative to method 1 utilizes the uncommitted feature of "tri-state" logic. Figure 5 illustrates the use of tri-state decade counters with the 5082-7300/7302 displays.

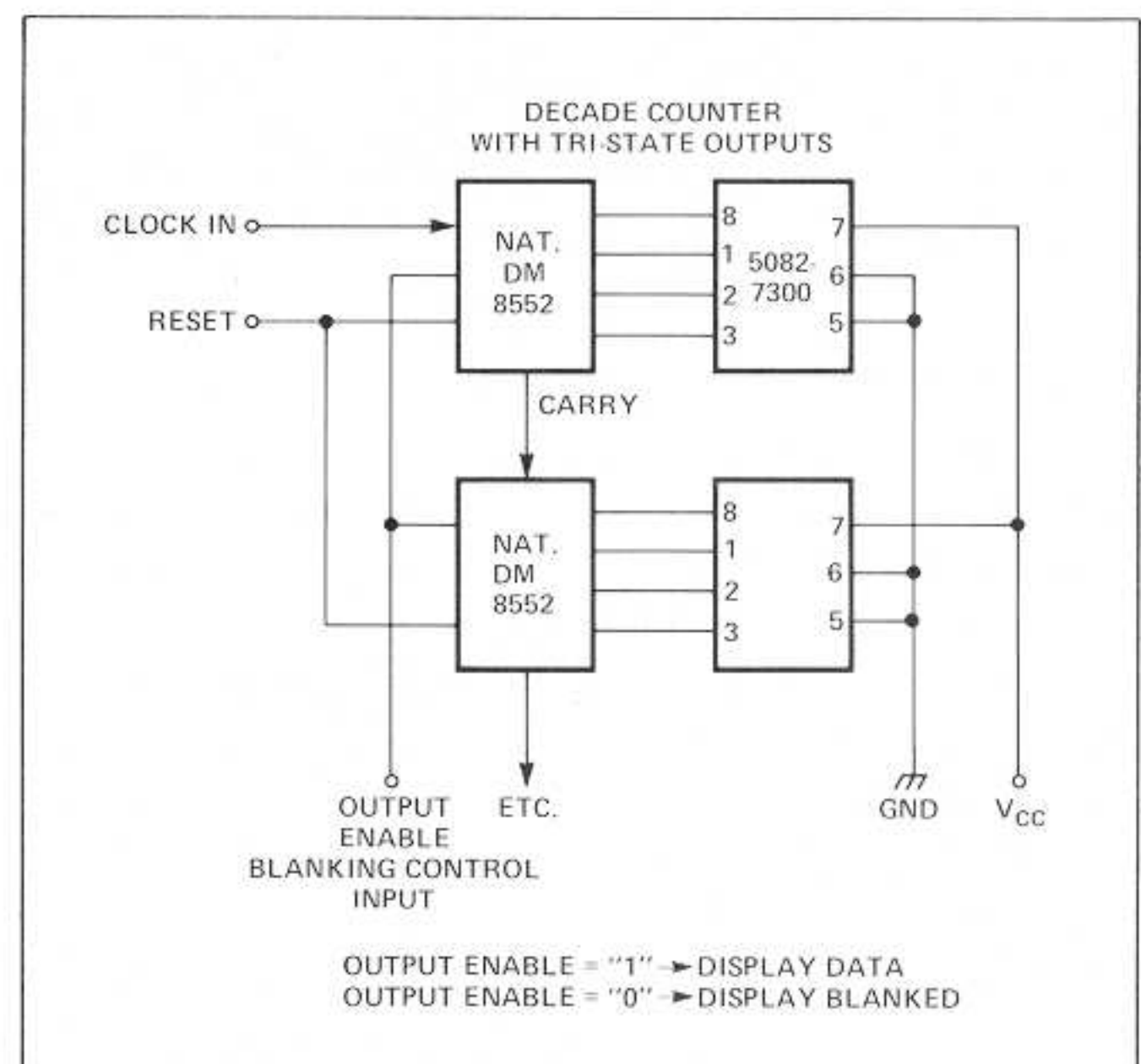

Figure 5. Blanking Scheme Example Using "Tri-State" Output Devices

When the outputs are "disabled", the BCD inputs to the display are effectively in the logic "1" state, since no current can flow out of input terminals. Method 2 can be implemented as shown in Figure 6 by placing a switching transistor in the  $V_{CC}$  line. A cluster of display modules can be switched with one transistor. The transistor and power supply voltage should be chosen to keep the  $V_{CC}$  pin potential within the recommended range (4.5 to 5.5V).

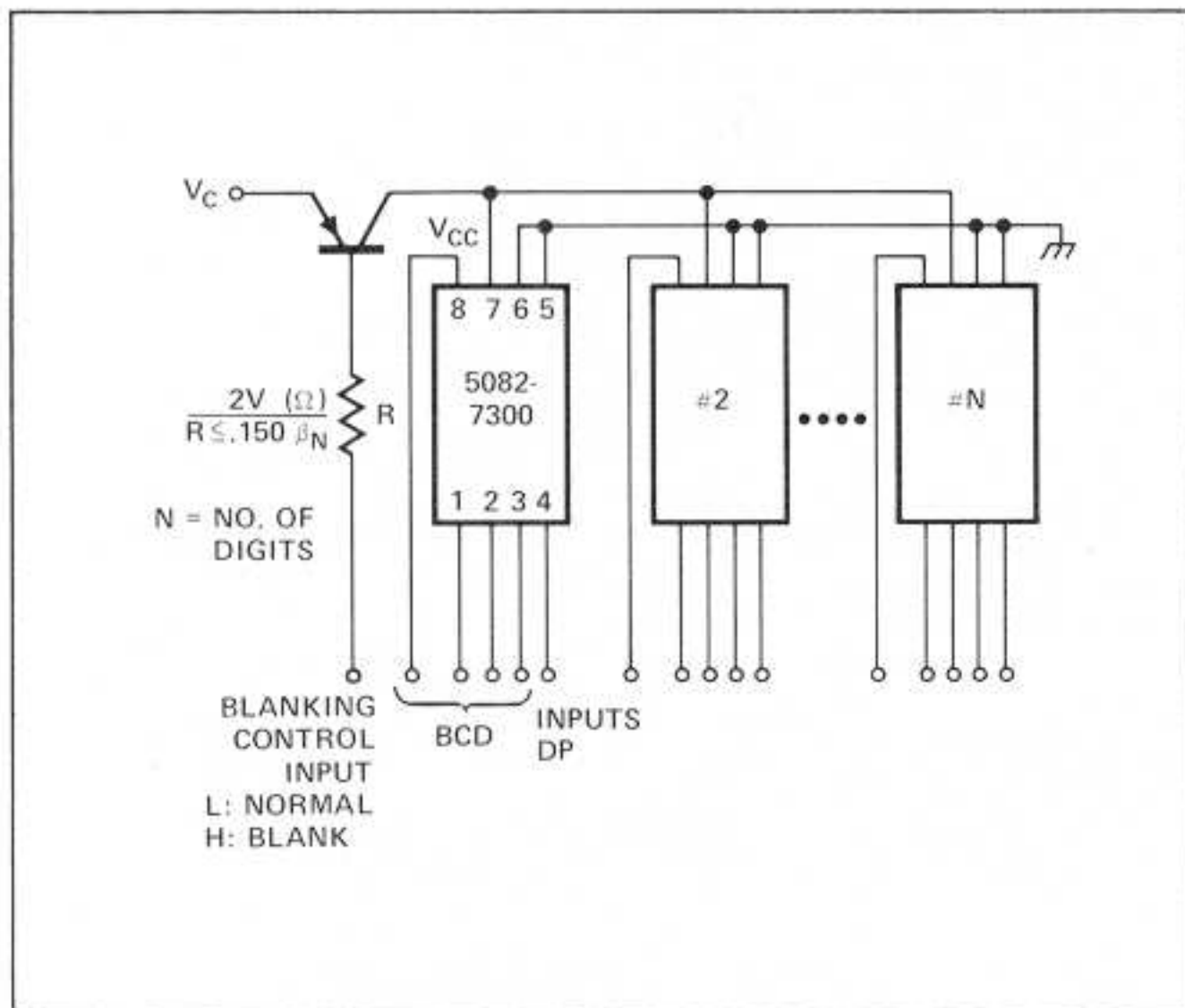

Figure 6. Blanking Using  $V_{CC}$  Line Switching

If this method is used, it is important that the  $V_{CC}$  pin not be connected to ground through a low resistance when any of the input lines (BCD, decimal point, enable) are held at a high voltage. This method allows power saving for low levels of brightness, since no power is dissipated in the display modules when the device is in the "blanked" mode.

Any of these blanking schemes can be used with a pulse width modulation circuit of the type shown in Figure 7 for brightness control such as the one shown.

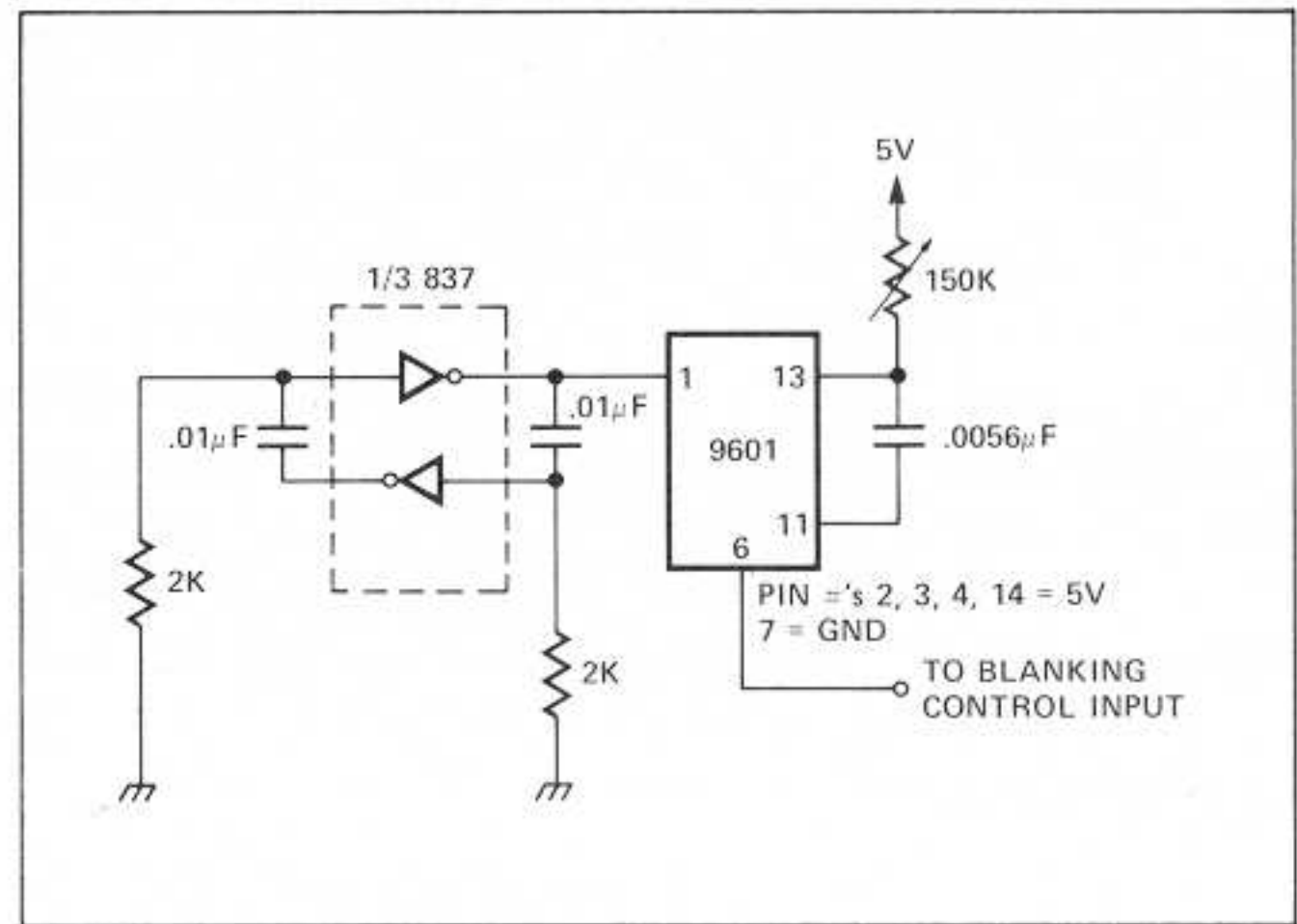

Figure 7. PWM Brightness Control Circuit

### ACTIVATING THE DECIMAL POINT

The decimal point convention is "active low", i.e., low logic level corresponds to decimal point on. Hence, in normal applications, the probability of a decimal point being on is less than .5, this convention minimizes leakage current. In addition, the convention allows the decimal point pin to be left open when not used, and also allows use of an active low 1/N decoder as described in Figure 8 to select the appropriate decimal point in "floating decimal point" applications.

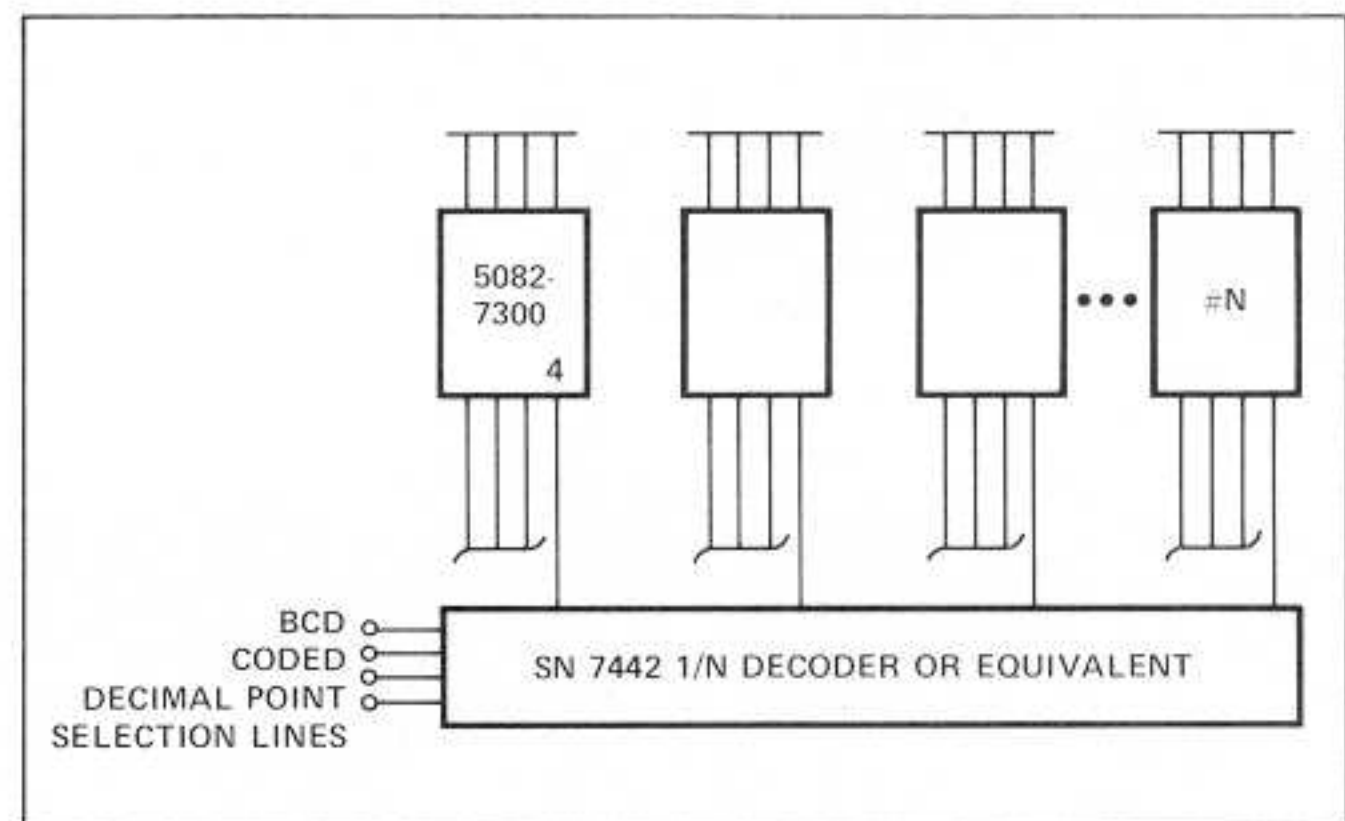

Figure 8. Activating Decimal Points with A 1/N Decoder

For more information, call your local HP Sales Office or East (201) 265-5000 • Midwest (312) 677-0400 • South (404) 436-6181 West (213) 877-1282. Or, write: Hewlett-Packard, 1501 Page Mill Road, Palo Alto, California 94304. In Europe, 1217 Meyrin-Geneva

HEWLETT  PACKARD  
COMPONENTS