



**AN 932**

**Selection  
and use of  
Microwave  
Diode Switches  
and Limiters**

HEWLETT  PACKARD

# Application Note 932

## Selection and Use of Microwave Diode Switches and Limiters

### CONTENTS

|  | Page No. |
|--|----------|
| I. Introduction . . . . .  | 1        |
| II. Diode Control Products – A General Discussion . . . . .                                      | 1        |
| III. Choosing Switches and Limiters . . . . .  | 6        |
| IV. Operating Characteristics and Important Parameters<br>of SPST Switches and Modules . . . . . | 9        |
| V. Operating Characteristics and Important Parameters<br>of SPDT Switches . . . . .              | 21       |
| VI. Operating Characteristics and Important Parameters<br>of Limiters . . . . .                  | 23       |
| VII. Using Modules . . . . .   | 25       |
| VIII. Switching Circuits . . . . .   | 29       |
| IX. Measuring Switches and Limiters . . . . .  | 33       |

## I. INTRODUCTION

The purpose of this application note is to help the systems designer select the proper switching or limiting component and to assist him in integrating this component into the overall design of the system. Much of this material is based upon questions and inputs received from HP's customers over a period of several years. The intent is to present a practical, user-oriented approach to problems encountered with switching and limiting microwave signals; a rigorous analysis is not attempted.

## II. DIODE CONTROL PRODUCTS – A GENERAL DISCUSSION

### A. Microwave Diode Switches

Components used for control of microwave signals fall into one of three categories — diode, ferrite, or electromechanical. The characteristics of the three types are sufficiently dissimilar that most applications dictate a single approach. In some sys-

tems, however, the designer does have a choice. The important characteristics of the three types are compared in Table 1.

Most of the microwave signal control functions in modern systems are achieved with diodes. The basic technique is simple. One or more diodes are incorporated into a transmission line as series or shunt (or both) elements. The RF resistance of the diodes can be varied by the application of steady state or time varying bias, and the microwave signal is controlled (i.e., passed, rejected, attenuated, or modulated) according to the bias applied.

### B. The PIN Diode

Before discussing the specific circuits, consideration must be given to the characteristics of the diode. The ideal switching diode would look something like this:

- It would look like a perfect resistor under all conditions of bias.
- Its resistance would vary from zero to infinity.

Table 1. A Comparison of Diode, Ferrite, and Electromechanical Switches.

| CHARACTERISTIC                          | DIODE SWITCHES           | FERRITE SWITCHES                                      | ELECTROMECHANICAL SWITCHES                       |
|---|--------------------------|---|--|
| Switching speed                         | Nanoseconds              | Microseconds (low field)<br>Milliseconds (high field) | Milliseconds                                     |
| Insertion loss                          | Higher                   | Low   | Low  |
| Isolation                               | Typ to 80 dB             | Typ 20 dB (low field)<br>Typ 60 dB (high field)       | Typ 60 dB  |
| Can be used for analog applications     | Yes                      | Yes   | No   |
| Lifetime (cycles)                       | Unlimited                | Unlimited   | Several million cycles for best quality switches |
| Size & weight                           | Least                    | Greater   | Greater  |
| Ability to withstand severe environment | Best                     | Temperature sensitive                                 | Temperature, vibration, and shock sensitive      |
| Bandwidth                               | Octaves to multi-decades | Octaves or less                                       | Dc to 18 GHz                                     |

- The resistance vs. bias characteristic would be linear, require low current, and be reproducible from diode to diode.
- It would be rugged, capable of handling high power and withstanding severe environments.
- It would not rectify RF energy, yet it could be switched rapidly and would have a high modulation bandwidth.

Although it isn't "ideal," the PIN diode exhibits all of these characteristics to some degree. A PIN diode is a silicon semiconductor consisting of a layer of intrinsic material contained between highly doped P and N material. When the diode is forward biased, charge is injected into this "I layer." The conductivity of the diode is proportional to this stored charge, which in turn is proportional to the dc bias current.

An important parameter of the PIN diode is the lifetime (denoted by  $\tau$ ). This defines the length of time it takes, once the forward bias is removed,

for the stored charge to deplete by recombination. The range of  $\tau$  found in PIN diodes varies from less than 1 nanosecond to several microseconds.  $\tau$ , and its related parameter  $f_O$  ( $f_O = \frac{1}{2\pi\tau}$ ), determine how the diode reacts to frequency, as follows:

1. At frequencies below  $f_O$ , the relationship of stored charge to ac bias is the same as the relationship to dc bias.
2. At  $f_O$ , the response to ac bias begins to drop off at a rate of about 6 dB per octave, as shown in Figure 1.
3. At frequencies well above  $f_O$ , the response to ac bias is negligible, and the diode simply behaves like a resistor.

Consider the shunt diode switch circuit shown in Figure 2. If this circuit is placed between an RF generator and a load, and if the RF frequency is well above  $f_O$ , the RF will pass with very little attenuation, since the unbiased PIN diode will exhibit an RF resistance of several thousand ohms.

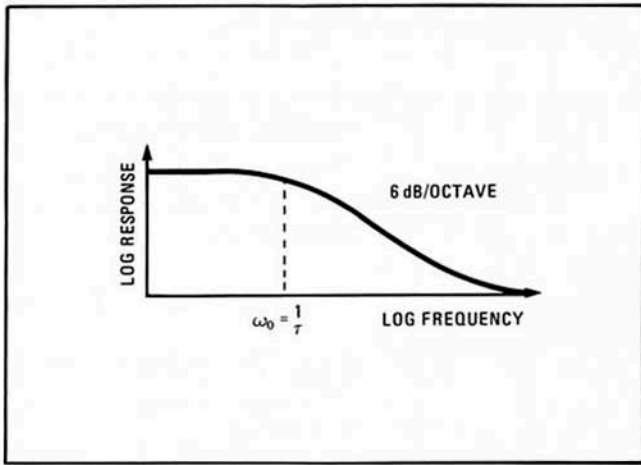

Figure 1. PIN Behavior as a Function of Frequency.

If a forward dc bias is now introduced to the switch, the RF resistance of the diode will be reduced in proportion to the bias current, and the RF signal will be attenuated. This attenuation will be partly due to reflection, caused by the resistive mismatch, and partly due to the power that is absorbed in the diode.

If we now superimpose on the dc bias an ac signal whose frequency is below  $f_0$ , the attenuation will vary according to this ac signal. The RF will therefore be AM modulated at a rate corresponding to the ac signal. If we increase the frequency of the ac signal above  $f_0$ , the modulation index will drop off at about 6 dB per octave, assuming the amplitude of the modulating signal remains constant.

So far, we've assumed that the RF frequency is well above  $f_0$ . If this frequency is now reduced to a few octaves above  $f_0$ , the diode starts to respond to the RF. This results in distortion of the RF signal, and if the RF level is high enough, the attenuation level, as set by the dc bias, is considerably changed. We can correctly assume that PIN diodes whose  $f_0$  is not well below the RF frequency are not applicable for analog (i.e., variable attenuator or modulator) applications, unless the RF power is fairly low (<0 dBm).

Digital (i.e., switching) applications are not governed by this restriction. In this type of application it is normal to have saturated forward bias and saturated reverse bias conditions, and to switch from one state to the other as rapidly as possible. Even though the relationship between  $f_0$  and the RF frequency may be such that the diode readily responds to the RF, when biased into saturation it will not respond to any ac modulation. The only negative

effect is a short period during the switching time when distortion of the RF may take place.

The switching speed of a PIN diode is a function of  $\tau$ . For fast switching, preemphasis is used. A pulse whose initial amplitude is well in excess of saturation and whose rise time is much shorter than  $\tau$  will result in switching times on the order of 10% of  $\tau$ .

### C. Basic Switching Circuits

The basic diode switch circuits are shown in Figures 2 and 3. The shunt diode switch is ON\* when the diode is zero or reverse biased, and it is OFF when the diode is forward biased. Just the opposite is true with the series diode switch: zero or reverse bias turns the switch OFF, and forward bias turns it ON.

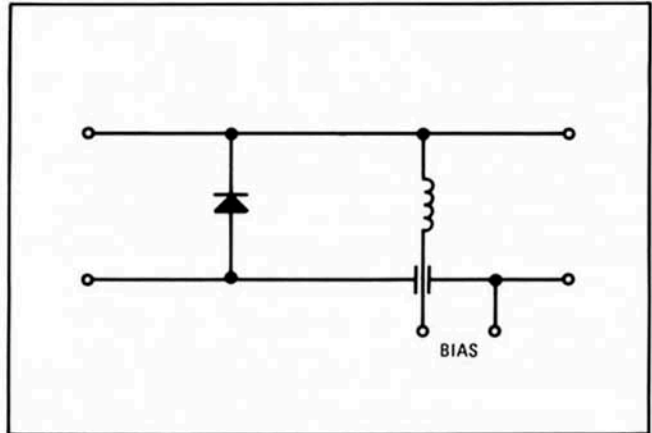

Figure 2. Shunt Diode Switch Circuit.

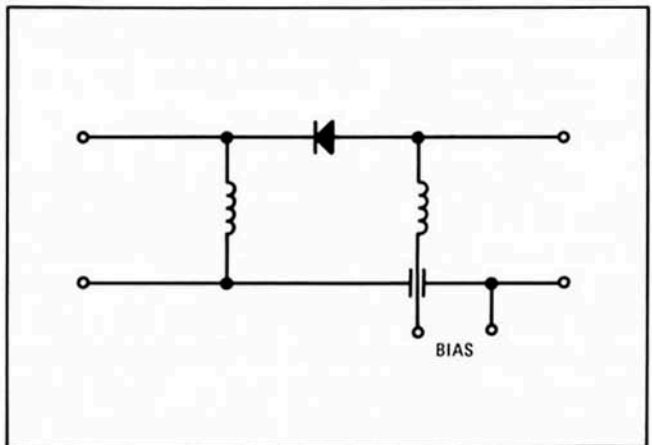

Figure 3. Series Diode Switch Circuit.

\*ON and OFF refer to the RF. The switch is ON when the RF is passing through with minimum attenuation; it is OFF when the attenuation is raised above the minimum point. ON and OFF specifically DO NOT refer to the diode bias.

At microwave frequencies we must also consider the effects of parasitic reactances. If packaged diodes are used, the package reactances (series inductance and shunt capacitance) are of sufficient magnitude to require matching, which results in a narrow band switch. The HP control products integrate diode chips directly onto the transmission line, leaving only one reactance to contend with — that of the diode junction capacitance ( $C_j$ ). This capacitance appears across the I layer and is significant only when the diode is zero or reverse biased, since it is shunted by a low value of resistance when the diode is forward biased. The effect of this reactance depends upon the circuit.

In the shunt circuit, the ON condition is affected, since this is the condition in which the diode is zero or reverse biased. As frequency increases, the capacitive susceptance of the diode increases until the resulting reflections (or associated insertion loss) rise to unacceptable levels.

The OFF condition is affected in the series switch. Increasing frequency means that more signal leaks through the increasing capacitive reactance, thereby decreasing isolation.

In practical terms, the degradation of OFF condition isolation of series diode switches happens at a much lower frequency than the corresponding degradation of ON condition insertion loss of shunt diode switches. For example, using a typical value of 0.1 pF, series switches exhibit significant isolation rolloff above 1 GHz, whereas the insertion loss of a shunt switch will not be affected below 10 GHz; using simple low pass filter techniques, the passband can be increased to above 18 GHz. As a result, series diode SPST switches are seldom used above 1 GHz.

More than one diode can be used to increase isolation. This applies to multiple series diodes, multiple shunt diodes, or a combination of series and shunt diodes. The latter is seldom used for SPST switches but serves a useful function in broadband multithrow switches, as will be shown later.

Since the diodes are reflective elements, the isolation resulting from the use of multiple diodes varies according to the electrical length between them. As a rule of thumb, if the spacing between the diodes is near  $0^\circ$  (or multiples of  $180^\circ$ ) the isolation increases about 6 dB each time the number of diodes is doubled. For spacing near  $90^\circ$  (or odd

multiples thereof), the total isolation (in dB) is the sum of the isolation (in dB) of each diode plus about 6 dB for each additional diode.\*

#### D. Absorptive Switches

The circuits discussed so far are reflective switches; when biased for maximum attenuation they reflect almost all of the incident RF power back to the generator. Many systems will not tolerate mismatches and therefore require absorptive, rather than reflective, switches. There are several ways to build absorptive control circuits using PIN diodes, but such circuits generally exhibit isolation/insertion loss ratios which are inferior to those achieved using reflective switches, particularly at higher frequencies.

We can, however, combine reflective switches with other circuit elements to get good performance and at the same time present a good match to the input and/or output over all bias conditions. Figure 4 shows two methods used to make absorptive switches. The circuit that uses circulators presents the lowest insertion loss, but it is typically limited to one octave (or less if the ambient temperature range is broad). The circuit that uses hybrids typically spans two octaves, with less temperature sensitivity; the insertion loss is higher, however.

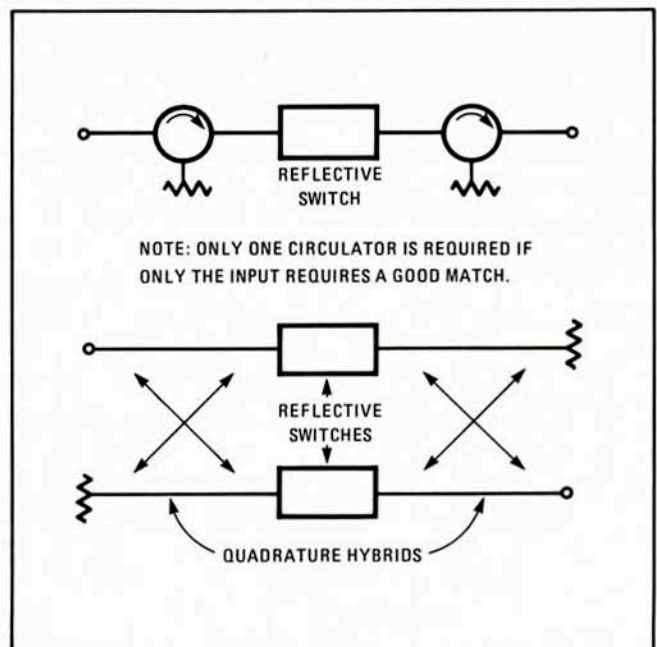

Figure 4. Absorptive Switches.

\*Example: If the isolation afforded by a single diode is 20 dB, two diodes will give 26 dB when  $\beta\ell = 0^\circ$  and 46 dB when  $\beta\ell = 90^\circ$ ; four diodes will give 32 dB and 98 dB respectively.

## E. Multithrow Switches

So far we have discussed only single-throw switches, but multithrow switches can also be built with PIN diodes, either by using the diodes as basic components or by combining SPST switches with other circuit elements. Figure 5 shows the three basic circuits for single pole multithrow switches; for simplicity, only SPDT circuits are illustrated, but the basic techniques can be used to build switches with more than two throws.

The series multithrow circuit also suffers from rolloff of isolation at microwave frequencies. For this reason, this circuit is seldom used above 1 GHz.

The shunt multithrow circuit affords excellent performance, but because it relies on electrical length it is bandwidth-limited. Using a single quarter wavelength spacing, this type of switch can be well matched over more than an octave by using compensation (the technique is described in Section VIII-A). However, it is difficult to keep the spacing down to a single quarter wavelength at higher frequencies.

The series-shunt circuit gives both wide bandwidth (from the series diodes) and high isolation across the microwave spectrum (from the shunt diodes). The only significant tradeoff involves switching speed — this particular circuit will not allow the diodes to switch as fast as they will in a simple circuit. There are techniques to enhance switching speed; they are discussed in Section V-B.

## F. Microwave Diode Limiters

There are a number of microwave systems containing sensitive amplifiers, mixers, detectors, samplers, and the like that operate in environments which may expose these components to burnout level microwave power. One example is a spectrum analyzer which may be overloaded due to careless handling; another may occur when two radar systems are in close proximity (for example, at a crowded airport) and the transmitter of one damages the receiver of the other. Protection for these systems can be provided by a limiter.

The two basic approaches to limiting are feedback systems and passive limiters. A feedback system is a standard ALC loop. Some portion of the input signal is detected and fed into the input of an amplifier which drives a PIN diode switch. If fast rise time pulses are to be limited, the delay through the amplifier and the switch circuitry must be considered, and if necessary an RF delay line must be inserted between the detector takeoff and the switch.

In a passive limiter the same element detects the RF power and causes limiting. The three types of passive limiters commonly used are gas tubes, ferrite limiters, and diode limiters. The first two types handle very high power (gas tubes can withstand multimewatt pulses) and are very slow (in the microsecond region). Diode limiters, on the other hand, deal with low power (typically 100 watts peak) and switch in a few nanoseconds.

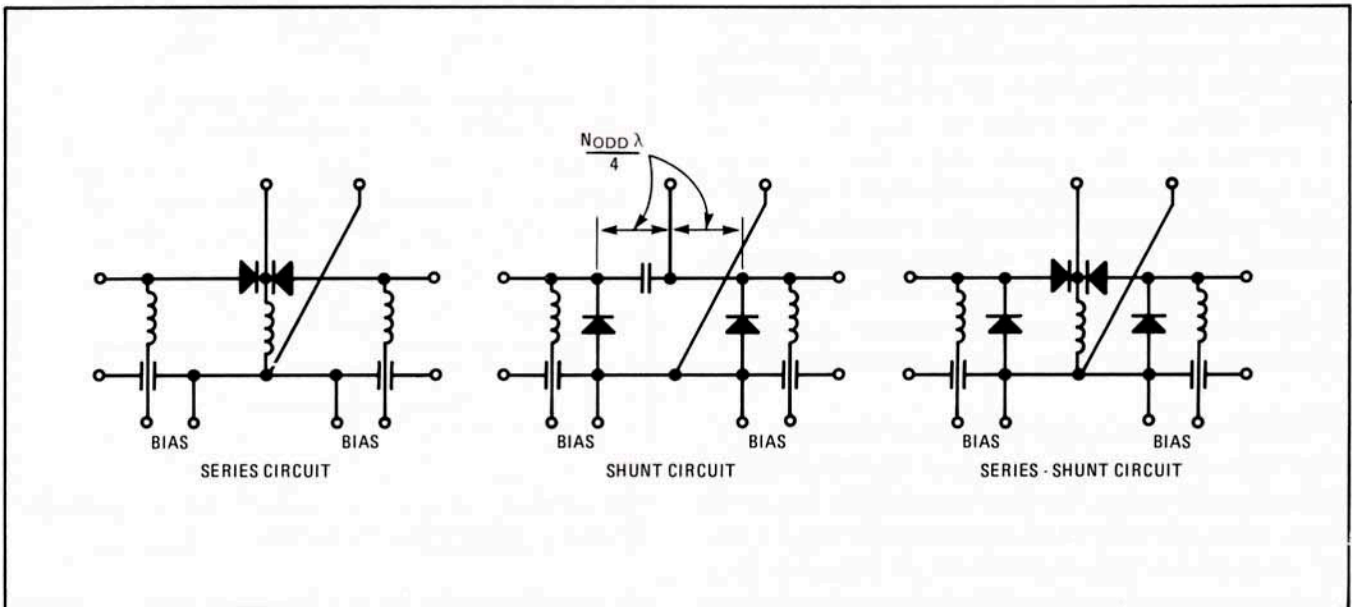

Figure 5. SPDT Circuits.

A diode limiter is a microwave switch that relies upon self bias rather than externally applied bias. The diodes used are PIN diodes with very short lifetimes (typically less than 1 ns ) that will efficiently rectify the RF power when it exceeds a given level. All microwave diode limiters use shunt diodes, because the presence of excess power (and therefore bias) should shut the limiter OFF.

A typical limiter circuit is shown in Figure 6, and a curve of limiting characteristics is shown in Figure 7. The action of a limiter is best understood if we consider the ideal limiter diode, which is a perfect semiconductor junction (infinite resistance reverse, zero resistance forward) with a small series junction voltage. If the  $\tau$  of the diode is such that it will rectify the incident RF, it will do so only if the RF voltage is greater than the junction voltage. Below that level (or threshold\*) the diode appears as an infinite resistance. Above this threshold the diode resistance is zero, and whatever current is necessary to keep the RF output at a fixed level will flow.

As Figure 7 shows, the practical limiter deviates from the ideal curve because the transition from high to low resistance is not abrupt, the diode resistance does not go to zero, and at a high enough power level the limiter goes into saturation.

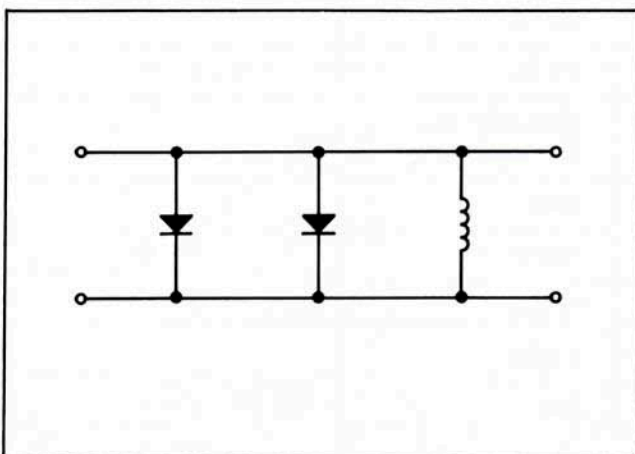

Figure 6. Limiter Circuit.

\*The practical definition of limiting threshold is that power level at which the isolation of the limiter is 0.3 dB greater than the insertion loss at lower levels.

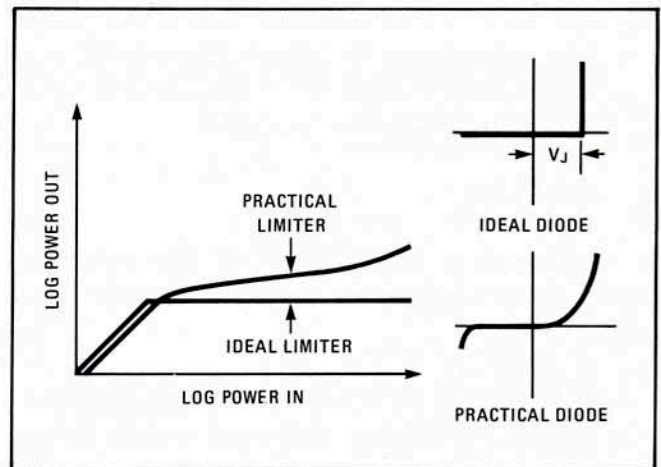

Figure 7. Limiter Characteristics.

### III. CHOOSING SWITCHES AND LIMITERS

#### A. Some Available Choices

Because of the wide variety of diode control components available to the system designer, it is often difficult to select the optimum switch or limiter for a given application. However, there are a few basic considerations which constitute the bulk of the decision:

- *The basic circuit.* As previously discussed, the diode circuit (i.e., shunt, series, or series-shunt) is usually dictated by the frequency. However, diode switches are often combined with other components to form control circuits. This is discussed in Section VIII.
- *The number and type of diodes.* Several diodes can be combined to give high values of isolation, with some tradeoff of insertion loss and cost. The type of diode has a major influence on the component performance; this is discussed in Section III-B.
- *Modules or complete components.* The designer has the option of integrating modules into his system or of obtaining complete components. The relative characteristics are shown in Sections III-C and III-D.
- *Reflective or absorptive circuit.* The basic switch and limiter circuits are reflective, but they can be combined with other components to form absorptive circuits. Examples are shown in Section VIII-D.

- *The type of bias network.* The effect of the bias network on the switch characteristics is second only to that of the diodes. This is discussed in detail in Section VII-E.

## B. Diode Types

Although a large variety of PIN switching diodes exists, they can be separated into two basic categories:

- *General purpose PIN diodes*, whose characteristics offer the best all-around switch, modulator, and attenuator performance.
- *High conductance PIN diodes*, which afford exceptionally fast switching.

Table 2 shows the relative characteristics of the diodes used in Hewlett-Packard modules and switches — the high isolation series (general purpose PIN diodes) and fast switching series (high conductance PIN diodes). The table clearly illustrates

that the high isolation series generally offers better performance unless fast switching speed or a wide modulation bandwidth is required. Selection based upon the most convenient bias polarity is often a mistake.

Limiter diodes are special versions of the high conductance diode that are designed to give a smooth and predictable limiting action. Although a limiter can be used as a switch, switching diodes do not generally give satisfactory performance as limiters.

## C. Modules

Almost all modern microwave switches and limiters use broadband modules as the basic building block. A module may have two or more ports, depending upon the circuit configuration (i.e., SPST, SPDT, etc.). Modules also come in various shapes for optimum integration into coaxial or stripline circuits, but the basic design is the same for all modules.

*Table 2. A Comparison of the Characteristics of the High Isolation and Fast Switching Series Modules and Switches*

| CHARACTERISTIC                       | COMPARISON                     |                             | FURTHER COMPARISON |
|--------------------------------------|--------------------------------|-----------------------------|--------------------|
|                                      | high isolation (gen. pur. PIN) | fast switching (Hi G PIN)   |                    |
| Diode Type                           | high isolation (gen. pur. PIN) | fast switching (Hi G PIN)   |                    |
| Diode Lifetime ( $\tau$ )            | 100 ns                         | 600 ps                      |                    |
| Switching Speed                      | 50 ns                          | 10 ns                       | IV F               |
| Isolation                            | typically 20% (in dB) higher   | typically 20% (in dB) lower |                    |
| Insertion Loss, VSWR                 | same                           | same                        |                    |
| Switching Transients                 | better                         | worse                       | IV G               |
| Noise and Harmonics                  | better                         | worse                       | IV I               |
| Temperature Effects                  | better                         | worse                       |                    |
| Power Handling Capability            | greater                        | less                        | IV K               |
| Isolation Sensitivity to Input Power | better                         | worse                       | IV L               |
| Polarity to Bias Switch OFF          | negative                       | positive                    |                    |
| RF Bandwidth                         | to 18 GHz                      | to 15 GHz                   |                    |
| Modulation Bandwidth ( $f_0$ )       | 1.6 MHz                        | 250 MHz                     | IV H               |

Each module is a hermetically sealed section of 50-ohm transmission line. At each end is a glass seal with a small wire center conductor forming a short section of coaxial line. The center section is an air dielectric microstrip. The ground plane is a shallow, rectangular groove milled into the module body, and the center conductor is a metal ribbon. Each change of mode or dimension is accomplished with a carefully designed broadband transition, so the module is an essentially reflectionless 50-ohm transmission line whose integrity extends above 18 GHz.

The diodes are chips, each measuring about 15 mils square by about 4 mils thick. These chips are die-attached directly onto the ground plane, and the center conductor ribbon is then bonded onto the diode contacts. Each module has some form of lid or sleeve which is welded or soldered to the module body after die attaching and bonding, resulting in a completely sealed package. An example of the module construction is shown in Figure 8.

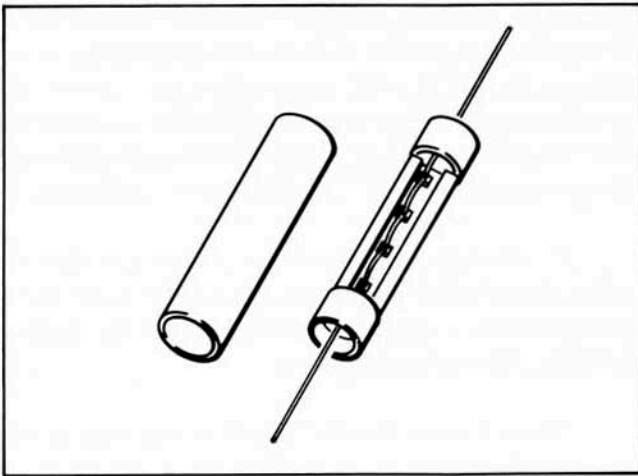

Figure 8. Cylindrical Module Construction.

Since the only "package" is the 50 ohm line, all package reactances normally associated with diodes are eliminated. The only reactance left to contend with is that associated with the junction capacitance. As explained in Section II, this reactance becomes a factor in the ON condition. By themselves, the two, three, or four diodes appear, when zero or reverse biased, like some value of capacitance in shunt with the line. At higher frequencies the associated susceptance becomes significant and causes reflections; the result is a smooth transmission rolloff, characteristic of a single-element low-pass filter.

With the junction capacitance as a constant, the passband of this filter is considerably extended by deliberately adding series inductance; this is done simply by altering the dimensions of the ribbon center conductor from that dictated by a 50-ohm structure. The result is now a five-, seven-, or nine-element low-pass filter whose rolloff is much sharper, but whose useful frequency range is considerably extended. Figure 9 shows the ON condition equivalent circuit of a two-diode module and the transmission with and without compensation with series inductance. The useful frequency range of these modules extends to 12, 15, or 18 GHz, depending upon the type and number of diodes.

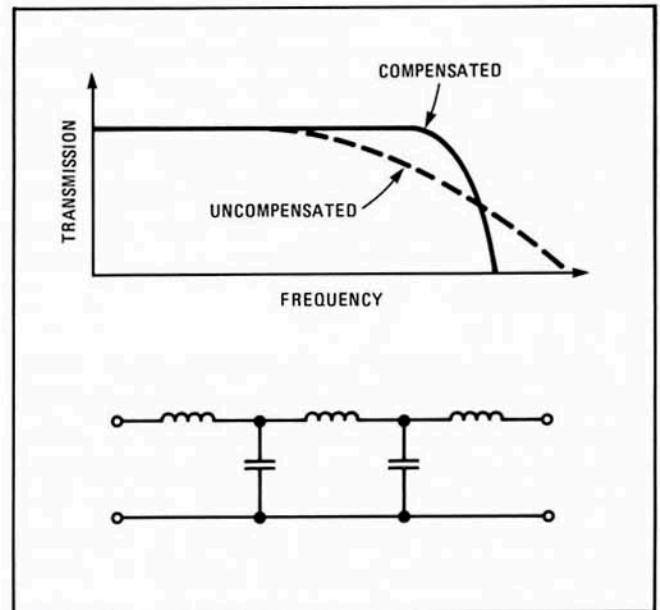

Figure 9. SPST Module Equivalent Circuit (ON Condition).

The designer can select modules which are optimized for coaxial or stripline applications. Different diode types are available and there is also a choice in the number of diodes. For high values of isolation, coaxial modules containing up to four diodes can be obtained; stripline modules are usually restricted to two diodes because of the difficulties of dealing with wide dynamic ranges in open lines. This is discussed further in Section VII-D.

Multithrow modules utilize the series-shunt configuration, generally with one series diode and two shunt diodes per arm.

#### D. Complete Switches and Modulators

A switching or limiting module is not a complete circuit; it must at least be combined with a

bias network, and usually also required dc blocks. If the requirement is for an absorptive component, still more circuitry must be combined with the module.

Complete components are available that combine the modules and the other elements into a single package, with connectors at the bias ports. The basic characteristics of these components are mainly those of the module; the type and/or number of the diodes affects the isolation, the upper frequency limit, the modulation bandwidth, the switching speed, the suitability of analog applications, and the power handling capability. Also, most of the insertion loss is in the module.

The switches and modulators modify these electrical characteristics to some extent. The operating frequency is limited by the passband of the bias network or the hybrid couplers. Switching speed or delay may be affected by the bias network. The connectors and circuitry add some additional insertion loss. The switching transient is attenuated by the dc block.

Cost and timing considerations often dictate that a systems manufacturer use complete switches, modulators, or limiters with connectors in evaluation, prototype, and even first production systems. For ultimate production, however, modules have advantages of cost and size, and can be integrated with other components. All that is required to make a smooth change from one form to the other is an understanding of the characteristics which are inherent in the modules and of those which are contributed by the switch, by the user's own housing and bias networks, and by the external circuitry.

The discussions in this application note concentrate on the characteristics of the modules, and then illustrate how these characteristics are modified by circuits or components external to the modules.

#### **IV. OPERATING CHARACTERISTICS AND IMPORTANT PARAMETERS OF SPST SWITCHES AND MODULES**

##### **A. The ON Condition**

Ideally, the SPST switch in the ON condition should look like a length of lossless transmission line, with no reflections, no insertion loss, linear phase shift, and no distortion, and should exhibit

all of these qualities over the specified bandwidth and range of input power.

In the modules, most of the reflections are found near the upper end of the specified bandwidth and are caused by the low-pass filter formed by the junction capacitance of the diodes and the compensating series inductance. In some cases a slight dip is noticed at a frequency about half of the upper operating limit; this is caused by a slight chebishev tuning of the low-pass filter.

Insertion loss in the modules is the sum of three loss components — mismatch loss, real loss in the transmission line, and real loss in the diodes. Since the VSWR of the modules seldom exceeds 1.7:1, and this only at the higher frequencies where the real losses are higher, mismatch loss is not a significant part of insertion loss. Transmission line loss stems from dielectric loss in the glass seals and copper loss in the center conductor, and typically accounts for about one-third of the total insertion loss.

The rest of the insertion loss is in the diodes: this loss is caused by the fact that the RF resistance of the diodes at zero or reverse bias never goes to infinity, but is instead several thousand ohms. Insertion loss with reverse bias is typically about 0.2 dB less than that with zero bias; 10 volts is sufficient to saturate the diodes to maximum RF resistance.

Phase shift characteristics of the modules are quite linear until the upper frequency limit is approached; then the phase shift follows the typical low-pass filter characteristics.

Distortion of the RF signal is very low at any bias level in the high isolation series; the fast switching series requires reverse bias to keep distortion to a minimum in the ON condition. This is discussed in Section IV-I.

A combination of high power, zero bias, and low bias supply impedance can result in limiting (i.e., an increase in insertion loss as input power is increased). The problem is relatively minor with the high isolation series but is significant with the fast switching series. If input power above the limiting threshold of the diode is to be handled, two methods can be used to prevent limiting. One is to supply reverse bias when in the ON condition, and the other is to use a driver that switches to a very high output impedance when not supplying forward current. This is discussed in Section IV-L.

The switches and absorptive modulators modify the module ON condition characteristics in two ways. First, they add some incremental increase in reflections and insertion loss which is relatively small in the switches and more significant in the modulators. Second, the filterlike characteristics of the switch bias networks and the modulator hybrids and filters cause nonlinear phase shift at their respective pass band edges.

## B. The OFF Condition

The OFF condition of diode switches has some significant characteristics, each of which must be considered in the light of the intended application. The following statements pertain to a switch module with two or more shunt diodes:

- The isolation\* varies as a function of bias current.
- The relationship between isolation and bias current is not linear. It is, however, a smooth monotonic curve with no fine-grain variation of attenuation.
- For a given bias, isolation varies with RF frequency.
- Transmission phase varies with isolation, and the phase vs. isolation curve changes with frequency.
- Power handling capability varies with isolation and frequency.

In order to understand the OFF condition characteristics of the module, some consideration of the equivalent circuit is required. To start, a single diode switch, represented by a variable resistor in shunt with a transmission line, is analyzed.

When this switch is connected to a generator and a load, as shown in Figure 10, the attenuation will vary with the normalized RF conductance ( $G$ ) as follows:

$$\text{Isolation, dB} = 20 \log_{10} \frac{2}{G + 2} \quad (1)$$

\*We define isolation as the two-port insertion loss of a switch when it is in the OFF, or partially OFF, condition. So, for a shunt diode switch, we use the term insertion loss when zero or reverse bias is applied. When any forward bias, no matter how small, is applied, the term isolation is used.

Note that this relationship between attenuation and conductance is nonlinear. Since the RF conductance of a diode is approximately proportional to bias current, isolation will vary with bias according to Equation (1) until the diode starts to reach saturation. This is shown in Figure 11.

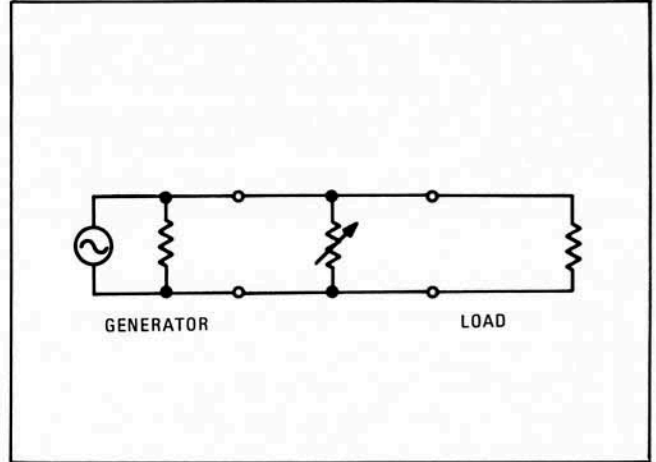

Figure 10. Equivalent Circuit of a Single Diode Shunt Switch.

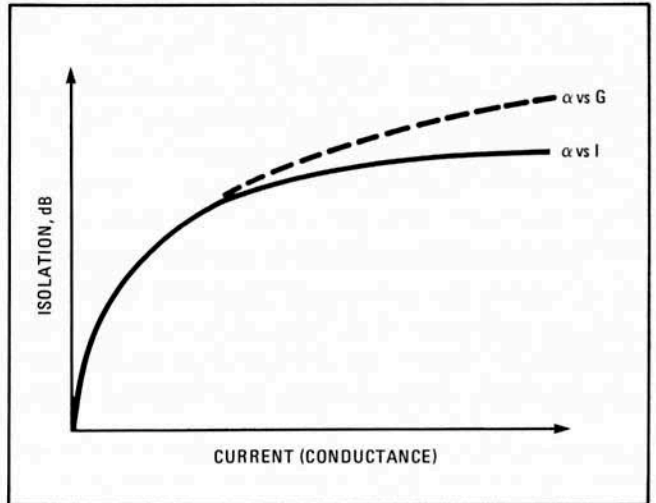

Figure 11. Isolation vs. Conductance and Bias Current, Single Diode Shunt Switch.

Since isolation in this circuit is a function of RF conductance only, and since RF conductance remains relatively constant as we vary frequency, isolation of a one diode switch does not change significantly with frequency.

It is important to note that although a shunt diode switch is considered to be a reflective device, not all of the isolation is caused by mismatch loss. A significant portion is resistive loss due to the power absorbed by the diode. There are two significant points related to this.

The first consideration is power handling. Figure 12 shows that as much as 50% of the incident power can be absorbed in the diode, and that this percentage loss remains fairly significant over a large portion of the dynamic range of the switch. What this means to the system designer is that diode switches used as analog devices (i.e., attenuators or modulators) will have a lower power handling capability than those used as switches (i.e., that are rapidly switched between full ON and full OFF and do not dwell at the point where power absorption is at maximum).

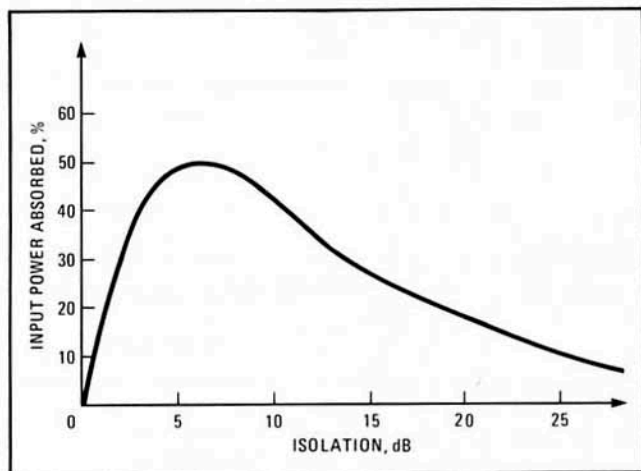

Figure 12. Percentage of Power Absorbed in a Single Diode Shunt Switch.

The second consideration pertains to the manner in which the reflections caused by the switch combine with those from other switches or external mismatches. Since only a portion of the isolation is caused by reflection, only that portion can be

varied by other reflective elements. The relative isolation caused by absorption and reflection in a single diode switch is shown in Figure 13.

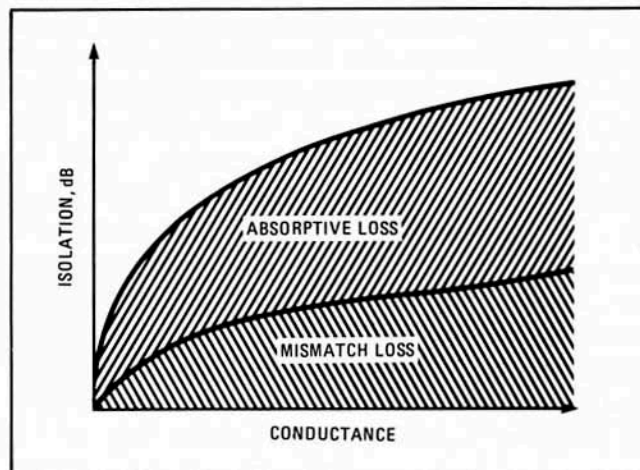

Figure 13. Relative Isolation Caused by Reflection and Absorption in a Single Diode Shunt Switch.

A single shunt diode typically gives less than 30 dB isolation, which is not enough for most system applications. Many requirements call for isolation up to 80 dB; for these, two or more shunt diodes are needed.

Since the isolation afforded by a single diode is partially due to reflections, the isolation from two or more diodes is affected by the electrical length between them, and therefore by frequency. Figure 14 shows the calculated isolation of switches containing two, three, and four diodes, as a function of frequency. Note that the isolation increases as

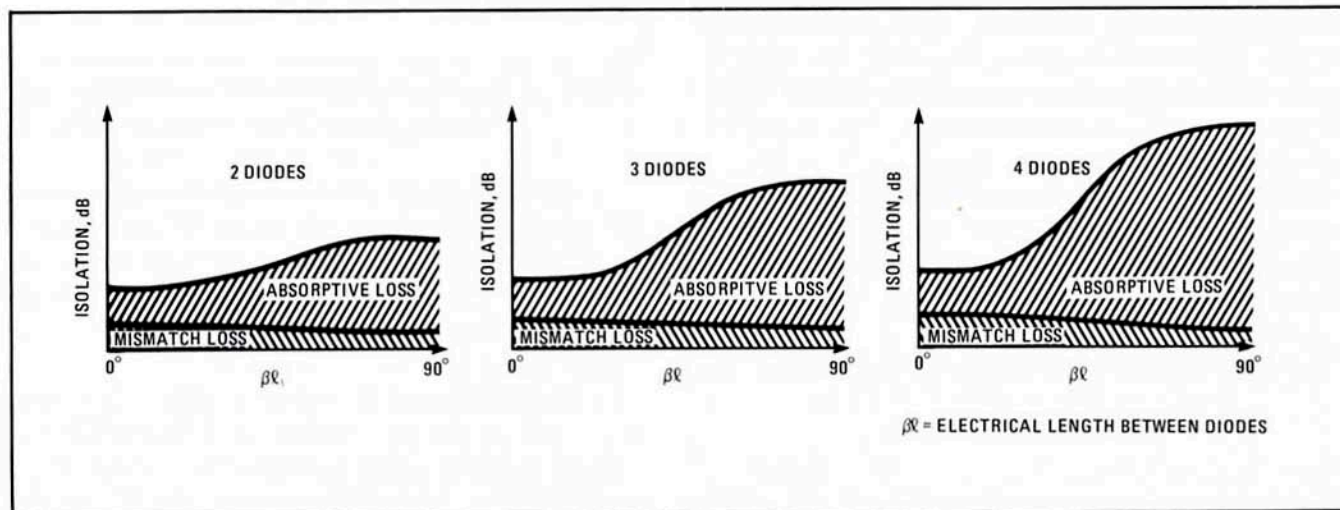

Figure 14. Isolation vs. Frequency of Multiple Diode Shunt Switches, Showing the Relative Isolation Caused by Reflection and Absorption.

the electrical length between diodes becomes significant, and that this increase is caused by absorptive loss, since the reflective loss actually decreases. The explanation for this is simplified if we consider only two conditions — one where  $\beta\ell \approx 0^\circ$  and the other where  $\beta\ell \approx 90^\circ$ .

Where the electrical length is insignificant, the diodes are all in shunt, and the circuit can be represented by a single conductance which is the sum of the conductances of the individual diodes. This reflects most of the incident power; that which is not reflected is divided between the combined diodes and the output load in proportion to their respective conductances. Since the conductance of the diodes is much greater than that of the load, most of the nonreflected power is absorbed in the diodes, which results in a significant absorptive loss added to the mismatch loss.

In the case where the electrical length between the diodes is approximately  $90^\circ$ , the diodes are no longer in a simple shunt circuit; rather, the high value of conductance of each diode is transformed over a quarter wavelength to a very low value. This means that the input admittance of the switch is essentially the conductance of the first diode, and since this is less than the combined conductances of two or more diodes (seen when  $\beta\ell \approx 0$ ), the mismatch loss is less than that at low frequencies.

The absorptive loss, on the other hand, is much higher. The power that is not reflected is divided between the first diode and the combined admittance of the subsequent diode(s) and the load. This admittance is essentially the conductance of the second diode transformed over a quarter wavelength to a very low conductance. Since the power division is proportional to the ratio of conductances, most of the nonreflected power is absorbed in the first diode. The same relative distribution takes place for each subsequent diode, and finally for the load.

Two or more switches may be combined for higher values of isolation. The total value of isolation varies with frequency, but in a somewhat complicated manner, since both the electrical length between diodes and the electrical length between switches must be considered. The following approximations apply for two switches:

At frequencies sufficiently low that the electrical length between the switches is insignificant, two switches give approximately 6 dB more isolation than one switch at that frequency.

At frequencies where the electrical length between the switches is an odd multiple of  $90^\circ$ , the isolation of two switches (in dB) is twice that of a single switch plus about 6 dB.

At frequencies where the electrical length between the switches is a multiple of  $180^\circ$ , the isolation varies from about 6 dB above that of a single switch (when  $\beta\ell$  between diodes in the switch is insignificant) to about 1.6 times (in dB) that of a single switch (when  $\beta\ell$  between diodes is near  $90^\circ$ ).

An example of the combined isolation of two switches is shown in Figure 15. Two 33602A modules were spaced approximately 0.64 inch apart and were biased at a relatively low level in order to keep the maximum isolation within the dynamic range of the measurement system. The results are shown for the individual switches and for the two combined.

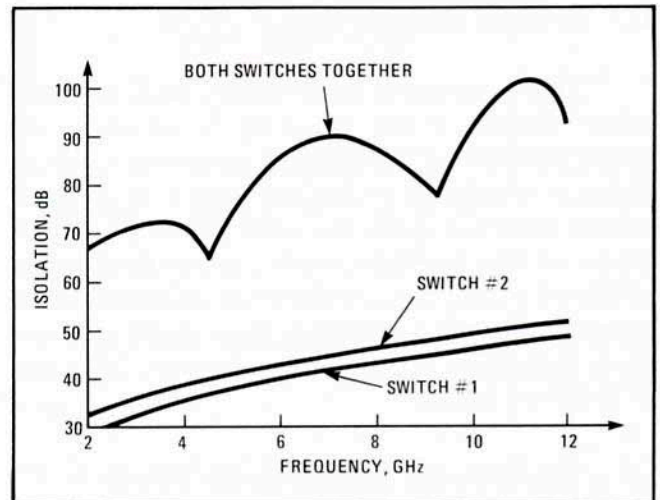

Figure 15. Combined Isolation of Two Switches.

If less variation of isolation with frequency is required, an isolator can be placed between the two switches, in which case the total isolation (in dB) is that of the two switches combined. If an increase in ON condition insertion loss can be tolerated, a pad can be used in place of the isolator. Relatively small values of padding will smooth out most of the ripple.

Since two or more reflective elements are used in the switch modules, the transmission phase in the OFF condition changes considerably with applied bias. Because the electrical length between these elements varies with frequency, the curve of phase vs. attenuation also varies with frequency.

The OFF condition characteristics of the switches are almost entirely those of the modules. A small ripple on the isolation vs. frequency curve can be caused by mismatches in the bias network or connectors phasing with that of the module (see Section IV-D), but this ripple is relatively small because the connectors and bias network generally present a good match.

The absorptive modulator, although it does not change the isolation of the modules, converts all of this isolation to absorptive, rather than partly absorptive and partly reflective. This means that the isolation characteristics are not modified by external mismatches and that absorptive modulators can be combined with other switches (either absorptive or reflective); the total isolation is the sum (in dB) of the individual switches, and this does not vary with frequency.

#### C. Reflection Loss

There are many applications, such as digital phase shifters, shunt mode SPDT switches, and SPDT switches utilizing switch/circulator combinations, in which one would like to recover all of the power reflected from the OFF condition switch. Some of the power, however, is absorbed in the switch; the ratio between the incident and reflected powers is termed reflection loss. Note that this term is *identical* to return loss; the only difference is in the application.

The two components of this loss are in the diodes and the transmission line. Since the diode RF resistance never goes to zero, some power is lost in the diodes and not all of it is reflected. We must add to this the round-trip path through the connectors, module glass seals, and the rest of the transmission line.

As a general rule to apply to SPST modules and switches, the reflection loss at any frequency is slightly less than the ON condition insertion loss.

To minimize reflection loss, the OFF condition bias current should be saturated, even though the isolation requirement may allow a lower current. Another point is that when using switches, the power should be reflected from the port that is connected to the diode module, in order to avoid power loss in the bias network.

#### D. Effects of External Mismatches

When a diode switch is in the OFF condition, external mismatches can alter the portion of the isolation that is caused by reflection\*. These mismatches phase with that of the switch, adding to and subtracting from the switch isolation as frequency is changed. The magnitude of change can be startling — for a typical case of 0.5 dB *reflection* loss, a single mismatch with a VSWR of 1.5:1 will change the switch isolation by +1.5 dB and -1.8 dB. Even a mismatch with a VSWR of 1.1:1 will vary the isolation by  $\pm 0.4$  dB. If the distance between the mismatch and the switch is significant, the ripple will be quite pronounced, with the isolation changing rapidly with small changes in frequency.

One result of this problem is that it is very difficult to measure the isolation of reflective switches accurately; this is discussed in Section IX-C. Even if isolation is accurately measured in a test setup, when the switch is put into the end-use system the isolation is likely to be different due to mismatches in that system.

A way to minimize this problem is to use an absorptive modulator. This kind of component is often used when frequency ripple, or the inability to attain precise attenuation, precludes the use of a reflective switch. Although the absorptive modulator does have some reflections, the magnitude of the ripple (or error) is considerably reduced.

It should be noted that this effect also takes place within the module, switch, or modulator; in other words, the mismatches inside these components phase with and therefore modify the reflections from the diodes. With properly designed elements this variation is small, and since the mismatches are very close to the diodes, the ripple frequency is low (the effect is a very gradual deviation from the “ideal” isolation curve, and isolation does not shift up and down rapidly with frequency). Also, the internal deviation is fixed and does not change as the switch is moved from one system to another.

\*This topic is discussed in detail in HP Application Note 56, “Microwave Mismatch Error Analysis.” The material has also been reprinted in HP Application Note 64.

## E. RF Leakage

A very important consideration when dealing with high isolation switches is RF leakage. The very large dynamic difference between input and output when the switch is OFF means that all possible leakage paths must be eliminated. As will be shown in Section VII, this is the most critical design problem encountered when using modules.

When switches or absorptive modulators are used, RF leakage is normally not a problem, because the body and connectors are designed to suppress leakage well below the level of the switch/modulator isolation under all rated environmental conditions.

In some systems RF leakage out of the bias port can be a problem. The bias network on all switches, by virtue of their line length (inductance) and the bypass capacitors, typically isolate the bias port from the RF on the main line by 30 dB to 50 dB. For applications requiring higher isolation the 33200 series is available with an optional filter built into the bias port (332XXB). This is a four-element, low-pass filter with a 400 MHz cutoff; this gives excellent bias port isolation and still maintains a good video bandwidth. Switches so equipped have a minimum bias port isolation of 70 dB for frequencies above 1 GHz.

The user can also use a low-pass filter external to the switch. The cutoff frequency and slope should be chosen to be compatible with switching speed and delay requirements.

It is good design practice to orient the switch so that the input port is the end away from the bias port.

## F. Fast Switching

Before turning to the discussion of fast switching, some of the terms used when describing switching must be precisely defined. Referring to Figure 16,  $T_D$ , the delay time, is the interval between the time when the beginning of the driving pulse arrives at the bias port (in the case of the modules, at the diodes) and the time when the diode starts to switch.

$T_{ON}$ , the turn-on time, and  $T_{OFF}$ , the turn-off time, are defined as the time it takes to go from 10% to 90% and from 90% to 10% of the insertion

loss level. This is an industry standard definition and is used because it can be precisely measured on an oscilloscope display, which is the way switching speed is usually measured.

Unless otherwise defined, the 10% and 90% refer to *power*, which is equivalent to -10 dB and -0.45 dB. This corresponds to the display when the RF power is detected in a square law detector and displayed on a real time oscilloscope. For very fast switching speed, sampling oscilloscopes are often used, in which case the RF is fed directly into the sampler and the display is proportional to *voltage*. In this case, 10% and 90% correspond to -20 dB and -0.9 dB. For most switch/driver combinations the switching times measured either way are usually within 10% of each other.

The switching speed of HP modules, switches, and modulators is conservatively rated — all of them can be switched considerably faster than the guaranteed specification. The reason for the conservative rating is that the switching speed that can be attained is dependent upon a number of variables, some of which are tradeoffs against other parameters.

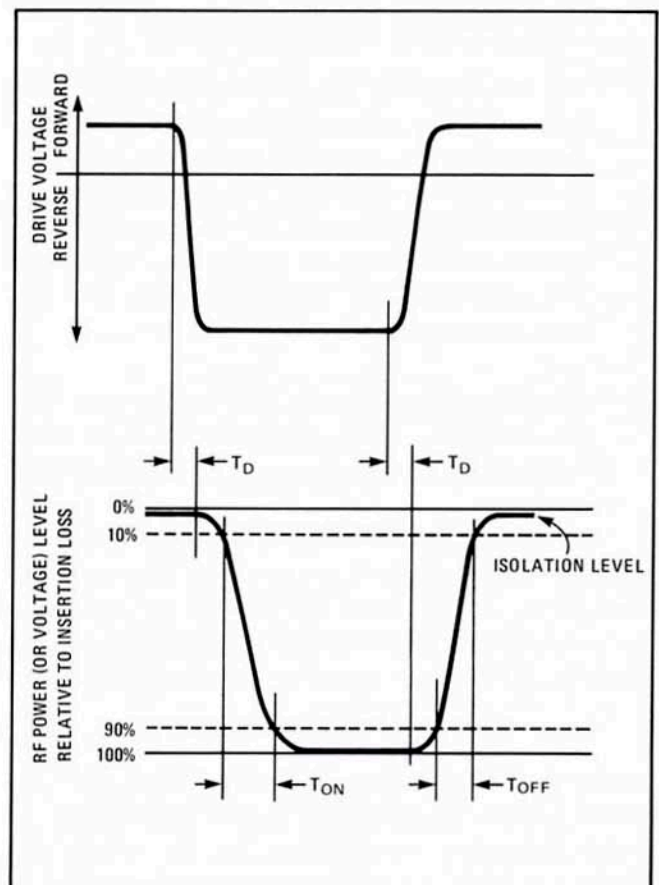

Figure 16. Switching Definitions.

To switch a shunt diode circuit from ON to OFF we must inject a charge into the diodes; to switch it from OFF to ON, we must completely remove this charge. When the fastest OFF to ON switching speed is required, one should use the lowest steady state bias current that is consistent with the required isolation level. The less charge, the faster it can be removed. The speed at which we can inject and remove this charge is dependent on two factors: the diode lifetime  $\tau$  and the magnitude and rise time of the switching pulse.

As shown in preceding sections, the switching speed obtainable with a given diode is proportional to  $\tau$  (with an optimum pulse, switching times on the order of  $1/10 \tau$  can be realized), but the choice of the fastest diodes is made at the expense of other parameters.

The ideal switching pulse is spiked; in other words, the initial amplitude of the pulse is much greater than the steady state value. In order to get optimum switching speed from a given diode, the spike (illustrated in Figure 17) should have the following characteristics:

1. The rise time of the spike should be as fast as possible, ideally 100 times faster than  $\tau$ .
2. The amplitude of the spike should be as large as the diodes will safely handle. To turn the switch OFF, the current spike may be as high as 0.5 ampere per diode; to turn the switch ON, the voltage spike should approach the reverse breakdown of the diodes (100 volts for high isolation series, 40 volts for fast switching series).
3. The duration of the spike should be such that the maximum spike amplitude is maintained until after the diodes have completely switched.

The amplitude, rise time, and duration of the spike are all determined by the driver circuit. Driver circuits are available that will provide current spikes in excess of 1 ampere and voltage spikes greater than 20 volts, all with rise times of a few nanoseconds.

These rise times approach the ideal requirements ( $\tau / 100$ ) for high isolation diodes, but not those for the fast switching diodes. Subnanosecond pulse generators are available, but the voltage and current magnitudes are generally too small to be useful for this application. Faster switch drivers

could be constructed; however, the usefulness of such devices would be limited by the video frequency response of the bias network and the RF circuitry.

The types of switches we are discussing here are "unbalanced switches" (i.e., the bias signal appears on the same transmission line as the RF signal). The bias circuit must be separated from the RF circuit by frequency sensitive networks — specifically, by the bias network, which introduces the bias to the diode and prevents the RF from leaking into the bias circuit, and by the blocking network, which prevents the bias from leaking into the RF circuit. Both of these networks are ordinarily simple one- or two-element filters, and both of them limit the bandwidth, and therefore the rise time, of the bias signal. There are a number of ways in which this effect can be minimized; these will be discussed in detail in Section VII-E.

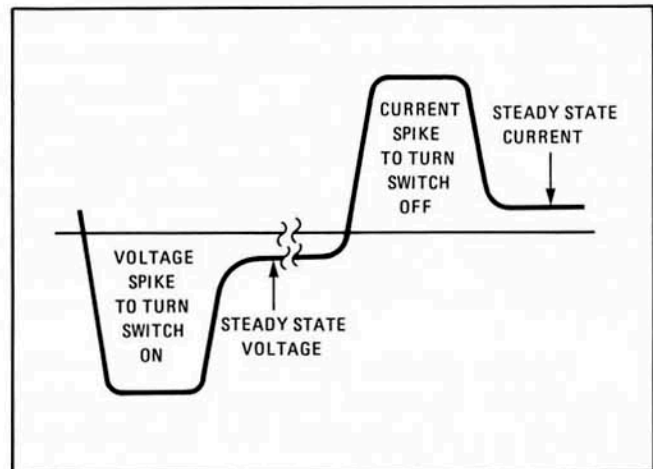

Figure 17. Switching Pulse for Shunt Diode Switches.

It is obvious that the lower the RF operating frequency, the lower the video bandwidth of the bias circuit. This is the primary reason that the 33200 series switches will switch faster than the 33100 series, even though they use the same modules.

The delay time ( $T_D$ ) of PIN diodes is essentially unmeasurable, so any delay in a switch is caused by the bias network and, to a lesser extent, the blocking networks in conjunction with the video impedance of the RF circuitry as seen at the input and output of the switch. Again, this delay time is greater with switches whose RF bandwidth extends to lower frequencies.

In summary, the designer must consider three major points which affect the speed of a switching circuit: the lifetime of the diodes; the rise time, amplitude, and duration of the driver spike; and the video bandwidth of the bias and blocking networks.

An important concern in many systems is the switching speed over a much wider dynamic range than 10% to 90%. As will be explained in Section IX-D, the reason that switches are commonly specified over this narrow range is that nanosecond measurements over wider dynamic ranges are difficult to make and to interpret correctly. A good approximation is that diode switches will switch over their entire dynamic range in two or three times the 10-90% or 90-10% switching times.

A typical example of a driver circuit which has worked well with HP diode switches is shown in Figure 18. The National Semiconductor DH0035 will supply current in either direction, so it is applicable to the high isolation series, the fast switching series, and the SPDT switches. As shown in Figure 18, it is connected to a high isolation switch, and  $R_1$ , the steady state current limiting resistor, is connected to the negative supply; for one of the fast switching series,  $R_1$  would be connected to the positive supply. The SPDT switches require current in either direction, so current-limiting resistors would be connected to both power supplies (two drivers would be required, one for each arm).

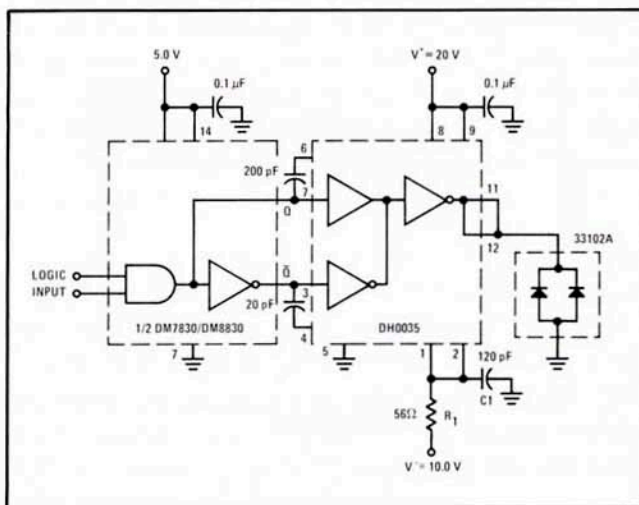

Figure 18. Driver Circuit (by permission of National Semiconductor Corporation, Santa Clara, California)

The current spike duration is established by the combination of  $R_1$  and  $C_1$ . This circuit does not employ a voltage spike; the initial voltage is the

same as the steady state level. The maximum allowable voltage between  $V^+$  and  $V^-$  is 30 volts; some adjustment of the proportions shown (+20 V, -10 V) can be made to optimize either OFF or ON switching times (i.e., +15 V and -15 V, with an appropriate change in  $R_1$ , would improve turn-off time at the expense of turn-on time).

Typical switching times achieved with this driving circuit and HP 33200 series switches are 25 ns OFF to ON and 5 ns ON to OFF for the high isolation series, and 5 ns OFF to ON and 4 ns ON to OFF for the fast switching series. Further information on this circuit is available in AN-49, published by National Semiconductor Corporation, Santa Clara, California.

For bench setups, a suitable driver can be obtained by combining a standard laboratory pulse generator and a dc power supply. Details are given in Section IX-D.

#### G. Switching Transients on the RF Line

A problem is often encountered, when switching low-level RF signals, in that a portion of the switching pulse appears on the RF line. This is a particularly serious problem where the conversion component is a broadband detector and the switching transient, which may be orders of magnitude greater than the RF, completely blanks out parts of the required signal.

The solution to this problem involves tradeoffs with switching speed, RF bandwidth, and system complexity. The easiest step is to generate the smallest possible pulse consistent with the required switching speed. This is accomplished by:

1. Using slower diodes, if possible. Fast switching diodes generate harmonics of the switching pulse.
2. Using the slowest possible driving pulse, reducing the rise time rather than the magnitude. (When using a driver with a fixed rise time, such as the one shown in Figure 18, the pulse rise time can be adjusted by placing the current-limiting resistor between the driver and the switch. A capacitor shunting the switch will then form an RC network which can be adjusted for the proper rise time).

The next step is to add additional filtering beyond the switch. Depending upon the RF frequency and bandwidth, there are several types of filters which will help suppress the switching transient:

1. A series blocking capacitor that is as small as possible, consistent with RF frequency.
2. A multielement high-pass filter.
3. A quarter-wave open stub in series with the line, with the highest impedance (narrowest RF bandwidth) possible.
4. A short section of waveguide. If the RF bandwidth and size and weight considerations allow, this is the ideal solution, since a relatively short section will reduce the transient to a negligible level.

#### H. Analog Applications

Both reflective and absorptive diode switches are used extensively for analog applications such as modulation and variable attenuation. Although the basic operating concept is straightforward, operation in the partial bias region introduces a whole series of considerations not encountered in digital (i.e., switching) applications.

One consideration is the nonlinear relationship between bias current and isolation. Another is the repeatability of this bias-isolation curve over time and temperature, and the uniformity of this curve from unit to unit. Noise, harmonics, and phase and power modulation also become important. Most of these considerations can be resolved by the proper selection of the component and by proper design of a driver circuit.

*The first rule* is to use slower diodes unless the modulation bandwidth demands the fast switching units. The high isolation series has a modulation bandwidth of about 2 MHz, and this can be extended easily by using a preemphasis network with a 6 dB/octave slope. Fast switching diodes generate distortion of both the RF and the modulating signal and change attenuation level as the RF level varies if the RF level is 0 dBm or greater.

*The second rule* is to consider an absorptive system. This can be a complete absorptive modulator or, if bandwidth and temperature considerations

allow, a reflective device can be combined with circulators. Assuming that other circuit considerations do not require an absorptive system, the major argument for this approach is that other system mismatches will not affect the bias-isolation relationship (see Section IV-D).

The nonlinearity of the bias-isolation curve is inherent in the device, and if the system will not tolerate this the curve must be linearized in the driver circuit. The easiest approach is to use a linear current amplifier with a relatively high impedance input. The shaping circuit is located at the input of this amplifier, where low levels and reasonable impedances make its design much simpler.

The normal distribution of the bias-isolation curves from unit to unit often poses a problem to the systems designer. One solution is to buy units selected to a tight corridor, but this is very expensive and batch variations can lead to uncertain delivery from the manufacturer.

A much better approach is to compensate for this variation in the driver circuit. An examination of a typical distribution of bias-isolation curves (Figure 19) shows that all of the curves are smoothly diverging without significant crossovers; thus a current divider could be used to bring all units within a tight corridor.

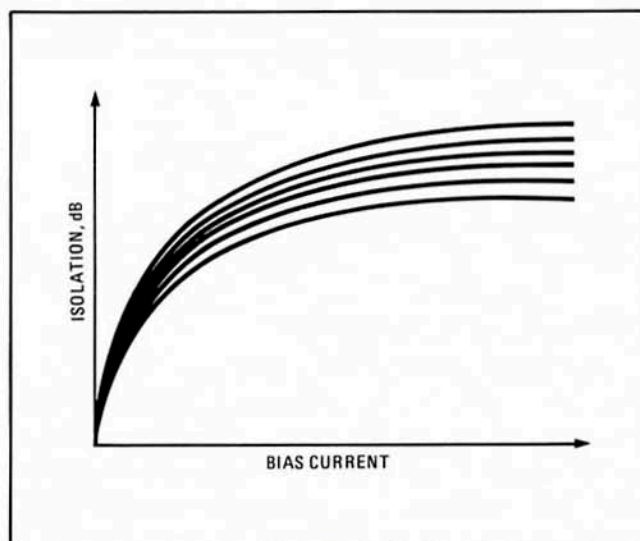

Figure 19. Typical Distribution of Bias vs. Isolation Curves.

Since the diode resistance changes with current, a simple current divider network is not practical, but if the linear current amplifier is used, a simple voltage divider can be inserted between the shaping

network and the amplifier. This voltage divider can be used to compensate for both the bias-isolation variations and any variations in the amplifier gain.

The change in phase with attenuation is also an inherent characteristic of diode control components, but the phase-attenuation curves of modules are remarkably consistent from unit to unit. A sample of ten 33602A modules measured over a 50 dB dynamic range at 3.5 GHz fell within a 7° corridor. Compensating for slight variations in line length, the corridor width was only 4°.

Switches and modulators add some additional line length variation, which can be easily compensated since it is linear. However, near the band edges of the bias networks and modulator hybrids, non-linear phase variations become apparent.

#### I. Noise and Harmonics

PIN diodes have an equivalent noise temperature of approximately one; that is, they do not generate noise in excess of that of an equivalent resistor. Situated in the input of a receiver, the noise figure of a PIN diode switch is equal to the insertion loss. This relationship applies at any bias level.

Harmonic distortion is not significant in the high isolation series switches; they are at least 40 dB below the fundamental at any bias, any power level up to 2 watts, and any frequency down to 400 MHz. With the fast switching series, harmonics can become a problem at intermediate bias levels if the RF level exceeds 1 mW. However, when used as a switch (i.e., biased either full ON or full OFF), harmonics are down at least 20 dB from 1 to 4 GHz and 40 dB above 4 GHz, for RF power levels up to 0.5 watt.

#### J. Temperature Effects

When PIN control components are used as switches, temperature effects on performance are not a major factor. Isolation changes very little and remains greater than its specified minimum. VSWR change is negligible. Insertion loss increases with temperature, but even this change is relatively small.

In analog applications, variation of attenuation with temperature can be a problem at intermediate

levels. For a constant current, attenuation may vary nearly 10 dB over a wide temperature range. Fortunately this can easily be compensated by any of several methods.

The first method involves tailoring the driver impedance. The temperature coefficient of isolation is negative (isolation goes down as temperature is raised) when a constant current is applied, but it is positive for a constant voltage. It follows that some optimum driver impedance will result in a zero temperature coefficient.

For example, consider the 33602A biased for 20 dB isolation at 5 GHz. Biased with a constant current, the isolation varies  $\pm 2.6$  dB when the temperature varies from  $-55^{\circ}\text{C}$  to  $+105^{\circ}\text{C}$ . With a constant voltage, the isolation varies  $\pm 2.3$  dB. But with a bias impedance of 600 ohms, the total variation over the temperature range is only  $\pm 0.2$  dB. The impedance value is not critical; any value between 400 and 1000 ohms will keep the variation to within  $\pm 0.7$  dB.

The optimum impedance for minimum temperature variation is different for other attenuation values, but a reasonable compromise can be made over a given attenuation range. In the example given above, the optimum impedance for 15 dB is 700 ohms; for 25 dB it is 300 ohms. A compromise of 500 ohms will keep the variation to less than  $\pm 0.5$  dB at any setting from 15 to 25 dB over the  $-55^{\circ}\text{C}$  to  $+105^{\circ}\text{C}$  range.

In many systems other circuit considerations define the driver output impedance, so the above method cannot be used. In these cases, a sensistor can be put in parallel with the switch. The sensistor, which has a positive temperature coefficient of resistance, draws less current as temperature is increased, thereby shunting more current into the switch. The optimum resistance value of the sensistor depends upon the number and characteristics of the diodes, the driver impedance, the attenuation level, and to a lesser extent the frequency. As an example, for a 33602A biased to 20 dB at 5 GHz with a current source, 2000 ohms was found to be the optimum sensistor value and maintained the attenuation within  $\pm 1$  dB from  $-55^{\circ}\text{C}$  to  $+105^{\circ}\text{C}$ .

A third method is to build a temperature compensating network at the input to the driver. With all methods, the temperature characteristics of the driver and its input signal must be considered, and

the temperature compensating scheme must compensate for all of the variations in the system.

### K. Power Handling Capability

The RF power, CW or pulse, that can be handled safely by a diode switch is limited by two factors inherent in the switch — voltage breakdown of the diodes, and thermal considerations, which involve maximum diode junction temperature and the thermal resistance of the diodes and packaging. Other factors in determining power handling capability are ambient temperature, frequency, isolation level, switching speed, pulse duty cycle, and pulse width independent of duty cycle. This is illustrated in Figures 20, 21, and 22, which show the power handling curves for the high isolation and fast switching series, as well as the temperature derating curve.

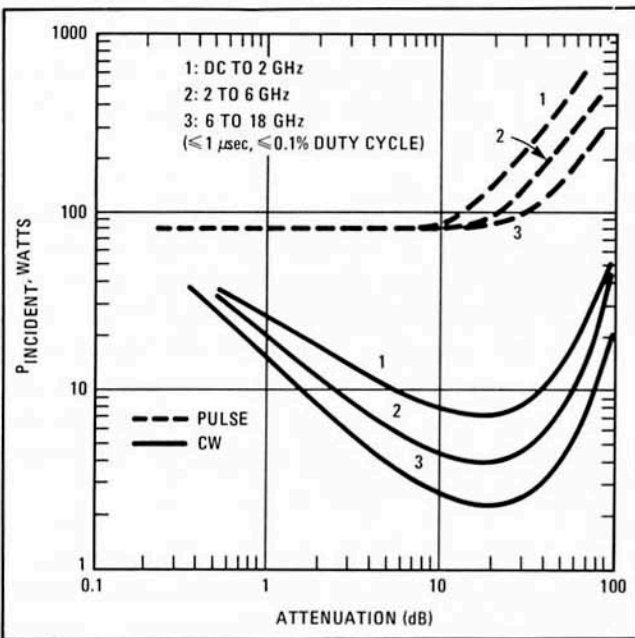

Figure 20. Power Handling Curves for High Isolation Series.

In the case of the high isolation series, the CW power handling is limited solely by thermal considerations. At any given temperature the diodes can dissipate some level of power; the percentage of incident power absorbed by the diodes depends upon both the attenuation level and the frequency.

In a two-diode switch, when the frequency is low enough so that the electrical length between the diodes is insignificant, maximum power absorption takes place when the diodes are each biased to 50 ohms. Each diode absorbs 25% of the incident power; the isolation level is 6 dB. At higher frequencies, where the electrical length approaches 90°,

maximum absorption takes place when the diodes are each biased to 25 ohms. The diode closest to the source absorbs 72% of the incident power, and the isolation is 14 dB.

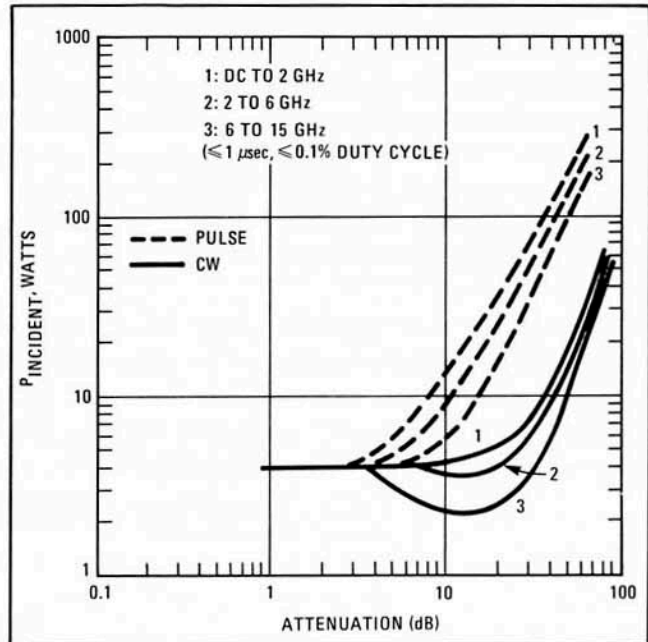

Figure 21. Power Handling Curves for Fast Switching Series.

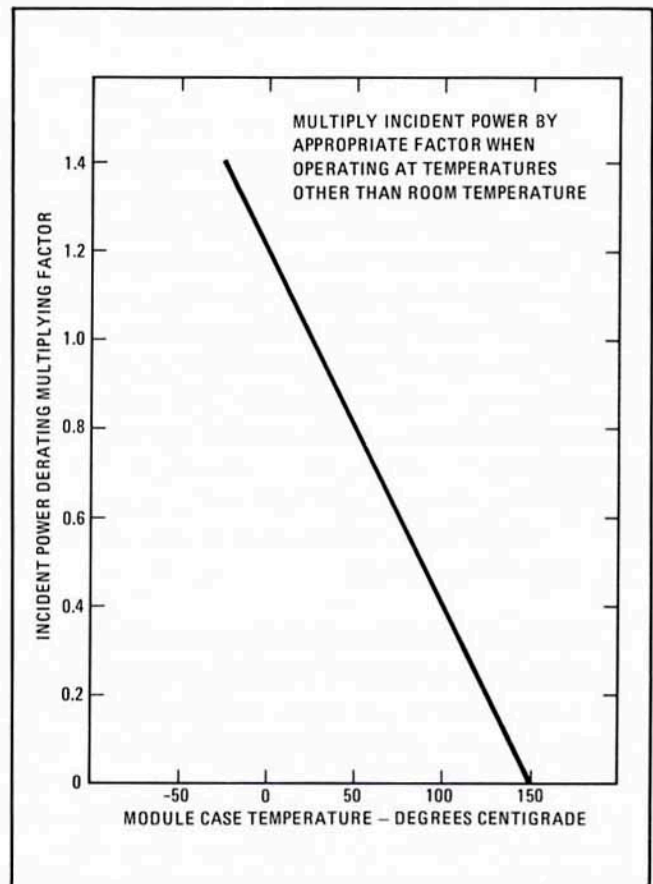

Figure 22. Temperature Derating Curve.

The CW power handling curves in Figure 20 clearly illustrate this. If the switch is to be used as an attenuator or modulator, the lowest point on the appropriate frequency curve must be used. For switching applications, the steady state points (insertion loss and isolation) on the curve can be used if the switching time is 1 microsecond or less. However, the designer should be aware of a potential problem.

Section IV-L discusses how high RF powers will cause even slow diodes to rectify to some degree and change the attenuation level. The problem is solved for the insertion loss state simply by applying a small reverse bias. If the bias should fail, the switch will rectify and bias itself to some level above insertion loss. Referring to Figure 20, a four-diode switch operating at 6 GHz will handle 10 watts at 25°C, if it is switched rapidly between 1 dB and 80 dB. If the bias fails, the switch will self-bias to some point in excess of 5 dB, and the switch will fail.

For short duration (1 microsecond or less) low duty cycle pulses the power handling is limited by voltage breakdown. The voltage seen by the diodes is the sum of the bias and the peak RF voltage. The high isolation series, with a minimum reverse breakdown of 100 volts, is specified at 80 watts; this is about 90 volts peak and allows 10 volts for reverse bias, which is sufficient to prevent rectification at this power level.

The fast switching series, with a minimum of 40 volts breakdown, is specified at 4 watts, which allows for 20 volts peak RF voltage plus 20 volts dc, which is needed to prevent rectification of these fast diodes at this power level. Notice that this limits CW power in the ON condition.

In both cases, peak power handling is increased at higher isolation levels.

Peak power is also limited by thermal considerations. First, there is the simple case in which the peak power times the duty cycle should not exceed the CW power rating. In addition, the thermal time constant of the diodes is such that pulses longer than 1 microsecond begin to appear as if they were CW. Figure 23 shows the derating curve for pulse widths greater than 1 microsecond. Keep in mind that all power handling curves must be derated if the ambient temperature is above 25°C.

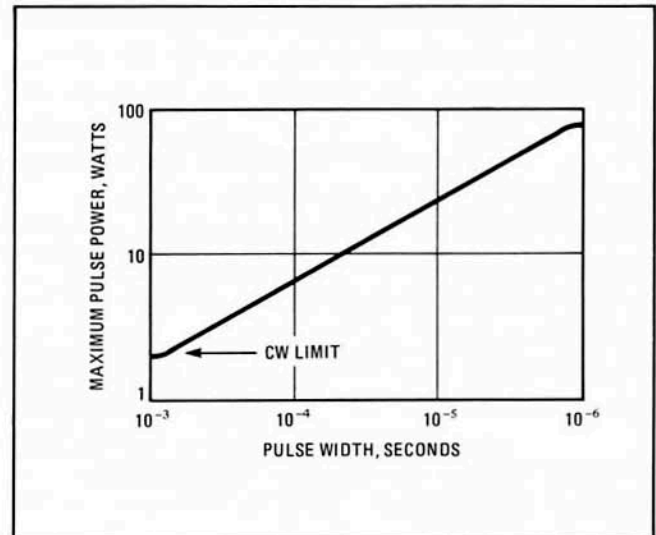

Figure 23. Pulse Width Derating Curve.

#### L. Isolation vs. Input Power

At RF power levels above 0 dBm, PIN diodes will begin to rectify, resulting in some modification of the insertion loss or isolation. The problem and the appropriate solution are somewhat different at the three states: ON, FULL BIAS OFF, and PARTIAL BIAS OFF.

Figure 24 illustrates the attenuation vs input power of a 33604A switching module at 6 GHz. In the ON condition, rectification begins to increase insertion loss above +18 dBm. There are two very simple solutions to this problem. A small reverse voltage (10 volts) will prevent rectification at power levels up to 80 watts, the peak rating of the switch. Or, if a reverse bias is not available, a bias circuit that switches to a high output impedance (>100 KΩ) when not supplying current will also prevent rectification.

The problem is identical with that of the fast switching series, except the increase in insertion loss starts at about +8 dBm, and reaches about 10 dB at +27 dBm. However, both of the above solutions work equally well with the fast diodes; the reverse bias should be increased to 20 volts.

In the FULL BIAS OFF condition, this rectification is not considered to be a problem. The switch is biased into saturation, and small rectified currents make almost no change in isolation. This is true for both the high isolation series and the fast switching series.

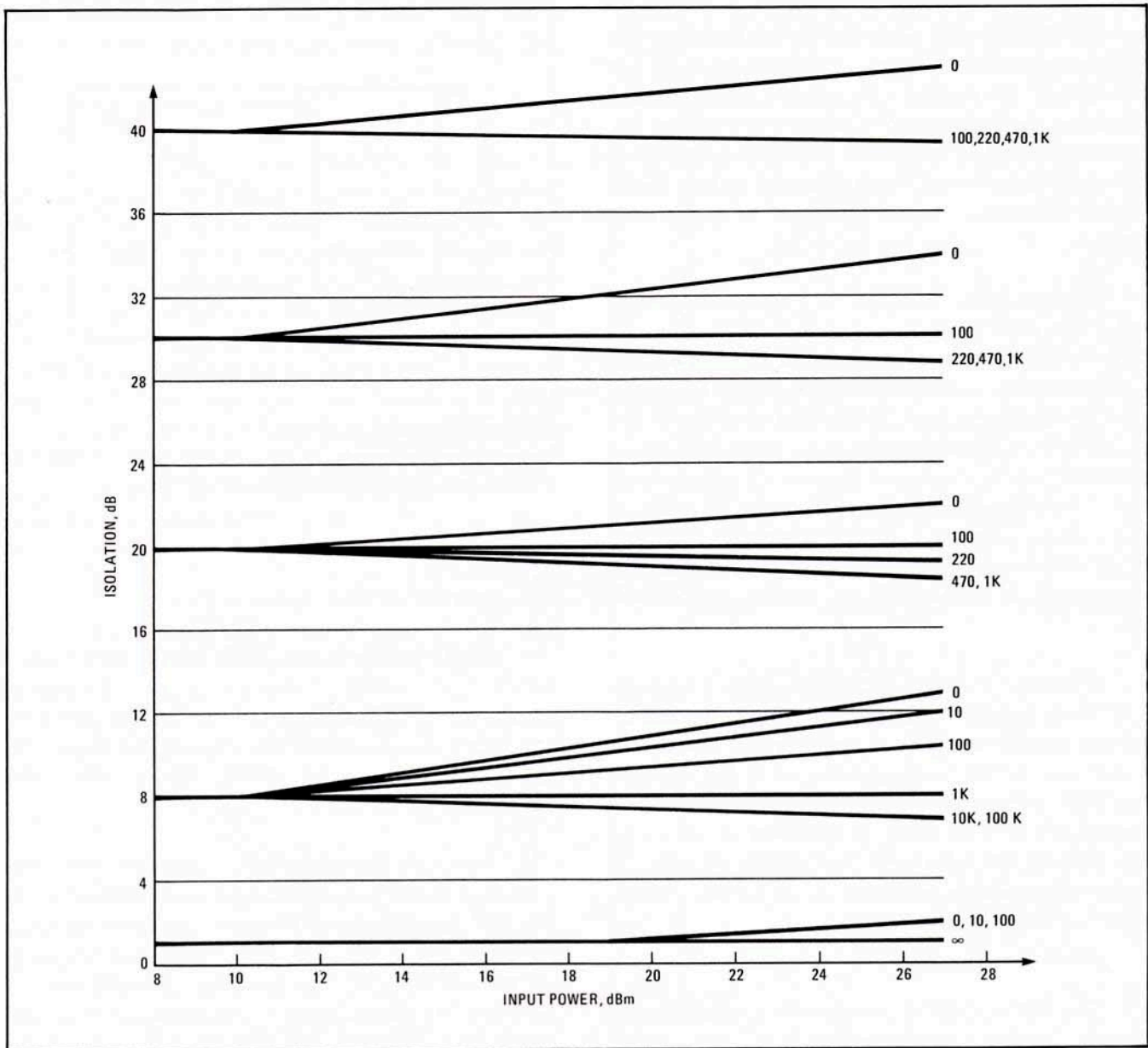

Figure 24. Attenuation vs. Input Power with Driver Impedance as a Parameter.

It is in the partial bias condition that this effect can be troublesome. As shown in Figure 24, isolation can be changed several dB as RF power is increased from +10 dBm to +27 dBm. Since this effect is a function of the driver impedance, this impedance can be adjusted to minimize the problem. For a single isolation level the problem can be eliminated, and over the entire dynamic range of the switch this effect can be held to an acceptable level with a driver impedance of a few hundred ohms.

The module characterized in Figure 24 is a four-diode switch, which exhibits this effect to a greater degree than two-diode modules.

The problem is so pronounced with fast switching modules that they should not be considered for analog applications above 0 dBm.

## V. OPERATING CHARACTERISTICS AND IMPORTANT PARAMETERS OF SPDT SWITCHES

### A. Normal Operating Conditions

The usual application for a single pole, double pole switch is digital, where a single input (or output) is rapidly switched between two outputs (or

inputs). Since each arm is independently biased, two drivers are required. For the series-shunt circuit each driver must be capable of supplying 50 mA in either polarity. This is because each arm contains both series and shunt diodes; the series diode draws positive current when the arm is ON and the shunt diodes draw negative current when the arm is OFF. A driver circuit such as that shown in Figure 18 is suitable for this type of switch.

In normal applications both drivers are triggered simultaneously. The ON arm goes OFF within a few nanoseconds, but the other arm does not reach the ON condition for at least 50 ns. The switch action is therefore break-before-make, and the common arm appears as a total reflection for a short period of time. For applications where this is not suitable, the trigger pulses can be offset by a period equal to the switching time; the resulting switching action will be make-before-break and the common arm mismatch will not exceed 2:1.

Each arm/driver combination is completely independent of the other, and the switch has four steady state conditions:

- Arm 1 ON, arm 2 OFF
- Arm 1 OFF, arm 2 ON
- Both arms ON
- Both arms OFF

There are also some SPST applications where series-shunt SPDT switches are appropriate. One is a wideband application in which high isolation is required at low frequencies. Below 2 GHz the isolation of these switches is higher than that which can be typically attained with a single shunt diode switch, and the frequency range extends far above that of a series diode switch.

The other application occurs when one arm is terminated and the SPDT switch is used as an absorptive SPST switch or modulator. The arms are switched in a make-before-break sequence, so the common arm mismatch would not exceed 2:1 (this could be improved by trimming the sequence so the ON arm starts to go OFF slightly before the other arm reaches the ON condition).

## B. Circuit Considerations

As mentioned in preceding sections, the series shunt circuit provides the best broadband performance for SPDT switches. There is one drawback — the

dc circuit has the diodes arranged in a ring, and this can have a negative effect on both switching speed and power handling capability.

A glance at the basic schematic shown in Figure 5 will reveal that in the dc circuit the series diode is in parallel with the shunt diode, with the anode of one connected to the cathode of the other. Regardless of the polarity applied to the bias port, one of the diodes will be forward biased; this means that the reverse bias across the other diode will never exceed 0.7 or 0.8 volt.

In preceding sections it was shown that reverse bias is required under two conditions — for fast switching from OFF to ON, and to prevent rectification in the ON condition when handling higher RF power. If fast diodes are used, switching speed is improved but the rectification problem limits the power handling to less than 0 dBm.

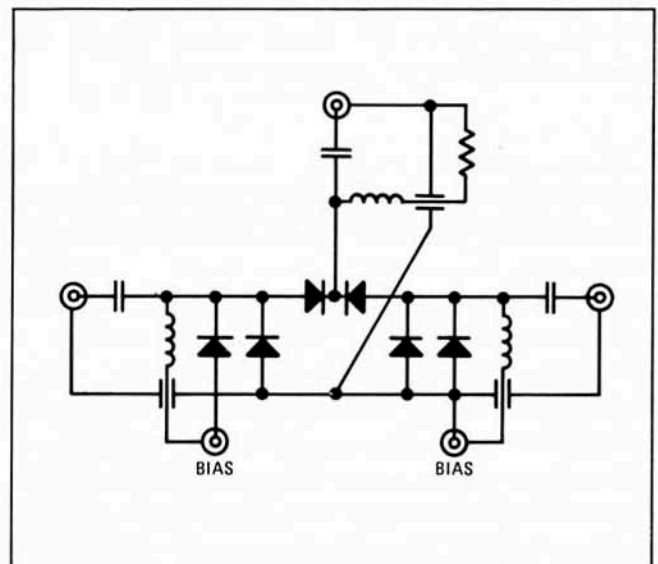

Figure 25. SPDT Switch Schematic.

A reasonable solution to this problem is to lift the common arm dc return off ground and insert a resistor, as shown in Figure 25. A bypass capacitor grounds the dc return for the RF. Inspection will show that when the bias port of one arm is biased positive the series diode is conducting, and the reverse bias applied to the shunt diodes is the voltage drop across the resistor plus the voltage drop across the series diodes. In the other arm, which is biased negative, the reverse bias applied to the series diode is the sum of the resistor voltage and the voltage across the shunt diodes.

It has been determined experimentally that the optimum resistance value for a typical switch is about 100 ohms. In the steady state condition of 50 mA bias, this gives a reverse voltage of more than 5 volts, which prevents rectification at any power levels within the burnout capability of the diodes. At the same time, the power lost in the resistor, 250 mW, is not excessive.

The 100 ohm resistor gives a 25 volt pulse when switching spikes of 250 mA are introduced. In a typical switch using general purpose PIN diodes, this will improve the switching speed from 200 ns to 80 ns. This is measured from the time the isolation in one arm increases by 0.5 dB to the time the isolation in the other arm is reduced to 0.5 dB above insertion loss. In other words, this is an 89% to 89% measurement, and assumes that both arms are switched simultaneously.

Note that the resistor is seen by the driver only when a positive bias is applied, so the current limiting resistors in the driver circuit will be different for the positive and negative supply.

## VI. OPERATING CHARACTERISTICS AND IMPORTANT PARAMETERS OF LIMITERS

### A. Characteristics below Limiting Threshold

When the RF power incident upon a diode limiter is below the limiting threshold, the characteristics of the limiter are the same as those of a shunt diode switch in the ON condition. The diode resistance is high enough so that it does not affect the impedance. The diode capacitance is combined with some compensating series inductance to form a low-pass filter, and the impedance is essentially 50 ohms within the specified bandwidth. Above that point, response drops off rapidly.

Insertion loss is similar to that of a two-diode switch; it consists of loss in the diodes and some transmission line loss in the module itself. Phase shift is linear except near the low-pass cutoff. Noise and distortion are negligible at power levels below limiting.

### B. Characteristics at and above Limiting Threshold

When the incident RF power increases to the threshold level, the RF voltage is higher than the

diode junction voltage, and if a dc path is provided, current will flow during the positive half cycles. This current injects a charge into the diodes, which lowers the diode resistance, causing some portion of the incident power to be reflected and some portion to be absorbed in the diodes.

During the negative half cycle the stored charge remains in the diodes, at least for some portion of this half cycle (exactly *what* portion depends upon the lifetime of the diode and the frequency). As shown in Figure 26, this serves to illustrate two important characteristics of diode limiters. First, for a given diode lifetime there is some frequency below which the stored charge will remain for only a negligible portion of the negative half cycle; the result would be a limiter with a maximum of 3 dB limiting. Second, the output waveform of a limiter is not symmetrical; therefore harmonic and intermodulation distortion levels are high. This applies both to the power that is transferred to the load and to that which is reflected to the source.

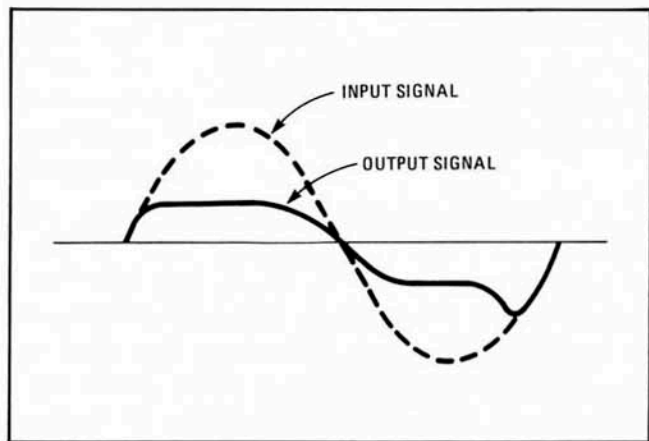

Figure 26. Limiter Action.

Because the limiter is a reflective component, other mismatches in the circuit must be considered in the same way that they are considered with reflective switches, and the discussion in Section IV-D applies equally to limiters. In addition, the high level of harmonics generated in a limiter makes it necessary to consider the effects of mismatches at harmonic frequencies.

Although the two limiter diodes are in shunt, the current is not the same in each diode. The RF power, of course, is greater at the diode nearest the source, and the dc voltage is not completely equal-

ized because of the diode series resistance. One result of this unequal biasing is that the phase vs. attenuation characteristics of a limiter are different from those of a two-diode switch. This also restricts practical limiters to two diodes, because more diodes add almost no additional attenuation.

For most efficient limiting, the dc resistance of the dc return should be 1 ohm or less. Higher values do not change the threshold, but they do change the slope, as illustrated in Figure 27.

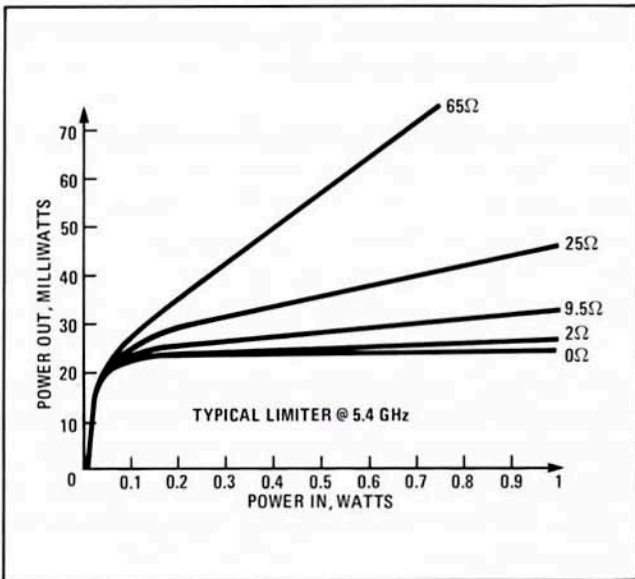

Figure 27. Limiting vs. dc Return Resistance.

#### C. Limiter Response to Fast Pulses

The attenuation of a limiter is dependent upon the input power, so input power must be stated when specifying attenuation. A convenient measure of limiting is the maximum output power for a given input power; this is called leakage. Leakage is specified in two ways — flat leakage or spike leakage.

Flat leakage is the steady state output power for a given input power. Typically flat leakage is specified at 1 watt for CW applications and at 75 watts for pulse applications. Spike leakage is the initial surge of power that gets past the limiter when the input pulse rise time is faster than the switching speed of the limiter. Spike leakage, which is measured in ergs, and flat leakage both are illustrated in Figure 28.

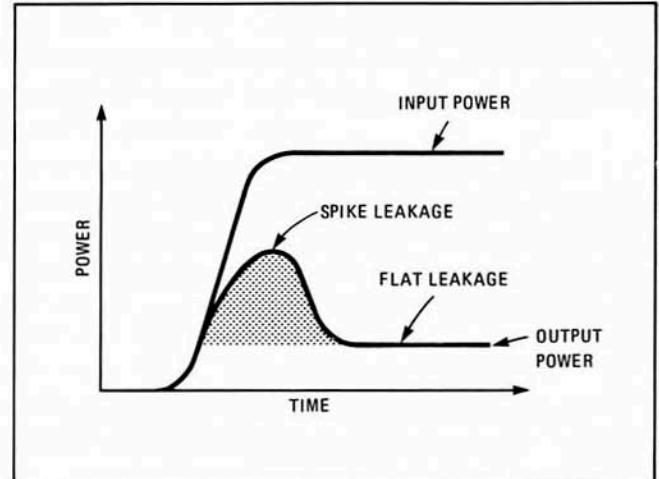

Figure 28. Spike Leakage and Flat Leakage.

#### D. Changing Limiting with dc Bias

The threshold of a limiter can be adjusted both above and below its normal level by applying a bias to the diodes. This is illustrated in Figure 29. The cost is some level of dc power lost, because the resistance of the dc return must remain low if the limiting slope is to stay flat, and the voltage must be developed across this low resistance. In some cases a tradeoff can be made. The threshold and the slope adjustments are independent, allowing the designer to tailor the limiter characteristics for specific applications.

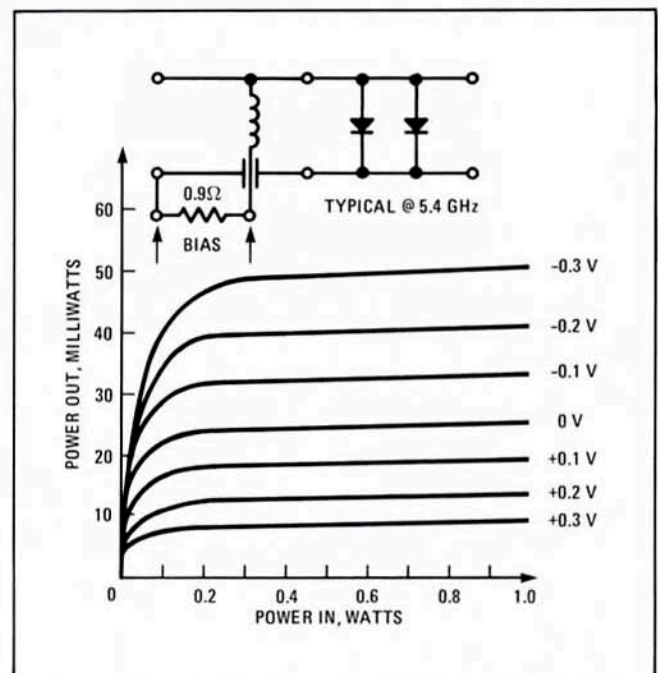

Figure 29. Limiting vs. Bias.

## VII. USING MODULES

### A. General Considerations

For large-volume OEM systems there are some significant advantages in using modules for switching and limiting applications. Considerable cost savings are combined with the opportunity to design optimum circuits and integrate many functions in a space- and weight-saving subsystem.

However, the successful integration of modules requires thorough engineering. There are several areas of particular concern:

1. RF leakage, either through the transmission line structure or through associated circuitry, can be difficult to control when the dynamic range is large and the frequency is high. If the system is to be operated over a wide temperature range, the problem is compounded. Differential thermal expansion causes a small gap, often only a few ten-thousandths of an inch, to appear as a resonant section of line whose path attenuation is significantly less than a multidiode switch in the OFF condition. The solution is careful mechanical design, as well as thorough prototype testing over the entire environmental range. The latter is very important.

2. Transitions must be carefully designed so that the inherent low insertion loss and good match of the modules will be realized over the band of interest.
3. The mechanical mounting of the modules should be designed in such a manner that they may be easily installed by production workers without damage. It is also very desirable to be able to remove modules without damage, so that if necessary they can be independently tested for troubleshooting and fault verification.
4. The modules should be properly heat sunk for higher power applications.
5. Bias and blocking networks must be designed.

### B. Coaxial Systems

There are many acceptable methods for mounting coaxial modules. The choice is often dictated by other RF circuitry, or by the size and type of transmission line. Several examples are shown in Figure 30; some of the design considerations are discussed below.

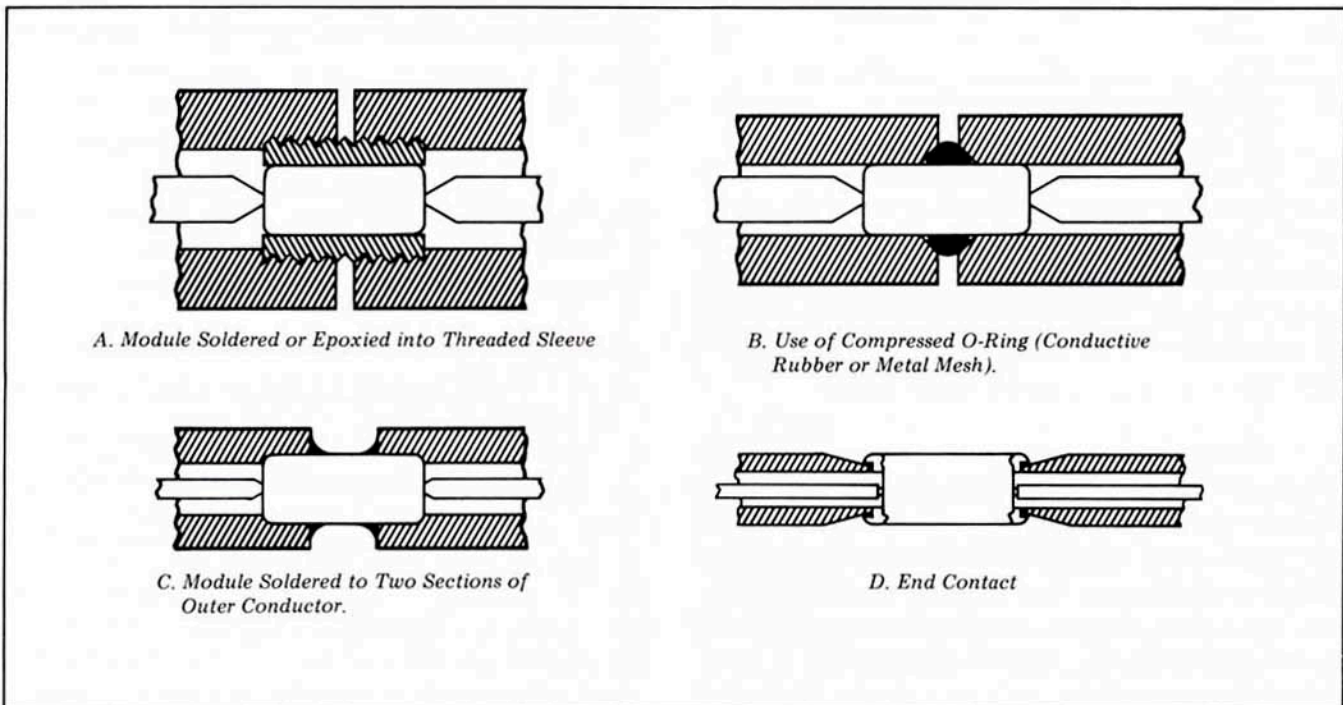

Figure 30. Examples of Methods used to Mount Coaxial Modules.

The prime requirement is that a good dc contact and a tight RF seal be maintained over the environmental range. Since gaps on the order of 0.0001 inch may cause leakage, and the thermal expansion of the kovar module is usually different from that of the rest of the system, this precludes simple metal-to-metal contact such as inserting the module into a tight hole. The end-contacting method shown in part D of Figure 30 requires a constant contact pressure, which is not easily designed into systems that will encounter wide temperature ranges. End mounting also is a poor heat-sinking arrangement for the module.

One solution is to use solder or conductive epoxy, which will completely solve the leakage problem. If the module is mounted directly into the transmission line as shown in C of Figure 30 it is difficult to remove it for replacement or troubleshooting. Another method is to solder or epoxy the module into a carrier, such as the threaded sleeve shown in A of Figure 30. If the carrier is of the same material as the rest of the transmission line, assembly techniques such as the one illustrated will maintain a tight RF seal over a wide temperature range.

The modules will withstand temperatures of up to 230°C for a reasonable period of time, which allows the use of most common soft solders. Careful control of production processes is necessary to avoid overheating. For this reason, epoxy is recommended. The following specifications have proven very successful for mounting modules into carriers:

- Carrier material: brass, 0.0002 in. silver-plated
- Hole diameter: 0.188 in. + 0.002-0.000 in.
- Epoxy: Eccobond solder 56-C with Catalyst # 9

Another solution involves the use of compressible conductive material. Many varieties are available in either wire mesh or conductive rubber. Part B of Figure 30 shows a typical example using a conductive O-ring.

The transmission line center conductor is usually soldered to the center conductor of the module. A small solder insertion hole is drilled into the center conductor as shown in Figure 31. Resistance soldering tools work well in this application.

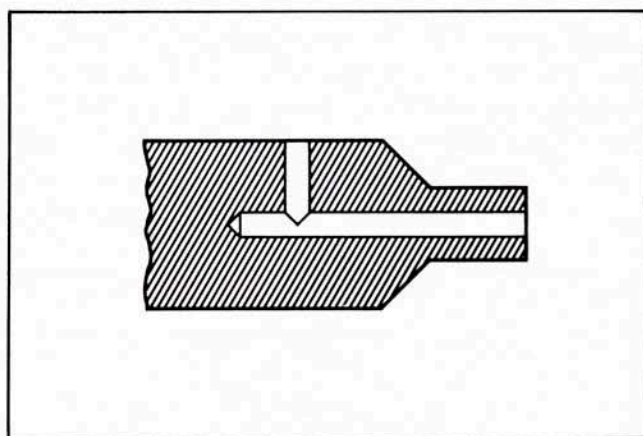

Figure 31. Center Conductor Details.

Another method is to form a beryllium copper center conductor into a collet to contact the module wire.

Three transitions to common transmission lines are shown in Figure 32. These transitions maintain electrical integrity through 18 GHz.

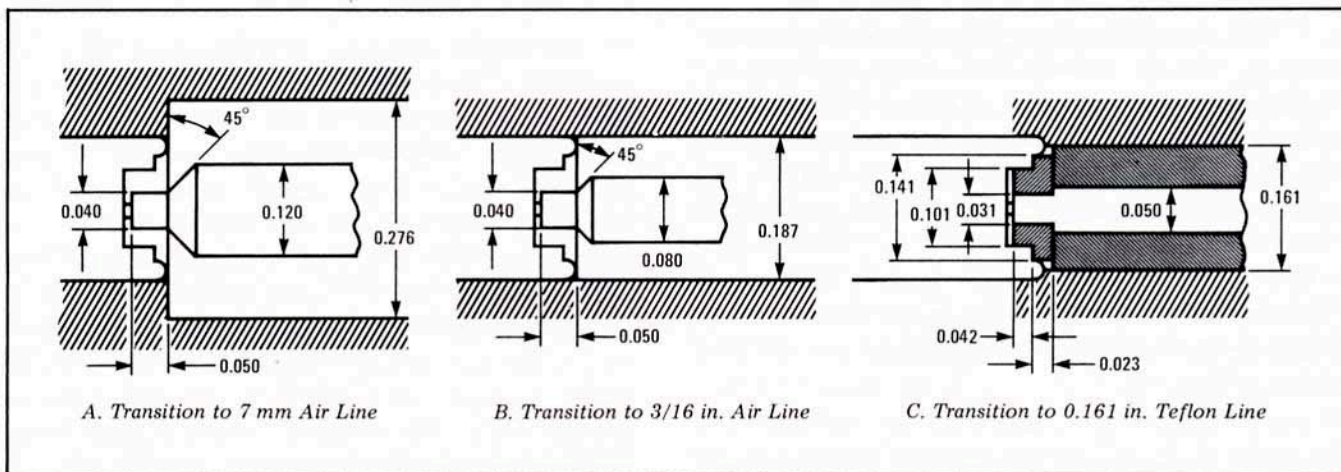

Figure 32. Typical Transitions.

### C. Waveguide Systems

Complete switches can be combined with waveguide-to-coaxial adapters to form switches suitable for use in waveguide systems, or modules may be integrated directly into waveguide systems with the same economies and advantages as in the case where modules are integrated into TEM systems.

Figure 33 shows two waveguide switches that utilize integrated coaxial modules. The loop coupling scheme is satisfactory for narrowband ( $\leq 20\%$ ) systems.

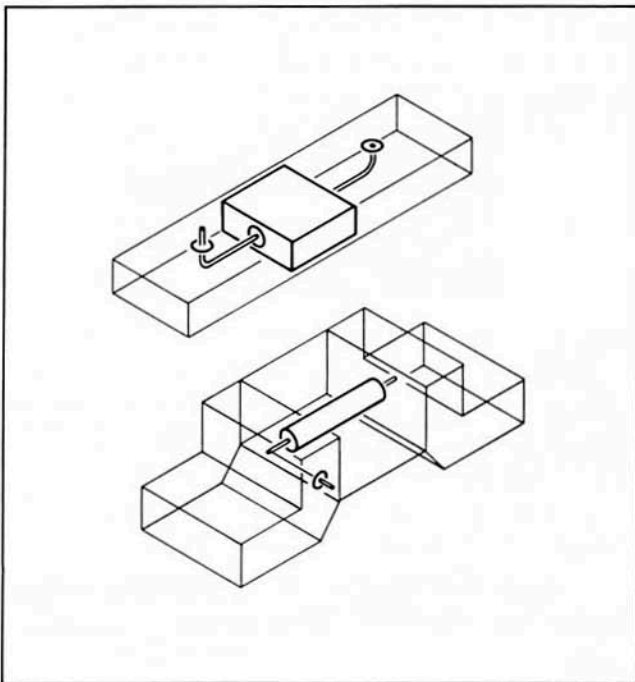

Figure 33. Waveguide Switches Using Modules.

### D. Strip Transmission Line Systems

The mounting of stripline modules depends upon the specific package style. Some packages are designed to be mounted in recesses milled into the ground planes of 1/8 in. stripline; others are designed to sandwich between the ground planes. In order to obtain satisfactory performance, a gap-free contact between the module and both ground planes is an absolute necessity, and it must be maintained over the operating temperature range of the system. Metal mesh contacts are commonly used to achieve this objective.

The center conductor may be soldered to the stripline center conductor or, when dielectric is used

on both sides of the center conductor, the pressure of the dielectric may be used to hold the wires in place.

Transitions from the module to stripline depend upon the specific dimensions and the dielectric constant. A typical transition is shown in Figure 34.

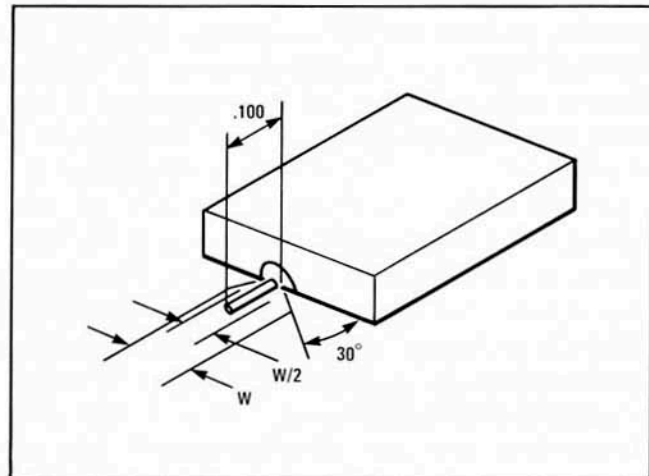

Figure 34. Stripline Transition.

Because of the open construction of strip transmission line, high values of isolation are difficult to achieve without leakage. For systems which must operate reliably over a wide temperature range, about 50 dB is the practical limitation for a single module. When greater values of isolation are required, more than one module can be used, with some reasonable spacing between the modules. When possible, it is good practice to separate the circuit into two sections with solid metal between them. The metal divider can be bored and a three- or four-diode coaxial module can be inserted.

### E. Bias Circuits

All of the switching modules discussed in this application note are unbalanced; i.e., the control signal must be applied to the RF transmission line. Accordingly, some circuits must be added to separate the bias and RF signals. These circuits are filters and separate the two signals according to their frequencies; in the applications discussed here the frequency of the RF signal is higher than that of the control signal, whose bandwidth extends down to dc. The two major components of the bias circuitry are the *bias network* (often called the dc return), which introduces the control signal to the RF line, and the *dc block*, which prevents the bias from impinging on the rest of the RF circuit.

The primary design considerations, other than the normal concerns for size, weight, cost, etc., are as follows:

1. *RF Bandwidth.* The bias network and the dc return should have a minimum insertion loss in the RF passband.
2. *Video Bandwidth.* The bias circuitry should have flat response to the control signal, reproducing modulating signals or pulses without rolloff or ramping.
3. *Delay.* The circuits should contribute a minimum delay to the control signal.
4. *Video Leakage.* The level of the video or pulse signal that appears on the rest of the RF circuit should be kept to a minimum.
5. *RF Leakage.* The leakage of RF power through the bias port should be minimized.

Most bias networks are simple two-element filters that use lumped and/or distributed elements, as shown in Figure 35. RF chokes are used when the RF bandwidth does not exceed 2 GHz or 3 GHz and must extend to low frequencies. Video bandwidth suffers accordingly. The most common combination is a quarter-wave stub and a bypass capacitor. The RF bandwidth is extended by making the impedance of the stub higher than that of the RF line. Good performance over one or two octaves can be obtained with physically realizable impedances, and this can be extended using techniques described below.

Helical or spiral lines can be used to construct quarter-wave stubs; this technique reduces the physical dimensions and at the same time increases the impedance. The bypass capacitor serves two purposes — it establishes the RF short which is transformed by the stub, and it further isolates the RF from the bias port. Good RF performance and bias port isolation on the order of 25 dB can be obtained if the bypass reactance is less than 5 ohms. Further reduction of this value will have a detrimental effect on the video bandwidth and delay; if high levels of bias port isolation *and* fast switching are required, additional filter sections, such as those optionally available in the 33200 series switches, are suggested.

The dc block is ordinarily a single element, either lumped or distributed, as shown in Figure 36. The prime object is to keep the control signal from the rest of the RF circuit and, conversely, to keep any other video signals that might be present from the diodes. Another important consideration, however, is to present an open circuit to the video. If the capacitance is excessive both switching speed and delay will be affected.

Lumped element dc blocks are particularly useful for multioctave bandwidths. The distributed version can be used for bandwidths up to about two octaves, the bandwidth being an inverse function of the quarter-wave stub impedance. If the RF bandwidth is narrow, the stub impedance can be increased, which results in very effective suppression of video leakage.

Bias circuits covering one or two octaves are easy to achieve, but those which operate over very

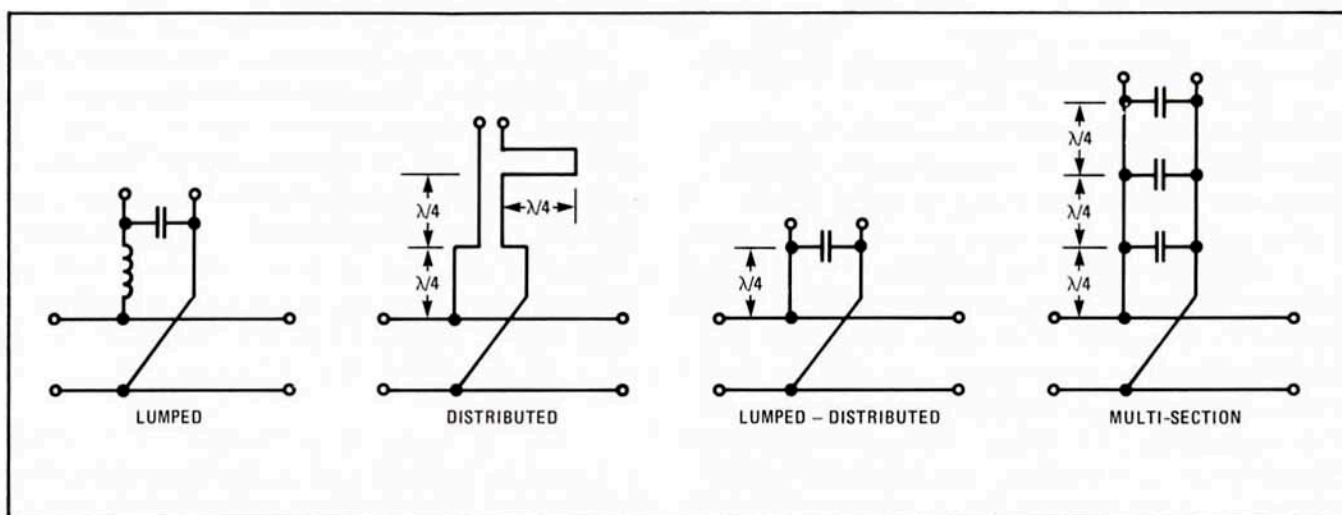

Figure 35. Bias Networks.

wide bandwidths pose formidable problems in design. The multiwavelength damped stub used in the 33100 series switches is one example. High-pass filters in the form of T or  $\pi$  networks can be constructed using lumped elements mounted in a transmission line structure. The upper frequency limit is governed by parasitic reactances of the lumped elements and their associated mounting structure; careful design and manufacturing can extend the frequency range to at least 12 GHz.

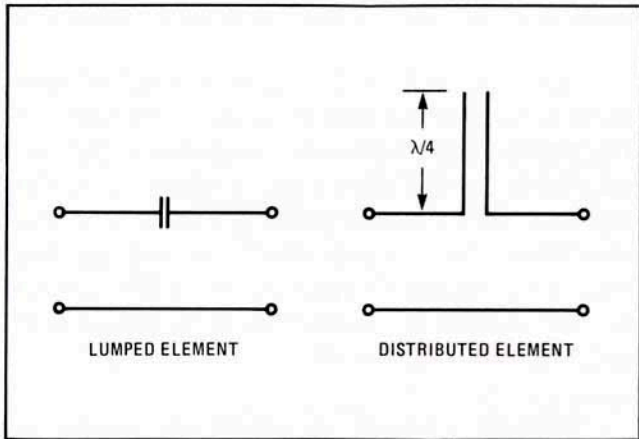

Figure 36. DC Blocks.

Simple filter techniques can be used to extend the bandwidth of bias circuits to more than a decade. One technique is to use a quarter-wave open series stub, which will serve as the dc block, to extend the bandwidth of the quarter-wave shorted shunt stub used in the bias network. The shunt stub characteristic impedance should be made as high as possible, and the characteristic impedance of the series stub should be:

$$Z_{\text{series}} \text{ (normalized to 50 ohms)} = \frac{K}{1 + K^2 \cot^2 \beta \ell} \quad (2)$$

where K is the normalized characteristic impedance of the shunt stub and  $\beta \ell$  is the electrical length of either stub at the high or low edge of the band.

Impressive results can be obtained with physically realizable impedances. Calculations for an 11:1 bandwidth show that with a 250 ohm shunt stub (easily achieved in air dielectric coaxial line), band edge VSWR is 2.15:1; adding a 6.4 ohm series stub reduces this to 1.56:1. Using a 500 ohm shunt stub, which can be done with a helical line, the VSWR without a series stub is 1.45:1; with a 4.4 ohm series stub the VSWR is 1.14:1.

The designer should not overlook existing system components to serve as all or part of the bias circuit. Sections of waveguide, highpass or bandpass filters, or any other components with a high degree of rejection of lower frequencies may be used as dc blocks if they appear as a very high impedance to the video signal.

Many components can serve as bias networks. Loop-coupled filters, antennas, or waveguide adaptors can be used simply by lifting the loop off ground with a bypass capacitor. Terminated ports in components such as circulators and couplers can be used if the port is dc coupled to the switch; a lossy dielectric load is used and the control signal is introduced through the load, which has little or no effect on the low frequencies.

## VIII. SWITCHING CIRCUITS

### A. Shunt Mode SPNT Switches

For applications where the bandwidth does not significantly exceed one octave, shunt mode multithrow switches will provide excellent performance. Figure 37 illustrates a shunt mode SPDT switch using stripline construction. Higher isolation can be obtained by adding modules or by using four-diode modules in a coaxial structure.

At the center frequency, the OFF arm appears as a quarter-wave shorted stub in shunt with the line. At frequencies above or below this center point the stub becomes longer or shorter than a quarter wavelength, adding reactance and causing reflections; this limits the usable bandwidth of this type of switch.

There are at least two methods which can be used to improve the bandwidth of this circuit. One is to use a quarter-wave open series stub, as shown in Part A of Figure 38. The characteristic impedance of the series stub should be determined using equation (2) in Section VII-E; note that the optimum impedance depends upon the bandwidth. As an example, the optimum series stub impedance is 37.5 ohms for a one-octave bandwidth, improving the band edge VSWR from 1.77:1 to 1.33:1.

Another technique is illustrated in B of Figure 38. The impedance of the quarter-wave section between the junction and the first diode is reduced in both arms. Now, in addition to the quarter-wave

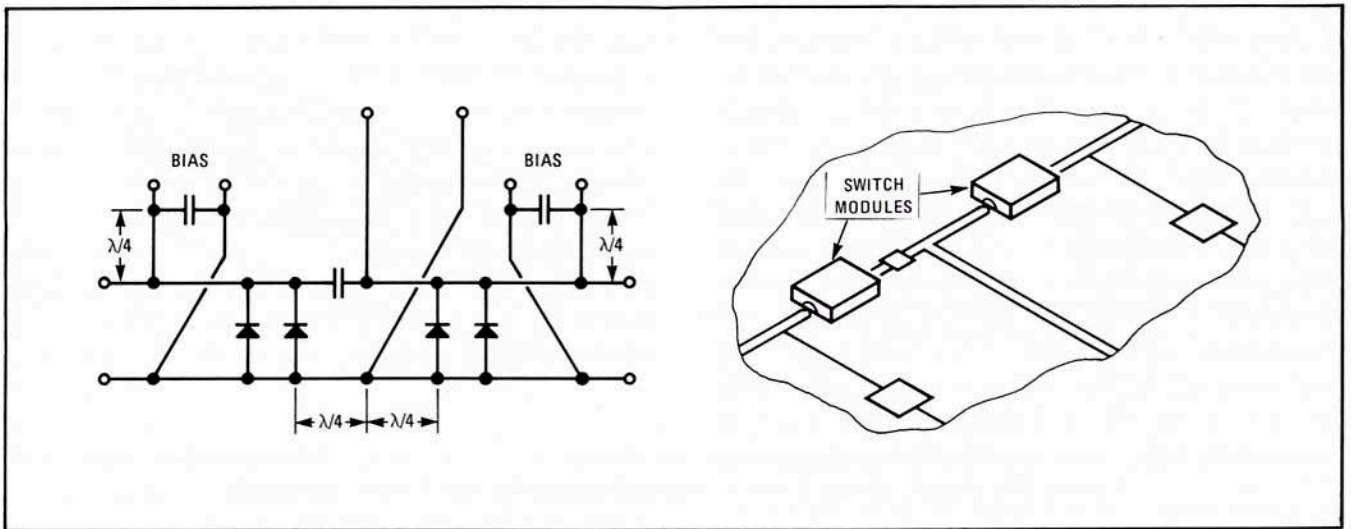

Figure 37. Shunt Mode SPDT Switch.

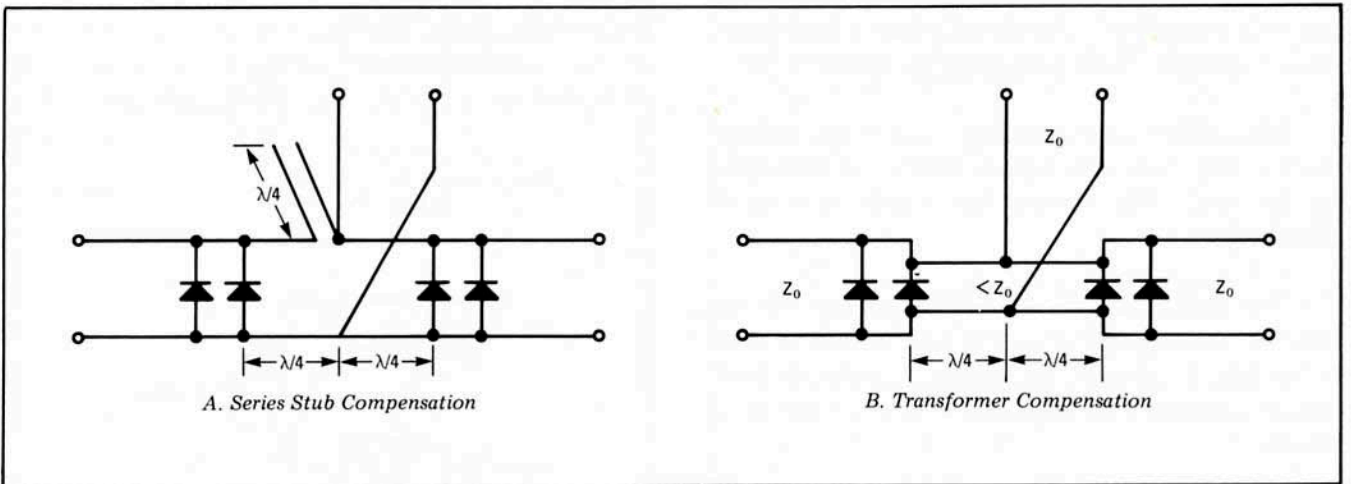

Figure 38. Compensated Shunt Mode Switches.

stub presented by the OFF arm, a quarter-wave transformer is introduced to the circuit. As in the above technique, the optimum impedance is a function of the required bandwidth.

At higher frequencies it is often physically difficult to get the diodes close enough to the junction to achieve quarter-wave spacing. One restricting factor is the dc block which is required in one arm to enable separate biasing in each arm. There are two ways to eliminate this block. One is to use diodes of opposite polarity in the two arms, but this has several drawbacks. For example, diodes with opposite polarity usually have different characteristics. Also, the diodes will be connected in such a manner that a reverse bias greater than 0.7 or 0.8 volt cannot be applied; this gives rise to the

rectification and slow switching problems mentioned in Section V-B, and the convenient solution of using a resistor is not applicable here.

The second solution is to isolate the modules from ground and apply bias to the outer conductor. An example of this is illustrated in Figure 39. The limiting factor is the distributed capacitance required between the module and ground; for a two-diode module this is 200 to 300 pF. For three- or four-diode modules the capacitance required is not realizable, but more than one module can be cascaded in the arm.

One practical method of achieving the necessary capacitance is to use an anodized aluminum sleeve. A very thin (less than 0.001 inch), hard

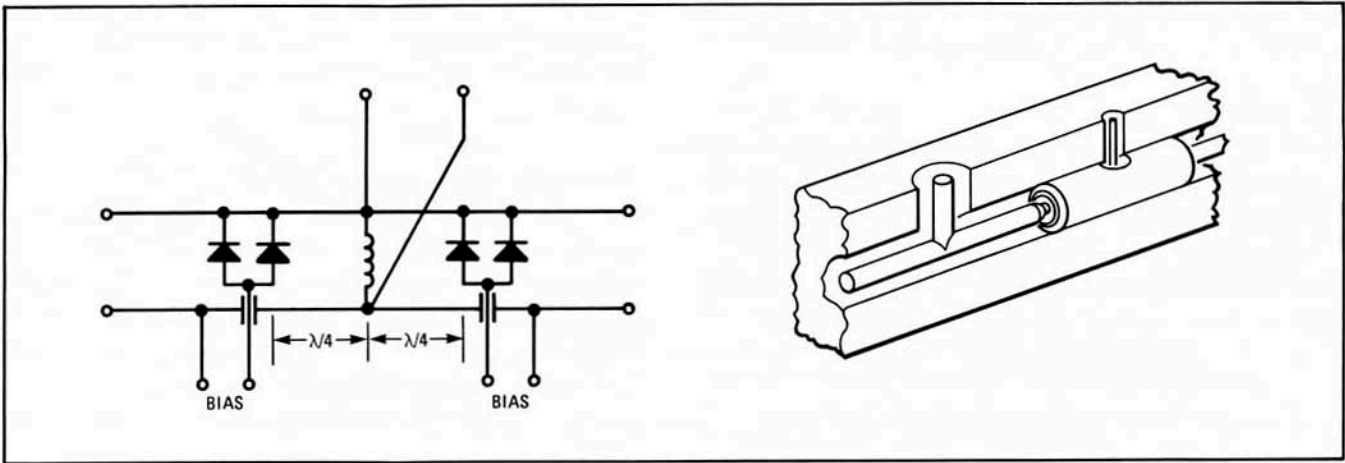

Figure 39. Shunt Mode Switch with Modules Isolated from Ground.

anodized film, coupled with an air gap not exceeding 0.0002 or 0.0003 inch, will meet the requirement. This requires tight manufacturing tolerances, but it results in a rugged and reliable component.

If quarter-wave spacing cannot be accomplished, any odd number of quarter wavelengths can be used. The usable bandwidth is reduced accordingly.

The techniques illustrated were for two-throw switches, but there is no limit to the number of arms in this type of switch. Bandwidth is reduced, however, in approximate proportion to the number of throws.

Although shunt-mode switches are ordinarily constructed with coaxial or stripline modules, in the UHF region they may be assembled easily using complete switches such as the 33100 series, T-junctions, and appropriate lengths of cable.

#### B. SPNT Switches Using Circulators

Multithrow switches can also be constructed using SPST switches and circulators as shown in Figure 40. The bandwidth of the switch is limited to that of the circulator, which is usually an octave or less. A noncritical circuit, it can be assembled by connecting complete components or it can be a coaxial or stripline integrated component.

The isolation and switching speed are those of the module, since the circuit presents no limitation to these parameters. The distance between the switches and the circulator is not important except as it pertains to line loss. The circulator typically

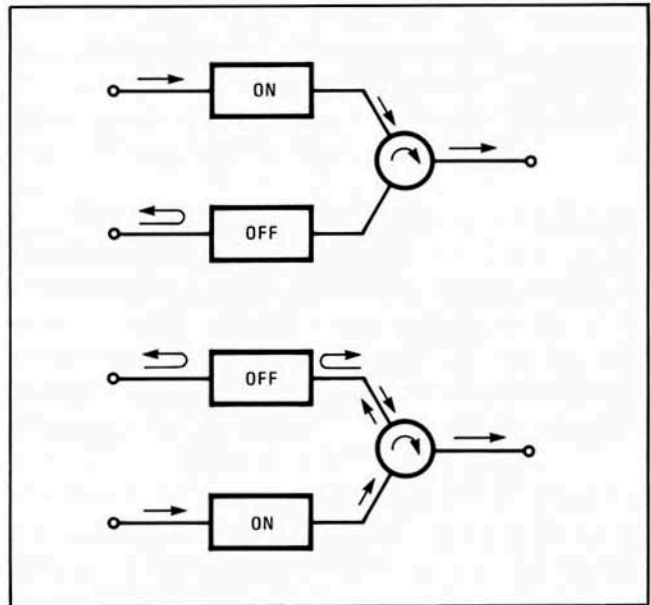

Figure 40. Multithrow Switches using Circulators.

adds very little additional insertion loss. The insertion loss is not the same in both arms, and this is one application where reflection loss of the switch is significant.

#### C. Multithrow Circuits

A number of multithrow circuits are illustrated in Figure 41. Part A of Figure 41 shows the use of SPDT components to construct SPNT switches; N-1 SPDT's are required.

SPDT switches can also be constructed using quadrature hybrids. In B of Figure 41 the isolation of Port 1 is limited to the directivity of the hybrid, which is typically 20 dB. In C of Figure 41 another switch is added to solve this problem.

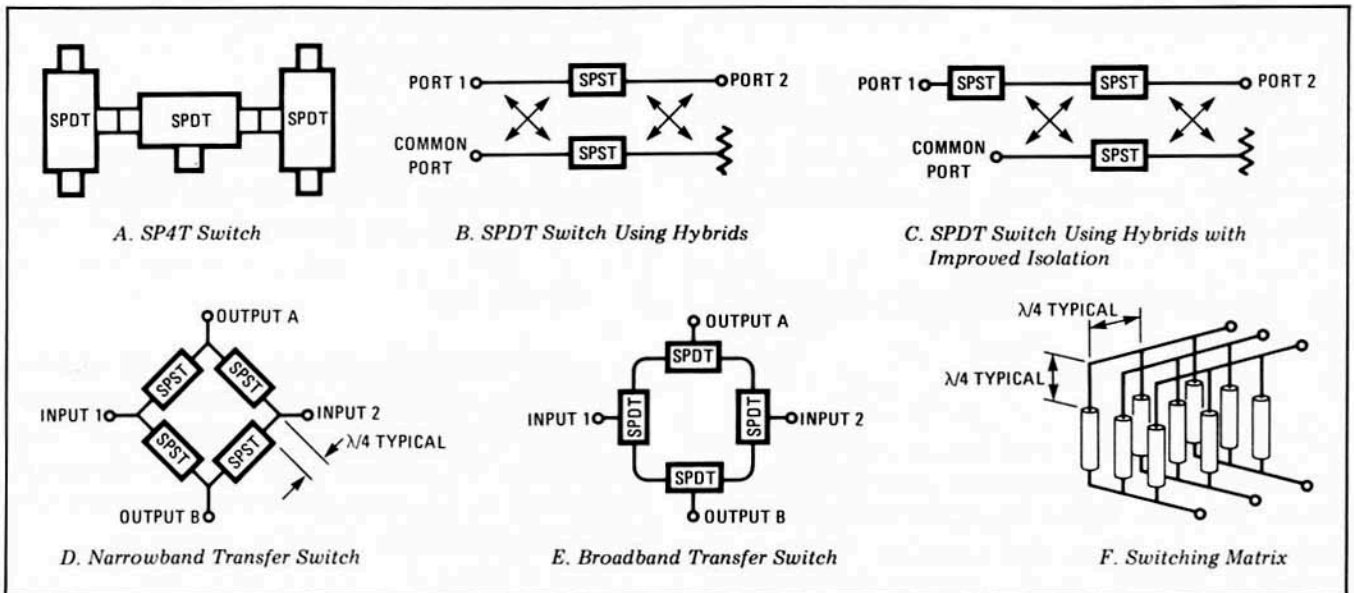

Figure 41. Multithrow Circuits.

Transfer switches have two inputs which are alternately switched to two outputs. A typical application is radio hot standby, where two transmitters are operating, with one connected to the antenna and the other to a dummy load. Two versions of transfer switches are shown in D and E of Figure 41.

Modules can be used to construct rather complex switching circuits, such as the matrix shown

in F of Figure 41, which can switch any one of N inputs to any one of M outputs. Because of the many stubs in the circuit, components such as this are usually quite narrowband.

D. Absorptive Circuits

Figure 42 illustrates some of the many absorptive circuits that can be constructed with switches or switch modules.

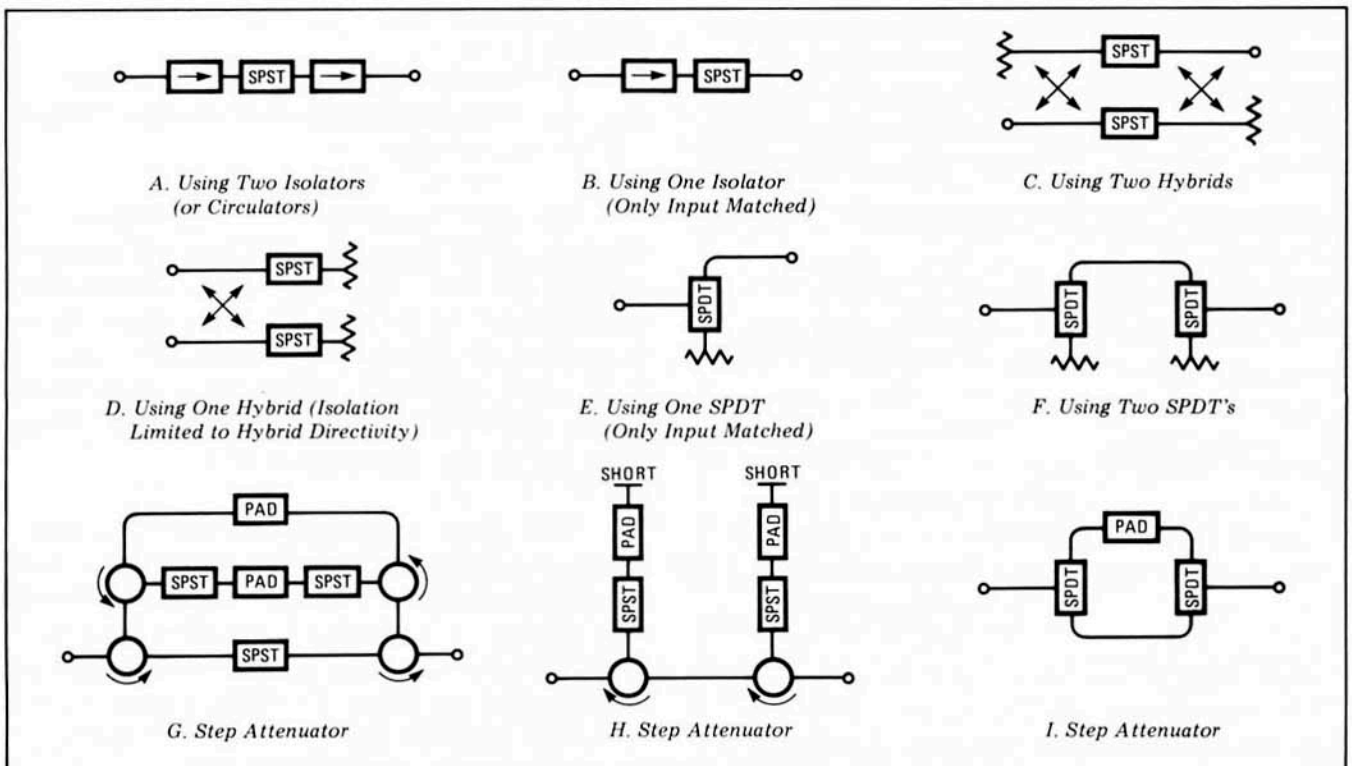

Figure 42. Absorptive Circuits.

## E. Digital Phase Shifters

Switches can also be used as the basic building block in digital phase shifters; this is illustrated in Figure 43. Note that the circuits and techniques are similar to those used for multithrow and absorptive circuits.

## IX. MEASURING SWITCHES AND LIMITERS

### A. VSWR and Reflection Loss

VSWR and reflection loss are, of course, the same thing, and are measured on the same equipment. The two terms are used to indicate the operating conditions, and therefore the level of reflection. VSWR refers to low-level reflections, such as those measured with absorptive components or reflective ones in the ON condition; reflection loss is the same parameter measured when a reflective component is OFF.

Both of these measurements are straightforward and are made using reflectometers or network analyzers. The only special consideration is that the wrong combination of RF power, bias circuit impedance, and bias level may cause rectification, resulting in an erroneous measurement. When measuring ON condition VSWR, the bias terminal should be either open circuited or reverse biased if the incident power is high enough to cause the diodes to rectify. (This level depends upon the type of diodes and to some extent the frequency; safe levels are +10 dBm for high isolation diodes and 0 dBm for fast switching diodes.) Limiters should be

measured with the dc return in place and the power level no greater than 0 dBm.

OFF condition reflection loss should be measured with enough forward current to saturate the diodes thoroughly. Reflection loss will be minimized, and diode rectification will be prevented.

### B. Insertion Loss

ON condition insertion loss of diode switches and limiters is another straightforward measurement, using standard microwave techniques and equipment. The precautions regarding rectification mentioned in the preceding section apply equally to this measurement.

One other consideration is diode heating. If the incident RF power is several hundred milliwatts or higher, some diode heating will take place; even though rectification may be prevented by reverse bias or open circuit bias, the diode heating will cause the insertion loss to increase. The increase is small, on the order of 0.1 dB with 1 watt of incident power.

### C. Isolation

Measuring the OFF condition isolation of switches with any degree of accuracy is more difficult than one might expect. There are two main problems:

1. The wide dynamic ranges to be measured.
2. The large mismatch errors possible with reflective switches.

The measurement of a dynamic range of, for example, 80 dB requires either high RF power or sensitive detection equipment. High power is obviously limited by the power handling capability of the switch; in addition, high input power can be used only for full OFF measurements, since rectification will occur if the switch is biased to an intermediate level (see Section IV-L).

With these restrictions on the input power levels, simple detectors are often hard pressed to detect signals which are attenuated by 80 dB or more. The solution is to employ a spectrum analyzer or similar receiver detection system. With sensitivities of typically greater than -125 dBm, a spectrum analyzer will allow the use of modest input power, yet it will afford a high-resolution, noise-free readout. The automatic network analyzer also has the sensi-

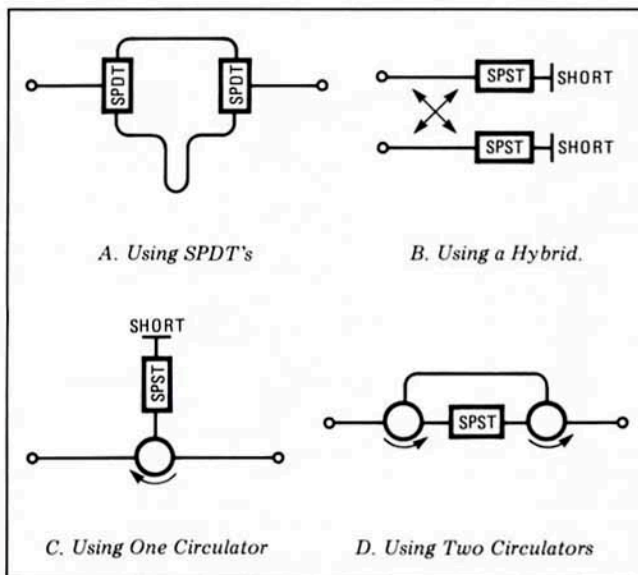

Figure 43. Digital Phase Shifters.

tivity required to make this kind of measurement

Another problem encountered when measuring wide dynamic ranges is RF leakage in the measuring system. This is usually easy to detect and eliminate, *if* someone is looking for it. In many cases, however, leakage paths appear after a measurement setup is calibrated and checked out, and the resulting read-out is improperly interpreted as a faulty switch.

Also, leakage paths may be encountered when modules are integrated into a larger component or system and the complete assembly is being tested; low isolation readings may be the result of leakage within the assembly rather than the module. Fortunately, it is easy to determine if the problem is leakage. The inherent isolation vs. frequency characteristic of this type of switch is very smooth; if the measurement system is well matched the isolation viewed over a wide frequency range either will be flat or will exhibit the normal increase with frequency, with no significant ripple. Most leakage paths, on the other hand, are resonant and appear as narrowband glitches on a swept measurement.

In the rare case where the leakage path is not resonant, the transmission phase through the leakage path will be different from that through the switch. If the bias is adjusted to the point where the switch isolation is about equal to the isolation of the leakage path, a swept display will show large variations in isolation as a function of frequency. (Remember that the RF power must be below the rectification level if the bias is set below saturation.)

The problem of mismatch errors has been discussed in Section IV-D; here it has been shown that relatively small mismatches can cause significant changes in isolation of a reflective switch. When measuring the switch, these changes result in measurement errors.

An automatic network analyzer system, if available, will eliminate mismatch errors by measuring the magnitude and phase of the mismatches and subtracting the associated errors from the read-out. For systems that lack this capability, the use of low VSWR isolators or circulators usually reduces the error to an acceptable level. Padding with attenuators is not practical because of the dynamic range being measured (attenuators further reduce a signal which is already difficult to measure).

The absorptive modulator is not a reflective

device, so the mismatch errors encountered in measuring these components are not significant.

The dynamic range problem is not a factor in measuring limiter isolation; compared to switches the dynamic range of a limiter is fairly small, and of course input power is a parameter of the measurement. Mismatch error is a factor, and is treated in the same manner as with switches.

Limiter attenuation measurements do present one unique problem — that of harmonics. As discussed earlier, limiters generate significant harmonics when the RF power level is above threshold. When measuring limiting, the frequency response of the system that will use the limiter should be considered, *and if possible the measurement system should duplicate that response*. The possibility of circuits resonant to a harmonic frequency should be considered, both in the end system and in the measurement setup.

#### D. Switching Speed

The measurement of switching speed is not particularly difficult, but there are certain important considerations which are unique to this measurement. The basic components of a setup for measuring switching speed are shown in Figure 44.

Switching speed measurements are always made at single RF frequency, so the RF source does not need a swept output. The power level should be relatively high, because this will improve the RF/pulse ratio and thus simplify the problem of filtering the switching transient from the display. The limitation on the amount of power that can be applied is determined by the detection and display

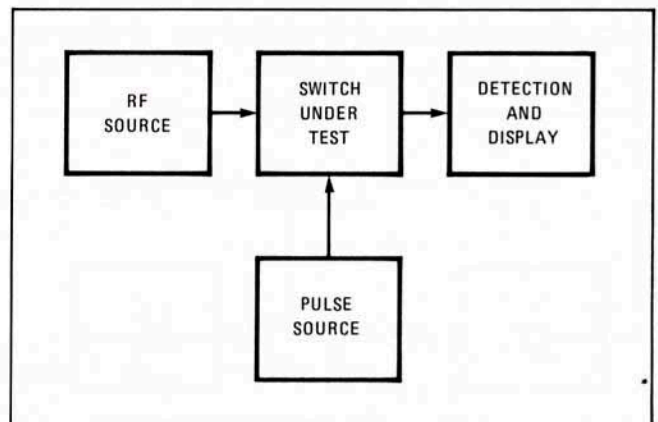

Figure 44. Basic Switching Speed Measurement Setup.

components, the saturation level of a sampling scope or the square law response of a detector.

The RF source should be well isolated from the switch by a pad or ferrite isolator. Besides the requirement for a good match to the input and output of the switch (discussed below), if the source is leveled its leveling loop may be confused by any reflected pulses, causing pulse modulation of the source itself.

The pulse source can be any suitable switch driver, such as the one illustrated in Figure 18. Since the switching speed of a diode switch is very dependent upon the driver and bias circuits, it is advisable to duplicate in the measuring setup the system in which the switch will ultimately be used.

A convenient driver for a bench measuring setup can be made by combining a pulse generator and a dc power supply. The power supply sets the steady state current to bias the switch OFF, and the pulse generator pulses the switch ON. The two components must be combined in such a manner that the dc is not shunted across the pulse generator and the pulse is not shunted across the power supply. A method for achieving this is shown in Figure 45; the value of the capacitor and inductor are determined by the required pulse width.

The pulse generator voltage should be adjusted to not more than 50% of the diode breakdown voltage, because when the stored charge is cleared from the diode its impedance goes to several thousand ohms, thereby doubling the indicated voltage.

There are two methods for detecting and displaying the RF pulse. One is to terminate the RF with a diode detector and display the output on an oscilloscope. The other is to feed the RF directly into a sampling scope synchronized to the pulse

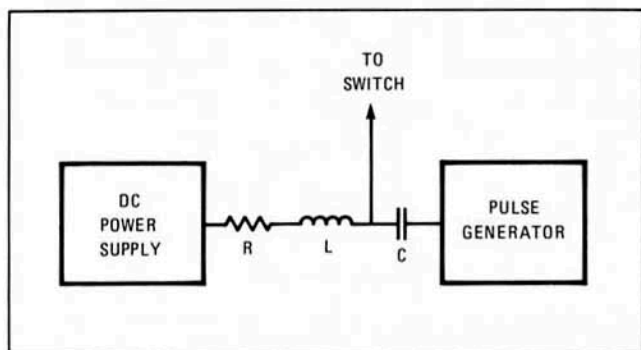

Figure 45. Bench Driver Circuit.

rather than the RF. The detector/scope combination is less expensive and is entirely suitable for measuring 10 - 90% switching speeds which are slower than 20 ns. The sampling scope is required for faster switching measurements, and its significantly greater dynamic range (because it displays linear voltage rather than square law response) prescribes its use in wide-range switching measurements.

As mentioned in an earlier paragraph, the switch must see a good match at both its input and output. If not, at the moment the switch shuts off a resonant circuit will be formed by the switch and any external mismatch. Power will be reflected back and forth, decaying at a rate determined by the resonant line length and the reflection coefficient of the offending mismatch. If this decay rate is slower than the rate at which the switch turns off, the display will be distorted.

In order to minimize this effect, the system should be well matched over a bandwidth consisting of the RF signal plus its switching sidebands. Then the entire RF line should be made as short as possible. If a 90 - 10% measurement is required, reasonable care will completely eliminate any distortion of the display.

Dc blocks must be provided at both ports of the switch. At the generator end a normal blocking capacitor will do, since the only requirements are that a high impedance be presented to the pulse and that the pulse should not appear at the source and possibly affect the leveling loop.

At the load end the requirements are usually more stringent. Any pulse that arrives at the detector or sampling scope will appear on the display, masking the true rise and fall time of the RF pulse. Common practice is to use a short section of waveguide (typically two waveguide-to-coax adaptors, back to back) as a high-pass filter; this completely eliminates the problem.

A typical setup for measuring switching speed is illustrated in Figure 46.

Thus far, only switching measurements covering the 10 - 90% region have been discussed. However, upon occasion it becomes necessary to measure switching speed over a much greater dynamic range. Such measurements can be made with varying degrees of difficulty. A 40 dB range measurement is relatively simple, and can be made on the setup

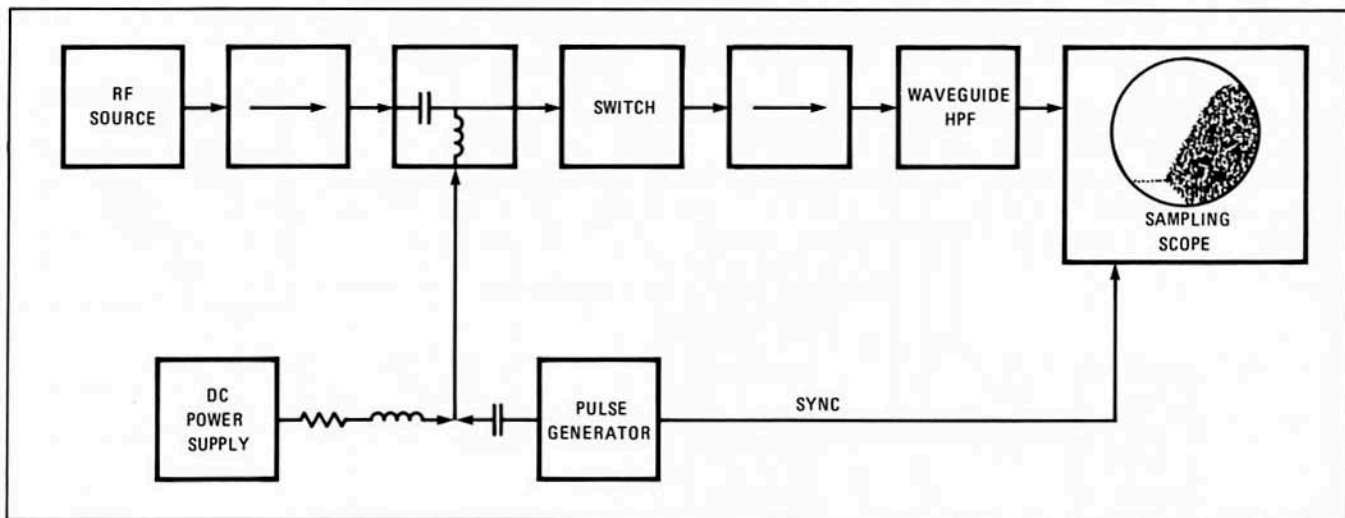

Figure 46. Typical Setup for Measuring Switching Speed.

shown in Figure 46. The RF power should be adjusted so that the sampling scope is not quite saturated, which is about +10 dBm incident to the scope. If the vertical gain is expanded so that the height of the display is several times that of the scope face, the 1% level (which is 40 dB on a linear voltage display) can be read fairly easily. The measurement requires two steps. A horizontal reference mark must be made at the 1% point (or the horizontal position adjusted to coincide the 1% point with a particular reference line) and the vertical position must then be adjusted until the top of the pulse becomes visible. The switching time is measured from the reference mark or line to some point (for example, 95%) on the top of the pulse. This is illustrated in Figure 47.

The measurement just described was from OFF

to ON; the ON to OFF measurement is made in exactly the same manner. For this measurement, however, impedance matching becomes more critical, particularly between the switch and the sampling scope.

Beyond 40 dB, special setups are required. OFF to ON can be measured over the entire dynamic range of the switch by inference. Referring to the setup shown in Figure 48, a broadband T-connector is located at the bias port of the switch, and a small portion of the bias pulse is coupled off and injected into the second channel of the sampling scope. The length of the cable between the T-connector and the sampling scope is carefully adjusted so that its calculated delay is equal to that from the switch to the sampling scope. What will be observed on the scope face will be the interval between the time

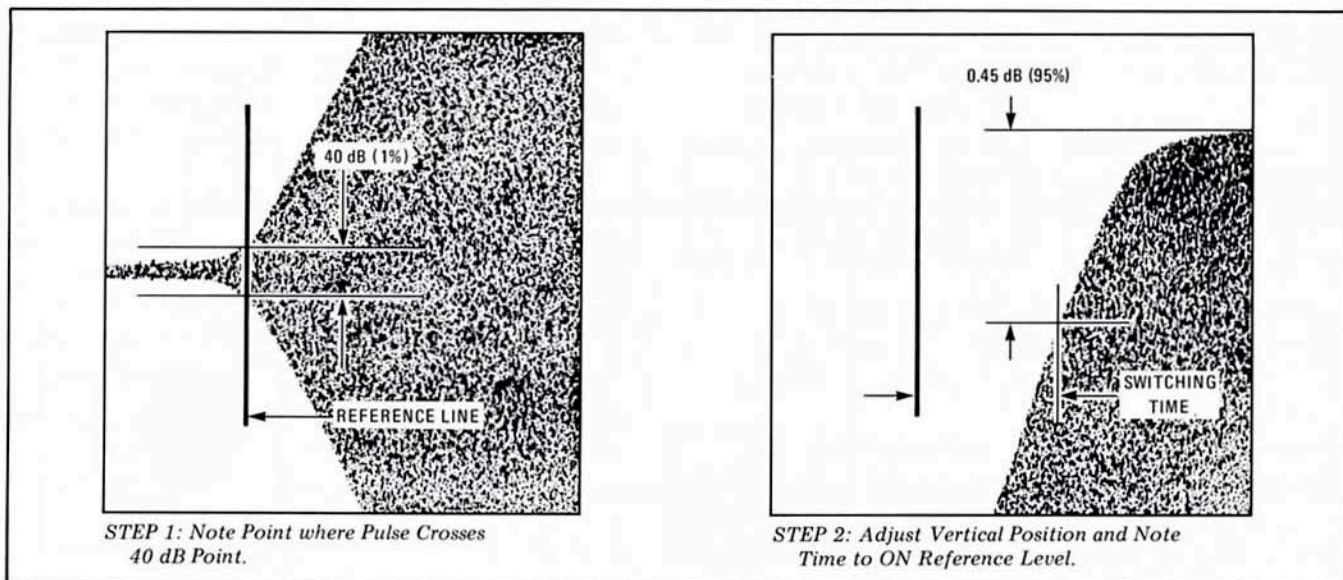

Figure 47. Technique for 40 dB Switching Measurement.

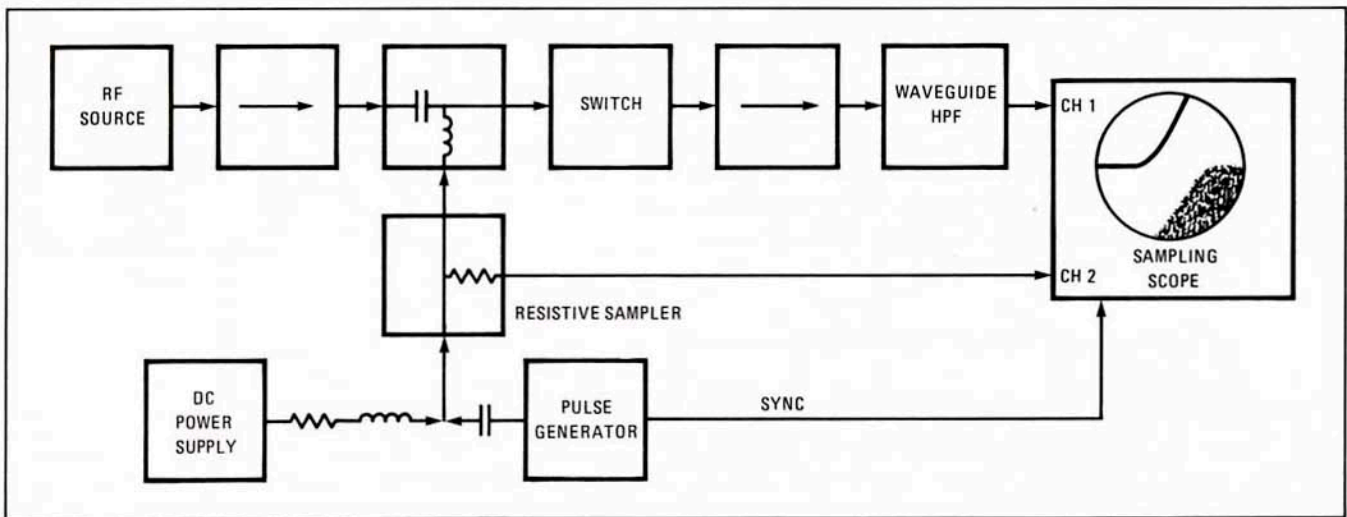

Figure 48. Wide Range OFF to ON Setup.

when the switching pulse arrives at the bias port and the time when the RF pulse reaches some level of ON. Assuming no significant delay in the bias network, this is a full OFF to ON measurement, regardless of the dynamic range.

ON to OFF measurement is more difficult. A limiter is utilized to expand the dynamic range of the sampling scope and an RF source capable of supplying 1 watt is required. Referring to Figure 49, the dc return for the limiter is provided with a manual switch, so that the limiter can be switched in and out of the system. The dynamic range of the system can be improved by biasing the limiter to a lower threshold, as described in Section VI-D).

The procedure is as follows:

1. With the limiter switched into the circuit and

the attenuator set to zero, the RF level is adjusted so that the sampling scope is not quite saturated.

2. The attenuator is set to the desired OFF level (for example, 70 dB) and the vertical height of the RF level is noted on the scope face.
3. Set the attenuator to about 20 dB, switch the limiter out of the circuit, turn on the power supply and pulse generator, and make a horizontal reference at the point where the pulse starts to turn off (see Figure 50).
4. Switch the limiter in, set the attenuator to zero, adjust the vertical position, and read the switching time.

The major problem with this measurement is that the effects of the system mismatches are almost overwhelming. The large number of compo-

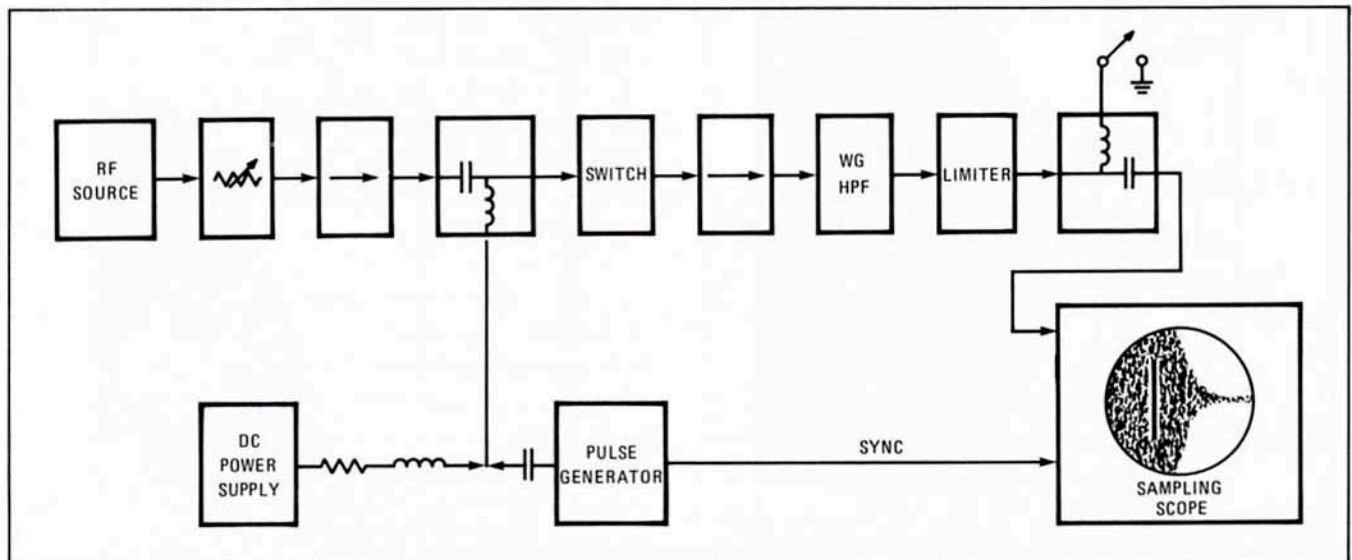

Figure 49. Wide Range ON to OFF Setup.

nents in the line makes it extremely difficult to reduce mismatches and keep the line short.

This technique is restricted to switching times of 20 ns or greater; the recovery time of the limiter is several nanoseconds, which restricts the measurement to switches somewhat slower than that.

**E. General Troubleshooting Hints**

When a switch or limiter gives an indication of improper operation, it is often difficult to determine whether it is the component or the system that is at fault. The following hints should make it easier to resolve the question.

1. The most common failure mechanism in modules is the situation with one or more diodes open or one or more diodes shorted. An ohmmeter can be utilized to determine shorts; it will also indicate if all of the diodes are open, but will not indicate if only some of them are open. The typical reverse resistance is several thousand ohms; the forward reading depends upon the impedance of the ohmmeter — it will range from a few ohms to a few tens of ohms.
2. The most common failure mechanism in complete switches is opens or shorts in the modules, opens or shorts in the bias network, shorted blocking capacitors, and damaged connectors. An ohmmeter will detect the first three (except

when only some of the diodes are open) and careful inspection will reveal connector damage.

3. If isolation is low, there are three likely causes:
  - (a) Some of the diodes are open circuited.
  - (b) A blocking capacitor is shorted and some of the bias current is being shunted into some other part of the system.
  - (c) RF leakage (see Section IX-C).
4. If insertion loss is high, suspect limiting. A quick check can be made by dropping the RF power level to see if the insertion loss changes.
5. If switching speed is abnormal but the switch functions well in the static mode, the problem is in the system, since there is no failure mode that will affect only switching speed.

**F. Module Fixtures**

In order to test modules outside of the system, fixtures are required. Figure 51 shows details of fixtures used by Hewlett-Packard to test modules; these are essentially reflectionless 50 ohm transmission lines through 18 GHz.

The transmission line sections should be secured to sturdy assemblies that afford a smooth sliding action and maintain perfect alignment. Several commercially available machinists' production fixtures are suitable for this application.

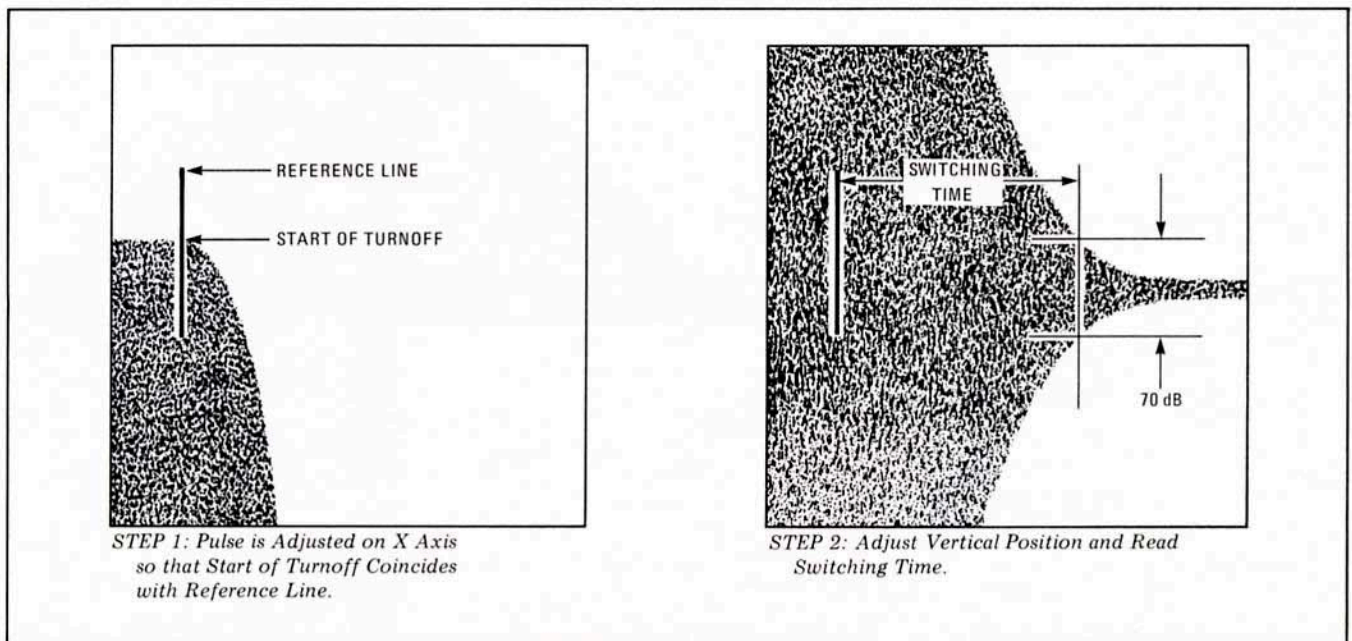
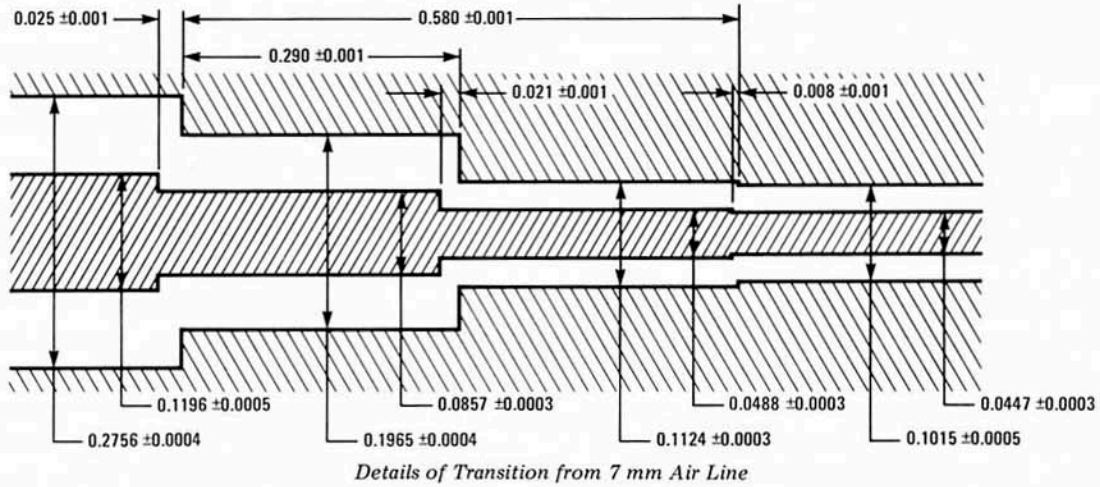
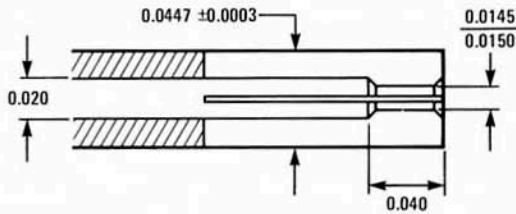

Figure 50. Wide Range ON to OFF Measurement Display.



Details of Transition from 7 mm Air Line

NOTE: CENTER CONDUCTOR MUST BE MADE IN TWO PIECES AND ASSEMBLED. COLLET END MATERIAL BERYLLIUM COPPER. CLOSE COLLET ON 0.011 DIA STAINLESS STEEL WIRE AND HEAT TREAT AT 600°F FOR TWO HOURS.



Center Conductor Details



0.004 SAW SLOT  
2 PLACES 90° APART  
0.125 DEEP. CSK  
60° x 0.022 ± 0.002 D/A.

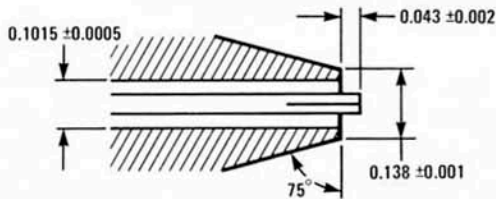

Transition for Coaxial (33600) Modules

Figure 51. Module Fixtures.

Hewlett Packard assumes no responsibility for the use of any circuits described herein and makes no representations or warranties, express or implied, that such circuits are free from patent infringement.

For more information, call your local HP Sales Office or East (201) 265-5000 • Midwest (312) 677-0400 • South (404) 436-6181 • West (213) 877-1282. Or, write: Hewlett-Packard, 1501 Page Mill Road, Palo Alto, California 94304. In Europe, Post Office Box 85, CH-1217, Meyrin 2, Geneva, Switzerland. In Japan, YHP, 1-59-1, Yoyogi, Shibuya-Ku, Tokyo, 151.