

# Ku-band Step Recovery Multipliers

## INTRODUCTION

This Application Note shows the design of a practical X8 single-stage Step Recovery Diode multiplier with typical maximum output power of 75 mW at 16 GHz. The design is based on HP 5082-0335 Step Recovery Diodes and is shown in detail with the intention of simplifying the reader's problems of reproducing the multipliers. Discussion of the design and references are given to aid the reader in the design of other multipliers with different performance requirements.

Detailed information on these Ku-Band diodes is available in the Data Sheet and in the Microwave and RF Designer's catalog. Additional background material on step recovery diodes and multipliers is found in A/N 918, 983, 984, and 989.

## I. HIGH FREQUENCY SRD MULTIPLIERS

The shunt mode of operation of the step recovery diode<sup>(1)</sup> provides a useful, straightforward design for frequency multipliers up to a frequency where the package inductance,  $L_p$ , becomes comparable to the drive inductance ( $L \cong \frac{X_o}{\omega_o}$ ;  $X_o = \frac{1}{\omega_o C_{VR}}$ ). For a shunt mode multiplier in a 50-ohm system, this happens at about 8-10 GHz. At higher

frequencies, alternative means of connecting the diode are needed which use the package inductance as one of the circuit parameters.

One way to do this is shown in Figure 2, the series mode. The waveguide circuit of Figure 1 can be reduced to this equivalent. The inductance,  $L$ , in Figure 2, can be the package inductance,  $L_p$ . The operation of the circuit is outlined below. The diode model is assumed to be a charge controlled switch.<sup>[1]</sup>

- 1) The diode is driven inductively and conducts most of the time, storing charge  $= \int i dt$  when the current is positive; exhausting charge when the current is negative.
- 2) After charge storage, the negative current, extracting charge from the SRD builds up a magnetic field in  $L$  where all the energy is stored just as  $Q \rightarrow 0$ . The diode switches from  $C_{FWD} (\approx \infty)$  to  $C_{VR}$ .
- 3) An impulse voltage is formed across the diode after it switches. This occurs once per input cycle. The width of the pulse,  $t_p \approx \pi \sqrt{LC_{VR}}$ , should be of the order of  $\frac{1}{2f_o}$ . The current in  $L$  and the diode reverses during the formation of this impulse, beginning the next interval of conduction and charge storage.

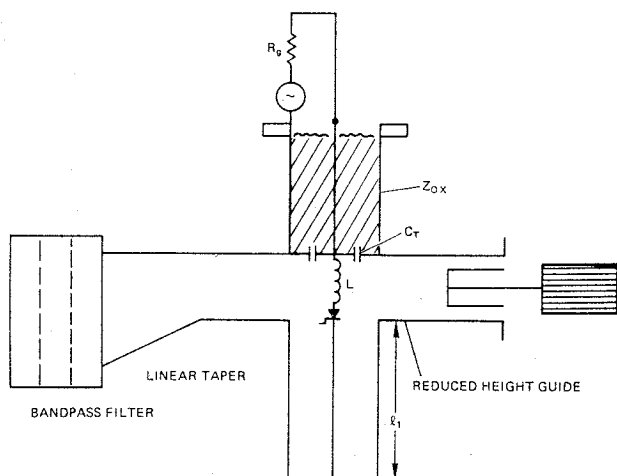

Figure 1. Schematic Diagram, Ku-Band, X8 Multiplier.

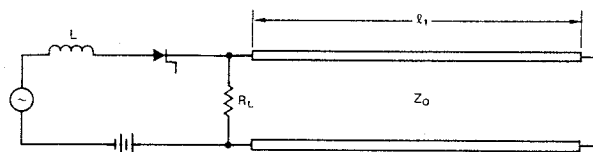

Figure 2. Series Mode Prototype.

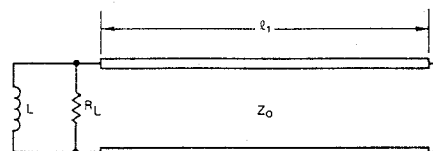

Figure 3. Output Network During Conduction Cycle of Diode.

- 4) This rapid current reversal in the diode shock excites the output transmission line which resonates at  $f_o$  after the diode closes, Figure 2.
- 5)  $R_L$  represents the output loading; it is adjusted by appropriate coupling to give  $Q_L \cong \frac{\pi}{2} n$  (the approximate desired  $Q_L$  for a single output resonator).

In Figure 4 a practical coaxial realization of this circuit is shown:

$\ell_1$  is as indicated in Figure 2.

$C_T$  tunes out the total inductance at the drive inductance input, since the diode conducts most of the time the input reactance is inductive  $\approx \omega_i L'$ , where  $L'$  is the total inductance including the diode  $L_p$  and the transmission line inductance.  $C_T$  also bypasses the input circuit at the output frequency.

$Z_{OX}$  is a quarter wave matching transformer, generally around  $15 \Omega$ .

$\ell_2$  allows the extra degree of freedom to adjust the output resonance cavity frequency to  $f_o$ . The overall output resonant cavity consists of  $\ell_1, \ell_2$ , and  $L_p$  of the diode.

The loading ( $R_L$ , Figure 2) required to bring  $Q_L$  of this output resonant network to  $Q_L = \frac{\pi}{2} n$  is not shown in

Figure 4. It can be loaded by using a coupling loop (magnetic field or a coupling probe (to the E field). It could also be loaded by coupling into a waveguide as in Figure 5. The waveguide loads the resonator exactly as any other coupling scheme would; the abrupt reversal of the current in the diode during the impulse interval shocks the coaxial cavity into resonance at  $f_o$ . This cavity is loaded by the  $H_{10}$  mode in the waveguide (Figure 5); the coupling to the mode is a function of<sup>[2, 3]</sup> the following:

- 1) The lengths  $\ell_1$  and  $\ell_2$ . These determine the coax field strength at the intersection.
- 2) The impedance of the coax; this is one factor in the loaded Q of the coax resonator.

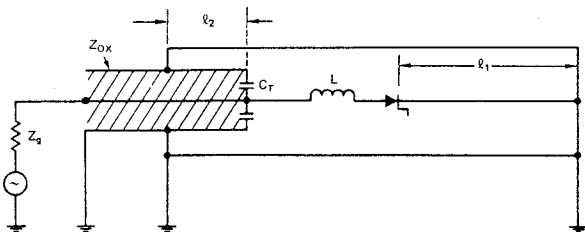

Figure 4. Coaxial Series Mode Circuit.

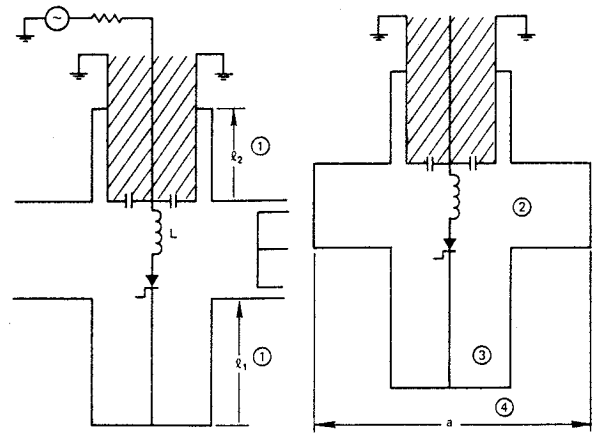

Figure 5. General Waveguide to Coaxial Coupling. The important factors influencing this coupling are (1)  $\ell_1$  and  $\ell_2$ , (2) the waveguide impedance, (3) the coaxial impedance and (4)  $X$  the position of the crossing on the broadwall of the guide ( $a$  dimension).

- 3) The waveguide impedance; this determines the absolute maximum guide impedance the coax centerwire could

see at  $\frac{a}{2} = X$ .

- 4)  $X$ , the relative crossing position across the broadwall of waveguide.

All of these factors affect the loading of the multiplier. In order to simplify the first design,  $\ell_2$  was chosen = 0.\* The

impedance of the coax ( $\ell_1$ ) was set at  $15 \Omega$  and  $X = \frac{a}{2}$ , the

coax crossed the guide at the center line. This sets the coupling coefficient between the coaxial resonator and the waveguide and so adjusts the loaded Q.

## II. Ku-Band Multiplier

A cross-sectional drawing of the multiplier of Figure 1 is shown in Figure 6. Line length  $\ell_1$  is adjustable by spacers in 0.005-in. steps to 0.370 in. This length was optimized for maximum power output ( $\ell_1 = 0.300$  in. for X8, 2 GHz to 16 GHz).  $C_T$ , the bypass capacitor, is an annular ring, 0.001 in. thick Mylar dielectric between the end of the coaxial center conductor and the top wall of the waveguide it shoulders against. The design is such that the Rexolite bead in the precision Type N connector exerts a slight positive pressure on the center conductor holding  $C_T$  rigidly in place.

\* For this design,  $\ell_2 = 0$  was found to be adequate.  $\ell_2$  was shown in the circuit for generality since this extra degree of freedom may be of value in multiplication not centered at  $f_o = 16$  GHz.

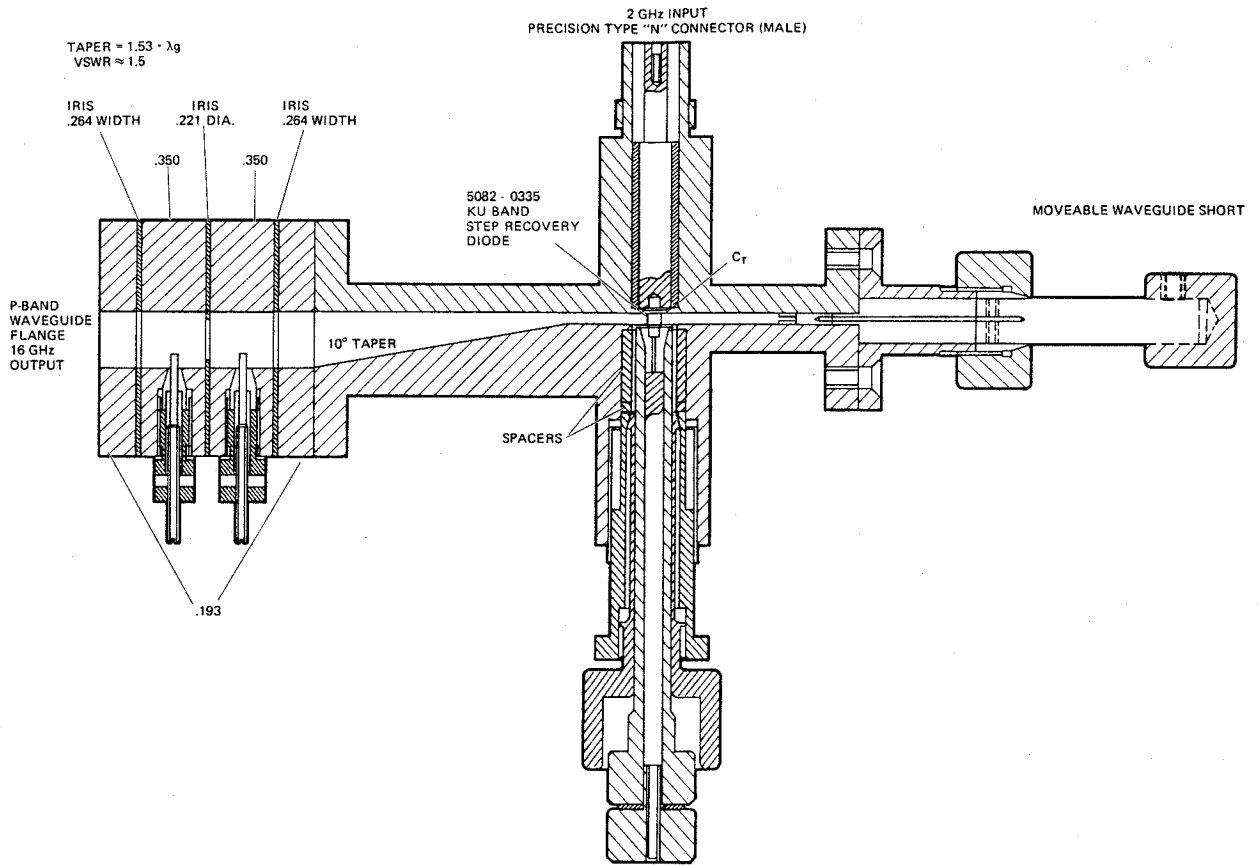

Figure 6. X8, Ku-Band Waveguide Multiplier.

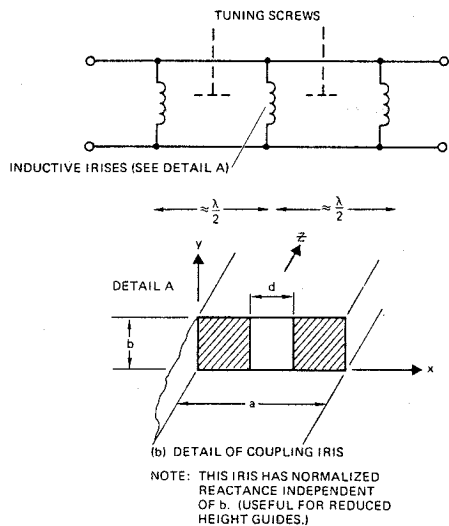

Figure 7. Waveguide Bandpass Filter.

The bandpass filter used is a conventionally designed<sup>[4]</sup> filter of  $\frac{\lambda}{2}$  resonators inductively coupled by thin irises,

Figure 7. The resonators were foreshortened slightly to accommodate tuning screws (which tend to lengthen the line). The two-element bandpass filter used was designed for 500 MHz bandwidth at 16 GHz. The tuning of the first resonator was readjusted when it was operated with the multiplier mount, which changed the bandwidth and response of the filter as will be seen below.

The experimental setup used to evaluate this multiplier and diode is shown in Figure 8. The padding on the output of the 2 GHz signal generator is very important for clean CW signal production in the multiplier; the same is true of the pad between the multiplier and the spectrum analyzer—which sometimes has leakage coming out the RF input port at levels high enough to cause parametric effects.

Figure 9 (Curve A) shows the power output of the multiplier vs. power input. Typical efficiencies of 15% at 60 milliwatts output have been measured. The maximum power output measured was 90 milliwatts. The importance of fast transition time in this kind of a circuit is emphasized in Figure 10 which shows the correlation of efficiency and corrected†

transition time at 100 pico-coulombs. Significant typical measured data on this multiplier are presented below:

Power incident (2 GHz)	= 650 milliwatts
Power reflected	= 150 milliwatts
Power output	= 60 milliwatts
Voltage bias	= 1.4 volts negative (self or external)
Bias resistance	= 350 Ω
Sideband level	= 20 dB down from main line
Bandwidth (3 dB)	= 30 MHz

† Transition times (60 ps, max.) quoted in the data sheet are total, measured, 20%-80% risetimes. To obtain the corrected transition time, vectorially subtract the RC time constant ( $R = 25 \Omega$ ) and the scope 20%-80% risetime (21 ps).

$$t_{t(\text{corrected})} = \sqrt{(t_{t(\text{measured})})^2 - (1.4 RC_{VR})^2 - (21)^2 \text{ ps}}$$

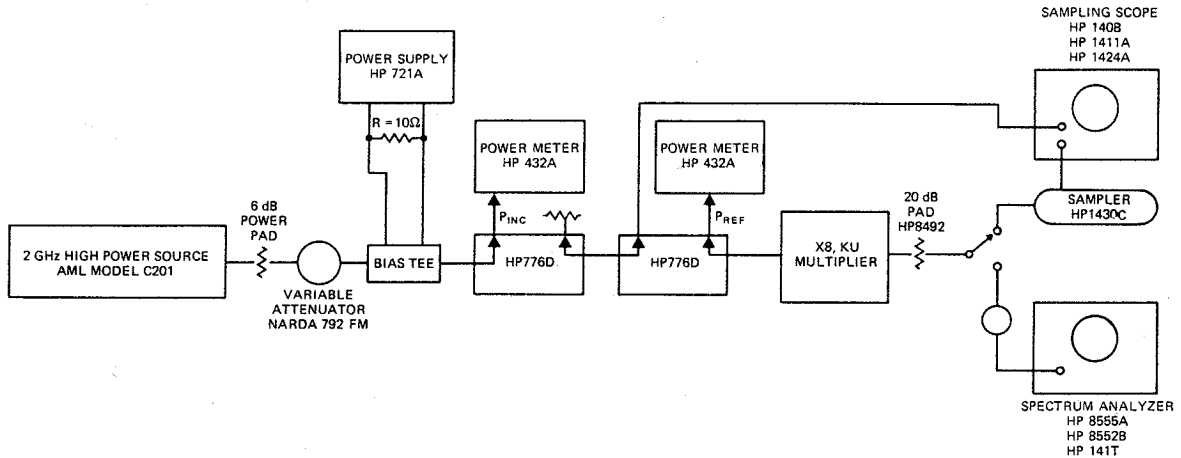

Figure 8. Test Setup—Ku-Band Multiplier.

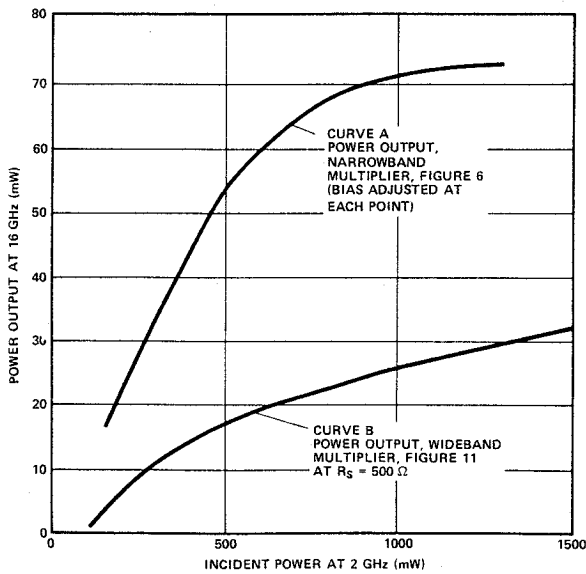

Figure 9. Power Output Characteristics of Narrow and Broadband, X8 Ku-Band Multiplier.

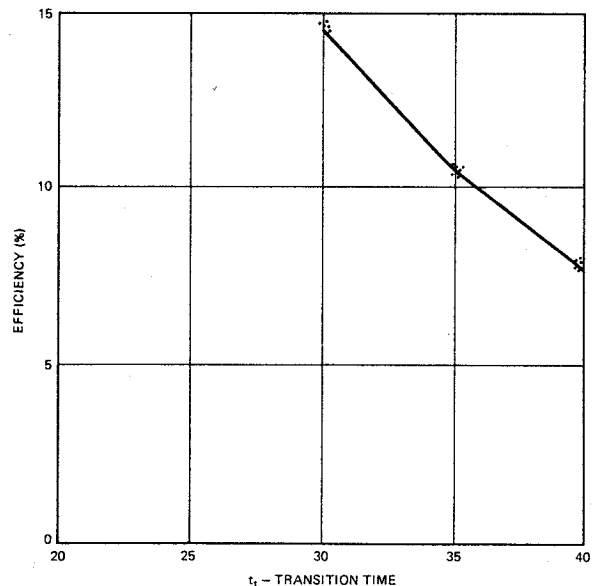

Figure 10. Correlation Between X8 Multiplier Efficiency and Corrected 20-80% Transition Time (Data on 25 Diodes).

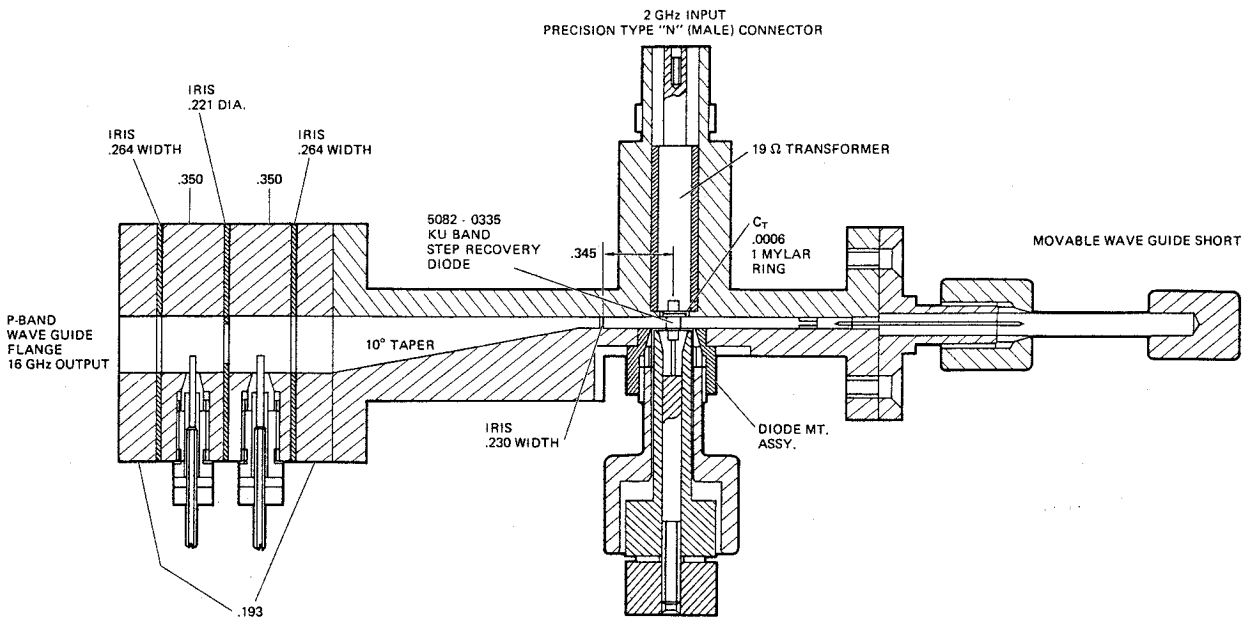

Figure 11. Broadband X8 Frequency Multiplier, Ku-Band. Stub  $I_1$  has been removed and an iris placed in the reduced height guide near the diode.

### III. Broadbanding of Multiplier

The multiplier of Section II is narrowband. By designing the diode output impedance into the output bandpass filter in the reduced height waveguide section, controlled multiplier frequency response may be achieved.

Figure 11 shows a modified broad bandwidth version of the X8 multiplier of Figure 1, where the following changes were made:

- 1) The coaxial stub  $\ell_1$  has been removed (the diode is sitting on the bottom wall); this forces readjustment of the waveguide short position.
- 2) The first coupling iris has been placed in the reduced height waveguide (instead of after the taper, as in Figure 6).

- 3) A conventional waveguide bandpass filter, as before, is placed after the taper. Very slight adjustment of the first tuning screw was needed when the tuned-up bandpass filter was added to the multiplier.

Figure 12 shows the bandpass and bias characteristic of this multiplier. All adjacent lines were greater than 40 dB down from the main, X8, 16 GHz line. No spurious oscillations or spectral breakup was measurable over the band. Smooth bias behavior, necessary in a well-behaved multiplier circuit, was found in this circuit. The second region where power output exists (between 2.9 volts and 3.6 volts bias, Figure 12b) is where the diode is snapping more than

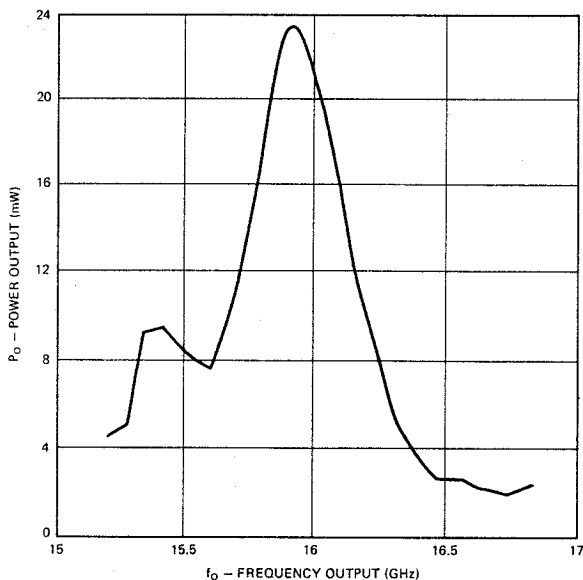

Figure 12a. Power Output as Function of  $f_o$  (Broadband Multiplier, Figure 11).

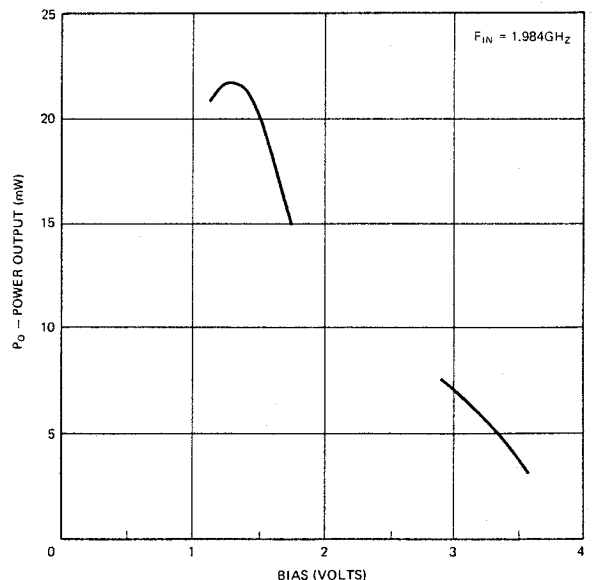

Figure 12b. Bias Characteristic at  $P_{in} = 650$  mW.

once per cycle. Smoother power characteristics and better overall stability result when the second transition region is avoided.\*\*

The power output as a function of input power is shown in Curve B of Figure 9. No readjustment of the bias resistance was required in this multiplier.

If flatter  $P_o$  versus  $f_o$  is a requirement, the remaining filter elements should be added in the reduced height section. Because the diode conducts (storing charge) for most of the input period, the dynamic behavior, as far as the output filter design is concerned, can be simulated by dc biasing the diode into forward conduction. The VSWR as a function of frequency looking into the output port at  $f_o$  gives a very good approximation of the required filter behavior. During this measurement, the input signal source may be completely removed. The level of  $f_o$  signal used in the measurement should be kept low ( $<-20$  dBm) so as to not affect the diode impedance. Further information on bandpass filter matching design procedure is given in Chapter 11.08, Reference 4.

#### IV. Conclusions

In this application note, a practical, SRD, waveguide multiplier has been shown. This kind of circuit is important at higher frequencies where the shunt mode is difficult to realize using discrete packaged devices. Series mode connection (whether coaxial or waveguide) to the diode allows the package inductance to be used in the circuit, somewhat relaxing the frequency constraints normally caused by package parasitics. Efficiencies of 15% narrowband and 5% broadband have been demonstrated with maximum output power of 75-90 milliwatts, X8 to 16 GHz. The techniques used here should be of general interest at  $f_o > 10$  GHz, provided diodes whose measured† transition time is less than  $\frac{1}{f_o}$  are used.

#### REFERENCES

- 1) Hall, R., and Hamilton, S.—"Shunt Mode Harmonic Generation Using the Step Recovery Diode," *Microwave Journal*, April 1967, p. 69.
- 2) Schelkenoff, S. A.—"Electromagnetic Waves," D. Van Nostrand Company, Inc., 1943.
- 3) Slater, J. C.—"Microwave Transmission," McGraw-Hill, 1942—Sections 37, 38, and 39.
- 4) Matthaei, Young, Jones—"Microwave Filters, Impedance Matching Networks and Coupling Structures," McGraw-Hill, 1964.
- 5) Hewlett-Packard Application Note 918.

\*\* This is true, even though, in some cases, the second transition region gives more power output. For some applications, however, this mode of operation may be justified.

† See data sheet for detail of measurement technique and setup.

#### SUMMARY

The HP 5082-0335 Step Recovery Diodes are intended for use as frequency multipliers with output frequency in the range of 12-20 GHz. Use of a special, epitaxial silicon process gives sharp profile definition at extremely small I-layer widths, resulting in an extremely fast (25 picoseconds at 100 picocoulombs) step recovery from low to high impedance states. The 5082-0335 will produce a minimum of 30 milliwatts of output power in a X8, 16 GHz waveguide frequency multiplier. Bandwidths of 450 MHz have been achieved at somewhat lower output power and efficiency (25 mW at 5% efficiency).

The basic multiplier discussed here is shown in Figure 1. The diode sits across a reduced height waveguide (0.622 in. x 0.060 in.) on top of a 15-ohm coaxial stub whose length is optimized for maximum power output at 16 GHz. The diode is driven by a matching coaxial quarter wave transformer, whose characteristic impedance is approximately 15 ohms. The diode is bypassed at the top wall of the waveguide by a 0.001-in. Mylar annular ring capacitor (10 pF). The 16 GHz energy is coupled into a full height waveguide bandpass filter through a linear taper; the waveguide short circuit tunes out the diode reactance at  $f_o$ . The waveguide bandpass filter is of conventional design in the narrowband case.

The multiplier is qualitatively explained by an equivalent series mode coaxial circuit (Section I). The waveguide output may be viewed as a special case of this circuit. The coaxial circuit is shown and its operation described. The waveguide output is then shown to be simply a special case of output loading. The first Ku-Band, X8 multiplier discussed is exactly as in Figure 1; cross-sectional drawings and data are given (Section II). Finally, results of some experiments in broadbanding the multiplier are given, including data and drawings of an  $\frac{100\%}{4n}$  bandwidth device at 16 GHz (Section III).

Hewlett-Packard assumes no responsibility for the accuracy of the described herein and makes no representations or warranties, express or implied, that such data is free from error.

For more information call your local HP sales office listed in the telephone directory white pages. Ask for the Components Department. Or write to Hewlett-Packard: U.S.A. — P.O. Box 10301, Palo Alto, CA 94303-0890. Europe — P.O. Box 999 1180 AZ Amstelveen, The Netherlands. Canada — 6877 Goreway Drive, Mississauga, L4V 1M8, Ontario. Japan — Yokogawa-Hewlett-Packard Ltd., 3-29-21, Takaido-Higashi, Suginami-ku, Tokyo 168. Elsewhere in the world, write to Hewlett-Packard Intercontinental, 3495 Deer Creek Road, Palo Alto, CA 94304.