

HP PIN PHOTODIODE

INTRODUCTION

HP silicon planar PIN photodiodes are ultrafast detectors of visible and near infrared radiation. The low dark current of the planar diodes enables detection of very low radiation levels. This note is intended to show how the characteristics of this diode apply in optical circuits and to explain the design principles for obtaining optimum performance.

AREAS OF APPLICABILITY

Isolation

The PIN photodiode can be used as the output of an isolating system in which the signal is transferred by means of radiation. This allows signal coupling among circuits whose reference potentials are widely separated by power supply voltages.

Unilateral Signal Transfer

The signal is transferred from the source of radiation to the detector, the reverse cannot happen and therefore the signal is in one direction only. Consequently, reactions of the load to the appearance of a signal cannot affect the conditions at the input. For example, if the output of an oscillator is coupled out via a modulated light beam, no tuning reactions of resonance or anti-resonance can have any pulling effect on the oscillator's frequency.

High-Speed Optical Signals

Having low capacitance the PIN photodiode responds well to the fast-rise time requirements imposed by tachometers, gyro pickoffs, card readers, flying-spot scanners, and laser data links.

Low-Level Optical Signals

Since the diode itself has such a very low noise current, the sensitivity/bandwidth tradeoff is a function only of the noise current (usually thermal) of the terminal circuit. The PIN photodiode is therefore suitable, with appropriate circuits for star tracking, photometry, and surveillance.

Doubtlessly, there are many other applications for which the PIN photodiode is suitable, but these should exemplify the general area of applicability.

Figure 1 gives the schematic diagram and equivalent circuit of HPA's PIN photodiode. Although an output from the photodiode is available even without bias, a reverse bias is recommended for enhancement of the response rise time and maintenance of high photon-to-electron conversion efficiency.

CIRCUIT MODEL

Schematic Diagram of Properly Biased PIN Photodiode

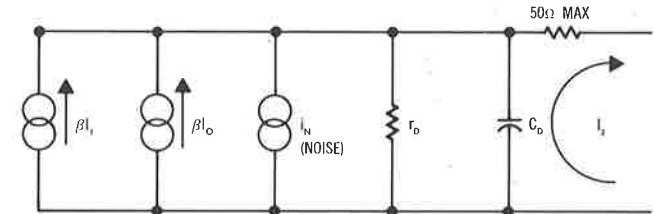
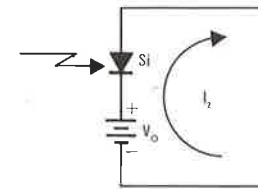

Equivalent Circuit of PIN Photodiode

where:

- β = current responsivity (μA per $\mu watt$)
- I_N = photodiode noise current
- r_o = leakage resistance
- C_o = diode capacitance

Figure 1

TYPICAL CIRCUITS

An amplifier is nearly always required at the output of the photodiode when dealing with low level signals. Since the speed of response is not affected by the picosecond time constant of the photon-to-electron conversion efficiency, there are only two basic considerations for the amplifier:

1. Reverse bias applied by the amplifier circuit to the photodiode should be as high as possible (up to 50 volts) in order to
 - a. reduce diode shunt capacitance,
 - b. enhance the value of β slightly
2. Input resistance of the amplifier must be
 - a. as high as possible for high gain or low noise requirements
 - b. as low as possible for high speed of response

In some cases, the use of negative feedback enables a combination of low noise and high speed, but the high dynamic resistance of the diode precludes any combination of high gain and high speed.

High Gain Circuit

A typical high gain circuit is shown in Figure 2. In this circuit the dynamic resistance seen by the photodiode is approximately the product of the load resistance and current transfer coefficient h_{re} of the transistor.

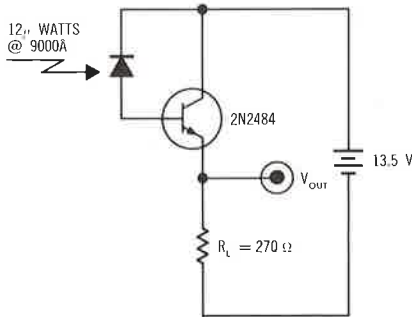

High Gain Circuit
Figure 2

Figure 3 shows the transient response of this circuit. The source of radiation is from a GaAs source which has been optically coupled to the PIN photodiode. The input pulse is related to the current driving the GaAs source.

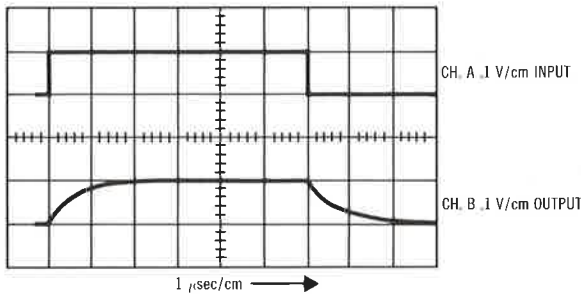

Figure 3

High Speed Circuit

As indicated by the equivalent circuit of the PIN photodiode, the speed of response is limited by the terminating preamplifier. To obtain high speed performance it is necessary to design the circuits carefully. Fast rise times can be obtained by simply ensuring that the photodiode preamplifier presents to the photodiode a low resistance and low capacitance load. Such a typical circuit is shown in Figure 4. The photodiode preamplifier has low input capacitance largely as a result of the transistor selected for use here. In general the transistor used should have low C_{ob} as well as low C_{ie} and its gain-bandwidth product (f_T) should be at least fifty times the highest desired operating frequency. Q1 is connected as an emitter follower, with its emitter connected to the base

of Q2. Having a ground collector, there is no feedback multiplication of the base-to-collector capacitance. The collector of Q2 is of opposite phase from the input signal, hence negative feedback is obtained simply by connecting the 15K resistor back to the base of Q1. The loop gain of the circuit given here is high enough that the signal voltage of the collector of Q2 is simply the product of the signal current (photodiode current) times the 15K feedback resistor. Loop gain may be high enough in such a connection that overshoot will occur. To obtain the phase lead necessary to widen the phase margin and control overshoot the R-C network is connected between the emitter of Q1 and the base of Q2. Were it not for this overshoot, the network could have been eliminated.

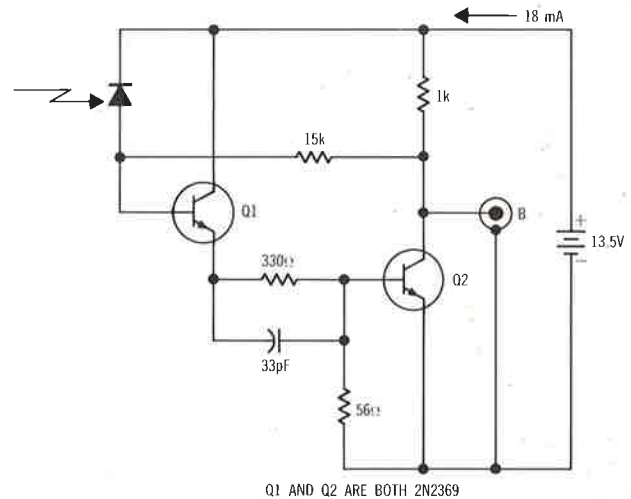

Figure 4

Notice that with the connection shown, the photodiode receives a fairly high reverse bias. This is necessary for highest gain-bandwidth in the photodiode. Adequate bias can be obtained for Q1 from either the photodiode (by biasing the light source) or from the feedback resistor. Bias for Q2 is obtained choosing a high enough value of resistance to connect between base and ground, so that all the emitter current of Q1 does not pass to ground.

Gain of the photodiode preamplifier is extremely stable, due to the large negative feedback, and, when it is driven with a fast rise (less than 10 nanoseconds) pulse, it gives a rise time of 15 to 20 nanoseconds.

GENERAL COMMENTS

The typical circuits given should serve to illustrate the techniques required to apply the design principles outlined and show how to obtain a suitable match between the photodiode properties and the system requirements. Care should be taken to observe the maximum limitations presented in the data sheet.