

USING THE 230A POWER AMPLIFIER

application
note
76

1 AUG. 67

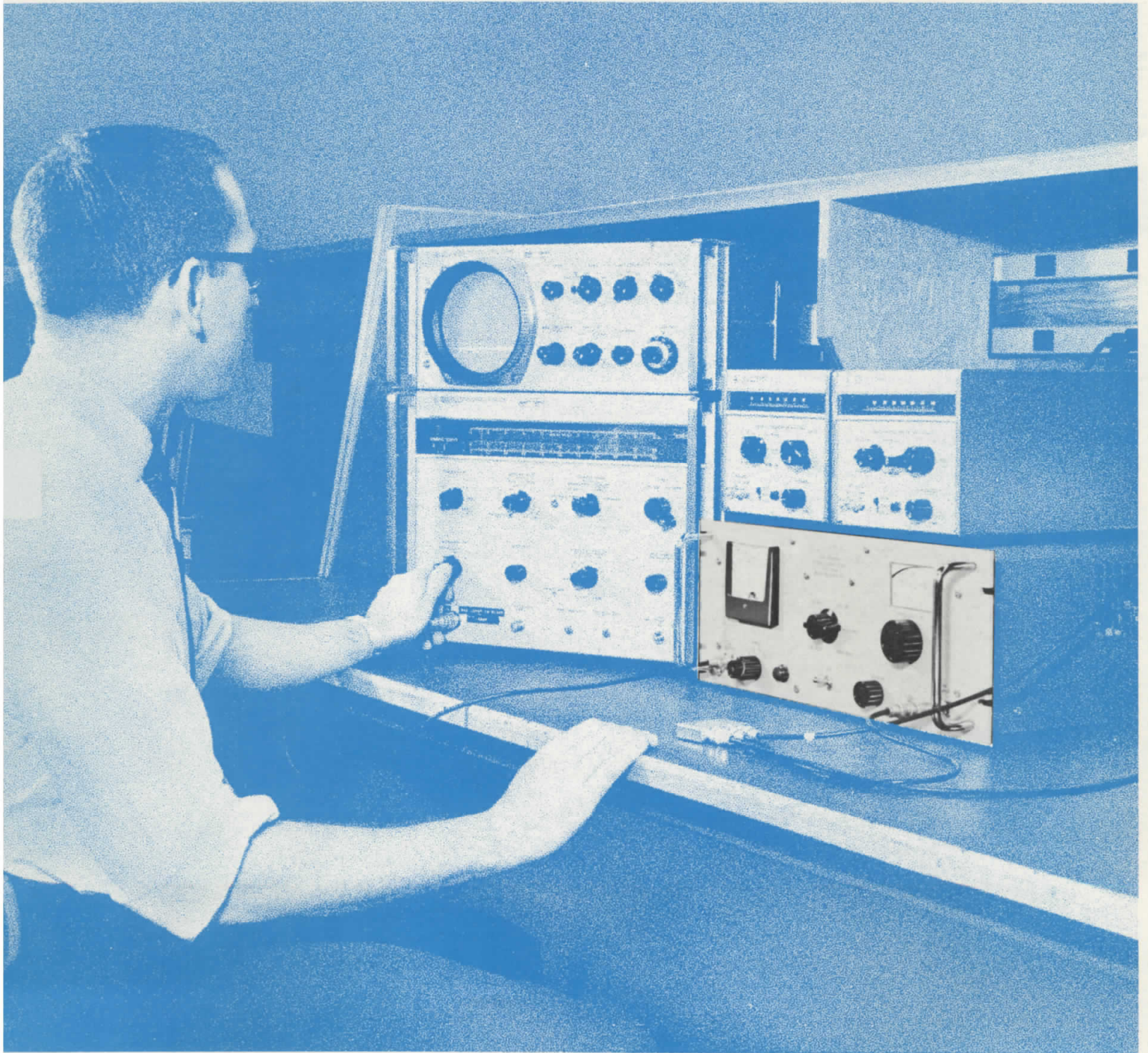

Green Pond Road, Rockaway, New Jersey 07866, U.S.A., Tel: (201) 627-6400



Europe: 54 Route des Acacias, Geneva, Switzerland, Cable: "HEWPACKSA" Tel: (022) 42.81.50

CONTENTS

HIGH-LEVEL APPLICATIONS

	Page
INTRODUCTION.	3
SIGNAL SOURCE REQUIREMENTS.	3
AMPLIFIER, RECEIVER, AND SYSTEM TESTING	3
Overload Tests.	3
AGC Characteristic	3
Skirt Selectivity	3
Adjacent Channel Desensitization Test	3
Cross Modulation and Intermodulation	4
Image and IF Rejection Tests	6
RF WATTMETER CALIBRATION	6
RF VOLTMETER CALIBRATION	6
COMPONENT TESTING.	6
HIGH-LEVEL DRIVER	7
ANTENNA TESTING	7
ATTENUATION MEASUREMENTS	7
FREQUENCY MULTIPLYING.	7
RADIO INTERFERENCE TESTING.	7
Screen Room Testing	7
Other RFI Applications	8
PULSE OPERATION	8
REMOTE SYSTEM CHECKING USING RADIATED SIGNALS.	8
SENSITIVITY MEASUREMENTS USING STANDARD FIELDS	9
Rules and Regulations	9

LOW-LEVEL APPLICATIONS

TUNED MICROVOLTMETER	10
Tuned Preamplifier for Spectrum Analysis	10
PREAMPLIFIER FOR FREQUENCY COUNTERS	10
"ON THE AIR" MEASUREMENTS	10
RF LEAKAGE DETECTION.	11
RECEIVER DESIGN	11
Low-Level Amplifier	11
REFERENCES.	11

HIGH-LEVEL APPLICATIONS

INTRODUCTION

The Model 230A is a tuned RF Amplifier that delivers 4.5 watts of output power over a frequency range from 10 to 500 MHz.

At first glance, the application of an RF Power Amplifier appears limited or obvious. While there are obvious uses, there are many applications which are not apparent. It is the purpose of this note to enumerate and discuss applications using both high and low levels. The specific requirements for the tests to be described are as many as varied as the systems involved. For this reason, this note will be limited to a general description and/or example of each test. Detailed information on radio receiver tests and radio frequency interference (RFI) testing is given in the references at the end of this note.

SIGNAL SOURCE REQUIREMENTS

Virtually any signal source, within the frequency range of the 230A, may be used to drive the amplifier. The obvious sources are signal generators such as the 608E and 3200B, the 202 series FM-AM generators, and the 211A and 232A Navigation Aid signal generators. Not so obvious, but nevertheless convenient signal sources, are the 260A Q Meter, the 250A RX Meter, crystal oscillators, frequency synthesizers, etc.

AMPLIFIER, RECEIVER, AND SYSTEM TESTING

Amplifier, receiver, or system testing may take many forms. A few of these tests are:

1. Overload tests.
2. AGC characteristics.
3. Skirt selectivity.
4. Adjacent channel desensitization.
5. Cross modulation and intermodulation.
6. Image and IF rejection.

A typical setup for tests 1, 2, 3, and 6 is shown in Figure 1.

Overload Tests

Overload tests are made to determine the input level at which the output of the unit under test

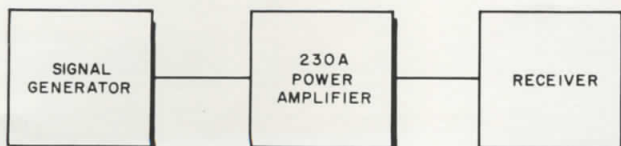

Figure 1. Setup for Receiver Testing

departs from a specified characteristic; i. e., linear, log-linear, etc., by a specified tolerance. Overload tests are usually made on circuits with active elements and are not restricted to the conventional superheterodyne receiver. Single frequency and broad-band amplifiers are also tested for overload.

The output of the unit under test may be the input signal amplified, or the demodulated output (AM, FM pulse, etc.), or a voltage or current proportional to input, (analog digital, dc, etc).

AGC Characteristic

AGC (automatic gain control) characteristics are measured or determined by measuring the relationship between RF input voltage and the dc voltage bias developed by the AGC detector. It is often desirable to determine the RF level which will override the AGC and cause blocking and/or distortion. This level is often much higher than 500,000 microvolts in well-designed systems. See Reference 1 for measurement details.

Skirt Selectivity

Skirt selectivity testing of a communications system requires that the performance of the frequency selective circuits be determined at a frequency considerably removed from the desired frequency, or on the "skirts" of the resonance curve, where attenuation is at a very high value. Typical values are 2 to 5 volts for attenuation figures of 80 to 120 db. In this test, one must be ever cautious of the possibility of overload occurring before the desired point on the skirt is reached. In AM systems, an increase in distortion indicates that overloading has taken place and limits the extent of the "skirt" measurement.²

Adjacent Channel Desensitization Test

Most communication centers transmit on many channels simultaneously. Usually, a given receiver will be in contact with signals of less than 100 microvolts in strength, while one or more transmitters in the same room are operating at a frequency only a few channels from the receiver frequency. The receiver must not, therefore, be affected by strong signals in adjacent channels. It is for this reason that desensitization characteristics are specified by communication system designers, and the desensitization tests are made.

Desensitization tests are made by connecting the equipment as shown in Figure 2. Signal generator #1 is set to give a convenient metered detector level (sometimes specified for a given system). This is the "desired signal" on channel. Using signal generator #2 in conjunction with the 230A Power Ampli-

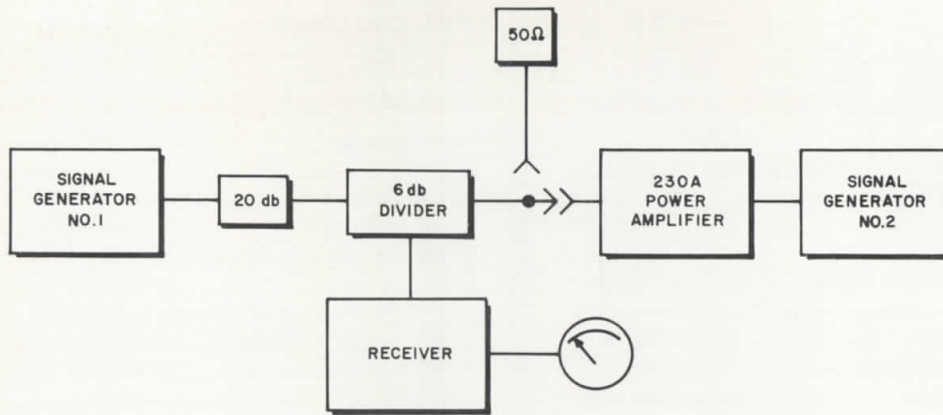

Figure 2. Connections for Desensitization Test

fier, the adjacent channel level is raised until the detector level is reduced by a specific amount (usually 3 db). The reading on the 230A voltmeter is twice the voltage required for "desensitization."

Cross Modulation and Intermodulation

Cross modulation and intermodulation tests are made on systems which are inherently very linear. Intermodulation tests are performed by supplying two or more signals to a system and measuring the resultant spurious products. For example, two 15-MHz signals, spaced 1 kHz apart, will produce a spectrum (Figure 3) which can be analyzed to determine the amount of intermodulation. Often these systems must be tested at high levels.

There are two approaches to this test, depending upon the amount of intermodulation expected. If the expected intermodulation is greater than 2 %, a single 230A amplifier may be used, connected as shown in Figure 4.

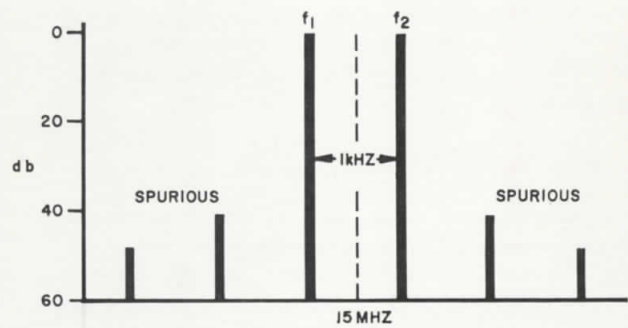

Figure 3. Spectrum for Analyzing Amount of Intermodulation

Typical intermodulation performance data, taken with the 230A connected as in Figure 4, is given in the table in Figure 5. The test unit was replaced by a 50-ohm termination and measurements were made at 15 MHz.

The data in Figure 5 is indicative of the intermodulation present in the 230A Power Amplifier,

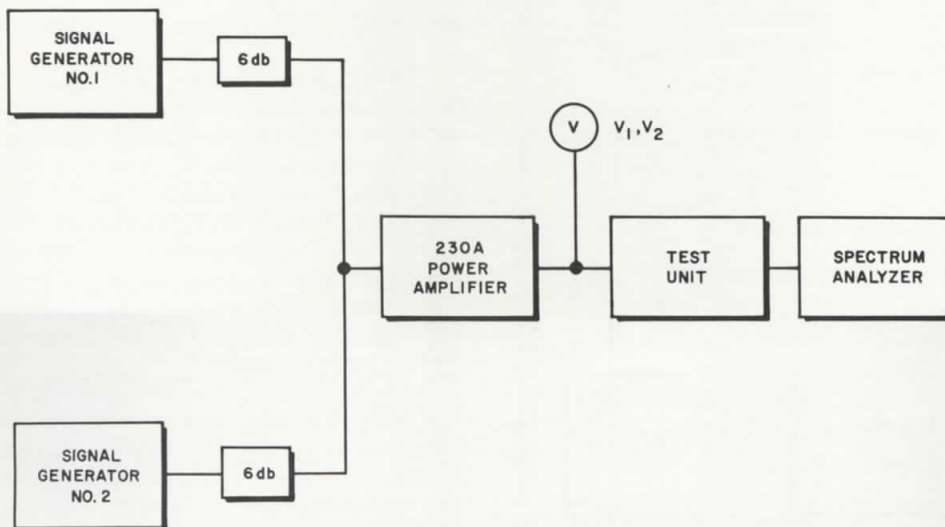

Figure 4. Connections for Checking More than 2% Intermodulation

V_1/V_2	V_T	db
1v	1.7v	-48
2v	3.5v	-46
3v	5.6v	-33
5v	8.7v	-24
7v	11.6v	-22

Figure 5. Typical Intermodulation Present 230A

and expresses its limits for given output levels. Column " V_1/V_2 " shows the value of the rms amplitude of one signal with the other signal turned off. Column " V_T " shows the meter indication when both signals are applied. The "db" column indicates the level of the highest spurious signal produced. It is the "db" column which is most significant. For instance, a figure of 46 db is typical of a 0.5% products; consequently, system intermodulation products of less than this figure will have little or no significance. Actually, any detected change in the spurious output, when using a passive linear termination, indicates a departure from linearity or phase shift. However, evaluation of absolute value is impractical.

There is another approach to the measurement of small amounts of intermodulation which extends this measurement another order of magnitude. The connections for this technique are shown in Figure 6. (The 230A meter switch is set to the "off" position for this application.) See Fig. 7 for spectrum displays.

This system virtually eliminates the intermodulation products present or generated in the driver stages of the 230A Power Amplifier. It also reduces the nonlinear effects of the dynamic plate resistance of the output stage by loading it with considerable linear, passive resistance. It is estimated that a 10-db coupling attenuator will be a good factor for V_1/V_2 values of 1 to 3 volts.

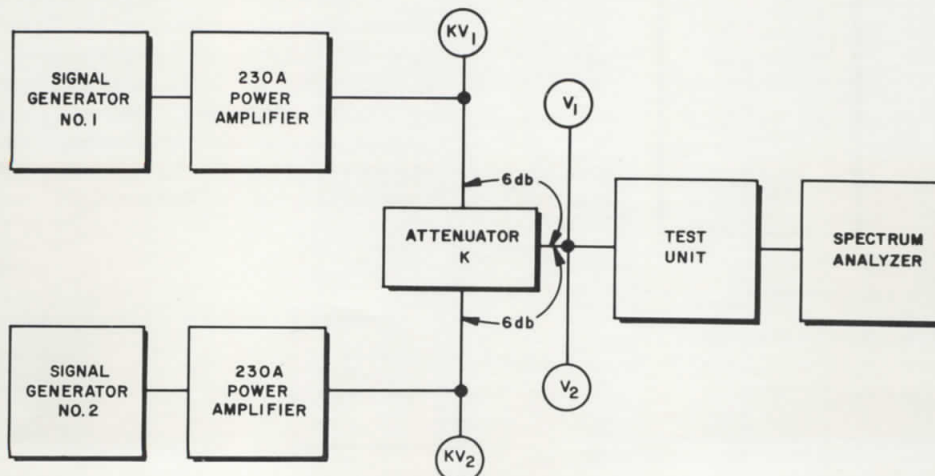

Figure 6. Connections for Checking Small Amounts of Intermodulation

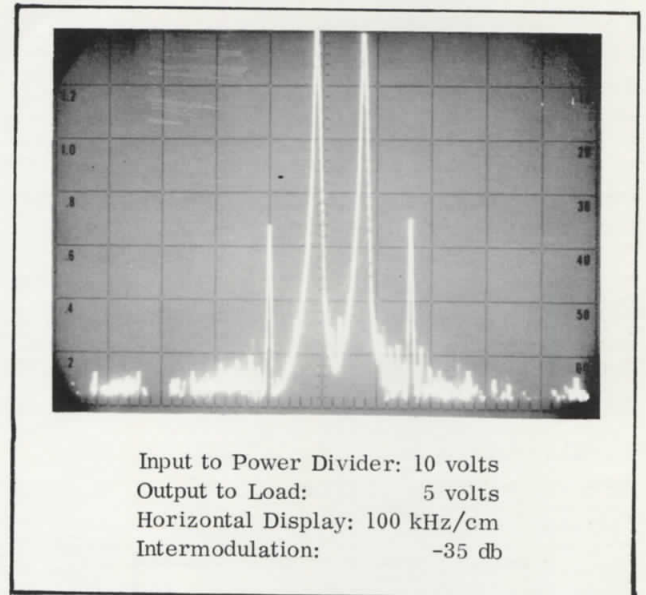
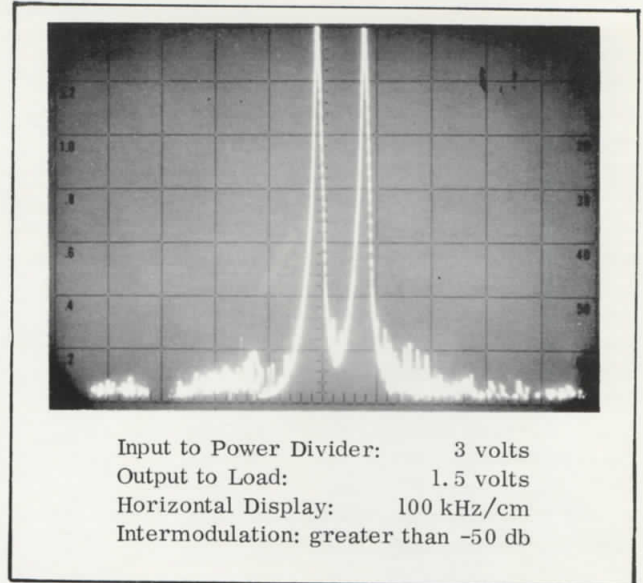

Figure 7. Spectrum Displays, Intermodulation

For cross modulation tests, two signals are required connected as shown in Figure 6. Signal generator #1 is set to a prescribed RF level (E_1 and percent modulation) depending upon the system being tested. The demodulated output is noted. Signal generator #2 and the 230A Power Amplifier are then connected and set on an adjacent channel in accordance with the specific test to be made. Signal generator #2 is modulated in the same manner as signal generator #1, which is now set for CW or unmodulated operation. The output (E_2) from the 230A is increased until the demodulated output equals that noted previously.

The cross modulation performance may then be calculated as follows: $C_m = 20 \log E_2/E_1$.

It should be observed that the demodulated output falls off when E_1 only is removed.

Image and IF Rejection Tests

Using the 230A Power Amplifier, IF rejection tests are made on receivers where this rejection is extremely high (in the order of 100 db or more). The image frequency (F_i) is that frequency which is twice the intermediate frequency (IF) away from the desired signal frequency (F_o), in the same direction as the local oscillator (F_{lo}). See Figure 8.

IF rejection is made at the intermediate frequency by driving into the receiver front end. This attenuation level is usually much higher than image rejection, so that even less sophisticated receivers may require use of the 230A Power Amplifier.

In AM systems, an increase in distortion indicates that overloading has taken place.

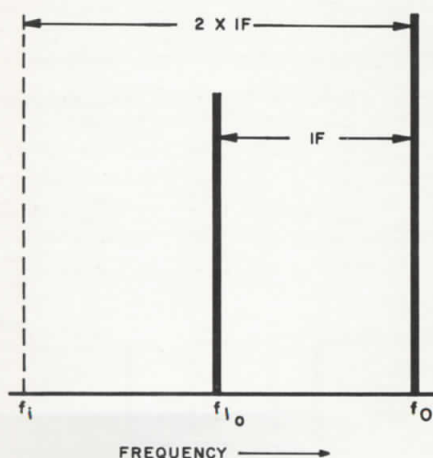

Figure 8. Image Frequency

RF WATTMETER CALIBRATION

RF wattmeter calibration is accomplished by using a standard signal generator in conjunction with the 230A Power Amplifier as a power source.

Power is then connected to the standard wattmeter, and then to the wattmeter to be calibrated. Up to 9 watts of power is available for short periods for this application. Higher than specified input levels are necessary, however, and the instrument must be properly terminated.

RF VOLTMETER CALIBRATION

The procedure for RF voltmeter calibration is somewhat different than for wattmeter calibration, since the voltmeter is usually a relatively high impedance device. The National Bureau of Standards has developed an A-T (Attenuator-Thermocouple) type standard RF voltmeter which may be used for this application. This instrument is a standard for RF voltages from 1 to 300 volts at 10 to 1000 MHz. The output voltage of the 230A is a function of loading and can be increased many fold over the 50-ohm value. Experiments to date, using line stretchers, stub tuners, and resonant transformers, indicate that voltages from 60 to 100 volts may be developed for voltmeter calibration and applications requiring large signal levels. Once again, however, the amplifier must be properly terminated.

COMPONENT TESTING

Component testing usually takes the form of a breakdown or parameter change which can be checked after subjecting the component to higher voltage or power stresses than are normally encountered in standard tests. Chokes, resistors, and capacitors are examples of such passive components. For example, in an actual test, a small 7.5 μ h choke subjected to 100 volts RF at 20 MHz, exhibited no change in Q or L after testing. It would be safe to conclude, therefore, that these chokes could be used up to this level. This application could also be extended to active components.

Diode rectification efficiency can be determined with the setup shown in Figure 9. The gain of power transistor circuits can be determined in a similar fashion, since the voltages are measurable with existing RF voltmeters. Circuits requiring high voltages; such as discriminators, limiters, power amplifiers, etc., may be supplied by the 230A. This is sometimes called "down-stage" testing.

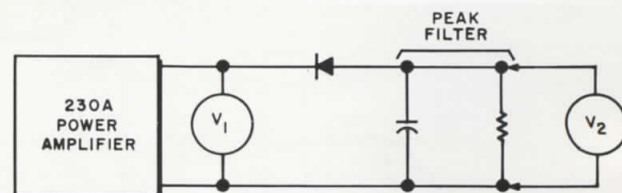

Figure 9. Connections for Checking Diode Rectification Efficiency

HIGH LEVEL DRIVER

As a high level driver, the 230A can be used to power bridges and slotted lines to improve the resolution and accuracy of these measurements. Computers that require high-level signal sources for synchronizing purposes, at moderately high frequencies, may also be driven by the 230A Power Amplifier.

ANTENNA TESTING

The 230A is capable of supplying moderate power for antenna measurements, while, at the same time, providing relatively small leakage from the Power Amplifier itself. This feature permits two antennas to be closer together, thereby shortening the range required.

ATTENUATION MEASUREMENTS

Using the 230A Power Amplifier and an RF millivolt meter, attenuation measurements can be made in the order of 80 db. The 230A provides an additional 28 to 40 db of gain or signal level (assuming the circuit being measured will permit the high voltage) to add to the existing measuring system in the field of attenuation measurements. Filters, long transmission lines, etc., can be tested in this manner.

Certain of these applications are susceptible to the absolute values of the source or load impedance. Where these impedances are critical, matching pads, attenuators, stub tuners or tunable networks may be employed to accomplish the necessary proper match for the application⁶.

FREQUENCY MULTIPLYING

A number of approaches to this application are possible. First, it is possible to amplify the harmonics present in the input signal. The output under these conditions is in the order of 0.2 to 0.5 volts, with 0.2 volts of fundamental input. Another approach is to use a semiconductor harmonic generator to augment the harmonics present in the input signal. This technique yields several volts output, depending upon the input levels available. See Figure 10 for spectrum display. If sufficient input is available, the 230A input stage may be overdriven and the attendant distortion will produce higher harmonic levels. Approximately 1 to 2 volts may be expected for inputs of the order of 1 volt. A crystal frequency synthesizer output may be multiplied as many as ten times, extending the usefulness of these units to the UHF range.

RADIO INTERFERENCE TESTING

Other applications of the 230A Power Amplifier are found in the Radio Frequency Interference (RFI) field of measurements.

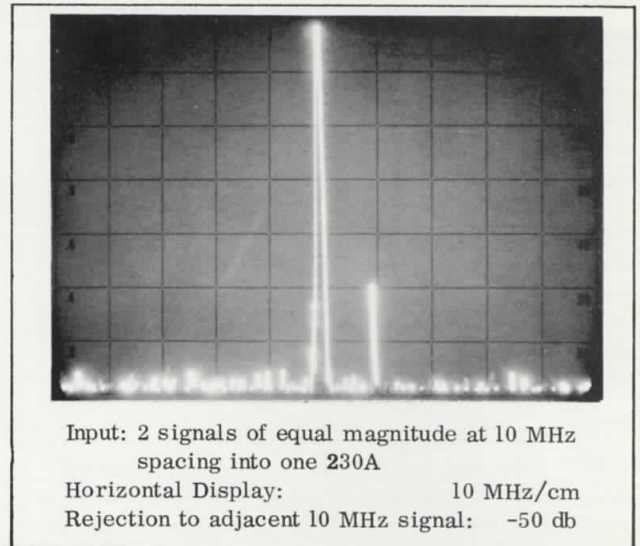

Figure 10. Spectrum Display with an -hp-8406A driving a 230A

Screen Room Testing

Screen rooms are used to reduce RFI in cases where equipment being tested or operated, is capable of causing RFI, or is sensitive to RFI. The screen room, in either case, must provide a prescribed amount of attenuation; usually in the order of 100 db or more.

A method for testing screen rooms is described in Military Specification, MIL-E-4957-A (ASG). This method has become general practice. The specification includes a test at 400 MHz; a frequency that has proved to be rather critical, regardless of room size.

In general, the procedure for making this 400 MHz test is as follows (Figure 11). First, a clear channel at approximately 400 MHz should be selected by listening with the field intensity measuring or receiving equipment antenna outside the shield room. The antenna is placed a few inches from the outside of the screen room to be tested, several feet from the transmitting antenna. If the receiving equipment has a calibrated attenuator system, the signal generator and Power Amplifier may be operated at full

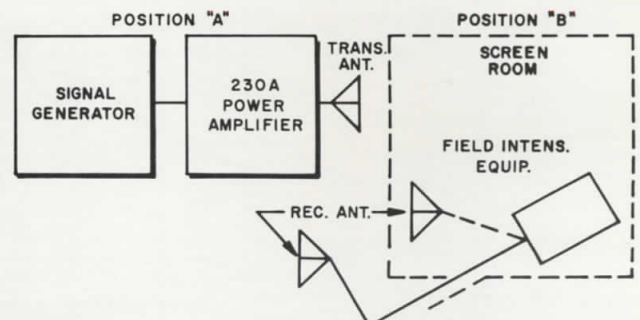

Figure 11. Setup for Screen Room Testing

output, and the attenuator set to give a convenient meter reading on the receiving equipment. Alternatively, the receiving equipment can be set to high sensitivity and the signal generator level adjusted to produce a convenient meter reading. The receiving antenna is then moved inside the screen room and placed within a few inches of the wall being tested. With full output from the 230A, the receiving antenna is used as a probe, along the seams, etc., and the point of maximum leakage is determined. The appropriate attenuator setting is read as the shielding attenuation figure. The procedure is repeated for the other walls of the screen room.

A paper⁵ was given at the 1961 IRE Convention in New York which described another approach for measuring shielding performance at critical frequencies. One of these frequencies is the frequency at which the screen room is resonant (f_o); usually between 50 and 200 MHz. The frequency (f_o) can be readily detected using a grid-dip meter technique. The procedure, described in the IRE paper, for making the attenuation measurement is basically the same as previously described except that the measurement is made at the center of the screen room.

Other RFI Applications

Other RFI applications include powering of probes, loops, etc., for the testing of filters, shielded cables³, and small compartments. It is also possible to conduct "Standard Susceptibility to Radiation Tests."⁴ The output of the 230A Power Amplifier is sufficient to set up standard field intensities of greater than 1 volt per meter throughout most of the frequency range.

Pulse Operation

It has been found that if enough drive is available, the 230A may produce as much as 16 watts peak with duty cycles of 0.25 or less at some frequencies. The

rise time of the pulse t_r will be limited by the bandwidth at the frequency of operation. Typical values may be calculated using the equation:

$$t_r = \frac{.707}{f_{\text{MHz}}} \quad \text{microseconds}$$

(f_{MHz} is the bandwidth at the 3 db points.)

and the bandwidth data in Figure 12.

REMOTE SYSTEM CHECKING USING RADIATED SIGNALS

How often does a piece of equipment operate normally on the bench, but not in its normal location? Or, on many occasions, an intermittent develops between the bench test and installation or reinstallation of the equipment. These conditions exist both for original installation of the equipment by the manufacturers of the system as well as for reinstallation at maintenance facilities. In other words, a final "on board" test is always desirable. This is especially true where public safety is involved. The need for these tests has been recognized by the Federal Communications Commission and the Federal Aviation Agency and frequencies have been allocated and test conditions specified for various purposes.

The 230A provides a solution to testing a remotely mounted system with laboratory type test equipment located in the lab.

In most instances, this will involve the testing of some type of mobile system, where a bench test has already verified proper performance and it is desirable to make a final operational test after final installation, or to determine if a bench test is necessary.

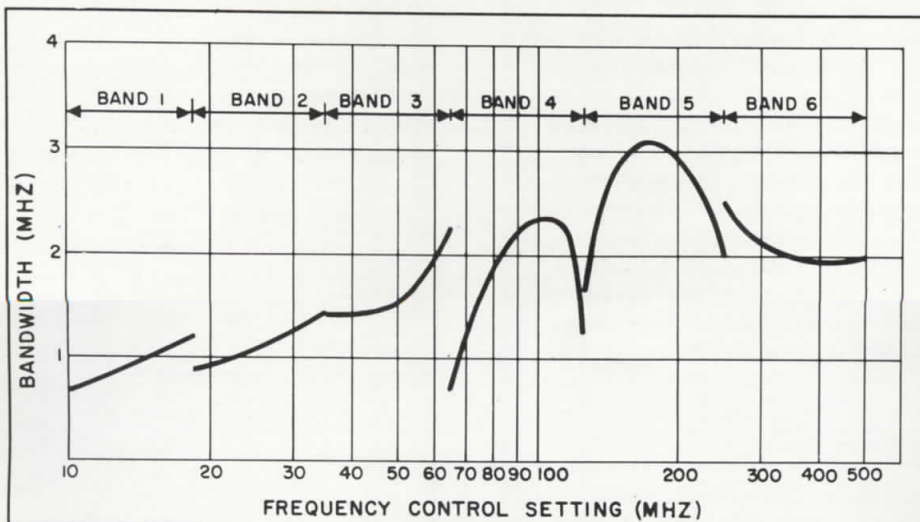

Figure 12. Typical Bandwidth vs. Frequency Curves for the 230A

Examples of these systems are:

1. Instrument Landing Systems and Visual Omni Range for Aircraft.
2. Marker Beacon and Voice Communications for Aircraft.
3. Marine Communications and Vehicular Communications.
4. Telemetry and Communications Systems.

The basic method is to use a short whip antenna connected to the 230A amplifier which in turn is driven by the specific test equipment required in the laboratory for the equivalent test. (See Figure 13.) For example, the 232A Glide Slope Signal Generator may be used to simulate glide path indications; or the 211A plus the necessary modulators will produce localizer "on" and "off" course indications or visual omni range simulation to produce a check on bearing indications. The 211A-230A combination can also be used to check out the communications channels on aircraft by using a 400 or 1000 Hz tone modulator.

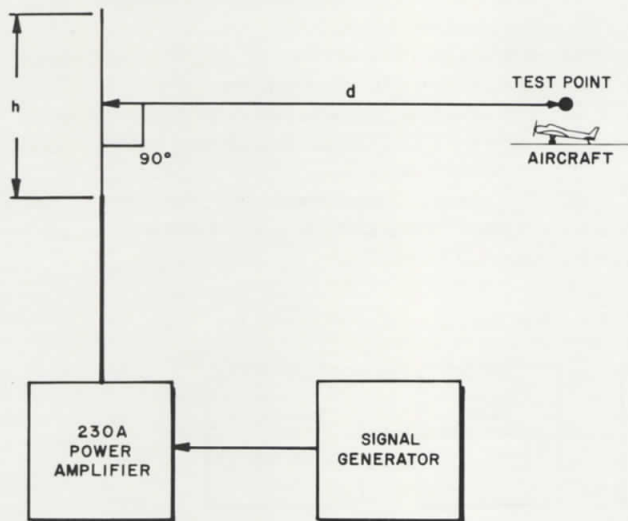

Figure 13. Using Radiated Signals

The antenna should be located just high enough to clear local vehicular obstacles, but low enough to reduce possibilities of interference with local services.

The size of the antenna and power delivered is a function of the actual location and specific application. Generally, for this frequency range, a whip antenna approximately one meter in length is adequate. Vertical polarization is generally desirable to minimize radiation in the vertical plane. The field intensity decreases as a function of the cosine of the angle.

Power input to the antenna should be limited to approximately 6 db above the minimum value required by a properly operating system. This is usually indicated by a flag or light incorporated in the system. The voltage, as indicated on the 230A, should also be kept below 3 volts. Excessive input to the 230A amplifier will result in envelope distortion and usually yield a false indication for the system test. The system will give a "flag up" or malfunction indication.

SENSITIVITY MEASUREMENTS USING STANDARD FIELDS

If the system sensitivity can be expressed in terms of field intensity, that is, microvolts per meter, the required field intensity can be set up as follows:

For vertical antenna whose height is .1 wavelength or less:

$$E = \frac{60 \times 10^6}{d} \times \frac{h}{\lambda} \times I_a$$

For vertical antenna whose height is .5 wavelength:

$$E = \frac{60 \times 10^6}{d} \times I_a$$

E = field intensity in microvolts per meter.

d = distance from transmitting antenna to receiving antenna in meters.

h = height or length of antenna in meters.

λ = wavelength of signal in meters.

I_a = RF current in antenna in amperes, as measured by an RF ammeter.

NOTE 1: $I_a = \frac{V}{Z}$

V = RMS voltage across antenna terminals.

(Z) = antenna impedance, if known or measurable.

NOTE 2: These equations apply to free space conditions, no buildings, etc.

The potential frequency range of this application is the entire spectrum of the 230A Power Amplifier, 10 to 500 MHz, subject to the rules and regulations of the FCC and FAA. (In some instances, there may be allocations for Test Stations, such as Flight Test Stations.⁸) Potential fields of application are manufacturers of aircraft equipment and major components, manufacturers of mobile equipment with radio frequency installations, and service facilities.

Rules and Regulations

These tests should not be made without consulting the local Federal Communications Office. The street addresses can be found in local directories under United States Government.

For the aviation services, the local office of the Federal Aviation Office should also be consulted.

LOW-LEVEL APPLICATIONS

The normal applications of the 230A Power Amplifier have been discussed under High-Level Applications.

Because of the choice of amplifier tubes, the noise figure of this new versatile amplifier is in the order of 6 to 8 db. Further, for most of the range, the noise figure is closer to 6 db. This feature opens another field of application — Low-Level Measurements. It is the purpose of this section to discuss the many ways this power amplifier can be utilized in low-level work.

TUNED MICROVOLTMETER

One of the most useful applications is the wedding of the 230A with the HP RF Millivoltmeter or 3406A broad-band Sampling Voltmeter. The voltmeter is connected as shown in Fig. 14, without a termination, but driving into the high-impedance probe. Stub tuning at the output may improve the gain and VSWR at some frequencies. Under these conditions, the 230A will provide approximately 40 db of gain. The result is that full-scale maximum sensitivity (which is normally 1 mv for the 3406A) is now approximately 10 μ v. This configuration can be used to detect leakage and for harmonic analysis, using substitution to determine the gain at the frequency of operation. In this application, it is possible to measure approximately 80 db of insertion loss with a 1-volt source voltage.⁵

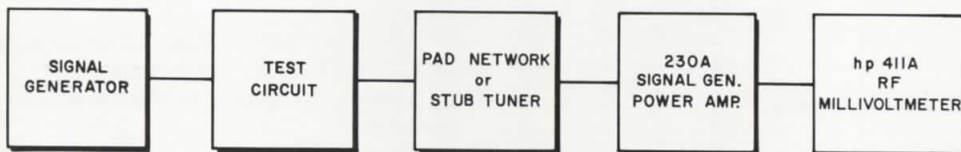

Figure 14. Tuned Microvoltmeter Setup with Stub Tuning

Tuned Preamplifier for Spectrum Analysis

In spectrum surveillance applications, where more sensitivity and selectivity are required, the 230A can be used in conjunction with the 851B/8551 Spectrum Analyzer. This system provides a minimum of 24 db of gain and as much as 30 db at some frequencies. Bandwidths are adequate for surveillance of most FM and AM signals within its frequency range. Typical bandwidth versus frequency characteristics are shown in Figure 12.

PREAMPLIFIER FOR FREQUENCY COUNTERS

When used in combination with the HP 5245L and 524 series counters with appropriate converters, the 230A Power Amplifier can make direct counter measurements possible with signal levels approximately 30 to 40 db below normal counter requirements.

"ON THE AIR" MEASUREMENTS

This application is especially useful when it is desirable to make transmitter measurements, without interrupting transmission, when direct connection to the transmission line is not desirable, or when the output of the transmitter is too low for normal measurements. In cases where direct connections are not made, an antenna may be substituted and remote measurements made from a distance up to several miles, depending upon the radiated power. (See Fig. 15.)

There are some precautions which should be taken in this application.

1. The effects of noise and modulation should be considered.
2. For AM signals, the negative modulation peak must not go below the triggering level.
3. For FM, the period must be sufficiently long for good averaging.
4. Even-order distortion, or carrier shift under modulation will be observed.
5. The absolute value of the peak noise voltage must be less than the triggering uncertainty, or hysteresis value.
6. The measurement must be made in the absence of interfering signals to the extent of the above noise limitation.

7. It is most desirable to check frequency at zero modulation.

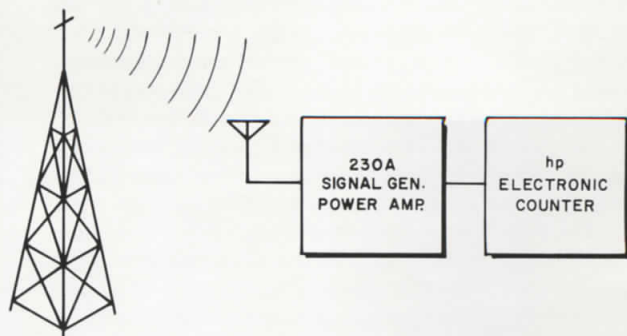

Figure 15. Setup for Remote Frequency Monitoring

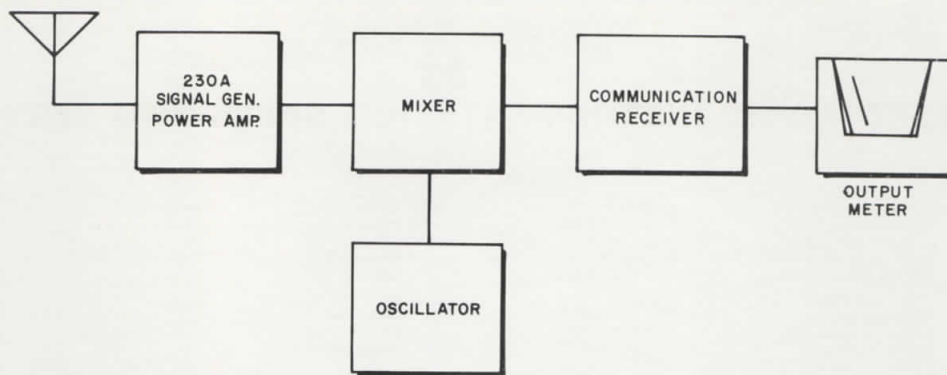

Figure 16. Setup for Leakage Testing

RF LEAKAGE DETECTION

In the design of RF equipment, it is often necessary to detect very small signals, much less than $1 \mu v$, usually picked up on a standard loop. When the frequencies involved get above 30 MHz, it is quite common to use a good communication receiver as an IF amplifier and precede it with a broad-band mixer. Normally, the insertion loss of the mixer will degrade the 10 db signal-to-noise ratio to approximately 10 to 20 μv . Adding the 230A Power Amplifier, as shown in Figure 16, will improve this figure to .2 to .5 μv for the same bandwidth of approximately 10 kHz.

RECEIVER DESIGN

In the early stages of receiver design, the 230A Power Amplifier has numerous applications:

1. In the development of the IF amplifier stages, the 230A can serve as a temporary front end or RF preselector.
2. It can be used to provide high levels for limiters and detectors at IF frequencies above 10 MHz.
3. It can be used to increase the output of a signal generator to determine proper mixing levels, thereby optimizing mixer gain and noise figure.

Low-Level Amplifier

As a low-level amplifier, the 230A can be used to amplify small signals, such as a crystal spectrum at a given frequency, for frequency drift measurements.

REFERENCES

1. Receiver Tests, IRE Standards 48-IRE-17.S1, 52-IRE-17.S1.
2. HF-VHF Communication System, ARINC Characteristic No. 520-A, April 1954, Sections 4.4 through 4.6.
3. Proceedings of the 6th Conference on RFI, Oct. 1960, Armour Research Foundation, Illinois Institute of Technology.
4. MIL-E-4957-A (ASG), Enclosure, Electromagnetic-shielding, Demountable, Prefabricated for Electronics Test Purposes.
5. "Shielding Enclosure Performance Utilizing New Techniques," R. B. Schultz, Armour Research Foundation, D. P. Kanellakos, Stanford University, IRE 1961.
6. -hp-Application Note #63A.
7. FCC Docket No. 15578. FCC Rules & Regulations - Vol II, V, VII, 1964.
8. Encyclopedia of Electronics Suskind (Rheinhold) Electronic Measurement, Terman & Pettit (McGraw-Hill).



ELECTRONIC INSTRUMENTATION SALES AND SERVICE

UNITED STATES

ALABAMA

P.O. Box 4207
2003 Byrd Spring Road S.W.
Huntsville 35802
Tel: (205) 881-4591
TWX: 810-726-2204

ARIZONA

3009 North Scottsdale Road
Scottsdale 85251
Tel: (602) 945-7601
TWX: 910-950-1282

232 South Tucson Boulevard
Tucson 85716
Tel: (602) 623-2564
TWX: 910-952-1162

CALIFORNIA

3939 Lankershim Boulevard
North Hollywood 91604
Tel: (213) 877-1282
TWX: 910-499-2170

1101 Embarcadero Road
Palo Alto 94303
Tel: (415) 327-6500
TWX: 910-373-1280

2591 Carlsbad Avenue
Sacramento 95821
Tel: (916) 482-1463
TWX: 910-367-2092

1055 Shafter Street
San Diego 92106
Tel: (714) 223-8103
TWX: 910-335-2000

COLORADO

7965 East Prentice
Englewood 80110
Tel: (303) 771-3455
TWX: 910-935-0705

CONNECTICUT

508 Tolland Street
East Hartford 06108
Tel: (203) 289-9394
TWX: 710-425-3416

111 East Avenue
Norwalk 06851
Tel: (203) 853-1251
TWX: 710-468-3750

DELAWARE

3941 Kennett Pike
Wilmington 19807
Tel: (302) 655-6161
TWX: 510-666-2214

FLORIDA

Suite 106
9999 N.E. 2nd Avenue
Miami Shores 33138
Tel: (305) 758-3626
TWX: 810-848-7262

P.O. Box 20007
Herndon Station 32814
621 Commonwealth Avenue
Orlando
Tel: (305) 841-3970
TWX: 810-850-0113

P.O. Box 8128
Madeira Beach 33708
410 150th Avenue
St. Petersburg
Tel: (813) 391-0211
TWX: 810-863-0366

GEORGIA

P.O. Box 28234
2340 Interstate Parkway
Atlanta 30328
Tel: (404) 436-6181
TWX: 810-766-4890

ILLINOIS

5500 Howard Street
Skokie 60076
Tel: (312) 677-0400
TWX: 910-223-3613

INDIANA

4002 Meadows Drive
Indianapolis 46205
Tel: (317) 546-4891
TWX: 810-341-3263

LOUISIANA

P.O. Box 856
1942 Williams Boulevard
Kenner 70062
Tel: (504) 721-6201
TWX: 810-955-5524

MARYLAND

6707 Whitestone Road
Baltimore 21207
Tel: (301) 944-5400
TWX: 710-862-0850
P.O. Box 727
Twinbrook Station 20851
12303 Twinbrook Parkway
Rockville
Tel: (301) 427-7560
TWX: 710-828-9684

MASSACHUSETTS

Middlesex Turnpike
Burlington 01803
Tel: (617) 272-9000
TWX: 710-332-0382

MICHIGAN

24315 Northwestern Highway
Southfield 48075
Tel: (313) 353-9100
TWX: 810-232-1532

MINNESOTA

2459 University Avenue
St. Paul 55114
Tel: (612) 645-9461
TWX: 910-563-3734

MISSOURI

9208 Wyoming Place
Kansas City 64114
Tel: (816) 333-2445
TWX: 910-771-2087

2812 South Brentwood Blvd.
St. Louis 63144
Tel: (314) 644-0220
TWX: 910-760-1670

NEW JERSEY

391 Grand Avenue
Englewood 07631
Tel: (201) 567-3933
TWX: 710-991-9707

NEW MEXICO

P.O. Box 8366
Station C 87108
6501 Lomas Boulevard N.E.
Albuquerque
Tel: (505) 255-5586
TWX: 910-989-1665

156 Wyatt Drive
Las Cruces 88001
Tel: (505) 526-2485
TWX: 910-983-0550

NEW YORK

1702 Central Avenue
Albany 12205
Tel: (518) 869-8462

1219 Campville Road
Endicott 13760
Tel: (607) 754-0050
TWX: 510-252-0890

236 East 75th Street
New York 10021
Tel: (212) 879-2023
TWX: 710-581-4376

82 Washington Street
Poughkeepsie 12601
Tel: (914) 454-7330
TWX: 510-248-0012

39 Saginaw Drive
Rochester 14623
Tel: (716) 473-9500
TWX: 510-253-5981

1025 Northern Boulevard
Roslyn, Long Island 11576
Tel: (516) 869-8400
TWX: 510-223-0811

5858 East Molloy Road
Syracuse 13211
Tel: (315) 454-2486
TWX: 710-541-0482

NORTH CAROLINA

P.O. Box 5187
1923 North Main Street
High Point 27262
Tel: (919) 882-6873
TWX: 510-926-1516

OHIO

5579 Pearl Road
Cleveland 44129
Tel: (216) 884-9209
TWX: 810-421-8500

2460 South Dixie Drive
Dayton 45439
Tel: (513) 298-0351
TWX: 810-459-1925

OREGON

Westhills Mall, Suite 158
4475 S.W. Scholls Ferry Road
Portland 97225
Tel: (503) 292-9171
TWX: 910-464-6103

PENNSYLVANIA

2500 Moss Side Boulevard
Monroeville 15146
Tel: (412) 271-0724
TWX: 710-797-3650

144 Elizabeth Street
West Conshohocken 19428
Tel: (215) 248-1600, 828-6200
TWX: 510-660-8715

TEXAS

P.O. Box 7166
3605 Inwood Road
Dallas 75209
Tel: (214) 357-1881
TWX: 910-861-4081

P.O. Box 22813
4242 Richmond Avenue
Houston 77027
Tel: (713) 667-2407
TWX: 910-881-2645

GOVERNMENT CONTRACT OFFICE
225 Billy Mitchell Road
San Antonio 78226
Tel: (512) 434-4171
TWX: 910-871-1170

UTAH

2890 South Main Street
Salt Lake City 84115
Tel: (801) 486-8166
TWX: 910-925-5681

VIRGINIA

P.O. Box 6514
2111 Spencer Road
Richmond 23230
Tel: (703) 282-5451
TWX: 710-956-0157

WASHINGTON

11656 N.E. Eighth Street
Bellevue 98004
Tel: (206) 454-3971
TWX: 910-443-2303

FOR AREAS NOT LISTED, CONTACT: Hewlett-Packard; 1501 Page Mill Road; Palo Alto, California 94304; Tel: (415) 326-7000; TWX: 910-373-1267; Telex: 34-8461

CANADA

ALBERTA

10010 - 105th Street
Edmonton
Tel: (403) 424-0718
TWX: 610-831-2431

BRITISH COLUMBIA

Hewlett-Packard (Canada) Ltd.
2184 West Broadway
Vancouver
Tel: (604) 738-7520
TWX: 610-922-5050

NOVA SCOTIA

7001 Mumford Road
Suite 356
Halifax
Tel: (902) 455-0511
TWX: 610-271-4482

ONTARIO

Hewlett-Packard (Canada) Ltd.
880 Lady Ellen Place
Ottawa 3
Tel: (613) 722-4223
TWX: 610-562-1952

Hewlett-Packard (Canada) Ltd.

1415 Lawrence Avenue West
Toronto
Tel: (416) 249-9196
TWX: 610-492-2382

QUEBEC

Hewlett-Packard (Canada) Ltd.
275 Hymus Boulevard
Pointe Claire
Tel: (514) 697-4232
TWX: 610-422-3022
Telex: 01-2819

FOR AREAS NOT LISTED, CONTACT: Hewlett-Packard Inter-Americas; 1501 Page Mill Road; Palo Alto, Calif. 94304; Tel: (415) 326-7000; TWX: 910-373-1267; Telex: 034-8461; Cable: HEWPACK Palo Alto

CENTRAL AND SOUTH AMERICA

ARGENTINA

Mauricio A. Suárez
Telecomunicaciones
Carlos Calvo 224
Buenos Aires
Tel: 30-6312, 34-9087
Cable: TELEPILOT Buenos Aires

CHILE

Héctor Calcagni
Casilla 13942
Santiago
Tel: 490.505, 393.119

COLOMBIA

Instrumentacion
Henrik A. Langebaek & Cia. Ltda.
Apartado 30323
Apartado Aereo 6287
Bogota, 1 D.E.
Tel: 45-78-06, 45-55-46
Cable: AARIS Bogota

BRAZIL

Ciental, Importacao e
Comercio Ltda.
Avenida 13 de Maio, 13-22° andar
Rio de Janeiro G.B.
Tel: 42-9483

COSTA RICA

Lic. Alfredo Gallegos Gurdian
Apartado 3243
San José
Tel: 21-86-13
Cable: GALGUR San José

ECUADOR

Laboratorios de Radio-Ingenieria
Calle Guayaquil 1246
Post Office Box 3199
Quito
Tel: 12496
Cable: HORVATH Quito

EL SALVADOR

Electronica
27 Avenida Norte 1133
Apartado Postal 1589
San Salvador
Tel: 25-74-50
Cable: ELECTRONICA
San Salvador

GUATEMALA

Olander Associates Latin America
Apartado 1226
7a. Calle, 0-22, Zona 1
Guatemala City
Tel: 22812
Cable: OLALA Guatemala City

MEXICO

Hewlett-Packard Mexicana,
S.A. de C.V.
Eugenia 408, Dept. 1
Mexico 12, D.F.
Tel: 43-03-79

NICARAGUA

Roberto Terán G.
Edificio Terán
Apartado Postal 689
Managua
Tel: 3451, 3452
Cable: RÓTERAN Managua

PANAMA

Electronica Balboa, S.A.
P.O. Box 4929
Ave. Manuel Espinosa No. 13-50
Bldg. Alina
Panama City
Tel: 30833
Cable: ELECTRON Panama City

PERU

Fernando Ezeta B.
Av. Petit Thouars 4719
Miraflores
Casilla 3061
Lima
Tel: 50346
Cable: FEPERU Lima

PUERTO RICO

San Juan Electronics, Inc.
P.O. Box 5167
Ponce de León 150, Stop 3
Puerta de Tierra Santa
San Juan 00906
Tel: (809) 725-3342
Cable: SATRONICS San Juan

URUGUAY

Pablo Ferrando
S.A. Comercial e Industrial
Avenida Italia 2877
Casilla de Correo 370
Montevideo
Tel: 40-3102
Cable: RADIUM Montevideo

VENEZUELA

Citec, C.A.
Edif. Arisan-Of. #4
Avda. Francisco de Miranda
Apartado del Este 10934 Chacaito
Caracas
Tel: 71.88.05
Cable: CITECAL Caracas

FOR AREAS NOT LISTED, CONTACT: Hewlett-Packard Inter-Americas; 1501 Page Mill Road; Palo Alto, Calif. 94304; Tel: (415) 326-7000; TWX: 910-373-1267; Telex: 034-8461; Cable: HEWPACK Palo Alto

ELECTRONIC INSTRUMENTATION SALES AND SERVICE

EUROPE

<p>AUSTRIA Unilabor H.m.b.H. Wissenschaftliche Instrumente Rummelhardtgasse 6/3 P.O. Box 33 Vienna IX/71 Tel: 426 181 Cable: LABORINSTRUMENT Vienna</p> <p>BELGIUM Hewlett-Packard Benelux S.A. 20-24 rue de l'Hôpital Brussels Tel: 11 22 20 Cable: PALOBEN Brussels</p> <p>DENMARK Tage Olsen A/S Ronnegade 1 Copenhagen o Tel: 29 48 00 Cable: TOCOPEN Copenhagen</p> <p>FINLAND INTO O/Y Meritulinkatu 11 P.O. Box 10153 Helsinki 10 Tel: 61 133 Cable: INTO Helsinki</p>	<p>FRANCE Hewlett-Packard France 2 rue Tête d'Or Lyon, 6 - Rhône Tel: 52 35 66</p> <p>Hewlett-Packard France 150 Boulevard Massena Paris 13e Tel: 707 97 19 Cable: HEWPACK Paris</p> <p>GERMANY Hewlett-Packard Vertriebs-GmbH Lietzenburger Strasse 30 1 Berlin W 30 Tel: 24 86 36</p> <p>Hewlett-Packard Vertriebs-GmbH Herrenberger Strasse 110 703 Böblingen, Württemberg Tel: 07031-6971 Cable: HEPAG Boblingen</p> <p>Hewlett-Packard Vertriebs-GmbH Achenbachstrasse 15 4 Düsseldorf 1 Tel: 68 52 58/59</p>	<p>Hewlett-Packard Vertriebs-GmbH Kurfürstenstrasse 95 6 Frankfurt 50 Tel: 52 00 36 Cable: HEWPACKSA Frankfurt</p> <p>Hewlett-Packard Vertriebs-GmbH Beim Strohhaue 26 2 Hamburg 1 Tel: 24 05 51/52 Cable: HEWPACKSA Hamburg</p> <p>Hewlett-Packard Vertriebs-GmbH Reginfriedstrasse 13 8 Munich 9 Tel: 69 51 21/22 Cable: HEWPACKSA Munich</p> <p>GREECE Kostos Karayannis 18, Ermou Street Athens 126 Tel: 230 301 Cable: RAKAR Athens</p> <p>IRELAND Hewlett-Packard Ltd. 224 Bath Road Slough, Bucks, England Tel: Slough 28406-9, 29486-9 Cable: HEWPIE Slough</p>	<p>ITALY Hewlett-Packard Italiana S.p.A. Viale Lunigiana 46 Milan Tel: 69 15 84 Cable: HEWPACIT Milan</p> <p>Hewlett-Packard Italiana S.p.A. Palazzo Italia Piazza Marconi 25 Rome - Eur Tel: 591 2544 Cable: HEWPACIT Rome</p> <p>NETHERLANDS Hewlett-Packard Benelux, N.V. de Boelelaan 1043 Amsterdam, Z.2 Tel: 42 77 77 Cable: PALOBEN Amsterdam</p> <p>NORWAY Morgenstjerne & Co. A/S Ingeniofirma 6 Wessels Gate Oslo Tel: 20 16 35 Cable: MOROF Oslo</p>	<p>PORTUGAL Telectra Rua Rodrigo da Fonseca 103 P.O. Box 2531 Lisbon 1 Tel: 68 60 72 Cable: TELECTRA Lisbon</p> <p>SPAIN Ataio Ingerieros Urgel, 259 Barcelona, 11 Tel: 230-69-88</p> <p>Ataio Ingenieros Enrique Larreta 12 Madrid, 16 Tel: 235 43 44 Cable: TELEATAIO Madrid</p> <p>SWEDEN HP Instrument AB Hagakergatan 7 Mälndal Tel: 031 - 27 68 00</p> <p>HP Instrument AB Centralvägen 28 Solna Tel: 08 - 83 08 30 Cable: MEASUREMENTS Stockholm</p>	<p>SWITZERLAND HEWPAK AG Zurcherstrasse 8952 Schlieren Zurich Tel: (051) 98 18 21 Cable: HEWPACKAG Zurich</p> <p>TURKEY Telekom Engineering Bureau P.O. Box 376 - Galata Istanbul Tel: 49 40 40 Cable: TELEMATION Istanbul</p> <p>UNITED KINGDOM Hewlett-Packard Ltd. 224 Bath Road Slough, Bucks Tel: Slough 28406-9, 29486-9 Cable: HEWPIE Slough</p> <p>YUGOSLAVIA Belram S.A. 83 avenue des Mimosas Brussels 15, Belgium Tel: 35 29 58 Cable: BELRAMEL Brussels</p>
---	--	---	--	--	---

FOR AREAS NOT LISTED, CONTACT: Hewlett-Packard S.A.; 54 Route des Acacias; Geneva, Switzerland; Tel: (022) 42 81 50; Telex: 2.24.86; Cable: HEWPACKSA Geneva

AFRICA, ASIA, AUSTRALIA

<p>AUSTRALIA Hewlett-Packard Australia Pty. Ltd. 22-26 Weir Street Glen Iris, S. E. 6 Victoria Tel: 20-1371 (4 lines) Cable: HEWPARD Melbourne</p> <p>Hewlett-Packard Australia Pty. Ltd. 4 Grose Street Glebe, New South Wales Tel: 211-2235, 211-2888 Cable: HEWPARD Sydney</p>	<p>HONG KONG Schmidt & Co. (Hong Kong) Ltd. P.O. Box 297 1511, Prince's Building 10, Chater Road Hong Kong Tel: 240168, 232735 Cable: SCHMIDTCO Hong Kong</p> <p>INDIA The Scientific Instrument Co., Ltd. 6, Tej Bahadur Sapru Road Allahabad 1 Tel: 2451 Cable: SICO Allahbad</p> <p>The Scientific Instrument Co., Ltd. 240, Dr. Dadabhai Naoroji Road Bombay 1 Tel: 26-2642 Cable: SICO Bombay</p> <p>The Scientific Instrument Co., Ltd. 11, Esplanade East Calcutta 1 Tel: 23-4129 Cable: SICO Calcutta</p> <p>The Scientific Instrument Co., Ltd. 30, Mount Road Madras 2 Tel: 86339 Cable: SICO Madras</p>	<p>The Scientific Instrument Co., Ltd. B-7, Ajmeri Gate Extn. New Delhi 1 Tel: 27-1053 Cable: SICO New Delhi</p> <p>IRAN Telecom, Ltd. P. O. Box 1812 Teheran Tel: 43850, 48111 Cable: BASCOM Teheran</p> <p>ISRAEL Electronics & Engineering Div. of Motorola Israel Ltd. 16, Kremenetski Street Tel-Aviv Tel: 35021/2/3 Cable: BASTEL Tel-Aviv</p> <p>JAPAN Yokogawa-Hewlett-Packard Ltd. Shinhankyu Building No. 8, Umeda Kita-ku, Osaka City Tel: 0726-23-1641</p> <p>Yokogawa-Hewlett-Packard Ltd. Ito Building No. 59, Kotori-cho Nakamura-ku, Nagoya City Tel: 551-0215</p>	<p>Yokogawa-Hewlett-Packard Ltd. B-7, Ajmeri Gate Extn. Ohashi Building No. 59, I-chome, Yoyogi Shibuya-ku, Tokyo Tel: 370-2281 Cable: YOKOHEWPACK Tokyo Telex: 232-2034</p> <p>KENYA R. J. Tilbury Ltd. P. O. Box 2754 Suite 517/518 Hotel Ambassador Nairobi Tel: 25670, 26803, 68206 Cable: ARJAYTEE Nairobi</p> <p>KOREA American Trading Co., Korea, Ltd. Seoul P. O. Box 1103 112-35 Sokong-Dong Jung-ku, Seoul Tel: 3.7049, 3.7613 Cable: AMTRACO Seoul</p> <p>LEBANON Constantin E. Macridis Clemenceau Street Clemenceau Center Beirut Tel: 220846 Cable: ELECTRONUCLEAR Beirut</p> <p>MALAYSIA MECOMB Malaysia Ltd. 2 Lorong 13/6A Section 13 Petaling Jaya, Selangor Cable: MECOMB Kuala Lumpur</p>	<p>NEW ZEALAND Sample Electronics (N.Z.) Ltd. 8 Matipo Street Onehunga S.E. 5 Auckland Tel: 667-356 Cable: ELPMS Auckland</p> <p>PAKISTAN (EAST) Mushko & Company, Ltd. 31, Jinnah Avenue Dacca Tel: 80058 Cable: COOPERATOR Dacca</p> <p>PAKISTAN (WEST) Mushko & Company, Ltd. Oosman Chambers Victoria Road Karachi 3 Tel: 51027, 52927 Cable: COOPERATOR Karachi</p> <p>SINGAPORE Mechanical and Combustion Engineering Company Ltd. 9, Jalan Kilang Singapore, 3 Tel: 642361-3 Cable: MECOMB Singapore</p> <p>SOUTH AFRICA F. H. Flanter & Co. (Pty.), Ltd. Rosella House Buitencingle Street Cape Town Tel: 3-3817 Cable: AUTOPHONE Cape Town</p>	<p>F. H. Flanter & Co. (Pty.), Ltd. 104 Pharmacy House 80 Jorissen Street Braamfontein, Johannesburg Tel: 724-4172</p> <p>TAIWAN Hwa Sheng Electronic Co., Ltd. P. O. Box 1558 21 Nanking West Road Taipei Tel: 46076, 45936 Cable: VICTRONIX Taipei</p> <p>THAILAND The International Engineering Co., Ltd. P. O. Box 39 614 Sukhumvit Road Bangkok Tel: 913460-1-2 Cable: GYSOM Bangkok</p> <p>VIETNAM Landis Brothers and Company, Inc. P.O. Box H-3 216 Hien-Vuong Saigon Tel: 20.805 Cable: LANBROCOMP Saigon</p>
--	--	---	--	--	---

FOR AREAS NOT LISTED, CONTACT: Hewlett-Packard Export Marketing; 1501 Page Mill Road; Palo Alto, California 94304; Tel: (415) 326-7000; Telex: 034-8461; Cable: HEWPACK Palo Alto