

**CALIBRATION OF A
GAMMA RAY SPECTROMETER**

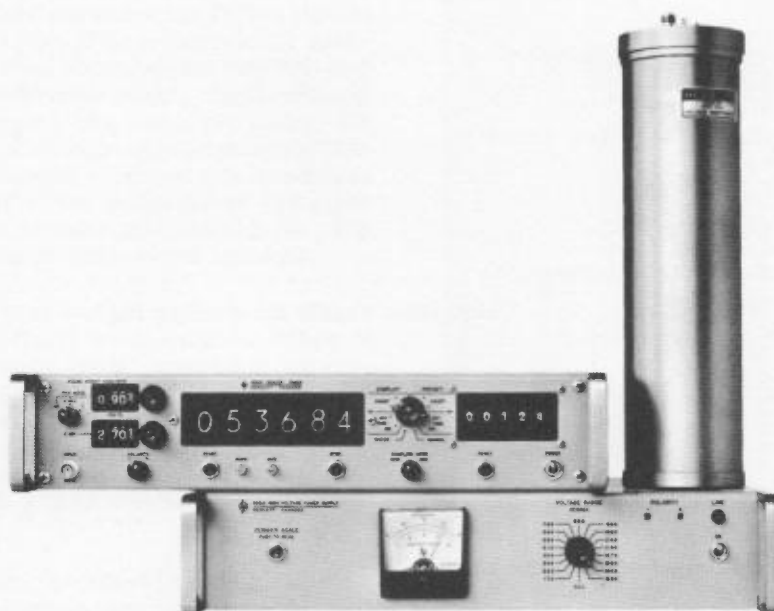

**APPLICATION NOTE 73
HEWLETT PACKARD CO.**

CALIBRATION OF A GAMMA RAY SPECTROMETER



FREQUENCY AND TIME DIVISION, PALO ALTO, CALIFORNIA, U.S.A.

COPYRIGHT

HEWLETT  PACKARD

1966

TABLE OF CONTENTS

INTRODUCTION	1
GAMMA RAY SPECTROMETER	3
Scintillation Detector	3
Photomultiplier Tube High Voltage Setting	3
Amplifier.	3
Pulse Height Analyzer.	4
Scaler-Timer	4
Gamma Ray Spectrometry	5
CALIBRATION	7
General	7
Equipment Arrangement	7
Determination of the Calibration Factor for a Given High Voltage Setting	7
Calibration to a Selected Range of Gamma Ray Energy	9
Graphical Estimation of High Voltage Setting	10
Calibration Procedure Check List	11
APPENDIX	A-1

CALIBRATION OF A GAMMA RAY SPECTROMETER

INTRODUCTION

A Hewlett-Packard 5201L Scaler-Timer, a 5551A High Voltage Power Supply, and any one of the Series 10600A Scintillation Detectors constitute a gamma ray spectrometer. This application note presents step-by-step procedures for the calibration of this single-channel spectrometer to the range of gamma ray energy the user selects. While the details relate specifically to the spectrometer discussed, the basic relationships and the manner in which the calibrations are made apply also to systems based upon ratemeters. The general approach is that of differential counting.

Gamma ray spectrometry has grown from small beginnings around 1950 until today large catalogs of gamma ray spectra cover most isotopes of importance to areas such as nuclear reactor operation and nuclear physics research. Uses for gamma ray spectra include identification of unknown isotopes and quantitative measurement by comparison of photopeak counts in the unknown and in a calibrated sample of the same isotope.

The scintillation detector's high efficiency for gamma rays makes it suitable for measurements on low activity gamma-emitting sources. This capability leads to numerous applications in areas such as radiochemistry, clinical medicine (diagnostic work with tracers), biomedical research, geology, meteorology, and metallurgy.

Figure 1 shows a gamma ray spectrum for cesium-137 obtained with a Hewlett-Packard scintillation spectrometer. The prominent photopeak corresponds to the 662 keV gamma ray which characterizes this isotope. Cs-137, which is readily available and has a relatively simple spectrum, is often used to calibrate gamma ray spectrometers.

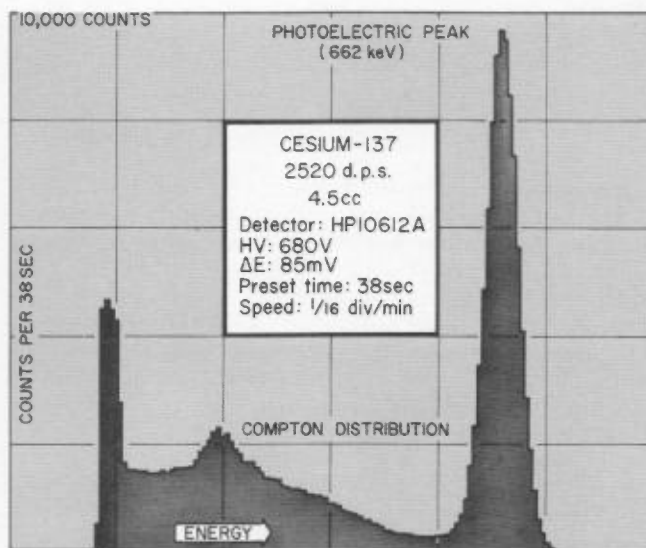

Figure 1. Gamma spectrum for cesium-137

A concise description of the functions essential to a gamma ray spectrometer follows next for use by those readers who may wish to review these functions from the standpoint of the Hewlett-Packard system, before reading the detailed calibration procedures. These procedures are followed by a check list which is a summary that includes only those details the experienced user will want for reference. An appendix gives instrument details: front and rear panel views and operating instructions.

GAMMA RAY SPECTROMETER

Two of the essential functions of a gamma ray spectrometer, to detect gamma rays and to measure their energies, are performed in the scintillation detector and in the pulse height analyzer.

SCINTILLATION DETECTOR

The scintillation detector has three parts: (1) the scintillation phosphor crystal (usually thallium activated sodium iodide), (2) the photomultiplier tube, and (3) the amplifier. Figure 2 shows a block diagram. Gamma rays from the gamma emitter to be measured enter the detector and traverse the scintillation crystal, giving up their energy in exciting and ionizing its atoms. These excited atoms then radiate energy as flashes of light. Each group of flashes (scintillations) is nearly proportional to the energy of the incident gamma ray absorbed in the crystal. The light passes through the transparent crystal and some of it is received at the photocathode, where it ejects electrons. In the photomultiplier tube, these electrons are accelerated to the first of a series of dynodes. The electrons which strike each dynode produce many more electrons by secondary emission, a progressive effect which builds into a multiplication factor of about 10^5 , yet maintains proportionality. The photomultiplier anode collects the resulting burst of charge, which is delivered through the output capacitor to the amplifier input. The charge is integrated and amplified to produce a voltage step, then it is differentiated (clipped) to produce a pulse of optimum shape for input to the pulse height analyzer. Throughout the entire process, the proportionality to the energy of the incident gamma ray is closely maintained. Thus, a single gamma ray's energy is transformed into a single voltage pulse suitable for measurement.

PHOTOMULTIPLIER TUBE HIGH VOLTAGE SETTING

A change in the voltage provided by the high voltage supply to the photomultiplier tube changes the output signal amplitude; an increase in voltage to the photomultiplier's dynodes causes an increase in the amplitude of the output pulse for a given gamma ray energy. This effect is used to adjust the system for measurements of gamma rays within a selected energy range. That is, by selection of the high voltage setting, pulse amplitudes within the range acceptable to the system can be made to correspond to gamma ray energies in, say, the range of thousands of electron volts* (keV) or of millions of electron volts (MeV).

AMPLIFIER

It is necessary to convert the output current pulses from the photomultiplier into voltage pulses and to amplify and shape these pulses so that they are suitable for triggering the scaler-timer circuits. The Hewlett-Packard detector uses a charge-sensitive preamplifier with a conversion gain of approximately 25 picocoulombs per volt. The subsequent amplifiers have a voltage gain of 10 or 100. The gain of these amplifiers and that of the photomultiplier must be considered in the calibration of the spectrometer.

*Note: The electron volt is an energy unit, the energy gained by an electron in passing through a potential difference of one volt: $1 \text{ eV} = 1.6 \times 10^{-12} \text{ erg}$, keV = kilo-electron volt, MeV = million-electron volt.

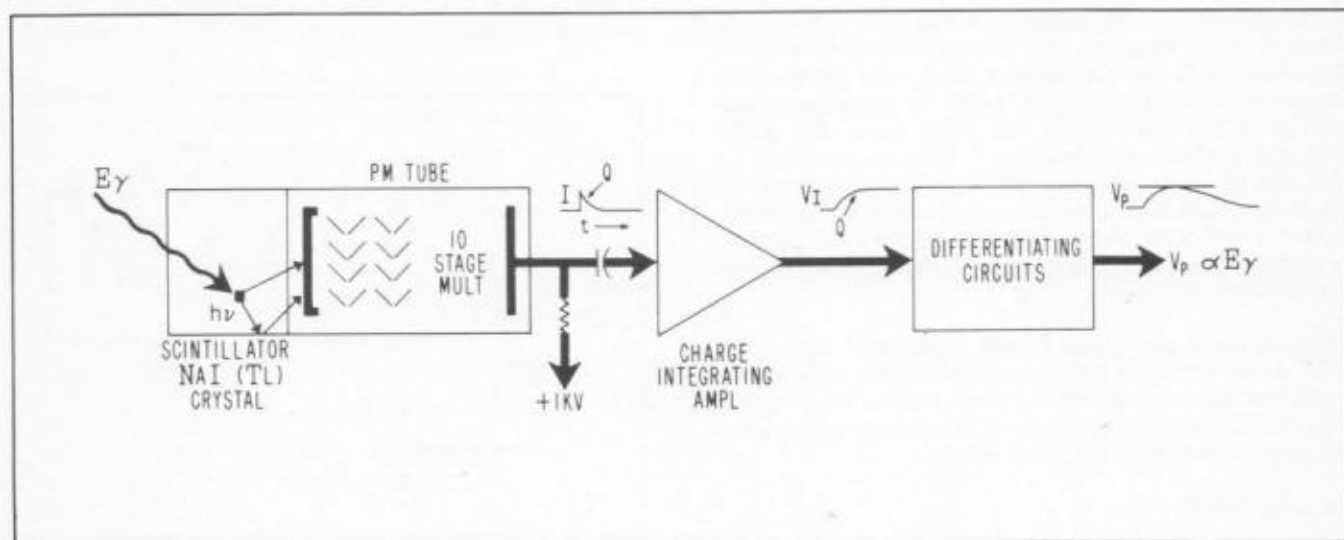

Figure 2. Scintillation detector block diagram

PULSE HEIGHT ANALYZER

The single-channel pulse height analyzer sorts the pulses from the scintillation detector according to amplitude, passing those lying between two preselected limits to the scaler-timer and discriminating against others.

Each input pulse is presented to a pair of discriminators, referred to as the lower level discriminator and the upper level discriminator; E_{min} and E_{max} are the energies to which the trigger levels of these discriminators correspond. These two limits define a "window" or "channel" corresponding to an energy band of width ΔE . To understand the action of these discriminators, consider three cases where: (1) the pulse height is less than the preset value of E_{min} , (2) the pulse height is greater than E_{min} but less than E_{max} , and (3) the pulse is greater than both. Figure 3 diagrams these pulses and shows their relationship to a typical spectrum.

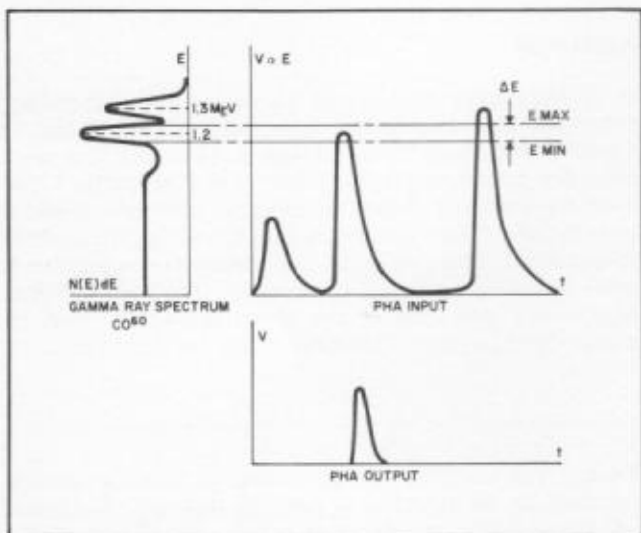

Figure 3. Differential pulse height discrimination

In the first case, the pulse is not propagated farther since it is not large enough to trigger the lower level discriminator. In the second case, the pulse falls within the ΔE window; this pulse is propagated and passed to the scaler. In the third case, the pulse triggers both discriminators. This large pulse is propagated to an anticoincidence circuit so designed that when pulses are received from both discriminators in time coincidence, both are blocked and no output pulse is passed to the scaler. Figure 4 shows the signal input.

The action of the pulse height analyzer, then, has been to discriminate against pulses larger or smaller (differential discrimination) than pulses of the predetermined size. These selected pulses are transmitted to the scaler for totalization.

SCALER-TIMER

The scaler-timer accumulates and stores pulses in digital form. The scaler can totalize the pulses dur-

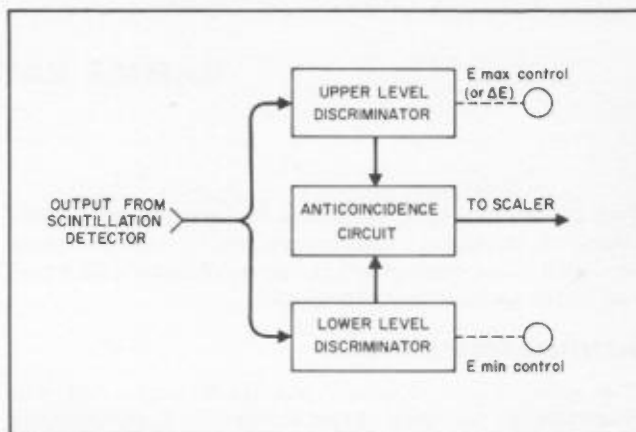

Figure 4. Pulse height analyzer block diagram

ing a precisely defined time period. Since scaler-timer input can reach hundreds of thousands of pulses each minute, the scaler must be capable of high speed counting. Operation can be set for predetermined count or for predetermined time.

To enter the scaler's first decimal counter assembly (DCA), the signal from the pulse height analyzer must pass the decimal counter assembly gate. This DCA gate may be enabled or disabled by either manual control (front panel pushbuttons), built-in timer control, or external control (another scaler, external timer, or other device). Figure 5 shows a block diagram of a Hewlett-Packard scaler. Each decimal counter assembly consists of four binary "flip-flops" (bistable multivibrator circuits) arranged in such a way that the DCA will put out one pulse for every ten pulses received. When the tenth pulse is received, the DCA (Decade) is reset to zero, and a pulse is sent to the next decade. This process is repeated down the line of decimal counting assemblies so that the record of the number of pulses received is stored by the decades. When the pulses to the decades are blocked (by disabling the DCA gate), the counting stops and the number of pulses accumulated is read out by a decoding arrangement into a visual numerical form (digital display tubes).

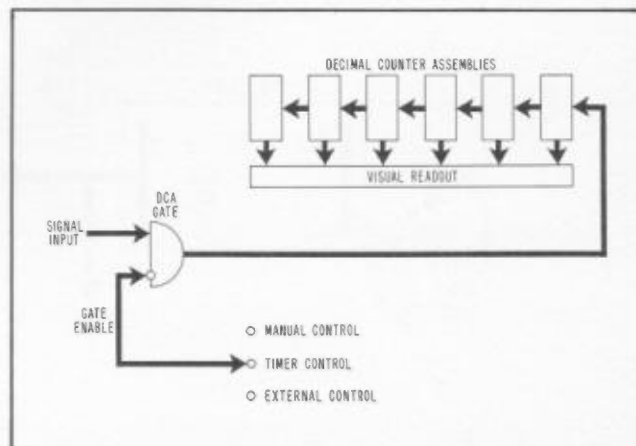

Figure 5. Scaler block diagram

GAMMA RAY SPECTROMETRY

A gamma ray spectrometer operating to perform pulse height analysis in the manner just described can give the data needed for plotting a gamma spectrum. With a single channel analyzer, a series of measurements are made on the isotope of interest by having the spectrometer totalize the count for a range of pulse heights corresponding to a narrow energy band; this count is repeated in turn for successive energy bands. Then, a plot of count rate vs pulse height (energy) constitutes the isotope's gamma ray spectrum.

To more conveniently and automatically obtain the data for a spectrum, a system which scans the energy range and records the data can be arranged as shown in Figure 6. In this HP system, the sweep input determines the value of E_{min} . The ΔE window formed by the E_{min} and E_{max} discriminators is moved through the complete voltage range by the sweep input to scan the spectrum automatically.

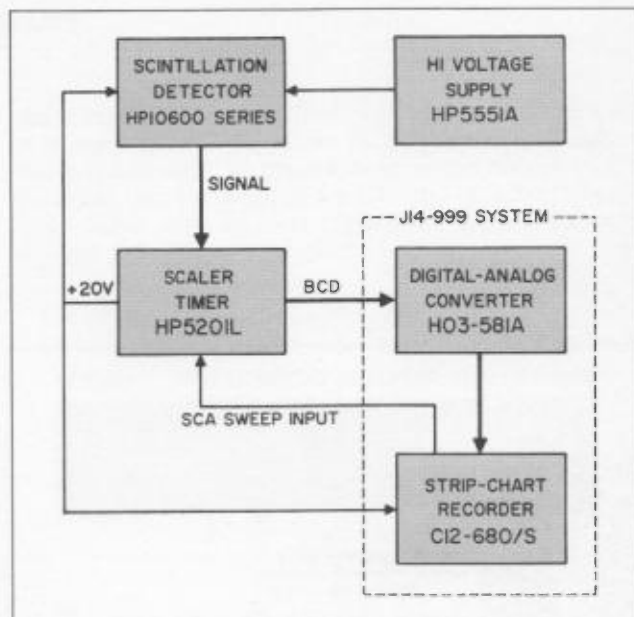

Figure 6. Scanning spectrometer block diagram

CALIBRATION

Gamma ray spectrometer calibration is basically a matter of establishing a known relationship between gamma ray energy (keV or MeV) and the discriminator scales (scale divisions or volts) so that pulse heights can be translated to energies.

The calibration procedure for the Hewlett-Packard 5201L Scaler-Timer, the 5551A High Voltage Supply, and one of the Scintillation Detectors, Series 10600A, will be set forth in detail.

For the convenience of those readers who are not completely familiar with the controls and operation of the HP instruments, the appendix presents information reproduced from their operating and service manuals. Front and rear panel views show all controls and terminals referred to in the calibration procedure, and charts outline basic instrument turn-on and operation.

GENERAL

The calibration factor for the HP 5201L can be expressed in terms of electron volts (keV or MeV) per volt or per scale division. To establish it, a sample having known gamma ray energy is measured.

Cesium 137, often used for this purpose, has a distinct photopeak at 662 keV and also a sharp peak at 31.5 keV (due to the barium-137 x-ray). A 0.5 microcurie Cs-137 source* was used throughout the calibration measurements to be described.

Calibration of the HP 5201L is made easy and quick by the automatic recycling mode and the storage display features exclusive with the HP Scaler-Timers. When a short preset time is selected, say 1 sec, then the measurement for that period is held and displayed during the next counting period. This display makes it easy for the user to observe the count rate while he is adjusting other controls accordingly.

First to be discussed is the determination of the calibration factor related to a given high voltage setting, and next, the procedure to set the voltage range of the discriminators (0 to 5 volts) to cover a selected gamma ray energy range (say, 0 to 1 MeV; calibration factor, 0.2 MeV per volt). Finally, a graphical method to estimate the high voltage setting appropriate to a given energy range is described. The user may select from these methods the particular calibration best suited to his purpose.

EQUIPMENT ARRANGEMENT

Figure 7 is a block diagram indicating the connection of the 5201L, the 5551A, and the 10613A. Any one of

the Series 10600A scintillation detectors could be used. A source giving 10,000 to 20,000 counts per second (integral counts) is placed next to the detector or is inserted into the well, if a well-type detector is used. This same arrangement applies for each of the calibration procedures to follow.

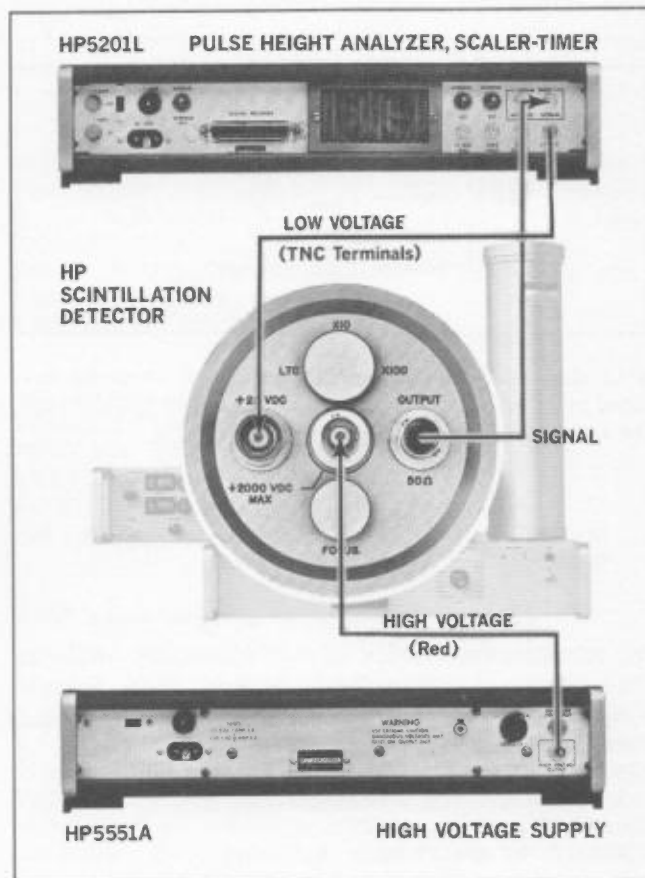

Figure 7. Block diagram, HP system for gamma ray spectrometry (single channel analyzer)

DETERMINATION OF THE CALIBRATION FACTOR FOR A GIVEN HIGH VOLTAGE SETTING

It is convenient to know the calibration factor (keV or MeV per volt) relative to one of the 85-volt steps which may be selected by use of the VOLTAGE RANGE SELECTOR on the front panel of the 5551A High Voltage Power Supply because the user can quickly and accurately reset to this same point, once it has been established.

The equipment arrangement is that shown in Figure 7. The procedure to be followed is simple. First, with the 5201L in integral mode, the gain is adjusted to bring the 662 keV photopeak of Cs-137 (or a selected

*Well-type lucite-enclosed source made by Hazleton Nuclear Science Corporation.

peak of known standard) within range of the discriminators. Next, with the 5201L in ΔE (narrow-window) mode, the operator locates the energy peak accurately by advancing E_{min} (the lower level discriminator) until the count rate is a maximum. A quick computation then gives the calibration factor.

When the 5201L's pulse height analyzer is operated in the ΔE mode, the upper level discriminator control sets and holds constant the desired window width (ΔE), the lower level discriminator sets E_{min} , and ΔE is referenced to E_{min} . At the selected value of E_{min} , all pulses with heights between E_{min} and $E_{min} + \Delta E$ will be passed to the scaler-timer and totalized. The mid-window reference is exactly given by $E_{min} + \frac{\Delta E}{2}$:

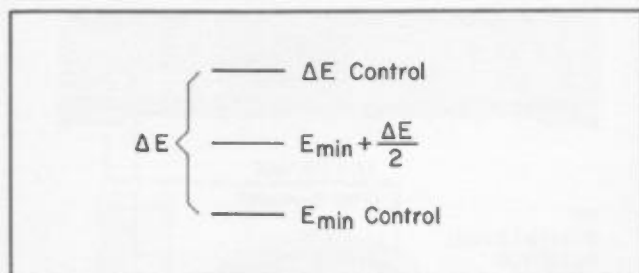

It is this mid-window reference which is to be related precisely to an energy peak in order to calibrate the spectrometer.

Procedure

1. Set controls as follows (refer to the Appendix for details):

<u>5201L</u>	<u>Rear Panel</u>
AC POWER: On	STORAGE: Normal
PHA MODE: \int (Integral)	E_{min} BIAS: Normal
E_{min} : 4.5 volts	GATE: Normal
POLARITY: +	
DISPLAY-PRESET:	
Display Count - Preset Time, sec	
SAMPLING MODE: Auto	
PRESET "N" SWITCHES: 1.0 (sec)	

5551A

POLARITY (Rear Panel): +
 VOLTAGE RANGE: 680 volts
 VERNIER: Fully counterclockwise
 AC POWER: On

Note: settings for VOLTAGE RANGE and E_{min} are examples, not fixed values applicable in all cases.

10613A

GAIN: X10 (or X100 as desired)

Note: the calibration is valid only for the gain (X10 or X100) used during calibration.

2. Increase the high voltage in 85-volt steps by clockwise resets of the VOLTAGE RANGE control. (Keep the VERNIER control switched out by turning it fully counterclockwise; it is not used in this procedure.) At each new voltage setting, observe the count. Note

the setting where there is a sudden increase in the number of counts. For example, the observations might be as follows:

<u>High Voltage</u>	<u>Counts per sec</u>
765 (volts)	1
850	1
935	1
1020	2
1105	11
1190	1700

The actual count depends upon a number of factors including source strength and geometry. The significant observation is the large jump in count rate rather than count value. The operator now knows that at $E_{min} = 4.5$ volts and with the VOLTAGE RANGE selector set at 1105 volts, the 662 keV energy peak is within range. It remains to measure this peak and to determine the calibration factor.

3. Leaving the VOLTAGE RANGE set at 1105 volts, change PHA MODE to $\Delta E = 0.100$ volt and change the preset "N" switches to 5.0 (sec). A longer count is needed since use of the narrow window mode will reduce the count rate. Reset E_{min} to a level somewhat below 4.50 volts and observe the count as it is progressively raised in 0.10 volt steps, for example:

<u>E_{min}</u>	<u>Counts per 5 sec</u>
4.10	908
4.20	1512
4.30	1771
4.40	1255
4.50	635
4.60	194

The maximum count is observed to be at $E_{min} = 4.30$ volts.

Note

During any count accumulation period when either the high voltage setting or one of the discriminators is changed, the count displayed is apt to be in error. After making any change, therefore, press the RESET button.

4. Compute the Calibration Factor, MeV/volt:

$$\begin{aligned}
 \text{C. F., MeV/volt} &= \frac{\text{Energy Peak, MeV}}{E_{min}, \text{ volts} + \frac{\Delta E, \text{ volts}}{2}} \\
 &= \frac{0.662}{4.30 + \frac{0.10}{2}} = \frac{0.662}{4.35} \\
 &= 0.15 \text{ MeV/volt}
 \end{aligned}$$

5. Find the 0-5 volt calibration range:

$$5 \text{ volts} \times 0.15 \frac{\text{MeV}}{\text{volt}} = 0.750 \text{ MeV}$$

Range: 0 to 750 keV.

The gamma ray spectrometer is now calibrated. Provided that the VOLTAGE RANGE control is reset to the same value (and the scintillation detector's GAIN switch is set as it was during the calibration), $E_{\min} + \Delta E/2$ readings are now related precisely to gamma ray energies.

If a more accurate calibration is desired, the operator can improve counting statistics by taking a longer count at each E_{\min} setting and by interpolating between settings (the peak is known to be symmetrical at its top). When this longer procedure was followed for the example just presented, it was found that $E_{\min} = 4.275$ volts rather than 4.30 volts.

CALIBRATION TO A SELECTED RANGE OF GAMMA RAY ENERGY

A useful and convenient gamma ray spectrometer calibration is to have the 0-5 volt range of the lower level discriminator correspond to a gamma ray energy range, say 0-1 MeV. Once this correspondence has been established, the odometer-type scale of the lower level discriminator can be interpreted in terms of gamma ray energy by a simple multiplication of the indicated scale reading by the calibration factor.

As in the method described earlier, a point connecting the two scales is found by measurement of a known standard. When Cs-137 is the standard used, the 662 keV peak is the reference which is positioned within the 0-5 volt range such that this peak lies at the midpoint of the ΔE window, and this midpoint is located at 662/1000 of its total travel:

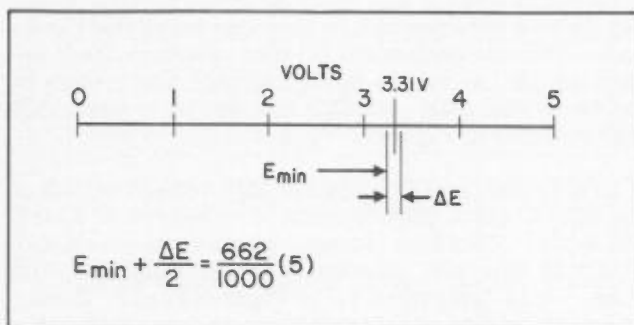

Suppose we select $\Delta E = 0.10$ volts, a width broad enough so that count rate with a 1 microcurie source will permit rapid observation, yet a width narrow in comparison to that of the photopeak. The lower level discriminator voltage is then computed to be 3.26 volts.

$$E_{\min} = \frac{662}{1000} (5) - \frac{0.10}{2} = 3.31 - 0.05 = 3.26 \text{ volts.}$$

The actual count rate maximum is the point where the window straddles the 662 keV energy peak, and it is this point which is the desired reference connecting the lower level discriminator's voltage scale and the gamma ray energy scale.

The 5201L's discriminators are extremely stable with both temperature and line voltage variation. The change in the input discriminator (over its full scale)

will be less than $0.01\%/^{\circ}\text{C}$ for a temperature range of $0-55^{\circ}\text{C}$ and for a line voltage variation of $\pm 10\%$ from 115 or 230 volts. After the initial voltage-energy calibrations are made for a particular measurement setup, this stability assures highly accurate day-to-day measurements.

The detailed procedure that follows will describe how the system gain is adjusted to accomplish the desired calibration. As before, the equipment arrangement is that shown in Figure 7, and the first step is to bring the 662 keV peak within range of the discriminators.

Procedure

1. Set controls as follows (see Appendix for front and rear panel views):

<u>5201L</u>	<u>Rear Panel</u>
AC POWER: On	STORAGE: Normal
PHA MODE: \int (Integral)	E_{\min} BIAS: Normal
E_{\min} : 3.26 volts	GATE: Normal
POLARITY: +	
DISPLAY-PRESET: Display Count -Preset Time, sec	
SAMPLING MODE: Auto	
PRESET "N" SWITCHES: 1.0 (sec)	

<u>5551A</u>
POLARITY (Rear Panel): +
VOLTAGE RANGE: 765
VERNIER: Fully counterclockwise
AC POWER: On

<u>10613A</u>
GAIN: X10 or X100, as desired.

Note: the calibration is valid only for the gain setting used during calibration.

2. Increase the high voltage in 85-volt steps by clockwise resets of the VOLTAGE RANGE control (keep the VERNIER fully counterclockwise, at which position it is switched out.) At each new voltage setting, observe the count. Note the voltage where there is a sudden increase in the number of counts. For example, the observations might be as follows:

<u>High Voltage</u>	<u>Counts per sec</u>
765	1
850	2
935	2
1020	31
1105	3165

The actual count depends upon a number of factors including source strength, geometry, and gain setting; the significant observation is the large jump in count rather than count value. The operator now knows that with the high voltage set somewhere between 1020 and 1105 volts, the photopeak will lie at the desired position. He should now refine the high voltage setting by use of the 5551A's VERNIER control and the 5201L's PHA ΔE MODE.

3. Reset the VOLTAGE RANGE control to 1020 and the PHA MODE switch to $\Delta E = 0.100$ volts. Rotate the VERNIER slowly clockwise to increase the high voltage, watching for the sudden jump in count and for the maximum count rate. Where this occurs, read the high voltage by pressing the VERNIER SCALE pushbutton (refer to the Appendix for details). Note this high voltage reading: 1092 volts.

4. Try another pass to more precisely determine this high voltage, increasing the time of each count to reduce statistical error.

Note

During any count accumulation period when either the high voltage setting or one of the discriminators is changed, the count displayed is apt to be in error. When the VERNIER SCALE pushbutton is depressed, the high voltage may be perturbed and noise may be introduced, also leading to a possible count error. Therefore, in such cases, press the RESET button.

Change the preset "N" switches to 5.0 (sec). Read the count at each of three 2-volt increments, for example:

High Voltage	Counts per 5 sec
1090	7864
1092	8412
1094	7953

Since the count maximum is found at 1092 volts, it is confirmed that the photopeak has been observed. Should this maximum count not lie at the middle reading of the three, repeat Steps 3 and 4. Note the exact high voltage setting where the maximum count rate is found.

5. Make a final recheck of the calibration by setting the high voltage at the level just determined and observing the count at three values of E_{\min} centered on the predicted value, 3.26 volts.

E_{\min}	Counts per 5 sec
3.21	7626
3.26	8450
3.31	7953

Since the maximum lies at the predicted value, 3.26 volts, the calibration is confirmed. If this is not the case, the operator should repeat steps 3, 4, and 5 with a new predicted value for E_{\min} based upon the observations just made.

The result of this procedure is that the gamma ray spectrometer is now calibrated over the range of gamma ray energies 0-1 MeV. The calibration factor is 0.2 MeV per volt.

This same basic procedure can be adapted for the establishment of other calibration factors, for example, 0.3 MeV per volt, 1.5 MeV full scale. Also, standards other than Cs-137 can, of course, be used.

With the high voltage set to the value determined, and with the scintillation detector's gain (X10 or X100) at the same setting used during the calibration procedure, the odometer scale of the lower level discriminator can now be interpreted in terms of gamma ray energy. Suppose it is desired to identify an energy peak of an unknown isotope. The user determines the energy of this peak by locating the mid-window reference where the count is a maximum, and then simply multiplies by the calibration factor.

GRAPHICAL ESTIMATION OF HIGH VOLTAGE SETTING

The high voltage setting which will calibrate the 5201L's discriminators to a desired range of gamma ray energy can be estimated to within ± 10 percent by use of the graphs presented in Figures 8 and 9. Figure 8 applies to energy ranges from about 1 MeV up to 10 MeV, while Figure 9 is useful for lower energies up to about 500 keV.

These plots relate high voltage settings (volts, horizontal axis) to full scale gamma ray energies (MeV or keV, right-hand vertical axis) and to calibration factors (MeV/volt, left-hand vertical axis). The slope each plot displays is the average of a number of determinations made with Hewlett-Packard scintillation detectors. Slope variations were found to be small, an indication of the desirability of the selection of premium photomultiplier tubes.

These graphs are general to the Series 10600A Scintillation Detectors and must be made specific to the user's own detector before they can serve their purpose. This the user accomplishes by determining for each graph the values of high voltage which apply to the horizontal axis. How this is done will be described with relation to Figure 8.

It first is necessary to find the high voltage setting of the 5551A which corresponds to an energy of 5 MeV full scale. This high voltage, which varies from detector to detector, usually is in the range 500-700 volts. It is designated V_C on Figures 8 and 9. It may be determined by use of the procedure described under "Calibration to a Selected Range of Gamma Ray Energy". The predicted value of E_{\min} to place the Cs-137 peak at the desired mid-window reference is 0.612 volt for $\Delta E = 0.1$ volt:

$$E_{\min} = \frac{5(0.662)}{5} - \frac{\Delta E}{2} = 0.662 - 0.05 = 0.612 \text{ volt}$$

The value of the high voltage setting which has been determined is now substituted for V_C on the graph's high voltage scale, horizontal axis. The other major graduations of this scale become $V_C \pm 100$, $V_C \pm 200$, etc. For example, suppose $V_C = 570$ volts. The major graduations relative to this value would become 370, 470, 570, 670, and 770 volts.

An example set out with a dashed line makes clear how the graph is used. Assume the user desires to set a spectrometer to cover the gamma ray energy range 0-1.5 MeV. He has found that $V_C = 520$ volts. He

enters the graph at 1.5 MeV along the right-hand vertical scale, traces straight left to the diagonal line, and from this intercept straight down to the horizontal scale where he reads the desired value to be 643 volts (520 + 123).

The graph's left-hand vertical scale shows the calibration factors corresponding to the full scale gamma ray energies on the right-hand scale and is useful to estimate a calibration factor for a known high voltage setting.

Figure 9 shows the graph for use at lower gamma ray energies; it serves the same purpose as Figure 8, for energy ranges from 0-60 keV up to 0-600 keV. To gain accuracy for this lower energy range, the 31.5 keV

peak of Cs-137 is used as the reference. The procedure for establishing the value of V_C is otherwise the same as discussed earlier. Again, the predicted value for E_{min} is 0.612 volt with ΔE at 0.1 volt.

Since these graphs were prepared with the GAIN switch of the Series 10600A Scintillation Detector set at X100, they apply only for a X100 setting. Note that V_C must be redetermined if the photomultiplier tube is changed.

CALIBRATION PROCEDURE CHECK LIST

The steps necessary to calibrate the 5201L, the 5551A, and any one of the Series 10600A Scintillation Detectors are summarized on the pages to follow. Users may wish to reproduce these two pages for use as a check-off card.

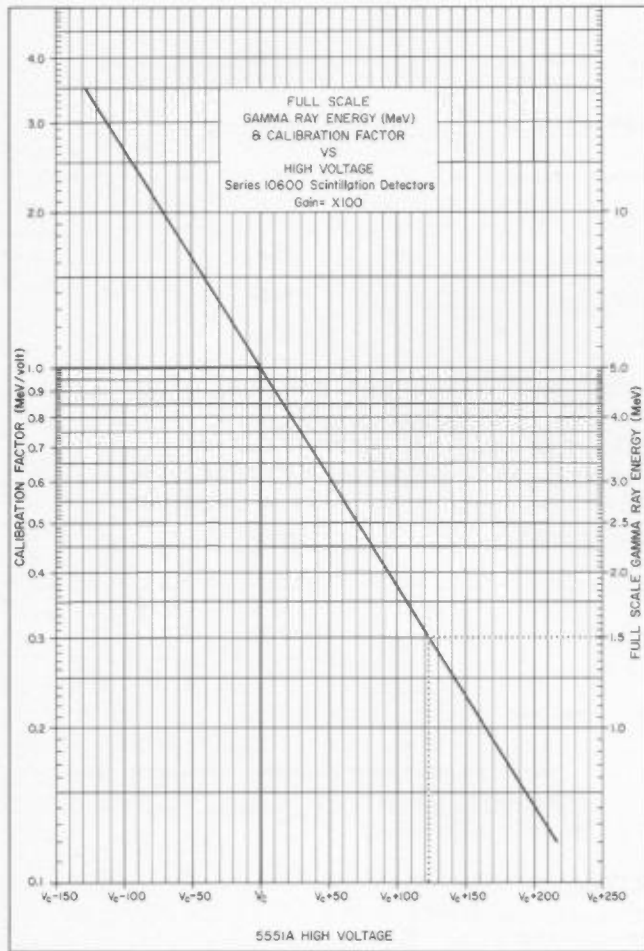

Figure 8. Relationship of full-scale gamma ray energy (MeV), calibration factor, and high voltage. The value of V_C (typically 500-700 volts) that applies to the horizontal axis must be found for the photomultiplier-detector being used (see text). The 662 keV peak of Cs-137 is the energy reference.

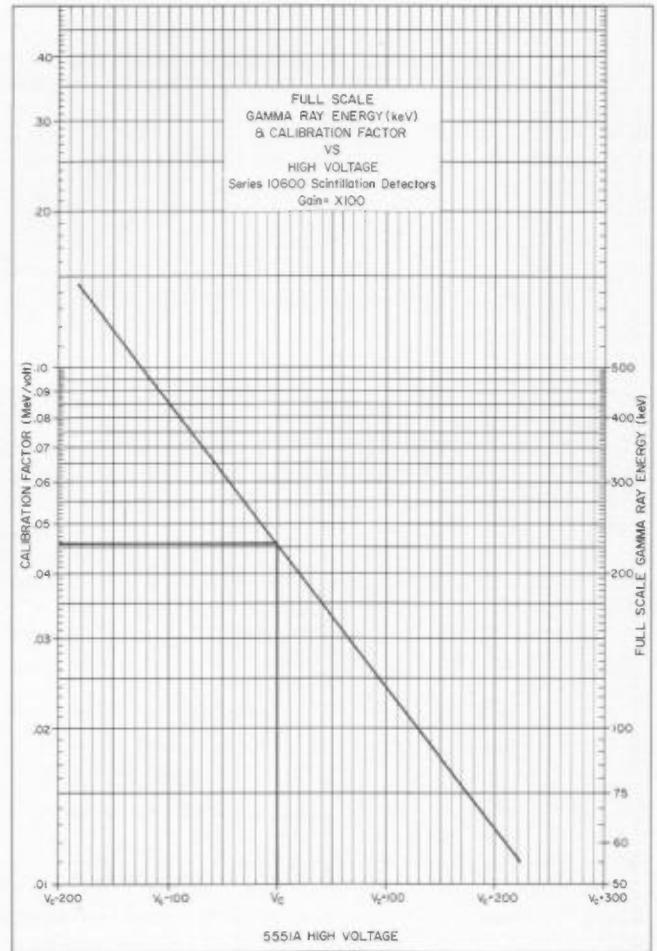

Figure 9. Full-scale gamma ray energy (keV) and calibration factor vs high voltage. V_C must be found for the photomultiplier-detector being used (see text). The 32 keV peak of Cs-137 is the energy reference.

CHECK LIST

CALIBRATION FACTOR, GIVEN HIGH VOLTAGE SETTING

SYSTEM COMPONENTS: 5201L SCALER-TIMER, 5551A HIGH VOLTAGE POWER SUPPLY, SERIES 10600A SCINTILLATION DETECTOR.

1. SET CONTROLS AS FOLLOWS:

<u>5201L</u>		<u>REAR PANEL</u>
AC POWER:	ON	STORAGE: NORMAL
PHA MODE:	\int (INTEGRAL)	E_{MIN} BIAS: NORMAL
E_{MIN} :	4.5 VOLTS	GATE: NORMAL
POLARITY:	+	
DISPLAY-PRESET:	DISPLAY COUNT - PRESET TIME, SEC	
SAMPLING MODE:	AUTO	
PRESET "N" SWITCHES:	1.0 (SEC)	

<u>5551A</u>		<u>10613A</u>
POLARITY (REAR PANEL):	+	GAIN SWITCH: X10 (OR X100)
VOLTAGE RANGE:	680	NOTE: CALIBRATION IS VALID
VERNIER:	FULLY COUNTERCLOCKWISE	ONLY FOR SETTING USED
AC POWER:	ON	DURING CALIBRATION.

2. INCREASE HIGH VOLTAGE BY CLOCKWISE STEPS OF THE **VOLTAGE RANGE** CONTROL, OBSERVING THE COUNT RATE TO FIND THE SETTING WHERE A SUDDEN INCREASE OCCURS. NOTE THIS VALUE.

<u>HIGH VOLTAGE</u>	<u>COUNTS PER SEC</u>	
765 VOLTS	_____	
850	_____	
935	_____	
1020	_____	HI VOLTAGE _____
1105	_____	
1190	_____	

3. CHANGE **PHA MODE** TO $\Delta E = 0.100$ VOLT; CHANGE PRESET "N" SWITCHES TO 5.0 (SEC); RESET E_{MIN} SLIGHTLY BELOW INITIAL SETTING. INCREASE E_{MIN} IN 0.1 VOLT STEPS, WATCHING FOR THE MAXIMUM COUNT.

<u>E_{MIN}</u>	<u>COUNTS PER 5 SEC</u>
_____	_____
_____	_____
_____	_____
_____	_____

4. COMPUTE THE CALIBRATION FACTOR: CALIBRATION
 C.F., MEV/VOLT = $\frac{\text{ENERGY PEAK, MEV}}{E_{MIN} + \frac{\Delta E}{2}} \text{ VOLTS}$ HIGH VOLTAGE _____

-CALIBRATION-

DATE _____ INITIALS _____

CALIBRATION FACTOR _____

SPECTROMETER SERIAL NOS.

HP 5201L _____

HP 5551A _____

HP DETECTOR _____

GAIN _____

(X10 OR X100)

CHECK LIST

CALIBRATION TO A SELECTED RANGE OF GAMMA RAY ENERGY

1. PREDICT E_{MIN} TO CALIBRATE SPECTROMETER TO DESIRED ENERGY RANGE. FOR EXAMPLE, TO MAKE 0-5 VOLTS CORRESPOND TO 0-1 MEV WITH USE OF 662 KEV $Cs-137$ PEAK:

$$E_{MIN} + \frac{\Delta E}{2} = \frac{662}{1000} (5)$$

2. SET CONTROLS AS FOLLOWS:

5201L

AC POWER: ON
 PHA MODE: \int (INTEGRAL)
 E_{MIN} (PREDICTED VALUE) _____
 POLARITY: +
 DISPLAY - PRESET: DISPLAY COUNT - PRESET TIME, (SEC)
 SAMPLING MODE: AUTO
 PRESET "N" SWITCHES: 1.0 (SEC)

REAR PANEL

STORAGE: NORMAL
 E_{MIN} BIAS: NORMAL
 GATE: NORMAL

5551A

POLARITY (REAR PANEL) +
 VOLTAGE RANGE: 765
 VERNIER: FULLY COUNTERCLOCKWISE
 AC POWER: ON

10613A

GAIN: X10 OR X100, AS DESIRED.
 NOTE: THE CALIBRATION IS VALID ONLY FOR GAIN SETTING USED DURING CALIBRATION

3. INCREASE HIGH VOLTAGE BY CLOCKWISE STEPS OF THE **VOLTAGE RANGE** CONTROL, OBSERVING THE COUNT RATE TO DISCOVER THE SETTING WHERE A SUDDEN INCREASE OCCURS. NOTE THIS VALUE.

<u>HIGH VOLTAGE</u>	<u>COUNTS PER SEC</u>	
765	_____	
850	_____	
935	_____	
1020	_____	VOLTAGE RANGE _____
1105	_____	
1190	_____	

4. CHANGE PHA MODE TO $\Delta E = 0.100$ VOLT, RESET **VOLTAGE RANGE** ONE SETTING BELOW THAT FOUND IN STEP 2. ROTATE **VERNIER** SLOWLY CLOCKWISE, WATCHING FOR SUDDEN JUMP IN COUNT AND THE MAXIMUM COUNT RATE. AT THIS POINT, READ THE HIGH VOLTAGE (PRESS **VERNIER** SCALE PUSH-BUTTON).
5. TRY ANOTHER PASS TO MORE PRECISELY DETERMINE THIS HIGH VOLTAGE: CHANGE PRESET "N" SWITCHES TO 5.0 SEC. READ COUNT AT 2 VOLT INCREMENTS.

<u>HIGH VOLTAGE</u>	<u>COUNTS PER 5 SEC</u>
_____	_____
_____	_____
_____	_____

IF HIGHEST COUNT DOES NOT LIE AT CENTER READING OF THE THREE, REPEAT STEPS 4 & 5.

6. VERIFY THE CALIBRATION BY SETTING THE HIGH VOLTAGE AT THE VALUE JUST DETERMINED AND OBSERVING THE COUNT FOR THREE VALUES OF E_{MIN} CENTERED ON THE PREDICTED VALUE. IF CALIBRATION IS NOT CONFIRMED, REPEAT STEPS 4, 5, & 6. ENTER RESULTS IN BOX FOR FUTURE REFERENCE.

-CALIBRATION -	
DATE _____	INITIALS _____
ENERGY RANGE _____	
CALIBRATION FACTOR _____	
HIGH VOLTAGE _____	
SPECTROMETER SERIAL NOS.	
HP 5201L _____	
HP 5551A _____	
HP DETECTOR _____	
GAIN _____	
(X10 OR X100)	

APPENDIX

This appendix presents front and rear panel views for the Model 5201L Scaler-Timer and the Model 5551A High Voltage Power Supply, and operating details for those modes of operation referred to in the calibration procedures. Controls and terminals for one of the Series 10600A Detectors are also shown. Appendix material was reproduced directly from operating manuals, which should be consulted for any additional information wanted.

Model 5201L Scaler-Timer Front Panel

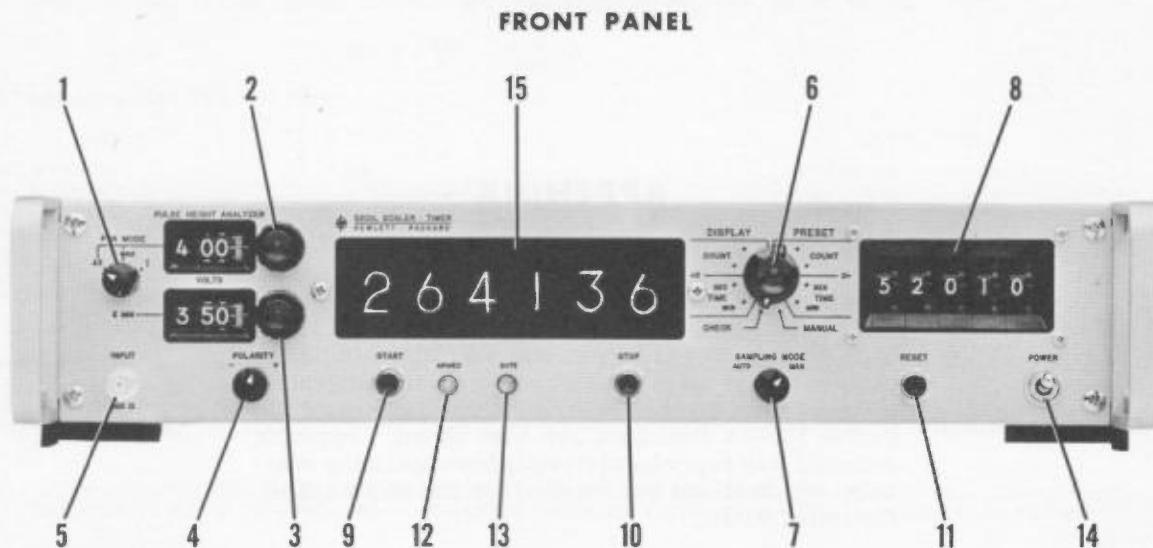

1. PHA MODE: selects the modes of pulse height analyzer operation: ΔE mode, E_{\max} mode, f mode.
2. UPPER LEVEL DISCRIMINATOR (ULD) CONTROL: 1) determines the window width (ΔE) in the ΔE PHA MODE, 2) sets the upper level E_{\max} PHA MODE, and 3) is off in the f PHA MODE. The ULD range is 0 to +.500V in ΔE PHA MODE and 0.05V to 5.0V in E_{\max} PHA MODE.
3. LOWER LEVEL DISCRIMINATOR (LLD) CONTROL: 1) determines the lower level of the window (E_{\min}) in the ΔE PHA MODE, 2) sets the lower level (E_{\min}) in the E_{\max} PHA MODE, and 3) determines the lower level in the f PHA MODE. The LLD range is 0.05V to 5.0V.
4. POLARITY: selects polarity of input pulses, facilitating operation with detectors providing either positive or negative output pulses.
5. INPUT 500 Ω . Front or rear panel signal INPUT. (5.0 volts max peak pulse amplitude.)
6. DISPLAY-PRESET: selects mode of measurement: CHECK, DISPLAY TIME MIN-PRESET COUNT, DISPLAY TIME SEC-PRESET COUNT, DISPLAY COUNT-PRESET TIME SEC, DISPLAY COUNT-PRESET TIME MIN, and MANUAL.
7. SAMPLING MODE: selects AUTOMATIC or MANUAL sampling. With AUTOMATIC sampling the Scaler-Timer continuously accumulates pulses, displays, resets and arms itself for the next gating pulse. With MANUAL sampling the RESET pushbutton must clear display, preset dividers, and clock time base; and the STOP and START pushbuttons control the accumulation of pulses.
8. PRESET "N" SWITCHES: select the numbers to be displayed in DISPLAY-PRESET CHECK. In DISPLAY TIME-PRESET COUNT the Scaler-Timer counts and displays the time in seconds or minutes required for a number of counts preset by the "N" switches to be made. In DISPLAY COUNT-PRESET TIME the Scaler-Timer counts the number of input pulses for a time in seconds or minutes preset by the "N" switches.
9. START: will start the count in DISPLAY-PRESET MANUAL function. In the MANUAL SAMPLING MODE, the START pushbutton arms the gate so the next gating pulse will start the count.
10. STOP: will stop the count in any mode of operation. In DISPLAY-PRESET functions the STOP pushbutton stops and resets the Scaler-Timer. In the MANUAL SAMPLING MODE the stop pushbutton stops the count but does not reset it. The count may be started again by the START pushbutton or reset by pushing the RESET pushbutton.
11. RESET: resets display, preset decades, and clock time base.
12. ARMED LAMP: indicates that the gate is armed and ready to receive a timing pulse.
13. GATE LAMP: indicates that the gate is open and the Scaler-Timer is counting.
14. AC POWER SWITCH: turns instrument on and off.
15. DISPLAY. The six Decimal Counter Assemblies provide the display of either; 1) the input signals in DISPLAY COUNT-PRESET TIME and DISPLAY COUNT-PRESET MANUAL functions, 2) the clock time base signals in DISPLAY TIME-PRESET COUNT function or, 3) the self check signals determined by the preset "N" switches in the DISPLAY PRESET CHECK functions.

Model 5201L Scaler-Timer Rear Panel

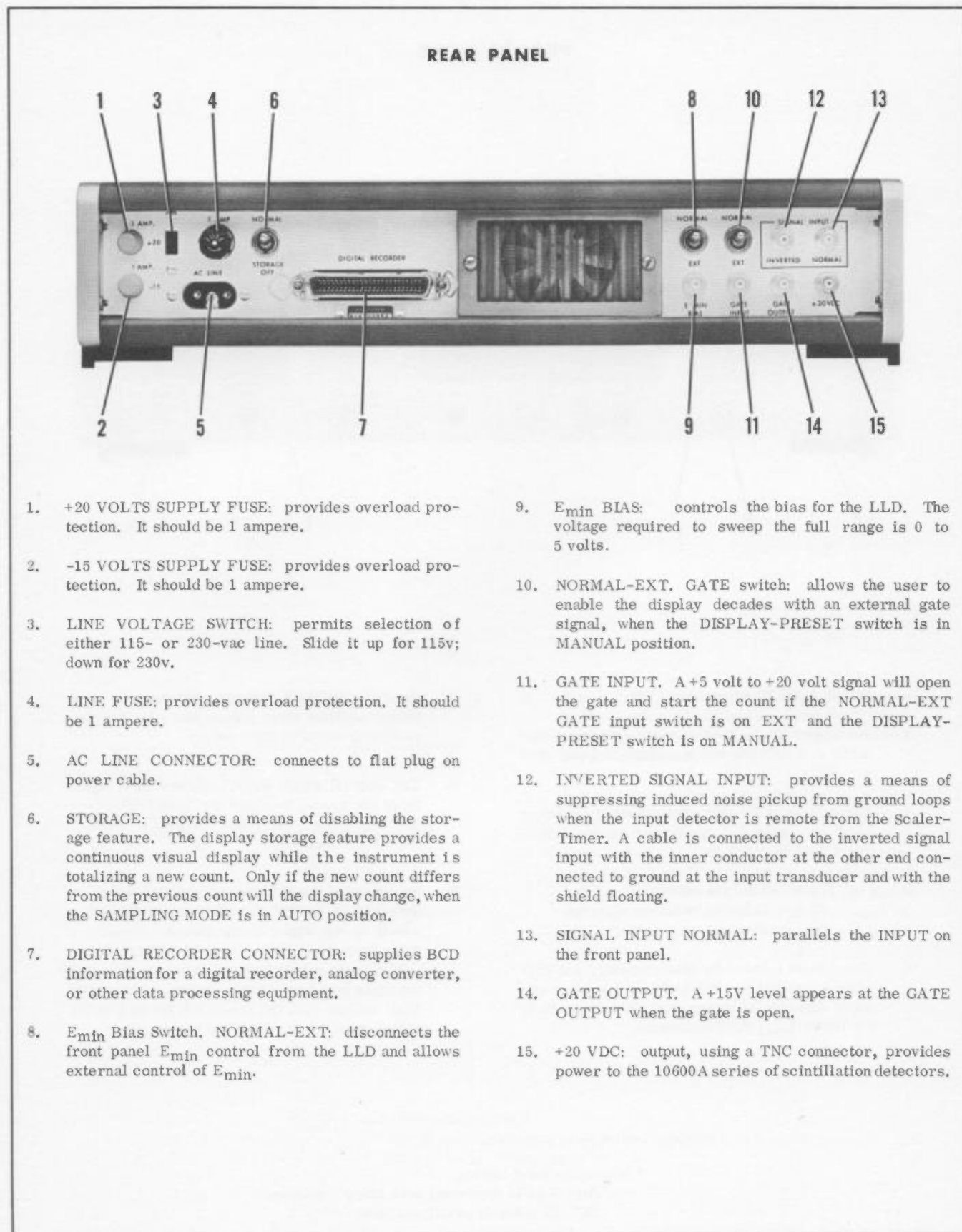

1. +20 VOLTS SUPPLY FUSE: provides overload protection. It should be 1 ampere.
2. -15 VOLTS SUPPLY FUSE: provides overload protection. It should be 1 ampere.
3. LINE VOLTAGE SWITCH: permits selection of either 115- or 230-vac line. Slide it up for 115v; down for 230v.
4. LINE FUSE: provides overload protection. It should be 1 ampere.
5. AC LINE CONNECTOR: connects to flat plug on power cable.
6. STORAGE: provides a means of disabling the storage feature. The display storage feature provides a continuous visual display while the instrument is totalizing a new count. Only if the new count differs from the previous count will the display change, when the SAMPLING MODE is in AUTO position.
7. DIGITAL RECORDER CONNECTOR: supplies BCD information for a digital recorder, analog converter, or other data processing equipment.
8. E_{min} Bias Switch. NORMAL-EXT: disconnects the front panel E_{min} control from the LLD and allows external control of E_{min} .
9. E_{min} BIAS: controls the bias for the LLD. The voltage required to sweep the full range is 0 to 5 volts.
10. NORMAL-EXT. GATE switch: allows the user to enable the display decades with an external gate signal, when the DISPLAY-PRESET switch is in MANUAL position.
11. GATE INPUT. A +5 volt to +20 volt signal will open the gate and start the count if the NORMAL-EXT GATE input switch is on EXT and the DISPLAY-PRESET switch is on MANUAL.
12. INVERTED SIGNAL INPUT: provides a means of suppressing induced noise pickup from ground loops when the input detector is remote from the Scaler-Timer. A cable is connected to the inverted signal input with the inner conductor at the other end connected to ground at the input transducer and with the shield floating.
13. SIGNAL INPUT NORMAL: parallels the INPUT on the front panel.
14. GATE OUTPUT. A +15V level appears at the GATE OUTPUT when the gate is open.
15. +20 VDC: output, using a TNC connector, provides power to the 10600A series of scintillation detectors.

Operation - Model 5201L Scaler-Timer

PHA ΔE MODE

1. Set PHA MODE selector to ΔE .
2. Set upper level discriminator control to desired ΔE (window width), range is from .000 to +.500v.
3. For use as a Manual Spectrometer set lower level for desired E_{min} (lower window level), range is 0.05v to 5.0v.

 Note: All pulses between E_{min} and $E_{min} + \Delta E$ will be totalized by the Scaler-Timer.
4. For use as a Scanning Spectrometer, set rear panel E_{min} BIAS switch to its EXT position and apply external scanning control voltage (0 to 5 volts) to E_{min} BIAS connector.
5. Set POLARITY switch to + for sources providing positive input pulses and - for sources providing negative input pulses.
6. For normal signal input: connect input signal from the source to either the front INPUT connector or the rear panel NORMAL SIGNAL INPUT connector. *
7. For guarded signal input: connect a cable from the SIGNAL INPUT NORMAL connector (rear panel) to the signal input source. Connect a cable from the SIGNAL INPUT INVERTED connector (rear panel) with the inner conductor at the other end connected to ground at the signal input source with the shield left floating at the signal source (not connected to ground). *

* Maximum Input Levels.

AC: 5 volts maximum peak pulse amplitude

DC: 25 volts dc maximum level

Operation - Model 5201L Scaler-Timer

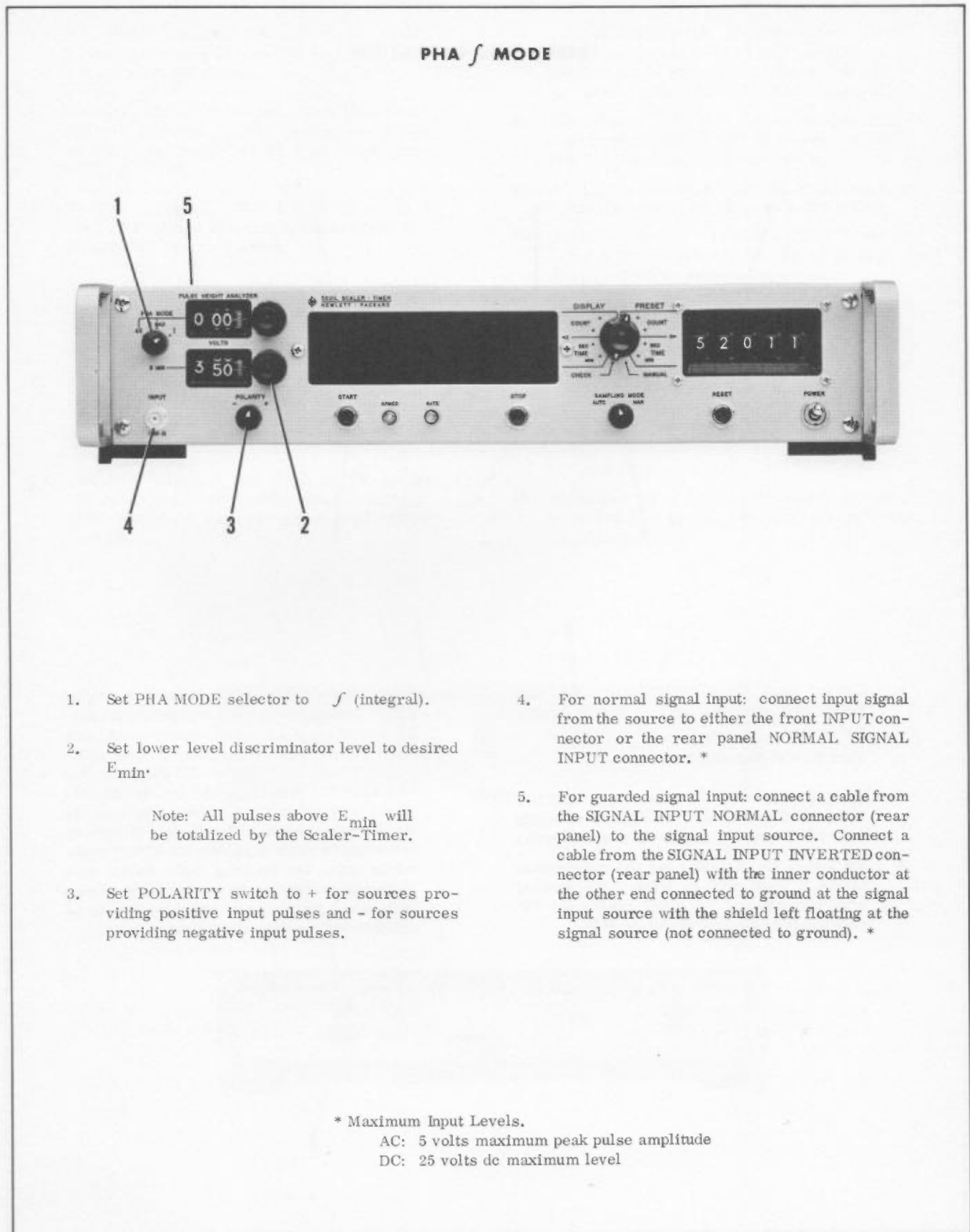

1. Set PHA MODE selector to \int (integral).
2. Set lower level discriminator level to desired E_{min} .
3. Set POLARITY switch to + for sources providing positive input pulses and - for sources providing negative input pulses.
4. For normal signal input: connect input signal from the source to either the front INPUT connector or the rear panel NORMAL SIGNAL INPUT connector. *
5. For guarded signal input: connect a cable from the SIGNAL INPUT NORMAL connector (rear panel) to the signal input source. Connect a cable from the SIGNAL INPUT INVERTED connector (rear panel) with the inner conductor at the other end connected to ground at the signal input source with the shield left floating at the signal source (not connected to ground). *

Note: All pulses above E_{min} will be totalized by the Scaler-Timer.

* Maximum Input Levels.

AC: 5 volts maximum peak pulse amplitude

DC: 25 volts dc maximum level

Operation - Model 5201L Scaler-Timer

PRESET TIME OPERATION

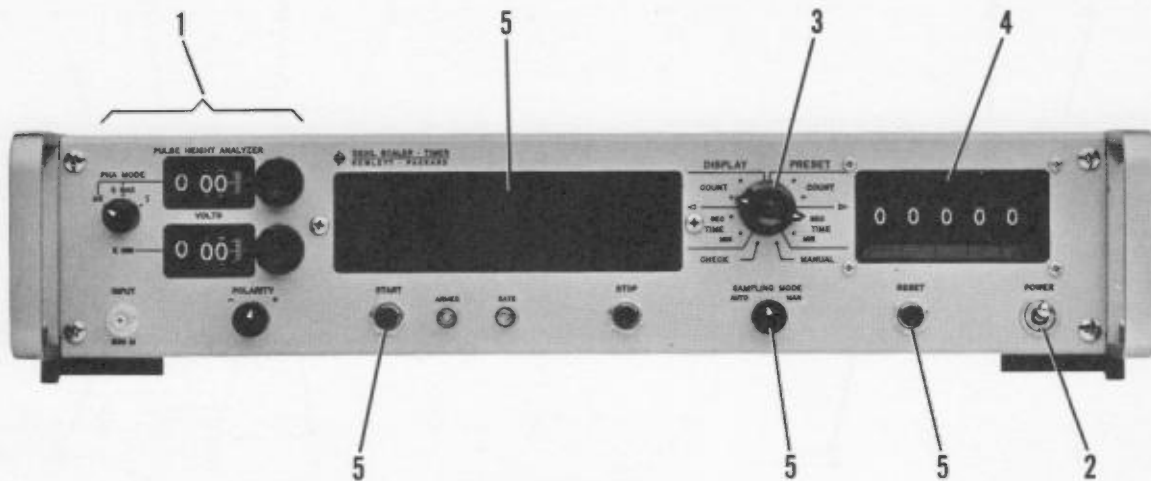

1. Connect input signal and set up desired Pulse Height Analyzer Mode as described in Figures 3-3 to 3-5.
2. Turn POWER selector to ON.
3. Set DISPLAY-PRESELECT selector to PRESET TIME (SEC or MIN). (The number of counts made for the preset period of time is displayed.)
4. Set preset "N" switches for desired counting period in time (SEC or MIN). The decimal point is positioned to permit reading the "N" switch setting directly in SEC or MIN.
5. Select desired SAMPLING MODE. In AUTO SAMPLING MODE the Scaler-Timer will totalize and display the count measurement, then reset and start the cycle again. In MAN SAMPLING MODE pushing the START pushbutton will start the counting cycle and the Scaler-Timer will totalize the display and hold the count measurement. The Scaler-Timer can now either be reset by pushing the RESET pushbutton and a new counting cycle started or a new counting cycle can be started without reset, in this case the new count measurement will be added to the previous count measurement.

Model 5551A High Voltage Power Supply - Front & Rear Panel Views

1. AC Power Switch. The ac power switch turns instrument ON and OFF. LINE indicator indicates ac power on.
2. Voltage Range Selector. The VOLTAGE RANGE selector selects the voltage range of the power supply in 85 volt steps from 170V to 1530V.
3. Vernier Control. The VERNIER control provides voltage adjustment between the 85V VOLTAGE RANGE steps.
4. Front Panel Meter. The front panel meter reads either the total power supply output voltage, or (with VERNIER SCALE pushbutton depressed) vernier supply voltage.
5. Vernier Scale Push to Read. Pressing the VERNIER SCALE pushbutton enables operator to read vernier supply voltage on front panel meter.
6. Polarity Lamps. The POLARITY lamps indicate the polarity of the output voltage, determined by the rear panel POLARITY switch.
7. Line Voltage Switch. The line voltage switch selects either 115-V or 230-V ac line; insert narrow blade and slide to the left for 115-V; or slide to the right for 230-V operation.
8. Line Fuse. The line fuse provides overload protection; should be 1 amp for 115V, and 1/2 amp for 230V operation.
9. AC Line Connector. The AC line connector connects to the flat plug on power cable.
10. Polarity Switch. The POLARITY switch selects the polarity of the output voltage at the rear panel connectors.
11. High Voltage Output. The high voltage output connector supplies high voltage to Scintillation Detectors. Use 10516A high voltage cable which has high voltage BNC connectors.
12. Stabilizer Input Only. The stabilizer input provides a connection for an external stabilization circuit.

WARNING

Dangerous voltage may exist on output jacks.

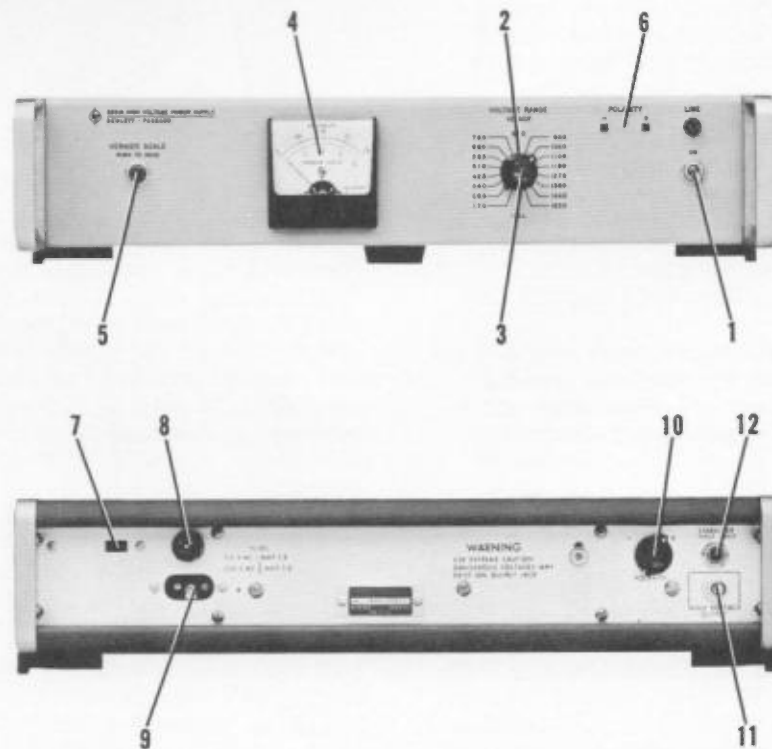

Model 5551A High Voltage Power Supply - Operation

The Model 5551A High Voltage Power Supply provides the high voltage (170V to 1614V at 1 ma) requirements of the photomultiplier tube in a scintillation detector. A VOLTAGE RANGE selector switch selects voltage output in 85 volt steps and a VERNIER control permits voltage adjustment between steps. The front panel

meter reads the output voltage of the power supply, or the vernier supply when the VERNIER SCALE pushbutton is pressed. The illustration below provides a step-by-step procedure for operation with Hewlett-Packard scintillation detectors (HP 10601A, 10602A, 10611A, 10612A, 10613A, or 10614A).

1. Connect high voltage BNC to BNC cable; one end to HIGH VOLTAGE OUTPUT connector and the other end to *hp* Scintillation Detector.
2. Set POLARITY to the positive polarity (+) position.

CAUTION: Use only high voltage BNC to BNC cable (*hp* 10516A) which has high voltage BNC connectors.

3. Set VOLTAGE RANGE to range within 85 volts (below) of desired voltage.
4. Turn AC power on.

Note: Front panel meter reads the power supply output voltage, or the vernier supply voltage when the front panel VERNIER SCALE pushbutton is depressed.

5. Push VERNIER SCALE pushbutton and adjust VERNIER control for a reading on the vernier meter scale equal to the difference between the desired voltage and the VOLTAGE RANGE setting. Release the pushbutton and the full value of the desired voltage will appear on the meter (fixed plus variable).

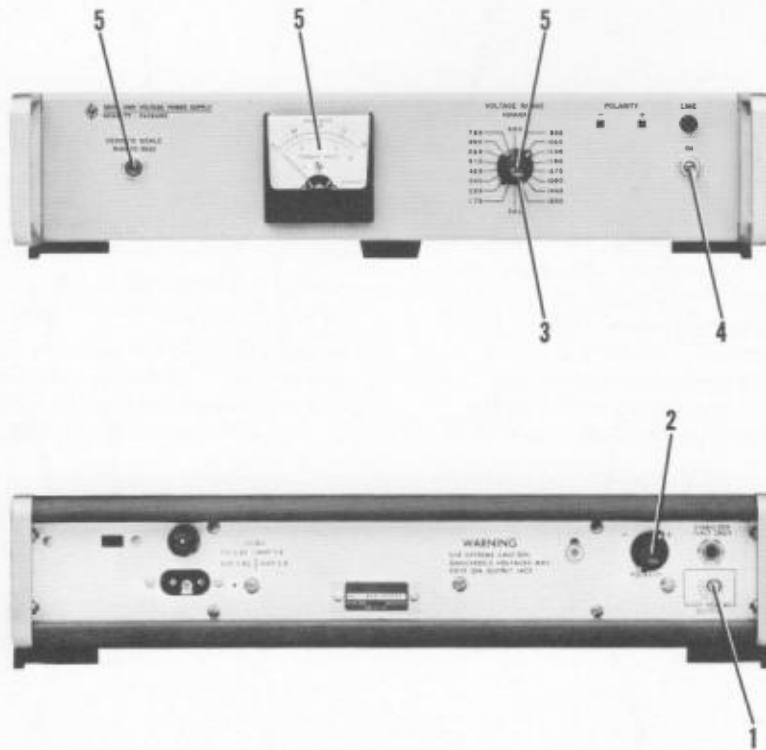

Model 10600A Scintillation Detectors - Terminals and Controls

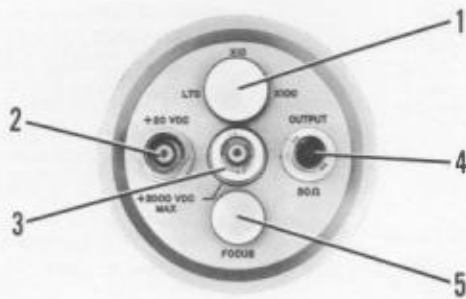

1. Gain Switch (LTC-X10-X100). Selects the three levels of gain. The long time constant position (LTC) is used when the detector is connected to an external linear amplifier, which is usually required for high counting rates requiring high resolution. With the short time constant positions, pulses are shaped to optimize the detector's resolution at high counting rates on both the X10 (gain 10) and X100 (gain 100) positions. To provide access to the gain switch, unscrew and remove the threaded plug.

2. +20 VDC Input Jack. The +20 VDC required for operation of the preamplifier section of the detector is connected to the +20 VDC "TNC" connector.
3. +2000 VDC MAX Input Jack. The available high voltage required for operation of the photomultiplier tube is connected to the +2000 VDC MAX high voltage BNC connector.

CAUTION

Use only high voltage BNC to BNC cable.

4. 50 Ω Output Jack. The 50 Ω output BNC connector provides positive output signals to drive the electronic scaler. Maximum unloaded outputs are: +4 volts for LTC position, +10 volts for X10 and X100 positions.
5. FOCUS. This control has been adjusted for optimum resolution at the factory. Should further adjustment be required, see adjustment procedure, Paragraph 4-9, in the Maintenance Section.

OPERATION

a. Set Gain switch to desired position (LTC-X10-X100). Unscrew and remove plug to gain access to switch.

b. Connect TNC to TNC cable from +20V TNC on Scintillation Detector to +20V TNC jack on rear panel of HP Scaler-Timers, or Scaler (5201L, 5202L, or 5203L).

c. Connect high voltage BNC to BNC cable from +2000 V DC MAX BNC jack on Scintilla-

tion Detector to output BNC jack on HP High Voltage Power Supply (5551A).

d. Connect BNC to BNC cable from OUTPUT BNC jack on Scintillation Detector to Signal Input BNC jack on Scaler-Timer (5201L, 5203L, or 5203L).

e. Turn on High Voltage Power Supply and Scaler-Timer or Scaler. Adjust High Voltage Power Supply for optimum value for a given sample and mode of operation.

HEWLETT-PACKARD SALES AND SERVICE OFFICES in the United States and Canada

ALABAMA

Huntsville, 35802
2003 Byrd Spring Rd. S.W.
(205) 881-4591
TWX: 510-579-2204

ALASKA

Bellevue, Wash. 98004
11656 N.E. 8th Street
(206) 454-3971
TWX: 910-443-2303

ARIZONA

Scottsdale, 85251
3009 No. Scottsdale Rd.
(602) 945-7601
TWX: 602-949-0111

Tucson, 85716
232 So. Tucson Blvd.
(602) 623-2564
TWX: 602-792-2759

CALIFORNIA

North Hollywood, 91604
3939 Lankershim Blvd.
(213) 877-1282 and 766-3811
TWX: 910-499-2170

Sacramento, 95821
2591 Carlsbad Ave.
(916) 482-1463
TWX: 916-444-8683

San Diego, 92106
1055 Shafter Street
(714) 223-8103
TWX: 714-276-4263

Palo Alto, 94303
1101 Embarcadero Rd.
(415) 327-6500
TWX: 910-373-1280

COLORADO

Englewood, 80110
7965 East Prentice
(303) 771-3455
TWX: 303-771-3056

CONNECTICUT

Middletown, 06458
589 Saybrook Rd.
(203) 346-6611
TWX: 710-428-2036

FLORIDA

Miami, 33125
2907 Northwest 7th St.
(305) 635-6461

Orlando, 32803
621 Commonwealth Ave.
(305) 425-5541
TWX: 305-275-1234

St. Petersburg, 33708
410-150th Ave., Madeira Beach
(813) 391-0211
TWX: 813-391-0666

GEORGIA

Atlanta, 30305
3110 Maple Drive, N.E.
(404) 233-1141
TWX: 810-751-3283

HAWAII

North Hollywood, Calif. 91604
3939 Lankershim Blvd.
(213) 877-1282 and 766-3811
TWX: 910-499-2170

ILLINOIS

Skokie, 60078
5500 Howard Street
(312) 677-0400
TWX: 910-223-3613

INDIANA

Indianapolis, 46205
3919 Meadows Dr.
(317) 546-4891
TWX: 317-635-4300

LOUISIANA

New Orleans
(504) 522-4359

MARYLAND

Baltimore, 21207
6660 Security Blvd.
(301) 944-5400

Rockville, 20852
12303 Twinbrook Pkwy.
(301) 427-7560
TWX: 710-828-9684

MASSACHUSETTS

Burlington, 01804
Middlesex Turnpike
(617) 272-9000
TWX: 710-332-0382

MICHIGAN

Southfield, 48076
24315 Northwestern Hwy.
(313) 353-9100
TWX: 313-357-4425

MINNESOTA

St. Paul, 55114
2459 University Ave.
(612) 646-7881
TWX: 910-563-3734

MISSOURI

Kansas City, 64131
7916 Paseo Street
(816) 444-9494
TWX: 816-556-2423

St. Louis, 63144
2814 South Brentwood Blvd.
(314) 647-4350
TWX: 314-962-3933

NEW JERSEY

Eatontown
(201) 542-0852

Englewood, 07631
391 Grand Avenue
(201) 567-3933

NEW MEXICO

Albuquerque, 87108
6501 Lomas Blvd., N.E.
(505) 255-5586
TWX: 910-989-1655

Las Cruces, 88001
114 S. Water Street
(505) 526-2486
TWX: 505-524-2671

NEW YORK

New York, 10021
236 East 75th Street
(212) 879-2023
TWX: 710-581-4376

Rochester, 14623
39 Saginaw Drive
(716) 473-9500
TWX: 510-253-5981

Poughkeepsie, 12601
82 Washington Street
(914) 454-7330
TWX: 914-452-7425

Syracuse, 13211
5858 East Molloy Rd.
(315) 454-2486
TWX: 710-541-0482

Endicott, 13764
1219 Campville Rd.
(607) 754-0050
TWX: 510-252-0890

NORTH CAROLINA

High Point, 27262
1923 N. Main Street
(919) 882-6873
TWX: 510-926-1516

OHIO

Cleveland, 44129
5579 Pearl Road
(216) 884-9209
TWX: 216-888-0715

Dayton, 45409
1250 W. Dorothy Lane
(513) 298-0351
TWX: 513-944-0090

OKLAHOMA

Oklahoma City
(405) 235-7062

PENNSYLVANIA

Camp Hill
(717) 737-6791

West Conshohocken, 19428
144 Elizabeth Street
(215) 248-1600 and 828-6200
TWX: 215-828-3847

Monroeville, 15146
2545 Moss Side Blvd.
(412) 271-5227
TWX: 710-797-3650

TEXAS

Dallas, 75209
P.O. Box 7166, 3605 Inwood Rd.
(214) 357-1881 and 332-6667
TWX: 910-861-4081

Houston, 77027
P.O. Box 22813, 4242 Richmond Ave
(713) 667-2407
TWX: 713-571-1353

UTAH

Salt Lake City, 84115
1482 Major St.
(801) 486-8166
TWX: 801-521-2604

VIRGINIA

Richmond, 23230
2112 Spencer Road
(703) 282-5451
TWX: 710-956-0157

WASHINGTON

Bellevue, 98004
11656 N. E. 8th St.
(206) 454-3971
TWX: 910-443-2303

GOVERNMENT CONTRACTING OFFICES

Middletown, Pa. 17057
Hewlett-Packard
Contract Marketing Division
Olmsted Plaza
(717) 944-7401
TWX: 717-760-4816

West Conshohocken, Pa. 19428
Hewlett-Packard
Contract Marketing Division
144 Elizabeth Street
(215) 753-1811
TWX: 215-820-3847

CANADA

Montreal, Quebec
Hewlett-Packard (Canada) Ltd.
8270 Mayrand Street
(514) 735-2273
TWX: 610-421-3484

Ottawa, Ontario
Hewlett-Packard (Canada) Ltd.
1762 Carling Avenue
(613) 722-4223
TWX: 610-492-1952

Toronto, Ontario
Hewlett-Packard (Canada) Ltd.
1415 Lawrence Avenue West
(416) 249-9196
TWX: 610-492-2382

Vancouver, B.C.
Hewlett-Packard (Canada) Ltd.
2184 W. Broadway
(604) 738-7520
TWX: 610-922-5059

HEWLETT - PACKARD INTERNATIONAL OFFICES

Electronic Instrument Sales and Service

ARGENTINA

Mauricio A. Saurez
Telecomunicaciones
Carlos Calvo 224, Buenos Aires
Tel: 30-6312

AUSTRALIA

Sample Electronics (Vic.) Pty. Ltd.
9-11 Cremorne Street
Richmond E. 1, Victoria
Tel: 42-4757 (3 lines)
Sample Electronics (N.S.W.) Pty. Ltd.
4 Grose Street, Glebe, N.S.W.
Tel: 69-6338 (6 lines)

AUSTRIA

UNILABOR H.m.b.H.
Wissenschaftliche Instrumente
Rummelhardtgasse 6/3
P.O. Box 33, Vienna IX/71
Tel: 42 61 81

BELGIUM

Hewlett-Packard Benelux
20-24 Rue de l'Hopital, Brussels 1
Tel: 11.22.20

BRAZIL

Ciental Importacao e Comercio Ltda.
R. Des Eliseu Guilhaume, 62
Sao Paulo 6
Tel: 32-4332

CHILE

Hector Calcagni
Casilla 13942, Santiago
Tel: 6.42.26

COLOMBIA

Instrumentacion Henrik A. Langebeck
& Cia. Ltda.
Apartado Aereo 6287
Bogota 1, D.E.
Tel: 45-78-06
Cable: AARIS - Bogota

DENMARK

Tage Olsen A/S
Ronnegade 1, Copenhagen 0
Tel: 29.48.00

FINLAND

INTO O/Y
P.O. Box 153
11 Meritullinkatu, Helsinki
Tel: 6.11.33

FRANCE

Hewlett-Packard France
150 Blvd. Massena, Paris 13e
Tel: 707.97.19

GERMANY

Hewlett-Packard VgmbH
Steindamm 35, Hamburg 1
Tel: 24.05.51

Hewlett-Packard VgmbH
Kurfurstenstrasse 95
Frankfurt a. Main
Tel: 52.00.36

Hewlett-Packard VgmbH
Reginfriedstrasse 13
Munich 9
Tel: 49.51.21/2

Hewlett-Packard VgmbH
Technisches Buro
Herrenbergerstrasse 110
703 Boblingen, Wurttemberg
Tel: 6971

Hewlett-Packard VgmbH
Lietzenburger Strasse 30
1000 Berlin 30
Tel: 24 92 71

IN EUROPE

Hewlett-Packard, S. A.
54 Route des Acacias
Geneva, Switzerland
Telephone: (022) 42.81.50
Telex: 2.24.86
Cable: HEWPACKSA

GREECE

K. Karayannis
Klaffmonos Square, Athens 124
Tel: 230.301

INDIA

The Scientific Instrument Company, Ltd.
6, Tej Bahadur Sapru Road, Allahabad 1
Tel: 2451

The Scientific Instrument Company, Ltd.
240, Dr. Dadabhai Naoroji Rd., Bombay 1
Tel: 26-2642

The Scientific Instrument Company, Ltd.
11, Esplanade East, Calcutta 1
Tel: 23-4129

The Scientific Instrument Company, Ltd.
30, Mount Road, Madras 2
Tel: 86339

The Scientific Instrument Company, Ltd.
B-7, Ajmeri Gate Extn., New Delhi 1
Tel: 271053

IRAN

Telecom Ltd.
P.O. Box 1812, Tehran
Tel: 43850

ISRAEL

Electronics & Engineering Ltd.
16 Kremenetski St., Tel Aviv
Tel: 35021-2-3

ITALY

Hewlett-Packard Italiana S.p.A.
Viale Lunigiana 46, Milan
Tel: 69.15.84/5/6

Hewlett-Packard Italiana S.p.A.
Palazzo Italia
Piazza Marconi, 25, Roma-Eur
Tel: 59.12.544/5

JAPAN

Yokogawa-Hewlett-Packard Ltd.
2270 Ishikawa-cho
Hachioji, Tokyo
Tel: Hachioji 0426-3-1231 (19 lines)

Yokogawa-Hewlett-Packard Ltd.
No. 3, 6-chome, Aoyama-Kitamachi
Akasaka, Minato-ku, Tokyo
Tel: 403-6511

Yokogawa-Hewlett-Packard Ltd.
No. 8, Umeda, Kita-ku, Osaka
Tel: 313-0091

Yokogawa-Hewlett-Packard Ltd.
No. 4, 3-chome, Himeikedori,
Chigusa-ku, Nagoya
Tel: 751-8545

KOREA

American Trading Company, Korea, Ltd.
112-35 Sokong-Dong, Jung-ku
Seoul P.O. Box 1103, Seoul
Tel: 3-7049, 3-7613

NETHERLANDS

Hewlett-Packard Benelux N.V.
23 Burg Roellstraat, Amsterdam W.
Tel: (020) 13.28.98 and 13.54.99

NEW ZEALAND

Sample Electronics (N. Z.) Ltd.
8 Matipo Street
Onehunga S. E. 5, Auckland
Tel: 565-361

NORWAY

Morgenstjerne & Co. A/S
Ingeniorfirma
6 Wessels Gate, Oslo
Tel: 20 16 35

PANAMA

Electronico Balboa, S.A.
P.O. Box 4929
Panama City 5, Panama
Tel: 3-0833

PERU

Fernando Ezeta B.
Casilla 3061
Lima
Tel: 78745

PORTUGAL

TELECTRA
Rua Rodrigo da Fonseca 103
P.O. Box 2531, Lisbon 1
Tel: 68 60 72 and 68 60 73 and 68 60 74

PUERTO RICO & VIRGIN ISLANDS

San Juan Electronics, Inc.
150 Ponce de Leon, Stop 3
P.O. Box 5167
Pta. de Tierra Sta., San Juan 00906
Tel: 725-3342, 724-4406

SPAIN

ATAIO, Ingenieros
Enrique Larreta 12, Madrid 6
Tel: 235.43.44 and 235.43.45

SOUTH AFRICA

F. H. Flanter & Co. (Pty.), Ltd.
Rosella House
Buitencingle Street, Cape Town
Tel: 3-3817

SWEDEN

H-P Instrument AB
Centralvagen 28, Solna, Centrum
Tel: 83.08.30

H-P Instrument AB
Idunagatan 28A
Goteborg
Tel: 27 68 00 and 27 68 01

SWITZERLAND

Max Paul Frey
Wankdorffeldstrasse 66, Berne
Tel: (031) 42.00.78

TAIWAN (FORMOSA)

Hwa Sheng Electronic Co., Ltd.
21 Nanking West Road, Taipei
Tel: 4 6076, 4 5936

TURKEY

TELEKOM Engineering Bureau
P.O. Box 376—Galata, Istanbul
Tel: 49.40.40

UNITED KINGDOM

Hewlett-Packard Ltd.
Dallas Rd., Bedford, England
Tel: Bedford 68052

VENEZUELA

Citec, C. A.
Edif. Arisan-Of #4
Avda. Francisco de Miranda-Chacaito
Apartado del Este 10.837, Caracas
Tel: 71.88.05

YUGOSLAVIA

Belram S.A.
83 Avenue des Mimosas
Brussels 15, Belgium
Tel: 35.29.58

For Sales and Service Assistance in Areas Not Listed Contact:

IN LATIN AMERICA

Hewlett-Packard Inter-Americas
1501 Page Mill Road
Palo Alto, California 94304, U.S.A.
Telephone: (415) 326-7000
TWX: 910-373-1267
Telex: 033811 Cable: HEWPACK

ELSEWHERE

Hewlett-Packard
Overseas Sales Department
1501 Page Mill Road
Palo Alto, California 94304, U.S.A.
Telephone: (415) 326-7000
TWX: 910-373-1267
Telex: 033811 Cable: HEWPACK

FREQUENCY AND TIME DIVISION, PALO ALTO, CALIFORNIA

HEWLETT  PACKARD

PRINTED IN U.S.A.