



SWEPT FREQUENCY TECHNIQUES

APPLICATION NOTE 65



ATTENUATION



IMPEDANCE
REFLECTION
COEFFICIENT



POWER

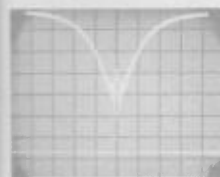

FREQUENCY

CERTIFICATION

The Hewlett-Packard Company certifies that this instrument was thoroughly tested and inspected and found to meet its published specifications when it was shipped from the factory. The Hewlett-Packard Company further certifies that its calibration measurements are traceable to the U.S. National Bureau of Standards to the extent allowed by the Bureau's calibration facility.

WARRANTY AND ASSISTANCE

All Hewlett-Packard products are warranted against defects in materials and workmanship. This warranty applies for one year from the date of delivery, or, in the case of certain major components listed in the operating manual, for the specified period. We will repair or replace products which prove to be defective during the warranty period. No other warranty is expressed or implied. We are not liable for consequential damages.

For any assistance contact your nearest Hewlett-Packard Sales and Service Office. Addresses are provided at the back of this manual.



APPLICATION NOTE 65

SWEPT FREQUENCY
TECHNIQUES

HEWLETT-PACKARD COMPANY
1501 Page Mill Road, Palo Alto, California, U.S.A.
Cable "HEWPACK" Telephone (415) 326-7000

WJG

Printed: AUG 1965



ATTENUATION



IMPEDANCE
REFLECTION
COEFFICIENT



POWER



FREQUENCY

TABLE OF CONTENTS

	Page
INTRODUCTION	1
History	1
Basic Concepts	2
Leveled Systems	6
ATTENUATION.	15
General.	15
Measurements in Waveguide.	15
Waveguide System Accuracy.	19
Directivity Measurement	20
Measurements in Coax	22
Coaxial System Accuracy	22
IMPEDANCE.	23
General.	23
Measurements in Waveguide	23
X-Y Recording Reflection Tests	26
RF Pre-Insertion - X-Y Recorder Technique	26
Waveguide System Accuracy.	27
Measurements in Coax - 500 Mc to 8 Gc	28
Coaxial System Accuracy	28
Measurements in Coax - 8.2 to 12.4 Gc	29
Special Techniques	29
POWER	31
General.	31
Thermistor Mount Efficiency Testing	31
TWT Amplifier Gain Test	33
High Resolution Attenuation Tests	33
FREQUENCY	37
General.	37
Wavemeter Calibration.	37
System Accuracy	39
Cavity Q Measurements	40
NOISE FIGURE	41

INTRODUCTION

The scope of microwave measurements now possible with swept-frequency techniques is an important consideration to the engineer and scientist. No matter which parameter he chooses to measure, there is a good chance swept methods can be applied for quickly obtaining accurate and complete data.

Knowing which applications are best served with swept techniques and implementing appropriate systems is a continuous challenge, since equipment and methods are constantly being improved. This Application Note describes recently developed systems and techniques that accomplish two major objectives:

1. Provide continuous broadband displays of microwave performance, enabling dynamic adjustments to test devices and speeding measurements, and
2. Eliminate or reduce errors in swept frequency measurements so that "double checking" with spot-frequency methods is unnecessary.

HISTORY

Since the introduction of the first broadband, high directivity directional coupler by Hewlett Packard¹ there has been a continuous effort toward developing more efficient measuring systems using swept techniques. High directivity couplers were first used in fixed-frequency reflectometer systems² where the forward and reverse signal levels were detected and noted on separate meters. The ratio of the two meter readings was then calculated to determine reflection coefficient (ρ) of devices in test. Then, in 1954, the hp model 670 Sweep Oscillator introduced a new dimension to microwave testing³. This instrument produced a swept RF signal through the use of a motor-driven, mechanically-tuned klystron. Another new instrument, the hp 416A Ratio Meter, automatically indicated the heretofore calculated ratio of forward to reverse signal level so complete broadband tests could be made in less than 30 seconds. HP Application Notes⁴ described complete swept frequency systems for broadband reflection and attenuation tests using the newly developed instruments.

By 1957 the mechanically-tuned klystron gave way to the electronically-tuned Backward Wave Oscillator tube incorporated in the hp 680 Sweep Oscillator. The 680 lifted various source encumbrances such as klystron mode-switching and tracking, long sweep times, and the wear involved with mechanical tuning. Improved test methods such as the calibration grid-X-Y recorder techniques⁵ helped overcome the combined effects of scalar errors produced by directional couplers, detectors, and ratio meter. As better methods were introduced, swept-frequency testing continued to assume importance as it replaced less efficient fixed-frequency reflection, gain, and attenuation tests.

Further development work at HP led to a completely new design of sweep oscillator; the 690A/B series. Introduced in 1963⁶, these newly designed "sweepers" were greatly enhanced by the experience gained over many years of swept-frequency testing in HP production lines. One of the most important new features of the 690 was its ability to level output power at any point in the RF circuit through the use of a feedback system and PIN diode attenuator. With forward power held constant as a function of frequency and/or load impedance variation, readout of only one signal level was required for transmission and reflection tests. Thus, a ratio meter was no longer required and faster



ATTENUATION

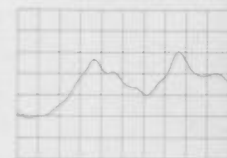

IMPEDANCE
REFLECTION
COEFFICIENT



POWER



FREQUENCY

¹ HP Journal, Vol. 3, No. 7-8, March 1952
² HP Journal, Vol. 4, No. 5-6, January 1953
³ HP Journal, Vol. 6, No. 1-2, Sept. - Oct. 1954
⁴ HP Application Note 42
⁵ HP Application Note 54
⁶ HP Journal, Vol. 15, No. 4, December 1963

sweeps could be employed with convenient oscilloscope readout. To complement this new sweeper, crystal detectors of exceptionally flat frequency response and close square-law adherence were developed by HP for broadband detection.

More recent additions to the total swept frequency system concept pioneered by HP include the 1416A Swept Frequency Indicator plug-in for the hp 140A Oscilloscope. This unit is designed specifically to meet the readout needs of leveled swept-frequency systems. The newer 690C/D sweep oscillators shown in this Note are refinements of the 690A/B series. Operation of both series of instruments is the same however, so either may be used in the applications that follow.

The applications and equipment shown in this Note are representative of HP's continuous effort to develop not only individual parts, but complete measurement systems from source to readout for best total performance.

BASIC CONCEPTS

Several basic concepts are common to all swept measurements shown in this Note. A discussion of these concepts may suggest methods in which systems can be varied to suit other applications. In each system, three basic functions are performed:

1. Signal generation
2. Detection
3. Readout

Signal Generation. Producing a swept RF signal is just one of many requirements placed on the source in modern swept-frequency systems. Improved accuracy and convenience depends largely on a number of important contributions made by the hp 690C/D sweep oscillators. Major improvements over other sources include:

- a. Ability to level power in the external circuit for achieving good source match.
- b. Accurate sweep and marker frequency calibration with linear sweeps in both leveled and unleveled operation.
- c. Clean RF signals that are low in spurious and residual output.
- d. Straightforward control functions that simplify overall system calibration.
- e. Frequency and amplitude stability when various conditions are changed such as sweep width and rate, line voltage, load impedance, or output power.

The hp 690C/D generates swept RF signals in 1.5:1 and 2:1 frequency bands from 500 Mc to 40 Gc using a backward wave oscillator (BWO) and its associated circuits. The 690D series, available in bands from 1 Gc to 12.4 Gc, contain PIN diode attenuators for amplitude modulating and/or leveling the RF output. The PIN line absorbs RF power out of the BWO proportional to an applied DC bias voltage or modulating signal. Since the BWO grid-cathode voltage is not varied for modulation or leveling, excellent amplitude and frequency stability is achieved with freedom from incidental FM.

The 690C series of grid-cathode modulated sweepers cover the entire 500 Mc - 40 Gc spectrum and are used in the bands above 12.4 Gc where PIN lines are not available or in lower bands where modulation requirements are less demanding. All other functions operate the same as the D series.

All 690C/D sweepers contain an automatic leveling circuit (ALC) consisting of a DC amplifier whose output is connected to the PIN line or BWO grid-cathode circuit. The ALC input is a DC feedback voltage derived from either a crystal detector or a power meter monitoring the RF level at some point in the measurement system. In a basic leveling system, as shown in Figure 1, the feedback loop is arranged so forward power is held constant with frequency and load impedance variation. The leveling amplifier has a differential input with an adjustable reference voltage that sets the operating power level. Increasing this voltage calls for more detector voltage, hence more RF output to satisfy the leveler amplifier. The overall loop gain of the ALC system is adjusted



START/STOP sweep limits indicated by large slide rule dial for broad-band tests.



DIGITAL MARKERS identify frequencies and bands of special interest.

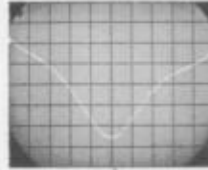

MARKER SWEEP selects sweep limits set up by markers for magnified frequency displays.

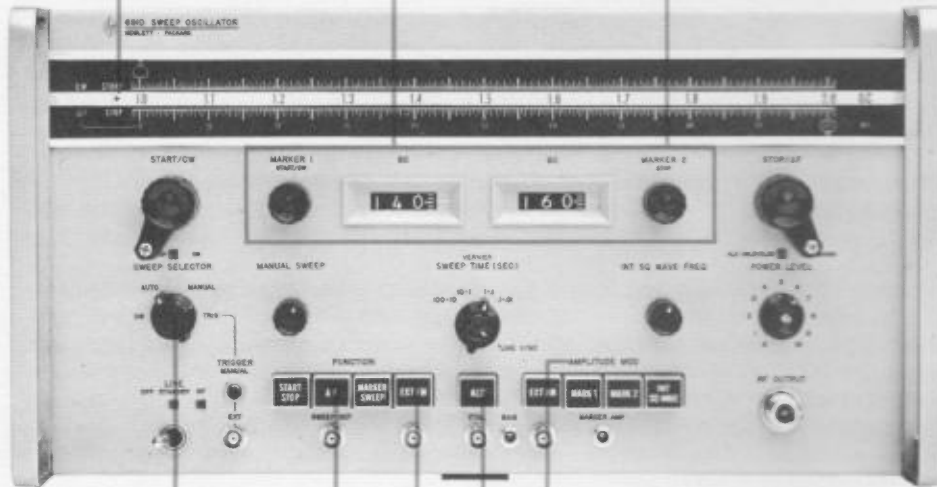

PIN ATTENUATOR in 690D series for modulating and/or leveling without incidental FM or frequency shift.

AUTOMATIC LEVELING CIRCUIT for constant output power independent of frequency or load impedance.

EXT FM for remote frequency programming and special FM tests.

ΔF for calibrated narrow band symmetrical sweeps for FM tests.

VERSATILE SWEEP MODES for automatic, manual, or triggered operation.

4000-A-27

Figure 2. Flexibility and accuracy of hp 690-series sweep oscillators increases their usefulness for all swept applications. Oscilloscope displays illustrate simplicity of system readout when hp sweeper and auxiliary equipment is used.

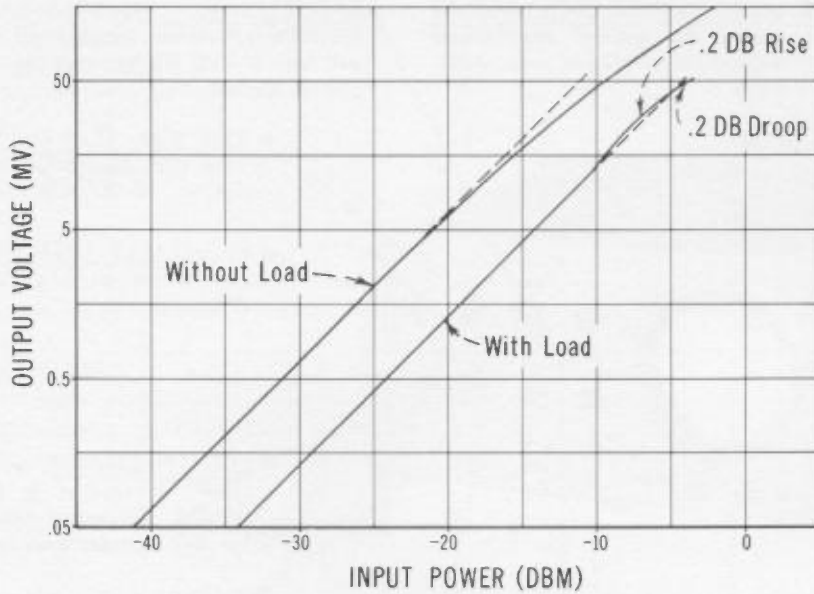

Figure 3. Square-law response of typical Model 423A or 424A Detector with and without matched square-law load resistor (option 02).

remain important considerations for the ALC detector. Figure 3 shows the square-law characteristics and sensitivity of 423A and 424A detectors for loaded and unloaded conditions.

Where knowledge of absolute power level is required, the hp 431B power meter and 478A coax or 486A waveguide series of temperature compensated thermistor mounts are used for ALC or readout detection. Longer sweep time is required with power meter detection so an X-Y recorder readout is used instead of an oscilloscope. A dc current proportional to the 431B meter deflection (RECORDER OUTPUT) is used for ALC or recording purposes. The thermistor mounts are inherently good square-law detectors, have good broadband impedance characteristics and are compensated to reduce thermal drift by a factor of 100:1 over uncompensated types.

Readout. One of the most important advantages made possible by source and detector improvements is the continuous display of data on an oscilloscope. Because sweeper power is leveled, a ratiometer is not necessary for reflection and attenuation tests. By eliminating the ratiometer, with its narrow band audio amplifier, faster sweeps without AM are possible (when crystal leveling). Now a dc voltage out of the detector, proportional to RF level, can be displayed on an oscilloscope as a function of frequency. The rapid sweeps eliminate flicker yet the detector response time is fast enough to faithfully reveal even sharp discontinuities or attenuation changes in test devices.

The hp 140A Oscilloscope with 1416A Swept Frequency Indicator plug-in shown in Figure 4, is designed specifically for leveled swept frequency measurements, providing direct readout in db/cm through the use of a logarithmic vertical amplifier. The log amplifier provides calibrated sensitivities from 10 db/cm to 0.5 db/cm for high resolution of attenuation or return loss (ρ). The log amplifier is designed to operate directly from square-law loaded 423A or 424A crystal detectors over their 30 db square-law range from 50 mv down to low level. Features such as the retrace blanking input and adjustable amplifier bandwidth speed measurements and minimize readout error. For added versatility, the vertical input may be switched from logarithmic operation to linear, providing calibrated vertical sensitivities from 10 mv/cm to 50 μ v/cm when db readout is not desired.

Provision is made on the 1416A for fast calibration and operation with an X-Y recorder if desired. A dc calibrating voltage out of the 1416A provides 0, -10, -20 and -30 db reference levels for calibrating the X-Y recorder vertical span to linear graph paper.



ATTENUATION



IMPEDANCE REFLECTION COEFFICIENT



POWER

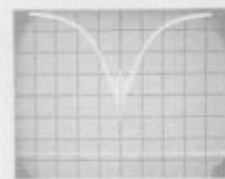

FREQUENCY

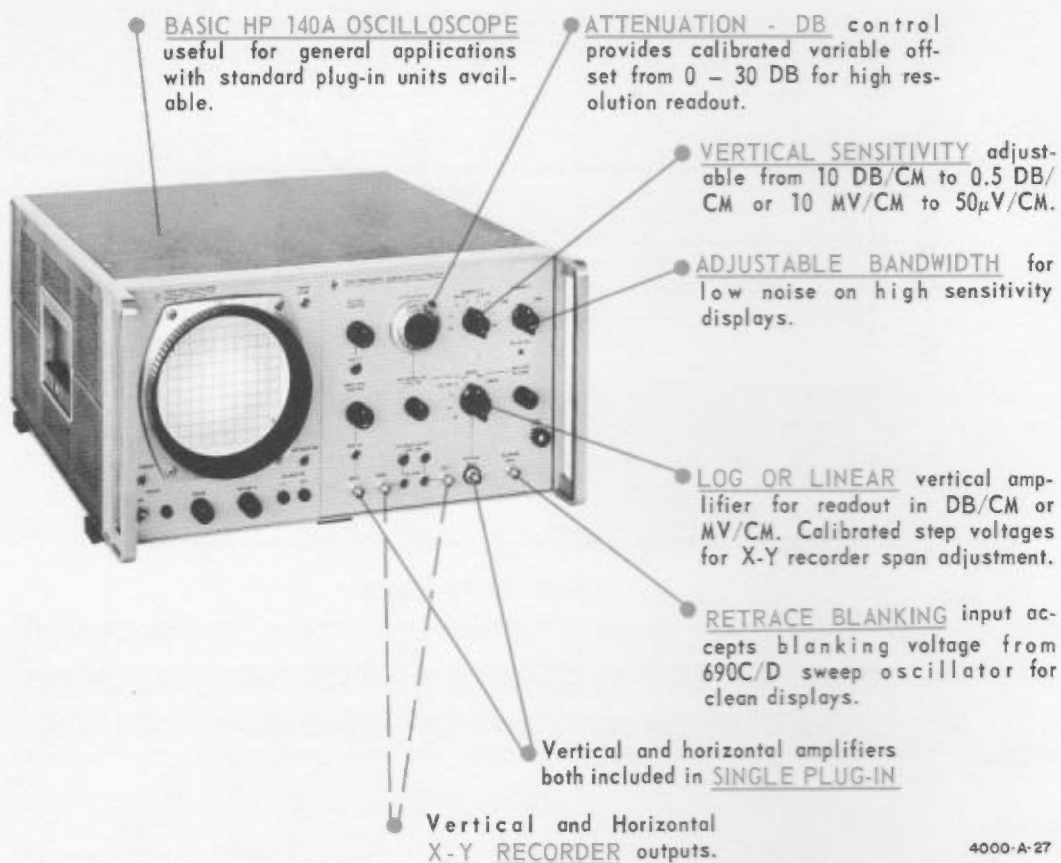

Figure 4. HP 140A Oscilloscope with 1416A Swept-Frequency Indicator simplifies swept attenuation and reflection tests - providing 30 db dynamic range and high resolution (up to 0.5 db/cm).

With leveled source power and good square-law response in the readout detector, direct correlation exists between the calibrating voltage and actual test voltages thus eliminating the need for plotting a calibration grid on the recorder. Readout is thus directly in db/division on the graph paper over a 30 db dynamic range. The 1416A horizontal amplifier accepts the dc sweep voltage from the 690C/D and has variable gain for setting overall display width.

Direct readout on conventional high gain dc oscilloscopes is also possible over a 10 db dynamic range using the transparent CRT scales supplied with this Note. Total attenuation (or return loss) range may be increased from 10 db to about 24 db with the oscilloscope's calibrated vertical sensitivity control. The hp 140A Oscilloscope with 1400A and 1420A plug-in units, or the hp 130C Oscilloscope are suitable alternates to the 140A/1416A that provide 20 to 24 db total range. Note there are two sets of SWR and attenuation scales printed on the transparent foil. One set is for direct viewing of standard oscilloscope displays. The other set is calibrated for photographing oscilloscope displays on internal graticule CRT's. Instructions for using the scales are included in the attenuation and impedance applications described later.

X-Y recording using an RF pre-insertion technique and tuned audio amplifier is required in a few applications where signal levels are very low. This technique is described in the Attenuation Section for measuring directional coupler directivities over 40 db.

LEVELED SYSTEMS

Crystal Leveling in Coax and Waveguide. With the basic operation of the leveling loop of Figure 1 now in mind, we can turn to specific leveling configurations. Figure 5 shows the equipment set-up for obtaining leveled swept frequency signals in coax from 500 Mc

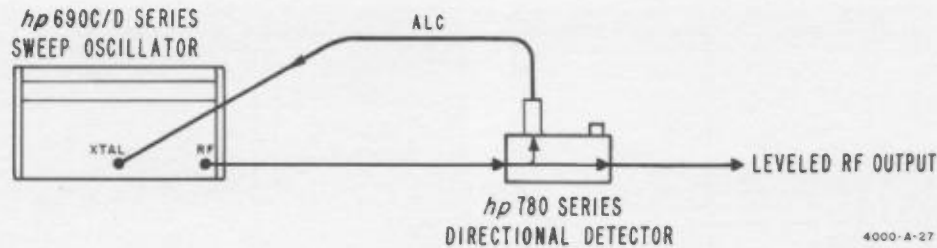

ATTENUATION



IMPEDANCE REFLECTION COEFFICIENT



POWER

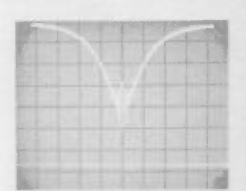

FREQUENCY

INSTRUMENT	FREQUENCY - GC				
	0.5 - 1.0	1 - 2	2 - 4	4 - 8	8 - 12.4
Sweep Oscillator	H10-691C	691C/D	692C/D	693C/D	694C/D
Directional Detector	Narda 3041-10 with hp 423A Crystal Detector	786D	787D	788C	789C
Leveled Power Available - mw \geq	40	100/70	70/40	30/15	40/25
Leveled Power Variation* (db)	$\pm 0.5/0.4$	$\pm 0.4/0.3$	$\pm 0.4/0.3$	$\pm 0.5/0.4$	$\pm 0.7/0.6$

* Maximum variation includes directional detector frequency response, ALC amplifier and measurement ambiguity. Typical variation is considerably less.

Figure 5. System for obtaining crystal leveled sweep oscillator output in coaxial (type N) transmission line, 500 Mc to 12.4 Gc. All systems from 1 to 12.4 Gc use hp 780 series directional detectors comprising a directional coupler and crystal detector matched for flat frequency response.

to 12.4 Gc. The ALC feedback voltage is derived from the hp 780-series directional detector in all but the lowest frequency band. The directional detector consists of a directional coupler with a crystal detector mounted directly on the secondary arm. While a separate directional coupler and crystal detector may be used, tighter correlation between output power and detector voltage is achieved by combining the two in a single integrated unit.⁷ The equipment required for each band, along with the maximum leveled power available and leveling variation, is shown in the table of Figure 5.

Coaxial reflectometers described later in the Impedance Section of this Note utilize a dual directional coupler and two separate detectors instead of a directional detector. In this case, the frequency response characteristics of the coupler's forward arm is essentially the same as the reverse arm and the net variation in the readout is small. See "Measurements in Coax - 500 Mc to 8 Gc" in the IMPEDANCE Section.

Figure 6 shows a super-leveled waveguide system for obtaining constant power from 2.6 to 40 Gc. As in the coax system of Figure 5, crystal detection is used to derive the ALC feedback voltage. In this system a 3 db directional coupler and secondary arm termination are placed between the 10 db directional coupler and ALC detector. The inverse coupling characteristics of the 3 db coupler main arm compensates for coupling variations of the 10 db coupler auxiliary arm. The net result is cancellation of coupling variations that would otherwise affect the leveling loop and output power.

⁷ HP Journal Vol. 16, No. 6, February 1965

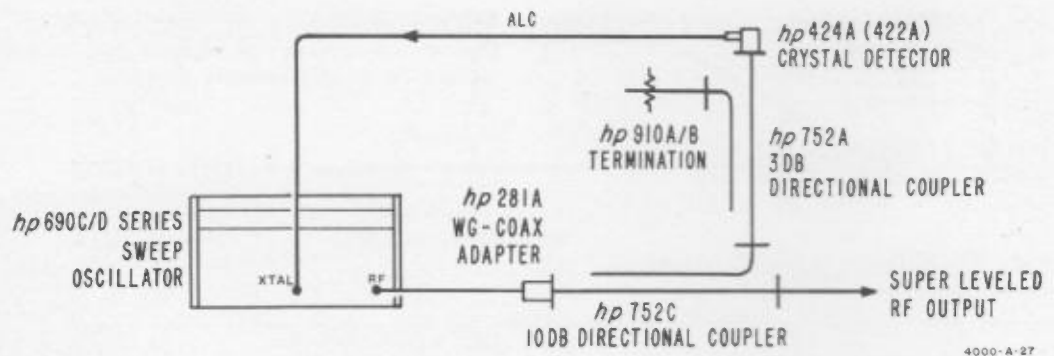

INSTRUMENT	BAND (FREQUENCY - GC)									
	S	G	J	H	X	M	P	K	R	
Sweep Oscillator	692C/D	693C/D		693C/D	694C/D	694C/D	H09-695C	699C	696C	697C
Waveguide-to-Coax Adapter	S281A	G281A	J281A	H281A	---	none required				
10-db Directional Coupler	S752C	G752C	J752C	H752C	X781A*	M752C	P752C	K752C	R752C	
3-db Directional Coupler	S752A	G752A	J752A	H752A	---	M752A	P752A	K752A	R752A	
Waveguide Termination	S910A	G910A	J910A	H910A	---	M914A	P910A	K914B	R914B	
Crystal Detector	S424A	G424A	J424A	H424A	---	M424A	P424A	K422A	R422A	
Leveled Power Available - mw \geq	70/40	30/15		30/15	40/25	40/25	10	40	10	5
Leveled Power** Variation (db - approx)	$\pm 0.7/0.6$	$\pm 0.7/0.6$	$\pm 0.7/0.6$	$\pm 0.7/0.6$	$\pm 0.7/0.6$	± 1.1	± 1.1	± 2.75	± 2.8	

* HP X781A Directional Detector eliminates need for separate components in leveling loop.

** Includes effects of coupling variation, detector response, detector/coupler mismatch and ALC amplifier. Typical variation is less than indicated because errors do not add arithmetically. Complete leveled systems may be special-ordered from Hewlett-Packard to meet specific leveling requirements.

Figure 6. Super-leveled sweep oscillator systems for waveguide, 2.6 to 40 Gc using crystal ALC detector. Two coupler arrangement shown results in mutual compensation of coupling variation with frequency improving leveled performance.

Note from the equipment table, an hp model X781A directional detector is available which replaces all leveling components of Figure 6 external to the sweep oscillator. The coupling mechanism of the X781A consists of a 10 db directional coupler with a 3 db directional coupler and load compensating the auxiliary arm in a compact configuration. The crystal detector is an integral part of the X781A, providing an overall frequency response of ± 0.5 db or better. The waveguide reflectometers described later do not use the super-leveled setup because forward and reverse coupler characteristics are nearly the same. This results in mutual compensation and flat response in the readout display. The leveling adjustment procedure however, is the same for both the super-leveled source, and the leveled reflectometer.

Crystal Leveling Instructions. Because the ALC system utilizes a feedback amplifier, the circuit must be properly adjusted to the leveling components for maximum gain without oscillations in the feedback loop. If loop gain is too low, the leveling circuit will be ineffective as shown by the power variations in Figure 7(a).

If loop gain is too high, the system will become unstable and oscillations such as shown in Figure 7(b) will occur. Improper operation of the ALC loop can be readily observed in measuring systems using oscilloscope readout.

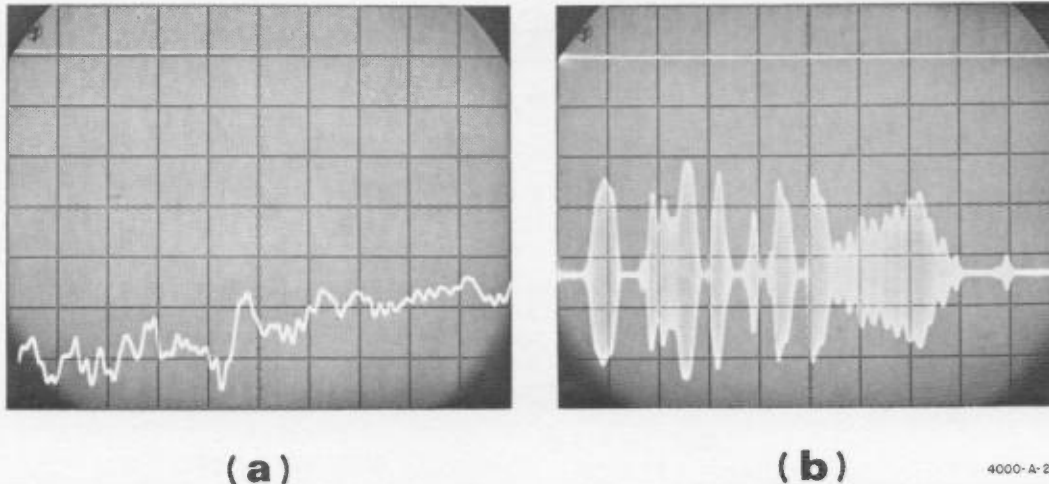

Figure 7. Oscilloscope patterns for (a) insufficient ALC gain - power output unlevelled (b) excessive ALC gain for power level setting; oscillations occur in ALC feedback loop.

When other types of readout are being used, (e. g. X-Y Recorder) connect an oscilloscope to the 690C/D rear panel jack marked POWER METER. Connect the oscilloscope horizontal input to the SWEEP output on the 690C/D front panel. Proceed as follows:

1. Set up controls for an automatic rapid sweep over the desired band with LINE switch in STANDBY.
2. Set ALC POWER LEVELING INPUTS switch to CRYSTAL, and depress ALC button.
3. Set POWER LEVEL to 5 and coarse power level (screwdriver adjust) fully counter-clockwise. Set ALC "GAIN" fully clockwise.
4. Set LINE to RF and slowly increase the coarse POWER LEVEL control for an output power indication on the oscilloscope across the full operating band. Backoff ALC "GAIN" until oscillations in the feedback loop just cease as observed on the oscilloscope.
5. Continue increasing coarse POWER LEVEL control until leveling light on the front panel of the sweeper begins to flash or the desired power level is reached, as monitored in the RF output circuit. Reduce GAIN as necessary if oscillations should result.
6. Backoff the power level control until the leveling light just glows steadily. The sweeper is now operating at optimum feedback gain and maximum levelled power out.

Once a system has been adjusted, readjustment of the gain control is normally not required unless different couplers or detectors are substituted in the leveling loop. The calibrated power level control may be simply adjusted each time the system is turned on for proper leveling as indicated by the front panel leveling indicator.

Power Meter Leveling: The design of the hp 431B temperature compensated power meter and associated thermistor mounts provides the required stability and metering configuration for a recorder output current proportional to meter deflection. This current (0-1 ma dc into 1 K ohm) is suitable for either recording purposes or driving the ALC circuit in any hp 690-series sweeper for leveling power output.

In addition to a constant output across the band, power meter leveling provides a continuous indication of the absolute power output which is useful in setting up specific test conditions. Because of excellent zero carryover*, the 431B range switch and zero controls make effective variable attenuators since they control the ALC loop in a precisely

* Zero carryover is the ability of the power meter to remain zeroed when switching from range-to-range after making an initial adjustment on the most sensitive range to be used. The 431B maintains 0.5% zero carryover.



ATTENUATION



IMPEDANCE
REFLECTION
COEFFICIENT



POWER



FREQUENCY

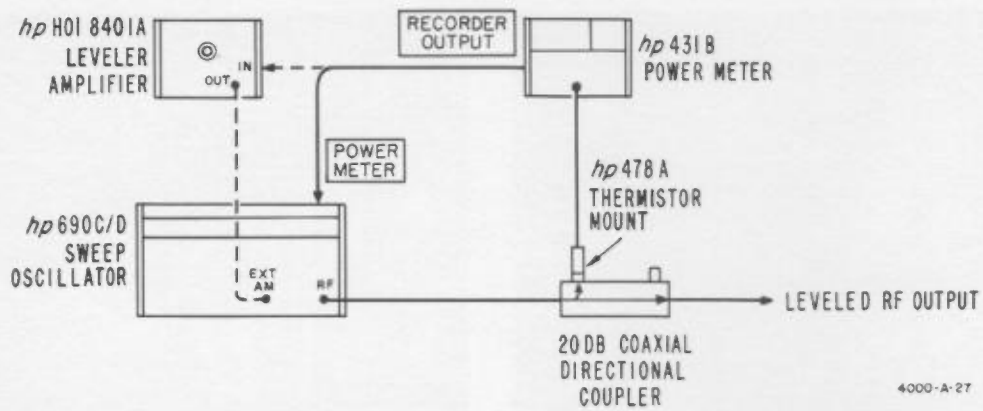

4000-A-27

INSTRUMENT	FREQUENCY - GC			
	0.5 - 1.0	1 - 2	2 - 4	4 - 8
Sweep Oscillator	H10-691C	691C/D	692C/D	693C/D
Directional Coupler	Narda 3041-10	796D	797D	798C
Thermistor Mount	← 478A →			
Power Meter	← 431B →			
Leveler Amplifier (optional)	← H01-8401A →			
Leveled Power Available - mw \geq	40	100/70	70/40	30/15
Leveled Power Variation (db - approx)*	$\pm 0.5/0.4$	$\pm 0.5/0.4$	$\pm 0.52/0.42$	$\pm 0.62/0.52$
* Maximum variation includes coupling variations, thermistor/coupler mismatch, ALC amplifier and measurement ambiguity. Typical variation is considerably less.				

Figure 8. General system for power meter leveling sweep oscillators in coax - 500 Mc to 8.0 Gc.

known manner. This feature can be used to accurately control output power from the sweeper or calibrate an X-Y recorder in db or power.

The dc substitution feature on the 431B allows very accurate dc power level changes to be made in the thermistor using an external supply. When the 431B is used in the ALC loop, a precise dc power change in the thermistor causes a precise RF output change from the sweeper. This capability is described in the Power section of this Note under "High Resolution Attenuation Tests". Examples of other useful applications for power meter leveling are also shown in the Power section.

Two basic systems for power meter leveling are shown in Figures 8 and 9. For leveled power in waveguide use the systems shown in Figure 9. The power available for each band plus the approximate power variations that can be expected are also shown in the tables. In critical applications, fine grain power variations may be further reduced with additional ALC feedback amplifier gain. The hp H01-8401A Leveler Amplifier may be added to the basic leveling setups of Figures 8 and 9 for this purpose. When the H01-8401A is used, the 431B recorder output is connected to the amplifier input as shown by the dashed lines. The amplifier output connects to the 690C/D external AM input.

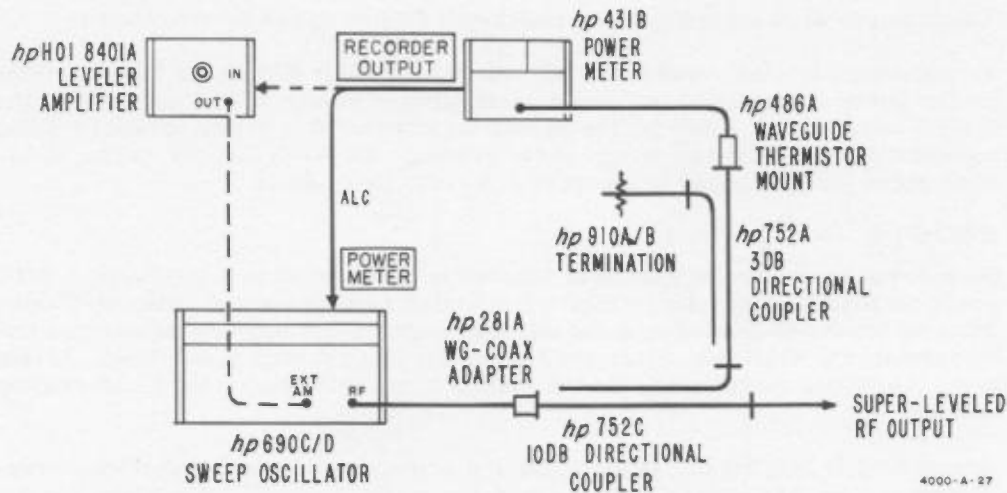

4000-A-27

INSTRUMENT	BAND (FREQUENCY - GC)									
	S	G	J	H	X	M	P	K	R	
	2.6 - 3.95	3.95 - 5.85	5.3 - 8.2	7.05 - 10	8.2 - 12.4	10 - 15	12.4 - 18	18 - 26.5	26.5 - 40	
Sweep Oscillator	692C/D	693C/D		693C/D	694C/D	694C/D	H09-696C	695C	696C	697C
Waveguide-to-Coax Adapter	S281A	G281A	J281A	H281A	X281A	none required				
10-dB Directional Coupler	S752C	G752C	J752C	H752C	X752C	M752C	P752C	K752C	R752C	
3-dB Directional Coupler	S752A	G752A	J752A	H752A	X752A	M752A	P752A	K752A	R752A	
Waveguide Termination	S910A	G910A	J910A	H910A	X910B	M914A	P910A	K914B	R914B	
Thermistor Mount	S486A	G486A	J486A	H486A	X486A	M486A	P486A	K486A	R486A	
Power Meter	431B									
Leveler Amplifier (optional)	H01-8401A									
Leveled Power Available - mw \geq	70/40	30/15	30/15	40/25	40/25	10	40	10	5	
Leveled Power Variation* (db - approx)	$\pm 0.5/0.4$	$\pm 0.56/0.46$	$\pm 0.56/0.46$	$\pm 0.56/0.46$	$\pm 0.56/0.46$	± 0.56	± 0.56	± 0.8	± 0.8	

* Includes effects of coupling variation, thermistor/coupler mismatch and ALC amplifier. Typical variation is less because errors do not add arithmetically.

Figure 9. Super leveled sweep oscillator in waveguide using power meter leveling.

Thermistors inherently have long thermal time constants, slowing their response to sudden power variations. This factor must be considered when power meter leveling a sweep oscillator. The amplifier-feedback arrangement used in the hp 431B power meter reduces thermal response time in the 478A and 486A thermistor mounts to about 0.1 second so that exceedingly long sweep times are not required. The bandwidth of this feedback circuit however, is narrow compared to crystal leveling so sweep time must be longer. If the sweep is too rapid, the leveling loop will not have time to respond to fine grain variations in output power, and the leveling will be ineffective. A good rule of thumb when power meter leveling the hp 690 sweepers with the 431B is 20-30 seconds for a full band sweep. This time is compatible with an X-Y recorder time constant.

Power Meter Leveling Instructions: With the equipment set up for power meter leveling, preset the 690C/D controls as directed in step 1 and make adjustments that follow:

1. With the LINE in STANDBY, set desired sweep limits and select the MANUAL SWEEP mode. Set ALC POWER LEVELING INPUTS switch on rear panel to POWER METER. Depress ALC button.



ATTENUATION

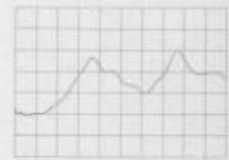

IMPEDANCE REFLECTION COEFFICIENT



POWER



FREQUENCY

2. Null and zero 431B according to the instrument Operating and Service Manual.
3. For maximum leveled power out of the system, set 431B RANGE as follows: Note leveled power rating listed in the equipment table of Figure 8 or 9 for the specific system being set up. Allow for the attenuation introduced by the directional coupler and calculate the equivalent power meter reading. Set 431B RANGE so the calculated power level will read in the upper 2/3 of the meter scale.

EXAMPLE:

Suppose the super-leveled system of Figure 9 is being set up in S-Band using a 692D sweep oscillator. The table in Figure 9 indicates a leveled power rating of 40 mw. Allowing for the 13 db total coupling attenuation introduced between the sweeper and thermistor, the 431B should indicate 2 mw at the rated system power level. In this case, the proper range setting for the 431B is 3 mw which places the 2 mw reading upscale.

4. Preset 690C/D POWER LEVEL to "5" and the center screwdriver adjust fully counterclockwise. Set ALC "GAIN" fully clockwise.
5. Turn 690C/D LINE to RF and slowly increase the screwdriver POWER LEVEL control until the 431B indicates power reading calculated in step 3. The leveling indicator lamp on the 690C/D should glow steadily.
6. Ordinarily, oscillations in the ALC circuit will not occur with power meter leveling unless the H01-8401A Leveler Amplifier is used. To verify freedom from oscillations, connect an oscilloscope to the crystal input jack of the 690C/D. If oscillations are present, slowly turn ALC "GAIN" counterclockwise until oscillations on oscilloscope just disappear.
7. Increase POWER LEVEL control until the reference power reading on the 431B is restored. Check and readjust ALC "GAIN" and/or POWER LEVEL to obtain maximum leveled power without oscillation as the MANUAL SWEEP is rotated throughout its entire range. In most cases, the maximum leveled power will be greater than the values given in the table and the power meter may have to be up-ranged to maintain an on-scale reading. The 690C/D is now operating at maximum leveled power. If something less than maximum power is desired, simply calculate the equivalent power meter reading and make all GAIN and POWER LEVEL adjustments to the new value.

If the leveled power is to be varied in precise 5 db steps by changing the 431B range switch, optimum leveling conditions must be set up on the most sensitive power meter range to be used. This is because the ALC loop gain is maximum on the most sensitive range setting and oscillations can occur in the feedback loop. The practical range of power meter switching (after a leveled power has been set up) is about 20 db, limited at the high power end by the maximum leveled power available from the sweep oscillator and limited on the low end by excessive loop gain in the ALC circuit.

Power Meter Leveling With the H01-8401A Leveler Amplifier: In applications where maximum leveling flatness is required using power meter leveling, connect the recorder output jack of the 431B power meter to the input of the hp H01-8401A Leveler Amplifier as shown by the dashed lines in Figure 8 and 9. Connect the amplifier output to the sweeper EXTERNAL AM input and depress the EXTERNAL AM button. Release the ALC button on the sweeper front panel since the leveling amplifier in the sweep oscillator is not used in this configuration. Turn 690C/D POWER LEVEL coarse adjust fully clockwise. Determine the proper range switch setting for the 431B power meter as described in the previous discussion on power meter leveling. Adjust the H01-8401A GAIN and POWER LEVEL for maximum gain, without oscillation, at the desired power level as described previously. Leveling performance with the H01-8401A may be expected to be about ± 0.1 db better than power meter leveling without the amplifier. This improvement may be significant in certain high resolution measurements.

Leveled One Watt Sources: The maximum leveled power from any of the 1 to 12.4 Gc systems previously described can be increased to 1 watt using suitable traveling wave tube (TWT) amplifiers. An example of a crystal leveled, 1 watt system is shown in Figure 10. Note the system uses the same sweep oscillators and directional detectors as



ATTENUATION



IMPEDANCE REFLECTION COEFFICIENT



POWER

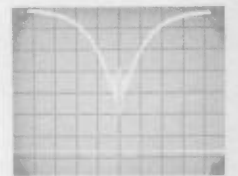

FREQUENCY

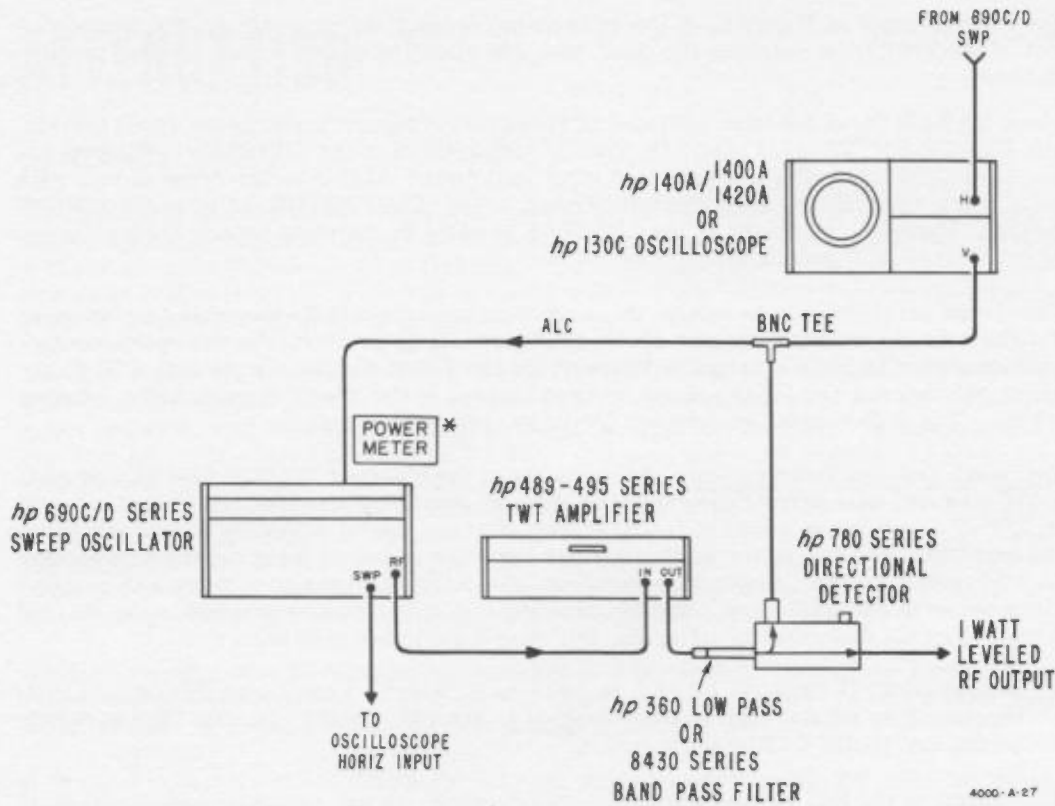

* ALC connects to 690C/D "POWER METER" input. Set ALC POWER LEVELING INPUTS to XTAL. See text.

INSTRUMENT	FREQUENCY - GC			
	1 - 2	2 - 4	4 - 8	8 - 12.4
Sweep Oscillator	691C/D	692C/D	693C/D	694C/D
Filter	360C	360D	8435A	8436A
Traveling-Wave Tube Amplifier	489A	491C	493A	495A
Directional Detector	786D	787D	788C	789C
Leveled Power Available (into 50 Ω)	1 w	1 w	1 w	1 w
Leveled Power Variation** (db - approx)	±0.4/0.3	±0.4/0.3	±0.5/0.4	±0.7/0.6

** Leveling is typically better than listed over most of the band except for variations at low-band edges of 1 - 8 Gc systems. Slightly larger variations are due to high frequency cutoff characteristics of filters.

Figure 10. Crystal leveled 1-watt sources from 1 to 12.4 Gc in coax. Waveguide systems from 2.6 to 12.4 Gc may also be assembled by substituting appropriate waveguide components for coupling and detection in the ALC loop.

shown previously in Figure 5. A low pass or bandpass filter prevents second harmonics out of the TWT from entering the ALC loop and affecting output power leveling performance.

Since the directional detector operates at substantially higher power in the 1 watt system, the POWER METER ALC input (1K ohm) is used instead of the CRYSTAL (10K ohm) input on the 690C/D. The power meter input load on the ALC detector reduces loop gain to a more convenient range for adjustment. The ALC POWER LEVELING INPUTS switch, however, is placed in the CRYSTAL position to maintain proper frequency response in the ALC amplifier. *

For 1 watt leveled power in waveguide, substitute the appropriate waveguide components for the coax directional detector shown in Figure 10. In general, the waveguide configuration shown in Figure 6 can be followed for the 1 watt system except that a 20 db directional coupler (hp 752D-series) is used instead of the 10 db coupler and a filter is added. The 3 db coupler is retained for super-leveling as before.

One Watt Leveling Instructions: Adjustments of the sweeper POWER LEVEL and ALC GAIN are mutually inter-dependent and become somewhat more critical when the gain of a TWT amplifier is added to the ALC loop. Excess power at the TWT input can drive the amplifier into saturation so that further increase of power input causes a reduction in TWT output power. Under this condition, the ALC feedback is positive and oscillations occur in the ALC loop. Stable operating conditions can be reached in the leveled 1 watt systems described by using the following adjustment procedure:

1. Preset 690C/D POWER LEVEL to "5", ALC "GAIN" and coarse POWER LEVEL (screwdriver adjust) fully counterclockwise. Set TWT "GAIN" for "RATED POWER" on the CATHODE CURRENT meter.
2. Observing the full band sweep on the oscilloscope, slowly increase ALC GAIN until pattern is level. If oscillations occur, continue increasing ALC GAIN until oscillations just cease.
3. Increase POWER LEVEL until 690C/D leveling indicator begins flashing then back off adjustment slightly for a steady indication.
4. If oscillations occur after the adjustment of step 3, reduce ALC GAIN as required to restore leveled operation. If oscillations do not occur after step 3, increase ALC GAIN for best leveling at the desired power level without oscillations.

Note: When crystal leveling, a suitable power meter such as the hp 431B connected to the system output will assist in optimizing leveling to the desired power. Use a 20 - 30 second sweep time on the 690C/D for an accurate power indication on the 431B and 20 db of attenuation ahead of the 478A or 486A thermistor mount.

Better Leveling: The leveling capability of the systems illustrated in Figure 5 through 10, and later in the applications sections, is determined by several factors. Where directional detectors are used, leveling depends upon the overall frequency response of the detector and the gain of the ALC amplifier. Where separate couplers and detectors (crystal or thermistor) are shown, leveling performance is dependent upon coupling variation, detector frequency response (crystal), coupler-detector mismatch, and ALC amplifier gain.

The level variations shown for each system are those resulting from the maximum effect of the error sources present in the leveling loops assembled from the components shown. However, the error effects in such leveling loops are primarily vector quantities having phase relationships which vary with frequency and do not always cause maximum error. Rather, total error is more usually the rms of the error quantities. Therefore, leveling is typically better than indicated, but the figures given permit comparison of the various systems illustrated.

On special order, HP will supply complete leveling systems with better leveling performance guaranteed. Inquiries on such systems may be directed to your HP Sales Office. A complete listing of HP Sales Offices may be found at the end of this Application Note.

* See Operating and Service Manual on hp 690C/D for circuit detail.

ATTENUATION

GENERAL

Attenuation is defined as the decrease in power level (at the load) caused by inserting a device between a Z_0 source and load^{8,9}. Under this condition, the measured value is a property of the device alone so that this is the "ideal system" in which to make measurements. The term Z_0 is used to describe a unity SWR condition where the load and source impedances equal the transmission line impedance.

There are three common methods for measuring RF attenuation: 1) square-law detection with audio substitution, 2) linear detection with IF substitution, and 3) direct RF substitution using attenuators calibrated with either of the first two methods. Accurate square-law measurements over a range of 30 db in a single step are possible using modern crystal detectors such as the hp 423A coax, and 424A-waveguide series. With partial RF substitution this range can be extended to about 45 or 50 db. With direct RF substitution a 45 or 50 db range is possible using the same detectors without square-law loading for highest sensitivity. The 423A and 424A Detectors are well suited to swept-frequency attenuation tests with either method 1 or 3 listed above because of their flat frequency response and low reflection coefficient (ρ) across the band.

Linear detection with IF substitution is capable of accurately measuring larger single step and total attenuation but is generally limited to fixed frequency operation and therefore, will not be discussed further in this Note.

A number of factors affect the range and accuracy of square law or RF substitution attenuation measurements, each of which must be evaluated for the particular setup used. The measuring system must have low source and load reflections to minimize mismatch error. Tuners cannot be used to cancel source or load reflections in swept frequency measurements because the tuning is effective only at single frequencies. Pads or isolators could be employed at the source but closed loop leveling is a much more effective way to reduce source mismatch using hp 690 Sweep Oscillators. By leveling the output power of the sweeper at the point of measurement, source impedance is effectively maintained very close to Z_0 ¹⁰. With this arrangement, impedance variations in connecting cables, connectors, and adapters are effectively cancelled since they are within the leveling loop.

Low reflections in the crystal detector are important for reducing mismatch error at the load in the measurement system. All hp detectors are swept frequency tested to assure low reflections throughout their specified band. The following system configurations are arranged to further reduce load mismatch by padding the detector. By keeping source and load reflections low over a broad band, we can approach the "ideal system" for swept frequency attenuation measurements. Typical figures for accuracy and range will be given in the examples that follow.

MEASUREMENTS IN WAVEGUIDE

A. Basic Operation. Figure 11 shows a waveguide system for swept attenuation measurements of 30 to 40 db. Source power is leveled using a single 10-db directional coupler in the ALC loop. Coupling variation versus frequency in the leveling loop results in a leveled power variation of about 1 db at the point of test-device insertion. This power variation is nearly equal to but opposite the coupling variation in the readout coupler. The net variation in readout calibration is therefore mutually compensated to within about 0.3 db in X-band depending primarily on coupler tracking.

⁸ Beatty, R. W., "Intrinsic Attenuation," Trans. IEEE, Vol. MTT-11, No. 3, May 1963, p. 179

⁹ Beatty, R. W., "Insertion Loss Concepts", Proc. IEEE, Vol. 52, No. 6, June 1964, p. 663

¹⁰ Engen, G. F., "Amplitude Stabilization of a Microwave Signal Source." IRE Trans on MT and T, April 1958, p. 202.



ATTENUATION

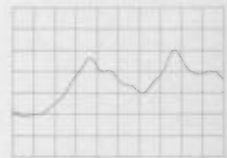

IMPEDANCE
REFLECTION
COEFFICIENT



POWER



FREQUENCY

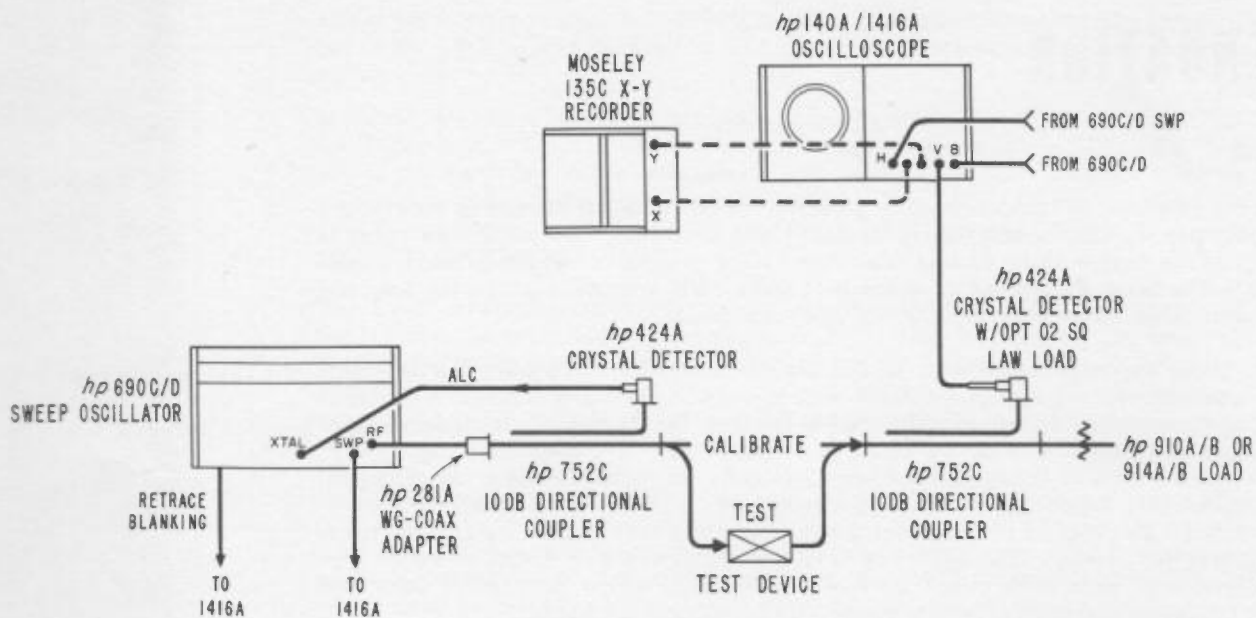

Figure 11. Swept attenuation system for measurements up to 40 db with oscilloscope or X-Y Recorder readout.

With the hp 690C/D sweeping the band, a zero-db reference level is established on the oscilloscope without the test device in the system. The device is then inserted as indicated in Figure 11 and its attenuation versus frequency determined by the amplitude decrease from the CRT reference level previously established. Attenuations of 20 to 35 db may also be made on a conventional 200 $\mu\text{v}/\text{cm}$ dc oscilloscope instead of the 1416A by using the CRT attenuation overlay furnished with this Note. Oscilloscope readout of attenuation measurements is especially useful for viewing broadband performance of test devices while adjustments are being made or for rapid testing applications.

B. System Calibration. To measure attenuation in waveguide, connect the equipment as shown in Figure 11 and proceed as follows:

- With the 690C/D in STANDBY, set up the oscilloscope to accept dc inputs to the vertical and horizontal axes making the required FOCUS, INTENSITY, and DC BALANCE adjustments. Set 1416A SENSITIVITY to 5 mv/cm, MODE to LINEAR, and vertically position the trace at the bottom graticule line. When using a conventional oscilloscope such as the hp 130C, set vertical sensitivity to 5 mv/cm and vertically position the trace 3 cm above the center graticule line.
- Preset the 690C/D POWER LEVEL control to "5" and the inner screwdriver adjust fully CCW. Set 690C/D controls for automatic sweep between desired band limits without AM and depress ALC button.
- Turn sweeper LINE to RF and gradually increase the RF output with the POWER LEVEL (screwdriver) control until the 140A/1416A indicates 50 mv vertical deflection (10 cm).

- When using the db scale with conventional oscilloscopes, increase POWER LEVEL control until trace is vertically deflected 3 cm below the center graticule line. DO NOT ADJUST VERTICAL POSITION for this step and do not take oscilloscope VERNIER out of CALIBRATED position.
- The 690 POWER LEVEL indicator should now indicate a leveled RF output.
- Adjust oscilloscope HORIZONTAL SENSITIVITY for a full 10 cm display of the sweep output voltage from the 690C/D.
- When using the 1416A, set the MODE control to LOG, SENSITIVITY to 10 db/cm, ATTENUATION-DB to zero, and VERTICAL POSITION for a convenient reference on the CRT. Increase vertical sensitivity from 10 db/cm to 1 db/cm and adjust REFERENCE SET to restore trace position to the reference level on the graticule*. The hp 140A/1416A is now calibrated for direct readout in db/cm.

For conventional oscilloscopes, proceed with the following step:

- Cut the transparent db scale for either visual observation or CRT photography from the foil

* 1) The Reference Set adjustment reacts the same as a dc balance adjustment on a linear dc oscilloscope. The idea is to prevent the entire trace from shifting as sensitivity is increased. 2) Because of increased resolution, imperfections in the overall leveling system are magnified causing the trace to deviate somewhat from a straight line. Use the vertical position and reference set controls to place the mean over the reference level on the graticule so leveling imperfections are averaged out.

included with this Note. Place scale over the CRT carefully aligning the 3 db mark with the center graticule line. Use electrostatic charge or a few small spots of rubber cement to secure scale to CRT face. The oscilloscope is now calibrated for db readout.

C. Measurement.

- Insert the test device into the system as indicated in Figure 11.
- When using the 140A/1416A, the ATTENUATION-DB control may be used for readout in two ways depending on the application and preference of the operator. For high resolution measurements at specific points on the display, increase VERTICAL SENSITIVITY as desired (0.5 db/cm maximum) and increase ATTENUATION-DB until the trace is coincident with the reference level. Read attenuation directly from the calibrated ATTENUATION-DB dial. For fast measurements such as go-no-go tests, leave the ATTENUATION-DB control at zero. Attenuation of the test device is now the amplitude decrease from the vertical reference as read from the calibrated CRT graticule. Figure 12(a) is a typical presentation of attenuation across X-Band as viewed on the 140A/1416A.
- When using a conventional oscilloscope, read attenuation directly from the transparent db scale. For best resolution, increase VERTICAL SENSITIVITY in calibrated steps to position the trace near, but still above, the 0 db mark. Calculate the ratio of vertical sensitivity increase, and add the corresponding correction in db from Table 1 to the reading indicated on the scale. Figure 12(b) shows the type of presentation obtained with a standard oscilloscope and the db scale overlay.

TABLE 1

Ratio of Sensitivity Increase - E_2/E_1^*	Correction in DB (add to scale reading)
1.0	0
.5	3
.2	7
.1	10
.05	13
.04	14
.02	17
.01	20

* E_1 = Vertical sensitivity in mv/cm for reference setting.
 E_2 = Vertical sensitivity in mv/cm giving best test resolution.

D. Extended Range. An additional 6 to 10 db of attenuation range can be obtained with somewhat lower accuracy by adding one instrument to the setup in Figure 11. All steps of the foregoing procedure remain unchanged except that an hp 382A variable attenuator is inserted ahead of the leveling detector and set to zero db. When the test device is inserted into the system and attenuation is greater than the available range of readout, the 382A is increased by an amount necessary (up to about 10 db on 690D series and about 6 db on 690C) to get on-scale readings. This increases the RF power out of the sweeper by an amount equal to the attenuation increase. The amount of db increase on the 382A is added to the db reading noted on the oscilloscope for total attenuation of the test device.

E. X-Y Recording the 140A/1416A Display. After the measurement system is adjusted for normal operation with the 140A/1416A oscilloscope, an X-Y plot of attenuation versus frequency may be made on linear graph paper as follows:

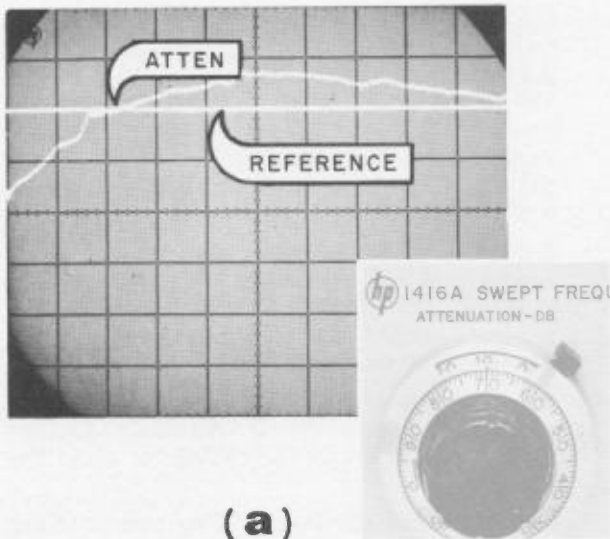

(a)

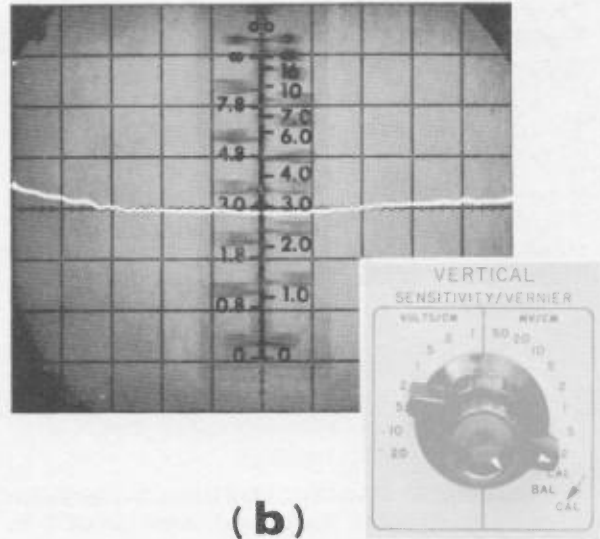

(b)

4000-A-27

Figure 12. (a) Swept attenuation test of an hp X375A Variable Attenuator as viewed on hp 140A/1416A. Vertical Sensitivity is 0.5 db/cm - Reference: 17 db. (b) Same device with readout on hp 130C using db scale overlay. Add 14 db to scale reading because of vertical sensitivity increase from 5 mv/cm to 200 μ v/cm from Calibrate to Test conditions.

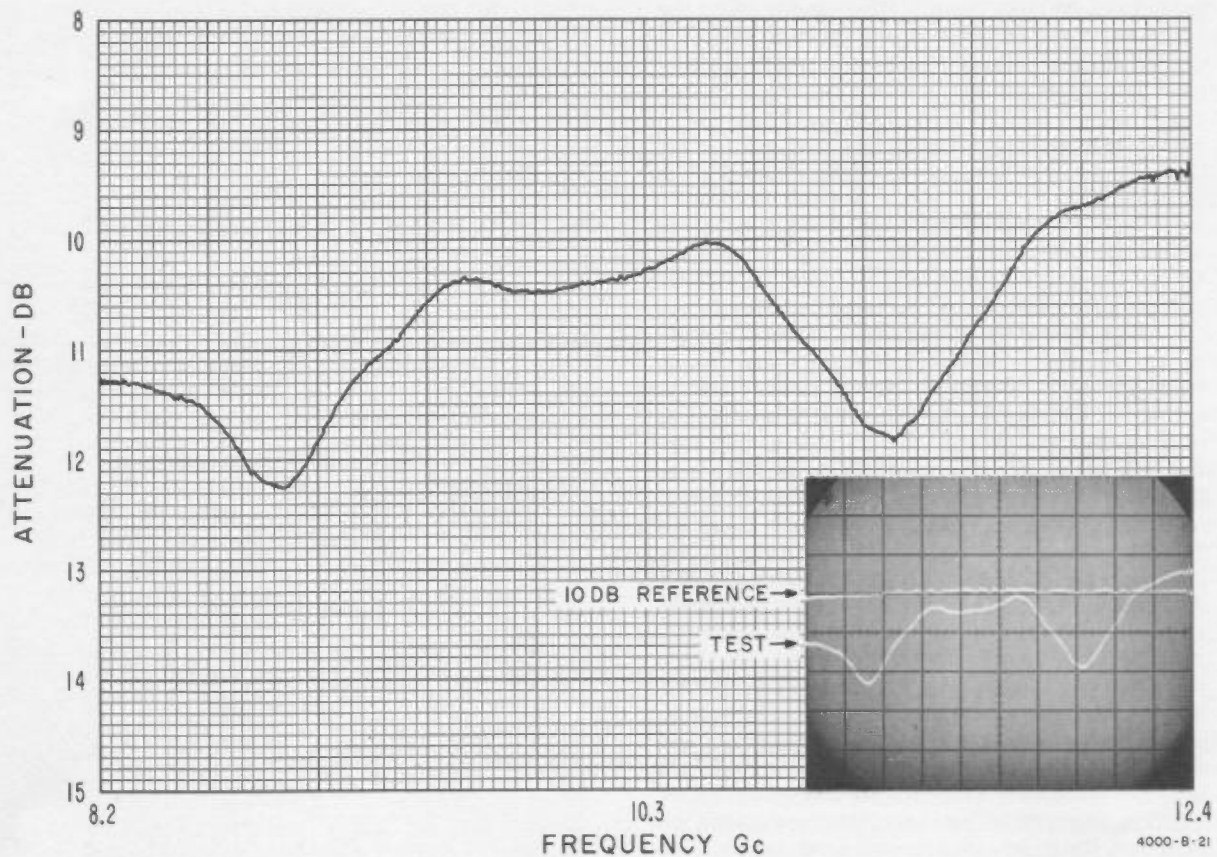

Figure 13. X-Y plot of attenuation on linear graph paper.

- With the recorder turned OFF, connect the X and Y inputs to the 1416A HORIZ and VERT outputs. Set 690C/D SWEEP SELECTOR to MANUAL SWEEP and MANUAL SWEEP fully-counter-clockwise.
- Set 1416A MODE to CAL(db) - 0 and sensitivity to 10 db/cm. Preset RECORDER OUTPUT AMPLITUDE and DC LEVEL controls to mid-range.
- Set X-Y recorder VERTICAL SENSITIVITY to approximately 0.1 v/inch (or about 50 mv/cm on metric scaled recorders) and HORIZONTAL SENSITIVITY to 50 mv/inch (approximately 20 mv/cm). *
- Turn ON the X-Y recorder and position the pen over the desired 0 db (vertical) and start-frequency (horizontal) reference point on the graph paper using the recorder zero controls or 1416A DC LEVEL controls.
- Turn 690C/D MANUAL SWEEP fully clockwise and adjust 1416A horizontal AMPLITUDE to

position pen to desired STOP-FREQUENCY reference. Check and readjust zero at START-FREQUENCY reference if necessary. The recorder horizontal span is now calibrated.

- Set 1416A MODE successively to -10, -20 and -30 db and adjust 1416A RECORDER OUTPUT vertical AMPLITUDE so pen moves the desired number of vertical divisions on the graph paper. Check and readjust vertical zero (at 0 db) if necessary.
- Set 1416A MODE to LOG. The recorder vertical span is now calibrated in db/division corresponding to the 1416A SENSITIVITY. The recorder's vertical zero point may now be readjusted to any desired reference on the graph.
- Insert the test device into the measurement system and set the 690C/D SWEEP SELECTOR to TRIGGER. Set SWEEP TIME for about 20-30 seconds.
- With the 1416A SENSITIVITY set to the desired vertical calibration, push the MANUAL TRIGGER on the 690C/D and record the test results. Attenuation at any frequency in the sweep is read directly in db from the graph.

*The recorder output voltages furnished by the 1416A are continuously variable from 0 to 200 mv/cm of oscilloscope vertical display, and 0 to 100 mv/cm horizontal. This allows use of low-cost single range X-Y recorders instead of multi-range instruments if preferred.

Figure 13 shows an attenuation measurement in X-Band made on standard graph paper using the 140A/1416A

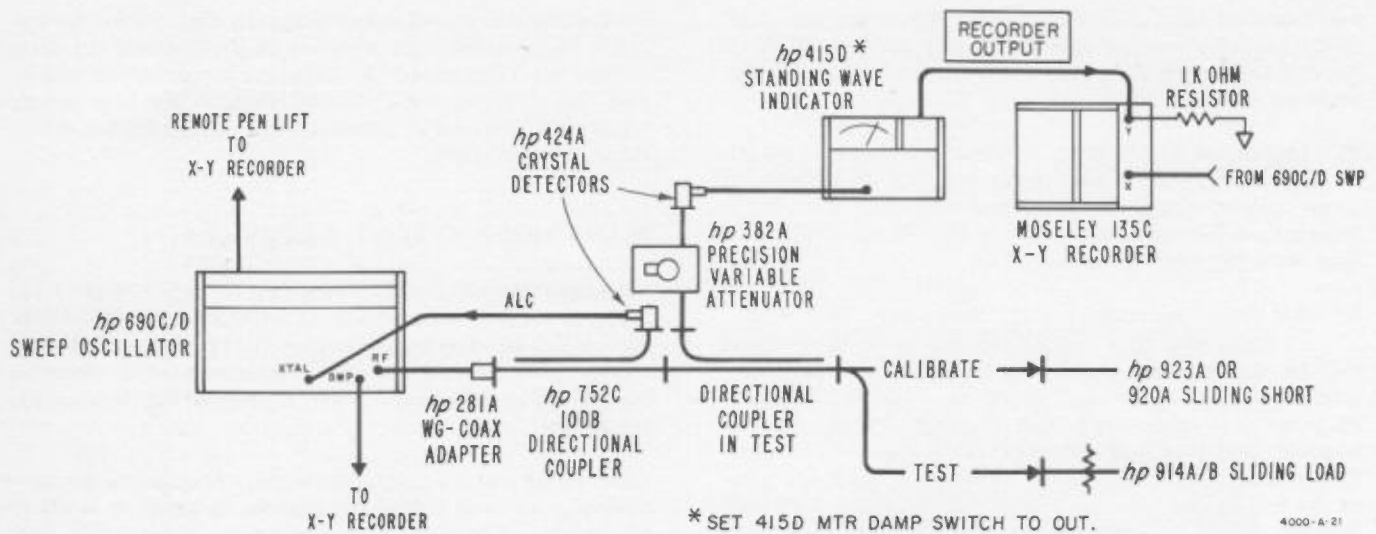

Figure 15. Swept frequency directivity measuring system for waveguide directional couplers. High sensitivity 415D amplifies low level directivity signal from test coupler and feeds proportional dc voltage to X-Y Recorder.

Total attenuation range using a 10 db reference setting in Figure 13 is reduced to 35-40 db, but accuracy improves to about $\pm(0.1 \text{ db} \pm 0.02\alpha)$.

Accuracy of X-Y recording from the 140A/1416A on linear graph paper is the same as the accuracy given for oscilloscope readout with the 140A/1416A.

DIRECTIVITY MEASUREMENT

Directivity of a directional coupler is the ratio, expressed in db, of forward to reverse power in the secondary arm when all of the power in the main arm is flowing in the forward direction. Precision multi-hole directional couplers such as the hp 752 series have directivities of 40 db minimum throughout their operating band and often run as high as 46 db. In order to make swept directivity measurements on these couplers, use the setup shown in Figure 15. The 415D Standing Wave Indicator is used for amplifying the detected signal to obtain maximum sensitivity. When using the 415D, the sweeper output must be amplitude modulated at 1 kc. The PIN modulated 690D series sweep oscillators are especially well suited to this application because of their superior amplitude stability during the combined operation of leveling and modulating. The dc recorder output from the 415D in turn drives the X-Y recorder.

With the short connected as shown in Figure 15, the 382A variable attenuator is set to specific values of attenuation near the anticipated directivity of the coupler in test. Calibration grid lines are plotted on the recorder at each attenuator setting. For better accuracy, use an hp 923A short whenever possible instead of the 920A and rapidly phase the short during each calibration sweep. Now the attenuator is returned to

zero and the calibrating short replaced with a degraded sliding load*

With the 690C/D set for about a 40 second sweep time, a final sweep is triggered and the sliding load continuously phased back and forth during the sweep.

By sliding the load and sweeping slowly, all possible phase combinations of the true directivity signal and the load reflections are encountered. Thus, the combined signal arriving at the reverse detector swings between the vector sum and difference of the two signal components. If the swing is small as shown throughout most of Figure 16, the load reflection is small compared to the directivity phasor. Under these conditions, a good approximation of the true directivity is the average of the swing plus the effect of transmission loss of the coupler. For example, if a 3 db coupler were being measured, a 3 db transmission loss would be added to the average value noted in Figure 16 to arrive at the true directivity. For a 10 db coupler, add 0.46 db, for a 20 db coupler the transmission loss effect is only 0.04 db which can be ignored in the measurement of directivity.

For a more precise determination of directivity after the swept test, use the 690C/D MANUAL SWEEP function to run the recorder back to the frequency of interest. Again short the coupler output, and with the 382A attenuator set to 40 db establish a convenient reference level on the 415D using the RANGE and GAIN controls. Replace the short with the sliding load and decrease the 382A attenuator for an on-scale reading. Slide the load for a minimum and maximum

*An hp 914B can be degraded by securing a 1/4" piece of #22 bare wire to the side of the tapered load with cellophane tape. The longitudinal position of the wire can be determined experimentally to give a return signal level near the anticipated directivity signal.

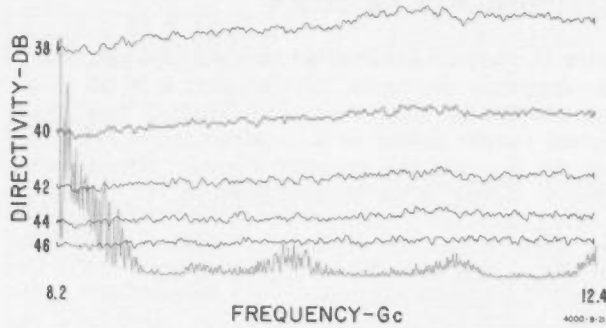

Figure 16. Typical swept frequency directivity test on precision multi-hole directional coupler. Calibration grid is plotted on X-Y Recorder using hp 382A Attenuator.

reading on the 415D noting each level in total db below the original reference level, the total being the

combination of 382A decrease and 415D reading. Take the difference in db between the two levels noted and enter the ordinate of the separation chart of Figure 17. Intersect the two curved coordinates in the chart and note the correction in db below each intersection.

Add these two corrections separately to the MINIMUM DB reading noted in the sliding load test. The two figures resulting represent the actual values of the coupler directivity, and the load return loss. If both values plus the coupler transmission loss effect are greater than the specified directivity of the coupler, no further tests are required. If one reading does not meet the desired specification, repeat the sliding load test with another load or coupler. One reading from each pair of separated signal levels will agree, thus identifying the component retained in both tests. A logical point in Figure 16 for this latter test would be at the low-band edge where directivity is questionable on the swept test.

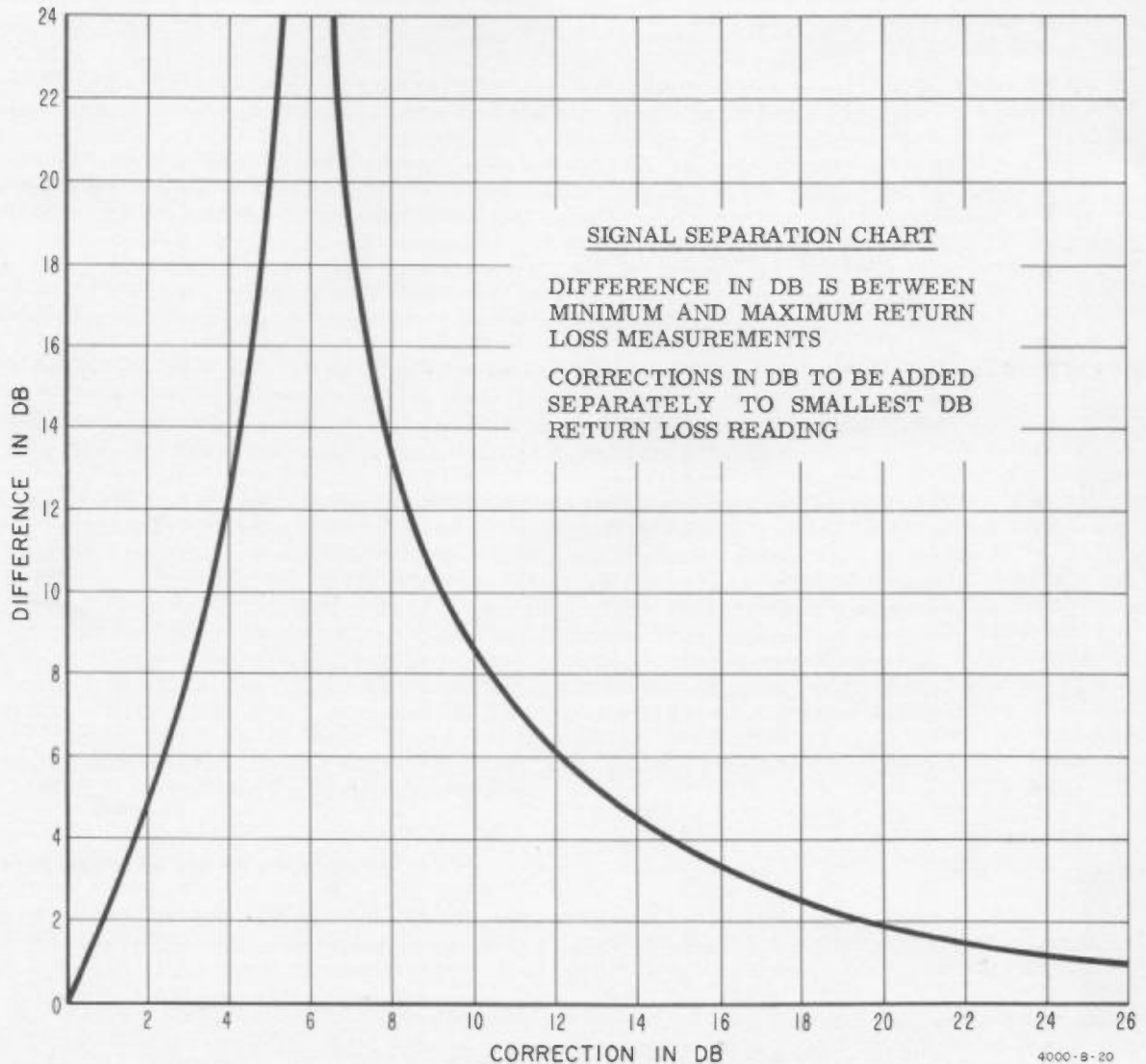

Figure 17. Chart for separating two signals when their sum and difference is known.

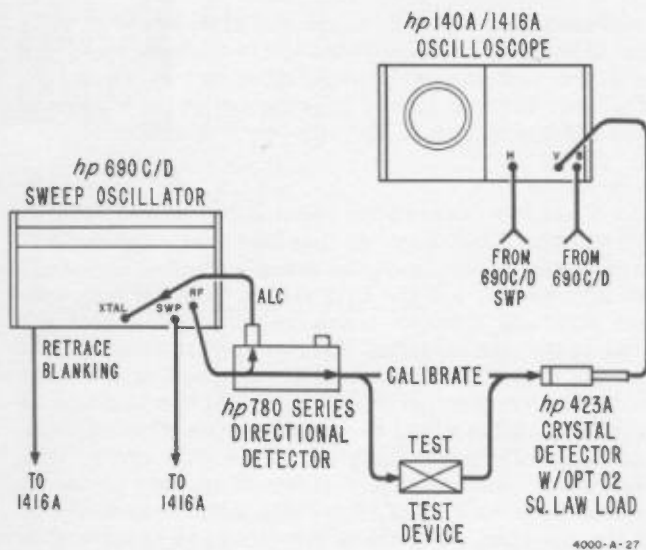

Figure 18. Coaxial attenuation tests to 30 db can be made using hp sweep oscillators and directional detectors in any of four bands from 1 to 12.4 Gc. Separate coupler and detector may be used for 500 Mc - 1 Gc range.

MEASUREMENTS IN COAX

Figure 18 shows a general set up for swept attenuation measurements of coaxial devices over a 30 db range, from 500 Mc to 12.4 Gc in five bands. Essentially constant output power is maintained at the reference point by leveling the sweeper output. The leveling feedback signal is derived from an hp 780 series directional detector in all but the lowest band. The leveling arrangement of Figure 18 effectively reduces source ρ to that of the directional detector main line ρ . Flat frequency response in the directional detector minimizes power variations in the reference output providing constant calibration of the oscilloscope display across the band. Measuring and readout procedures are identical to those described earlier for waveguide systems.

COAXIAL SYSTEM ACCURACY

Typical accuracy of a coaxial attenuation measuring system as shown in Figure 18 will be on the order of $\pm(0.8 \text{ db} + \text{readout error})$. Sources of error include: Effective source ρ , load ρ , and deviation from square-law detection.

IMPEDANCE

GENERAL

One of the most widely used swept frequency systems is the reflectometer for measuring reflection coefficient (or SWR) in coax and waveguide. The basic function of the reflectometer is to sample the individual magnitudes of the incident and reflected signals in a transmission line feeding an unknown load impedance. The ratio of these signals indicates how well the load impedance matches that of the transmission line. Equations 1, 2 and 3 relate the common expressions used in reflectometer measurements.

$$\text{Reflection Coefficient Magnitude } \rho = \frac{|E_{\text{reflected}}|}{|E_{\text{incident}}|} \quad (1)$$

$$\text{Standing Wave Ratio } \text{SWR} = \frac{(1 + \rho)}{(1 - \rho)} \quad (2)$$

$$\text{Return Loss* } \text{DB} = -20 \log_{10} \rho \quad (3)$$

*Return loss expresses the relative amplitude decrease in the reflected signal level when a 100% reflection is replaced by the load in test.

From this fundamental discussion, it may be noted that the directional couplers separating and sampling the incident and reflected signals must have high directivity and low port reflections to achieve accurate results. Furthermore, the couplers should maintain these qualities over broadbands in order to work with swept techniques. For waveguide measurements in the 2.6 to 40 Gc bands, the hp 752 series of directional couplers are recommended. These couplers provide at least 40 db directivity across the band with a main guide SWR of 1.05 or less. For coax measurements in the ranges up to 4 Gc, use the hp 770 series of coax dual directional couplers. These couplers provide incident and reflected sampling in one integrated unit which eliminates large coax connector ambiguities between two individual couplers. All hp directional couplers are swept frequency tested in production to assure that they meet specifications at all points within the band; a pre-requisite for accurate swept reflectometers.

Special techniques may be used to adapt high directivity waveguide couplers for coax measurements at higher frequencies where coax coupler directivity is typically too low for accurate results. These techniques are used in the hp X8440A Reflection Coefficient Bridge for accurate swept reflection tests in coax at X-Band frequencies.

The accuracy of a reflectometer measurement depends not only on how all instruments perform individually, but as a system as well. For example, close tracking between the forward and reverse couplers and detectors in the reflectometer is essential to effective leveling. Consistently high directivity in both couplers is required to minimize ambiguities in separating incident and reflected waves. With load impedance varying anywhere from a short to nearly reflectionless terminations, sweeper leveling performance must be stable over a large range to prevent frequency and amplitude calibration shift during a measurement. Accurate reflection measurement systems, as shown in this section, can be assembled from unselected HP instruments because of their design and consistent manufacture. However, for special applications, HP also offers complete systems that are matched for best overall performance. Contact your HP Sales Office listed at the end of this Note for system information.

MEASUREMENTS IN WAVEGUIDE

A. Basic Operation. The system shown in Figure 19 is the most straightforward method for waveguide reflection measurements and uses the same equipment shown earlier in Figure 11 for swept attenuation tests. A waveguide short for calibration purposes is the only additional equipment necessary.

The basic idea of this system is to hold forward power constant by leveling and measure RETURN LOSS of a given load rather than a direct ratio of the incident and reflected signals. This technique eliminates need for a ratiometer and 1 kc amplitude modulation of the sweeper output which was typical in older reflectometer setups. The calibrating



ATTENUATION

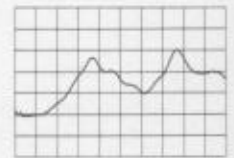

IMPEDANCE REFLECTION COEFFICIENT



POWER



FREQUENCY

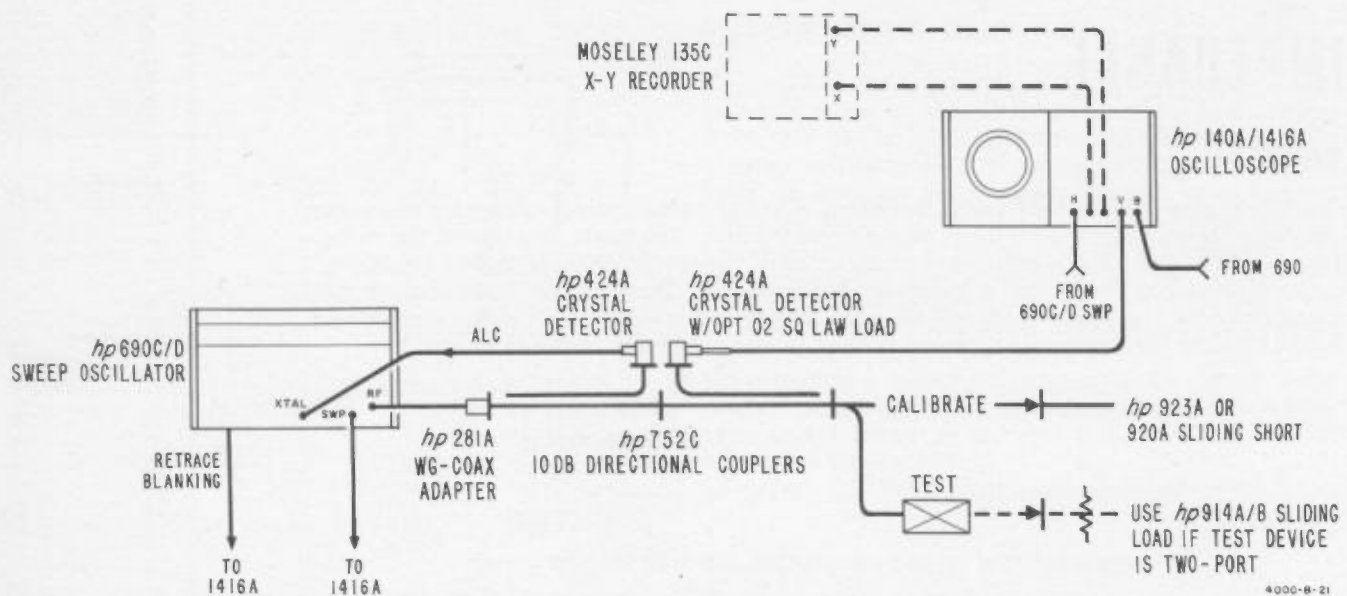

Figure 19. Waveguide reflectometer with oscilloscope readout

short is placed on the reflectometer output to set up a 100% reflection to the reverse coupler detector as the 690C/D rapidly sweeps the band. After a dc amplitude reference from the reverse detector is established on the oscilloscope, the short is replaced by the unknown load. The amplitude decrease on the oscilloscope indicates the load RETURN LOSS which is easily converted to ρ or SWR using the relationships of equations 2 and 3 or the HP Reflectometer Calculator*

The square-law characteristics of the reverse detector must be good over the full dynamic range of the return loss measurement to minimize error. The hp 424A with its matched square-law load (option 02) is recommended for close adherence to square law from low levels up to 50 mv dc output allowing return loss measurements of 30 db with the particular system shown. Greater range is possible using the RF pre-insertion techniques described later. Square-law loading the leveling detector on the forward coupler is not necessary because the power level at that point is held constant by the leveling circuit. Typical accuracies for the various techniques described are given in each example that follows.

B. System Calibration. To measure ρ (or SWR) in waveguide components, connect the equipment as shown in Figure 19 for "CALIBRATE" and proceed as follows:

- With the 690C/D LINE in STANDBY, set up the oscilloscope to accept dc inputs to the vertical and horizontal axes. Make required FOCUS INTENSITY, and DC BALANCE adjustments. Set 1416A sensitivity to 5 mv/cm and MODE to LINEAR, and vertically position the trace at

the bottom graticule line. When using a conventional oscilloscope, such as the hp 130C, set vertical sensitivity to 5 mv/cm and vertically position the trace 3 cm above the center graticule line.

- Preset the POWER LEVEL control on the 690C/D to "5" and the coarse POWER LEVEL (screwdriver adjustment) full CCW. Set 690C/D for automatic sweep between desired band limits and depress the ALC button.
- Turn sweeper LINE to RF and gradually increase the RF output with the coarse POWER LEVEL (screwdriver) control until the 140A/1416A indicates 50 mv vertical deflection (10 cm).
- When using a conventional oscilloscope and the SWR scales included with this Note, increase coarse POWER LEVEL until trace is vertically deflected 3 cm below the center graticule line. DO NOT ADJUST VERTICAL POSITION for this step, and do not take oscilloscope VERNIER out of the CALIBRATED position. The 690C/D POWER LEVEL indicator should now indicate a leveled RF output.
- Adjust oscilloscope HORIZONTAL SENSITIVITY for a full 10 cm display of the sweep output voltage from the 690C/D.
- When using the 1416A, set the MODE control to LOG, SENSITIVITY to 10 db/cm, ATTENUATION DB to zero, and VERTICAL POSITION for a convenient reference on the CRT. Increase VERTICAL SENSITIVITY and restore trace position with the REFERENCE SET. The hp 140A/1416A is now calibrated for readout in DB RETURN LOSS.

*The HP Reflectometer Calculator is a slide-rule type aid that allows direct conversion between db return loss, reflection coefficient and SWR without calculations. The calculator also provides other useful microwave data and is available on request from your HP Field Engineer or HP Sales Office.

For best accuracy, use the hp 923A sliding short when setting the 100% reflection reference on the oscilloscope. The 923A allows rapid phasing so the mean of the reference trace can easily be observed and set to the reference graticule using the sweeper POWER LEVEL control.

C. Measurement. After completing the calibration procedure of paragraph B, remove the calibrating short and proceed as follows:

- Connect the test load to the reflectometer output as shown in Figure 19 for "TEST".
- When using the 140A/1416A, read RETURN LOSS in db directly from the calibrated display (decrease of trace from reference), or use the ATTENUATION DB dial to return trace to the reference level at the point of interest and note db return loss from the dial calibration. Increase vertical sensitivity as required to obtain desired resolution.

For other oscilloscopes, increase vertical sensitivity until the entire trace is near, but still above the lower 3 cm graticule line. Note the ratio of sensitivity increase required on the oscilloscope VERTICAL SENSITIVITY control.

- Select the corresponding SWR scale from Table 2 and cut it from the transparent foil for either visual observation or CRT photography. Place scale over main CRT graticule using electrostatic charge or a few small spots of rubber cement to secure it in place. Be sure to align the small circle at the scale center with the center graticule lines of the CRT. Read SWR from scale at point of interest.

Example 1, Return Loss Measurement on hp Models 140A/1416A: With the reflectometer output shorted, a reference trace is established on the oscilloscope as shown by the upper trace in Figure 20(a). The short is replaced by the test load and the amplitude decrease noted from the calibrated graticule in db/cm. For higher resolution, the vertical sensitivity is increased to 2 db/cm and the ATTENUATION DB control increased until the trace position is restored to the reference level as shown in Figure 20(b). The calibrated ATTENUATION DB dial now reads RETURN LOSS at

TABLE 2

Ratio of Sensitivity Increase - E_2/E_1^*	Use SWR Scale Marked
1.0	0 DB
.1	10
.05	13
.04	14
.02	17
.01	20

* E_1 = Vertical Sensitivity in mv/cm for reference setting.
 E_2 = Vertical Sensitivity in mv/cm giving best test resolution.

the frequency of coincidence between the reference and test traces.

Return loss is now converted to ρ (or SWR) with the HP Reflectometer Calculator as shown in Figure 21 or calculated as follows:

$$\text{from equation (3) } DB = -20 \log_{10} \rho ;$$

transposing and substituting, the value of return loss measured

$$\rho = \log_{10}^{-1} \left(-\frac{17}{20} \right) \text{ or } .141 \text{ (SWR} = 1.33\text{)}.$$

Example 2, Direct SWR Readout Using Oscilloscope CRT Scales: Figure 22(a) is a double exposure showing the two trace positions for RF - off and 100% reflection conditions. When the calibrating short is replaced by the test load, the oscilloscope's vertical sensitivity is increased from 5 mv/cm to 0.2 mv/cm to obtain the trace shown in Figure 22(b). The RATIO of sensitivity increase is thus 0.04, calling for the SWR scale marked 14 db as indicated by Table 2. The SWR scale is placed on the CRT giving direct readout at any

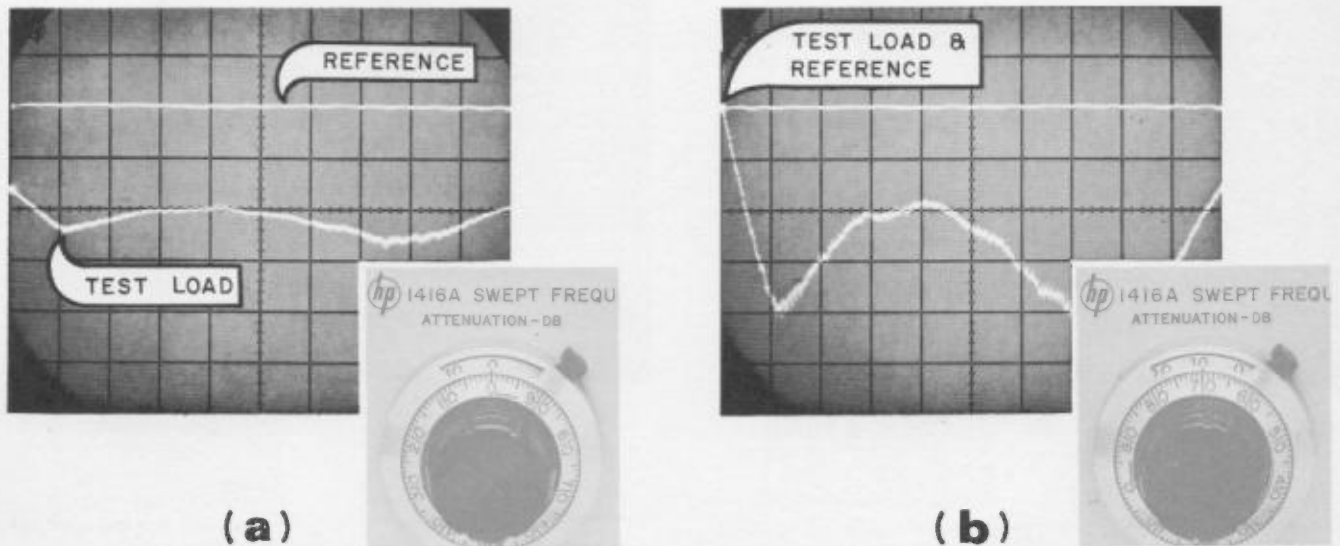

Figure 20. (a) Swept reflection test of a waveguide thermistor mount on hp 140A/1416A. Vertical Sensitivity is 10 db/cm - Reference: 0 db. (b) The same mount with vertical sensitivity increased to 2 db/cm and reference offset to 17 db.

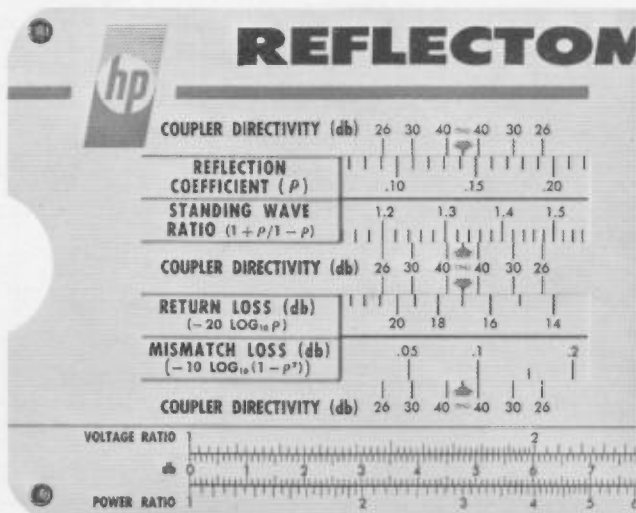

Figure 21. HP Reflectometer Calculator is used to convert 17 db return loss measured in example 1 to ρ or SWR.

frequency of interest. If desired, SWR may be converted to ρ with the Reflectometer Calculator.

X-Y RECORDING REFLECTION TESTS

In certain applications it is desirable to record reflectometer test results for future reference or detailed examination. In some cases, a photo of the oscilloscope display will satisfy the requirement. Many times, however, the high resolution and low cost of X-Y recording is preferable. After calibrating the reflectometer to the 140A/1416A display, an X-Y recorder may be connected as shown by the dashed line in Figure 19.

The recorder readout is conveniently set up to correspond to the oscilloscope display as outlined in the ATTENUATION section, paragraph "E". Now X-Y recordings of db return loss may be made on linear scaled graph paper by triggering a single 20 - 30 second sweep on the 690C/D. The ability to record on graph paper, as opposed to plotting a calibration grid, allows accurate readout of return loss without interpolating and also saves setup time.

RF PRE-INSERTION - X-Y RECORDER TECHNIQUE

Another accurate method for X-Y recording swept-reflection tests is to use a precision variable attenuator for calibration as shown in Figure 23. The sweeper output is amplitude modulated at 1 kc (to drive the 415D) and adjusted for a leveled indication while sweeping the band*. With the reflectometer output shorted, the 382A attenuator is adjusted to pre-insert specific values of RETURN LOSS to the reverse arm detector. Grid lines are sequentially plotted on the X-Y recorder at each attenuator setting by manually triggering single sweeps on the 690C/D. When using a sliding short such as the hp 923A, rapid phasing is possible during the slow calibrating sweeps. By continuously phasing the short during each calibrating sweep, all phases of source mismatch error signals are encountered at the reverse arm detector. The result is a fine grain variation on the grid lines which defines source mismatch limits within the ambiguity limits of the coupler directivity. Using the mean of the fine grain variations as the true return loss for each grid line, source mismatch error is removed and

*Leveled power out of some low band sweepers is sufficient to operate the readout detector at a high output level. In such cases the 415D may be eliminated from the setup and the sweeper left unmodulated.

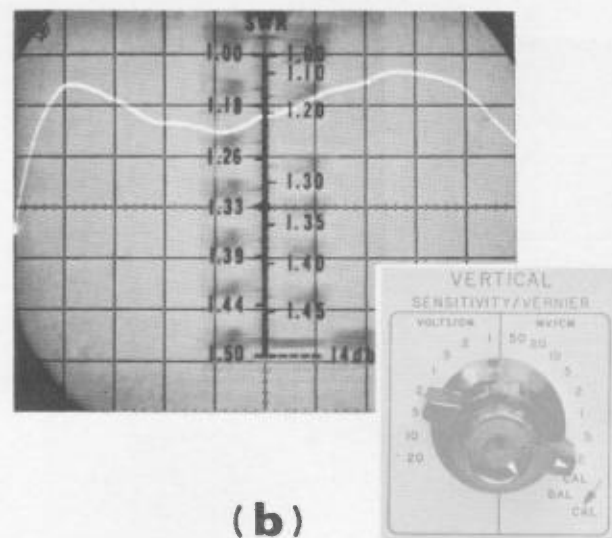
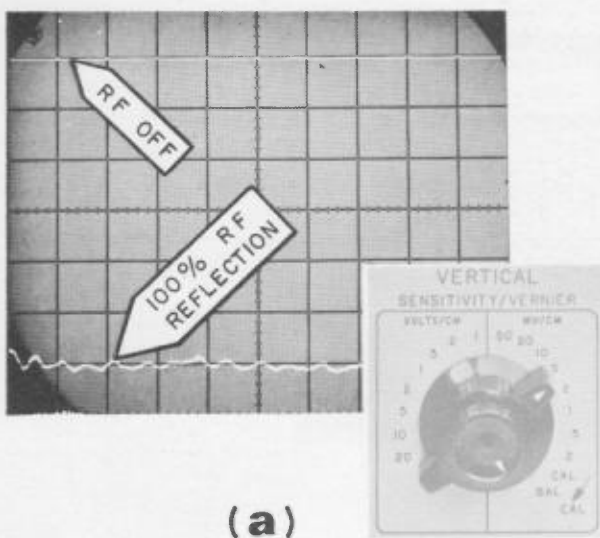

Figure 22. (a) Calibration traces for swept SWR tests using scale overlays, as viewed on hp 130C oscilloscope. Vertical sensitivity (inset) is set to 5 mv/cm and trace positioned 3 cm up, with RF off. Reflectometer is then shorted and RF power increased for trace deflection 3 cm down. (b) Swept SWR test of an hp X486A Thermistor Mount after oscilloscope has been calibrated. Vertical sensitivity (inset) is increased to 200 μ v/cm for better resolution. Ratio of sensitivity increase determines SWR scale used.

4000-A-27

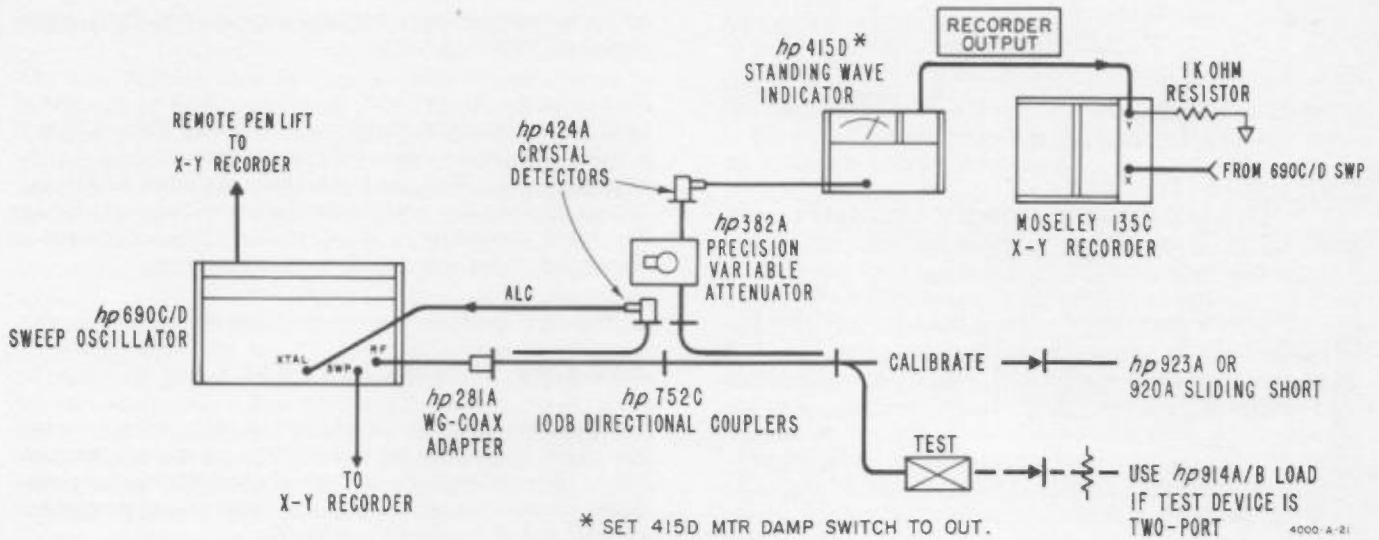

Figure 23. RF pre-insertion - X-Y Recorder setup for ρ tests.

better accuracy obtained in the measurement. In X-band, using the 923A short and other equipment shown, the improvement is about 0.6 db in the return loss measurement. The attenuator is then returned to zero and the short replaced with the test device.

Now the final sweep is triggered and return loss of the test device recorded over the calibration grid as shown in Figure 24. The calibration grid, once plotted, can be used as an underlay for many swept reflection tests by using translucent paper for the actual record of each device tested. Grid line calibration should be checked periodically during long hours of testing and a new grid always plotted when the system has been turned off.

This system, while slower than the oscilloscope readout, has the advantage of greater dynamic range due to the 415D amplification of the reflected signal. Return losses to 40 db ($\rho = .01$) can be measured, limited primarily by the system accuracy rather than resolution. Another advantage of this system is that it does not rely on the square-law characteristics of the

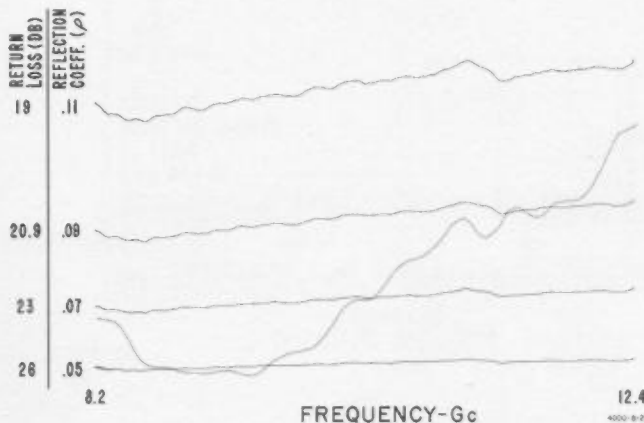

Figure 24. X-Y plot of return loss using RF pre-insertion technique

detector since the crystal operates near the same RF level for both CALIBRATE and TEST conditions. The attenuator, however, does introduce certain errors of its own which are subsequently discussed under "Waveguide System Accuracy".

WAVEGUIDE SYSTEM ACCURACY

For reflection coefficients less than 0.5, overall accuracy of the reflectometer shown in Figure 19 for X-Band is typically $\pm(.01 + .04\rho_L + K\rho_L)$ when the calibrating short is phased; where ρ_L is the actual load reflection coefficient and K is the decimal readout error of the indicating device, e.g., overall error for a .05 reflection coefficient using a 3% oscilloscope would be $\pm[.01 + .04(.05) + .03(.05)]$ or $\pm.0135$. This decreases to $\pm(.01 + .07\rho_L + K\rho_L)$ when the short is not phased. Sources of error include effective source ρ , reverse coupler directivity, imperfect short, detector deviation from square law and differences of coupling coefficients and detector frequency response between forward and reverse detector/coupler system.

Detector square-law error may be eliminated by using the RF pre-insertion technique shown in Figure 23. However, the variable attenuator used for calibration introduces error of its own which must be accounted for. Overall accuracy of the reflectometer system shown in Figure 23 is approximately $\pm(.01 + .05\rho_L)$ when the calibrating short is phased during the grid line plots. When a fixed short is used for calibration, the accuracy decreases to about $\pm(.01 + .08\rho_L)$. Sources of error include effective source ρ , reverse coupler directivity, imperfect short, attenuator error, and mismatch error of the reverse detector.

It may be noted that the typical leveled reflectometer accuracy given above is as good as any HP slotted line measurement which gives only spot frequency data. For this reason, swept frequency tests no longer need to be verified at spot frequencies with a slotted line as was often done in older systems.

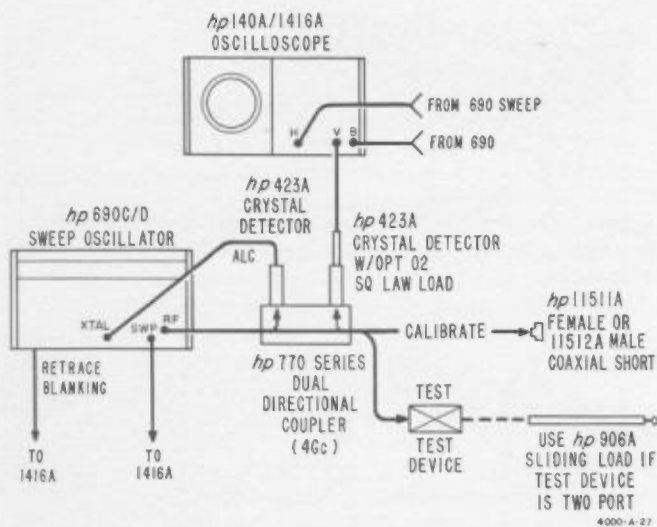

Figure 25. General system for swept reflection measurements in coax from 500 Mc to 8 Gc

MEASUREMENTS IN COAX - 500 MC TO 8 GC

A Coaxial Reflectometer, as shown in Figure 25, can be used for swept reflection measurements in the 500 Mc to 8 Gc region with the same advantages of oscilloscope readout, closed loop leveling, and straight-forward operation described for waveguide systems.

Incident and reflected power in the main line is sampled by an hp 770-series dual directional coupler and detected by 423A crystal detectors. Incident power to the test load is held constant by closed loop leveling the sweeper output with the detected incident signal. The reflected signal, detected by the 423A with matching square-law load (option 02), is read on the Model 140A/1416A Oscilloscope directly in DB Return Loss

or on a conventional oscilloscope using the SWR scales supplied with this Note.

To calibrate the system, a coaxial short is connected to the reflectometer output as shown in Figure 25 and a zero db return loss reference established on the oscilloscope. The short is then replaced by the unknown load and the amplitude decrease measured using the same procedure outlined under "Measurements in Waveguide" for waveguide reflection tests.

COAXIAL SYSTEM ACCURACY

The sources of error found in coax reflectometers are basically the same as those found in waveguide systems. The reflections of type N connectors, however, cause larger uncertainties in coax measurement so overall accuracy is not as high.

When measuring reflection coefficients of 0.5 or less overall accuracy of the coax reflectometer shown in Figure 25 can be expected to be about as follows:

500 Mc - 2 Gc,	$\pm(.01 + .07\rho_L + K\rho_L)$;
2 Gc - 4 Gc,	$\pm(.03 + .10\rho_L + K\rho_L)$;
4 Gc - 8 Gc,	$\pm(.06 + .14\rho_L + K\rho_L)$;

Where ρ_L is the load reflection coefficient and K is the decimal readout error of the indicating device.

Sources of error include effective source ρ , coupler directivity, imperfect short, detector deviation from square law, and frequency response of the coupler and detectors.

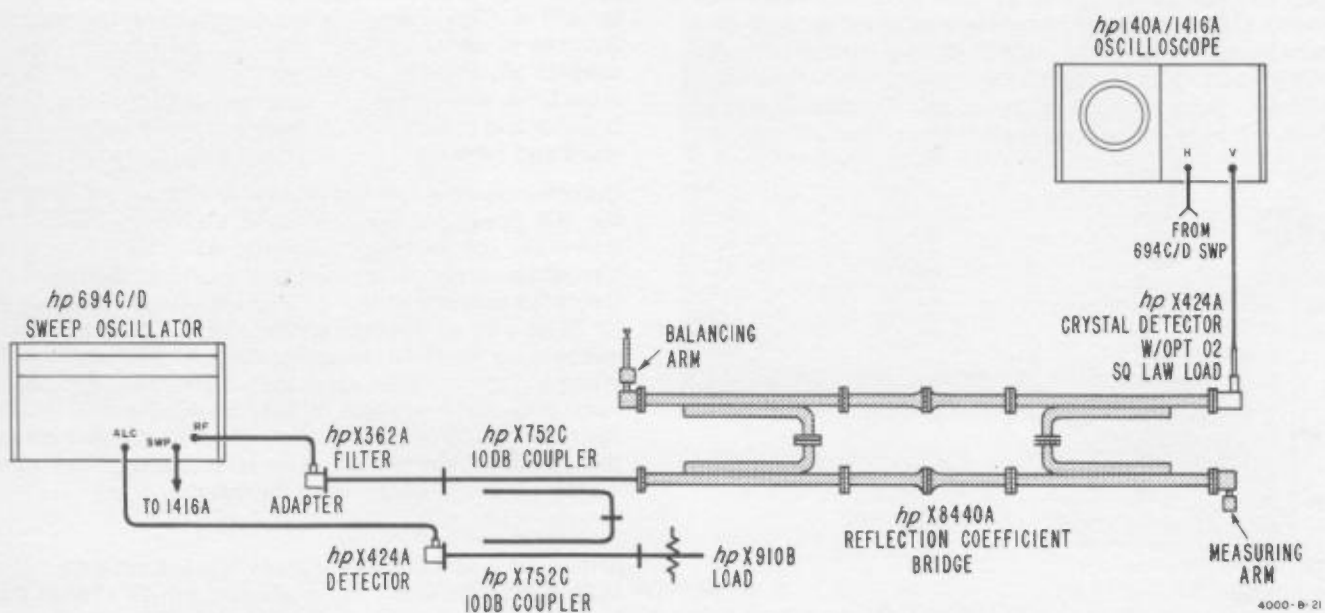

Figure 26. High accuracy swept reflection tests are now possible in coax from 8.2 to 12.4 Gc using hp X8440A Reflection Coefficient Bridge (shaded).

MEASUREMENTS IN COAX - 8.2 TO 12.4 GC

The type N connector commonly used in microwave is the primary factor limiting coax reflectometer usefulness much above 4 Gc. Closely related to the connector problem is the low directivity typically found in coax directional couplers designed for higher frequencies. As frequency increases, measurement uncertainties increase until, at X-band, the coax reflectometer has an equivalent residual ρ of 0.18 (SWR = 1.44:1). This is unacceptable for most applications. For accurate swept reflection tests in the 8.2 to 12.4 Gc band, the hp X8440A Reflection Coefficient Bridge and peripheral equipment shown in Figure 26 is recommended. The bridge (shaded portion) uses waveguide directional couplers for their high directivity and a waveguide-to-coax adapter to connect the test device. Waveguide-to-coax adapter reflection is effectively cancelled by a balancing scheme that reduces uncertainties considerably. Bridge accuracy in terms of reflection coefficient is $\pm(.03 + .16\rho^2)$, where ρ is the unknown load reflection coefficient. This is equivalent to a residual system SWR of 1.06:1 which is better than most X-band coax slotted lines.

Calibration and readout of the bridge is essentially the same as used with a coax reflectometer. The bridge measuring arm is alternately shorted and opened to establish a zero db return loss reference on the oscilloscope. The unknown load is then connected to the measuring arm and return loss measured by the amplitude decrease of the oscilloscope trace. Readout of the bridge can also be X-Y recorded if desired. HP Application Note 66 gives detailed theory and operation of the X8440A plus information for assembling and testing bridges in other waveguide bands where coax coupler directivity is low.

SPECIAL TECHNIQUES

Reflections in Long Waveguide Runs. Swept frequency techniques can be applied to locating and evaluating individual discontinuities in long waveguide runs such as used for antenna feed lines.

Figure 27 shows a simplified diagram of a system^{11,12} which operates on a chirp radar principle to locate reflections on the order of 1% with a resolution of 1 foot. The system has been used successfully on runs of 12 to 125 feet and more. Using the sweep rate and RF excursion giving best resolution of the individual waveguide reflections, the sweep oscillator energy is fed past a balanced mixer and down the waveguide run. Reflected energy from any discontinuity in the guide returns to the mixer and heterodynes with the incident wave which has changed frequency (because the source is sweeping) during the propagation interval between leaving the mixer and returning. The mixer output frequency is thus proportional to the time interval, and therefore the distance, to the discontinuity. The amplitude of the heterodyne output is proportional to the reflection coefficient of the particular discontinuity producing the response.

- 11 E. Aronoff, "Measurement of Discontinuities in Waveguides," IEEE Trans. Paper No. 63-53, January 27 - February 1, 1963.
- 12 W. A. Rawlinson et al, "A Swept Frequency Method of Locating Faults in Waveguide Aerial Feeders," Res. Report 20209, Post Office Research Station, Dollis Hill, London, N.W. 2, June 1959.

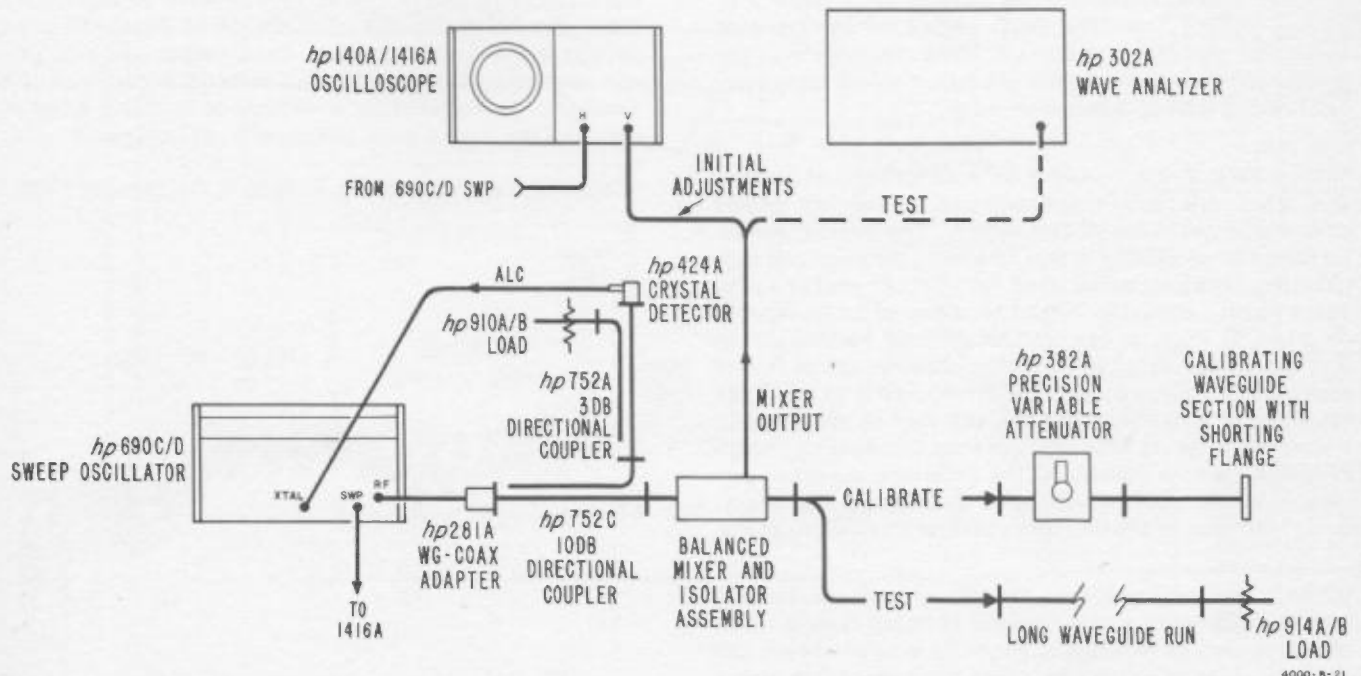

Figure 27. Simplified diagram of reflection measuring system for long waveguide sections

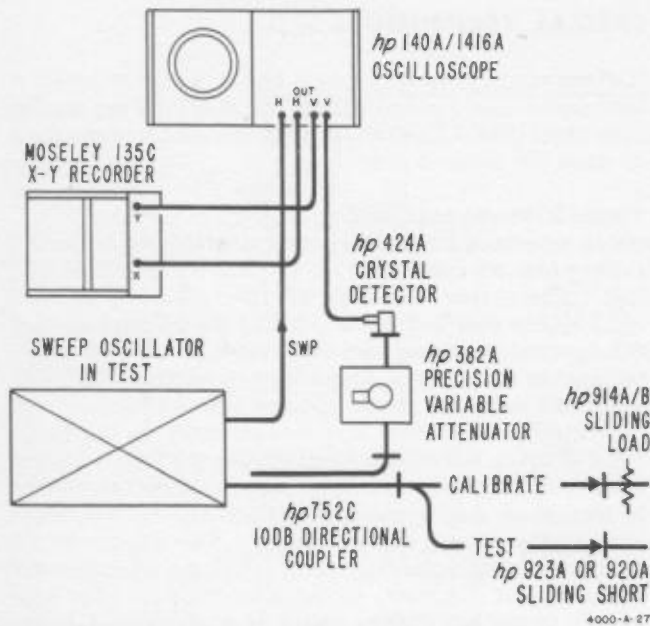

Figure 28. System for checking source SWR on sweep oscillator without leveling

The mixer output is first displayed on the oscilloscope to optimize system adjustments and then applied to the input of the hp 302A Wave Analyzer for calibration with a known length of guide. The 382A Variable Attenuator is used to calibrate the mixer output amplitude in return loss relative to the 100% reflection of the shorting flange. After calibration, the unknown guide is connected to the mixer output in place of the calibration section and the test is made. The frequencies and relative amplitudes read on the wave analyzer indicate the location and magnitude of the individual waveguide discontinuities.

In order to minimize errors caused by source frequency pulling, use the 690D series of PIN leveled sweepers wherever possible. This ensures that the leveling action does not shift the mixer output frequency calibration during a measurement.

Source SWR Tests. Output SWR on sweep oscillators and other microwave sources can be checked easily with equipment setup of Figure 28*. The system shown utilizes the oscillator in test to supply the required signals thus eliminating the need for another source in the same band. With the output terminated in the hp 910 or 914A/B load, a calibration grid is plotted on the X-Y Recorder using 382A attenuator settings of return loss corresponding to specific source SWR values. After plotting a calibration grid, the load is replaced by a waveguide short which reflects the incident wave back to the source. A portion of the reflected signal is reflected by the source mismatch up through the directional coupler to the detector, adding in random phase

* Note: In the setup shown, the sweeper is not leveled because the basic source match is being tested. The effectiveness of leveling to improve source match can also be checked using the same procedure but with a leveling coupler/detector loop between the sweeper and waveguide components shown.

with the incident signal. When using the 920A short, single sweeps are triggered and recorded for several small incremental changes in the short position over $\lambda/4$ at the lowest frequency, taking into account various phases of source reflections. When the hp 923A short is used, only one test sweep is required while rapidly phasing the short. The envelope of the resulting plot represents source SWR as a function of frequency. Attenuator settings for the calibration grid are determined from the following equations:¹³

$$-DB_1 = 20 \log_{10} 2(1 - \rho_g) \quad (4)$$

$$-DB_2 = 20 \log_{10} 2(1 + \rho_g) \quad (5)$$

where ρ_g = simulated generator reflection coefficient.

Example:

A sweep oscillator with a maximum specified output SWR of 2:1 is connected for test as shown in Figure 28. By the relationship of equation 2 given earlier, a 2:1 SWR is approximately equal to a ρ of 0.33. Substituting for ρ_g in equations 4 and 5 and rounding off to the nearest tenth:

$$-DB_1 = 20 \log_{10} 2(1 - 0.33) = 2.5$$

$$-DB_2 = 20 \log_{10} 2(1 + 0.33) = 8.5$$

Using either equation 4 or 5, the attenuator setting corresponding to a source SWR of unity is found to be 6 db. Grid lines are plotted for the three attenuator settings and the attenuator returned to -6 db. The final plots are then made using the movable short, resulting in a record similar to Figure 29. Since the envelope of the plot remains inside the 2:1 SWR limits, the sweeper output system meets specifications.

This same general technique can also be applied to check output SWR of other broadband sources such as the hp 938A and 940A Harmonic Doublers. In this case the doubler in test is driven by a leveled sweep oscillator and the waveguide components of Figure 28 connected to the doubler output. Coax output systems are not as readily tested with this method because of the ambiguity introduced by a waveguide to coax adapter between the output port and directional coupler.

¹³ HP Journal, Vol. 12, No. 4, Page 5, (December 1960).

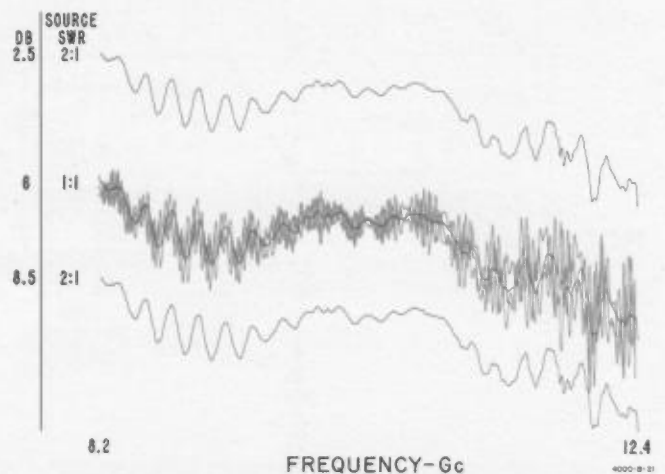

Figure 29. Swept SWR plot of signal source

POWER

GENERAL

Power measurement is usually associated with fixed frequency techniques rather than swept, though modern thermistor mounts will operate over broad bands without tuning. Many applications, of course, require fixed frequency power measurement because of the device in test, (e.g., checking a signal generator or transmitter output). There are, however, a number of useful swept-power techniques that can be used to great advantage. For example, full range tests of TWT amplifier gain, antenna frequency response, and thermistor mount efficiency can be readily performed using appropriate sweepers and power meter leveling arrangements.

THERMISTOR MOUNT EFFICIENCY TESTING

A variation of power meter leveling is shown in Figure 30 where a thermistor mount is being tested for effective efficiency on a swept frequency basis. Effective efficiency (η_e) of a thermistor mount is the ratio: $\eta_e = \frac{P_{dc \text{ substituted}}}{P_{\mu \text{ wave absorbed}}}$, where $P_{dc \text{ substituted}}$ is the

dc (or audio) power substituted in the thermistor element and $P_{\mu \text{ wave absorbed}}$ is the total microwave power dissipated in the mount.

Incident and reflected power at the test mount are sampled by two directional couplers feeding a pair of temperature-compensated thermistor mounts and hp 431B power meters. The recorder output of each meter is connected to the input of a differential leveling amplifier in the Efficiency Calibrator where a feedback voltage proportional to net forward

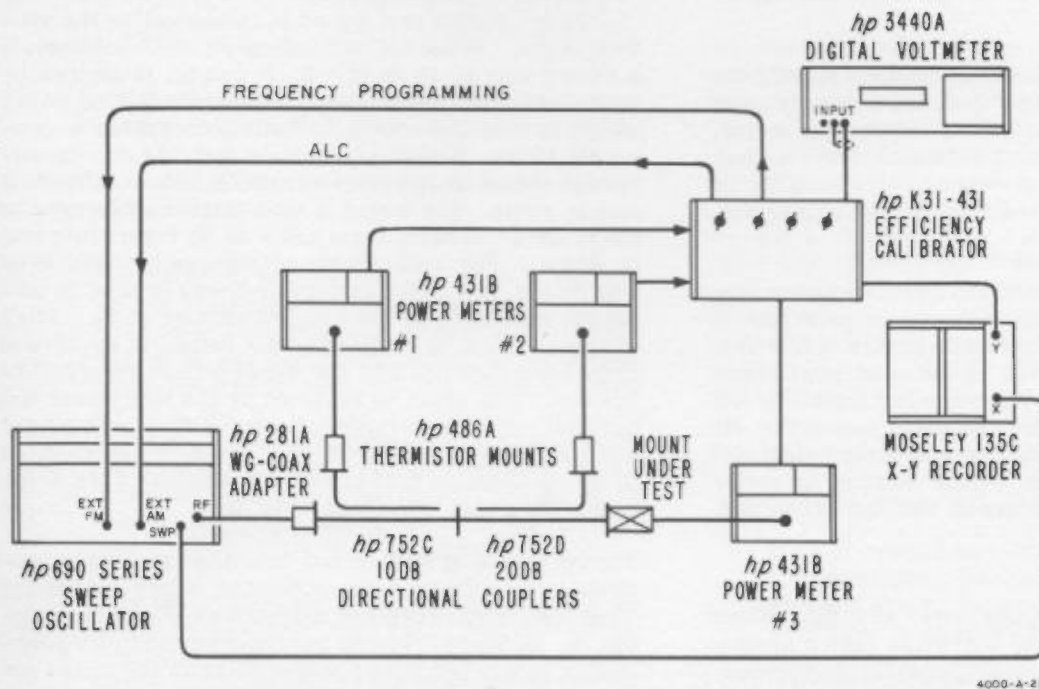
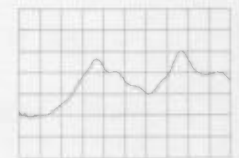

Figure 30. Thermistor Mount Efficiency Calibration System



ATTENUATION



IMPEDANCE
REFLECTION
COEFFICIENT



POWER



FREQUENCY

TWT AMPLIFIER GAIN TEST

Figure 31 shows a Traveling Wave Tube amplifier being tested for gain throughout its full operating band using a sweep oscillator with power meter leveling. Power at the TWT input is monitored and held constant by power meter #1 while meter #2 and the X-Y Recorder indicate gain versus frequency at the TWT output. The zero-carryover feature of the 431B Power Meter allows use of the range switch to calibrate the X-Y Recorder span in db of gain.

The procedure is as follows:

- With the sweeper LINE switch in STANDBY, null and zero the power meters following the procedure outlined in the 431B Operating and Service Manual.
- Set #1 and #2 meter RANGE to 1 mw and 0.1 mw respectively.
- Connect the 10 db directional coupler to the 20 db directional coupler input as shown in Figure 31 for the CALIBRATE configuration, and turn the 690 LINE to RF.
- With the 690 slowly sweeping the full frequency range of the TWT, adjust the sweeper POWER LEVEL and ALC GAIN for a leveled indication of 0.05 mw on meter #2.
- Set up the X-Y Recorder for on-scale operation and negative vertical input, positioning the pen near the bottom of the paper. Set 690 C/D SWEEP SELECTOR to TRIGGER and plot a 30 db gain reference trace on the recorder by pushing the MANUAL trigger button on the 690.
- By setting meter #2 to full scale (3 db increase) with its zero control, a second calibration line of 33 db can be plotted. Be sure to return the zero control of meter #2 to half scale after the plot is made.
- Set meter #1 and #2 RANGE to 0.1 mw and 10 mw respectively. Because of zero-carryover, the leveled power at the 10 db coupler will drop precisely 10 db to maintain the mid-scale reading on meter #1. Calibration sensitivity of the X-Y recorder readout will drop precisely 20 db by the up-ranging of meter #2. Thus, the combined effect of the 20 db sensitivity decrease and 10 db power drop equals the anticipated 30 db gain of the TWT amplifier in test.
- Now insert the TWT amplifier into the setup as shown in Figure 31 for "TEST" and turn up the amplifier GAIN. (Do not exceed 1 watt output.) Again manually trigger the sweeper and record the gain versus frequency of the amplifier. If the amplifier exceeds 30 db of gain, the RECORDER TRACE will remain above the 30-db calibration line previously drawn. Figure 32 shows a swept TWT gain test from 7 to 10 Gc.

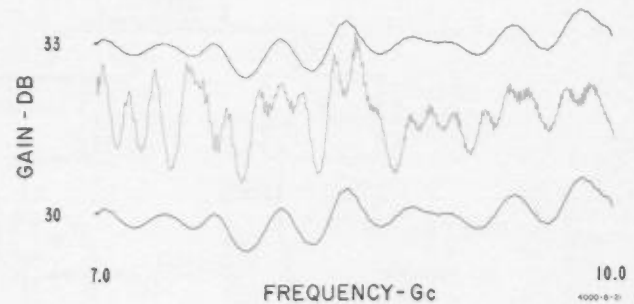

Figure 32. X-Y Plot of TWT Gain Test

HIGH RESOLUTION ATTENUATION TESTS

The dc substitution feature on the hp 431B Power Meter, plus its leveling capability can be combined for high resolution swept attenuation tests using the setup of Figure 33. RF power from the sweeper is controlled by the leveling feedback derived from the total power sensed in the thermistor mount of meter #1. This power can be RF, dc, or a combination of the two producing a constant reading on the 431B. When a dc power increase is applied to the thermistor from the hp 8402A Power Meter Calibrator, after a leveled RF power has first been established, a corresponding decrease in RF output power occurs. This correlation of RF power decrease with dc power increase provides a high resolution readout calibration that can be used with an X-Y Recorder for attenuation measurements to about 10 db.

Figure 34 shows the results of two attenuation tests made with the system described. The 10 db test in (a) clearly shows the 1 db variation of a flap attenuator over a large portion of an 8-1/2 x 11" X-Y record. The low loss test in (b) demonstrates the ability of the system to detect even sharp variations in attenuation. For this test, an hp X532B Absorption Wavemeter was inserted as the test device and set to 10.0 Gc. Sweep time was 30 seconds. While the readout reaction time was not fast enough to measure the power dip accurately at wavemeter resonance, the test did reveal an extremely narrow point (approximately 2 Mc wide) that could be retraced more slowly with the 690C/D MANUAL SWEEP. Another procedure would be to narrow the total sweep over the area of resonance allowing full reaction to the true attenuation.

System calibration and operation is as follows:

- With dc substitution power (hp 8402A) off, a leveled RF power indication of 0.5 mw is established on #1 431B Power Meter. The H01-8401A Leveler Amplifier is adjusted for maximum feedback loop gain without oscillation as frequency is swept through the band.
- With the equipment connected in the CALIBRATE configuration, #2 431B Power Meter and the X-Y Recorder range is set for on-scale operation. The 0.5 mw reading on meter #1 is checked and

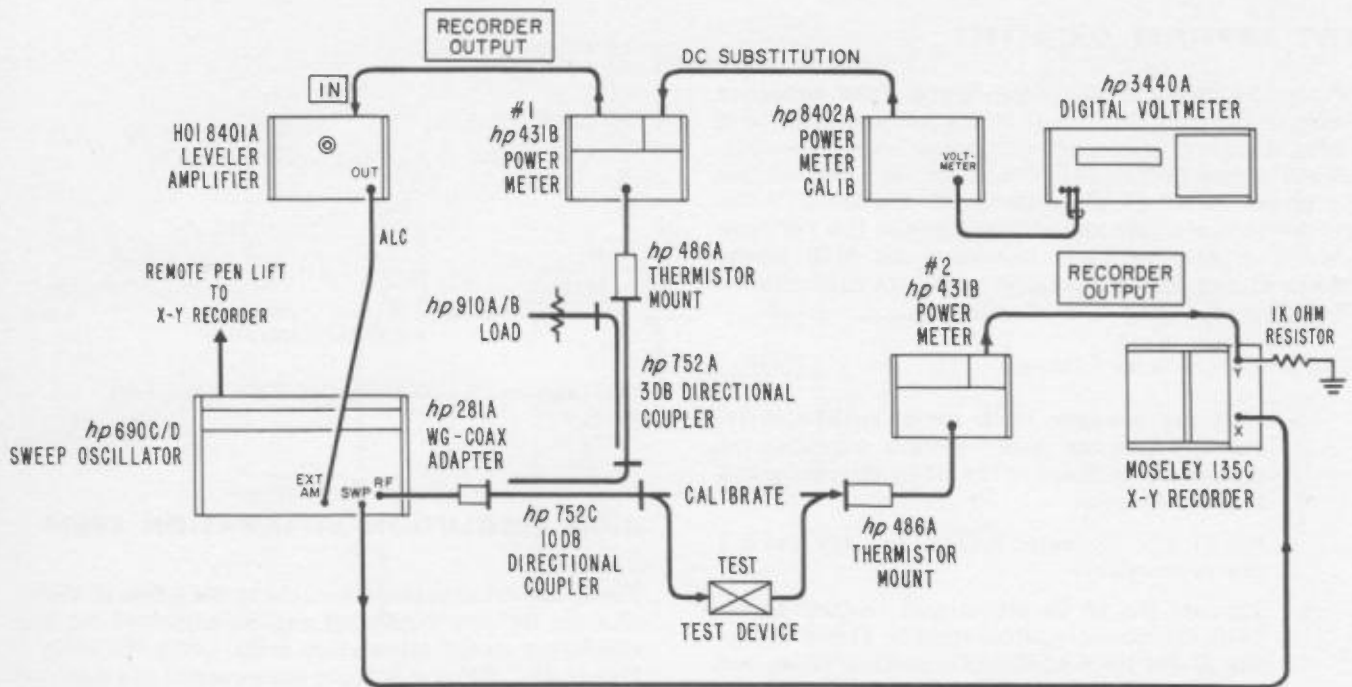

Figure 33. High resolution swept attenuation test setup using dc substitution provision in hp 431B Power Meter.

readjusted if necessary, and a zero db reference line is plotted on the X-Y Recorder. Additional reference lines are plotted near the anticipated values of attenuation to be measured by applying accurately known values of dc power to #1 power meter with the 8402A Power Meter Calibrator. Table 3 lists dc voltage readings indicated by the hp 3440A DVM for corresponding values of attenuation simulated (from 0.5 mw reference on meter #1).

- The dc substitution from the 8402A is then turned off and the test device inserted into the system and swept.

In Figure 34(a) the zero db reference was offset using the recorder ZERO in order to obtain best resolution. Note overall flatness and minimal fine grain variations in the calibration grid allowing easy readout of test results. The directional couplers in the super-leveling array were not specially matched for this test.

DVM readings for attenuation calibration with other than 0.5 mw reference on meter #1 may be calculated from the following equations:

1. For hp 8402A ranges of 0.01 to 1 mw;

$$E_{dvm} = 63.2 \sqrt{\frac{P_1 \left[1 - \log^{-1} \left(\frac{-db}{10} \right) \right]}{R_m}} \quad (6)$$

2. For hp 8402A ranges of 3 and 10 mw;

$$E_{dvm} = 20 \sqrt{\frac{P_1 \left[1 - \log^{-1} \left(\frac{-db}{10} \right) \right]}{R_m}} \quad (7)$$

Where: E_{dvm} = Digital voltmeter reading in volts

-db = Attenuation simulated

P_1 = Reference power level (mw) read on meter #1

R_m = Meter #1 thermistor mount resistance in ohms, e.g., 100 or 200 ohms

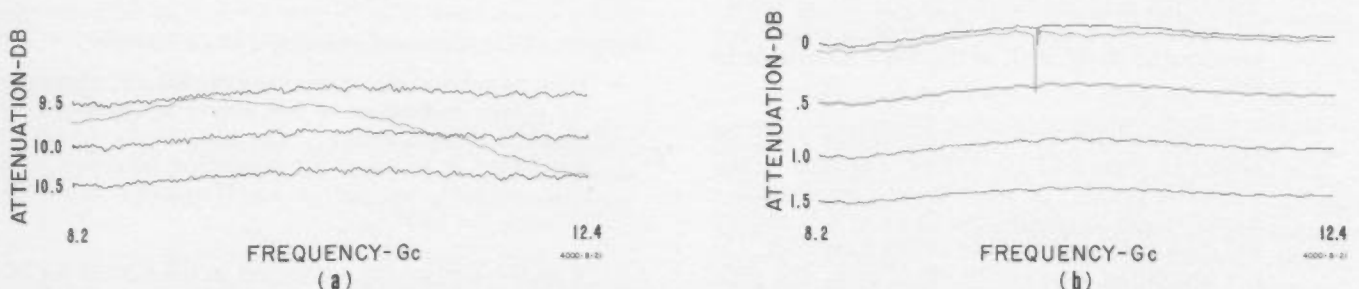

Figure 34. (a) High resolution X-Y plot of hp 375A Attenuator set at 10 db. (b) High resolution X-Y plot of hp 532B Wavemeter set at 10.0 Gc showing system reaction to sharp "holes".

TABLE 3

DC output voltage of 8402A versus RF attenuation from 0.5 mw reference. Use with system shown in Figure 33 for accurately calibrating X-Y Recorder span over desired attenuation range.

100 Ohm Thermistor Mount				200 Ohm Thermistor Mount			
Attenuation DB	DVM Volts	Attenuation DB (cont'd)	DVM Volts (cont'd)	Attenuation DB	DVM Volts	Attenuation DB (cont'd)	DVM Volts (cont'd)
0	0	5.5	3.790	0	0	5.5	2.680
0.5	1.475	6.0	3.869	0.5	1.043	6.0	2.736
1.0	2.028	6.5	3.939	1.0	1.434	6.5	2.786
1.5	2.417	7.0	4.001	1.5	1.709	7.0	2.829
2.0	2.716	7.5	4.055	2.0	1.921	7.5	2.867
2.5	2.958	8.0	4.102	2.5	2.092	8.0	2.900
3.0	3.158	8.5	4.144	3.0	2.233	8.5	2.930
3.5	3.326	9.0	4.180	3.5	2.352	9.0	2.956
4.0	3.469	9.5	4.213	4.0	2.453	9.5	2.980
4.5	3.592	10.0	4.242	4.5	2.540	10.0	3.000
5.0	3.698	10.5	4.267	5.0	2.614	10.5	3.017

FREQUENCY

GENERAL

Frequency measurements fall into two general classifications, active and passive. Active measurements are those in which the frequency of an active source such as a signal generator, transmitter, or local oscillator is being checked. The hp 5245L/5254A Electronic Counter measures active sources directly to frequencies well into the microwave region with accuracies of a few parts in 10^8 . Frequencies above the counter range may be measured indirectly using the hp 540B Transfer Oscillator or 2590A Microwave Frequency Converter, in conjunction with the 5245L/5253B Counter. The counter/transfer oscillator has become the mainstay of microwave frequency measurements requiring high accuracy.

In certain applications where accuracy requirements are not as critical, the simplicity and low cost of passive frequency measurements may be enjoyed. Cavity wavemeters such as the hp 532, 536A, and 537A are two port passive devices that absorb part of the input power in a tunable resonant cavity. When the cavity is tuned to resonate at the input frequency, a dip occurs in the output power level which is detected and indicated by a meter or oscilloscope. Frequency is then read directly on a calibrated dial driven by the cavity tuning mechanism. The accuracy of cavity wavemeters depends upon the cavity Q, tuning dial calibration, backlash and the effects of temperature and humidity variation. The hp waveguide and coax frequency meters, 532 series, 536A and 537A, achieve accuracies of a few parts in 10^4 .

Swept techniques with a counter/transfer oscillator reference, can be used to great advantage in calibrating passive devices such as the wavemeters described.

WAVEMETER CALIBRATION

A system for calibrating several wavemeters with great speed is shown in Figure 35. Using the ΔF sweep mode, the 690C/D is set for a leveled, rapidly sweeping output across a small segment of the wavemeter's band with the main power being fed through the wavemeters to a crystal detector. The detected wavemeter dip is fed to the vertical input of an oscilloscope and subsequently displayed on the CRT. This constitutes the measurement channel of the system. The reference channel is formed by coupling a portion of the sweeper output to the input of the 540B Transfer Oscillator. Harmonics of the transfer oscillator mix with the sweeping input signal producing heterodyne "birdies" at intervals equal to the transfer oscillator fundamental frequency. For example, if the transfer oscillator frequency is 200 Mc, and the input frequency is sweeping from 8.2 to 12.4 Gc, birdies will appear every 200 Mc throughout the swept band. The horizontal input of the oscilloscope is driven by the dc sweep voltage from the 690C/D.

The frequency interval of the birdies may be precisely set using the 5245L counter to monitor the transfer oscillator fundamental frequency. The birdies are fed through a BNC Tee connector to the oscilloscope vertical input and superimposed with the wavemeter dip. Now each wavemeter may be adjusted in turn for coincidence of the dip and reference birdies, noting the accuracy of dial calibration at each point. Frequency resolution of the display may be adjusted with the sweeper's STOP/ ΔF control which determines the sweep excursion. The center frequency of the sweep is set by the START/CW control when operating in the ΔF sweep mode. The START/CW control is used to progressively tune across the wavemeter band, stopping at each birdie and superimposing the wavemeter dip. Figure 36(a) shows a wide sweep displaying several birdies for rapid initial tuning of the wavemeter dip. Figure 36(b) shows the resulting display on a narrow sweep when the wavemeter dip and reference birdie coincide.

In most cases the wavemeter dial calibration will be accurate enough so that the absolute frequency of a birdie need not be measured, only its interval as provided by the display. When positive identification of birdie frequency is desired, the transfer oscillator is alternately set to adjacent zero beats with the 690C/D STOP/ ΔF set near zero. The counter readings at each beat are then used for unique determination of the birdie frequency. All other birdie frequencies are then easily determined by adding (or subtracting) the frequency interval to the birdie measured. Since frequency increases from left to right on the oscilloscope display, the easiest method is to measure the absolute frequency of



ATTENUATION

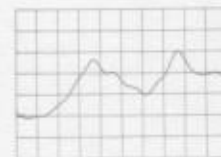

IMPEDANCE
REFLECTION
COEFFICIENT



POWER



FREQUENCY

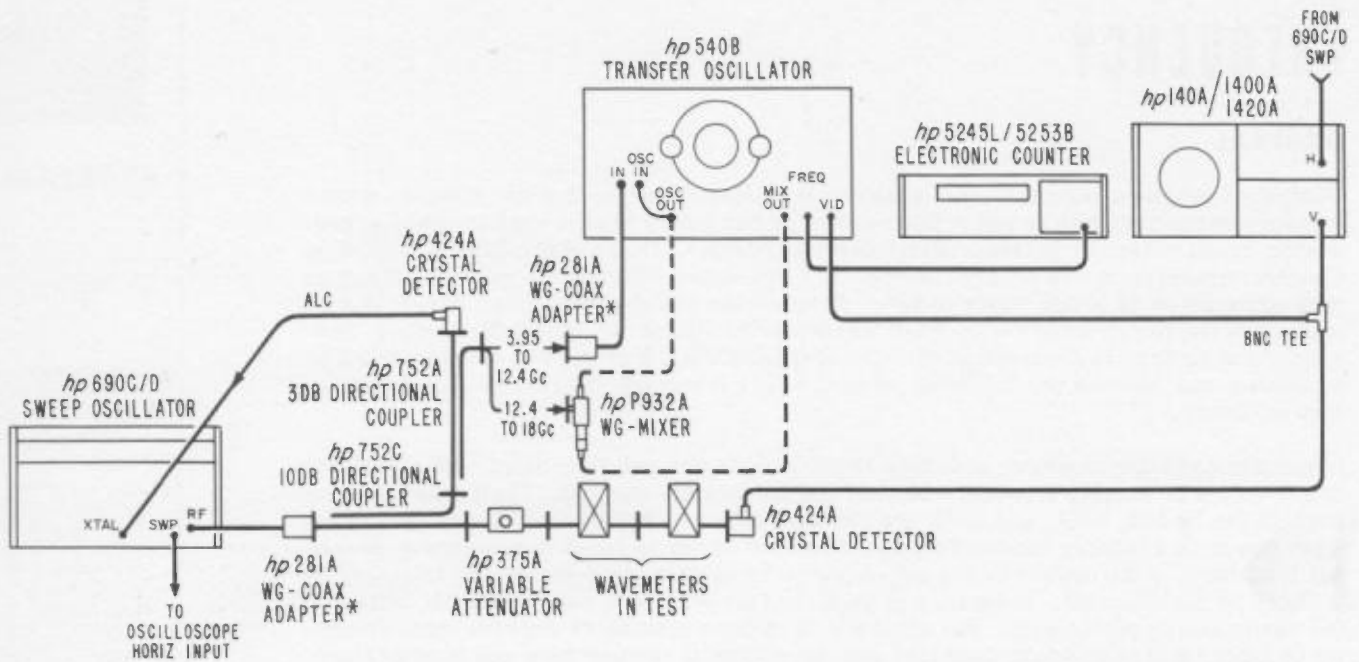

* WG-COAX ADAPTER NOT REQUIRED FOR 12.4-18Gc BAND

4000-B-21

Figure 35. Swept system for rapid frequency testing passive devices to 18.0 Gc. Internal mixer in 540B is used to 12.4 Gc. HP P932A Waveguide Mixer operates external to 540B to cover 12.4 to 18.0 Gc range.

the birdie closest to the left edge of the display and simply add the interval frequency for each birdie progressively to the right. To do this proceed as follows:

- Carefully set the transfer oscillator fundamental frequency to 200 Mc as read on the counter.
- Observing the oscilloscope display, reduce the 690C/D sweep width with the STOP/ Δ F control until the zero beat is about 1 cm wide. Re-adjust the START/CW control as required to position the lowest frequency birdie in the center of the display.

- Note the transfer oscillator fundamental frequency as read on the counter.
- Carefully adjust the transfer oscillator frequency to the adjacent zero beat, placing it exactly at center screen on the oscilloscope, and again note the counter reading.
- Calculate the harmonic number (N) from the equation

$$N_1 = \frac{F_2}{F_1 - F_2}, \quad (8)$$

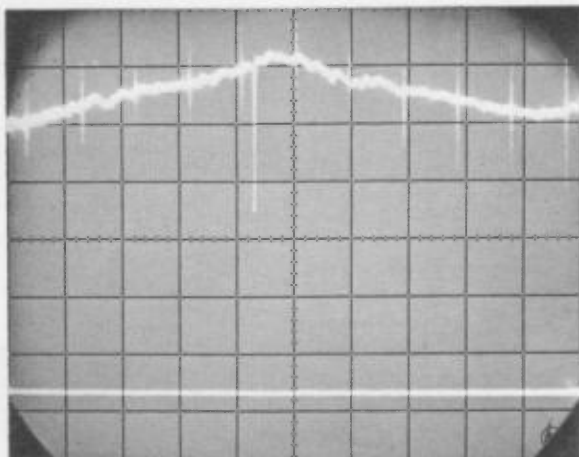

(a)



(b)

4000-A-27

Figure 36. (a) CRT photo of wavemeter dip and several birdies for rapid adjustment. (b) CRT photo of wavemeter dip and single birdie for high resolution.

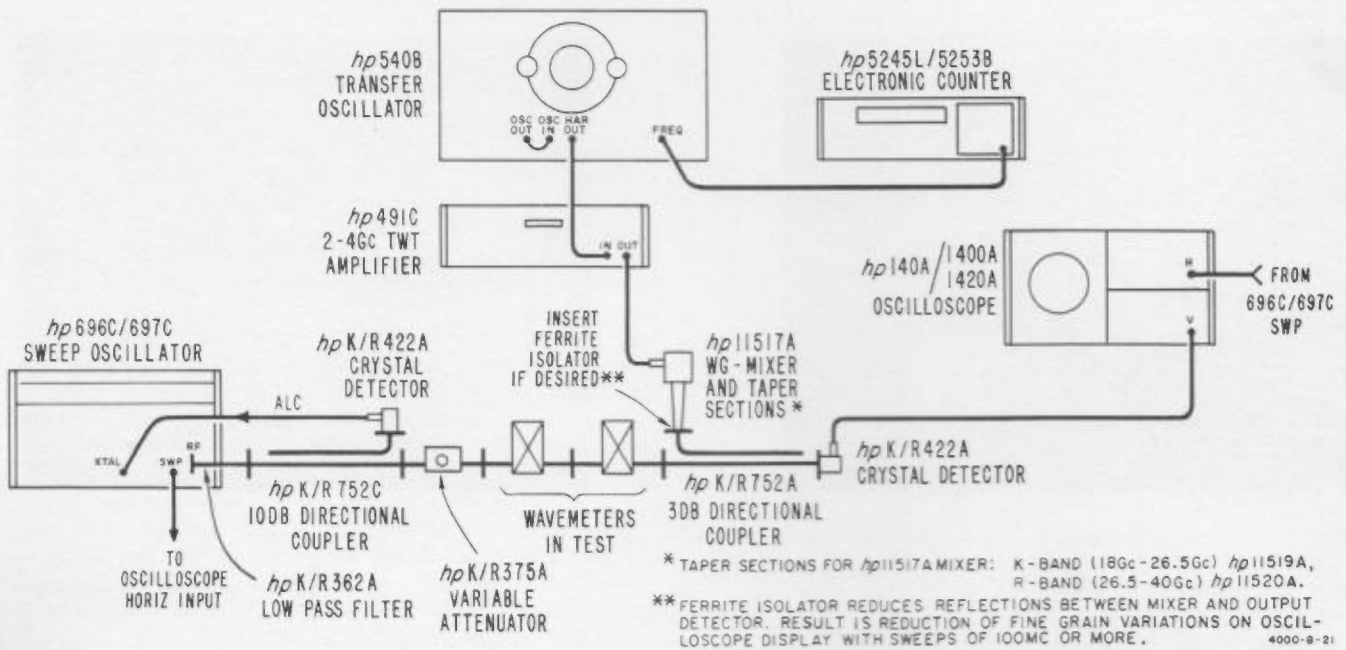

Figure 37. Swept system for passive frequency measurements from 18.0 to 26.5 Gc (K-band) and 26.5 to 40.0 Gc (R-band). TWT Amplifier boosts harmonic output from hp 540B in 2 - 4 Gc region. External harmonic generator then produces K or R-band harmonics for mixing with sweeper output.

where N_1 is always a whole number and F_1 is the larger of the two fundamental frequencies measured. The birdie frequency then is $F_x = N_1 F_1$. (9)

Example: $F_1 = 200 \text{ Mc}$

$F_2 = 195.238 \text{ Mc}$

$$N_1 = \frac{195.238}{(200 - 195.238)} = 41$$

$F_x = (41) \times 200 \text{ Mc} = 8.2 \text{ Gc}$

Between 12.4 and 18.0 Gc, the hp P932A Waveguide Mixer is used external to the transfer oscillator as shown in Figure 35 by the dashed line connections. After connecting the external mixer, the measuring procedure is identical to that described for frequencies below 12.4 Gc.

From 18.0 to 40.0 Gc the system configuration is altered and an amplifier added to boost the higher harmonic output of the transfer oscillator.

In the test setup of Figure 37, the K or R-Band sweep oscillator power is leveled and fed through a variable attenuator to the wavemeters in test. The attenuator is set to about 20 db to reduce source power and pad effects of the wavemeter reaction at resonance. The wavemeter dip is detected by the hp 422A detector and displayed on the oscilloscope. Vertical sensitivity of the oscilloscope is set to about $200 \mu\text{v/cm}$ with a bandwidth of 400 kc. Harmonics generated by the 540B Transfer Oscillator are amplified in the 2-4 Gc region by the TWT amplifier and fed to the hp 11517A Waveguide Mixer at a level of about 250 mw.

Before connecting the TWT output to the mixer, the power level should be adjusted using the TWT gain control. An hp 431B/478A Power Meter and 20 db coaxial

attenuator connected to the TWT output allows convenient adjustment to be made for a reading of 2.5 mw (+ 20 db correction for pad = 250 mw). The TWT output is now connected to the coax input of the mixer resulting in harmonic generation in the 18 to 40 GC region. Harmonics are at frequency intervals equal to the transfer oscillator fundamental frequency as measured by the counter. The harmonics are combined with the wavemeter dip and detected by the 422A Detector with subsequent display on the oscilloscope. Optimum birdie amplitude with relation to the wavemeter dip is affected by the oscilloscope vertical sensitivity and bandwidth, 375A attenuation setting, and TWT gain. Slight readjustment of TWT gain may be required to peak the birdie amplitude after initial adjustments have been made.

Note in Figure 37, that a ferrite isolator between the harmonic mixer and 3 db coupler is optional. The isolators will reduce fine grain power variations in the display caused by mixer reflections as shown in Figure 38. The isolator does not increase accuracy but may be desirable from a readout convenience standpoint.

SYSTEM ACCURACY

The overall accuracy of the measuring system just described is determined primarily by 1) the accuracy of the birdie markers and 2) the accuracy in comparing the wavemeter dip to the birdies.

Birdie accuracy depends on the transfer oscillator stability and the counter accuracy. Comparison accuracy is determined by the wavemeter Q and overall system resolution.

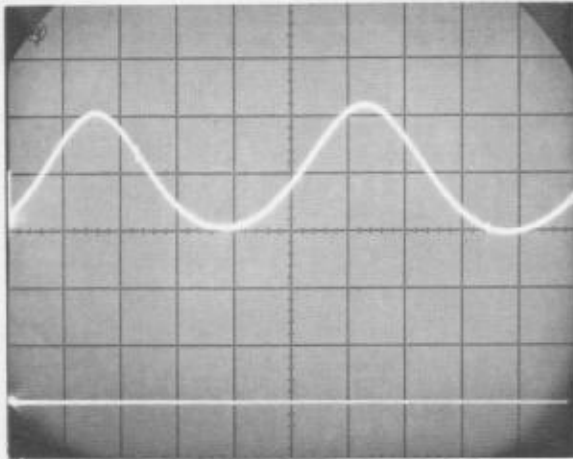

(a)

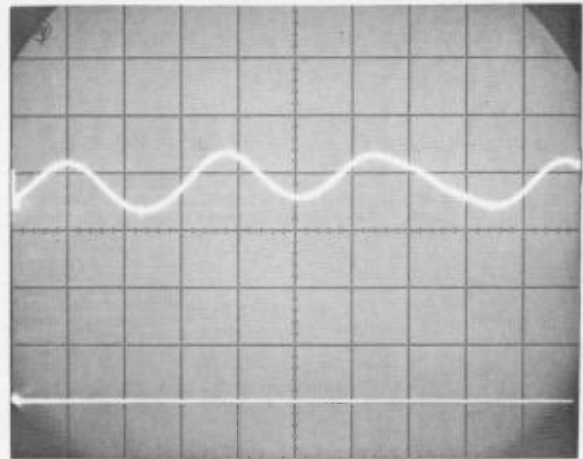

(b)

4000-A-27

Figure 38. (a) Power variations in R-band wavemeter calibration setup without ferrite isolator between harmonic mixer hp 11517A and 3-db coupler. (b) Power variations with ferrite isolator. Vertical sensitivity for both photos is 2 mv/cm, birdie interval at 200 Mc.

The various sources of error for a typical system in K-Band, using the equipment and procedure previously described, are as follows:

Birdie Accuracy*: HP 5245L Counter (± 1 count ambiguity \pm time base stability) = $(\pm 1/10^8 \pm 3/10^9) = 13/10^9$.

HP 540 B transfer oscillator stability = $2/10^7$ short term.

Comparison Accuracy: With a 40 Mc sweep (one birdie displayed) and a wavemeter Q of approximately 4000, resolution is about 1 Mc or $4/10^5$.

*After equipment reaches thermal equilibrium.

Note that resolution is the primary limiting factor, so the usual procedure is to initially tune the wavemeter dip to the birdie with a convenient wide sweep, then make the final adjustment on a smaller sweep such as 40 Mc in K-Band. This provides the convenience and resolution necessary for checking the wavemeter accuracy.

CAVITY Q MEASUREMENTS

Cavity Q is defined as the ratio:

$$Q = \frac{f_0}{f_1 - f_2}, \tag{10}$$

where f_0 = resonant frequency of the cavity $\approx \frac{f_1 + f_2}{2}$.

f_1 & f_2 = frequencies above and below resonance, respectively, corresponding to the half power points of the cavity response.

Using the relationship of equation 10, cavity Q may easily be measured with the system shown in Figure 35 or 37. The birdie in Figure 36(b) may be alternately set to the half amplitude points* on the dip by carefully tuning the transfer oscillator frequency. Cavity Q is then calculated directly from the two transfer oscillator fundamental frequencies as read on the counter. There is no need to determine the harmonic number and actual microwave frequencies.

$$Q = \frac{f_1' + f_2'}{2(f_1' - f_2')} \tag{11}$$

Where f_1' and f_2' = transfer oscillator fundamental frequencies at cavity half power points.

* Half amplitude on the display corresponds to half power when the detector is operating in square law.

NOISE FIGURE

Swept frequency noise figure analysis may be made on broadband microwave devices such as traveling wave tube amplifiers by providing a sweeping receiver and using an automatic noise figure meter. Figures 39 and 40 show the system diagram and a swept frequency plot of noise figure for traveling wave tube amplifiers at specific electrode potentials. The IF amplifier shown has a bandwidth of 1 Mc, and since the sweeping receiver has full image response, the noise figure meter responds to the average of two 1 Mc windows spaced ± 30 Mc from the local oscillator frequency. This is normally adequate for measurements where the swept frequency plot is not changing rapidly.

For proper accuracy, it is necessary to make a calibrating run on the receiver itself to assure that its noise contribution is negligible. In Figure 39 shown, the receiver noise figure remained below 15 db across the band, and thus adds no error to the TWT contribution of approximately 25 - 30 db.

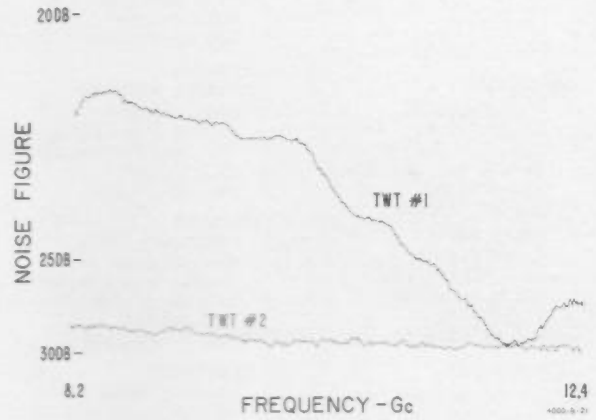
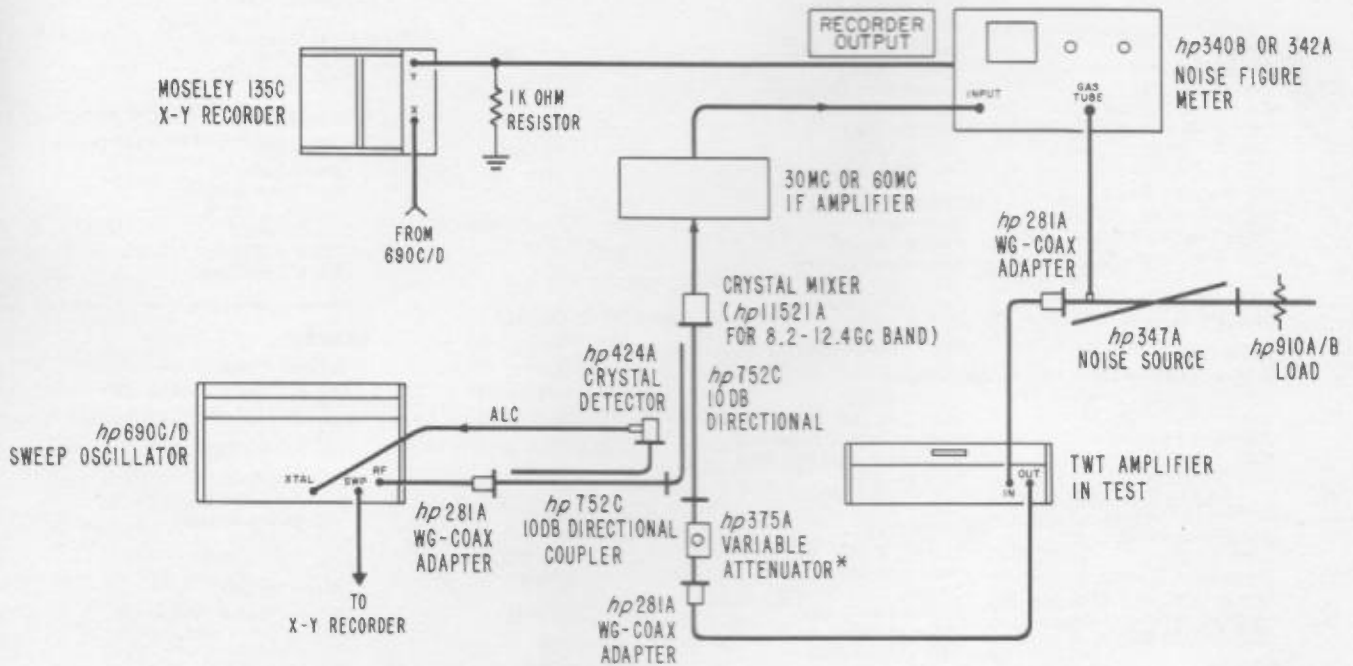

Figure 40. X-Y plot of noise figure for two TWT amplifiers measured with system shown in Figure 39.



* 375 VARIABLE ATTENUATOR OPTIONAL

NOTE: SWEEPER LEVELING AND TWT OUTPUT SIGNAL MIXING CAN BE ACCOMPLISHED WITH COAX COMPONENTS BELOW X-BAND.

4000-8-21

Figure 39. The noise figure for such broadband microwave devices as traveling wave tube amplifiers can be analyzed with system shown above. Receiver noise figure is negligible compared to the TWT contri^o

HP SALES AND SERVICE OFFICES IN THE U.S. AND CANADA

ALABAMA

Huntsville, 35801
Hewlett-Packard
Southern Sales Division
Holiday Office Ctr., Suite 18
(205) 881-4591
TWX: 510-579-2204

ARIZONA

Scottsdale, 85251
Hewlett-Packard
Neely Sales Division
3009 No. Scottsdale Rd.
(602) 945-7601
TWX: 602-949-0111

Tucson, 85716
Hewlett-Packard
Neely Sales Division
232 So. Tucson Blvd.
(602) 623-2564
TWX: 602-922-2759

CALIFORNIA

Los Angeles Area
Hewlett-Packard
Neely Sales Division
3939 Lankershim Blvd.
North Hollywood 91604
(213) 877-1282 and 766-3811
TWX: 910-499-2170

Sacramento, 95821
Hewlett-Packard
Neely Sales Division
2591 Carlsbad Ave.
(916) 482-1463
TWX: 916-444-8683

San Diego, 92106
Hewlett-Packard
Neely Sales Division
1055 Shafter Street
(714) 223-8103
TWX: 714-276-4263

San Francisco Area
Hewlett-Packard
Neely Sales Division
1101 Embarcadero Rd.
Palo Alto 94303
(415) 327-6500
TWX: 910-373-1280

COLORADO

Englewood, 80110
Hewlett-Packard
Neely Sales Division
7965 East Prentice
(303) 771-3455
TWX: 303-771-3056

CONNECTICUT

Middletown, 06458
Hewlett-Packard
Yewell Sales Division
589 Saybrook Rd.
(203) 346-6611
TWX: 710-428-2036

FLORIDA

Miami, 33125
Hewlett-Packard
Florida Sales Division
2907 Northwest 7th St.
(305) 635-6461

Orlando, 32803
Hewlett-Packard
Florida Sales Division
621 Commonwealth Ave.
(305) 425-5541
TWX: 305-275-1234

St. Petersburg, 33708
Hewlett-Packard
Florida Sales Division
410-150th Ave., Madeira Beach
(813) 391-0211
TWX: 813-391-0666

GEORGIA

Atlanta, 30305
Hewlett-Packard
Southern Sales Division
3110 Maple Drive, N. E.
(404) 233-1141
TWX: 810-751-3283

ILLINOIS

Chicago, 60645
Hewlett-Packard
Crossley Sales Division
2501 West Peterson Ave.
(312) 275-1600
TWX: 910-221-0277

INDIANA

Indianapolis, 46205
Hewlett-Packard
Crossley Sales Division
3919 Meadows Dr.
(317) 546-4891
TWX: 317-635-4300

KENTUCKY

Louisville, 40218
Hewlett-Packard
Southern Sales Division
Suite 4, 3411 Bardstown Rd.
(502) 459-4140
TWX: 810-535-3128

MARYLAND

Baltimore, 21207
Hewlett-Packard
Horman Sales Division
6660 Security Blvd.
(301) 944-5400

Washington, D. C. Area
Hewlett-Packard
Horman Sales Division
941 Rollins Avenue
Rockville 20852
(301) 427-7560
TWX: 710-828-9684

MASSACHUSETTS

Boston Area
Hewlett-Packard
Yewell Sales Division
Middlesex Turnpike
Burlington 01804
(617) 272-9000
TWX: 710-332-0382

MICHIGAN

Detroit, 48235
Hewlett-Packard
Crossley Sales Division
14425 West Eight Mile Road
(313) 342-5700
TWX: 313-342-0702

MINNESOTA

St. Paul, 55114
Hewlett-Packard
Crossley Sales Division
842 Raymond Avenue
(612) 646-7881
TWX: 910-563-3734

MISSOURI

Kansas City, 64131
Harris-Hanson Company
7916 Paseo Street
(816) 444-9494
TWX: 816-556-2423

St. Louis, 63144
Harris-Hanson Company
2814 South Brentwood Blvd.
(314) 647-4350
TWX: 314-962-3933

NEW JERSEY

Asbury Park Area
Hewlett-Packard
Robinson Sales Division
Shrewsbury
(201) 747-1060

Englewood, 07631

Hewlett-Packard
RMC Sales Division
391 Grand Avenue
(201) 567-3933

NEW MEXICO

Albuquerque, 87108
Hewlett-Packard
Neely Sales Division
6501 Lomas Blvd., N. E.
(505) 255-5586
TWX: 910-989-1665

Las Cruces, 88001
Hewlett-Packard
Neely Sales Division
114 S. Water Street
(505) 526-2486
TWX: 505-524-2671

NEW YORK

New York, 10021
Hewlett-Packard
RMC Sales Division
236 East 75th Street
(212) 879-2023
TWX: 710-581-4376

Rochester, 14625
Hewlett-Packard
Syracuse Sales Division
800 Linden Avenue
(716) 381-4120
TWX: 716-221-1514

Poughkeepsie, 12601
Hewlett-Packard
Syracuse Sales Division
82 Washington St.
(914) 454-7330
TWX: 914-452-7425

Syracuse, 13211
Hewlett-Packard
Syracuse Sales Division
5858 East Molloy Rd.
(315) 454-2486
TWX: 710-541-0482

NORTH CAROLINA

High Point, 27262
Hewlett-Packard
Southern Sales Division
1923 N. Main Street
(919) 882-6873
TWX: 510-926-1516

OHIO

Cleveland, 44129
Hewlett-Packard
Crossley Sales Division
5579 Pearl Road
(216) 884-9209
TWX: 216-888-0715

Dayton, 45409
Hewlett-Packard
Crossley Sales Division
1250 W. Dorothy Lane
(513) 299-3594
TWX: 513-944-0090

PENNSYLVANIA

Camp Hill
Hewlett-Packard
Robinson Sales Division
(717) 737-6791

Philadelphia Area
Hewlett-Packard
Robinson Sales Division
144 Elizabeth Street
West Conshohocken 19428
(215) 248-1600 and 828-6200
TWX: 215-828-3847

Pittsburgh Area

Hewlett-Packard
Crossley Sales Division
2545 Moss Side Blvd.
Monroeville 15146
(412) 271-5227
TWX: 710-797-3650

TEXAS

Dallas, 75209
Hewlett-Packard
Southwest Sales Division
P.O. Box 7166, 3605 Inwood Rd.
(214) 357-1881 and 332-6667
TWX: 910-861-4081

Houston, 77027
Hewlett-Packard
Southwest Sales Division
P.O. Box 22813, 4242 Richmond Ave.
(713) 667-2407
TWX: 713-571-1353

UTAH

Salt Lake City, 84115
Hewlett-Packard
Neely Sales Division
1482 Major St.
(801) 486-8166
TWX: 801-521-2604

VIRGINIA

Richmond, 23230
Hewlett-Packard
Southern Sales Division
2112 Spencer Road
(703) 282-5451
TWX: 710-956-0157

WASHINGTON

Seattle Area
Hewlett-Packard
Neely Sales Division
11656 N. E. 8th St.
Bellevue 98004
(206) 454-3971
TWX: 910-443-2303

CANADA

Montreal, Quebec
Hewlett-Packard (Canada) Ltd.
8270 Mayrand Street
(514) 735-2273
TWX: 610-421-3484

Ottawa, Ontario
Hewlett-Packard (Canada) Ltd.
1762 Carling Avenue
(613) 722-4223
TWX: 610-562-1952

Toronto, Ontario
Hewlett-Packard (Canada) Ltd.
1415 Lawrence Avenue West
(416) 249-9196
TWX: 610-492-2382

GOVERNMENT CONTRACTING OFFICES

Middletown, Pa. 17057
Hewlett-Packard
Contract Marketing Division
Olmsted Plaza
(717) 944-7401
TWX: 717-760-4816

West Conshohocken, Pa. 19428
Hewlett-Packard
Contract Marketing Division
144 Elizabeth St.
(215) 753-1811
TWX: 215-820-3847

HP INTERNATIONAL SALES AND SERVICE OFFICES

ARGENTINA

Mauricio A. Saurez
Telecomunicaciones
Carlos Calvo 224, Buenos Aires
Tel: 30-6312

AUSTRALIA

Sample Electronics (Vic.) Pty. Ltd.
9-11 Cremorne Street
Richmond E. 1, Victoria
Tel: 42-4757 (3 lines)

Sample Electronics (N.S.W.) Pty. Ltd.
4 Grose Street, Glebe, N.S.W.
Tel: 69-6338 (6 lines)

AUSTRIA

UNILABOR H.m.b.H.
Wissenschaftliche Instrumente
Rummelhardtgasse 6/3
P.O. Box 33, Vienna IX/71
Tel: 42 61 81

BELGIUM

Hewlett-Packard Benelux
20-24 Rue de l'Hopital, Brussels 1
Tel: 11.22.20

BRAZIL

CIENTAL IMPORTACAO E COMERCIO LTDA
R. Cons. Crispiano, 69, 8.ª Conj. 81
Sao Paulo, S.P.
Tel: 32-4332

CANADA

Hewlett-Packard (Canada) Ltd.
8270 Mayrand Street
Montreal, Quebec
(514) 735-2273

Hewlett-Packard (Canada) Ltd.
1762 Carling Avenue
Ottawa, Ontario
(613) 722-4223

Hewlett-Packard (Canada) Ltd.
1415 Lawrence Avenue W.
Toronto, Ontario
(416) 249-9196

CHILE

Hector Calcagni
Casilla 13942, Santiago
Tel: 6.42.26

DENMARK

Tage Olsen A/S
Rønnegade 1, Copenhagen Ø
Tel: 29.48.00

FINLAND

INTO O/Y
P. O. Box 153
11 Meritullinkatu, Helsinki
Tel: 6.11.33

FRANCE

Hewlett-Packard France
150 Blvd. Massena, Paris 13e
Tel: 707.97.19

GERMANY

Hewlett-Packard V.m.b.H.
Steindamm 35, Hamburg
Tel: 24.05.51

Hewlett-Packard V.m.b.H.
Kurfürststrasse 95
6 Frankfurt am Main
Tel: 52.00.36

Hewlett-Packard V.m.b.H.
Reginfriedstrasse 13
8 Munich 9
Tel: 49.51.21/22

Hewlett-Packard V.m.b.H.
Technisches Büro
Herrenbergerstrasse 110
703 Böblingen, Württemberg
Tel: 6971

GREECE

K. Karayannis
Klaffmonos Square, Athens 124
Tel: 230.301 (5 lines)

INDIA

The Scientific Instrument Company, Ld.
6, Tej Bahadur Sapru Road, Allahabad 1
Tel: 2451

The Scientific Instrument Company, Ld.
240, Dr. Dadabhai Naoroji Rd., Bombay 1
Tel: 26-2642

The Scientific Instrument Company, Ld.
11, Esplanade East, Calcutta 1
Tel: 23-4129

The Scientific Instrument Company, Ld.
30, Mount Road, Madras 2
Tel: 86339

The Scientific Instrument Company, Ld.
B-7, Ajmeri Gate Extn., New Delhi 1
Tel: 271053

IRAN

Telecom Ltd.
P. O. Box 1812, Tehran
Tel: 43850

ISRAEL

Electronics & Engineering Ltd.
16 Kremenetski St., Tel Aviv
Tel: 35021-2-3

ITALY

Hewlett-Packard Italiana S.p.A.
Viale Lunigiana 46, Milan
Tel: 69.15.84, 5 6

Hewlett-Packard Italiana S.p.A.
Palazzo Italia
Piazza Marconi, 25, Roma-Eur
Tel: 59.12.544/5

JAPAN

Yokogawa-Hewlett-Packard Ltd.
2270 Ishikawa-cho
Hachioji, Tokyo
Tel: Hachioji 0426-3-1231 (19 lines)

Yokogawa-Hewlett-Packard Ltd.
No. 3, 6-chome, Aoyama-Kitamachi
Akasaka, Minato-ku, Tokyo
Tel: 403-0073, 403-0074, 403-0075

Yokogawa-Hewlett-Packard Ltd.
No. 8, Umeda, Kita-ku, Osaka City
Tel: 361-3084, 341-2095

Yokogawa-Hewlett-Packard Ltd.
No. 4, 3-chome, Himeikedori,
Chigusa-ku, Nagoya City
Tel: 75-8545

KOREA

American Trading Company, Korea, Ltd.
112-35 Sokong-Dong, Jung-ku
Seoul P. O. Box 1103, Seoul
Tel: 3-7049, 3-7613

NETHERLANDS

Hewlett-Packard Benelux N.V.
23 Burg Roelstraat, Amsterdam W.
Tel: (020) 13.28.98 and 13.54.99

NEW ZEALAND

Sample Electronics (N. Z.) Ltd.
8 Matipo Street
Onehunga S. E. 5, Auckland
Tel: 565-361

NORWAY

Morgenstjerne & Co. A/S
Ingeniørfirma
6 Wessels Gate, Oslo
Tel: 20 16 35

PORTUGAL

TELECTRA
Rua Rodrigo da Fonseca 103
P. O. Box 2531, Lisbon 1
Tel: 68 60 72 and 68 60 73 and 68 60 74

PUERTO RICO & VIRGIN ISLANDS

San Juan Electronics, Inc.
150 Ponce de Leon, Stop 3
P. O. Box 5167
Pta. de Tierra Sta., San Juan 00906
Tel: 722-3342, 724-4406

SPAIN

ATAIO, Ingenieros
Enrique Larreta 12, Madrid 6
Tel: 235.43.44 and 235.43.45

SOUTH AFRICA

F. H. Flanter & Co. (Pty.), Ltd.
Rosella House
Buitenging Street, Cape Town
Tel: 3-3817

SWEDEN

H-P Instrument AB
Centralvägen 28, Solna, Centrum
Tel: 08-83.08.30 and 10-83.08.30

SWITZERLAND

Max Paul Frey
Wankdorffeldstrasse 66, Berne
Tel: (031) 42.00.78

TAIWAN (FORMOSA)

Hwa Sheng Electronic Co., Ltd.
21 Nanking West Road, Taipei
Tel: 4 6076, 4 5936

TURKEY

TELEKOM Engineering Bureau
P.O. Box 376—Galata, Istanbul
Tel: 49.40.40

UNITED KINGDOM

Hewlett-Packard Ltd.
Dallas Rd., Bedford, England
Tel: Bedford 68052

VENEZUELA

Citec, C. A.
Edif. Arisañ-Of #4
Avda. Francisco de Miranda-Chacaito
Apartado del Este 10.837, Caracas
Tel: 71.88.05

YUGOSLAVIA

Belram S.A.
83 Avenue des Mimosas
Brussels 15, Belgium
Tel: 35.29.58

For Sales and Service Assistance in Areas Not Listed Contact:

IN EUROPE

Hewlett-Packard, S. A.
54 Route des Acacias
Geneva, Switzerland
Telephone: (022) 42.81.50
Telex: 2.24.86
Cable: HEWPACKSA

IN LATIN AMERICA

Hewlett-Packard Inter-Americas
1501 Page Mill Road
Palo Alto, California 94304, U.S.A.
Telephone: (415) 326-7000
TWX: 910-373-1267
Telex: 033811 Cable: HEWPACK

ELSEWHERE

Hewlett-Packard
International Marketing Department
1501 Page Mill Road
Palo Alto, California 94304, U.S.A.
Telephone: (415) 326-7000
TWX: 910-373-1267
Telex: 033811 Cable: HEWPACK

