

JAN 68

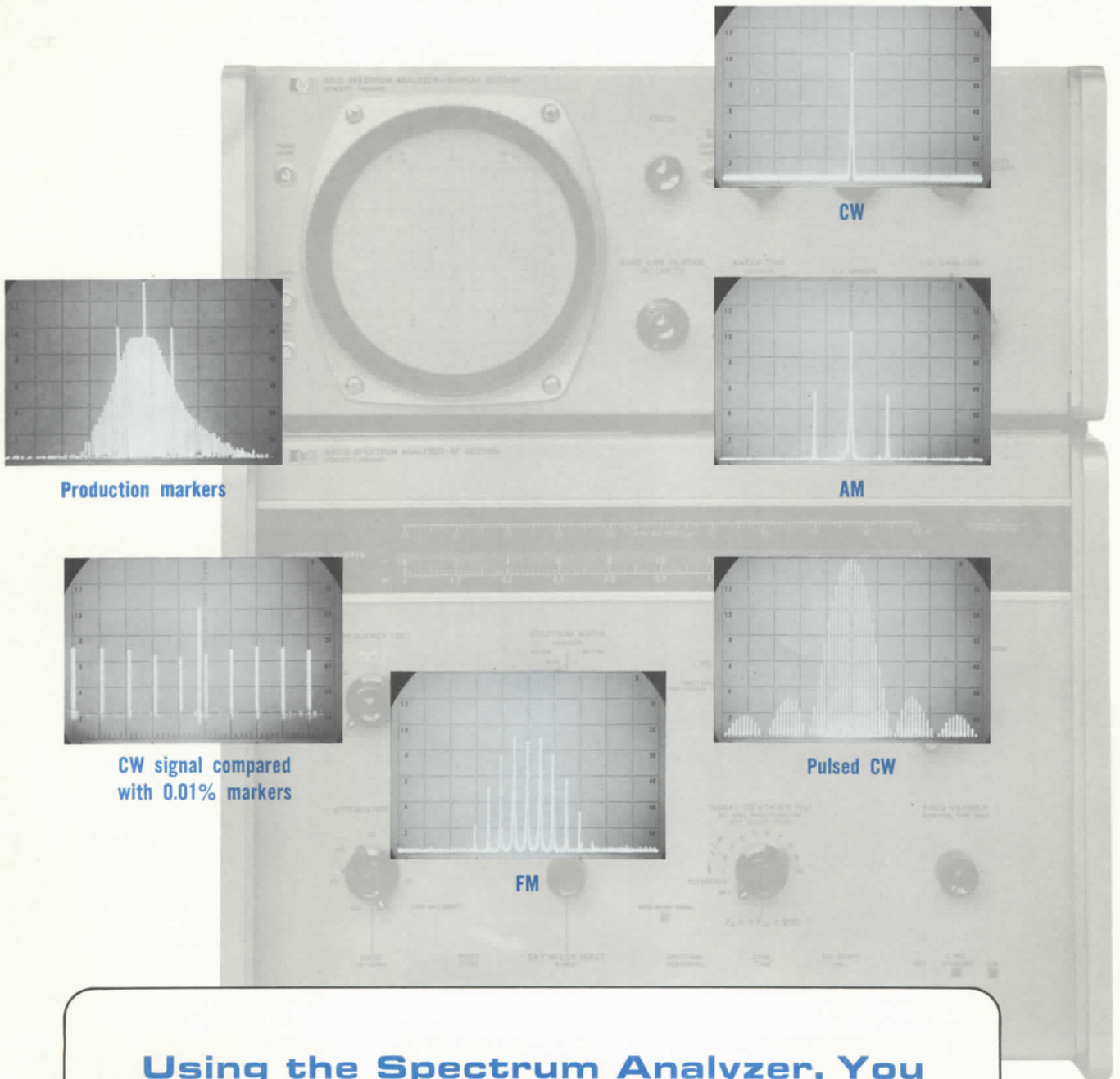

Production markers

CW

AM

CW signal compared  
with 0.01% markers

Pulsed CW

FM

### Using the Spectrum Analyzer, You Can Easily Measure Frequency:

- To 1% with the Analyzer Itself
- To 0.01% Using Broadband Markers

**CONTENTS**

	Page
INTRODUCTION . . . . .	3
FREQUENCY ACCURACY OF THE SPECTRUM ANALYZER . . . . .	3
USING MARKERS FOR FREQUENCY MEASUREMENT. . . . .	3
USING THE FREQUENCY COMB GENERATOR BELOW 5 GHz . . . . .	4
Accurate Determination of the Signal Frequency . . . . .	4
Accurately Setting Up a Reference Frequency . . . . .	5
USING THE FREQUENCY COMB GENERATOR ABOVE 5 GHz . . . . .	5
Establishing the Frequency of An Unknown Signal. . . . .	5
Setting Up a Reference Frequency . . . . .	5
CHECKING THE CALIBRATION OF THE SPECTRUM ANALYZER . . . . .	8
COUNTER READOUT . . . . .	8
FREQUENCY MARKERS FOR PRODUCTION TESTING . . . . .	8
APPENDIX . . . . .	10
DESCRIPTION OF THE HP 8406A FREQUENCY COMB GENERATOR. . . . .	10

## INTRODUCTION

Many techniques for making frequency measurements require converting information from the time domain to the frequency domain. However, the spectrum analyzer displays a signal directly in the frequency domain as a carrier with its sidebands, so that even a complex waveform can be easily measured. The cover photographs are examples of common frequency spectra. Notice how amplitude-modulated, frequency-modulated, and pulse-modulated signals are displayed with carrier and sidebands easily identified.

Using the techniques described in this note, you can make 0.01 percent accurate measurements in the frequency domain. Methods that result in readout convenient for specific applications are also described.

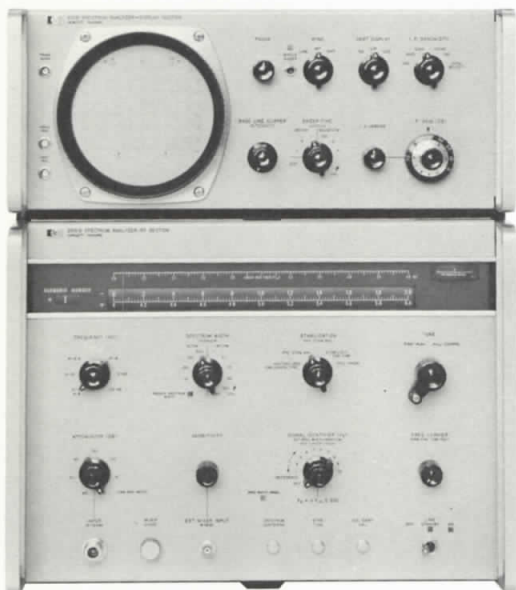

Figure 1. Hewlett-Packard Wideband Spectrum Analyzer

## FREQUENCY ACCURACY OF THE SPECTRUM ANALYZER

The spectrum analyzer is a swept, superhetrodyne receiver. A discussion of the theory and techniques of operation appear in AN63 and the 851/8551 Instruction Manuals. Here we will discuss those aspects of analyzer operation which effect frequency accuracy. A simplified block diagram appears in Figure 2.

The operating equation for the spectrum analyzer is

$$F_S = n F_{LO} \pm F_{IF} \quad (1)$$

Essentially, signal frequency,  $F_S$ , is compared with a harmonic of the first local oscillator frequency,  $F_{LO}$ . We see an indication on the CRT when the sum or difference between these frequencies equals the intermediate frequency,  $F_{IF}$ .  $F_S$  can be known only as accurately as  $F_{LO}$  and  $F_{IF}$  are known.

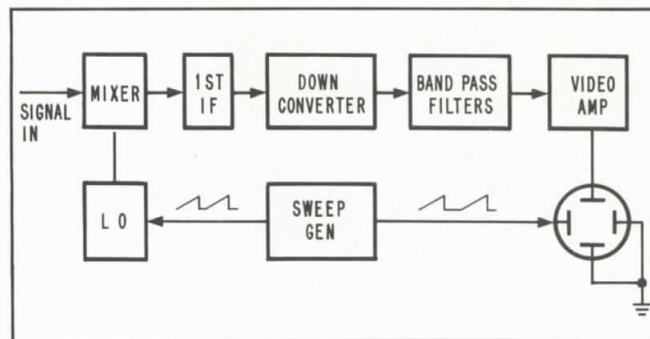

Figure 2. Spectrum Analyzer Block Diagram

In the HP 851B/8551B Spectrum Analyzer,  $F_{IF} = 2 \text{ GHz} \pm 220 \text{ kHz}$  and  $F_{LO}$  can be read from the frequency dial to 1%; thus, the fundamental dial accuracy of the unit is  $\pm 1\%$  of  $F_{LO} \pm 220 \text{ kHz}$ . Since  $2 \text{ GHz} < F_{LO} < 4 \text{ GHz}$ , the accuracy varies between 20 and 40 MHz. This could cause concern in low frequency measurements; however, accuracy is retained by reference to a zero frequency marker provided by LO feedthrough.\*

The frequency resolution of the spectrum analyzer is limited by the narrowest bandwidth in the signal path, the bandpass filters, (IF BANDWIDTH front panel switch). Resolution is defined as how close two signals can be and still be distinguished. This is the best accuracy to which two signals can be compared. The two signals should be of equal amplitude for optimum resolution.

## USING MARKERS FOR FREQUENCY MEASUREMENT

Although the internal frequency accuracy of the HP 851/8551 is adequate for most applications, it can be increased by using harmonics of a crystal marker oscillator such as the HP 8406A Frequency Comb Generator (Figure 3) as a reference. This frequency substitution method results in an accuracy of about  $\pm 0.01\%$  through 40 GHz.

Crystal calibrators have long been used to generate RF marker frequencies for calibrating receiver dials, frequency meters, wave meters, and other frequency-sensitive devices. However, by themselves, these calibrators are limited in frequency range because of the small amplitude of the higher harmonics. However, this range can be increased by taking advantage of the characteristics of step-recovery diodes. These diodes increase the harmonic content substantially by introducing sharp transients into the basic waveform.<sup>1</sup> As used in the 8406A Frequency Comb Generator, step-recovery diodes extend the frequency range of the crystal calibrator to well beyond 5 GHz.

\*LO feedthrough occurs since  $F_{LO}$  sweeps through  $F_{IF}$ , causing a signal indication. The solution of Equation 1 for this condition gives  $F_S = 0$  exactly.

(1) Robert D. Hall and Stewart M. Krakauer, "Microwave Harmonic Generation and Nanosecond Pulse Generation with the Step-Recovery Diode", *Hewlett-Packard Journal*, Vol. 16, No. 4, December 1964.

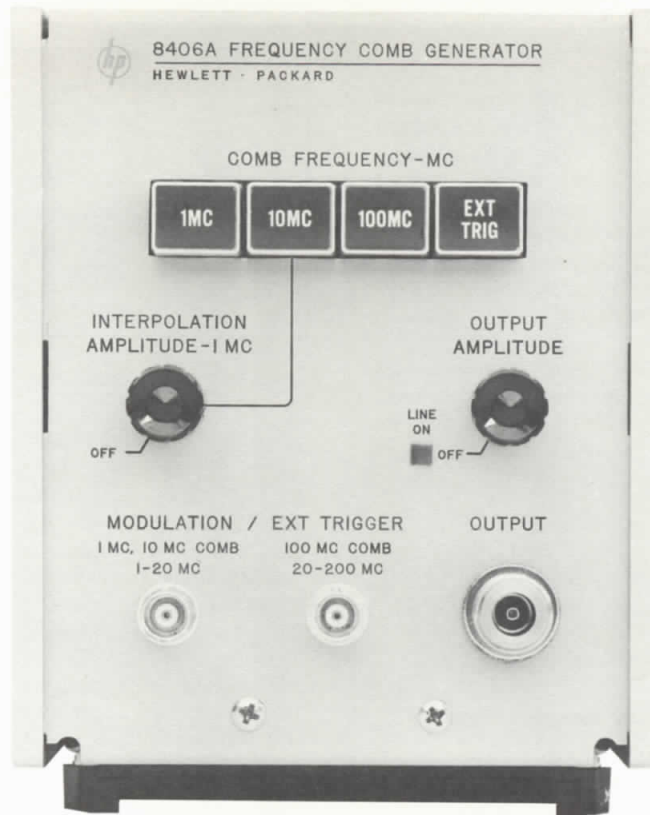

Figure 3. Model 8406A Frequency Comb Generator

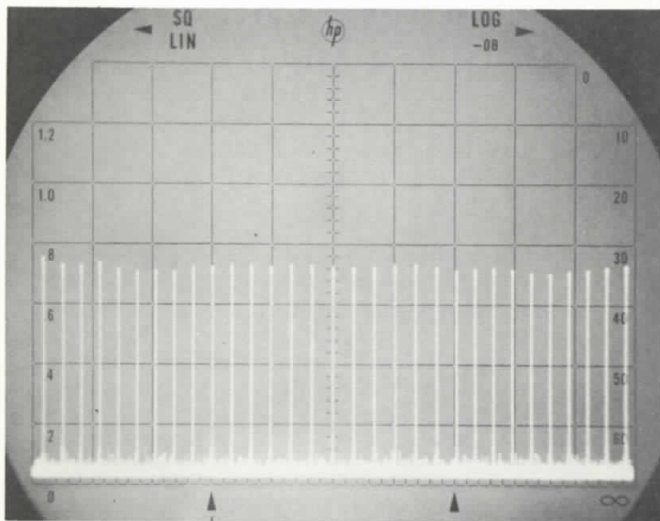

Figure 4. Portion of spectrum generated by Frequency Comb Generator as displayed on Spectrum Analyzer. Portion of comb shown here is 300 MHz band of 10-MHz components (display is set for 30 MHz/cm spectrum width). Frequency components shown here, with spectrum analyzer set for logarithmic response, have amplitudes that differ by less than 2 dB

The comb generator output is a series of regularly spaced frequencies markers harmonically related to the fundamental crystal frequency. On a plot of signal amplitude versus frequency displayed by a spectrum analyzer, the output resembles a comb; therefore, the instrument is called a frequency comb generator. The comb spacing is dependent on the frequency of the reference oscillator. (See Figure 4).

Each comb tooth has the frequency accuracy of the fundamental oscillator. By simultaneously viewing the frequency comb and an unknown signal, frequency comparisons may be made. Essentially, the accuracy of the reference oscillator has been transferred to the unknown frequency.

A further description of the operation and versatility of the 8406A Frequency Comb Generator appears in the Appendix.

### USING THE FREQUENCY COMB GENERATOR BELOW 5 GHz

#### Accurate Determination of the Signal Frequency

The frequency comb generator is used to accurately determine the frequency of an unknown signal. As described in Example 1, the signal is compared with the nearest 1-MHz comb tooth. The accuracy of such a measurement is the possible absolute frequency error of the comb ( $\pm 0.01\%$ ) plus or minus the possible error

in the analyzer frequency display calibration (sweep linearity) that was used in measuring the last increment (5% for the Model 851B/8551B Spectrum Analyzer). In the case described in Example 1, the maximum possible error is

$$(\pm .0001)(1850 \text{ MHz}) \pm (.05)(.35 \text{ MHz}) = 0.2025 \text{ MHz},$$

or 0.011%. The accuracy in this case is determined primarily by the 1-MHz crystal oscillator in the frequency comb generator; the linearity of the spectrum analyzer sweep is of secondary importance.

Accurately Setting Up a Reference Frequency

It is often desirable to set up a center frequency, band edge or test limit for many applications such as go/no-go tests. In this case, no signal is available and the nearest 1-MHz frequency comb is progressively then brought to the center of the screen then to a convenient reference. Example 2 in the next section explains the procedure.

**USING THE FREQUENCY COMB GENERATOR ABOVE 5 GHz**

Although the upper limit of the frequency comb generator is 5 GHz, it can be used to calibrate the spectrum analyzer up to the analyzer's maximum frequency. This is possible because the analyzer local oscillator sweeps from 2 to 4 GHz, which is within the range of the frequency comb generator. By viewing the frequency comb generator in a fundamental mixing mode ( $n = 1$ ), the local oscillator is calibrated to .01% according to the following equation:

$$F_c = F_{LO} - F_{IF}, \tag{2}$$

where

$F_c$  = comb frequency

$F_{LO}$  = local oscillator frequency

$F_{IF}$  = 2 GHz = first IF frequency.

Then, using the operating equation for the spectrum analyzer,

$$F_s = n F_{LO} \pm F_{IF}, \tag{3}$$

where

$F_s$  = signal frequency

$n$  = harmonic number.

$F_s$  is known to the same percent accuracy as  $F_{LO}$ , no matter what the value of  $n$ .\*

\*The  $\pm 220$  kHz tolerance on the spectrum analyzer 2-GHz first IF introduces an error of .004% at 5 GHz and of .001% at 20 GHz.

Establishing the Frequency of An Unknown Signal

Substituting the expression for  $F_{LO}$  from Equation (2) in Equation (3) and solving for  $F_s$ , we get

$$F_s = nF_c + 2 \text{ GHz } (n \pm 1). \tag{4}$$

This equation is in a convenient form to determine the frequency of an unknown signal,  $F_s$ .  $F_c$ , the comb generator frequency, is determined by counting down in the fundamental mixing mode; the procedure can be generalized from Example 1. The value for  $n$  and the appropriate  $\pm$  sign are found by using the 8551 signal identifier.

Setting Up a Reference Frequency

To set up a reference frequency accurately above 5 GHz, Equations (2) and (3) must be manipulated in a different manner to yield the frequency of the necessary comb tooth reference.

Solving Equation (3) for  $F_{LO}$  yields

$$F_{LO} = \frac{F_r - (\pm 2 \text{ GHz})}{n}$$

( $F_s$  has been replaced by  $F_r$ , the desired reference frequency).

Substituting this equation in equation (2)

$$F_c = \frac{F_r - (\pm 2 \text{ GHz})}{n} - 2 \text{ GHz}$$

$$F_c = \frac{F_r - 2 \text{ GHz } (n \pm 1)}{n} \tag{5}$$

Given a reference frequency,  $F_r$ , one can determine the proper local oscillator harmonic number and sign from Equation (3), or from the spectrum analyzer dial, or from Figure 5. These values, used in Equation (5) to solve for  $F_c$ , give the comb tooth frequency to use with fundamental mixing to set up the reference frequency. Example 2 illustrates the procedure. A pre-selector (HP 8441A) can be used to eliminate multiple responses after the center frequency has been set up.

### EXAMPLE 1

#### ACCURATE DETERMINATION OF A SIGNAL FREQUENCY ON A SPECTRUM ANALYZER

The series of photographs shown here illustrate how the frequency comb generator described in the accompanying article can be used to improve the accuracy of frequency determination with a broadband spectrum analyzer. Figure (a) shows the analyzer display of a signal combined with the 100-MHz comb. The large spike at the left is caused by local oscillator feedthrough in the spectrum analyzer and provides a convenient zero frequency reference. Counting the comb frequency components from the left shows that the signal lies between 1800 and 1900 MHz. Now the analyzer is tuned to place 1800-MHz marker at zero cm and the analyzer spectrum width is set to 10 MHz/cm (Figure b). Switching to the 10-MHz comb and again counting harmonics shows that the signal is between 1840 and 1850 MHz (Figure c). The spectrum width is next switched to 1 MHz/cm (d) and the 1-MHz components are added to the 10-MHz comb, as in Figure (e), which shows that the signal is between 1847 and 1848 MHz. With the horizontal scale expanded to 100 kHz/cm, the signal frequency is read as 1847.35 MHz (Figure f).

(a)  
100 MHz  
Comb

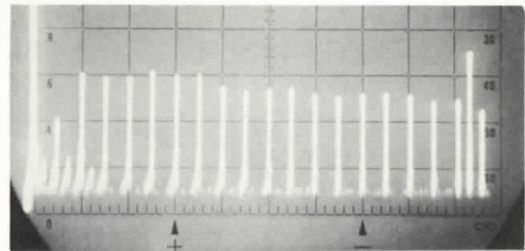

(b)  
10 MHz/cm

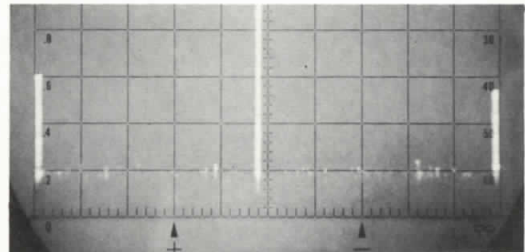

(c)  
10 MHz  
Comb

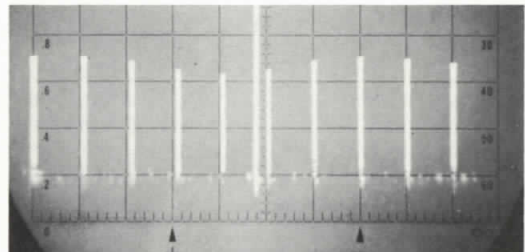

(d)  
1 MHz/cm

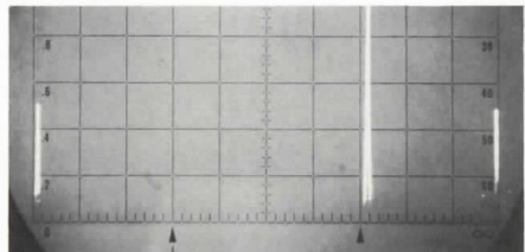

(e)  
1 MHz  
Comb

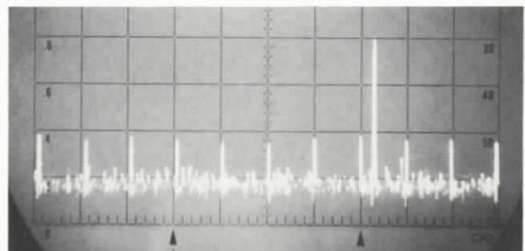

(f)  
1 MHz  
Comb  
100 kHz/cm

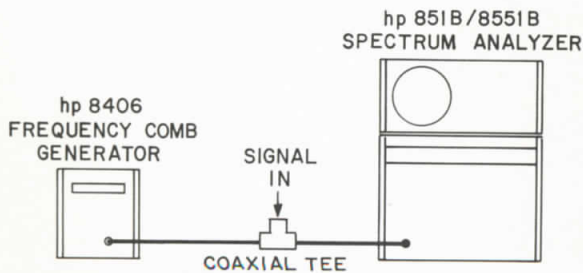
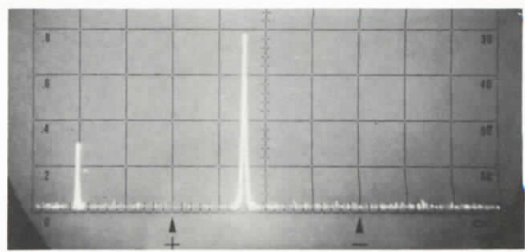

### EXAMPLE 2

For an example, we will set up a reference frequency at 7.5 GHz. From Figure 5 we see that the 2+ mixing mode is required. Substituting in Equation (5),

we get

$$F_c = \frac{7.5 - 2 \times (2 + 1)}{2} = \frac{1.5}{2} = 0.75 \text{ GHz} = 750 \text{ MHz.}$$

We will set the 750-MHz comb tooth at the 1-cm graticule line on the CRT face. The test setup of Figure d is used. The spectrum centering adjustment must be made on the 8551B Spectrum Analyzer RF Section as described in its instruction manual before proceeding. With the 100-MHz comb and the spectrum width at 100 MHz/cm, the 700-MHz comb tooth is first identified (Figure a) and moved to the center of the CRT. Spectrum width is reduced to 10 MHz/cm and the 700-MHz line is moved to the 1-cm CRT graticule line. The 750 MHz marker is identified (Figure b) from the 10-MHz comb and moved to the center of the screen. The spectrum width is reduced as desired. Narrower spectrum widths provide greater resolution, limited only by the bandwidth and LO stability. Phase-lock will be required as spectrum width is reduced below 1 MHz per cm. Set frequency switch for  $n = 2$ . The 750-MHz line is then moved to the left 1-cm line on the CRT (Figure c). The 7.5-GHz band-edge is now referenced to the 1-cm line on the CRT using the 2+ mixing mode, with an accuracy of  $\pm 0.01\%$ . The next graticule line over is 7.5001 GHz in the 100 kHz/cm position with an accuracy of  $\pm 0.01\%$  plus or minus the possible error in the frequency display calibration.

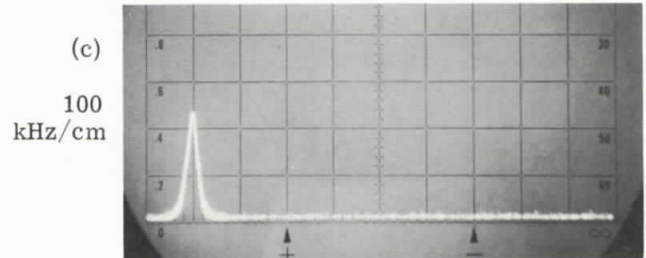
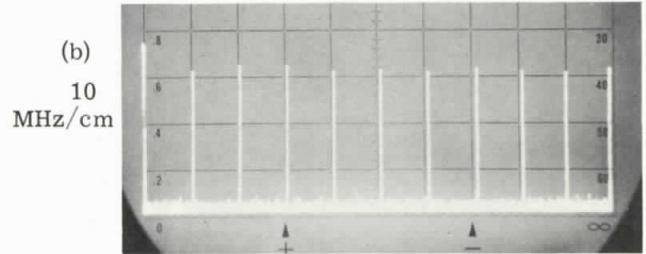
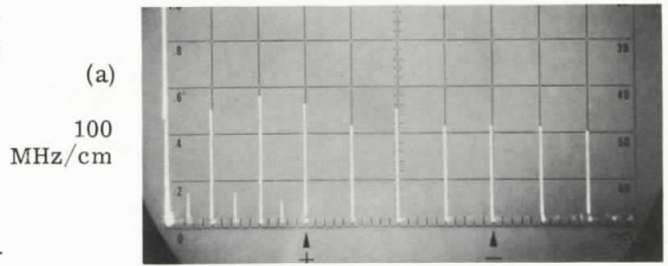

#### Test Set Up for Using the 8406 between 5 GHz and 12.4 GHz Coax Input

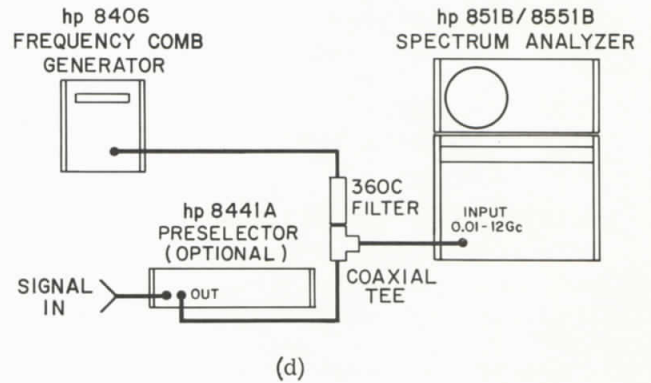

#### Test Set Up with External Mixers

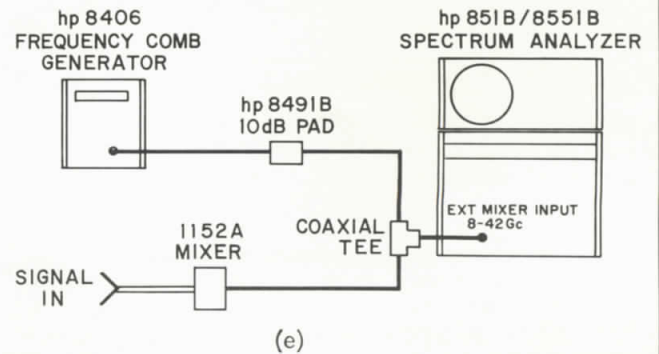

Note: The markers are generated by mixing the 2 GHz - 4 GHz with the comb in the input of the 8406.

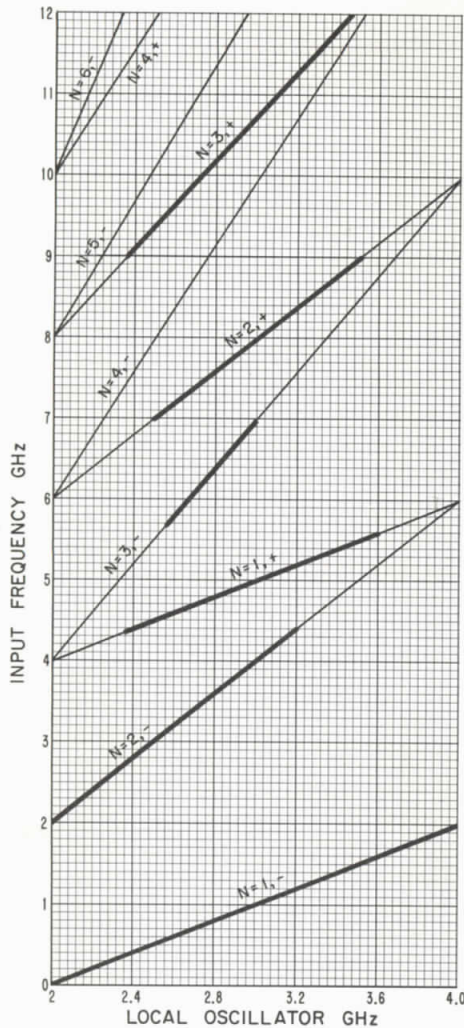

Figure 5. HP 851B/8551B Tuning Curves

### CHECKING THE CALIBRATION OF THE SPECTRUM ANALYZER

The comb generator can also be used as a source of input signals to check the accuracy of the spectrum analyzer tuning dial. The dial cursor is set to the frequency of a comb component and the displacement of that component with respect to the center of the CRT display is observed. Sweep calibration accuracy and linearity can also be checked by measuring the separation between the displayed comb components.

### COUNTER READOUT

A counter often cannot be used to measure signal frequency directly because of insensitivity. But counter readout can be obtained on the spectrum analyzer by using the transfer oscillator technique, at the expense of a swept display. The setup is shown in Figure 6. The signal of interest is brought to the center of the screen and the sweep width is reduced to zero using the vernier. Now the local oscillator is operating in the CW mode (the spectrum analyzer is operating as a fixed-tuned receiver). Since the LO output level is

about +13 dBm, its frequency can be counted with a high frequency counter (2 to 4 GHz). The counter is connected through a 10-dB pad to the local oscillator output port (remove the 50Ω load) on the back of the spectrum analyzer. Then using the spectrum analyzer operating equation

$$F_s = n F_{LO} \pm 2 \text{ GHz},$$

the value of  $F_s$  is found. The signal identifier is used to establish  $n$  and the  $\pm$  sign. Note that the  $\pm 220$  kHz tolerance on the 2-GHz IF must now be considered, for it limits the accuracy. When returning to swept analyzer operation, the counter should be turned off or disconnected because its internal oscillator may generate spurious responses on the spectrum analyzer. These spurious signals will appear to one side of the analyzer center frequency and are not a problem when making the measurement without sweeping the LO.

### FREQUENCY MARKERS FOR PRODUCTION TESTING

You may wish to set up markers around a specific center frequency for production testing; for instance, checking a filter in its stop and pass bands. This may be done easily by amplitude-modulating a signal set at the desired center frequency. This signal, with its sidebands, is fed into the input of the spectrum analyzer through one part of a directional coupler, a power divider, or coaxial tee. The signal under test is fed in through the other port.

For markers close to the center frequency, the signal generator itself may be modulated. (The maximum modulation frequency is dependent on the signal generator used to generate the center frequency.) Markers further away must be generated externally by overdriving a broadband mixer. The HP Model 10514A is a suitable broadband mixer (200 kHz to 500 MHz); for frequencies to 15 GHz, the Sage Model 242 is useful. The marker generators should have an output greater than -10 dBm. Marker amplitude is dependent on the power incident on the mixer.

The test setup is shown in Example 3. In a, 10-MHz markers are being generated around 500 MHz to check the stop band specification of a bandpass filter. Figure b shows 3-MHz markers being generated to check the pass band of the filter. Using this technique, accuracy is limited only by the frequency accuracy of the signal generators used.

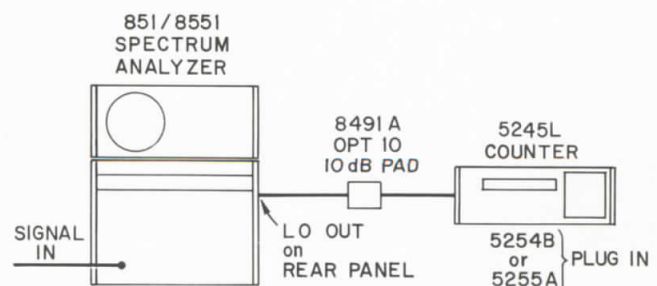
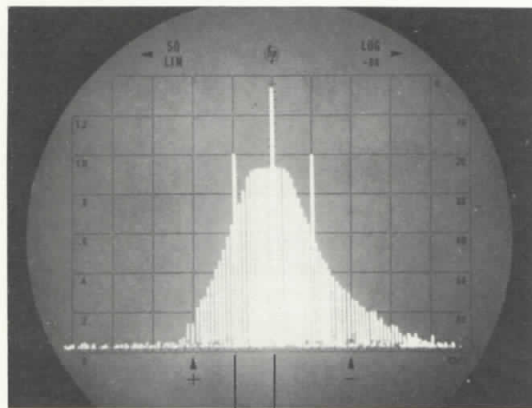
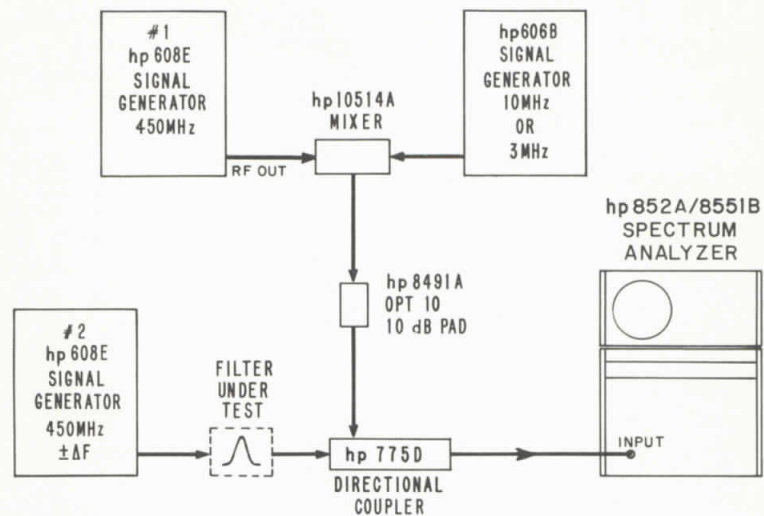
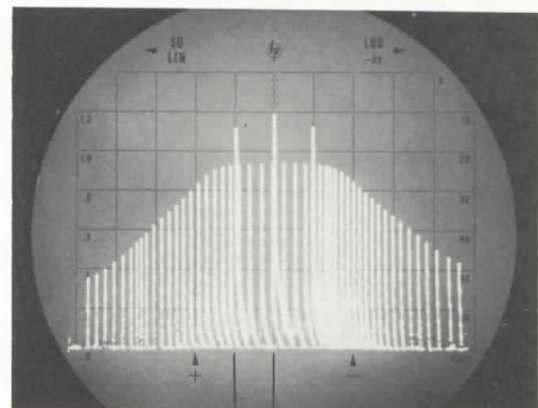

Figure 6. Obtaining Counter Readout with the Spectrum Analyzer. Here, the local oscillator frequency is measured. The signal frequency is found through the spectrum analyzer operating equation,  $F_s = nF_{LO} \pm 2\text{GHz}$ .

EXAMPLE 3



(a) ← 10MHz



(b) ← 3MHz

Example 3. Markers used to check a filter characteristic. The second 608E frequency is varied, tracing out the filter passband. (a) 10-MHz markers check the stop band. It is easily seen that the stop band is at least 10 dB down at 10 MHz. (b) 3-MHz markers are used to check the passband. Flatness, 3 dB points, etc., are easily checked. (Note that the 852 variable persistence display is used here for convenience.)

## APPENDIX

### DESCRIPTION OF THE HP 8406A FREQUENCY COMB GENERATOR

The comb generator has three internal crystal-controlled oscillators at frequencies of 1, 10, and 100 MHz. A step-recovery diode shapes the oscillator outputs into extremely narrow pulses. The narrow pulse width (less than 100 picoseconds) provides marker frequencies of useful amplitude from 1 MHz to beyond 5 GHz. Frequency accuracy of each oscillator and, thus, each harmonic component is  $\pm 0.01\%$ .

In the time domain, the output of the frequency comb generator is a train of narrow, positive pulses at a repetition rate that is the frequency of the selected internal crystal-controlled oscillator or of an external source. (Figure A-1) Calculations based on the amplitude and number of frequency components as displayed on a spectrum analyzer indicate that the pulses actually are less than 70 ps wide and have an amplitude of about 3/4 volt.

The spectrum, or frequency domain representation, of a pulse train consists of a dc component, a fundamental frequency component (the repetition rate), and higher frequency components occurring at harmonics of the fundamental, as shown in Figure A-2. \* Since the output waveform approximates an impulse, each harmonic component, including the fundamental, has approximately the same amplitude. However, the pulses do have a finite width,  $T_w$ , so that the envelope of the spectrum falls off as the frequency of the harmonic components approaches  $1/T_w$  and may actually go through a null at frequency  $1/T_w$ . Because the pulse

\* Actually, no dc appears in the output of the frequency comb generator because of a shorted-stub differentiator in the output circuit.

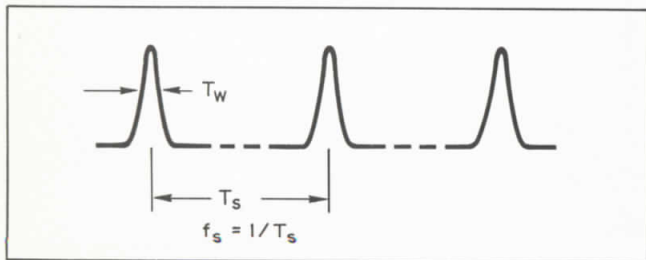

Figure A-1. Time domain representation of output pulse train of frequency comb generator. Pulse width is designated  $T_w$  and pulse rate period is  $T_s$ . Actual pulses have ratio of  $T_w/T_s$  that ranges from less than 0.0001 to 0.01.

width of the frequency comb generator has been made less than 100 picoseconds, the null occurs beyond 10 GHz and useful spectrum content thus extends well beyond 5 GHz.

The frequency comb generator can also be driven by an external sine wave in the 1- to 200-MHz range (the sine wave should have an amplitude of 1 to 3 volts rms). The resultant comb then has the frequency spacing, accuracy, and long term stability of the external signal. This function enables a 1- or 5-MHz frequency standard to be extended up to hundreds or thousands of MHz by harmonic multiplication.

Each of the internal combs can be phase-modulated over a wide modulation frequency range by applying a low level signal (1 to 100 mV) to the appropriate external trigger input while the desired "comb frequency" button is depressed. Low-index phase modulation produces sidebands astride each tooth of the comb, spaced from the main comb by the modulation frequency. As an example, Figure A-4 shows the 1000-MHz and 1100-MHz components with 20-MHz sidebands resulting from modulation of the 100-MHz comb with a 20-MHz signal. The instrument is designed to enable the 1-MHz oscillator to phase-modulate the 10-MHz comb, generating lower level 1-MHz components in the 10-MHz spectrum (Figure A-5).

These techniques can be used for interpolation purposes when determining the frequency of a signal appearing on the spectrum analyzer. The modulation frequency provided by an external source is varied until the sideband coincides with the unknown signal. Then the unknown frequency is the frequency of the main comb harmonic component  $\pm$  the modulation frequency, depending on whether an upper or lower sideband is made to coincide.

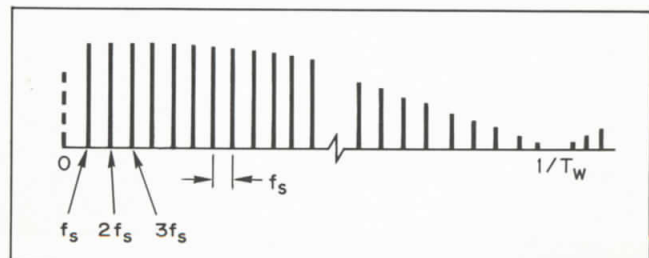

Figure A-2. Frequency domain representation of pulse train shown in Figure A-1. With ideal pulses, frequency components would be of near identical amplitude out to  $1/T_w$  and may go through a null at a frequency of  $1/T_w$ .

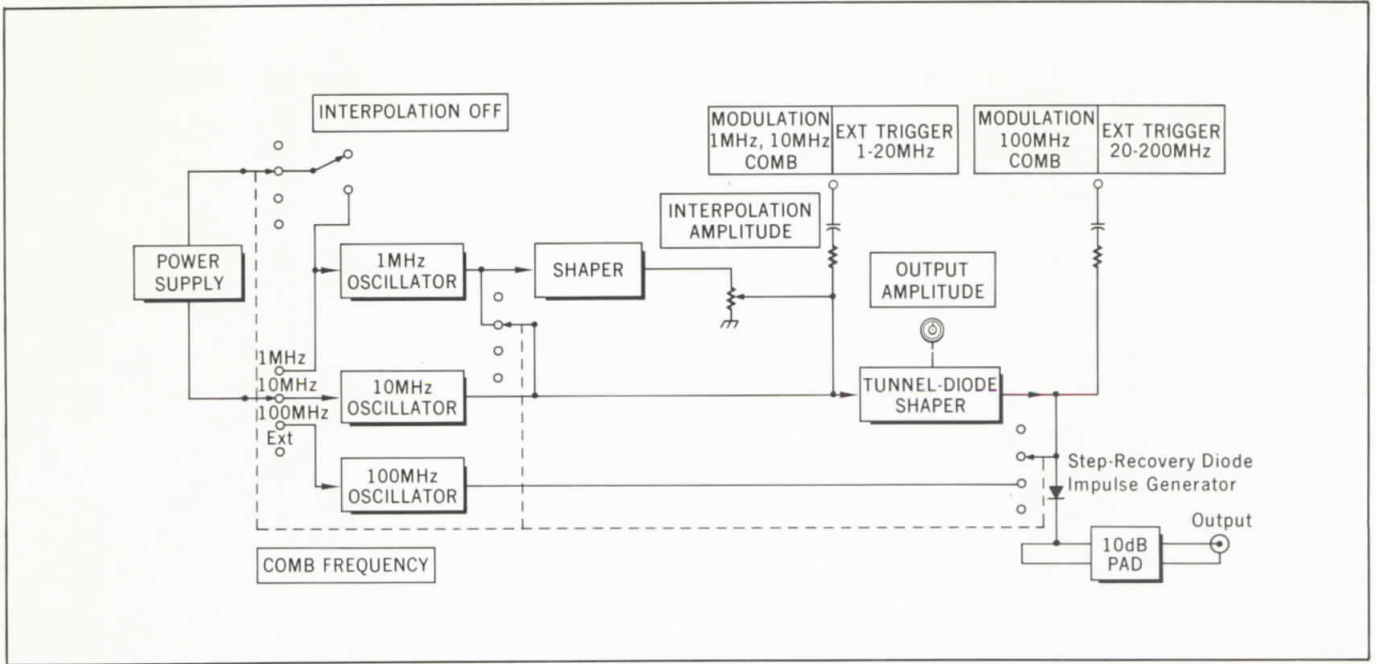

Figure A-3. Block diagram of frequency comb generator. Step-recovery diode working into shorted-stub line differentiator generates output impulse. One of three crystal oscillators energized by front panel push buttons drives step recovery diode. Tunnel-diode shaper speeds up rise times of lower frequency drive signals sufficiently to drive step recovery diode. 10-dB pad makes output impedance a nominal 50 ohms because of low impedance of shorted stub.

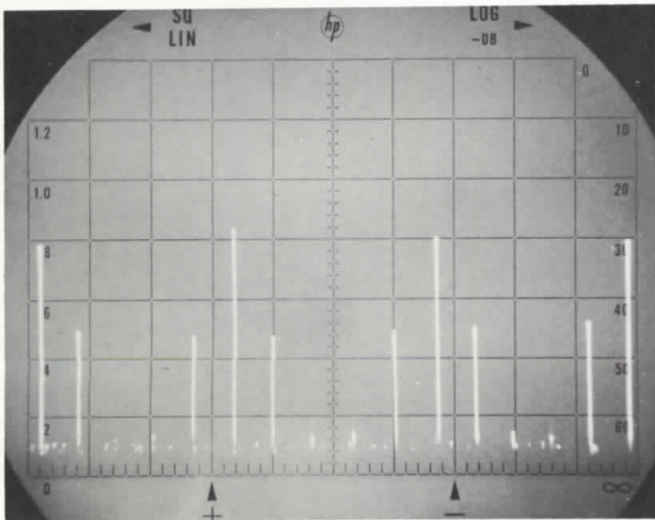

Figure A-4. Phase modulation of the 100-MHz comb by 20-MHz sine wave results in sidebands astride each "tooth" of the frequency comb. The sidebands are useful for interpolation purposes. Shown here are 1000 MHz and 1100 MHz comb components (large amplitude responses) with 980, 1020, 1080, and 1120 MHz sidebands.

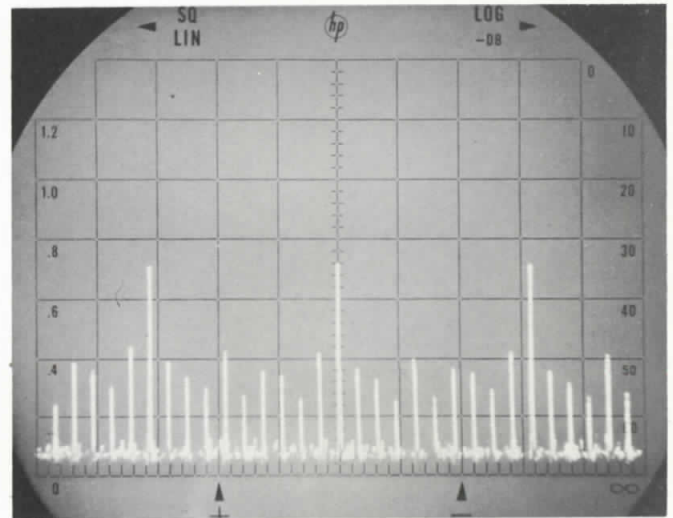

Figure A-5. 10-MHz frequency comb with added 1-MHz components. Higher amplitude of 10-MHz components provides decade scale marks for easier identification of 1-MHz increments.

