

TECHNICAL DATA 1 MAY 68

Broadband Analyzer Display

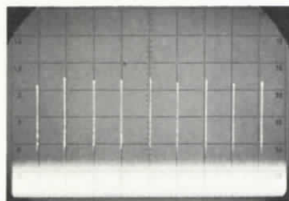

Display Preselected

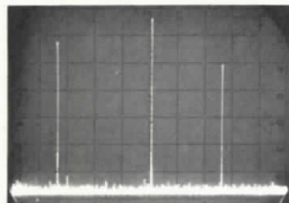
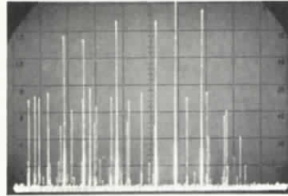
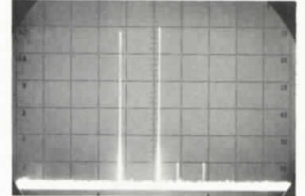

Eliminate spurious signals  
caused by strong signal  
intermodulation

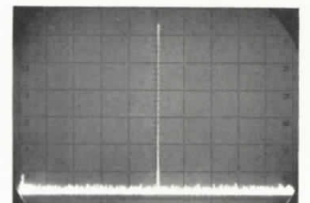

Select the desired mixing  
mode of the 851B/852A/  
8551B and automatically  
identify the input signal  
frequency

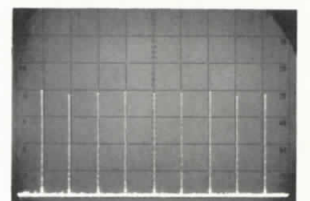

Improve your effective signal-  
to-noise ratio on broadband  
signals (frequency combs and  
very narrow pulses)

**Extend Your Effective Distortion  
Measurement Capability with  
the 851B/852A/8551B  
at Least 30 dB**

**Using the 8441A Preselector as a Programmable, Continuously  
Tunable, Bandpass Filter from 1.8 to 12.4 GHz, You Can:**

- **Select the Desired Harmonic in Frequency Multiplier Chains**
- **Ensure Low Harmonic Content from Your Sweep Oscillator, for Better Broadband Testing Accuracy**

### INTRODUCTION

The 851/8551 Spectrum Analyzer marked the breakthrough into broadband fully calibrated signal analysis. The spectrum from 10 MHz to 12.4 GHz could be displayed with a single sweep of the analyzer's local oscillator. The 851/8551 acts like a wide open super-heterodyne receiver. It accepts (in coax) any input signals between 10 MHz and 10 GHz, mixes them with the fundamental or harmonics of a sweeping 2 to 4 GHz local oscillator to produce a 2-GHz IF signal. This signal is heterodyned down to 20 MHz, amplified, and displayed on the CRT. Since all signals in the frequency range can produce a 2 GHz mixing product on at least one harmonic (some can mix with more than one), the display can become fairly cluttered. This is especially true when you're interested in a definite range of frequencies.

The problem of blocking the responses to signals that fall outside a desired frequency range was foreseen, and a series of interdigital filters was introduced as a partial solution. These help the analyzer user confine his investigation to a definite frequency range. The filters do not allow enough flexibility, however, as they have definite fixed passbands, restricting the choice of frequency ranges.

The 8441A Preselector offers a radical new solution to the problems of broadband analysis and fixed interdigital filters. It acts as a voltage-tuneable bandpass filter, automatically tracking the desired harmonic of the analyzer's local oscillator. This defines the frequency range displayed on the CRT, simplifying the presentation and making it easier to interpret.

In addition, the 8441A can be used as a manually tuned or voltage-tuned, narrow band filter with a center frequency anywhere from 1.8 to 12.4 GHz.

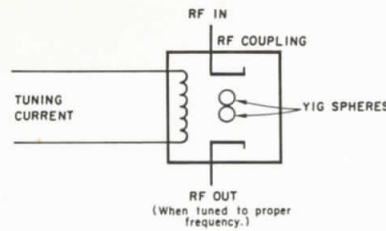

Figure 1. YIG Tuning Circuit

### HOW DOES THE PRESELECTOR OPERATE? THEORY OF OPERATION

The heart of the YIG preselector is an electronically tuneable YIG filter. Two spheres of YIG (Yttrium-Iron-Garnet) crystal material in a magnetic field are placed in the path of the RF signal. RF can only pass through the YIG filter when the spheres are at resonance. The frequency of resonance is a linear function of the magnetic field strength produced by the YIG tuning coil (see Figure 1). The coil's field is proportional to the tuning current, thus the resonant frequency of the YIG is directly proportional to the tuning current supplied to the YIG. Insertion loss of the YIG at resonance is less than 5 dB.

Off resonance, the YIG acts like a short circuit reflecting most of the RF energy back to the source. Both the input and the output of the 8441 should be operated into good matches (better than 1.5 VSWR) to realize optimum performance. The selectivity characteristic of the YIG filter is at least 6 dB/octave 200 MHz off resonance (see Figure 2).

### MODES OF OPERATION

The 8441A can be operated in the following three ways:

1. Swept internally.
2. Swept externally.
3. As a preselector for the 851B/852A/8551B Spectrum Analyzer.

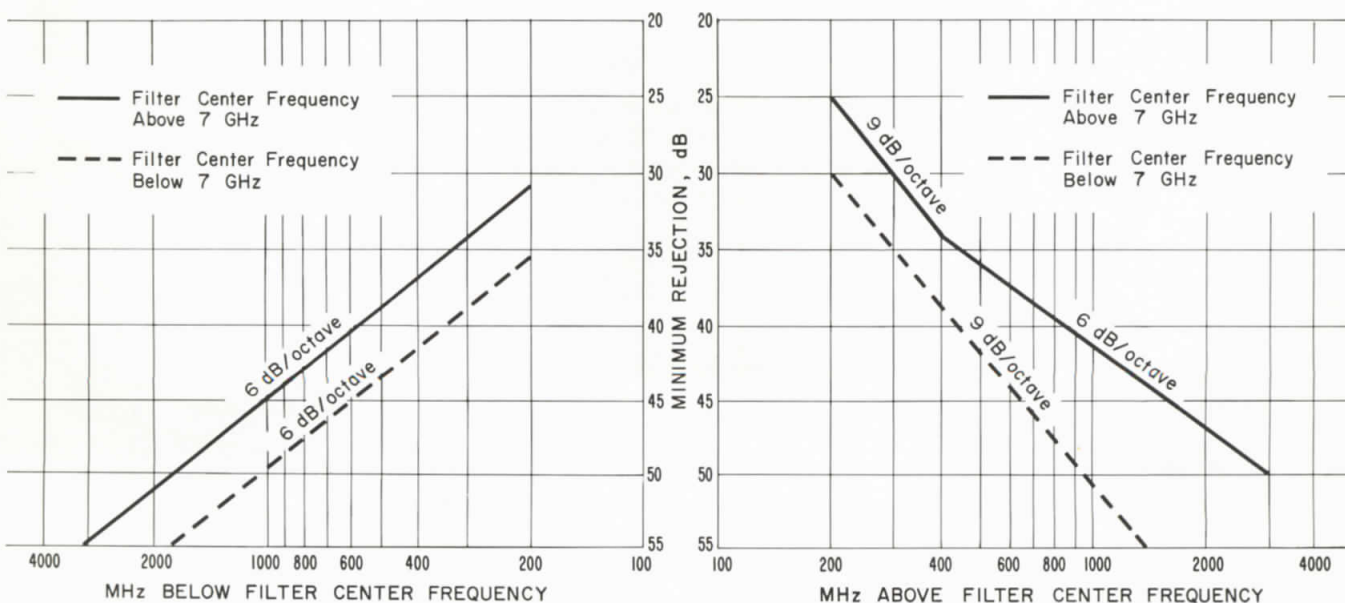

Figure 2. YIG Filter Selectivity

When the internal mode is selected on the 8441A's function control, a voltage ramp is generated internally to drive the YIG tuning coil at a constant 60-Hz rate. This ramp will sweep the passband of the 8441A across a frequency range selected by the "Center Frequency - GHz" and the "Sweep Width - GHz" controls. The former control defines the center frequency of the range to be swept (the midpoint of the ramp) while the latter sets the sweep limits of that center frequency (the end points of the ramp). The center frequency is continuously variable from 1.8 to 12.4 GHz, while the sweep width can be varied from 0 to 10 GHz. The 1.8 to 12.4 GHz frequency limits of the 8441 are set by the physical characteristics of the YIG spheres and therefore cannot be exceeded. Also, in the internal mode, the sweep width can be set to zero and the 8441A operated as a fixed-tuned bandpass filter. The "Center Frequency GHz" control will then tune the YIG's passband to any frequency between 1.8 and 12.4 GHz. The nominal filter bandwidth (-3 dB points) is 35 MHz; the exact bandwidth may vary from 20 to 70 MHz over the 1.8- to 12.4-GHz range.

In the external mode, either fixed voltages or ramps can tune the YIG. The maximum tuning rate is determined by the inductance of the YIG tuning coil. When switching between two fixed tuning voltages, as obtained from a programmable power supply, the YIG will tune to the new frequency in less than 10 ms. Excellent flexibility of the 8441A's input circuitry lets almost any external voltage be adapted to the requirements of the YIG. For instance, the 8441A can easily be set to track the HP 8690A Sweep Oscillator.

Primarily, however, the 8441A was intended to be a preselector for the 851B/852A/8551B Spectrum Analyzer. The electronic circuits (see Figure 3) of the 8441A match the tuning characteristics of the YIG filter and the spectrum analyzer. The preselector output jack on the 8551 provides the tuning voltage to the preselector input jack on the 8441A. This voltage is converted to the tuning current needed to drive the YIG electromagnet. In this way, the preselector will track a selected mixing mode, rejecting all undesired signals.

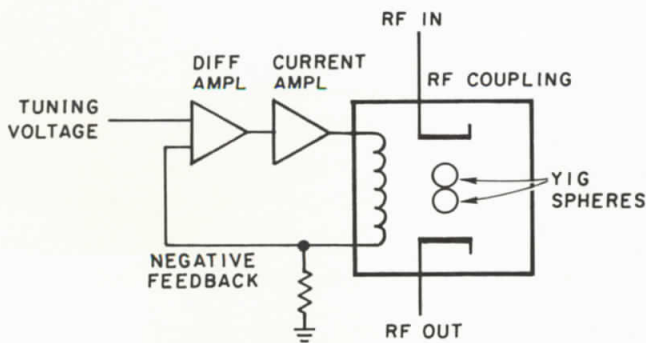

Figure 3. 8441 Simplified Block Diagram

## HOW DOES THE PRESELECTOR ACCOMPLISH ALL THIS?

1. How can you see only the desired signals on the HP 851B/852A/8551B Spectrum Analyzer?

Harmonic multiple, and spurious responses such as intermodulation (IM) distortion can be eliminated by using the 8441A Preselector. Before discussing how this is accomplished, it is necessary to review the basic operation of the 851B/852A/8551B Spectrum Analyzer.

The analyzer responds to input signals according to the following equation:

$$f_{RF} = nf_{LO} \pm 2 \text{ GHz}$$

As the fundamental of the analyzer's local oscillator (LO) tunes from 2 to 4 GHz, the analyzer responds to signal frequencies 2 GHz above and 2 GHz below the local oscillator frequency. These are shown on Figure 4 by the 1<sup>+</sup> and 1<sup>-</sup> tuning curves and are called image responses. Similarly, the second harmonic of the local oscillator tunes 4 to 8 GHz and the third harmonic tunes 6 to 12 GHz. The analyzer response to signals is shown by the 2<sup>+</sup>, 2<sup>-</sup>, 3<sup>+</sup>, and 3<sup>-</sup> tuning curves for these mixing modes. This means that when the

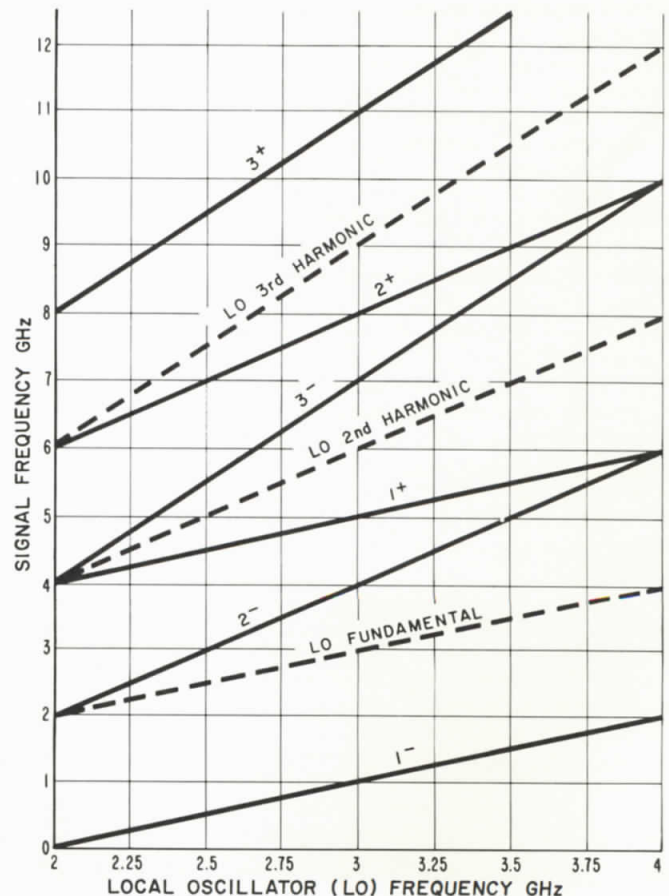

Figure 4. Tuning Curve of 851B/852A/8551B Spectrum Analyzer

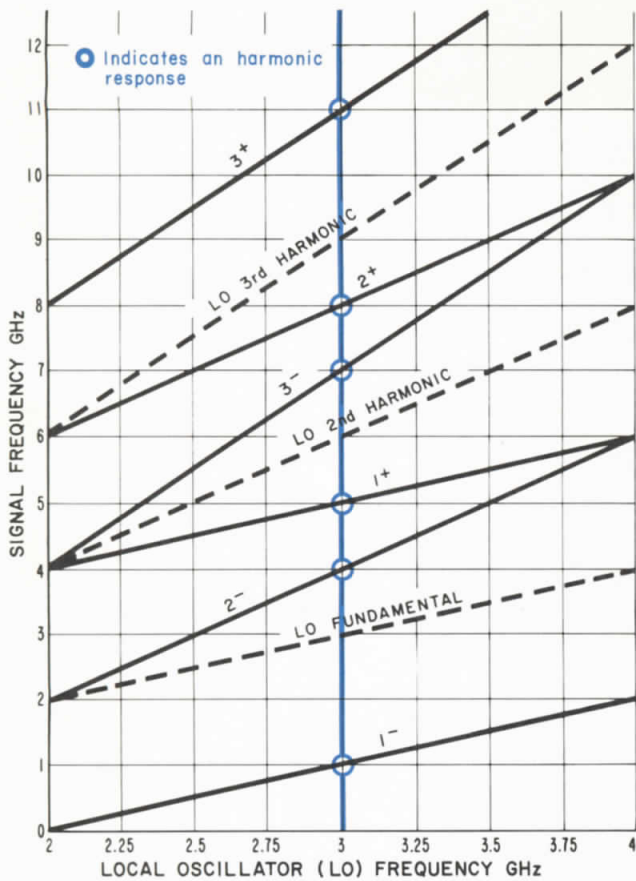

Figure 5. Analyzer Responses When LO is Tuned to 3 GHz

local oscillator is tuned to 3 GHz, for example, the analyzer can respond to six different signal frequencies (see Figure 5). These responses, called harmonic responses, are a very useful way of extending the frequency range of the analyzer display. They can all be readily identified, but they overlap on the display and can cause confusion in picking out any one special frequency. These responses are a result of the 851B/852A/8551B analyzer's ability to display the entire spectrum from 10 MHz to 12.4 GHz simultaneously. This may not be the most desirable mode of operation, however, if you are interested only in the responses in one specific frequency range. The 8441A Preselector allows you to observe just the one response you are looking for.

The analyzer can also mix with more than one local oscillator harmonic at a single input frequency. These display responses are called multiple responses and appear at different positions on the screen. For example, Figure 6 shows the analyzer responding at LO frequencies of 2.33, 3.00 and 3.50 GHz to a 5-GHz input signal. Substitution into  $f_{RF} = n f_{LO} \pm 2$  GHz produces:

$$\begin{aligned}
 5 &= 3 (2.33) - 2, \\
 5 &= 1 (3.00) + 2, \text{ and} \\
 5 &= 3 (3.50) - 2.
 \end{aligned}$$

Spurious responses are distortion products generated by the nonlinear behavior of the analyzer's input mixer when driven by signals greater than -30 dBm. In the

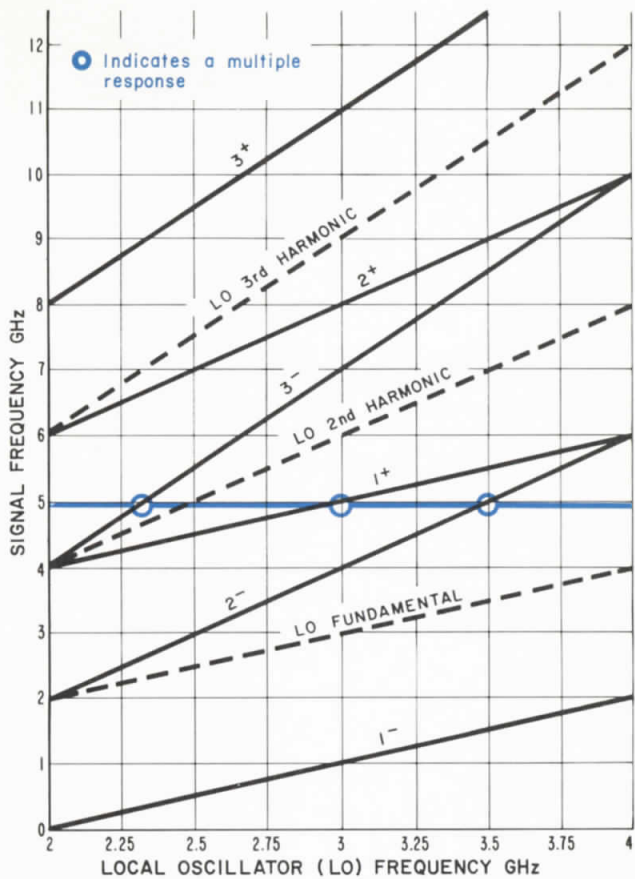

Figure 6. Analyzer Responses to a 5-GHz Input Signal

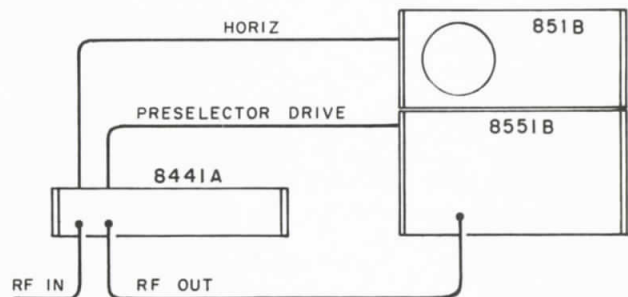

Figure 7. 8441A/851B/852A/8551B Setup Diagram

case of intermodulation distortion (IM), these distortion products are due to the interaction of two or more strong input signals in the mixer.

These three types of responses can have a complicating effect on the spectrum analyzer display. If, however, the 8441A is connected to the 851B/852A/8551B Spectrum Analyzer as illustrated in Figure 7, the effects of the undesired responses can be virtually eliminated.

The preselector's set frequency ranges have been carefully designed to keep the analyzer display always in the optimum portion of any harmonic response band. This assures optimum sensitivity and maximum rejection of undesired responses. For example, where two harmonic responses intersect at their upper or

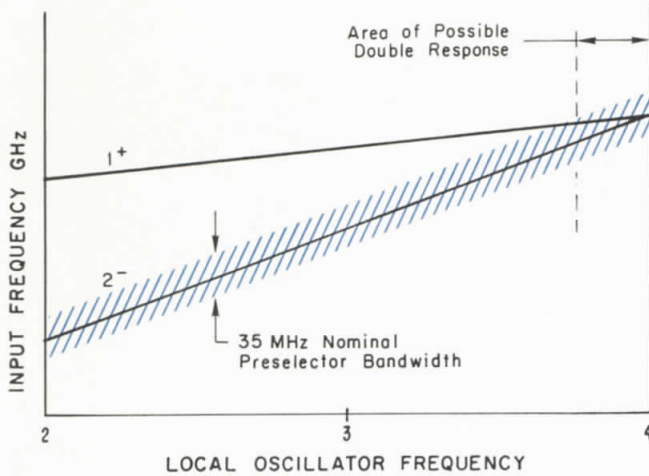

Figure 8. Local Oscillator Tracking

lower ends (see Figure 8) there are two possible responses within the passband of the 8441A. This is a normal occurrence and is avoided by switching to another mixing mode where your display will be more symmetrical. If the mixing modes suggested on the preselector are employed for the frequency ranges involved, all the benefits of preselection will be retained, i.e., a clear and easy to interpret CRT display.

How Does the Spectrum Analyzer React to the Harmonic Responses? Consider that 5-GHz and 8-GHz signals are simultaneously passed through an 8441A and into an 851B/852A/8551B. If the preselector is set to track the  $1^+$  mixing mode, it will pass only the 5-GHz signal when the LO is tuned to 3 GHz. The harmonic response to the 8-GHz signal that would occur at the same LO frequency (Figure 5) has been blocked by the preselector.

The multiple responses of the analyzer to the 5-GHz signal would also be eliminated. Figure 6 indicates multiples would occur at LO frequencies of 2.33, 3.00 and 3.50 GHz. Figure 9a is an oscillogram of these responses. Figure 9b shows the reduction of the  $2^-$  and  $3^-$  mixing responses when using the 8441A Preselector. When the LO frequency is 2.33 GHz, the preselector is tuned to 4.33 GHz (tracking the  $1^+$  response) and so rejects the 5-GHz signal. Similarly, the 5-GHz signal is rejected at the  $2^-$  mixing mode, since the preselector is then tuned to 5.5 GHz. The  $2^-$  and  $3^-$  mixing responses were selected in the same way, with the results shown in Figure 9c. The reduction of other than the desired mixing mode is typically greater than 35 dB.

A high power signal (above -30 dBm) will generate spurious responses in the 8551B mixer, but the preselector will eliminate their effects from the display. With the  $1^+$  mixing mode selected, the response to a 0-dBm, 5-GHz signal will be displayed when the LO is tuned to 3 GHz. When the LO is tuned so that the second harmonic (10 GHz) can produce a response, the 8441A is tuned off of the fundamental (5 GHz) and, therefore, attenuates the fundamental by more than 50 dB. No harmonics are produced in the mixer, and therefore no spurious responses appear on the display.

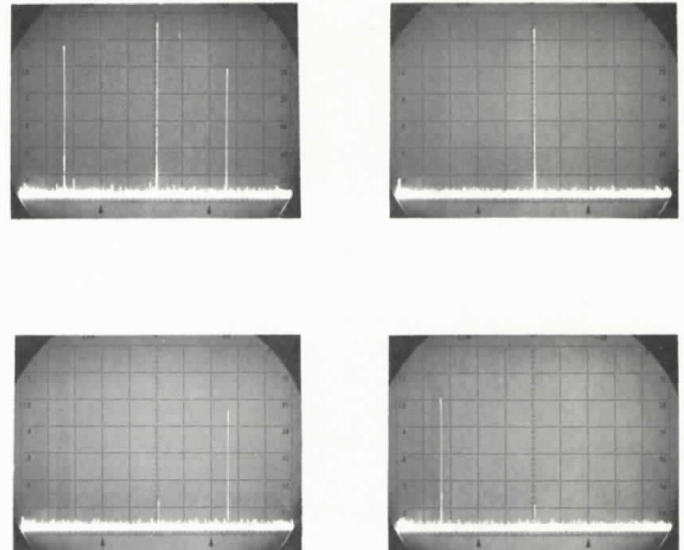

Figure 9. (a) Multiple Responses to 5 GHz Signal (b) Selection of  $1^+$  Response (c) Selection of  $2^-$  and  $3^-$  Responses

Preselection can also aid in the reduction of intermodulation between several strong signals applied to the analyzer's mixer. Figure 10a shows signals at 4.9 and 5.1 GHz. Due to the high input level to the mixer (about 0 dBm), the display is complicated by strong intermodulation products as well as the multiple responses from the  $3^-$  and  $2^-$  mixing modes. Figure 10b shows the substantial reduction of these responses when using the 8441A. Since the two input frequencies are far enough apart, the preselector passes only one signal to the mixer at any time. Since both signals are never present in the mixer simultaneously, intermodulation products cannot be produced. Use of the 8441A Preselector produces noticeable improvement in IM distortion between signals as closely spaced as 35 MHz. For example, consider two signals separated by 50 MHz (A and B). These produce second order distortion products at frequencies of  $2A-B$  and  $2B-A$ , both 50 MHz from the nearest fundamental (see Figure 11). When the spectrum analyzer and the preselector are tuned to receive the  $2B-A$  distortion signal, the passband of the 8441A reduces the level of signal B by 10 dB and signal A by 25 dB. The distortion products are thus at least 25 dB below what they were without the preselector.

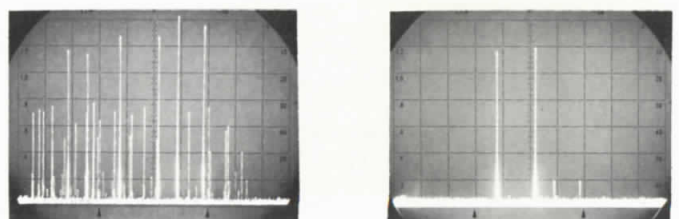

Figure 10. (a) Intermodulation Distortion Products (b) Reduction of Intermodulation Distortion

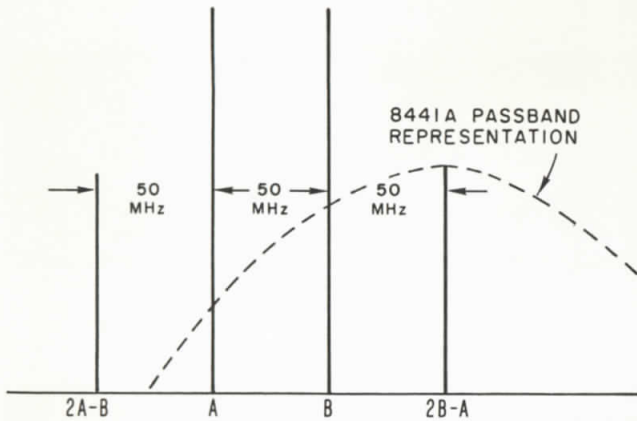

Figure 11. Intermodulation Distortion Reduction of Closely Spaced Signals

2. How can you automatically identify the input signal frequency?

The 8441A Preselector, when used with the 851B/852A/8551B Spectrum Analyzer, will track a selected analyzer mixing mode.

First, set the 8441A and the 8551 to the desired mixing mode; then tune the signal to the center of the 851 or 852 display. Now you can read the frequency directly from the corresponding 8551 frequency scale. This eliminates the need to use the signal identifier, as the preselector "preselects" the band of frequencies at which the analyzer will look.

3. How can you improve your analytic capability on broadband signals (frequency combs and very narrow pulses)?

Higher power signals must be reduced in the input attenuator so the spectrum analyzer mixer is not overdriven. (Mixer burnout will occur just over 1 mW.) With substantial attenuation, however, smaller signals are lost to the display.

This is especially significant when viewing broadband signals such as frequency combs from harmonic generators. Each spectral line contributes only a fraction of the total power to the mixer. In a broadband comb, each harmonic's contribution may be small, but the total power may be quite large, necessitating a large value of input attenuation. As a result, the displayed spectral lines have a poor signal-to-noise ratio, and any IF gain introduced will not affect this. Figure 12a shows the degraded signal-to-noise ratio.

The 8441A Preselector reduces the total power level to the analyzer mixer to just those spectral lines falling within its nominally 35 MHz passband. This is much lower than the total comb power, and allows the input attenuation and the IF gain to be reduced. Figure 12b illustrates the use of the preselector on the comb of Figure 12a, with the resultant increase in the effective signal-to-noise ratio.

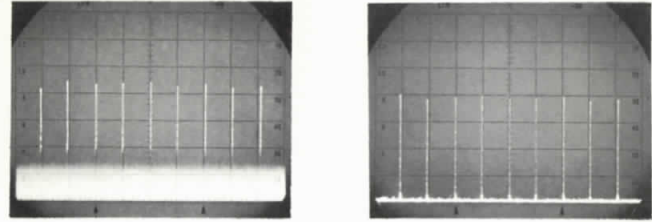

Figure 12. (a) Degraded Signal-to-Noise Ratio of Frequency Comb (b) Improved Signal-to-Noise Ratio with 8441A

4. How can you extend your effective distortion measurement capability with the 851B/852A/8551B by at least 30 dB?

Spurious signals in the 851B/852A/8551B are produced almost entirely by the nonlinear behavior of the input mixer. The level of these signals is typically more than 50 dB below the fundamental signal, as long as the total input power to the mixer is less than -30 dBm. Thus, the smallest distortion component (harmonic or IM) that can be measured is limited by the residual distortion of the analyzer. A simple test will determine whether or not a distortion component is internally generated:

- a. Increase the input attenuation by 10 dB and increase the IF gain 10 dB;
- b. If the amplitude of the distortion component is reduced, the distortion was internally generated.
- c. Continue this procedure until settings of the input attenuation and IF gain are found such that the signal level does not change further.
- d. Distortion on the display is now either the residual distortion of the analyzer (if the level is about -50 dB with respect to the fundamental) or distortion in the input signal (if the distortion component is significantly higher than the -50 dB level).

The effective dynamic range of the spectrum analyzer for distortion measurements is, then, approximately 50 dB. This range can be extended by the use of the 8441A Preselector. Obviously, an external device cannot decrease the distortion generated internally by the analyzer. The selective filtering action of the preselector can, however, effectively eliminate the effects of the analyzer's harmonic distortion. This may be explained as follows.

The spectrum analyzer sweeps through the selected frequency range (Spectrum Width) in a selected sweep time (10 ms/cm max). At some time during the sweep, the analyzer will be tuned to receive the fundamental component of the input signal. The preselector is also tuned to this frequency. Accordingly, this signal will be displayed on the CRT. At some other time during the sweep, the analyzer local oscillator will be tuned to receive the second harmonic of the input signal. The preselector is tuned to this frequency also. Any second harmonic distortion components in the input

signal will pass through the preselector into the analyzer mixer and be displayed on the CRT. The bandwidth of the preselector is sufficiently narrow, however, to reject the fundamental component of the input signal level. Typically, this rejection is at least 35 dB. Thus, the distortion components of the fundamental generated by the analyzer will be about 50 dB below this level, or about -85 dB with respect to the input signal level.

The amplitude of the displayed distortion component can now be at least 85 dB below the fundamental before the measurement is limited by the analyzer's residual distortion. In effect, the dynamic range of the analyzer for distortion measurements has been greatly increased. It is now possible to operate the analyzer at power levels closer to 1 mW (the maximum rated power) with relative freedom from the distortion otherwise caused by overloading the mixer.

In both measurements (fundamental signal and distortion component) the amplitude of the displayed signal depends on the amplitude of the input signal and the relative gain of the analyzer. The relative gain of the analyzer is the sum of the IF gain and the conversion loss of the mixer minus the input attenuation. For example, suppose the second harmonic content of a 5-GHz signal generator is to be measured. The fundamental component was displayed on the 851 LOG display as 0 dB with the following control settings:

- IF gain = 40 dB
- Attenuator = 20 dB
- Relative mixer conversion loss (fundamental mixing) = 0 dB (see Table 1)

As defined above, then, the analyzer relative gain is  $40 - 20 - 0 = 20$  dB. Mixer flatness and YIG flatness contribute to this and must be considered when making high accuracy measurements.

The second harmonic component (10 GHz) is then measured. This component is displayed on the 851 LOG display as -55 dB with the following control settings:

- IF gain = 60 dB
- Attenuator = 10 dB
- Relative mixer conversion loss (2nd harmonic mixing) = -10 dB (see Table 1).

The relative analyzer gain is then  $60 - 10 - 10 = 40$  dB. The level of the second harmonic signal component with respect to the fundamental is then the algebraic difference of the relative displayed amplitudes ( $-55 - (0) = -55$  dB) and the difference in analyzer relative gain ( $40 - 20 = +20$  dB). The level of the second harmonic is, therefore,  $-55 - 20 = -75$  dB. Thus, distortion has been measured which is 75 dB below the carrier, even though the analyzer mixer is contributing distortion as high as -50 dB below the carrier.

Table 1. Relative Conversion Loss for Various Mixer Modes

Frequency Response, Coaxial Input (includes mixer and RF attenuator response with attenuator setting  $\geq 10$  dB)

Frequency Range	Mixing Mode n*	IF	Relative Conversion Loss (approx)**
10.1 MHz to 1.8 GHz	1 <sup>-</sup>	2 GHz	0 dB
1.8 to 4.2 GHz	1 <sup>±</sup>	200 MHz	0 dB
2.2 to 4 GHz	2 <sup>-</sup>	2 GHz	-5 dB
4 to 6 GHz	1 <sup>+</sup>	2 GHz	-3 dB
6 to 8 GHz	3 <sup>-</sup>	2 GHz	-10 dB
8 to 10 GHz	2 <sup>+</sup>	2 GHz	-10 dB

\* n = LO harmonic.

\*\* The relative displayed amplitudes of equal-amplitude input signals for the various harmonic mixing modes.

**USING THE 8441A AS A PROGRAMMABLE, CONTINUOUSLY TUNEABLE BANDPASS FILTER FROM 1.8 TO 12.4 GHz**

1. How can you select the desired harmonic in frequency multiplier chains?

The YIG filter is tuned by an external voltage when in the external mode. Its voltage sensitivity is continuously variable from 0.1 to 4.5 MHz/mV. The zero voltage point can be offset to correspond to any desired frequency within the 1.8- to 12.4-GHz tuning range. With the voltage to frequency conversion established, a power supply can be programmed to introduce selected voltages into the YIG tuning circuits. The filter center frequency can be changed in less than 10 ms.

Figure 13a is an oscillogram of a frequency multiplier's harmonic frequency comb. Figure 13b shows the results of selecting various harmonics in the multiplier chain with the preselector. Harmonics only 10 MHz away from the desired frequency are between 25 and 35 dB below it.

2. How can you ensure low harmonic content from your sweep oscillator for greater broadband testing accuracy?

The 8690A Sweep Oscillator has a voltage proportional to RF frequency available at the sweep reference output. When this is connected to the preselector's external input, the 8441A's internal circuitry can be

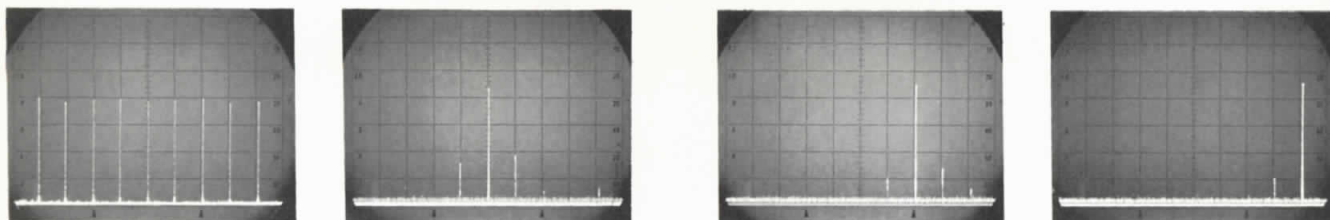

Figure 13. (a) Harmonic Frequency Comb (b) Selection of Harmonics from Comb with 8441A

simply adjusted to adapt the voltage to the requirements of the YIG. As the sweep oscillator tunes over any portion of its frequency band, the YIG will track it if the sweep rate does not exceed 20 MHz/ms. Any harmonics generated in the sweep oscillator will be reduced by at least 50 dB, resulting in increased spectral purity.

Figure 14a is an oscillogram of the spectral output of a typical sweep oscillator operating in the CW mode. When the 8441A Preselector is attached to the RF output, the harmonic content is substantially reduced. Figure 14b shows that the harmonics are reduced to the noise level of the system.

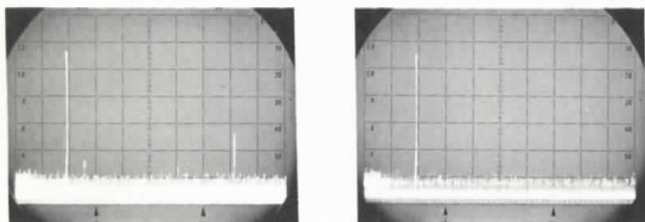

Figure 14. (a) Typical Sweep Oscillator Output in CW (b) Reduced Harmonic Content in Sweeper Output with 8441A

### USING THE 8441A PRESELECTOR AS AS A SIMPLE SPECTRUM ANALYZER

When internally swept, the 8441A Preselector plus a broadband crystal detector and a sensitive oscilloscope form a simple spectrum analyzer (see Figure 15). It acts as a receiver of the TRF (tuned radio frequency) variety. This, by definition, has no input mixer and therefore spurious signals cannot be produced. Further, there can be no harmonic responses. Although the display is not complicated by unwanted signals, the sensitivity is low. The wide sweep capability (1.8 to 12.4 GHz in a single sweep) is especially applicable to broadband spectrum density studies.

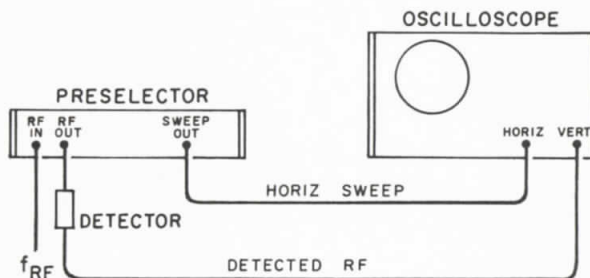

Figure 15. Simple Spectrum Analyzer of TRF Type