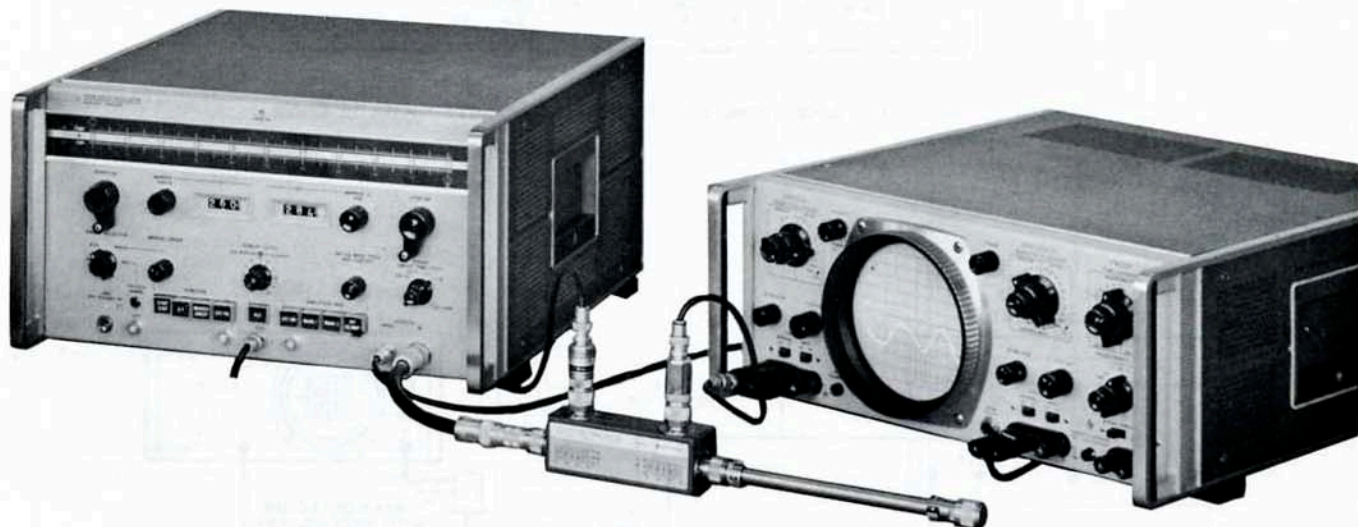

**LEVELLED SWEEP-FREQUENCY MEASUREMENTS WITH OSCILLOSCOPE DISPLAY**

Oscilloscope graticule scales furnished with this Application Note permit calibrated reflection and transmission measurements over broad frequency bands using  $\Phi$  690 series leveled sweep oscillators. You can now use an oscilloscope to provide a calibrated, immediate, and continuous display-with-frequency of transmission-loss or SWR, so that accurate on-the-spot adjustments to equipment can be made.

This Application Note shows how oscilloscope/sweep oscillator displays are set up. Full-size calibration scales for both transmission and reflection measurements are included. Crude grease-pencil calibration lines for the oscilloscope face or preliminary calibration plots made with a ratio meter and an X-Y recorder are no longer required.

Sweep oscillators and associated instruments are available for testing both coaxial and waveguide microwave components from 1 to 40 Gc. Such items as adapters, impedance transformers, tuners, loads, filters, detectors, couplers, and attenuators can be measured or adjusted. Swept-leveled techniques are also useful for overall system analysis.

Leveled sweep oscillators are not only helpful design aids, but can be used as maintenance tools as well. They will serve for fast routine maintenance checks on laboratory instruments. Figure 1A, for example, shows a reflection imperfection on an intermittently defective 2200-Mc low-pass filter. It was quickly detected and repaired after using leveled sweep-frequency techniques. Figure 1B gives the reflection

characteristics of the repaired filter. The filter defect (a faulty type "N" connector) could have gone unnoticed using point-by-point measurements. Hours, and sometimes days, of tedious precise measurements can often be completed within minutes.

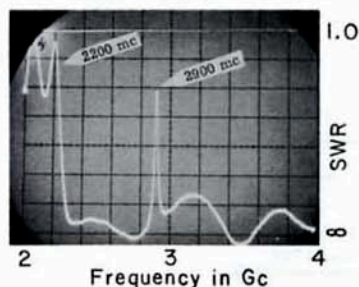

Figure 1A. Reflection from 2200-Mc Low-Pass Filter. Peak at 2900 Mc is from defective type N connector.

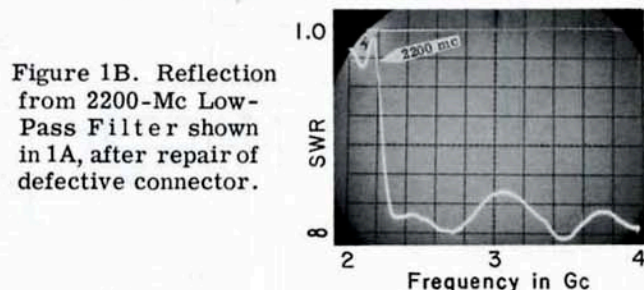

Figure 1B. Reflection from 2200-Mc Low-Pass Filter shown in 1A, after repair of defective connector.

**TRANSMISSION MEASUREMENTS**

Typical setups for making coaxial and waveguide transmission measurements are shown in Figures 2, 3, and 4. The forward-wave detected signal is applied to the sweep oscillator for leveling purposes.

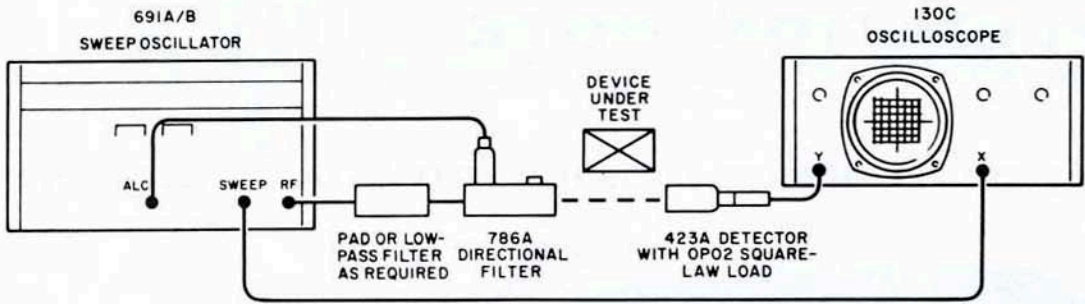

Figure 2. Setup for Low-Loss Transmission Measurements in Coax

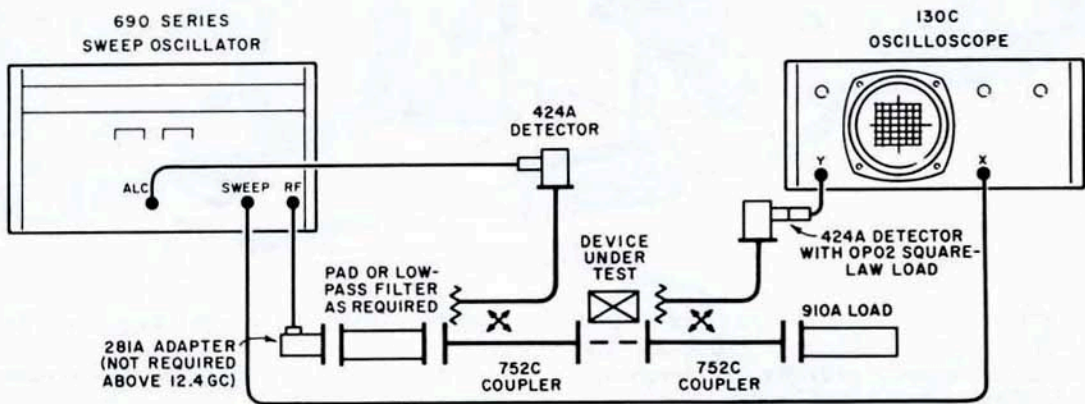
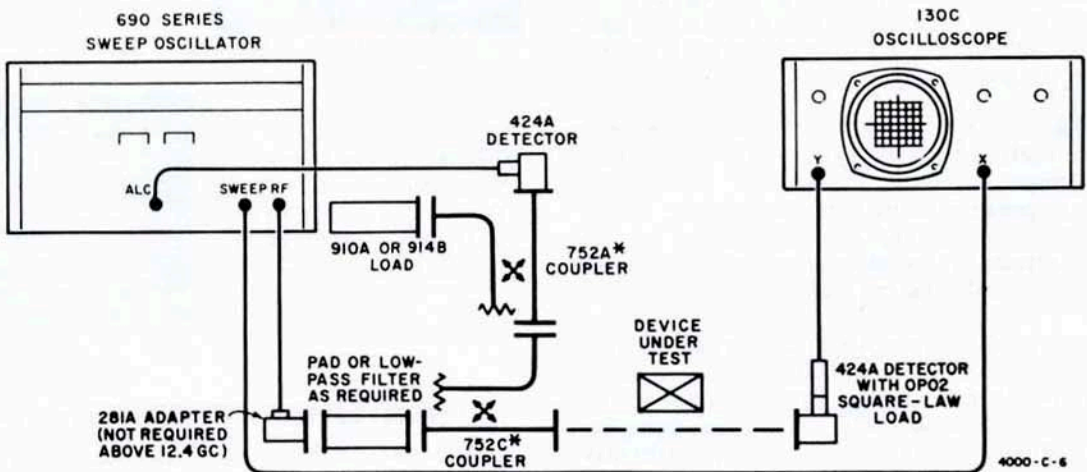

Figure 3. Setup for Low-Loss Transmission Measurements in Waveguide



\* COUPLER CURVES MUST BE MATCHED. ORDER E01-752C WHICH INCORPORATES THE TWO MATCHED COUPLERS AND A 910A OR 914B LOAD. SEE TABLE III FOR COMPLETE DETAILS.

Figure 4. Setup for High-Loss Transmission Measurements in Waveguide

For coaxial testing use the  $\Phi$  780 series Directional Detectors\* (shown in Figure 2) to complete the leveling-feedback-loop from RF to the sweep oscillator leveling amplifier. Frequency response of these devices for 1 to 2 and 2 to 4 Gc ranges is  $\pm 0.2$  db.

All  $\Phi$  752 series waveguide couplers have a RF frequency response of better than  $\pm 0.5$  db. To minimize this frequency error in making transmission measurements use the coupler curve matching setups shown in Figures 3 and 4. Figure 3 shows how the detected RF response of one coupler is used to adjust sweep oscillator leveling. This compensates for the detected RF response of the coupler driving the oscilloscope, if the two sets of coupler curves are identical. Frequency response curves of 752C couplers usually match within one or two tenths of a db. The 752C/424A system used as a detector presents a main guide SWR of 1.05 to the device under test and therefore reduces measurement mismatch error. The 424A Detectors have a response of  $\pm 0.2$  db through H band and  $\pm 0.3$  db in X band. The response of M and P band units is  $\pm 0.5$  db.

For making high-loss transmission measurements, Figure 4 shows an arrangement for removing coupler attenuation between the device under test and the detector-indicator. The result is a 10-db improvement in sensitivity over the Figure 3 setup. This system also employs coupler frequency response curve compensation, but needs the factory matched E01-752C arrangement in order to hold coupler matching limits within one or two tenths of a db. Knowing your measurement frequency range, select the proper sweep oscillator, directional coupler or directional detector, and other instruments from Table IV.

For the oscilloscope detectors shown in Figures 2, 3, or 4, always use the load resistor purchased under 423A or 424A Option 02, because detector and load have been optimized for square-law voltage response (linear power). The 423A or 424A used with its individually factory-mated load has a square-law response within  $\pm 1/2$  db below 50 mv DC output as measured on the oscilloscope. When square-law loading is required for the detector, use only the factory-supplied load furnished with each Option 02 detector. Identification is easy because load and detector bear identical serial numbers. The detector used for leveling need not be square-law loaded because under closed loop conditions, level always remains the same.

#### CALIBRATION PROCEDURE

With the instruments set up as shown in Figures 2, 3, or 4, connect coax or waveguide together, in place of device under test. Oscilloscope horizontal and vertical amplifiers should be set to respond to DC, and the vertical attenuator should be set to a convenient multiple or fraction of ten. Of course, the maximum power applied to the flat detector should be within the square-law range. Filters, pads, and adapters within the RF leveling loop will not affect the frequency response of the leveled RF output.

\* The directional detector combines directional coupler and microwave crystal detector thereby avoiding the SWR ambiguity of connecting the two instruments.

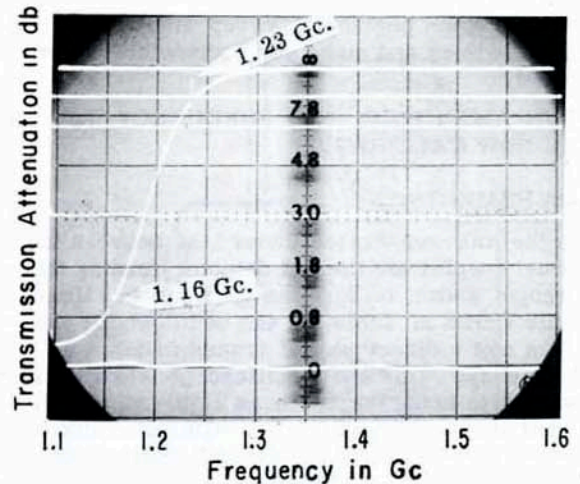

Figure 5. Shows 0, 3, 7, and 10 db Calibration Lines and the Insertion-Attenuation of a 1200-Mc Low-Pass Filter

#### With Sweep Oscillator Power Switch in "STANDBY".

- Cut transparent "db" scale from foil. Place scale on oscilloscope graticule as shown in Figure 5. Use either static charge or several small spots of rubber cement to hold scale in place.
- Adjust sweep oscillator frequency limits.
- Set oscilloscope horizontal gain control to give desired calibration in Gc/cm. The sweep oscillator sweep circuits must be operating for this adjustment.
- Set oscilloscope vertical position control to establish the base line on the CRT screen for  $\infty$  attenuation. For use with the "db" scale in Table III, the base line should be exactly 3 cm up from the CRT graticule center line.

#### With Sweep Oscillator Power Switch in "RF".

- Adjust sweep oscillator for leveled sweep as displayed on oscilloscope.
- Check flat detector for overloading. Detector output as measured on oscilloscope should not exceed 50 mv. If voltage is excessive, lower sweep oscillator output power or insert an appropriate pad between RF and detector.
- Set zero db calibration line exactly 3 cm down from CRT graticule center line, using oscilloscope vertical attenuator and vernier.
- Recheck zero and  $\infty$  db lines again as outlined under the previous steps. Also, be sure oscilloscope vertical DC balance is in proper adjustment so the base line calibration will not change with various oscilloscope attenuator settings.

- Using sweep oscillator marker controls, check linearity of your horizontal sweep at major vertical graticule lines and make any horizontal adjustments needed.

YOUR AMPLITUDE AND FREQUENCY SCALES ARE NOW CALIBRATED.

### MEASUREMENTS

Place the unknown device under test between the directional coupler and the flat detector (feeding the oscilloscope) shown in Figures 2, 3, or 4. Using the db scale shown in Table III, the oscilloscope presentation is now a direct plot of transmission loss in db vs frequency. Use the oscilloscope vertical step-attenuator to bring the trace as close as possible to (but still above) the lower 3-cm calibration line, without changing the vernier or vertical position controls. Note the ratio of steps traversed on the attenuator, and from Table I add the related number of db to the calibrated oscilloscope scale reading.

Table I. Oscilloscope Scale Correction with Attenuator Setting

Attenuator Voltage Ratio	DB Correction*
1.0	0
.5	3
.2	7
.1	10
.05	13
.02	17
.01	20

\* Add this number to transmission attenuation.

Attenuator settings, of course, can be extended beyond those shown in Table I using the same system of correction. If more vertical amplifier gain is needed, use the 140A Oscilloscope with 1400A and 1420A Plug-In Units. The photo shown in Figure 5 is an oscilloscope picture of a 1200-Mc coaxial low-pass filter response complete with vertical attenuator calibration lines. The setup of Figure 2 was used for this picture; arrows show sweep oscillator marker pips for exact calibration. A high degree of accuracy can be attained on both frequency and amplitude axes. Note the trace-splitting precision with which amplitude and frequency calibration lines fall on the graticule in the example given.

It is reasonable to expect similar performance in day-to-day service with truly square-law/frequency-flat detectors, with the sweep oscillator well leveled, with a modern internal-graticule oscilloscope, and with stable circuitry throughout the system. The  $\text{hp}$  instruments shown in Table IV, when connected as shown in Figures 2, 3, or 4, incorporate all these features.

### REFLECTION MEASUREMENTS

Probably one of the most useful functions of a leveled sweep oscillator is in making rapid accurate reflection measurements. Typical leveled reflectometer setups for coaxial and waveguide testing are shown in Figures 6 and 7. The forward-detected signal is used to level

the sweep oscillator. The detected signal reflected from the device under test is displayed on the oscilloscope which is calibrated in SWR vs frequency. The unknown load on which the reflection measurements are being made is used as a termination on the through arm of the coupler system, opposite the end fed by the leveled sweep oscillator.

For coaxial testing, use the  $\text{hp}$  770 series Dual Directional Couplers shown in Figure 6. Coupler arm frequency response is specified not more than  $\pm 1$  db. However, if the response of forward and reverse arms match, the sweep oscillator will be leveled to the forward arm response curve in a manner that will compensate for reverse-arm response. Typical forward and reverse arm frequency-response matching for these devices in the 1 to 2 and 2 to 4 Gc range is better than  $\pm 0.2$  db.

For waveguide testing, two 752 directional couplers can be placed together to form a waveguide reflectometer. Waveguide coupler matching, as in dual coaxial-coupler arm-matching, uses the forward-arm response to compensate for reverse-arm response. Coupler-arm frequency-response matching for the 752C arrangement shown in Figure 7 is usually within one or two tenths of a db. Knowing your measurement frequency range, select the proper sweep oscillator and directional coupler from Table IV.

Always use the square-law load resistor purchased under Option 02 for loading 423A or 424A detectors as indicated in the previous section on transmission measurements. Detector DC output should be held below 50 mv.

### CALIBRATION PROCEDURE

With the instrument set up as shown in either Figure 6 or 7, oscilloscope horizontal and vertical amplifiers should be set to respond to DC, and the vertical attenuator should be set to a convenient multiple or fraction of ten. Power applied to the flat detector driving the oscilloscope should be within the square-law range. Filters, pads, and adapters within the RF leveling loop will not affect the frequency response of the leveled RF output.

Be sure reflectometer coupler directivity is high enough so that unwanted forward signals do not interfere with reflected signals. Table II shows the minimum quality of coupler directivity required for measuring reflections. The higher the coupler directivity above the minimum value, the lower the area of measurement ambiguity.

Table II. Coupler Directivity Required for Measuring a Given SWR

SWR Measured	Coupler Directivity Required
> 1.10	> 30
> 1.05	> 35
> 1.03	> 40

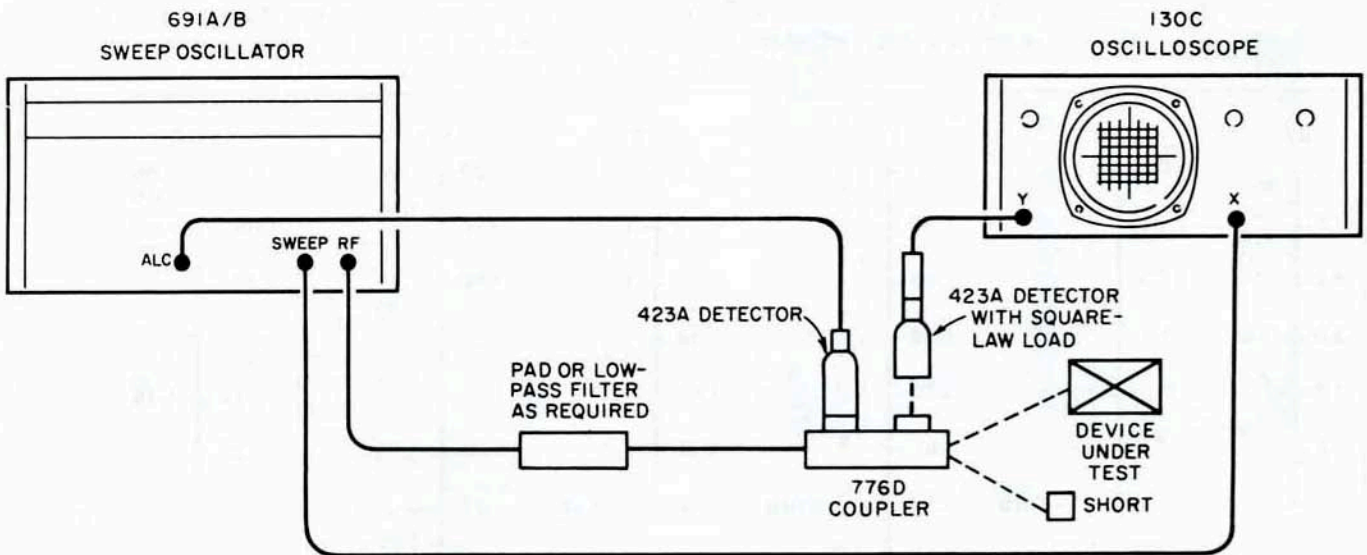

Figure 6. Setup for Reflection Measurements in Coax

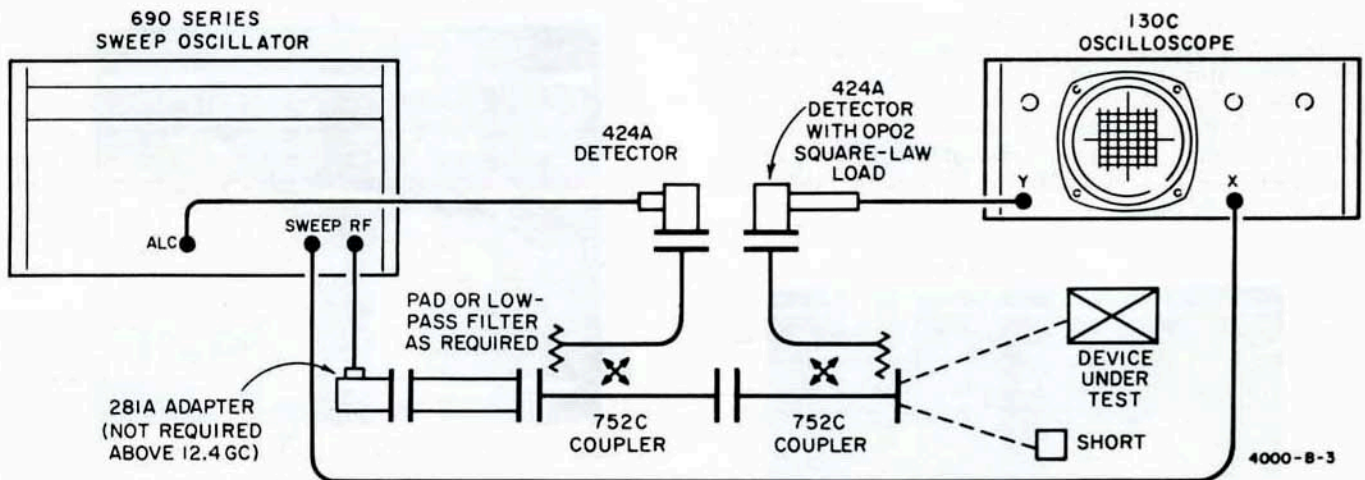

Figure 7. Setup for Reflection Measurements in Waveguide

With Sweep Oscillator Power Switch in "STANDBY".

- Adjust sweep oscillator frequency limits.
- Set oscilloscope horizontal gain control to give the desired calibration in Gc/cm. The sweep oscillator sweep circuits must be operating for this adjustment.
- For use with "SWR" scales shown in Table III, set the oscilloscope vertical position control to establish the CRT trace exactly 3 cm up from the graticule center line. This corresponds to 1.00 on all SWR scales.

With Sweep Oscillator Power Switch in "RF".

- Place short on reflectometer.
- Adjust sweep oscillator for leveled sweep as displayed on oscilloscope.
- For use with SWR scales shown in Table III, set oscilloscope vertical attenuator and vernier controls

to establish CRT trace exactly 3 cm below graticule center line. This corresponds to  $\infty$  on SWR scale and 0 db return loss on db scale.

- Remove short from reflectometer and with system open-circuited, observe  $\infty$ -SWR-reflection/0-db return-loss-line on face of CRT. Phase reversal will be about 180°, but amplitude deviation should be about the same. If a substantial difference exists between the calibration lines obtained with the short and the open, there is a fault in the measurement system which should be corrected. For return loss differences of less than  $\pm 1/2$  db use a calibration setting halfway between the "short" and "open" trace lines.

**YOUR AMPLITUDE AND FREQUENCY SCALES ARE NOW CALIBRATED FOR MEASURING REFLECTION IN SWR.**

Table III. Examples of Transmission and Reflection Scales for Use on Cathode-Ray Tube Graticule. Use transparent plastic or white-paper inserts provided with this Application Note for calibration of CRT face.

<p>db</p> <p>∞</p> <p>16</p> <p>10</p> <p>7.8</p> <p>7.0</p> <p>6.0</p> <p>4.8</p> <p>4.0</p> <p>3.0</p> <p>3.0</p> <p>2.0</p> <p>1.8</p> <p>1.0</p> <p>0.8</p> <p>1.0</p> <p>0</p> <p>0</p>	<p>SWR</p> <p>1.00</p> <p>1</p> <p>2</p> <p>2.38</p> <p>3</p> <p>3.73</p> <p>4</p> <p>5</p> <p>5.8</p> <p>8</p> <p>10</p> <p>9.9</p> <p>20</p> <p>22</p> <p>∞</p> <p>∞ -- 0db</p>	<p>SWR</p> <p>1.00</p> <p>1.0</p> <p>1.1</p> <p>1.2</p> <p>1.3</p> <p>1.4</p> <p>1.45</p> <p>1.5</p> <p>1.58</p> <p>1.6</p> <p>1.7</p> <p>1.70</p> <p>1.8</p> <p>1.81</p> <p>1.8</p> <p>1.93</p> <p>1.9</p> <p>10db</p> <p>2.04</p> <p>2.0</p>	<p>SWR</p> <p>1.00</p> <p>1.0</p> <p>1.20</p> <p>1.2</p> <p>1.30</p> <p>1.3</p> <p>1.38</p> <p>1.4</p> <p>1.45</p> <p>1.5</p> <p>1.51</p> <p>1.5</p> <p>1.58</p> <p>13db</p>	<p>SWR</p> <p>1.00</p> <p>1.00</p> <p>1.12</p> <p>1.10</p> <p>1.15</p> <p>1.18</p> <p>1.20</p> <p>1.22</p> <p>1.20</p> <p>1.25</p> <p>1.26</p> <p>1.30</p> <p>1.30</p> <p>1.33</p> <p>1.35</p> <p>17db</p>	<p>SWR</p> <p>1.00</p> <p>1.00</p> <p>1.05</p> <p>1.08</p> <p>1.10</p> <p>1.122</p> <p>1.15</p> <p>1.152</p> <p>1.15</p> <p>1.18</p> <p>1.18</p> <p>1.20</p> <p>1.20</p> <p>1.22</p> <p>1.22</p> <p>20db</p>
--	---	--	--	--	--

**MEASUREMENTS**

Place the unknown device under test as a termination on the reflectometer. Change the oscilloscope vertical step-attenuator setting to bring the trace as close as possible to (but still above) the lower 3-cm calibration line, without changing the vernier or vertical position controls. If more vertical amplifier gain is required, use the 140A Oscilloscope with 1400A and 1420A Plug-In Units.

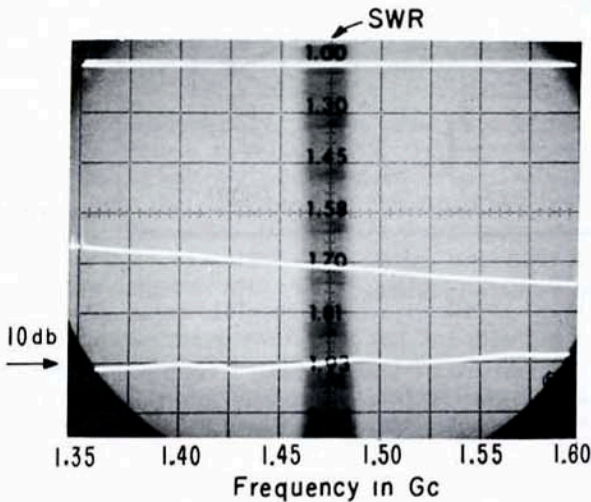

Figure 8. Reflection from Coaxial Crystal Detector Mount (older style)

Note the number of steps traversed by the step-attenuator and from Table I relate to return-loss in db. Knowing return-loss, select the matching SWR scale from Table III. Full scale (6 cm) return-loss is marked on each SWR scale. Cut the proper transparent "SWR" scale from the foil. Place scale on oscilloscope graticule as shown in Figures 8 and 9. Use either static charge or several small spots of rubber cement to hold scale in place. The thus selected reflection scale gives an accurate calibration of SWR on the CRT face.

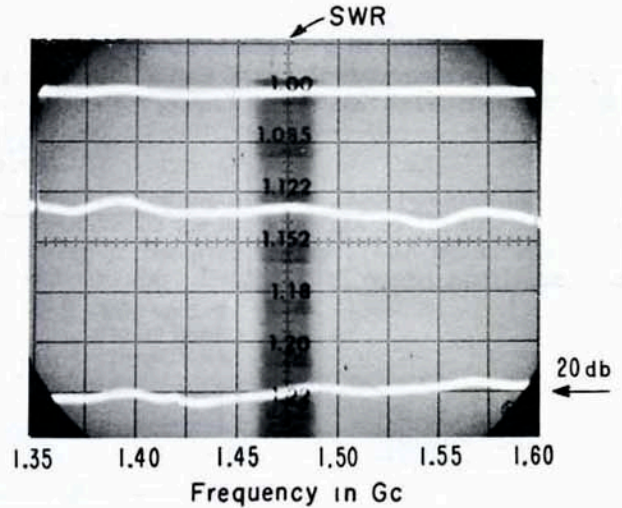

Figure 9. Reflection from New Flat-Response 423A Coaxial Crystal Detector Mount (note low SWR)

The examples shown in Figures 8 and 9 display sweep reflection measurements for two coaxial crystal detector mounts. The older mount design measurement shown in Figure 8 indicates a SWR of 1.65 to 1.75, with a 10-db return-loss line. Measurement on the mount of newer design shown in Figure 9 indicates a SWR of 1.14 to 1.15, with a 20-db return-loss reference.

**RECOMMENDED INSTRUMENTS**

Both coaxial and waveguide instruments for leveled swept frequency measurements are shown in Table IV. Attenuators for making insertion and return-loss calibrations are indicated. Hewlett-Packard sweep oscillators and other instruments shown give complete coverage from 1 to 40 Gc.

Table IV. Recommended Instruments for Leveled Swept-Frequency Measurements<sup>1</sup>

INSTRUMENT	1 to 2 Gc	2 to 4 Gc	4 to 8 Gc	8 to 12.4 Gc	12.4 to 18 Gc	18 to 26.5 Gc*	26.5 to 40 Gc*
<b>Major Instruments</b>							
Sweep Oscillator	691A/B <sup>3</sup>	692A/B <sup>3</sup>	693A <sup>3</sup>	694A <sup>3</sup>	695A <sup>4</sup>	696A <sup>4</sup>	697A <sup>4</sup>
Oscilloscope	130C	130C	130C	130C	130C	130C	130C
Plug-In Oscilloscope	140A	140A	140A	140A	140A	140A	140A
High Sensitivity Vertical Plug-In	1400A	1400A	1400A	1400A	1400A	1400A	1400A
Horizontal Sweep	1420A	1420A	1420A	1420A	1420A	1420A	1420A
<b>Coaxial Instruments<sup>3</sup></b>							
Dual Directional Coupler	776D	777D					
Single Directional Coupler	796D	797D					
Directional Detector	786D	787D					
Crystal Detector	423A	423A					
Crystal Detector and Square-Law Load	423A Op 02	423A Op 02					
Low-Pass Filter	360C	360D					
Male Shorting Plug	11512A	11512A					
Female Shorting Jack	11511A	11511A					
50-Ohm Termination	908A	908A					
50-Ohm Sliding Termination	906A	906A					
3-db Attenuator <sup>2</sup>	650-3	650-3					
10-db Attenuator <sup>2</sup>	650-10	650-10					
20-db Attenuator <sup>2</sup>	650-20	650-20					
<b>Waveguide Instruments<sup>4</sup></b>							
Flat Directional Coupler (13 db)	← E01-752C <sup>5</sup> (S, G, J, H, X, M, P, K & R bands) →						
Flat Directional Coupler (23 db)	← E02-752D <sup>6</sup> (S, G, J, H, X, M, P, K & R bands) →						
Directional Coupler (3 db)	← 752A (S, G, J, H, X, M, P, K & R bands) →						
Directional Coupler (10 db)	← 752C (S, G, J, H, X, M, P, K & R bands) →						
Directional Coupler (20 db)	← 752D (S, G, J, H, X, M, P, K & R bands) →						
Crystal Detector	← 424A (S, G, J, H, X, M, & P bands) →					← 422A <sup>7</sup> (K & R bands) →	
Crystal Detector (Sq-Law Load)	← 424A with Op 02 (S, G, J, H, X, M & P bands) →					← 422A <sup>7</sup> (K & R bands) →	
Coax-to-Waveguide Adapter	← 281A (S, G, J, H & X bands) →						
Low-Pass Filter	← 362A (X, M, P, N, K & R bands) →						
Adjustable Short	← 920A (S, G, J, H, X & M bands) →			← 920B (P, K & R bands) →			
Termination	← 910A (S, G, J, H, X & P bands) →						
Sliding Termination	← 914A (S, G, J, H, X, M & P bands) →					← 914B (K & R bands) →	
Fixed Attenuator (10 db)	← 372C (S, G, J, H, X, P, K & R bands) →						
Fixed Attenuator (20 db)	← 372D (S, G, J, H, X, P, K & R bands) →						
Variable Precision Attenuator	← S382B/C → ← 382A (G, J, H, X, M, P, K & R bands) →						
Waveguide Adapters	← 292B (HX, MX & JP bands) 292A (NP & NK bands) →						

<sup>1</sup> Hewlett-Packard instruments unless otherwise specified

<sup>2</sup> Weinschel Engineering

<sup>3</sup> Type "N" coaxial RF connectors

<sup>4</sup> Waveguide flange-type RF connectors

<sup>5</sup> Includes matched 752A and 752C plus a 910 Termination. K & R bands will be supplied with 914B Termination.

<sup>6</sup> Includes matched 752A and 752D plus a 910 Termination. K & R bands will be supplied with 914B Termination.

<sup>7</sup> Order Option 01 for frequency response tracking ±1 db.

\* K & R band units supplied with rectangular flanges. For circular flange adapters order 11515A for K band and 11516A for R band.

**Waveguide Bands**

S = 2.60 - 3.95 Gc	M = 10 - 15 Gc
G = 3.95 - 5.856 Gc	P = 12.4 - 18.0 Gc
J = 5.3 - 8.2 Gc	N = 15 - 22.0 Gc
H = 7.05 - 10.0 Gc	K = 18 - 26.5 Gc
X = 8.2 - 12.4 Gc	R = 26.5 - 40 Gc

**TRANSMISSION AND REFLECTION SCALES**  
for  
**VISUAL OBSERVATION OF TRACES ON 6 CM CATHODE RAY TUBE GRATICULE**

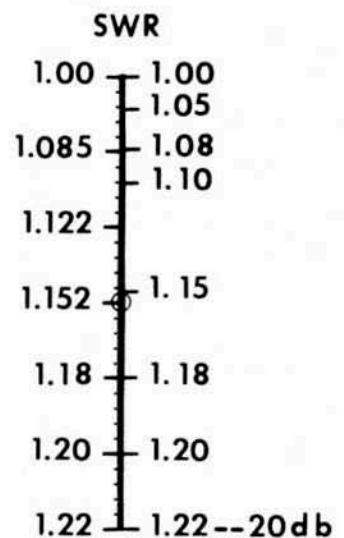
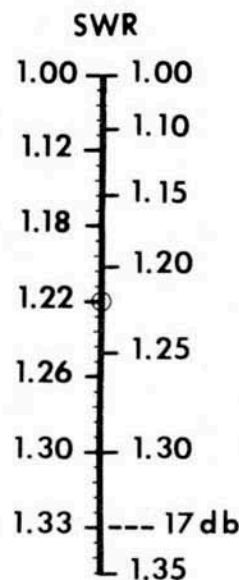
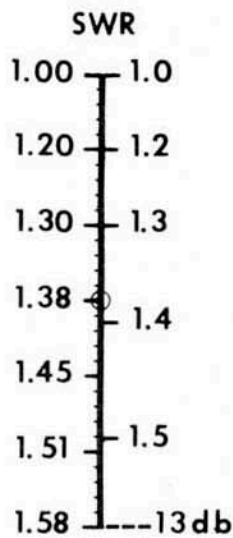
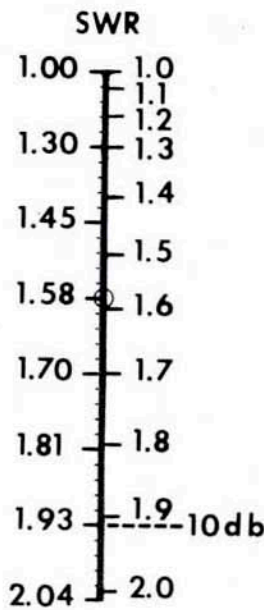
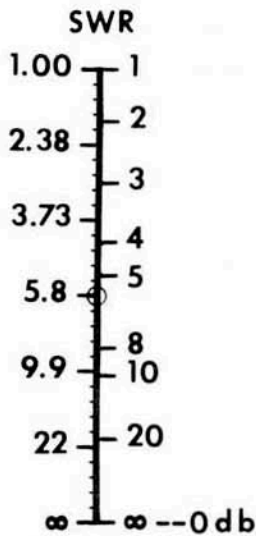
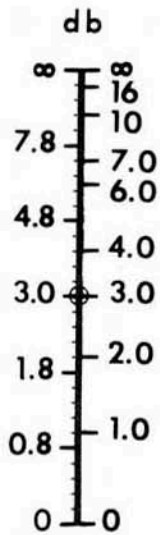

**Instructions:**

- 1 - For use with leveled sweep oscillator and flat square-law detector.
- 2 - Cut desired scale and fasten to edge of CRT graticule with several small spots of rubber cement.
- 3 - White paper scales are 1:1 for visual observation and do not have parallax correction for camera work.
- 4 - Use in accordance with Application Note 61.

# HEWLETT-PACKARD SALES AND SERVICE OFFICES IN NORTH AMERICA

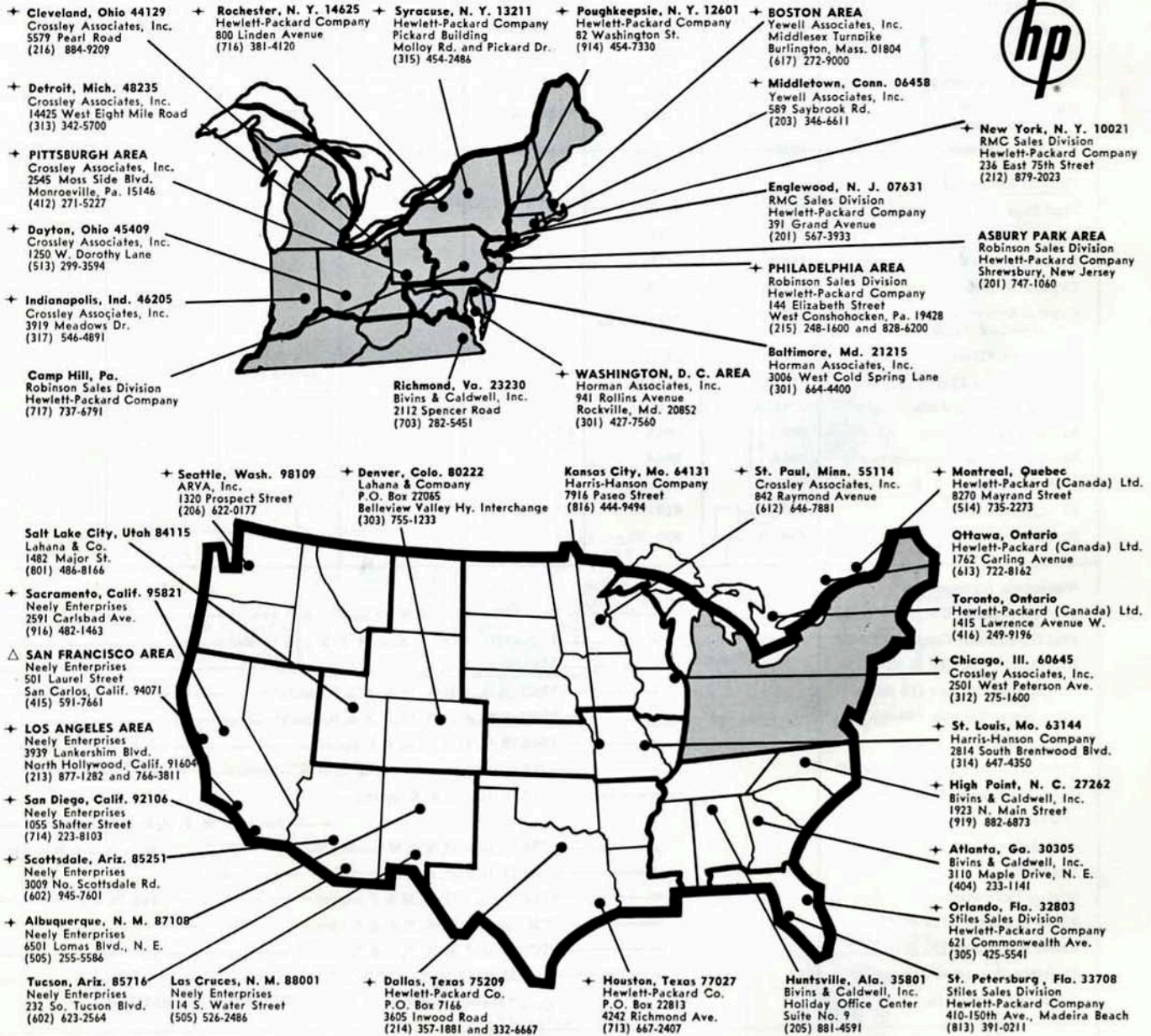

△ For replacement parts and repair services in the San Francisco area, please contact Hewlett-Packard Company, 395 Page Mill Road, Palo Alto, California, Tel: (415) 326-3950.  
+ Indicates Instrument Repair Stations.

## HEWLETT-PACKARD COMPANY

1501 Page Mill Road • Palo Alto, California 94304  
Tel: (415) 326-7000 • TWX: 415-492-9200 • Cable: HEWPACK

## DYMEC DIVISION

395 Page Mill Road • Palo Alto, California 94306  
Tel: (415) 326-1755 • TWX: 415-492-9363

## BOONTON RADIO COMPANY

Green Pond Road • Rockaway, New Jersey 07866  
Tel: (201) 627-6400 • Cable: BOONRACO

## HARRISON LABORATORIES

41 Industrial Road • Berkeley Heights, N. J. 07922  
Tel: (201) 464-1234 • TWX: Summit, N. J.

## SANBORN COMPANY

175 Wyman St., Waltham, Mass. 02154  
Tel: (617) 894-6300 • TWX: 617-894-0789

## F. L. MOSELEY CO.

409 N. Fair Oaks Ave. • Pasadena, Calif. 91102 • Tel: (213) 681-0208 • TWX: PASA CAL 7687 • Cable: MOCOPAS