



TRANSMISSION LINE TESTING USING THE SAMPLING OSCILLOSCOPE

I. INTRODUCTION

Conventional techniques for measuring characteristic impedance of transmission lines are quite involved. Several measurements must be taken, which, together with the assumptions made, severely limit the accuracy which can be obtained.

With the present availability of sampling oscilloscopes having rise times measured in fractional nanoseconds, extremely wide dynamic range, and horizontal sweep speeds approaching the velocity of propagation, a pulse-reflection technique can be used to give a direct reading of characteristic impedance. The impedance of lines as short as one foot may be measured to a few tenths of an ohm without involving normal connector discontinuities. In addition, the uniformity of characteristic impedance along the length of the line may be studied. Such information as the position and type of reactive discontinuities, the relative attenuation between cables, and the velocity of propagation may also be determined.

Before describing this system, it would be well to briefly review transmission line theory.

II. PROPAGATION ON A TRANSMISSION LINE

The Classical transmission line is assumed to be made up of continuous series of R's, L's and C's, as shown in figure 1. By studying this low frequency equivalent circuit, several characteristics of the transmission line can be determined.

If the line is infinitely long and L, R, G and C are defined per unit length, then

$$Z_{in} = \sqrt{\frac{R + j\omega L}{G + j\omega C}} = Z_0$$

where Z_0 is the characteristic impedance of the line.

A voltage introduced at the generator will require a finite time to travel down the line to a point x. The phase of the voltage moving down the line will lag behind the voltage introduced at the generator by an amount β per unit length. Furthermore, the voltage will be attenuated by an amount α per unit length by the series resistance and shunt conductance of the line. The phase shift and attenuation are defined by the propagation constant γ , where

$$\gamma = \alpha + j\beta = \sqrt{(R + j\omega L)(G + j\omega C)}$$

α = attenuation in nepers per unit length
 β = phase shift in radians per unit length

The velocity at which the voltage travels down the line can also be defined in terms of β , as $v_p = \frac{\omega}{\beta}$ unit lengths per second.

The velocity of propagation approaches the speed of light, v_c , for transmission lines with air dielectric. For the general case

$$v_p = \frac{v_c}{\sqrt{k}}$$

where k is the dielectric constant.

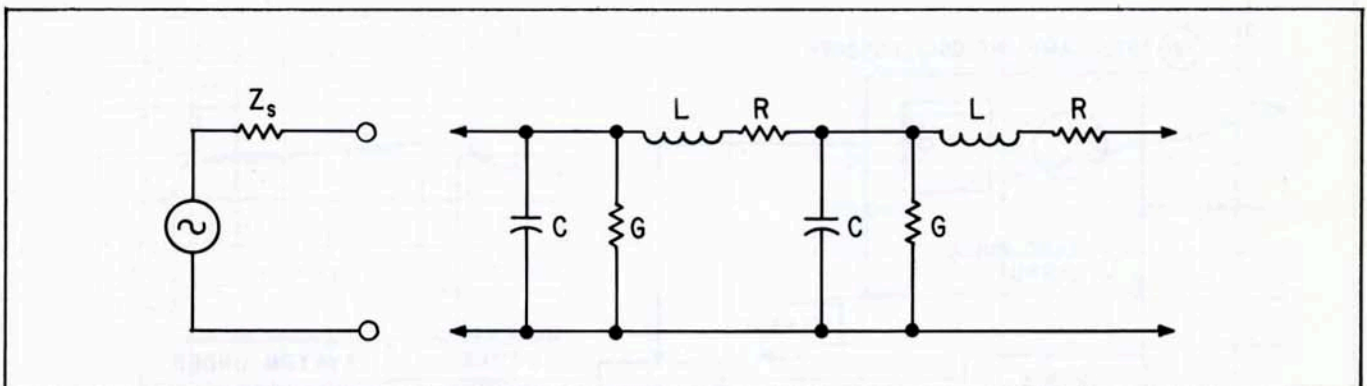

Figure 1. The classical transmission line

01112-2



The propagation constant γ can be used to define the voltage and the current at any distance x down the line by the relations

$$E_x = E_{in} e^{-\gamma x} \text{ and } I_x = I_{in} e^{-\gamma x}$$

Since the voltage at any point is related to the current by the characteristic impedance of the line

$$Z_0 = \frac{E_{in} e^{-\gamma x}}{I_{in} e^{-\gamma x}}$$

When the transmission line is finite in length and is terminated in a load whose impedance matches the characteristic impedance of the line, the voltage and current relationships are satisfied by the above equations.

If, on the other hand, the load is different from Z_0 , these equations are not satisfied unless a second wave is considered to originate at the load and to propagate down the line toward the source. This reflected wave is energy that is not delivered to the load. Therefore, the quality of the transmission system is indicated by the ratio of this reflected wave to the incident wave originating at the source. This ratio is called the voltage reflection coefficient, ρ_v , and is related to the transmission line impedance by the equation

$$\rho_v = \frac{Z_L - Z_0}{Z_L + Z_0}$$

Examining the voltage along a line terminated in a load other than Z_0 , it is found to vary periodically between a maximum and minimum value. This variation, called a standing wave, is caused by the phase relationship between incident and reflected waves. The ratio between the maximum and minimum values of this voltage is called the voltage standing wave ratio σ , and is related to the reflection coefficient by the equation

$$\sigma = \frac{E_{max}}{E_{min}} = \frac{1 + |\rho_v|}{1 - |\rho_v|}$$

Either of the above coefficients can be measured with presently available test equipment. But the value of these measurements to the design engineer is limited. For example, if a system consists of a connector, a short transmission line and a load, the measured reflection coefficient at the input indicates only the overall quality of the system. It does not tell which of the system components is causing reflection. It does not tell if the reflection from one component is of such a phase as to cancel the reflection from another.

Thus the measure of quality is good for only the one frequency at which the reflection coefficient is measured. The engineer must make measurements at many frequencies and probably with several techniques before he can know what must be done to improve the system.

III. PULSE REFLECTION TESTING

The introduction of a high frequency high sensitivity sampling oscilloscope has made a simpler and more meaningful technique available for testing transmission line systems. Figure 2 shows the test setup for making these measurements.

A fast rise-time step of voltage is launched down the transmission system. When the step encounters a discontinuity, some of the voltage is reflected back. This reflection is measured with the oscilloscope. Since propagation along the system requires finite time, discontinuities which are separated in space produce reflections which are separated in time. Thus, each discontinuity in the system can be identified separately on the oscilloscope. In addition, the exact location of the discontinuity, and whether it is resistive, capacitive, or inductive can be determined. All of this information is available at a glance and is independent of frequency, within the resolving power of the oscilloscope and the pulse.*

* The following photographs of oscilloscope traces were taken with an Φ Model 196A Oscilloscope Camera using Polaroid Land Type 47 film (speed 3000).

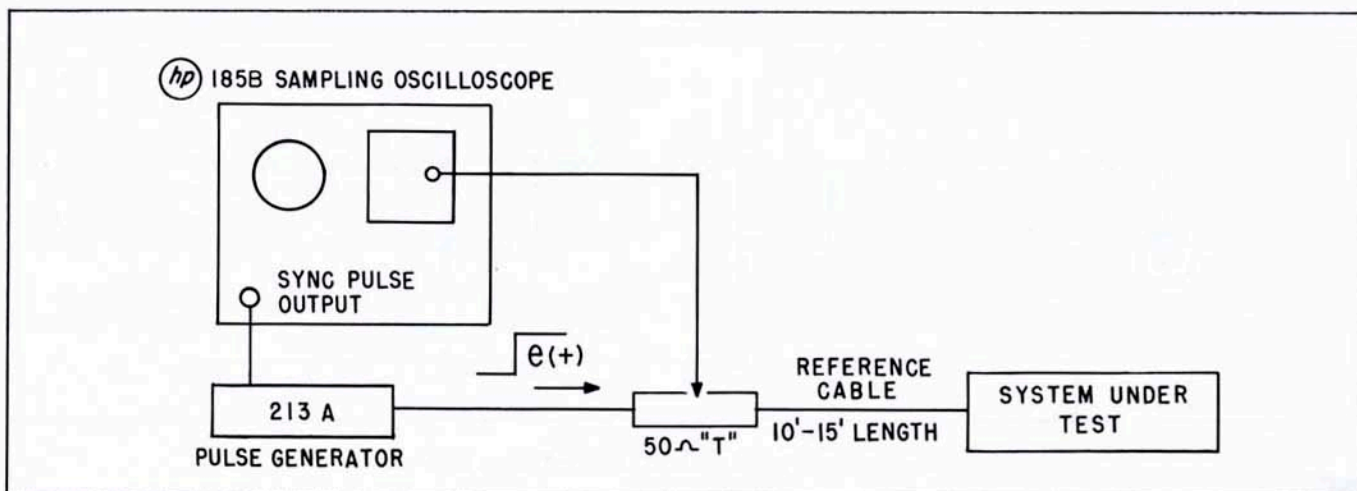

Figure 2. Test setup for using the Φ 185B Sampling Oscilloscope to check transmission systems

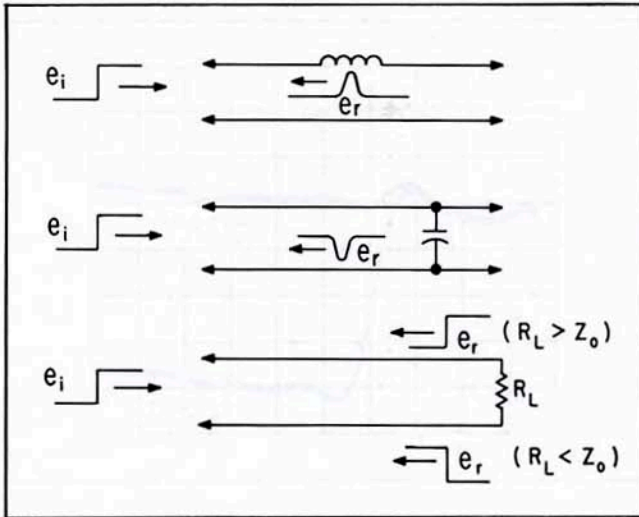

Figure 3. Reflections obtained from inductive, capacitive, and resistive discontinuities

Reflection Identification - Figure 3 shows the types of reflection obtained from different discontinuities. A small inductive discontinuity produces a reflection which is the positive differential of the step. The reflection from a small capacitive discontinuity is the negative differential of the step. A resistive discontinuity reflects a positive step for $R > Z_0$ and a negative step for $R < Z_0$.

Figures 4A and 4B show the actual reflections from inductive and capacitive discontinuities.

The incident voltage step contains frequencies up to approximately $0.35/t_r$ gigacycles, where t_r is the rise time in nanoseconds (10^{-9} seconds). Determining the exact magnitude of these frequencies would require careful analysis of the voltage step. The amount of each of these frequencies reflected from a specific

reactive discontinuity would also take careful analysis. As a result, it is not easy to relate the magnitude of the reflection from a reactive discontinuity to the exact value of the discontinuity. Much meaningful data can be obtained, however, by comparing the reflection from the discontinuity under test to that from a known discontinuity.

A reactive discontinuity for calibrating the oscilloscope may be created using the Model 872A Coaxial Slide-Screw Tuner. Initially, the vswr caused by various degrees of 872A probe insertion is measured for several frequencies, using a Model 805 Series Slotted Line. (In determining the vswr due to only the slide-screw tuner probe, it is moved along the line rather than the slotted line probe.) A calibration chart is constructed showing micrometer (probe depth) settings vs vswr for several frequencies. The slide-screw tuner is then viewed with the sampling oscilloscope system, with the known discontinuities being introduced and the magnitude of reflection being recorded. From this data a graph relating magnitude of reflection vs vswr or reflection coefficient may be drawn. (See figure 5.)

When the discontinuity is resistive and independent of frequency, an exact measurement can be made. Figure 6 shows the reflections from several type N loads whose resistances have been measured at dc. Using these loads, the oscilloscope vertical sensitivity has been calibrated to equal 1 ohm per centimeter. This measurement was used to calibrate the characteristic impedance of the reference cable at 49.8 ohms.

Figure 7 shows a comparison of a 49.9-ohm load and a 49.2-ohm load with the oscilloscope at maximum sensitivity. This results in a calibration of about 0.2 ohms per centimeter. The vertical calibration

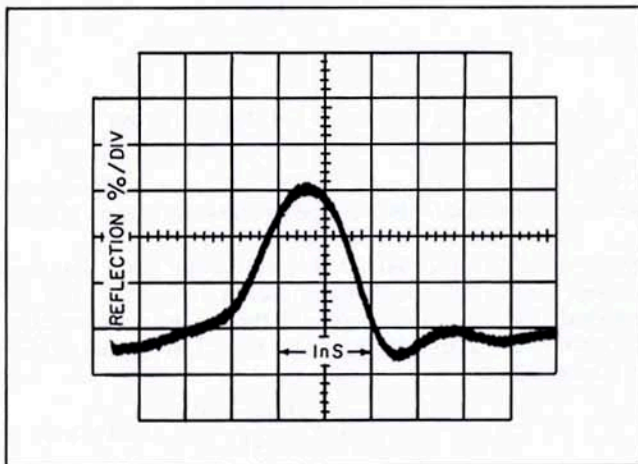

Figure 4(A). Inductive reflection from a type N load incompletely secured to the reference cable

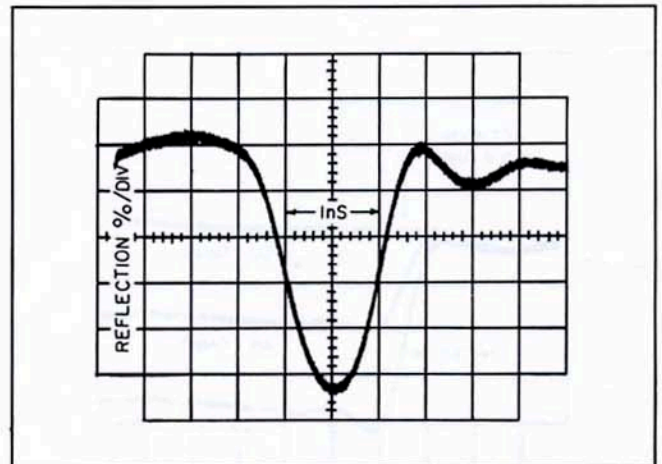

Figure 4(B). Capacitive reflection from a BNC "T" connected between the reference cable and a 50-ohm BNC load

will be linear as long as $Z_L \approx Z_0$. When this assumption is no longer valid, the exact expression

$$\rho_v = \frac{Z_L - Z_0}{Z_L + Z_0}$$

should be used. This may be solved for Z_L to give

$$Z_L = Z_0 \frac{(1 + \rho_v)}{(1 - \rho_v)}$$

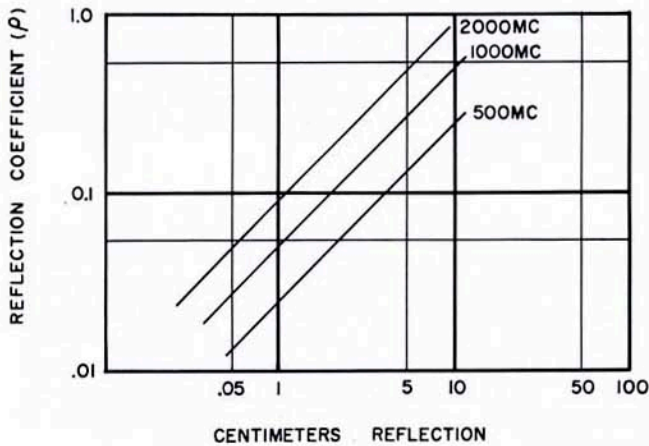

Figure 5. Example of graph relating magnitude of reflection to reflection coefficient for calibrating the oscilloscope (1 ohm per centimeter calibration)

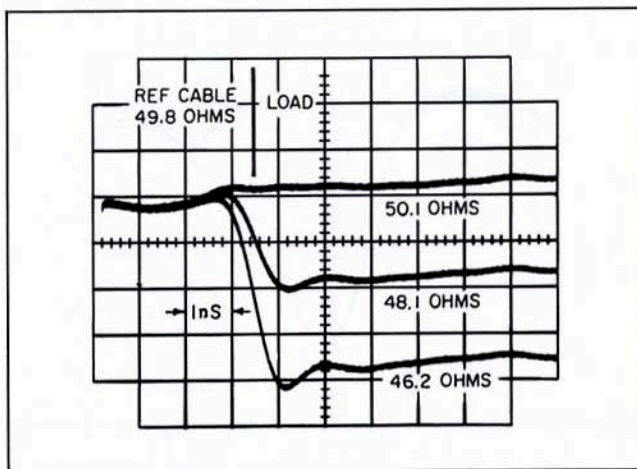

Figure 6. Resistive reflection from three type N loads. The reference cable Z_0 is 49.8 ohms.

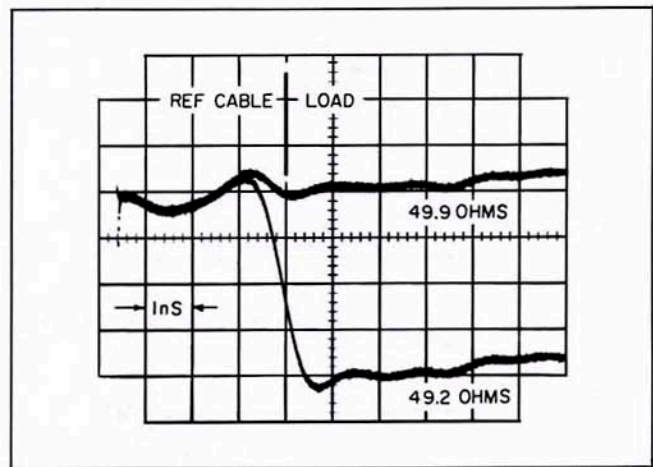

Figure 7. Maximum sensitivity of the 185B oscilloscope using the sync pulse output from the 185B as a source

Check Characteristic Impedance and Uniformity -

Figure 8 shows some examples of this technique when used to check the characteristic impedance and uniformity of both short and long coaxial cables. As can be seen in figure 8(B), large reactive discontinuities at the connectors of the cable do not affect the accuracy of the measurement.

Figure 9 compares two long coaxial cables. Both are RG-223/U, but are made by different manufacturers. The gradual upward slope of the impedance shown is caused by losses in the cables. This slope may be understood by looking at the input impedance of a transmission line from the generator.

If the conductance G may be neglected

$$Z_{in} = \sqrt{\frac{L}{C} + \frac{R}{j\omega C}}$$

This may be reduced to

$$Z_{in} \approx \sqrt{\frac{L}{C}} \left(1 - j \frac{R}{2\omega L} \right) + \text{higher order terms}$$

(This last equation may be treated as a lumped impedance attached to the source as shown in figure 10(A).

Assuming Z_s is equal to R' , it can be seen that the voltage input of the transmission line will step to one-half the source voltage, and then rise exponentially as shown in figure 10(B). The initial slope m_i of the exponential is

$$m_i = \frac{\epsilon_s \max}{4 R' C} = \frac{\epsilon_s \max R}{8L} \text{ volts/sec}$$

Since the sampling oscilloscope always sees the sum of the incident voltage and the reflected voltage, the apparent upward slope of the reflected voltage is actually caused by the rising incident voltage at the input of the transmission system.

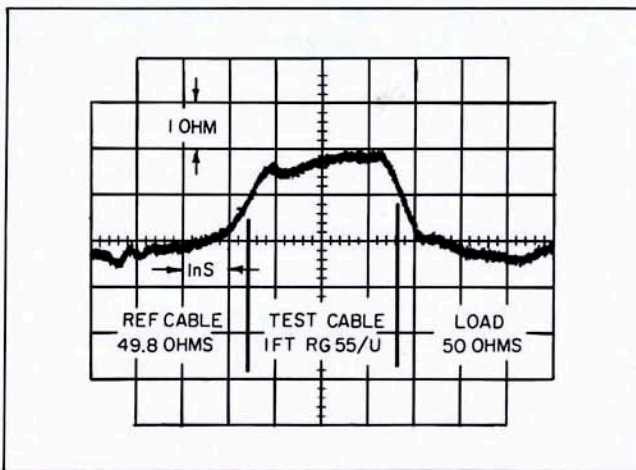

Figure 8(A). Reflection from 1 foot of RG 55/U cable. The reference cable Z_0 was 49.8 ohms, the load was 50 ohms, and the voltage source was the Model 213 Pulse Generator.

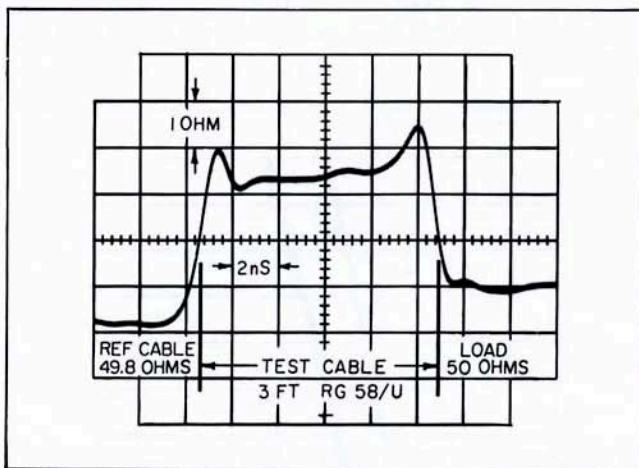

Figure 8(B). Reflection from 3 feet of RG 58/U cable. The reference cable Z_0 was 49.8 ohms, the load was 50 ohms, and the voltage source was the oscilloscope sync pulse output.

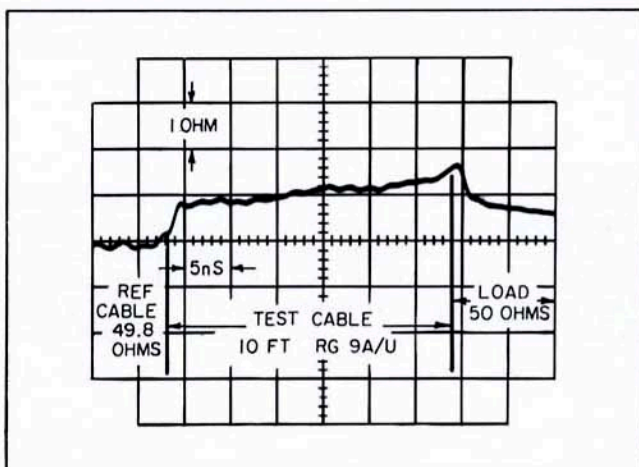

Figure 8(C). Reflection from 10 feet of RG9A/U cable. The reference cable Z_0 was 49.8 ohms, the load was 50 ohms, and the oscilloscope sync pulse output provided the voltage step.

The series resistance R is a function of the skin depth of the conductor and therefore is not constant with frequency. As a result, it is difficult to relate the slope of the exponential with an actual value of R . However, the magnitude of slope is useful in comparing cables of different loss.

This measuring technique is not limited to 50-ohm lines. The characteristic impedance of any line may be measured. Either the reference cable or the load may be used as a calibrating reference. The ability to differentiate between two closely spaced discontinuities is a function of the rise time of the oscilloscope and of the voltage step. Using an oscilloscope such as the hp Model 185B, which has a rise time of about 0.35 nanoseconds, and a voltage step of about 0.2 nanoseconds rise time as produced by the hp Model 213A Pulse Generator, the reflection from a reactive discontinuity has a pulse width at the 1/2 voltage points of about 1 nanosecond (see figure 4).

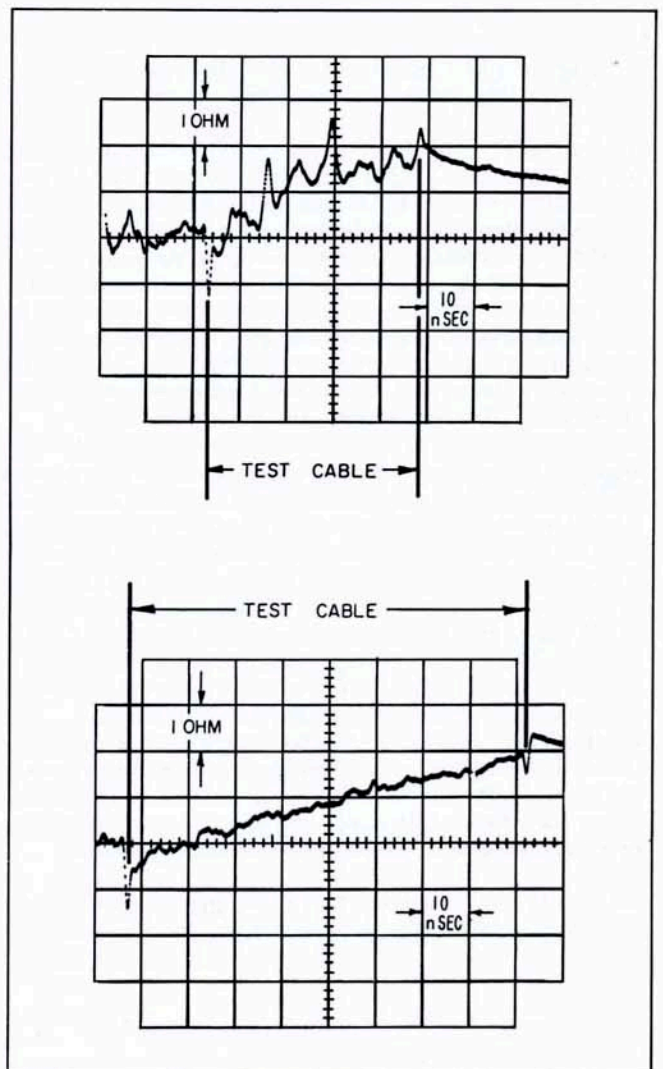

Figure 9. Reflections from two RG223/U cables made by different manufacturers. The reference cable Z_0 was 49.8 ohms, and the load was 50 ohms.

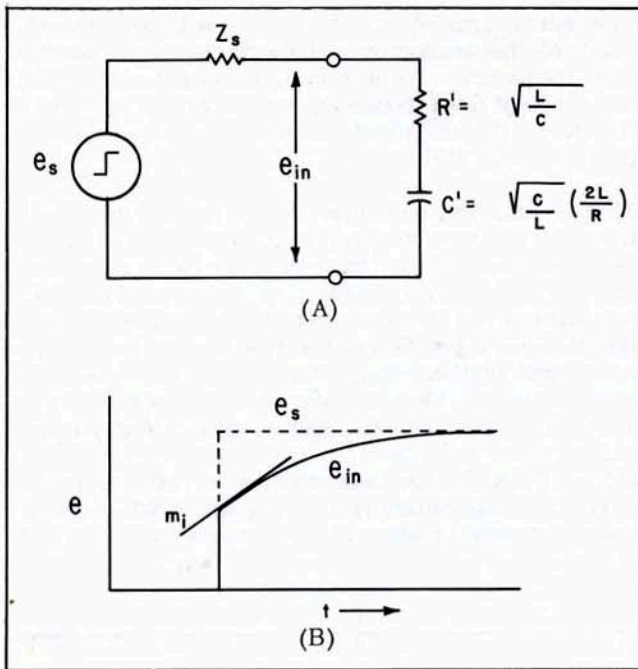

Figure 10. Circuit and graph illustrate how cable losses are related to slope.

Assuming a velocity of propagation in the line equal to the speed of light, the voltage step will travel 30 centimeters in 1 nanosecond. The time between the reflections caused by two discontinuities is equal to the time required for the step to propagate down the line and back again. Thus, two discontinuities spaced 15 centimeters apart will be separated by 1 nanosecond on the oscilloscope. At this spacing, the reflections are still well defined. In cables with a velocity factor of 0.66, the 1 nanosecond spacing represents 10 centimeters, or about 4 inches.

Wide Dynamic Range - Several unique characteristics of the sampling oscilloscope are utilized with these measurements. As mentioned before, rise time of the instrument determines the space resolution of the measurement. The dynamic range of the oscilloscope is also very important. The oscilloscope probe sees at all times the sum of the incident and reflected voltages. These two voltages may have a ratio as great as 1000 to 1. Thus, if the incident voltage step is 2 volts, the reflection might be 2 millivolts. The oscilloscope must be able to look at the 2-millivolt reflection without saturating because of the presence of the 2-volt incident step. In addition, the sweep speed of the oscilloscope must be great enough to properly resolve closely spaced discontinuities.

The truly synchronized dual trace presentation of the Model 185B Oscilloscope also makes possible the

direct comparison of two transmission systems. For example, the electrical lengths of two long cables may be matched to a few millimeters. This is done by setting up both probes as shown in figure 2 and driving them both from the same step output, with sufficient padding to keep the reflections from interacting. Figure 11 shows two cables whose delay differs by 0.1 nanoseconds. This is equivalent to about one centimeter difference in electrical length.

The usefulness of the sampling oscilloscope technique in pulse-reflection testing is not limited to transmission lines. This technique has been used at Hewlett-Packard to measure the resistive impedance of a crystal mixer which is being driven with a local oscillator voltage. The technique is also used on the production line to help reduce reflections in a step attenuator which consists of microswitches, connecting wires and resistors as part of a 50-ohm system.

As sampling oscilloscopes and pulse generators are developed with faster rise times, the applications and usefulness of this technique will also expand.

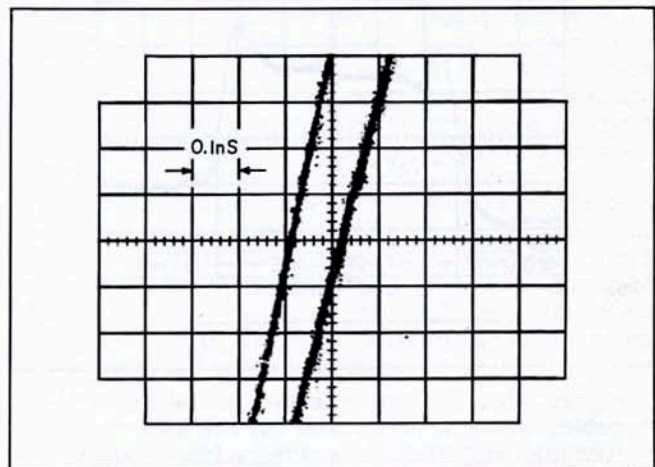

Figure 11. Reflections obtained using the synchronized dual trace capability of the 185B to compare cable lengths. In this case there is an electrical difference of 1 cm.

Acknowledgement: Portions of this Application Note first appeared under the title "Testing Microwave Transmission Lines Using the Sampling Oscilloscope", by Harley Halverson, in the June 30, 1961 issue of Electronic Design. The author was assisted by Luiz Peregrino in developing the pulse-reflection technique.