

APPLICATION NOTE 52-2

TIMEKEEPING
AND
FREQUENCY
CALIBRATION

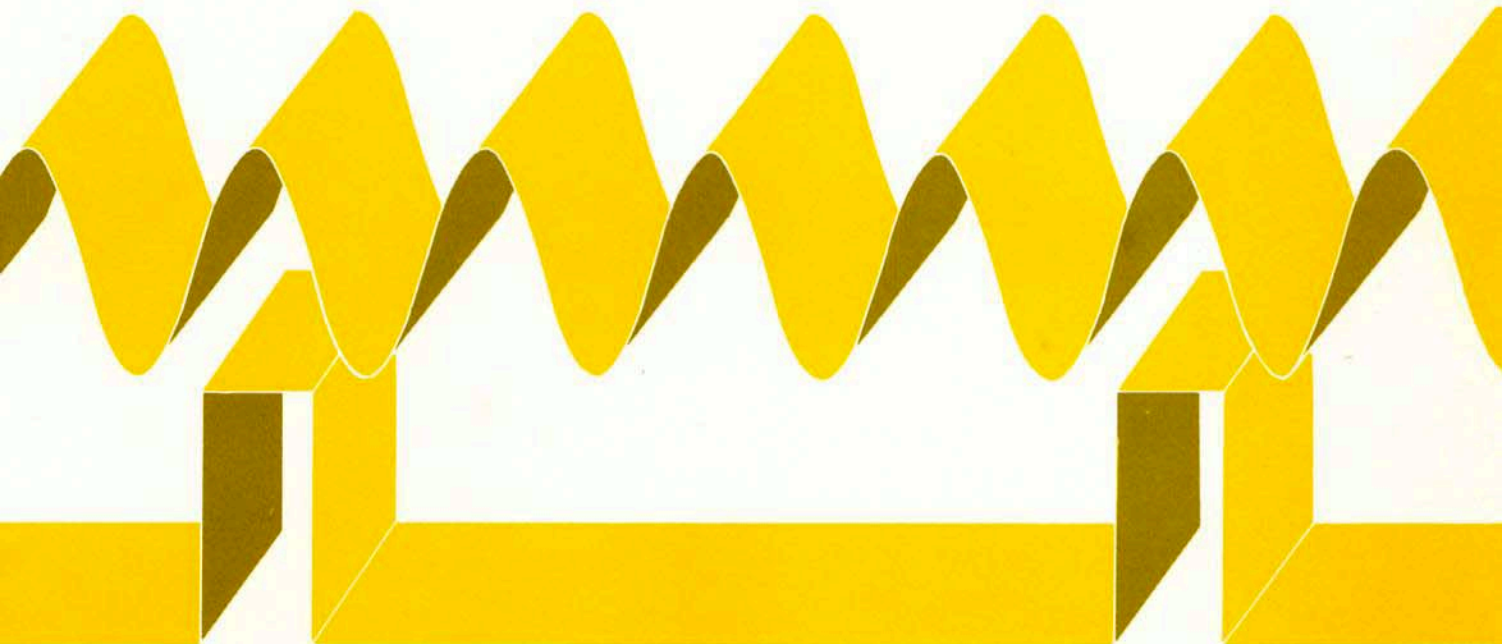

Application Note 52-2

**TIMEKEEPING
AND
FREQUENCY CALIBRATION**

TABLE OF CONTENTS

	Page
I. Introduction	1-1
General	1-1
Timekeeping	1-2
Timekeeping System Design Considerations	1-2
II. Considerations in Timekeeping Systems	2-1
Accurate Frequency and Time Transfer	2-1
Radio Propagation Path Delays	2-1
Frequency Calibration Interval	2-2
Long Term Effects of Noise	2-7
Effects of Environmental Conditions	2-11
III. Methods for Precise Frequency Standard Intercomparison	3-1
General	3-1
Oscilloscope Lissajous Patterns	3-1
Oscilloscope Pattern Drift	3-2
Direct Frequency Comparison with a Counter	3-3
Direct Counter Readout of Normalized or Fractional Frequency Error	3-5
Frequency Comparison with a Vector Voltmeter	3-8
Frequency Comparison with a Phase Comparator and Strip Chart Recorder	3-9
Frequency Determination from Time Comparisons	3-10
IV. Time and Frequency Transfer	4-1
Comparison of Various Time and Frequency Transfer Techniques	4-1
High Frequency Transmissions	4-3
Low Frequency (LF) and Very Low Frequency (VLF) Transmissions	4-5
Loran C Navigation System	4-10
Television Signals	4-14
Portable Clocks	4-18
Other Time and Frequency Transfer Methods	4-22
A. Radio Propagation Path Delays	A-1
Computation of the Great Circle Distance	A-1
Transmission Modes	A-1
HF Signal Multiple Hops	A-2
Height of Ionosphere	A-4
Delay Determination	A-4
B. Derivation of Time Error Equation	B-1
C. Recalibration Charts for Quartz Oscillators and Rubidium Standards	C-1
D. Variance of Time Interval for Calibrated Clocks	D-1
E. Daily Phase Values and Time Differences Series 4	E-1
F. Derivation of Fractional Frequency Deviation Equation	F-1
G. Bibliography	G-1
Acknowledgements	G-2

SECTION I

INTRODUCTION

GENERAL

TIME—a very complex subject. Man has been interested since his beginning in the measurement and use of time. Early time measurement systems involved counting the number of days in terms of sunrises, sunsets, or moons. Later, the day was divided into smaller increments by using the sundial, hourglass, candles, lengths of rope, etc. With the discovery of the pendulum, even smaller increments were used and clocks were born. The accuracy of early clocks was around 1 part in 10^3 to 1 part in 10^4 .

As more accurate clocks were produced, new uses of time measurement were explored. As new uses were discovered, the need for even more accurate clocks became apparent.

Currently the state-of-the-art in atomic frequency standards has attained an accuracy of 2 parts in 10^{13} in the laboratory. Today the specified accuracy in commercially available atomic clocks has reached ± 7 parts in 10^{12} . This unprecedented commercial accuracy is equivalent to a gain or loss of 1 second in a minimum of 4530 years. Currently, timekeeping consists of maintaining clocks within fractions of microseconds of each other, whereas forty years ago, people were concerned about milliseconds at best. This need to maintain clock systems within fractions of a microsecond is shared by numerous applications spanning international boundaries. Worldwide applications cause strong international pressures to be exerted upon all clock systems to create even more accurate clock synchronization schemes on a global basis. As a result, several techniques of transferring time have been developed which allow accuracies of transfer from milliseconds to 100 nanoseconds.

Before starting the discussion of timekeeping, a review of a few of the basic concepts of time and frequency is in order. First of all, a clock can be defined as a device which counts the number of events that occur from an arbitrary starting point. The events to be counted could be the swings of a pendulum, the oscillations of a quartz crystal, the cycles of a signal in resonance with cesium or some other sequence of events. Accepted units of time are discussed in Application Note 52-1, Fundamentals of Time and Frequency Standards. For the purposes here, the terms of the internationally accepted time scale, Coordinated Universal Time (UTC) whose basic unit is the second will be used. The second was defined by the XIII General Conference of Weights and Measures, in October 1967, as “the duration of 9,192,631,770 periods of the radiation corresponding to the transition between the two hyperfine levels of the ground state of the cesium atom 133”. Therefore, the definition of a clock can be expressed as a device which counts the number of seconds (a well defined measurement of time-interval), occurring from an arbitrary starting time. From this definition it appears that a clock needs three basic parts. First, a source of events to be counted. This source can be labeled a frequency standard, frequency source, or time interval standard. Second, a means of accumulating these events or oscillations, and third a means of displaying the accumulation of time. Figure 1-1 shows a simple clock block diagram, including

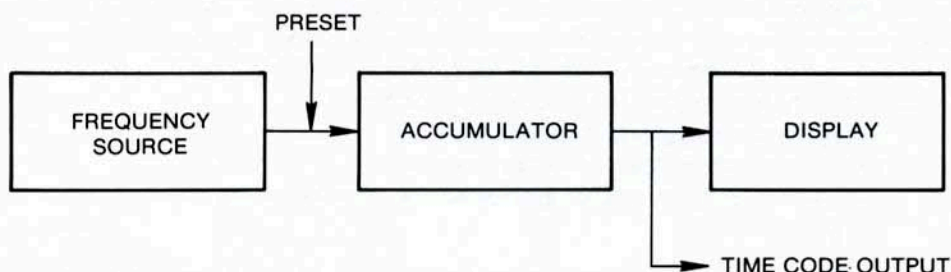

Figure 1-1 Basic Clock

a method of presetting the arbitrary starting time and obtaining an electrical time reading from the clock (time-code-generator).

In a clock there are two major sources of error, the accuracy and stability of the frequency source, and the accuracy of the establishment of initial setting (called epoch). Application Note 52-3 discusses the stability of frequency sources, while this application note discusses the methods of accomplishing accurate time transfer and maintaining frequency accuracy (often called calibration, frequency matching or frequency keeping).

TIMEKEEPING

Timekeeping is the process of maintaining accurate frequency and obtaining accurate time transfer. The timekeeping process involves intercomparing two or more clocks to insure that their time difference is kept within certain limits over a specified time interval. This action requires that the two clocks accumulate time at the same rate (same frequency within limits) but equally important, they must be set to the same starting time (reference time) as accurately as the system requires.

A timekeeping system can be either a relative or an absolute synchronization system. In a relative timekeeping or synchronization system the concern is placed upon keeping the clocks in the system synchronized with each other but not necessarily synchronized with other clocks outside the system. An example of a relative system would be a communications network where all clocks are referenced to the master clock of the system and the major concern is keeping the frequency of the network within appropriate limits for good network operation (e.g., a TV network). An absolute timekeeping system, on the other hand, is concerned not only with maintaining time synchronization of clocks within the system, but also with clocks outside the system. Even more specifically, an absolute timekeeping system is concerned with maintaining time synchronization with the internationally accepted time scale, Coordinated Universal Time (UTC).*

Before turning to the mechanics of frequency calibration and time transfer, some of the design considerations of a timekeeping system will be discussed.

TIMEKEEPING SYSTEM DESIGN CONSIDERATIONS

The purpose of this application note is to assist in the design or establishment of a timekeeping or frequency keeping system. These time or frequency keeping systems may in fact be a subsystem of a communications system, navigation system, or other system requiring time or frequency for its operation.

Prior to selecting specific components, instruments, processes and procedures in a timekeeping system, the system designer must answer several basic questions.

1. Is frequency or time (which implies frequency as well) needed for effective system operation? If frequency only is needed, the system can be much simpler than if time has to be provided as well.
2. Is absolute timekeeping necessary or will relative timekeeping suffice? A relative system may not need the equipment to synchronize with an external reference. This decision may depend on certain regulations (e.g., from the Federal Telecommunications Standards Committee, Fed-Std-1002, April 22, 1974, available from U.S. GSA).
3. What accuracy is required for frequency? for time?
 - a. What regulations pertain to this system?
 - b. What does system performance require?
 - c. Will either regulations or performance requirements change in the future? If so, when?

* For an explanation of UTC and other time scales, refer to AN 52-1, Fundamentals of Time and Frequency Standards, Hewlett-Packard, March 1974.

Each system should be designed to provide at least the minimum accuracy defined by either regulation or performance. Future needs should be anticipated to insure against premature obsolescence of equipment due to increased requirements.

4. What stability is required? Some systems are concerned not only with accuracy but with stability of the frequency source or time jitter of the time-code as well. Application Note 52-3, Stability: Theory and Measurement, is more detailed in this area.
5. What equipment and systems are available for frequency comparison and time transfer? Equipment is generally available on a worldwide basis, but time transfer systems are not. The user's system has to take into account the time transfer or frequency comparison facilities available to him in the location or locations where his system is to be installed.
6. What additional equipment will have to be purchased or designed and built? The user needs to determine what equipment he has available that satisfy his needs and what equipment has to be purchased. Generally speaking most equipment is available as off-the-shelf units, however, occasionally the user may have to design and build some equipment not available in the marketplace. This will normally stretch his time to get the system operating.
7. What funds are available for establishing the system? Generally off-the-shelf equipment will lower the cost of the system. Equipment designed by the user will normally increase the cost of the system. If funds are critical, then a redesign of the system to make more use of readily available commercial hardware may be appropriate.
8. What funds are available for the operation of the system? The operating costs of the system can be very large compared to the initial cost. If funds are limited for operation, then perhaps an increase in funding for initial purchase will allow more accurate and reliable equipment to be purchased, thereby reducing operating costs.
9. What trade-offs can be made? Normally, many trade-offs have to be considered in any design. Trade-offs are generally made in terms of costs: performance vs. costs, operating costs vs. procurement costs, off-the-shelf cost vs. user build cost, etc.

There are numerous sources of assistance available to the system designer in satisfying his requirements. The Hewlett-Packard Company provides application notes discussing various instruments and their applications as well as providing technical assistance through the field sales offices.

The remainder of this application note is divided into three sections. Section II approaches time-keeping from the viewpoint of technical considerations for a timekeeping system. Section III discusses several methods of comparing the frequency of two or more sources. Section IV is concerned with various methods of timekeeping including frequency comparison or matching and time-transfer.

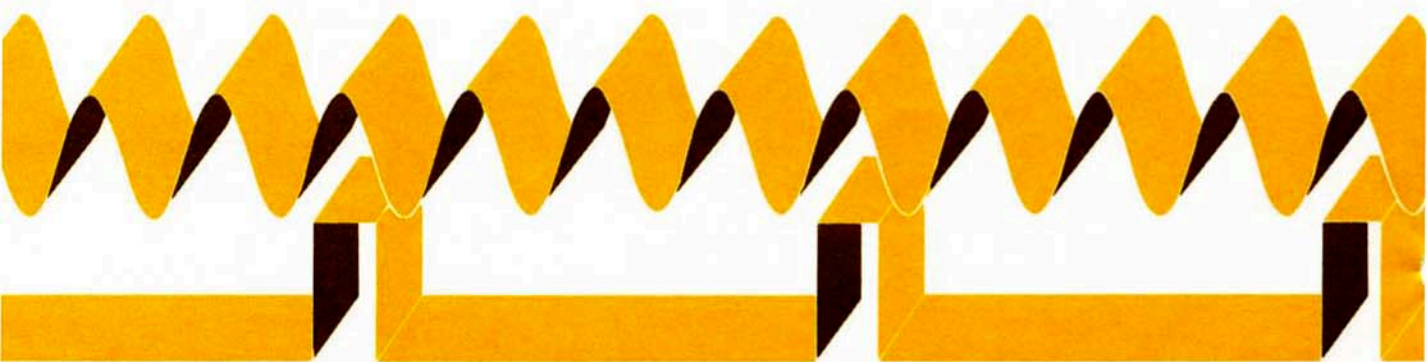

SECTION II

CONSIDERATIONS IN TIMEKEEPING SYSTEMS

In establishing a timekeeping system, the system designer or operator has to deal with several different sources of error. There are six major problem areas which contribute to errors in timekeeping:

1. Maintenance of accurate frequency;
2. Obtaining accurate time transfer;
3. Determination of radio propagation path delays;
4. Maximization of the frequency calibration interval;
5. Determination of the effects of noise in frequency generating equipment;
6. Determination of the effects of changing environmental conditions.

In this section, we shall discuss these problem areas in terms of their effects and methods of reducing their impact.

As mentioned earlier, it is impossible to be exact when dealing with frequency and time. However, it is possible to be 1000 times more accurate in frequency measurements than in the measurement of any other physical quantity. Therefore, prior to analyzing the effects and impact of these sources of error, it is necessary to determine the level of accuracy required and the tolerances essential for the individual application. Once the essential tolerances have been established, the sources of error can be analyzed to determine if they impact on the system operation. If they do in fact affect the system operation, then appropriate steps can be taken to reduce the impact.

ACCURATE FREQUENCY AND TIME TRANSFER

Basic to any timekeeping system is the establishment and maintenance of accurate frequency and obtaining an accurate time transfer. Inherent in the word accurate when dealing with physical measurements is the phrase: within given tolerances. Two essential ingredients are (1) stable frequency sources or clocks; and (2) a method of frequency comparison and time transfer which provides the required accuracy within given tolerances.

Section III deals with several frequency comparison techniques which can provide various levels of accuracy. Section IV identifies and compares time transfer techniques providing not only several levels of accuracy for time transfer but for frequency comparison as well.

RADIO PROPAGATION PATH DELAYS

In order to accomplish time transfer via radio waves, the radio propagation path delay has to be determined as accurately as possible. However, most techniques for initial time transfer will allow accuracies to only a millisecond or so. Normally for highly stable propagation paths (e.g. OMEGA or LORAN-C) we desire very precise time transfer within a microsecond. This level of accuracy is only possible for initial time transfer using the portable clock technique discussed in Section IV. Subsequent time transfers using highly stable propagation means can provide sub-microsecond accuracies.

For those systems which do not require microsecond accuracy, Appendix A contains techniques for determining the radio propagation path delays from computation of the Great Circle Distance.

FREQUENCY CALIBRATION INTERVAL

A time system, based upon a quartz oscillator or a rubidium standard of known drift rate, can be kept within prescribed limits of error with infrequent adjustments through a systematic approach.

In this approach, the oscillator and clock are preset to offsets that will keep the time system operating within a selected accuracy for a long time despite the oscillator's drift. This drift (aging rate) must be known and must be nearly constant, so that a plot of the frequency over the adjustment interval can be approximated by a straight line. In the following, it will be assumed that the oscillator's aging rate has been established by comparisons of the oscillator against a standard.

The basic equations are presented first, then the method is illustrated with a problem solved by calculation.

Time Error vs. Frequency. The frequency at any time t can be expressed (with the frequency changes versus time approximated by a straight line):

$$f_t = f_o + af_r t \tag{Eq. 1}$$

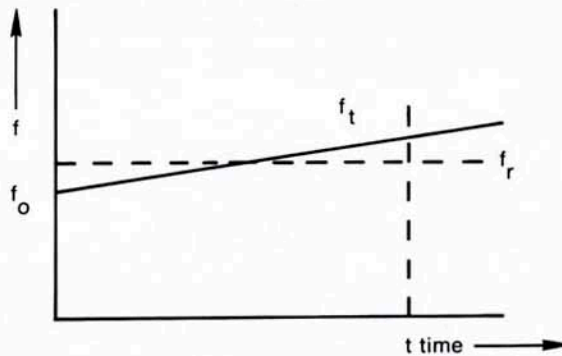

Figure 2-1. Oscillator Frequency Vs. Time

Where:

- f_t = frequency at time t
- f_o = initial frequency at time $t=0$
- f_r = reference frequency (desired, zero error)
- a = aging rate (fractional parts per unit time)

From the derivation contained in Appendix B the total time error is:

$$E = E_o + \left(\frac{f_o}{f_r} - 1\right) t + \frac{at^2}{2} \tag{Eq. 2}$$

Equation 2 indicates that the total time error at any time t depends upon the values of four quantities: (1) initial time error E_0 ; (2) initial frequency f_0 ; (3) aging or drift rate a ; and (4) elapsed time t .

A plot of Equation 2 as a function of time is a parabola for which vertical displacement depends upon the value of E_0 , Figure 2-2. The corresponding frequency plot is shown beneath the error plot.

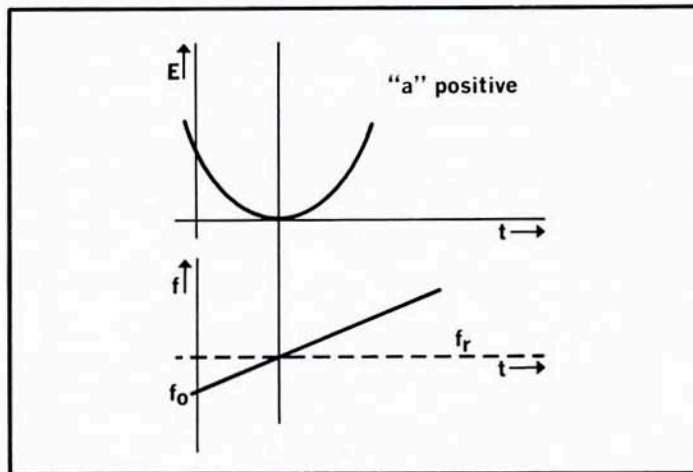

Figure 2-2. Positive Frequency Drift

Note that the oscillator frequency is precisely equal to the reference frequency at the point corresponding to the vertex of the error parabola. This is as it should be, for the slope of the curve must be zero where the two frequencies agree.

If the frequency drift were negative, the parabola would be inverted (Figure 2-3).

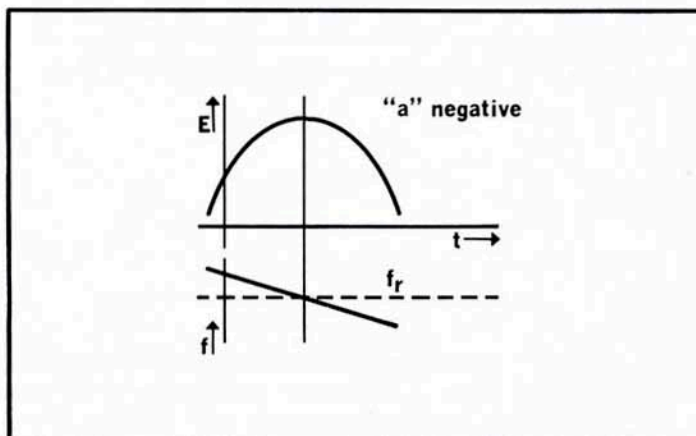

Figure 2-3. Negative Frequency Drift

Figure 2-4 shows corresponding plots of frequency and time error to clarify their relationship.

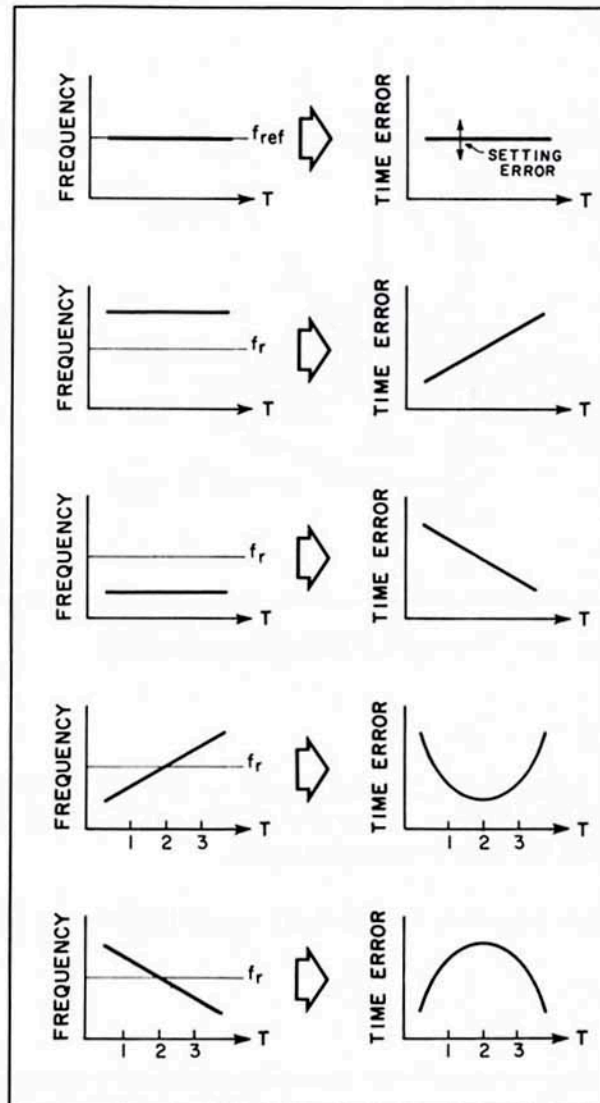

Figure 2-4. Corresponding Frequency and Time Plots

Example:

As a specific problem, consider a time system to be maintained within $\pm 10 \mu\text{s}$. The signal that drives the clock is derived from a rubidium standard with a known drift rate, a , of $+ 1 \times 10^{-11}/\text{month}$. The quantities to be determined are: (a) The initial time error E_0 , set on the clock. (b) The initial frequency offset f_0 . (c) The length of the recalibration cycle T_2 , i.e., the number of days the clock is left untouched between resettings.

The elapsed time during which the error of the clock is less than 10 microseconds can be maximized by selection of initial conditions such that the error plot and the frequency plot are situated as shown in Figure 2-5.

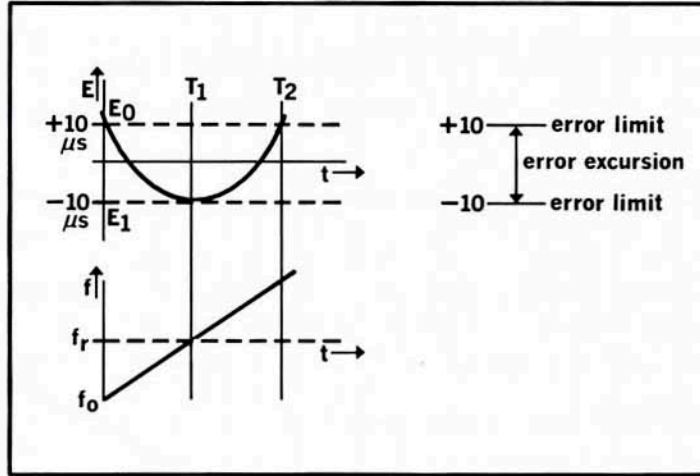

Figure 2-5. Frequency and Time Error

In the sketch, $t=T_1$ when the time error plot has a slope of zero. The parabola was positioned vertically such that its vertex at T_1 does not exceed the selected error limit, $-10\mu s$. This is accomplished by setting E_0 , the initial error, at the other error limit, $+10\mu s$. We now have answer (a): $E_0 = +10\mu s$.

Also, the oscillator frequency is initially set to a certain offset. These two steps maximize the elapsed time T_2 during which the system lies within the selected limits of error.

The general equation (Eq. 2) is now solved for f_0 and T_2 .

$$E = E_0 + \left(\frac{f_0}{f_r} - 1\right) t + \frac{at^2}{2}$$

At time $t=T_1$, $E=E_1$

$$E_1 = E_0 + \left(\frac{f_0}{f_r} - 1\right) T_1 + \frac{aT_1^2}{2}$$

But $E_1 = -E_0$, therefore:

$$-E_0 = E_0 + \left(\frac{f_0}{f_r} - 1\right) T_1 + \frac{aT_1^2}{2}$$

$$0 = 2E_0 + \left(\frac{f_0}{f_r} - 1\right) T_1 + \frac{aT_1^2}{2} \quad (\text{Eq. 3})$$

There are two unknowns, T_1 and f_0 . Since the slope is known to be zero at $t = T_1$:

$$\frac{dE}{dt} = 0 \text{ at } t = T_1$$

From Equation 1,

$$E = E_0 + \left(\frac{f_0}{f_r} - 1\right) t + \frac{at^2}{2}$$

$$\frac{dE}{dt} = 0 = \frac{f_0}{f_r} - 1 + \frac{a}{2}(2T_1) = \frac{f_0}{f_r} - 1 + aT_1$$

$$aT_1 = 1 - \frac{f_0}{f_r}$$

$$\frac{f_0}{f_r} = 1 - aT_1 \quad (\text{Eq. 4})$$

Substituting into Equation 3:

$$0 = 2E_0 + (1 - aT_1 - 1) T_1 + \frac{aT_1^2}{2}$$

$$= 2E_0 - \frac{aT_1^2}{2}$$

$$-4E_0 = aT_1^2$$

$$T_1^2 = \frac{4E_0}{a}$$

$$T_1 = 2 \sqrt{\frac{E_0}{a}} \quad (\text{Eq. 5})$$

The parabola is symmetric about T_1 :

$$T_2 = 2T_1$$

Hence, T_2 in terms of the initial error E_0 and the drift rate a , is:

$$T_2 = 4 \sqrt{\frac{E_0}{a}} \quad (\text{Eq. 6})$$

To solve the problem numerically we substitute:

$$E_0 = 10 \times 10^{-6} \text{ sec} \times \frac{1 \text{ day}}{8.64 \times 10^4 \text{ sec}} = 1.16 \times 10^{-10} \text{ day}$$

$$a = \frac{1 \times 10^{-11}}{\text{month}} \times \frac{\text{month}}{30 \text{ days}} = 3.33 \times 10^{-13} / \text{day}$$

$$T_2 = 4 \sqrt{\frac{1.16 \times 10^{-10} \text{ day}}{3.33 \times 10^{-13} / \text{day}}} = 4 \sqrt{3.48 \times 10^2} = 75 \text{ days Answer (c)}$$

The oscillator can operate for 75 days without recalibration. The oscillator's initial offset must be calculated from Equation 4:

$$\frac{f_o}{f_r} = 1 - aT_1$$

$$f_o = f_r (1 - aT_1)$$

But

$$T_1 = \frac{T_2}{2} = 37.5 \text{ days}$$

$$a = 1 \times 10^{-11}/\text{mo} \times 1/30 \text{ mo/day} = 3.33 \times 10^{-13}/\text{day}$$

$$f_o = f_r (1 - (3.33 \times 10^{-13}) (37.5)) = f_r (1 - 1.25 \times 10^{-11}) \text{ Answer (b)}$$

It is clear that the oscillator must be set to a frequency lower than reference frequency by 1.25 parts in 10^{11} .

Appendix C contains recalibration charts for both quartz oscillators and rubidium standards which provide a handy reference for quick approximations of the number of days required between resettings for various levels of accuracy desired.

Regardless of whether the equation or the chart is used to determine recalibration time, it should be recognized that they are based upon perfect conditions and considerable operator skills. In reality, the environment plays a very important part in calculations of time excursions. Temperature changes, vibrations, shock, etc. can increase or decrease the frequency depending upon the individual oscillators characteristics. Also, the noise processes in the instrument, especially for the most precise tolerances, add or detract from our confidence in the answer derived. These areas are discussed later in this section.

LONG TERM EFFECTS OF NOISE

Every frequency source has a certain amount of noise inherent in the circuitry and components. The noise generated causes effects in the short-term stability and the long-term stability. The effects of noise on the short-term stability will be covered in AN 52-3, Stability: Theory and Measurement. The long term effects of noise are important in timekeeping applications.

We assume a frequency calibration (measurement) time interval, T_c , during which the system clock is compared against a reference to determine its average frequency. Following a dead time, T_d , the phase or time of the clock is measured and we wish to estimate the variance in the indicated time after an interval, T_p , where we assume the correction determined during the calibration is applied.

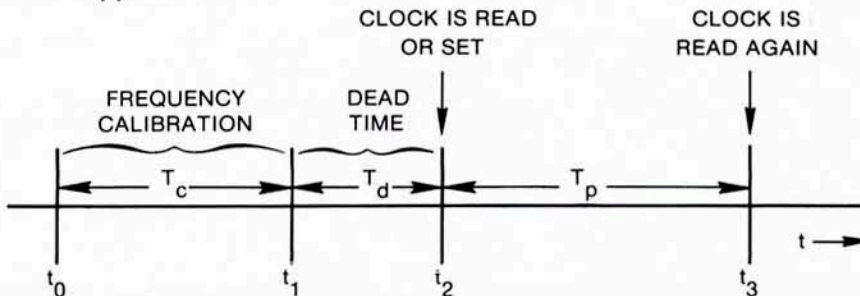

Figure 2-6. Variance in Time Interval

Appendix D, Variance of Time Interval for Calibrated Clocks derives a set of equations which can be used to estimate the variance. There are two types of noise in the instrument which affect the accumulation of time and produce uncertainties in the predictability of a given set of clocks. The two types of noise are white FM and flicker FM.

For an example, let us examine two HP 5061A, Option 004 High Performance Cesium Standards which are intercompared for 10 days and then the clocks are intercompared again after 60 days. What is the one-sigma certainty that we predict the time difference in sixty days?

White FM component: from equation 5 in Appendix D.

$$\overline{E}_W^2 = \frac{A}{2} \left(T_p + \frac{T_p^2}{T_c} \right)$$

where

$$\begin{aligned} T_c &= 10 \text{ days} = 8.64 \times 10^5 \text{ sec} \\ T_p &= 60 \text{ days} = 5.184 \times 10^6 \text{ sec} \end{aligned}$$

and for Option 004:

$$A = 1.28 \times 10^{-22} \text{ sec}$$

$$\overline{E}_W^2 = \frac{1}{2} (1.28 \times 10^{-22}) \left[5.184 \times 10^6 + \frac{(5.184 \times 10^6)^2}{8.64 \times 10^5} \right]$$

$$\overline{E}_W^2 = 2.32 \times 10^{-15} \text{ sec}^2$$

Flicker FM component: from equation 6, Appendix D.

$$\begin{aligned} \overline{E}_f^2 = B T_p^2 \left\{ \frac{(T_p + T_d + T_c)^2}{T_p T_c} \ln \left(1 + \frac{T_p + T_d}{T_c} \right) \right. \\ \left. + \frac{T_d^2}{T_c T_p} \ln \frac{T_d}{T_c} - \ln \frac{T_p}{T_c} \right. \\ \left. - \frac{(T_p + T_d)^2}{T_p T_c} \ln \frac{(T_p + T_d)}{T_c} \right. \\ \left. - \frac{(T_c + T_d)^2}{T_p T_c} \ln \left(1 + \frac{T_d}{T_c} \right) \right\} \end{aligned}$$

where $T_d = 0$

and for Option 004: $B = 6.5 \times 10^{-28}$

$$\begin{aligned} \overline{E_f^2} = & (6.5 \times 10^{-28}) (5.184 \times 10^6 \text{ sec})^2 \left\{ \frac{(60 + 0 + 10)^2}{(60)(10)} \ln \left(1 + \frac{60 + 0}{10} \right) \right. \\ & + \frac{0}{(60)(10)} \ln \frac{0}{10} - \ln \frac{60}{10} \\ & \left. - \frac{(60 + 0)^2}{(60)(10)} \ln \frac{(60 + 0)}{10} - \frac{(60 + 0)^2}{(60)(10)} \ln \left(1 + \frac{0}{10} \right) \right\} \end{aligned}$$

NOTE: We can use days instead of seconds inside the brackets because the seconds conversion will cancel.

$$\begin{aligned} E_f^2 &= (1.7468 \times 10^{-14} \text{ sec}^2) \left\{ \frac{70^2}{600} \ln 7 + 0 - \ln 6 - \frac{60^2}{600} \ln 6 - 0 \right\} \\ &= 5.85 \times 10^{-14} \text{ sec}^2 \end{aligned}$$

The total variance is computed from the two components by:

$$\begin{aligned} \overline{E_T^2} &= \overline{E_W^2} + \overline{E_f^2} \\ &= 2.32 \times 10^{-15} \text{ sec}^2 + 5.85 \times 10^{-14} \text{ sec}^2 \\ &= 6.08 \times 10^{-14} \text{ sec}^2 \\ E_T &= 2.466 \times 10^{-7} \text{ sec} \\ E_T &= 246.6 \text{ nsec} \end{aligned}$$

Therefore, the one-sigma certainty of predicting the time difference 60 days from the start point is ± 246.6 nsec.

For the second example let us examine a timekeeping system where the user wants to determine the maximum that four high performance cesium standards (HP 5061A, Option 004) can remain within $1 \mu\text{sec}$ of each other.

To simplify the problem, we designate one of the clocks as the master and compare the other three to it. Secondly, we assume that one of the three clocks will be worse than the others and therefore we can reduce the basic problem to one involving two clocks. Using the 10638A De-gausser with the High Performance Cesium Standards allows a settability of 1×10^{-13} . Once the clocks are set, at the end of the comparison time, T_C , we would expect zero frequency shift for CONSTANT environment. However, we know noise affects the overall time accumulation. Figure 2-7 shows the problem in a graphical form. We find the error components for settability and noise and add to find the total error.

First, let us examine the settability error. In an ideal case, the variance, E_T is zero. Therefore the maximum time to remain within $1\mu\text{sec}$ is simply related to the settability (with CONSTANT environment) from (derived in Appendix F)

$$\left| \frac{\Delta t}{T} \right| = \left| \frac{\Delta f}{f} \right|$$

we find

$$T_{\text{ideal}} = \frac{\Delta t}{\frac{\Delta f}{f}} = \frac{1\mu\text{sec}}{1 \times 10^{-13}} = 10^7 \text{ sec} = 115.7 \text{ days}$$

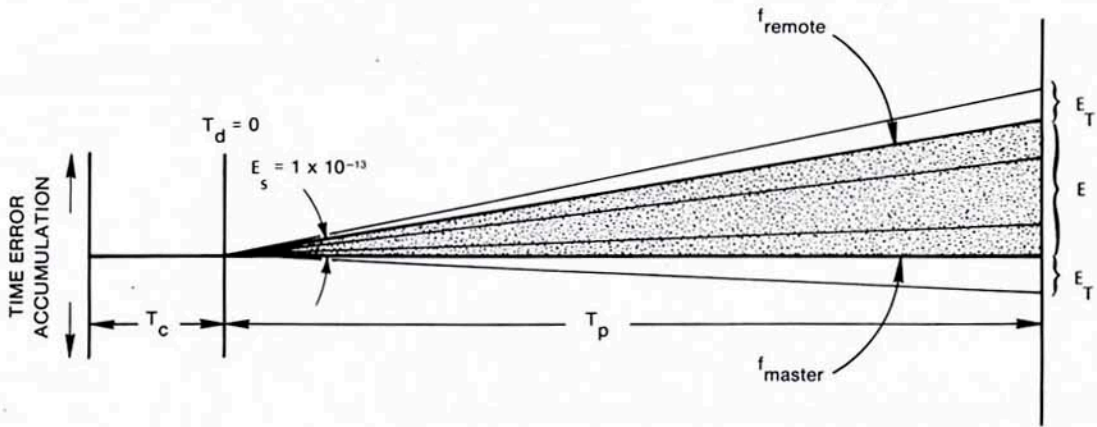

Figure 2-7. Comparison of Two Clocks

Second, we need to determine the noise component of the error. To compute the one sigma probability of remaining within $1\mu\text{sec}$ (again assuming CONSTANT environment) we have to satisfy the following equation.

$$E + 2E_T = 1\mu\text{sec} \quad (\text{Eq. 7})$$

where

$$E = E_s T_p$$

$$E_s = \frac{\Delta f}{f}$$

and

$$E_T = \sqrt{E_w^2 + E_f^2}$$

The factor of 2 in Equation 7 assumes the unlikely worst case, that the two clocks' random errors are identical and opposite, i.e. the noise processes have a correlation coefficient of -1 . If the two clocks are uncorrelated (likely) the factor $\sqrt{2}$ should be used.

A programmable calculator will greatly assist in the determination of T_p (max) through repeated iterations. If we assume a T_c of 10 days and $T_d = 0$, the iterations yield $T_p = 60$ days. With $T_p = 60$ days; $E_T = 246.6 \text{ nsec}$ as shown in the previous example.

$$\begin{aligned} E_f &= E_s T_p + 2E_T \\ &= 518.4 \text{ nsec} + 2(246.6) \text{ nsec} \\ &= 1.011 \mu\text{sec} \end{aligned}$$

which is barely over the $1\mu\text{sec}$ allowable.

EFFECTS OF ENVIRONMENTAL CONDITIONS

Environmental conditions are usually a major cause of error in precision timekeeping. For ultra-precise timekeeping, a controlled environment is the best. For real-time, transportable systems, the environment can be modeled and compared against environmental specifications to determine short and long-term effects on timekeeping. The prediction of timekeeping ability (in terms of tolerances allowable) is then directly related to the accuracy of the environmental model and the actual performance of the individual frequency sources.

The most conservative system design approach is to assume the worst case specified environmental sensitivities for the instrument and compare to the system specifications. An alternate scheme requires constant monitoring of the timekeeping systems performance to insure that environmental changes will be compensated or corrected.

For ultimate results in timekeeping, a computer modeling may be required to accurately predict the suitability of a given frequency source to a given set of environmental conditions. The environmental variables needed in the modeling include:

1. Effects of temperature and temperature changes on the frequency;
2. Effects of altitude and altitude changes on the frequency;
3. Effects of magnetic fields (AC and DC) on the frequency;
4. Effects of humidity on the frequency;
5. Effects of shock and vibration on the frequency;
6. Effects of gravity and orientation on the frequency;
7. Interdependency of effects.

Not only do these conditions affect the frequency of an oscillator, they can also affect the phase (e.g., the phase shift in an amplifier might change with temperature). This complicates the measurement of model parameters and affects the resultant model.

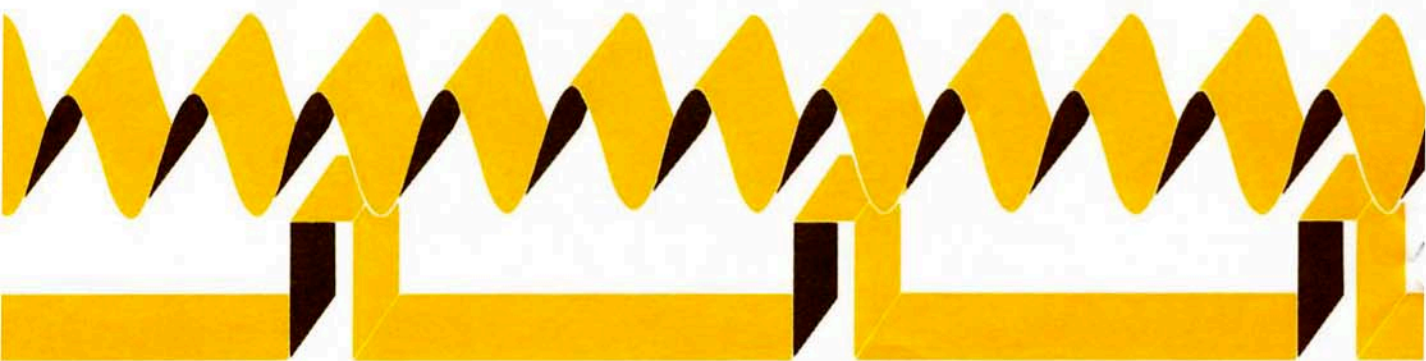

SECTION III

METHODS FOR PRECISE FREQUENCY STANDARD INTERCOMPARISON

GENERAL

This section presents methods by which frequency differences between two frequency sources can be determined. We assume for these methods that the two frequency sources are physically near each other. External references such as VLF, LF, LORAN C etc. will be discussed in the following section. This section establishes concepts and measurements fundamental to the time-transfer techniques of the next section.

To be useful, methods for comparing frequency sources, especially precision frequency sources, must be capable of resolving extremely small differences. This section describes eight such useful methods that have varying degrees of complexity and resolution. Two methods are described which involve the use of an oscilloscope for interpretation, while two others use the period measuring capability of an electronic counter for comparison purposes. Three other methods are presented which involve the direct measurement of phase characteristics versus-time. The last technique derives the frequency from measurements of time. Among these methods, at least one or two should be suitable for any type of short or long-term frequency standard comparison desired.

OSCILLOSCOPE LISSAJOUS PATTERNS

A well known method of comparing two frequencies is to observe the pattern displayed on an oscilloscope when one frequency is applied to its horizontal input and the other to its vertical input. If the ratio of the frequencies is an integer or the ratio of two integers, the resulting pattern, called a Lissajous figure (Figure 3-1) can be interpreted to determine this frequency ratio. If a rectangle is imagined to bound the pattern, the number of points where the loops are tangent on one vertical and one adjacent horizontal side directly indicates the ratio of the two frequencies.

When the two frequencies being compared in the Lissajous display are quite similar (within a few hertz) the trace will be elliptical. Slight frequency differences cause the ellipse to roll repeatedly through all orientations from 0° to 360° . It is possible to time the completion of a 360° sequence

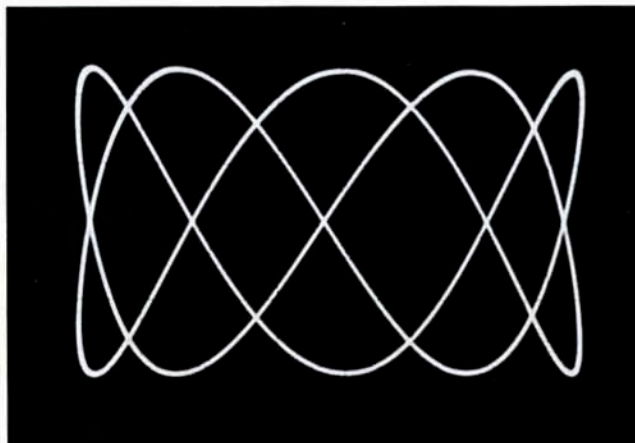

Figure 3-1. Lissajous Pattern

and to find the frequency difference, which is the reciprocal of this time (in seconds). To match the frequency of an oscillator closely to that of a house frequency standard, the oscillator is adjusted until the ellipse is stationary.

The practical limit for use of this technique for frequency offset adjustments and comparisons is about 1 part in 10^9 . It is of limited practicality for quantitative fractional frequency deviation measurements. Reference to a comprehensive presentation of Lissajous patterns is advisable before attempting to use them for comparison purposes.*

OSCILLOSCOPE PATTERN DRIFT

An oscillator can be compared against a house frequency standard by externally triggering the oscilloscope from the standard while a pattern of several cycles of the oscillator is displayed. The ratio of drift of the oscilloscope pattern is related to the frequency error of the oscillator under test. For example, suppose an HP Model 181A Oscilloscope is being used to check the time base oscillator frequency of an HP Model 5345A Electronic Counter against a house standard such as the HP Model 5065A Rubidium Vapor Frequency Standard. The equipment configuration for this measurement is shown in Figure 3-2.

If the oscilloscope pattern moves to the right, the counter's time base oscillator frequency is low compared to that of the standard; if the pattern moves to the left, the counter frequency is high.

Rate of movement can be interpreted in terms of frequency error in this way: With a 1 MHz signal from the standard used to trigger the display of a 10 MHz signal from the counter's internal oscillator, the time required for the pattern to apparently drift the width of one cycle of the display is noted. Suppose that the pattern drifts left the width of one cycle in a time of 10s; this is equivalent to a frequency difference of 0.1 cycle per second. Frequency error, then is 1 part in 10^8 (high):

$$\frac{\Delta f}{f} = \frac{0.1}{10^7} = 1 \times 10^{-8}$$

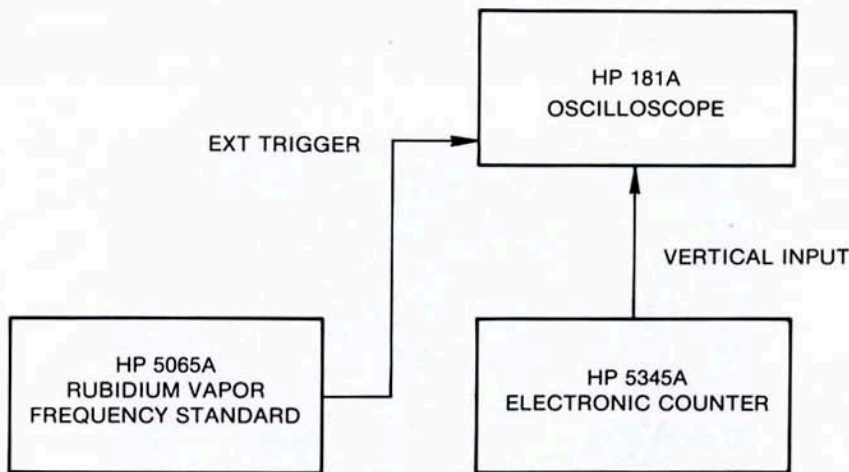

Figure 3-2. Oscilloscope Pattern Drift

* J. Czech, "The Cathode Ray Oscilloscope" Clever-Hume Press, Ltd., London 1957. See also: Rider and Usland, "Encyclopedia on Cathode Ray Oscilloscopes", Rider, Inc., New York, 1959.

If it takes 100 seconds for the pattern to drift the width of one cycle, the error is 1 part in 10^9 .

$$\frac{\Delta f}{f} = \frac{0.01}{10^7} = 1 \times 10^{-9}$$

If two 100 kHz signals are being compared and movement the width of one cycle takes 1 s, the frequency error is 1 part in 10^5 ,

$$\frac{\Delta f}{f} = \frac{1}{100 \times 10^3} = 1 \times 10^{-5}$$

Each of the above measurements can be made more quickly, but with less accuracy, by letting the pattern drift the width of $1/2$ cycle on the oscilloscope. Since many oscilloscopes have a calibrated display there is a temptation to take advantage of this in trying to shorten the observation time still further. Caution should be exercised, however, as inaccuracies in calibration and non-linearity in the display of the oscilloscope can distort the frequency error.

With the oscilloscope pattern drift method, as in the Lissajous method, the largest error will come from the method used for timing. A recommended technique for both of these frequency difference measurements is to adjust the oscillator being tested until there is no apparent movement on the oscilloscope. The resolution of this zeroing adjustment can be extended by orders of magnitude by setting the oscilloscope vertical gain to maximum and increasing the horizontal sweep speed until a single sloping portion of the waveform is visible on the screen. The frequency adjustment being made can be used to slow the phase so that the scope trace remains on screen while raising the horizontal sweep speed. A method of determining $\Delta f/f$ directly, quickly, and with greater accuracy is discussed below.

DIRECT FREQUENCY COMPARISON WITH A COUNTER

This section assumes the reader is familiar with the use and operation of a basic frequency counter whose measurement is cycles sensed per unit time. The details of basic counter measurements are covered in the Operating Manual for such instruments as the 5328A and in Hewlett-Packard AN 172, The Fundamentals of Electronic Frequency Counters.

The frequency counter is an instrument which can be used to measure the frequency of an oscillator with reasonable accuracy. A direct frequency measurement by a counter is in essence a comparison of two oscillators, the oscillator being measured and either the internal oscillator of the counter or an external frequency reference.

The HP 5345A Electronic Counter can be used to accurately compare two oscillators. As with any counter the accuracy of the measurement depends upon the error involved. Counter error consists of three parts:

- a. \pm Least Significant Digit (LSD) count;
- b. \pm Time base accuracy (accuracy of interval or external oscillator); and
- c. \pm Trigger error.

For the 5345A the LSD error is ± 1 count if the most significant digit (MSD) is 1 through 4, and ± 2 counts if the MSD is 5 through 9. Unlike conventional counters, the $\pm 5345A$ LSD count error relates to the 500 MHz time count register rather than in terms of one cycle of the input frequency. Therefore, with a 100 kHz input and a GATE TIME of 1 second, this error is only 1×10^{-8} ; furthermore, with the 5345A, this \pm count error remains constant for any input frequency for a fixed GATE TIME.

Trigger error is associated with the input signal and changes with waveform and measurement time. Trigger error in the 5345A is basically the same as a conventional counter measuring period or multiple period average and is specified as:

$$\frac{<0.3\%}{\text{number of periods averaged}}$$

for a 10 mVrms input sine wave signal with sine wave noise more than 40 dB below signal level.

For a 5 MHz signal with a 1 second GATE TIME the trigger error is less than $\pm 6 \times 10^{-10}$. Trigger error can be reduced by either increasing the amplitude of the input signal above the 10 mV rms minimum or by measuring a fast rise-time signal if available.

Error in the crystal oscillator "clock" frequency directly influences the accuracy of a measurement as it does for a conventional counter. The standard 5345A uses the HP high stability 10544A 10 MHz crystal oscillator which has an aging rate of $\pm 5 \times 10^{-10}$ /day and very good short-term stability. This oscillator satisfies most applications requiring the highest internal time base stability available in any counter manufactured.

The 5345A counter contains circuitry to lock the internal oscillator to any externally connected frequency standard at a subharmonic of 10 MHz in the range of 1 MHz to 10 MHz to give the same time base accuracy as the reference standard.

If a HP 5061A Cesium Beam Frequency Standard is used as the reference standard, the 5345A can be used to make very accurate frequency comparisons with convenient measurement times. If we assume worst case on the 5061A accuracy, the reference standard error will be less than $\pm 1 \times 10^{-11}$ of the international definition of frequency. Let us now measure a 5 MHz signal of 10 mV minimum using a 1 second, 10 second, 100 second, and 1000 second gate time. The equipment setup is as shown in Figure 3-3. For a 1 second gate time, the maximum error would be

$$\begin{aligned} \text{Error Max} &= \pm \text{count} \pm \text{trigger error} \pm \text{oscillator error} \\ &= \pm 2 \text{ counts} \pm \frac{0.3\%}{5 \times 10^6} \pm 1 \times 10^{-11} \\ &= \pm 4 \times 10^{-9} \pm 6 \times 10^{-10} \pm 1 \times 10^{-11} \\ &= \pm 4.61 \times 10^{-9} \end{aligned}$$

For a 10 second gate time

$$\begin{aligned} \text{Error Max} &= \pm 2 \text{ counts} \pm \frac{0.3\%}{5 \times 10^7} \pm 1 \times 10^{-11} \\ &= \pm 4.7 \times 10^{-10} \end{aligned}$$

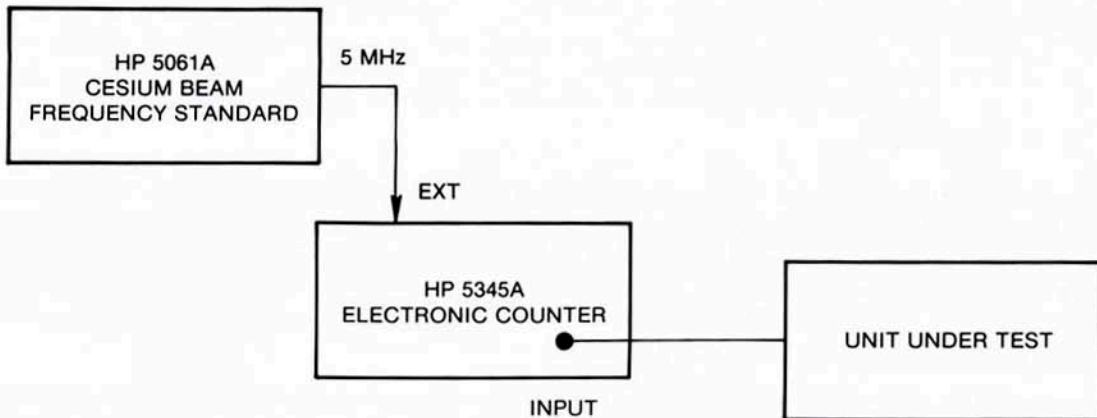

Figure 3-3. Direct Frequency Comparison with a Counter

For a 100 second gate time

$$\begin{aligned}\text{Error Max} &= \pm 2 \text{ counts} \pm \frac{0.3\% \pm 1 \times 10^{-11}}{5 \times 10^8} \\ &= \pm 4 \times 10^{-11} \pm 6 \times 10^{-12} \pm 1 \times 10^{-11} \\ &= \pm 5.6 \times 10^{-11}\end{aligned}$$

For a 1000 second gate time

$$\begin{aligned}\text{Error Max} &= \pm 4 \times 10^{-12} \pm 6 \times 10^{-13} \pm 1 \times 10^{-11} \\ &= \pm 1.46 \times 10^{-11}\end{aligned}$$

DIRECT COUNTER READOUT OF NORMALIZED OR FRACTIONAL FREQUENCY ERROR

Where a number of comparisons of precision oscillators expected to agree in frequency within parts in 10^6 (or better) is to be made against the reference frequency standard, it is convenient to arrange equipment so that a counter's readout can be interpreted directly in terms of frequency error to an accuracy of parts in 10^6 , 10^7 , 10^8 , etc. The equipment arrangement to accomplish this direct readout includes a reference oscillator offset from the reference standard by a predetermined amount.

The offset frequency from the reference oscillator and the frequency from the oscillator under test are mixed and the period of their difference frequency is measured. Such a comparison constitutes a short-term stability measurement; the changes in period of the difference frequency indicate the instabilities of the test oscillator and the measuring system including the reference frequency. The period displayed on the counter's readout can easily be interpreted (digit by digit from left to right) as frequency error (for example, parts in 10^6 , 10^7 , etc.).

To illustrate this method, assume a quartz oscillator's 1 MHz output is to be compared with the output of an offset oscillator. The system shown in Figure 3-4 is set up and calibrated by momentarily substituting a known 1 MHz signal (from the house standard) for the output of the oscillator under test. The HP Model 105A/B Quartz Oscillator serving as an offset standard is adjusted in frequency until the counter display is exactly 1,000,000.0 μs , the period of 1 Hz.

The 105A/B Oscillator is now at a frequency of either 1,000,001.0 Hz or 999,999.0 Hz; but more important it is 1 Hz from the known 1 MHz signal. The known signal is now removed from the mixer input and the output of the 1 MHz oscillator under test is applied in its place. If the test oscillator is at the same frequency as the 1 MHz calibration signal the counter will again read 1,000,000.0 μs . If it does not, its error can read directly to parts in 10^x as illustrated in the following example. If the counter's BCD output is converted to analog form and plotted on a strip chart recorder, a plot of $\Delta f/f$ with respect to time is obtained.

As an example, to compute what fractional frequency deviation is indicated for the oscillator under test when the period displayed on the counter's readout is observed to change by one microsecond, the following approximate method can be used:

$$f = \frac{1}{\tau} = \tau^{-1}$$

Where:

f = frequency, Hz

τ = period, s

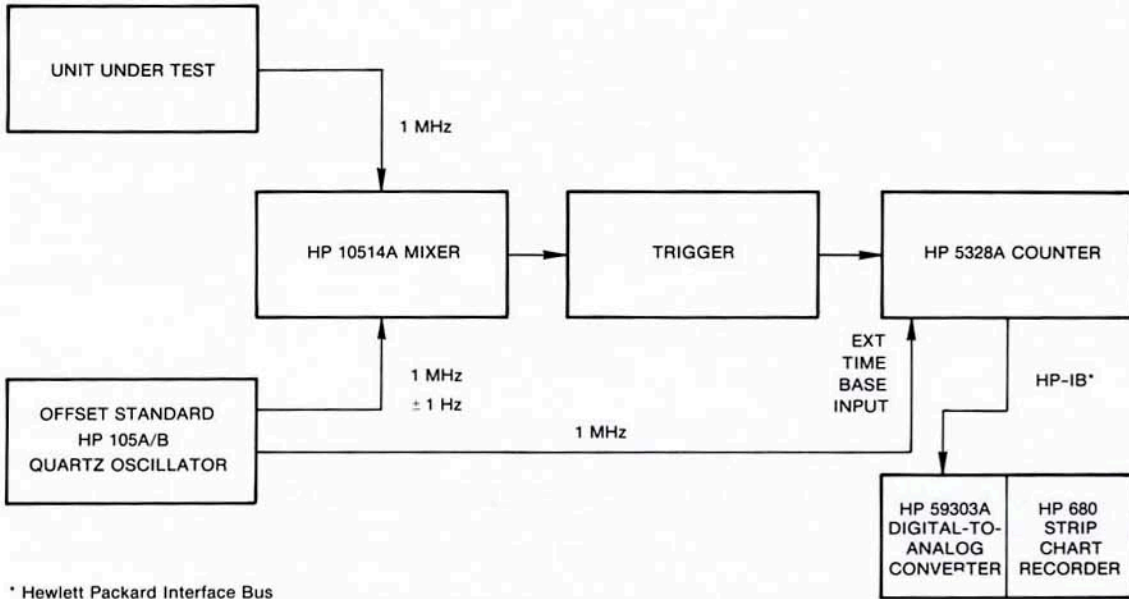

Figure 3-4. Direct Counter Readout of Fractional Frequency Error

Differentiating:

$$df = -\tau^{-2} d\tau = -\frac{d\tau}{\tau^2}$$

Dividing both sides by frequency:

$$\frac{df}{f} = -\frac{d\tau}{\tau^2 f}$$

Which for small changes can be approximated as:

$$\frac{\Delta f}{f} = -\frac{\Delta \tau}{\tau^2 f}$$

With the following interpretation:

$\frac{\Delta f}{f}$ = Fractional frequency offset in the frequency being checked

$\Delta \tau$ = Change in the period displayed on the counter

τ = Period of input signal to the counter (difference frequency)

f = Frequency being checked

With the substitution of values:

$$\Delta \tau = 1 \mu s = 10^{-6} s$$

$$f = 1 \text{ MHz} = 10^6 \text{ Hz}$$

$$\tau = 1 \text{ s}$$

$$\frac{\Delta f}{f} = -\frac{10^{-6}}{\tau^2 (10^6)} = -\frac{10^{-6}}{(1)^2 10^6} = -10^{-12}$$

Thus, when the period displayed on the counter is observed to change by $1\mu\text{s}$, the fractional frequency deviation is indicated to be one part in 10^{12} . This $\Delta f/f$ is attributed to the oscillator under test. The reference oscillator (and the system) are assumed to be ideal.

Note that this development has neglected measurement system jitter and counter resolution. Period measurements are subject to trigger errors even if the mixing frequency and the counter frequency are known exactly. Although resolution is on the order of 1 part in 10^{12} , absolute accuracy to this level would require great care and is more readily accomplished with other methods.

Using the figures from the above example, the period displayed on the counter's readout can be interpreted in terms of fractional frequency deviation as follows:

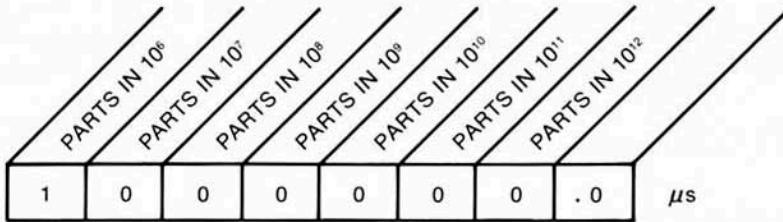

By use of this same technique it may be desirable to compare two 5 MHz frequencies. Using the equations previously developed, the period (inverse of the offset frequency) that should be measured is easily determined.

$$\frac{\Delta f}{f} = \frac{\Delta \tau}{\tau^2 f}$$

Solving for τ :

$$\tau = \sqrt{\frac{\Delta \tau}{f \left(\frac{\Delta f}{f} \right)}}$$

If the desired measurement is 1 part in 10^{12} for a $1\mu\text{s}$ change in the period measurement display column, then:

$$\frac{\Delta f}{f} = 1 \times 10^{-12}$$

$$\Delta \tau = 10^{-6} \text{ s}$$

$$f = 5 \times 10^6 \text{ Hz}$$

Substituting:

$$\tau = \sqrt{\frac{10^{-6}}{(10^{-12})(5 \times 10^6)}} = \sqrt{\frac{1}{5}}$$

$$= 0.4472135 \text{ s}$$

The offset frequency determined from the desired offset period measurement would be (approximately) 2.25 Hz in order to have a $1\mu\text{s}$ change equivalent to a $\Delta f/f$ of 1 part in 10^{12} .

FREQUENCY COMPARISON WITH A VECTOR VOLTMETER

Another method of rapid, accurate frequency comparison involves the use of a vector voltmeter to measure the phase shift versus time between two signal sources. With this method, frequency differences as small as 1 part in 10^{13} can be measured in a few minutes.

Figure 3-5 shows the HP Model 8405A Vector Voltmeter used in a system to compare and record the frequency difference between an HP 5061A Cesium Beam Frequency Standard and an HP 105A/B Quartz Oscillator under test. The phase of the signal from the reference 5061 is compared to the phase of the oscillator's signal and indicated on the 8405A's phasemeter. A dc recorder jack on the rear panel of the 8405A provides a voltage output proportional to the phasemeter reading.*

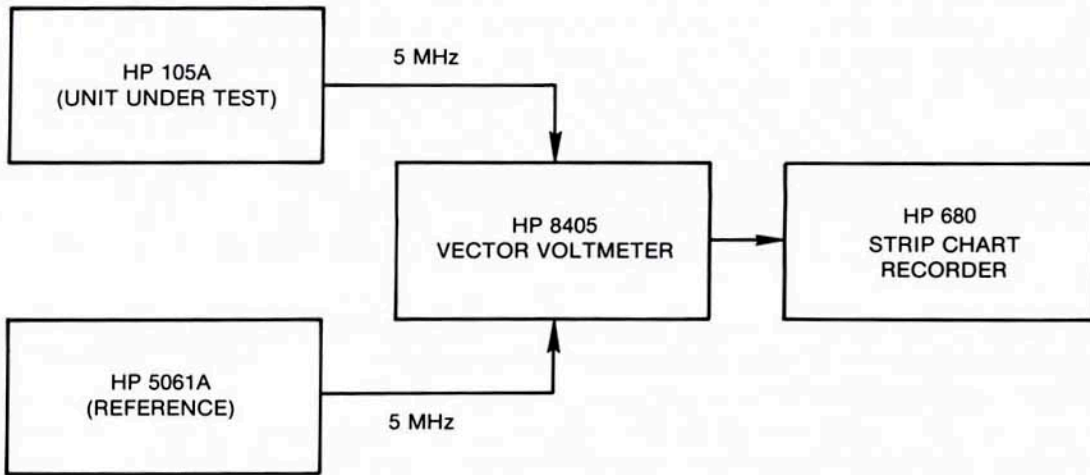

Figure 3-5. Frequency Comparison with a Vector Voltmeter

The phase change and direction can be recorded over a known period of time using a Model 680 Strip Chart Recorder as shown in Figure 3-5. Frequency difference, in proportional parts, can then be calculated and read from the calibrated recorder's output.

The phase angle between two signal sources changes by 360° every second for each cycle (Hz) of their difference in frequency. Stated in another form:

$$\frac{360^\circ/\text{s}}{1 \text{ Hz}} = \frac{\Delta\phi/t}{\Delta f}$$

Solving for Δf ,

$$\Delta f = \frac{\Delta\phi}{360 t}$$

Dividing by f ,

$$\frac{\Delta f}{f} = \frac{\Delta\phi}{360 t f}$$

Where:

Δf = frequency difference between the two signal sources, Hz.

f = frequency of the standard source, Hz.

$\Delta\phi$ = phase change in degrees during the measurement time.

t = time, in seconds, during which $\Delta\phi$ was measured.

$\frac{\Delta f}{f}$ = fractional frequency offset of the source being checked, dimensionless.

* HP Application Note 77-2, "Precision Frequency Comparison."

Example Measurement and Calculation for Setup in Figure 3-5:

$f = 5 \text{ MHz}$, frequency at which phase changes are measured.
 $\Delta\phi$ measured with 8405A = 1.3°
 $t = 60 \text{ seconds}$

$$\frac{\Delta f}{f} = \frac{1.3^\circ}{360^\circ (60 \text{ s}) (5 \times 10^6 \text{ Hz})}$$
$$= \frac{1.3}{1.08 \times 10^{11}} = 1.2 \times 10^{-11}$$

or 1.2 parts in 10^{11} .

During the measurement in this example, the 1.3° phase change observed was the result of a clockwise movement of the phasemeter's indicator. This is interpreted as showing that the test oscillator's signal on the "Channel B" input of the 8405A was leading the standard's signal on the "Channel A" input. Therefore, the test oscillator's frequency was higher than the standard's frequency by 1.2 parts in 10^{11} .

In general, the frequency difference between two oscillators is determined from the slope of phase change versus time. Therefore the phase slope at any time will be proportional to the instantaneous frequency difference between the two oscillators. A constant frequency offset appears as a linear phase versus time trace. A linear drift in frequency results in a parabolic trace.

FREQUENCY COMPARISON WITH A PHASE COMPARATOR AND STRIP CHART RECORDER

Long term frequency comparison of two signal sources can be accomplished quite simply using the system shown in Figure 3-6. The primary component in this system is the HP Model K05-5060A Linear Phase Comparator.

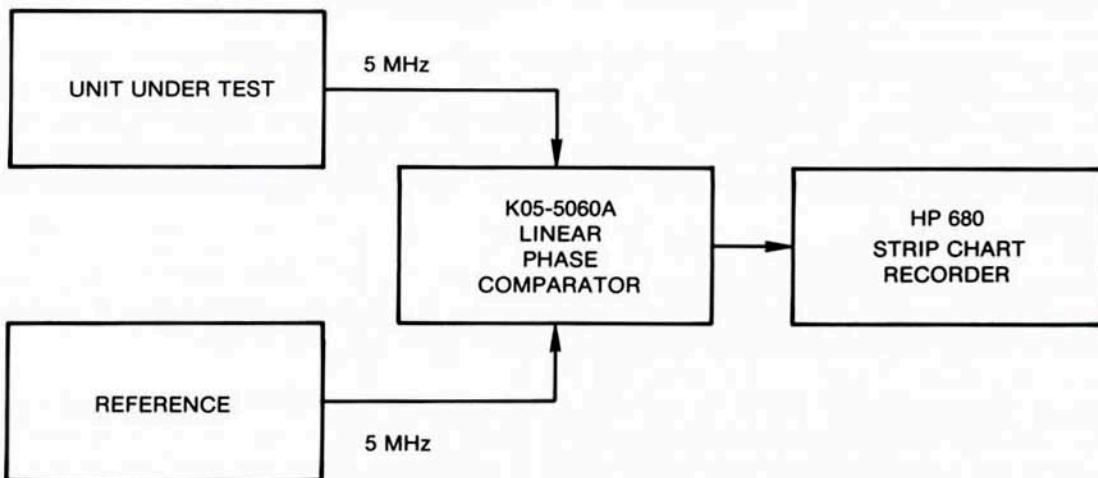

Figure 3-6. Frequency Comparison with a Phase Comparator

Because of its simplicity, understanding this method of frequency comparison merely requires an understanding of the operation of the K05-5060A. There are two input channels, one of which serves as the input for a standard signal and the other as an input for the test oscillator. A single selector switch is set at the comparison frequency; either 100 kHz, 1 MHz, or 5 MHz.

Internally, the signals on each of the two channels are compared and control the on/off duty cycle of a flip-flop circuit. The rectangular wave output from this circuit is then integrated to give an output dc signal which is proportional to the phase difference between the two input signals.

After a simple calibration of the system shown in Figure 3-6, the full scale width of the recorder chart is equal to the period of the input frequency. When comparing two 1 MHz frequencies, for example, the chart width would be 1 μ s.

To compute the frequency error of the test oscillator the following relationship is used:

$$\left| \frac{\Delta f}{f} \right| = \left| \frac{\Delta t}{t} \right| = \left| \frac{\Delta \phi}{\phi} \right|$$

Which is derived in Appendix F and where,

$\frac{\Delta f}{f}$ = fractional frequency deviation of test oscillator

Δt = the measured phase difference, in microseconds

t = the elapsed measurement time, in microseconds

For example, if the recorder chart indicates a full width variation (1 μ s for a 1 MHz signal) during an elapsed measurement time of 1 hour, the frequency error of the test oscillator is:

$$\begin{aligned} \left| \frac{\Delta f}{f} \right| = \left| \frac{\Delta t}{t} \right| &= \frac{1 \mu\text{s}}{(60 \text{ min/hr}) (60 \text{ s/min}) (1 \times 10^6 \mu\text{s/s})} \\ &= 3.2 \times 10^{-10} \end{aligned}$$

or 3.2 parts in 10^{10} frequency error.

FREQUENCY DETERMINATION FROM TIME COMPARISONS

Before stabilized LF/VLF (Loran, Omega, etc.) transmissions were available for use in a quick and accurate calibration of a local frequency standard, it was common practice to use time ticks from a high frequency standard station such as WWV for this purpose. This time comparison method for determining frequency has fallen into disuse because it is neither quick nor convenient. In those rare cases where no access exists to LF/VLF standard signals, this method could still serve.

In the time comparison method, frequency is measured indirectly. Observations are made over an extended period of time in order to minimize errors arising from variations in propagation; overall accuracy depends on signal conditions and on the length of the test.

Suppose the local clock is driven by a precision oscillator and that its time is periodically compared with the master time by methods such as those described in Section IV. If the time intervals of the local clock precisely match those of the master clock, the oscillator frequency is precisely its nominal value. If the clock loses time, the oscillator frequency is low, if it gains time, the oscillator frequency is high.

Direct Computation. The average oscillator frequency (or average frequency error) during the elapsed time between two time comparison measurements is easily computed.

Average fractional error in frequency is equal to the fractional time error and is given by

$$\left| \frac{\Delta f}{f} \right| = \left| \frac{\Delta t}{t} \right| = \frac{t_2 - t_1}{t}$$

where $\frac{\Delta f}{f}$ = average frequency error

t_1 = initial time-comparison reading

t_2 = final time-comparison reading

t = elapsed time between readings.

Example: A time comparison reading at 10:00 a.m. on June 1 is 563,060 μ s; a reading at 10:00 a.m. on June 4 is 564,040 μ s. In this case;

$$\frac{\Delta f}{f} = \frac{564,040\mu\text{s} - 563,060\mu\text{s}}{3 \text{ days}} \times \frac{1 \text{ day}}{8.64 \times 10^{10}} = \frac{+3.8}{10^9}$$

That is, the average oscillator frequency error during this period is 3.8 parts in 10^9 high.

Average frequency of an oscillator during the measurement interval is given by

$$f_{av} = f_{nom} \left(1 + \frac{\Delta f}{f} \right)$$

where f_{av} = average frequency

f_{nom} = nominal oscillator frequency

$\frac{\Delta f}{f}$ = average frequency error

Continuing with the example given before for an oscillator with a nominal frequency of 1 MHz,

$$f_{av} = 10^6 \left(1 + \frac{3.8}{10^9} \right) = 1,000,000.0038 \text{ Hz}$$

Note that determination of oscillator frequency depends on measurement of time intervals, and does not depend on absolute time setting or time synchronization with the master time source. Because of the use of "leap seconds" in the UTC system, this technique can give erroneous results if one does not account for the leap seconds.

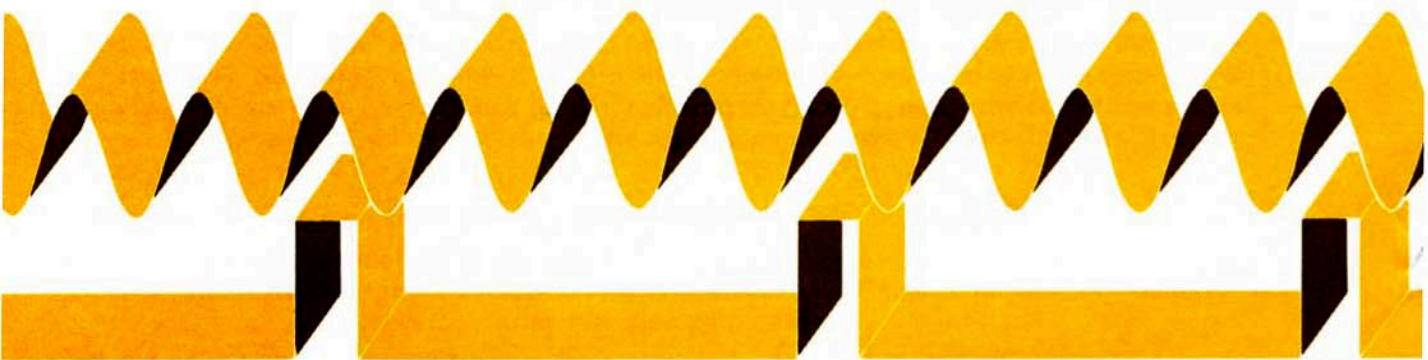

SECTION IV

TIME AND FREQUENCY TRANSFER

In this section we discuss several methods available for transferring time and frequency from one location to another. Transfer of time is usually referred to as "time synchronization" whereas frequency transfer is termed "calibration". Since synchronization normally implies that calibration is also accomplished, for this discussion the term synchronization is intended to include both time synchronization and frequency calibration.

As was mentioned in Section I, synchronization can be either relative or absolute. In absolute synchronization, the user or operator of a clock or clocks references them to the internationally defined frequency as well as UTC. This requires that the clock is traceable to a national laboratory which contributes to the internationally Coordinated Universal Time (UTC) scale. AN 52-1, Fundamentals of Time and Frequency Standards, contains a listing of national laboratories around the world.

In relative synchronization, the user has several clocks or standards which must be kept close to each other in frequency or time, but have no concern with absolute time reference because there is no need to interface with clocks or standards outside his system.

We can also refer to "real" synchronization or "paper" synchronization. "Real" synchronization refers to the situation where the local clock is actually adjusted to the correct frequency and time. "Paper" synchronization refers to measuring the differences in frequency and time between local and reference clocks but no adjustments are made. "Real" synchronization is normally performed in systems using quartz or rubidium standards because of their characteristic frequency drift. "Real" synchronization can also be performed with cesium standards; however, "paper" synchronization is more common in order to preclude human error that sometimes occurs whenever operator intervention is allowed. The lack of frequency-drift in cesium frequency standards makes this convenient.

The criteria for selecting either "real" or "paper" synchronization is the maximum amount of error in either time or frequency which is tolerable in the system. The larger the error-tolerance, the less often "real" synchronization need be performed. Interim measurements may be made between adjustments to provide additional confidence in the system and insure that nothing catastrophic has occurred in the meantime. Obviously, the frequency of interim measurements and periodic "real" synchronization is dependent upon the error-tolerances, accuracy and drifts in the system, costs of measurements and synchronization, and the level of confidence the user requires in the system operation.

Several popular methods for accomplishing time synchronization and frequency calibration are contained in the following paragraphs.

COMPARISON OF VARIOUS TIME AND FREQUENCY TRANSFER TECHNIQUES

Table 4-1 is useful in comparing the salient characteristics of several time and frequency transfer techniques. The table is intended to show the relative merits of each technique and is not intended to provide absolute limits on their performance. Additional information on each technique is contained in the sections that follow, as well as the references listed in the bibliography.

Table 4-1. Comparison of selected time/frequency transfer techniques.
 Courtesy of National Bureau of Standards (NBS Monograph 140, p.301)

TRANSFER TECHNIQUES		STATUS (1)	ACCURACY OF FREQUENCY SYNCHRONIZATION	ACCURACY FOR DATE TRANSFER	AMBIGUITY (4)	COVERAGE FOR STATED ACCURACY	% OF TIME AVAILABLE	RELIABILITY	RECEIVER COST FOR STATED ACCURACY	COST PER CALIBRATION	NUMBER OF USERS THAT CAN BE SERVED	OPERATOR SKILL REQUIRED FOR STATED ACCURACY
VLF RADIO	COMMUNICATION/SFB GBR, NBA, WWVL	O	1-10 ¹⁰	ENVELOPE 500 μs	PHASE ~50 μs	GLOBAL						
	NAVIGATION SYSTEM OMEGA	O/P	<1-10 ¹¹	≤ 10 μs	PROPOSED CODE 1 YR PHASE ~100 μs	GLOBAL				MODERATE		TIME CODE
LF RADIO	STANDARD FREQ. BROADCAST (WWVB)	O	1-10 ¹¹ (PHASE 24h)	ENVELOPE ~1 ms	1 YR	USA (WWVB) LIMITED				MODERATE		USA (WWVB) EUROPE OTHERS
	NAVIGATION SYSTEM LORAN C	O	1-10 ¹² GND	~1 μs (GND) 50 μs (SKY)	50ms PHASE 10 μs	SPECIAL ♦ AREAS						SPECIAL AREAS
HF/MF RADIO	STANDARD FREQ. BROADCASTS (WWV)	O	1-10 ⁷	1000 μs	1 DAY 0.5 min	HEMISPHERE			DEPENDS ON CONDITIONS			
	NAVIGATION SYSTEM LORAN A	O	5-10 ¹⁰	2.5 μs NOT UTC		LIMITED AREAS			DEPENDS ON CONDITIONS			SPECIAL AREAS
TELEVISION (VHF/SHF RADIO)	PASSIVE LINE 10	O	1-10 ¹¹ (24h)	~1 μs	1 DAY ~33ms	NETWORK COVERAGE	"LIVE" PROGRAMS					USA FOR EXAMPLE
	ACTIVE LINE 1 (NBS TV TIME SYSTEM)	E	1-10 ¹¹ (<30 min)	<100ns	1 DAY ~33ms	NETWORK COVERAGE						USA FOR EXAMPLE
SATELLITES (VHF/UHF/SHF RADIO)	STATIONARY SATELLITES (TRANSPONDER) ONE WAY	E/O	1-10 ¹⁰ (24h)	10-50 μs	DEPENDS ON FORMAT	HEMISPHERE	STATIONARY					
	STATIONARY SATELLITES (TRANSPONDER) TWO WAY	E/O	1-10 ¹² (24h)	~100ns	DEPENDS ON FORMAT	HEMISPHERE				MODERATE		
	ON BOARD CLOCK (ACTIVE) ONE WAY - LOW ALTITUDE	O	~1-10 ¹⁰ (24h)	0.5-50 μs	DEPENDS ON FORMAT	WORLD	10-15 min PER PASS 2-4 PER DAY	CLOCK NEEDS ADJUSTMENT				
SHF RADIO	MICROWAVE	E/O	~1-10 ¹³ (PER WEEK)	≤ 100ns	PHASE COMPARISON	LOCAL LINKS						
	VLBI	P	5-10 ¹⁴	~1ns	DEPENDS ON FORMAT	HEMISPHERE	AS NEEDED					
PORTABLE CLOCKS	PHYSICAL TRANSFER	O	1-10 ¹²	100ns	1 DAY	LIMITED BY TRANSPORTATION	AS NEEDED		NONE			
	AIRCRAFT FLYOVER 2 WAY	E	1-10 ¹²	≤ 100ns	DEPENDS ON FORMAT	LIMITED BY TRANSPORTATION	AS NEEDED					
PULSARS	OPTICAL SIGNAL → NP 0532	P	1-10 ¹⁰	~10 μs	~33ms	HEMISPHERE	NIGHTTIME					
AC POWER LINE	POWER NETWORK SYSTEM	P	1-10 ⁸	~1ms	16.7ms	CONTINENTAL USA				MINIMAL	MINIMAL	CONTINENTAL USA

NOTES: (1) Status of technique indicated as follows: O—Operational; P—Proposed; E/O—Experimental operational. (2) Estimates of day-to-day measurements within 2000 km (1250 mi) of Loran-A stations. These emissions not coordinated with UTC and manually operated crystal clocks drift. (3) From day-to-day phase measurements e.g., 1 μs per day phase change approximates 1 pt. in 10¹¹ in frequency difference. (4) Left-hand designation gives the shortest time interval that cannot be resolved; Right-hand number gives basic ambiguity. ♦, by ground wave 1600 km; by sky wave thousands of kilometers depending upon conditions. ■, with proposed time code. ●, closure after 1 day. ▲, within local service area of TV transmitter and path delay known.

Here is a further amplification on some of the characteristics listed in the table. ACCURACY OF FREQUENCY SYNCHRONIZATION refers to the uncertainties inherent in the medium which limit the accuracy to which frequency standards can be synchronized or calibrated.

ACCURACY FOR DATE TRANSFER is the accuracy to which time-of-day can be transferred or synchronized at a given location. The values given are average values and must be adjusted for either extremely favorable or unfavorable conditions.

AMBIGUITY is the coarsest time interval a time-transfer can provide directly with certainty. For example, an ordinary wall clock has an ambiguity of 12 hours. One must know by other means the year, month, day, and whether it is AM or PM, the clock does the rest.

The qualitative ratings of good, fair and poor in the chart are given for purposes of comparison and evaluation and as such are arbitrary and broad.

HIGH FREQUENCY TRANSMISSIONS

General characteristics of high frequency and low frequency propagation were discussed in AN 52-1 where it was pointed out that high frequency signal propagation is subject to erratic variations, particularly, phase delays. These and other problems can usually be eliminated by the use of LF ground wave and satellite signals.

An AM receiver, tunable to the needed frequencies (for WWV: 5, 10, and 15 MHz) is the basic requirement. The receiver's capability and complexity (hence cost) depends upon the degree of precision demanded of the measurement and upon the received signal strength at the user's location.

Accuracy. Generally, frequency transfers within the groundwave of HF transmissions (~160 km) can be made with the same accuracy as the transmitted signal. However, at distances using skywave paths, the accuracy is limited to 1×10^{-7} for frequency transfer and 1 ms for time transfer. Measurements over long periods of time can result in better accuracy using averaging techniques.

Advantages and Limitations. Use of HF transmissions offers several advantages to the user.

1. The receivers and antennas are relatively simple and low cost.
2. Stable HF signals are available worldwide from approximately 20 countries (a detailed listing of HF transmitters is contained in AN 52-1.).
3. Groundwave signals (~ 160 km from the transmitter) can be received with about the same accuracy as transmitted.
4. Time pulse modulation and date information is available at these frequencies due to the availability of sufficient bandwidth.

However, several limitations also exist which may limit the use of HF in some applications.

1. HF skywave signals suffer erratic excursions in time delay from ionospheric irregularities; this degrades both time and frequency comparisons and causes unreliability of reception. Use of long term averaging techniques can remove some propagation anomalies thereby approaching precisions of parts-in- 10^{10} but only over periods of 30 days or greater.
2. Propagation delays are difficult to determine to better than 1 ms because of ionospheric variability due to sunspots, time of day, seasons, distance, etc.
3. The number of hops propagated (transmission modes) is difficult to determine for paths exceeding 3500 km.

Time and Frequency Determination. For effective use of HF timing signals, it is important that certain precautions be observed to reduce the effects of the observable variations. For best results:

1. Schedule observation for an all-daytime or all-night-time transmission path between transmitter and receiver. Avoid twilight hours.
2. Choose the highest reception frequency which provides consistent reception.
3. Observe tick transmission for a few minutes to judge propagation conditions. The best measurements are made on days when signals show little jitter or fading. If erratic conditions seem to exist, indicated by considerable fading and jitter in tick timing, postpone the measurement. Ionospheric disturbances causing erratic reception sometimes last less than an hour, but may last several days.
4. Make time comparison measurements using the ticks with the earliest consistent arrival time (shortest distance mode).

One system for using HF signals is described in the following paragraphs.

TIME COMPARISON BY TICK PHASING ADJUSTMENT—Figure 4-1 shows a block diagram for a system to compare local time against time signals from an HF standard station such as WWV. The local frequency standard, an HP Model 105A/B Quartz Oscillator, drives an HP K09-59991A Clock. The K09-59991A derives a 1 PPS tick from the oscillator output, and it is these local ticks which trigger the oscilloscope sweep.

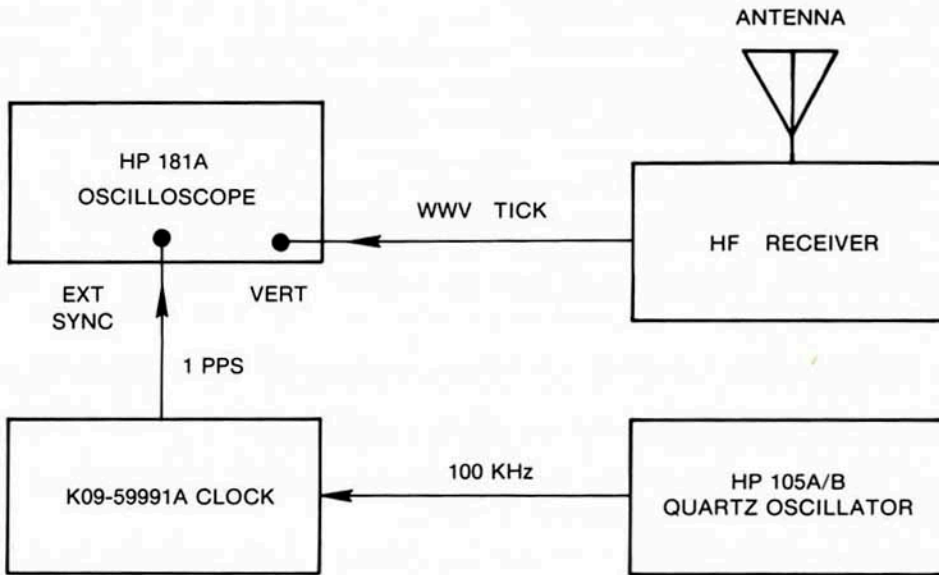

Figure 4-1. Time Comparison by Tick Phasing Adjustment

Upon initial observation, the local tick and the received tick, which is the master timing pulse, may be apart as much as a half second. With oscilloscope sweep time set at 1 sec or more, the WWV tick may be located with reference to the local tick. Adjustment of the Time Delay Thumbwheel switches on the K09-59991A delays the start of the oscilloscope sweep to bring the WWV tick toward the beginning of the oscilloscope trace. Successive adjustments of the Time Delay Thumbwheel and Oscilloscope sweep speed are made until the two ticks are brought to near coincidence (the Time Delay switch changes the phase of the K09-59991A tick without affecting oscillator frequency).

The WWV tick is a 5 ms pulse of a 1 kHz signal. It is this master timing pulse which is observed on the oscilloscope as the phasing of the local clock tick is shifted.

Once the two ticks have been brought into near coincidence, the calibrated Time Delay Switch gives the initial time reference between local time and the time of WWV. At this point the Time Delay Switch reading is logged. As the oscillator under test drifts with respect to the received time signals, the Time Delay Switch is readjusted to again establish near coincidence with the WWV tick. The amount of this readjustment (which indicates the time drift of the local oscillator) is again logged. These data, taken over a period of time and plotted, will enable accurate determination of drift rate and frequency error. Time comparisons made over several days can yield comparison accuracies of a few parts in 10^8 or better. Oscillator frequency can be readjusted to stay within the desired accuracy limits.

TICK AVERAGING—Since random variations in the propagation path cause variation in the arrival time of each WWV tick, the accuracy of time comparison measurements depends to a large extent on the operator's ability to judge tick arrival time. Excellent results can be obtained with the use of the variable persistence feature of the HP Model 141A or 181A Oscilloscopes. A 5 second persistence permits the operator to view repeated sweeps of WWV displayed together. From this display he can easily determine the time of earliest consistent tick arrival. An alternate method of tick averaging is to make an oscillogram using an HP Model 195A or 197A

Oscilloscope Camera or equivalent. Either method, variable persistence oscilloscope display or photographic time exposure, produces a record such as those shown in Figure 4-2. If oscilloscope sweep time has been calibrated accurately, a determination of the time comparison reading is possible.

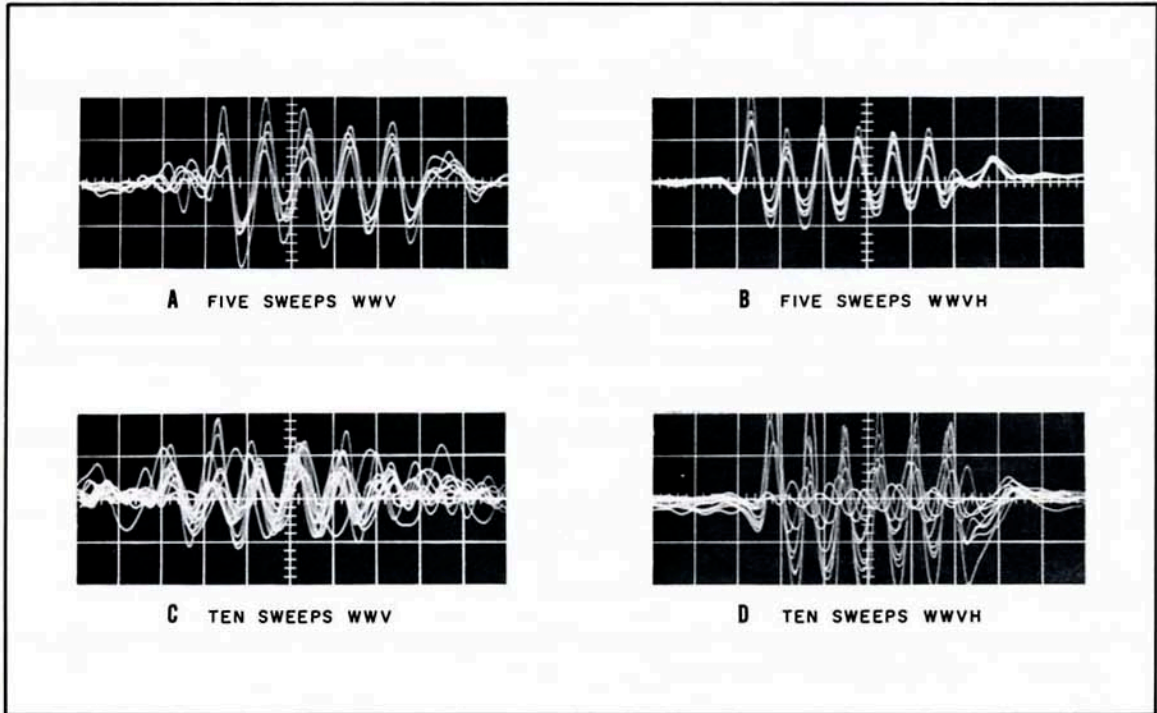

Figure 4-2. Photographic Tick Averaging

LOW FREQUENCY (LF) AND VERY LOW FREQUENCY (VLF) TRANSMISSIONS

Propagation of low frequency and very low frequency signals is discussed in AN 52-1. The phase stability and long range coverage of low frequency transmissions makes them particularly valuable for standard frequency broadcasts.

Variations in propagation conditions exist, and for accurate comparisons account must be taken of such variations as those associated with the diurnal shift (phase shifts occurring at sunrise and sunset). Factors affecting path phase velocity include ionospheric conditions and ground conductivity.

Since the phase velocity of long range VLF signals depends to an extent upon the effective height of the ionosphere, sudden ionosphere disturbances such as those occurring during solar flare events cause sudden phase anomalies. Other changes in VLF propagation are believed to relate to polar cap events, magnetic activity, nuclear explosions, and even to meteor showers.

Because relatively short periods serve for LF/VLF phase comparisons, diurnal phase shifts and other anomalies are not a serious problem, provided the user is aware of them.

Accuracy. A local frequency standard can be maintained to within a few parts in 10^{11} or better by comparison of its relative phase to that of a received LF or VLF carrier. Any one of a number of monitoring systems may be chosen to make this comparison possible, depending on the degree of precision required of the relative phase measurement. For the greatest precision, the local standard must have a low drift rate which is predictable to within a few parts in 10^{10} over several days.

If no better than a part in 10^8 is wanted, a nearly instantaneous direct comparison, for a short time, may be used. If a part in 10^9 is wanted, comparison must be continued long enough to reveal any ionospheric disturbance. Best results usually are obtained when the total propagation path is in sunlight and conditions are stable. Near sunrise and sunset there are noticeable shifts both in amplitude and in phase.

Advantages and Limitations. Major advantages to using LF or VLF time and frequency transmissions are:

1. Stable results are obtained within ranges to the transmitter of ~1600 km for LF and ~10000 km for VLF.
2. Single frequency comparisons can be made with relatively low cost equipment. Accuracies of parts in 10^{11} are possible over 24 hour periods most of the time.
3. Transmitters are usually stabilized with atomic standards and the transmissions are monitored by national laboratories which publish corrections that permit after-the-fact reference to their time scales.
4. Although LF and VLF signals are subject to diurnal effects, such phase changes are predictable and repeatable.
5. Time pulse modulation, which is possible with LF, permits time synchronization to ~100 μ s or better provided the propagation delay is known.

Major limitations of LF and VLF transmissions are:

1. Ionospheric anomalies degrade reception in some geographical areas of the world referenced to an individual transmitter
2. LF and VLF propagations are subject to ionospheric variations; phase changes occur from diurnal effects, solar disturbances, nuclear blast effects, night-time irregularities, and long vs. short path interferences; strong attenuation over ice fields; and cycle slips.
3. Extreme care is required for optimum results. Proper interpretation of data requires experienced personnel.
4. It is impossible to initially set remote clocks to high accuracy via LF techniques alone.
5. Atmospheric noise at VLF is quite high and coherent signals often must be detected well below the noise. Noise from lightning strokes is maximum in this frequency band and the low attenuation rates of atmospheric noise at VLF allows worldwide propagation of such static.

Time and Frequency Determination. Determination of frequency is relatively simple for LF and VLF transmissions. A receiver, a phase-locked oscillator, a phase comparator and a strip chart recorder are all that is needed to make accurate measurements. A typical setup is shown in Figure 4-3.

Time, in comparison, is difficult to accurately transfer using LF and VLF transmissions due to the slow rise times of the time codes, if present. However, once synchronized, a clock can maintain synchronization indefinitely with the transmitter simply by phase tracking the LF/VLF broadcasts. In the case of WWVB, the transmitted signal is phase controlled to the UTC time scale and, hence, a user can phase-lock to UTC with only one initial time setting.

Several methods for using LF and VLF transmissions for time and frequency comparisons exist. The simplest of these methods is the single frequency comparison. The single frequency comparison technique is basically the same for either LF or VLF, however, the receiver for VLF must have a very narrow bandwidth (~0.01 to 0.001 Hz) in order to extract the VLF signal from the noise level in this frequency band. Let us now look at the single frequency technique for frequency comparison.

In the continental U.S., frequency standard comparisons to an accuracy of a part in 10^{10} can be approached in an 8 hour period. A 30 day period may give accuracies of parts in 10^{12} . The local standard being calibrated must, of course, be of a quality commensurate with the realization of such high accuracies. NBS station WWVB, at Ft. Collins, Colorado, is kept to within a tolerance limit of 1 part in 10^{11} .

The receiver and comparator system phase track a voltage-controlled oscillator with the transmitted signal. The local frequency standard is then compared to the phase tracking oscillator. The comparator's strip chart recorder makes a continuous recording of the phase differences, measured in μs .

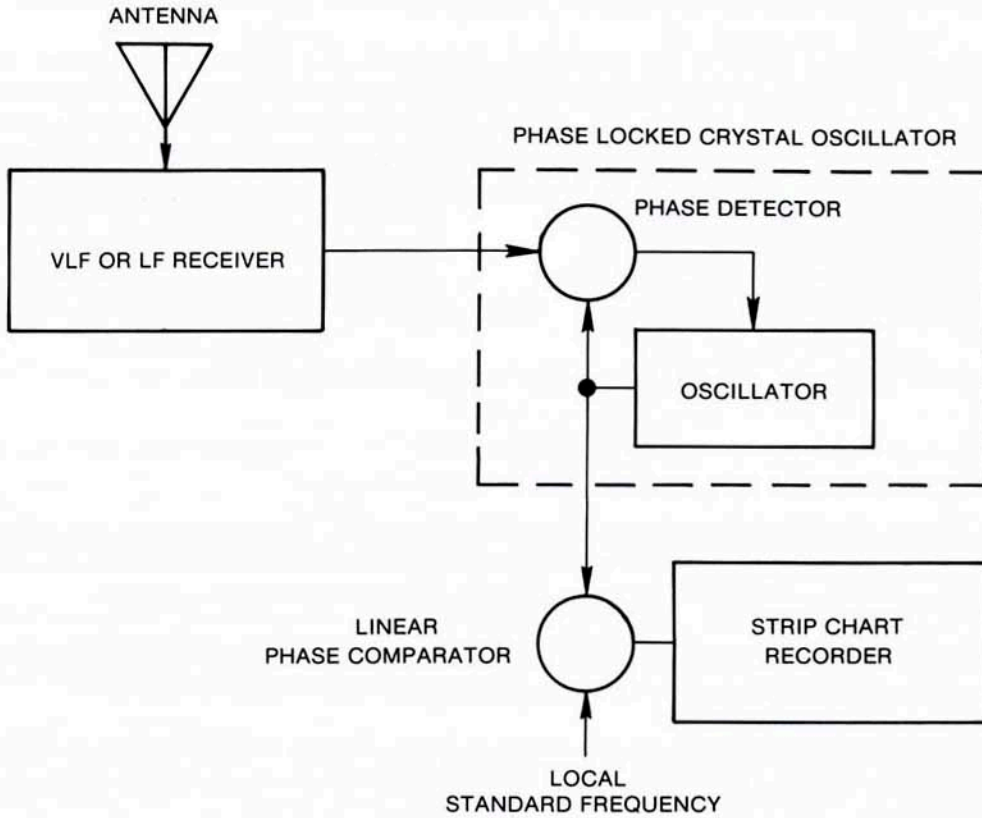

Figure 4-3. LF or VLF Frequency Determination

In operating the receiver-comparator, the user should always consider the system as a whole:

- 1) Transmitted signal;
- 2) Transmission path;
- 3) Receiver-comparator system;
- 4) Local standard.

The first two parts of the system are not under the user's control, so he must choose his observation time when a frequency standard signal is being transmitted and when transmission conditions are optimum. He should keep up to date on the NBS or other low frequency services by requesting to be placed on the appropriate mailing list of the transmitting agency (see AN 52-1).

Antenna location and orientation are important. Best location is on the roof of a building on the side facing the transmitter. The antenna should clear by 3 feet or more any metal structure, roof, etc.

The receiver-comparator plots the phase difference of a locally generated signal vs. that of the received carrier by means of a strip chart recorder.

It is possible to make frequency comparisons by measuring changes in phase, over a period of time, between a locally generated signal (from a quartz crystal oscillator, counter time base, etc.) and the received carrier. The fractional frequency offset of the local signal with respect to the received signal is equivalent to the change in the phase measured over a time interval. The receiver-comparator plots this phase difference as a function of time with, under laboratory conditions, a resolution better than 1 μ s of phase difference.

The slope of the trace made by the strip chart recorder is, at a given instant, proportional to the frequency offset between the local standard and the received signal $d\phi/dt$. It is possible to interpret the chart trace by selecting two points on the trace some distance apart in chart time and to read off the change. If N is the difference in μ s of two readings three hours apart, then N can be said to be the average frequency offset of the local oscillator in parts in 10^{10} . This is apparent from the following:

$$\frac{N \text{ microseconds}}{3 \text{ hours}} = \frac{N}{3(3600)10^6} = \frac{N}{10^{10}}$$

The fractional time error corresponds to the fractional frequency error:

$$\left| \frac{\Delta f}{f} \right| = \left| \frac{\Delta t}{t} \right| = \pm N \times 10^{-10}$$

OTHER LF/VLF SINGLE FREQUENCY TECHNIQUES—While no other LF or VLF comparison method offers the convenience and simplicity afforded by use of the receiver-comparator just described, there are a number of equipment arrangements which can be used.

Two methods are discussed here. One involves the use of an electronic counter in its time interval mode for the comparison and the other uses an oscilloscope display.

The system that employs a simple LF/VLF receiver, a time interval counter and other equipment, shown in Figure 4-4, could serve to determine the drift of a local standard such as a quartz crystal oscillator.

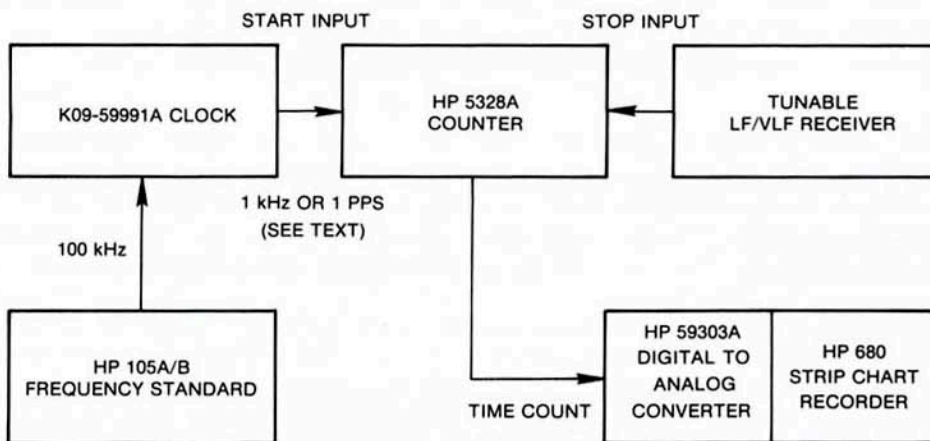

Figure 4-4. LF/VLF Comparison System Using a Counter

For example, suppose the 60 kHz signal from NBS station WWVB is to be the reference. The Model 105A/B Quartz Oscillator output drives the K09-59991A clock. The clock's 1 PPS output is used to start the interval count and the received 60 kHz carrier is used to stop it. The Model 5328A Counter's trigger level and slope controls permit the selection of precisely repeatable points on the start and stop waveforms. The Model 59303A Digital-Analog Converter and the Model 680 Recorder make, from the time interval counter's measurements, a continuous record from which the relative time-drift of the local oscillator can easily be determined.

A short calculation indicates that this method makes possible a comparison accuracy of a part in 10^9 or better in an hour. Since there are approximately 4×10^9 microseconds in 1 hour, a frequency difference of 1 part in 10^9 between the received signal and that from the local standard would result in a time drift of about 4 microseconds over a 1 hour measurement. This value is found to be well within the resolution of the equipment.

Calculation of the frequency error of the local standard can be made as described in Section III and is based upon the time drift of the average time interval readings.

A comparison method that, using an oscilloscope, makes possible a visual comparison of a local oscillator against LF/VLF signals and can be set up as shown in Figure 4-5.

The signal is received and amplified and is displayed on the oscilloscope (vertical axis), which is synchronized externally by a signal from the local standard being compared.

Comparison measurements are made by positioning the zero crossing of the waveform to some reference point on the oscilloscope and observing the amount and direction of drift over a period of time. A drift toward the right of the screen indicates that the frequency of the local standard is high, whereas a drift to the left indicates that the frequency is low. Average frequency error may be calculated from the following relationship:

$$\left| \frac{\Delta f}{f} \right| = \left| \frac{\Delta t}{t} \right|$$

where

$\frac{\Delta f}{f}$ = average frequency error

Δt = amount of drift during period T

t = comparison period

Comparison accuracy of this technique is determined by oscilloscope trigger stability, sweep calibration accuracy, and the user's ability to integrate and resolve Δt . It is not recommended that frequency standards with accuracy requirements better than several parts in 10^9 be calibrated by this method.

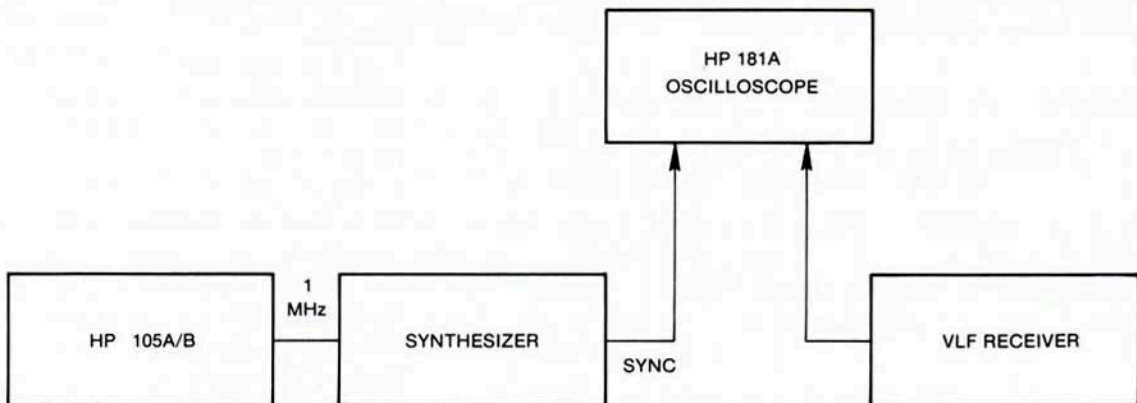

Figure 4-5. VLF/LF Comparison Using an Oscilloscope

LORAN C NAVIGATION SYSTEM

Loran-C (LOng RANge Navigation) is a navigation system, currently available in some parts of the Northern Hemisphere, designed to provide precise position for ships, submarines, and aircraft. Early in the 1960's NBS examined the Loran C navigation System to determine its usefulness in time and frequency distribution. Since then, the Loran-C transmitters have been cesium stabilized and today the system is one of the most accurate time transfer medium available via radio waves.

The Loran-C navigation system is operated by the U.S. Coast Guard. The carrier frequency is 100 kHz, with a 20 kHz bandwidth, and the transmission format uses pulsed transmission. There are currently 30 transmitting stations organized into seven chains, around the world. Expansion of coverage to new areas is underway, with Western U.S. coverage due in 1977. Each chain consists of one master station and two or more slave stations. Table 4-2 contains a listing of the seven Loran-C chains.

Table 4-2. Loran-C Stations

CHAIN	RATE	STATIONS	
U.S. East Coast	9930	M	Carolina Beach, NC
		W	Jupiter, FL
		X	Cape Race, NF
		Y	Nantucket Is., MA
		Z	Dana, IN
Mediterranean	7990	M	Simeri Crichi, Italy
		X	Lampedusa, Italy
		Y	Kargabarun, Turkey
		Z	Estartit, Spain
Norwegian Sea	7970	M	Ejde, Faroe Is.
		W	Sylt, Germany
		X	Bo, Norway
		Y	Sandur, Iceland
		Z	Jan Mayen, Norway
North Atlantic	7930	M	Angissoq, Greenland
		W	Sandur, Iceland
		X	Ejde, Faroe Is.
		Z	Cape Race, NF
North Pacific	5930	M	St. Paul, Pribiloff Is.
		X	Attu, AK
		Y	Port Clarence, AK
		Z	Sitkinak, AK
Central Pacific	4990	M	Johnston Is.
		X	Upolo Pt., HI
		Y	Kure, Midway Islands
Northwest Pacific	9970	M	Iwo Jima, Bonin Islands
		W	Marcus Island
		X	Hokkaido, Japan
		Y	Gesashi, Okinawa
		Z	Yap, Caroline Islands

*Approximate value

The repetition rates used in the Loran-C pulse code format provide three basic benefits:

1. The chains and the individual stations can be separated and identified.
2. Coherent stray interference is eliminated.
3. The signal to noise ratio is optimized for a given geographical location.

Accuracy. The Loran-C system provides the capability of obtaining submicrosecond synchronization by use of the groundwave. Skywave users can obtain $\pm 10\text{-}50\mu\text{s}$ accuracy. As in any timekeeping system using radio waves, the accuracy depends upon the variations in the system. First, the propagation delay and propagation path variations must be known. Second, the delays through the equipment must be determined and last the operator must have some skill in cycle selection for accurate time transfer. All of these constants can be determined by means of a portable clock.

Advantages and Limitations. Loran-C has a number of tremendous advantages to the timekeeping system user.

1. The transmitters are controlled by redundant cesium standards and are referenced to UTC (USNO). The USNO publishes weekly phase corrections for the chains.
2. Propagation effects of the groundwave signals allow accuracy of time transfer to about ± 0.3 microsecond. Skywave signals can provide $\pm 10\text{-}50 \mu\text{s}$ synchronizations depending upon the number of hops.
3. The time of coincidence, (TOC) explained in later paragraphs, for time coordinated chains is provided in advance by USNO.
4. Equipment costs are reasonable, however, they increase as the user's requirements become more stringent.

In contrast, the limitations are:

1. The time transfer accuracy is limited to the accuracy to which the delays (equipment and propagation) are determined. Terrain effects and mixed sea and land paths limit the obtainable accuracy.
2. Local clock time must be known to better than half the chain repetition period to eliminate Group Repetition Period (GRP) ambiguity (typically ~ 10 milliseconds).
3. Cycle selection is difficult and requires highly skilled operators.
4. Coverage is not global.

Time and Frequency Determination. The Loran-C system does not broadcast a time code signal. Therefore, it is important to know the time-of-coincidence (TOC) of a Loran-C signal relative to a UTC second. Each chain transmits in a particular format, as shown in the example of Figure 4-6. Within the Group Repetition Period, GRP, (a different GRP is assigned to each chain), the master station transmits exactly spaced groups of nine pulses. Each of the slave stations transmits, in turn, eight pulses within the GRP.

There is only one GRP that will provide a TOC every second. The period between a pulse coinciding with one UTC second and another pulse-UTC-second TOC, depends upon the repetition rate of the chain. Each chain is assigned a different repetition period. The available rates are shown in Table 4-3 as well as the period of time between UTC seconds and Loran-C rate coincidence. The TOC varies for the different rates; for example, a repetition period of $59,400 \mu\text{s}$ gives a coincidence interval of 297 seconds, whereas a rate of $79,500 \mu\text{s}$ repeats every 159 seconds. The USNO publishes the periodic coincidence from an arbitrary origin in null ephemeris tables for each calendar year in Series 9 of the Time Service Announcements. The initial date (epoch) for all Loran-C master stations has been arbitrarily set at $00^{\text{h}}00^{\text{m}}00^{\text{s}}$, 1 January 1958. If coincidence measurements are to be made using slave stations, the user must account for the corresponding emission delays.

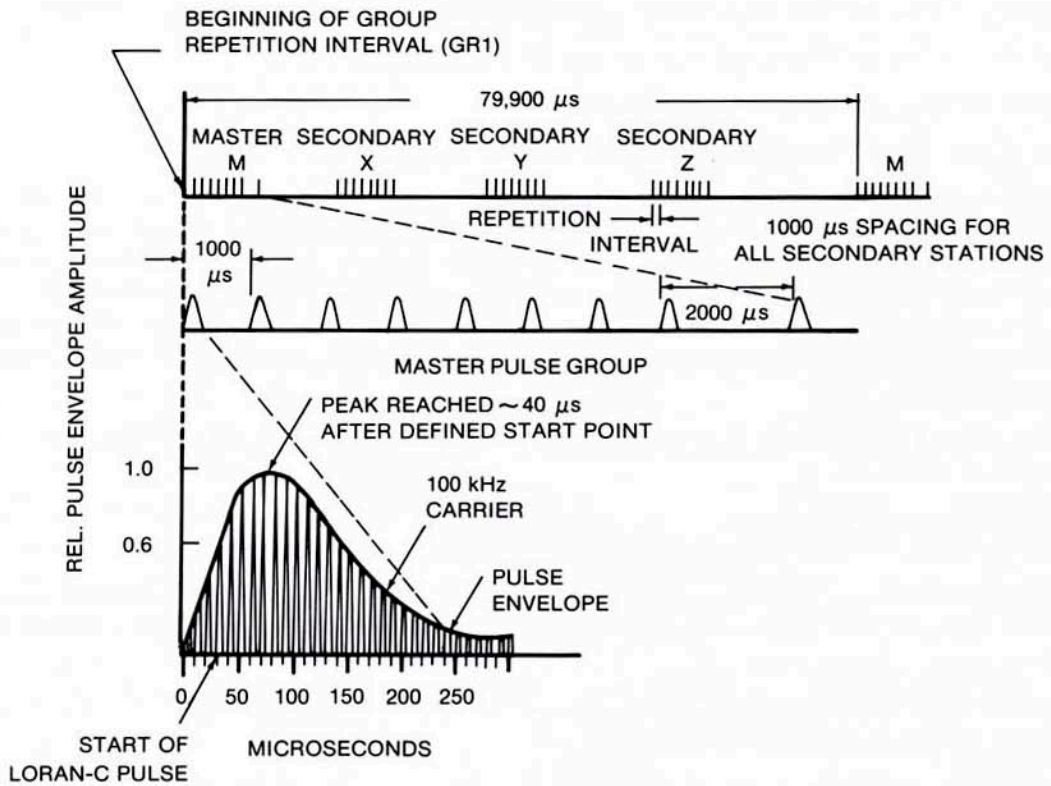

Figure 4-6. Loran-C Pulse Group Format

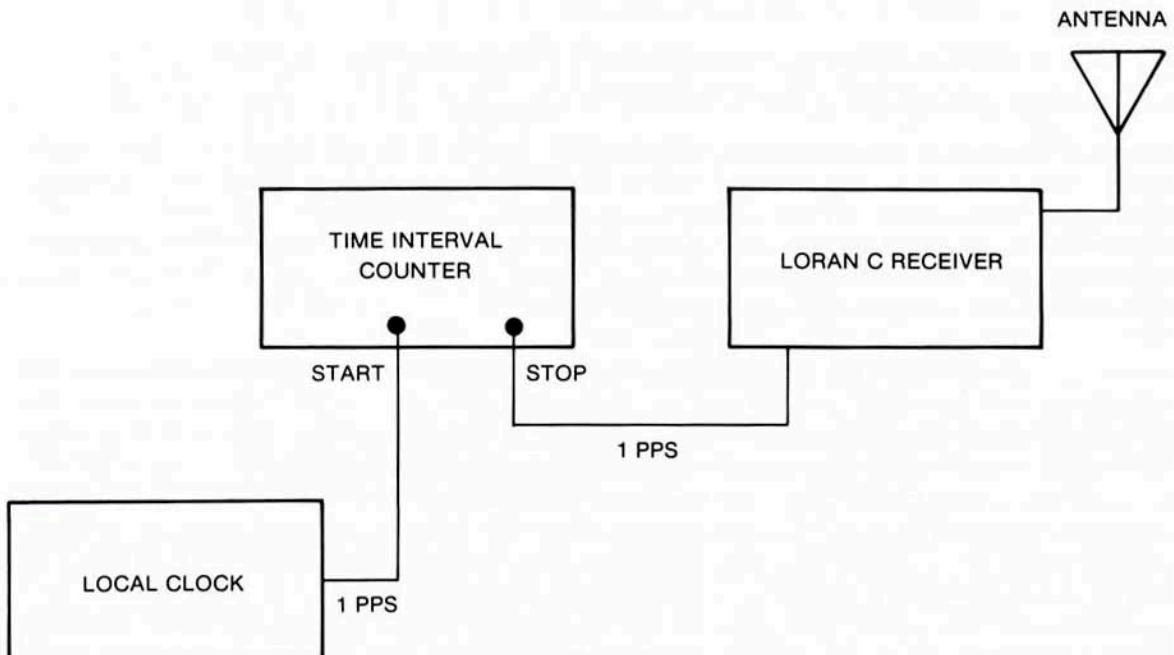

Figure 4-7. Loran-C Timekeeping System

Now that we have an idea of the type of pulses transmitted by the Loran-C network, let us examine how we can make use of this navigation system for time transfer and timekeeping.

Figure 4-7 shows one equipment configuration, out of several, for receiving and utilizing Loran-C transmissions for time transfer. In this particular equipment configuration, the local clock's 1 PPS is used to start a time interval counter and the output of the Loran-C receiver is used to stop the counter. The output of the Loran-C receiver is a 1 PPS phase-locked to the received signal and synchronized to agree with the TOC. Using the count on the Time Interval Counter and published USNO data we can determine the difference between UTC (USNO) and the local clock.

Table 4-3. Loran-C Group Repetition Periods

GROUP REPETITION PERIOD - μs	PERIOD OF TIME BETWEEN UTS* AND LORAN RATE COINCIDENCES (SECONDS)
50,000	1
49,900	499
49,800	249
49,700	497
49,600	31
49,500	99
49,400	247
49,300	493
60,000	3
59,900	599
59,800	299
59,700	597
59,600	149
59,500	119
59,400	297
59,300	593
80,000	2
79,900	799
79,800	399
79,700	797
79,600	199
79,500	159
79,400	397
79,300	793
100,000	1
99,900	999
99,800	499
99,700	997
99,600	249
99,500	199
99,400	497
99,300	993

*UTS = Universal Time Second or UTC Second.

$$\text{UTC (USNO)-UTC (local)} = t_d + t_s - t_m$$

where

t_d = propagation path delay as computed or measured by portable clock trip

t_s = Loran-C transmitter station error as published in USNO Publication Series 4: Daily Phase Values and Time Differences

t_m = measured time difference between received Loran-C pulse and local clock.

Example: At the Hewlett-Packard plant in Santa Clara, California on 10 September 1975, the local clock (a HP 5061A) was compared against the Loran-D (similar format to Loran-C) West Coast station (4930).

$$t_d = 2198.8 \mu\text{s}$$

$$t_s = 11.4 \mu\text{s} \text{ (from Series 4 dated 11 September 1975, copy contained in Appendix E)}$$

$$t_m = 2209.8 \mu\text{s} \text{ (measured with an HP 5345A Electronic Counter)}$$

therefore;

$$\begin{aligned} \text{UTC (USNO)-UTC (HP)} &= t_d + t_s - t_m \\ &= 2198.8 + 11.4 - 2209.8 \end{aligned}$$

$$\text{UTC (USNO)-UTC (HP)} = +0.4 \mu\text{s}$$

which means that the HP local clock was 400 nanoseconds behind UTC (USNO) on 10 September 1975.

TELEVISION SIGNALS

There are several ways television signals can be used to disseminate time and frequency depending on required accuracy, available television accuracy, determination of propagation delays, etc. There are two basic techniques possible with television signals; passive and active. In passive techniques, the TV signal simply acts as a transfer standard for either time or frequency or both. Active techniques involve the unused TV spectrum being used to carry time information. The techniques described in this section pertain to all TV systems, but the discussion centers around the National Television Systems Committee (NTSC) system in use in the U.S.

One passive time transfer technique involves two or more clock locations receiving the same TV transmitter signals. This technique places no restrictions on the individual transmitter. It does require that the clocks to be located within the viewing area of the transmitter. A second passive technique involves two or more clocks receiving the same network broadcast originating from the same studio but relayed to and transmitted by two or more stations in different viewing areas. In this type of technique the system delays must be known as well as the propagation path delays for each individual transmitter and receiver when doing time synchronization. The unknown delays do not affect frequency calibration accuracy.

In one particular experimental time transfer system using passive TV techniques, the USNO obtained the cooperation of a local Washington, D.C. TV station. The color subcarrier frequency, 3.5795 454 . . . MHz, is stabilized with a cesium beam frequency standard and phase shifted so that sync pulses in the vertical interval coincide with 1 PPS signals referenced to the USNO master clock. Specifically, the line-10 pulse marker (odd field) is compared against a one-second pulse of the USNO master clock. A time of coincidence (TOC) between the two pulses occurs every 1001 seconds (16 min 41 sec) due to the repetition rate of the TV frame (33.366 667 ms per frame).

Accuracy. The accuracy obtained using television depends on:

- 1) The particular method being used;
- 2) The degree to which the television signal is related to UTC time scale (in some methods);
- 3) The calculation accuracy for propagation path delays.

It is possible to obtain time accuracy of a few microseconds using a passive line 10 technique from stabilized network programs in the U.S. Using the passive technique previously described for local service areas, time transfer can be made with an accuracy of better than 100 nanoseconds. Using the technique proposed by the USNO, clocks can be synchronized within the local TV service area to within a few nanoseconds of the referenced clock.

Advantages and Limitations. Table 4-4 lists the advantages and limitations of the various TV time and frequency transfer techniques.

Table 4-4. Advantages and Limitations of TV Time and Frequency Transfer

Television Technique	Advantages	Limitations
Transfer standard (differential) using a TV sync pulse received in a TV transmitter local service area.	<ol style="list-style-type: none"> 1. Precise clock comparisons can be made to better than 100 ns. 2. Comparisons can be made at any time during transmission without modification or influence on network programming. 3. Method is independent of microwave network routing. 4. Comparison equipment at a receiving station is relatively inexpensive. 5. Measurement methods are simple. 6. Simultaneous clock measurements can be made at an unlimited number of stations within a local service area. 	<ol style="list-style-type: none"> 1. Clock readings must be taken simultaneously by timing centers requiring synchronization. 2. Data must be exchanged between participating stations after the fact of measurement. 3. Technique gives only comparative clock differences. Calibrated path delays between stations is required for absolute time comparison. 4. Coverage limited to line of sight VHF or UHF signals which may be subject to multipath interference within a local TV service area.
Transfer standard (differential) using received TV line-10 throughout continental U.S.	<ol style="list-style-type: none"> 1. Precise clock comparisons can be made to about several microseconds nearly anywhere throughout continental U.S. 2. Three television networks with atomic clock references (Rb) provide redundancy and enable cross synchronization; system has no effect on network programming. 3. One-a-day measurements are adequate for precise frequency standards. 4. Users can compare TV line-10 measurements with published NBS and USNO values and relate time scales if propagation path is calibrated. 5. Modular frame intervals can permit advance predicted TV delays. 	<ol style="list-style-type: none"> 1. Microwave paths can be interrupted or networks rerouted without notice. 2. Clock readings must be made simultaneously by all stations requiring synchronization. 3. Measurements require simultaneous viewing of "live" broadcasts originating from New York City studios for near-continental coverage; present network distribution system uses a delay tie-in with West Coast transmission lines which limits coverage of West Coast area; also there is limited availability of simultaneous viewing of nationwide network programs. 4. System will not work with tape delays. 5. NBS and USNO measurements are not made on weekends and reference data at these times are unavailable. 6. Line-10 TV system ambiguity is ~33 ms. 7. Propagation anomalies may limit system's usefulness in some areas of the continental U.S.
Real time transfer from time-scale-related transmissions (line-10 in local TV service area).	<ol style="list-style-type: none"> 1. System can set or synchronize clocks within the local TV service area to a few nanoseconds of a reference clock. 2. The stabilized modular frame intervals permit prediction of TOC between 1 pps of an atomic time scale and emitted line-10 odd pulses, months in advance. This allows construction of TOC charts and independent clock synchronizations. 3. System will operate with existing line-10 TV receivers. 4. Operation is without interference or effect on regular programming. 5. Measurement methods are simple. 	<ol style="list-style-type: none"> 1. Requires installation of atomic cesium clock and phase shifting synthesizer at local TV transmitter. 2. Absolute clock calibrations require knowledge of delay between the transmitter atomic standard and local standard at TV receiving site. 3. Clock time must be known to half the system ambiguity or ~16 ms. 4. Coverage limited to line of sight VHF or UHF signals which may be subject to multipath interference within a local TV service area.

Time and Frequency Determination. The equipment setup for the passive line-10 techniques is shown in Figure 4-8. For the two methods described previously using line-10, differences occur in the techniques involved rather than the equipment required.

As shown in Figure 4-8, the equipment required is:

- 1) A TV receiver;
- 2) A line-10 pulse generator;
- 3) The local standard;
- 4) A time interval counter;
- 5) An optional digital recorder (printer).

The basic measurement between two or more locations involves each observer starting a time interval counter with a 1 PPS tick at an agreed upon time. The counter is then stopped with the next TV line-10 sync pulse. The observers at each location must communicate with each other and calculate the difference in their respective time interval readings. In the case of the network system, reference time interval readings are published by NBS and USNO at specific times of day. The NBS publications include data on the West Coast networks as supplied by the Hewlett-Packard Company. The difference in the readings is the sum of the clock errors and the difference in total path delays.

If time is to be transferred from one location to another via a single TV transmitter, the distance from the TV transmitter location to each of the receivers can be computed. In addition the propagation delay calculated as described in Appendix A for millisecond accuracies or for microsecond accuracy a portable clock type would be required.

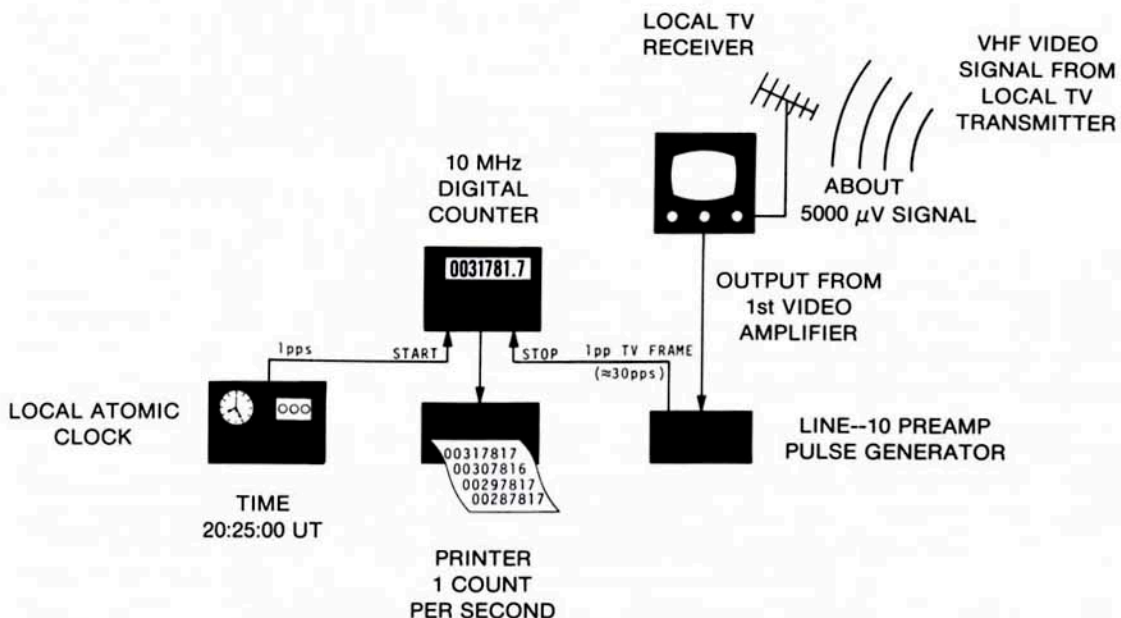

Figure 4-8. Typical Line-10 TV Receiver Equipment Configuration

Example:

It is mutually agreed that two stations, with identical equipment, equidistant from Channel 5 located nearby will compare their clocks each day at 12^h10^m00^s each day. In the month of August they obtain the following results:

TIME INTERVAL MEASUREMENT (μsec)			
Date	Receiver 1	Receiver 2	Difference
9	2973.7	2637.6	336.1
10	2437.5	2100.3	337.2
11	2556.5	2218.1	338.4
12	2097.3	1757.8	339.5
13	1976.5	1635.8	340.7

The data gives a $\Delta t = 1.1\mu\text{sec}/\text{day}$ with no apparent aging or drift effects (measurement over a longer time would provide a better comparison of aging or frequency drift between the two clocks). The frequency offset for the two clocks can be computed by:

$$\frac{\Delta f}{f} = \frac{\Delta t}{t} = \frac{1.1\mu\text{sec}}{24 \text{ hours}} = 1.27 \times 10^{-11} \text{ frequency offset (difference) between the two clocks.}$$

It should be noted that for this particular example, the equipment was the same in both receivers and hence the difference in system delays was negligible (this should be verified in an actual situation). Secondly, the receivers were equidistant from the transmitter and therefore the propagation path delay difference was negligible.

Of course the system and path delays are only important for time transfer (such as the USNO system) and not frequency comparison since frequency comparison is dependent only upon the relative rate difference of the two clocks. The initialization of the two clocks can be accomplished via a portable clock or if a portable clock is not available, the clock which is to be designated the remote site could be transported to the master clock location, synchronized, and then returned to its own location. Unfortunately, for this particular time and frequency transfer technique, the two clocks must be within 33 ms of each other to remove ambiguity of framing pulses. The use of a flying clock could also provide a means of calibrating the propagation path delays. In the table of measurements, the actual time interval measurement changed from day-to-day although the difference was fairly constant. The randomness is due to the fact that the TV frequency differs from UTC by about -300×10^{-10} and the frame rate is not coincident with 1 PPS. The stability of the TV transmitter is unimportant in this case. What is important is that the two clocks measure time from the same pulse.

NETWORK TV USAGE—The equipment setup is the same for this technique as shown in Figure 4-8. All three of the major U.S.A. networks (ABC, NBC, CBS) stabilize their color subcarrier (3.579 . . . MHz) using Rubidium frequency standards. The frequency, however, is offset by about -300×10^{-10} due to the fact that the Rubidium standards were installed during the time when the UTC was offset -300×10^{-10} relative to atomic time, AT (the official offset is currently zero).

All three of the networks are monitored in frequency relative to the NBS and USNO and data are published to indicate the performance of the network frequencies. The fact that the networks' frequencies are available to a large number of users and the receiving equipment is relatively inexpensive makes it very attractive as a time and frequency transfer medium. Information regarding the use of a low cost comparator for direct frequency comparison against the TV color subcarrier frequency (3.579 . . . MHz) is available from NBS, Time and Frequency Services Section, Boulder, Colorado, 80302.

There are three major problems in using network TV signals in the U.S. First, the propagation path can change due to changes in the routing of the TV signal over microwave networks, etc.

Second, the show being used must be a broadcast originating from the network studio. This separates the West Coast from the East Coast and Midwest portions of the U.S. due to the fact that almost all programs from the East Coast are retransmitted on the West Coast at a later time. Data on the West Coast transmissions are now being published by NBS. Third, to use the networks as a frequency standard requires that the user take his measurements and then wait for the NBS and USNO to publish data on the network performance or call either agency before he can verify his own performance. This delay creates a lag in being able to correct his own frequency. However, with reasonable reliability one can extrapolate the NBS and USNO frequency data since the network Rubidium clocks are seldom changed.

TIME AND FREQUENCY TRANSFER USING NETWORK TV—The broadcasts over network TV can be used to transfer time and frequency from one location to another. The technique is the same as if the same transmitter were used except that now the same program source is used, i.e., the network studio. However, the delay from the studio to each location must be determined for time transfer and the same network program must be used. The delay can be calibrated using a portable clock.

EXPERIMENTAL TV TECHNIQUES—The cesium stabilized line-10 system developed by the USNO is currently an experimental system. The potential for this system to become operational appears to be in the distant future due to the costs involved.

PORTABLE CLOCKS

The most accurate and reliable method for transferring time from one location to another involves physically transporting a clock from one site to the other. This technique is by no means a new one. International comparisons were made by carrying piezo resonators to seven laboratories in Italy, France, England and the United States in 1923. Primary frequency standards were shown to be in agreement to within 1 part in 10^3 . Several portable clock trips were conducted between 1923 and 1964 using quartz oscillators and early cesium standards. The accuracies obtained during these trips varied between 3 parts in 10^5 to several parts in 10^{10} .

In 1964 Hewlett-Packard initiated a series of experimental flying clock trips. The last of the series was conducted in 1967. In the last trip, which took 41 days, 53 locations in 18 countries were visited. The clocks were transported over 100,000 km with time correlations accurate to about $0.1\mu\text{s}$. The time closure between the reference clock and the two portable clocks was $3.5\mu\text{s}$ corresponding to frequency differences of 5 and 10 parts in 10^{13} between the portable standards and the reference.

Since the first availability of the HP 5060A and its successor, the HP 5061A Cesium Beam Frequency Standards, numerous government and commercial agencies and organizations have conducted portable clock time transfers with excellent success.

Accuracy. As mentioned before, the portable clock technique for transferring time is the most accurate of the commonly used practices. Time transfer can be accomplished within 100 ns and frequency can be transferred with an accuracy of 1 part in 10^{-12} for one trip and parts in 10^{-14} for multiple trips using cesium clocks. Other clocks such as rubidium and quartz can be used but with lesser accuracy.

Advantages and Limitations. The advantages of the portable clock technique include:

1. Microsecond time synchronization of remote clocks can be obtained without a dependent radio link and the corresponding delays and propagation errors.
2. Manpower needs are minimal and equipment normally can be found in a standards laboratory.

3. The portable clocks are relatively lightweight, rugged and can operate from either internal standby batteries or external AC/DC sources.
4. The portable clocks are easily transported by commercial airlines and automobiles.
5. Newer portable cesium standards are relatively insensitive to shock and vibration, smaller in size and lighter in weight.

Limitations are:

1. The most accurate portable clocks are expensive, and the technique requires physical transportation of the clocks which in itself can be expensive. The accuracy obtainable is directly related to the cost of the clock.
2. The clocks are usually handcarried and, although experience has indicated high reliability, there is the possibility of the clocks stopping or changing rate enroute due to power outages, excessive vibration, or environmental changes of temperature, humidity or air pressure.
3. It is difficult or impossible to make side-by-side comparisons at some locations due to inaccessibility such as certain islands, mountain stations, etc. In these cases, an aircraft fly-over technique can be used, but the cost of the operation increases significantly. The aircraft fly-over technique is described in detail in NBS Monograph 140.

Time and Frequency Transfer. Accomplishing a time and frequency transfer using a portable clock is a relatively simple task. Figure 4-9 shows a typical equipment configuration at the master clock location. If we wish to initially set a remote clock, there are basically two methods which can be used depending upon the initial accuracy desired. The most accurate technique requires that the transfer clock (portable clock) be initially compared and set both in frequency and time as closely as possible with the master clock.

The procedure is as follows:

Using a linear phase-comparator (such as K05-5060A or K19-5061A) and a strip chart recorder, compare the relative phase drift of the 5 MHz signal from the two standards long enough to achieve the level of measurement accuracy desired.

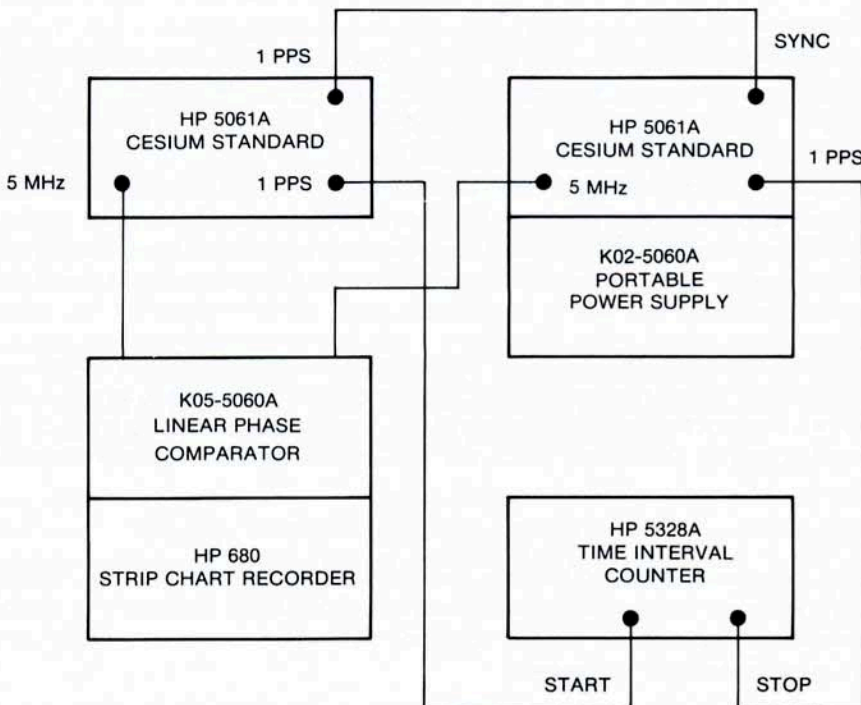

Figure 4-9. Typical Portable Clock Equipment Setup (at Master Station)

Example:

The accuracy desired is that obtainable with the High Performance Cesium Beam Frequency Standards, HP 5061A with Option 004. Assume that all three standards (master, portable, and remote) are High Performance Units. The settability of the HP 5061A Option 004 is 1×10^{-13} (using the HP 10638A Degausser).

At 5 MHz each minor division on the HP 680A Strip Chart Recorder corresponds to 4 ns of phase. If we watch the phase chart and detect 4ns phase change in 67 minutes (4000 secs) then the frequency offset is

$$\left| \frac{\Delta f}{f} \right| = \left| \frac{\Delta t}{t} \right| = \frac{4 \times 10^{-9}}{4 \times 10^3} = 1 \times 10^{-12}$$

This measured frequency offset tells us that we have to correct the frequency of the portable clock by 10×10^{-13} . The direction of the phase change will tell us which direction it must be corrected. By adjusting the portable clock oscillators fine frequency control knob from 250 to 200 in OPEN LOOP, we can note the direction of the phase change. The portable clock frequency is now low and will lose time. Reset to 250 and close the loop.

NOTE: Also make a notation as to the inputs to the K05-5060A. In future setups noting the connections to the inputs will determine which unit is fast or slow relative to other.

Using the C-field knob we can adjust the portable clock frequency by 10×10^{-13} . Each minor division of the C-field knob corresponds to 5×10^{-14} (increasing numbers will increase frequency), therefore the number of minor divisions is

$$\frac{10 \times 10^{-13}}{5 \times 10^{-14}} = 20$$

Once again, measure the frequency difference using the linear phase comparator. If the adjustment has been properly made, the time required to measure a 4ns phase change should be greater than 11.1 hours (40,000 s), assuming the adjustment is better than the settability spec, 1×10^{-13} .

Now that the frequency has been set, we can set the time in the portable clock. To do this first requires that the clock display be adjusted to correspond within 1 sec of the master clock. This is easily accomplished using the pushbuttons on the clock. Once the time is set to the nearest second, a cable is connected from the 1 PPS output of the master clock to the SYNC input of the portable clock and the SYNC button is pressed. The portable clock is now synchronized to within $10 \pm 1 \mu\text{s}$ delay of the master clock. Now connect the master clock 1 PPS to the START input of a time interval counter and the portable clock 1 PPS to the STOP input of the counter. Measure the time interval between the two pulses. The two pulses can be manually adjusted to within $\pm 50\text{ns}$ of each other using the thumbwheel TIME DELAY switches and the 0-1 μsec TIME DELAY control.

The time difference, frequency offset, and time of measurement should be noted.

Move the portable clock to the remote site and perform steps 1 through 6 again, only this time the portable clock is the master and the remote clock is adjusted relative to the portable clock. Return the portable clock to the master clock site and again measure the time interval between the two clocks.

Example:

1. In transferring time from one location to another we use a portable clock. In setting the portable clock we note a time difference (measured) of 45 ns (behind the master clock) at the measurement time of 12^h15^m00^s 12 April 1974. The frequency offset at this time was 1×10^{-13} as we previously adjusted.
2. At the remote site we set the remote clock and measured a time difference of 50 ns with the portable clock behind the remote clock. We adjusted the remote clock to within

1×10^{-13} of the portable clocks frequency. The time of measurement for the time interval reading was 12^h15^m00^s 18 April 1974.

3. Returning the portable clock to the master clock site and making another time interval measurement (closure of the loop) we find a time difference of 776nsec ahead of the master clock. We attempted to make the two portions of the trip as equal as possible to simplify the error apportionment, therefore, when we returned the measurement was made at 12^h15^m00^s 24 April 1974.

<u>Date</u>	<u>Measurement Number</u>	
12 April 74	1	Master-portable = 45ns
18 April 74	2	Remote-portable = 50ns
24 April 74	3	Master-portable = -776ns

Subtracting reading 1 from reading 3 we get

$$\begin{aligned}\Delta t_{\text{total}} &= \Delta t_3 - \Delta t_1 \\ \Delta t_{\text{total}} &= -776\text{ns} - (45)\text{ns} = -821\text{ns}\end{aligned}$$

Therefore on 18 April 1974, the remote clock was set relative to the master clock as calculated below:

$$\text{Master-portable} = 45 + \left(-\frac{821}{2}\right) = -365.5\text{ns}$$

and subtracting reading 2

$$\begin{array}{rcl} \text{master-portable} & = & -365.5\text{ns} \\ -(\text{remote-portable}) & = & -50.\text{ ns} \\ \hline \text{master-remote} & = & -415.5\text{ns} \end{array}$$

We might note here that we are unconcerned about readjusting the frequency offsets as measured. The only purpose in adjusting the frequencies for an initial clock setting is to try to bring the clocks closer together in frequency so that they might keep close relative time for a longer period. The frequency adjustment or measurement could have been eliminated if we were unconcerned about their relative frequencies. The relative frequencies might not be important to us at this time if we know the instruments are operating properly and within the manufacturer's specifications. The accuracy of the HP 5061A Option 004 High Performance Cesium Standard is $\pm 7 \times 10^{-12}$. Therefore, the maximum two units could be apart is 1.4×10^{-11} . If this frequency offset is within the timekeeping system requirements there is little gained in making the frequency adjustment in an initial time synchronization. However, the frequency measurement might still be made just to assure us that the instruments are operating properly.

The maintenance of a timekeeping system using portable clocks is not difficult. Periodic trips are made back to the remote sites and time measurements and adjustments made. For example, let us continue the previous example:

<u>Date</u>	<u>Measurement Number</u>	<u>Measurement</u>	<u>Remarks</u>
12 Oct 74	1	Master-portable = 45ns	
18 Oct 74	2	Remote-portable = 8471.5ns	Before reset
18 Oct 74	3	Remote-portable = 45ns	After Resynchronization
24 Oct 74	4	Master-portable = +445ns	

$$\begin{aligned}\Delta t_{\text{total}} &= \Delta t_3 - \Delta t_1 \\ &= 455\text{ns} - 45\text{ns} = 410\text{ns}\end{aligned}$$

Therefore, on 18 October 1974

$$\begin{aligned} \text{master-portable (adjusted)} &= 45 + \frac{410}{2} = 250\text{ns} \\ \text{master-portable} &= 250 \text{ ns} \\ \text{-(remote-portable)} &= -8471.5\text{ns} \\ \hline \text{master-remote} &= -8221.5\text{ns (on 18 October 1974)} \end{aligned}$$

which indicates the remote clock is fast relative to the master.

From this information we can now calculate the average frequency offset between the master and remote clocks during the six month period.

$$\frac{\Delta f}{f} = - \frac{\Delta t}{t}$$

where $\Delta t = (\text{master-remote})_{18 \text{ Oct}} - (\text{master-remote})_{18 \text{ Apr}}$
 $= -8221.5\text{ns} - (-415.5\text{ns}) = -7806 \text{ ns}$
and $t = 183 \text{ days}$

$$\frac{\Delta f}{f} = - \frac{\Delta t}{t} = \frac{7806 \times 10^{-9} \text{ second}}{183 \text{ days} \times 86400 \frac{\text{sec}}{\text{day}}} = +4.94 \times 10^{-13}$$

Thus, the remote clock can be either adjusted or the frequency offset just noted, depending on whether the performance is within the established system tolerances.

The calculation of the resynchronized time setting error is:

$$\begin{aligned} \text{master-portable} &= 250\text{ns} \\ \text{-(remote-portable)} &= -45\text{ns} \\ \hline \text{master-remote} &= 205\text{ns} \end{aligned}$$

If more than one remote clock is involved in the system and compared on the same portable clock trip, the closure error can be allocated to each clock listed in proportion to the time of measurement to total trip time.

OTHER TIME AND FREQUENCY TRANSFER METHODS

In this section we have examined several of the more popular techniques of time and frequency transfer. There are several other techniques using a variety of radio waves. The techniques are basically the same as those already discussed. Each technique requires a good receiver to receive a stable signal and appropriate processing equipment as required. NBS Monograph 140 describes several techniques using satellites (including Transit and Timation) microwave links, Omega, very long baseline interferometry (VLBI), pulsars, and the ac power line.



APPENDIX A

RADIO PROPAGATION PATH DELAYS

To accomplish time transfer via radio waves, the radio propagation path delay has to be determined as accurately as possible. If microsecond or sub-microsecond accuracies are required then the path delay must be determined by a portable clock trip. If only millisecond accuracies are required, then calculations can be accomplished of the Great Circle distance and the associated propagation path delay.

COMPUTATION OF THE GREAT CIRCLE DISTANCE

With the advent of hand-held scientific calculators such as the HP-21 or HP-25 calculators, the Great Circle distance can be quickly calculated provided the latitude and longitude of both the transmitter and receiver are known.

$$D = \cos^{-1} [\sin(\text{lat}_A) * \sin(\text{lat}_B) + \cos(\text{lat}_A) * \cos(\text{lat}_B) * \cos(\text{lng}_B \pm \text{lng}_A)] * 60$$

Where D = Great Circle distance in nautical miles and sign between lng is + if A and B are not on same side of Equator.

Example:

What is the Great Circle distance between WWV (Ft. Collins, Colorado) and Palo Alto, California.

WWV	Latitude = Lat _A = 40°41' = 40.68333 . . . °
	Longitude = Lng _A = 105°02' = 105.0333 . . . °
Palo Alto	Latitude = Lat _B = 37°23' = 37.38333 . . . °
	Longitude = Lng _B = 122°09' = 122.15°
Lng _B -Lng _A	= 122°09' - 105°02' = 17.1166667°

$$D = \cos^{-1} [\sin(\text{lat}_A) * \sin(\text{lat}_B) + \cos(\text{lat}_A) * \cos(\text{lat}_B) * \cos(\text{lng}_B - \text{lng}_A)] * 60$$

using the HP-21

$$D = 820.4908374 \text{ nautical miles} \\ = 1519.549 \text{ km}$$

TRANSMISSION MODES

The ground-wave propagation path (most LF transmissions under 1000 km and HF transmissions under 100 km) closely follows the Great Circle route between the transmitter and receiver. However, HF transmissions over a distance of more than about 160 kilometers follow sky-wave paths. VLF transmissions from distances over 1000 km are almost pure skywaves; but for shorter ranges the received signals are a varying mixture of several paths. VLF skywaves are reflected from the D layer at heights of 70 km daytime and 90 km at night. LF skywaves are reflected from the E layer.

HF SIGNAL MULTIPLE HOPS

The maximum distance that can be spanned by a single hop (i.e. one reflection from the ionosphere) via the F2 layer is about 4000 km (Figure A-1). Therefore, the fewest number of hops between transmitter and receiver is the next integer greater than the Great Circle distance (in kilometers) divided by 4000. Transmission modes with one or two more hops than the minimum number of hops occur frequently (Figure A-3), but modes of higher order are greatly attenuated during transmission and are of little concern.

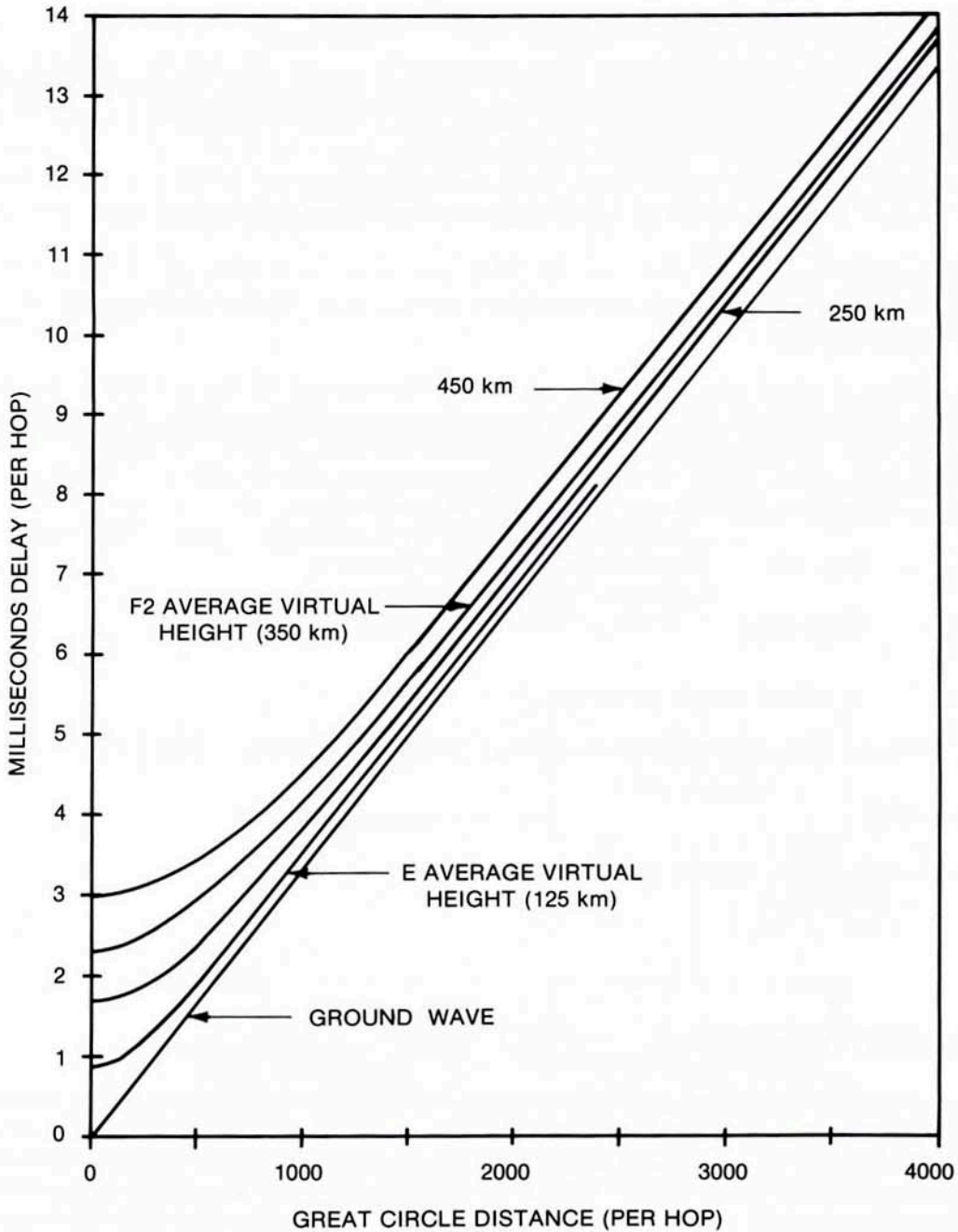

Figure A-1. Transmission Delay Graph

Example 1: Find the minimum number of hops for a distance of 3923 km.

Solution: A one-hop F2 mode is possible ($3923 \div 4000 < 1$).

Example 2: What modes are likely to be received at a distance of 7687 km?

Solution: Two-hop, three-hop, and four-hop F2 modes can be expected ($7687 \div 4000 > 1$, but < 2).

Useful transmissions via the E layer (daytime only) are usually limited to one-hop modes up to a distance of about 2400 km.

Remember that some locations may receive transmissions from both the E and F2 layers and that transmissions may be reflected occasionally from layers other than E and F2.

The following approach should improve your estimate of propagation delay:

Determine which modes are possible at your location.

Tune to the highest frequency which provides consistent reception to reduce interference from high-order modes.

If several modes are being received (indicated by multiple tick reception or tick jitter between fairly constant positions), select the tick with earliest arrival time for measurements.

After plotting time measurements for several weeks, either disregard measurements which are conspicuously out of place, or correct measurement to the more likely mode if the plot is mistimed by the difference in time between possible modes.

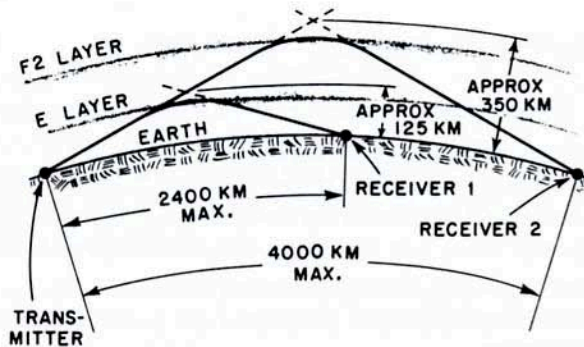

Figure A-2. Single-hop Sky-wave Paths

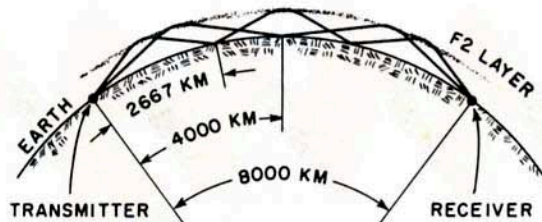

Figure A-3. Multiple-hop Transmission Path

HEIGHT OF IONOSPHERE

Long-distance HF transmissions are usually reflected from the F2 layer, which varies in height from about 250 to 450 km. Experience has shown that the virtual height of the F2 layer averages about 350 km (Figure A-2). Unless special studies permit determination of layer height, 350 km can be used for delay estimation.

The E layer is dense enough to reflect HF transmissions only during the daytime at a virtual height of about 125 km (Figure A-2). One hop E modes may provide very steady daytime reception at distances up to about 2400 km.

DELAY DETERMINATION

Once the transmitter-to-receiver distance, possible transmission modes, and layer heights have been determined, transmission delay can be found graphically from Figure A-1. The shaded area along the F2 curve shows the possible extremes of height variation.

As shown in the following examples, the delay for a one-hop mode can be read directly from the transmission delay graph for a given distance and layer height.

Example 1: Find the one-hop delay for a distance of 3923 km.

Solution: Expected F2 delay is about 13.60 ms. No one-hop E mode is likely since the distance is greater than the usual limit of 2400 km for the one-hop E mode.

Example 2: Find the one-hop delay for a distance of 2200 km.

Solution: Expected F2 delay is about 7.90 ms; expected E delay is about 7.50 ms.

For a multi-hop mode:

- Determine the distance covered by each hop.
- Find the delay for a single hop.
- Multiply the single-hop delay by the number of hops to determine the total delay.

Example 3: Find the two-hop delay for a distance of 3923 km.

Solution: Each 1962 km hop contributes a delay of about 7.15 ms, the total delay is 7.15×2 or 14.30 ms. Note that the two-hop delay for a 3923 km distance is 0.7 ms greater than the one-hop delay for the same distance determined in Example 1 above.

Example 4: Find the three-hop delay for a distance of 7687 km.

Solution: The delay contributed by each 2562 km hop is about 9.05 ms; the total delay is 9.05×3 or 27.15 ms.

Example 5: Find the four-hop delay for a distance of 7687 km.

Solution: The delay contributed by each 1922-km hop is about 6.95 ms; the total delay is 6.95×4 or 27.80 ms. Note that the four-hop delay for 7687-km distance is 0.65 ms greater than the three-hop delay for the same distance determined in example above.

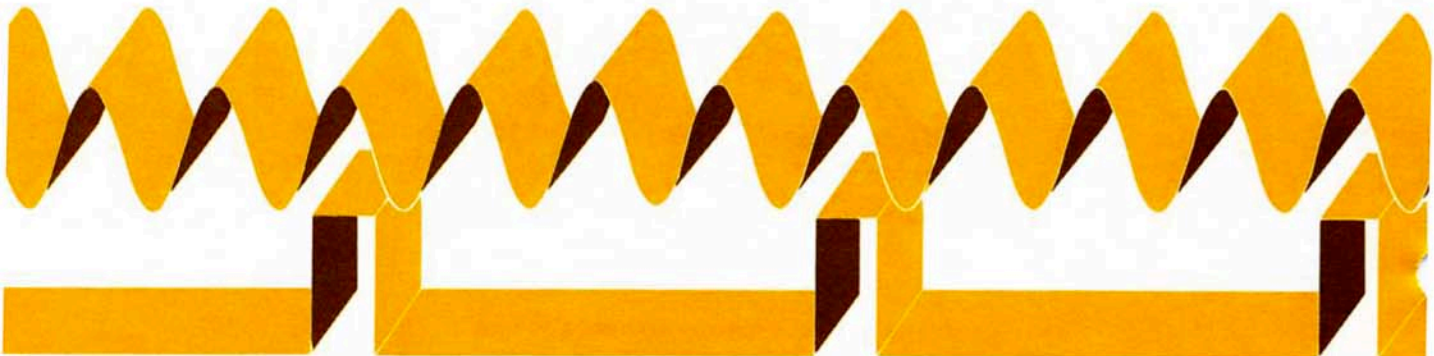

APPENDIX B

DERIVATION OF TIME ERROR EQUATION

As mentioned in Section II, the frequency at any time t can be expressed (with the rate of frequency shift approximately by a straight line):

$$f_t = f_o + af_r t \quad (\text{Eq. 1})$$

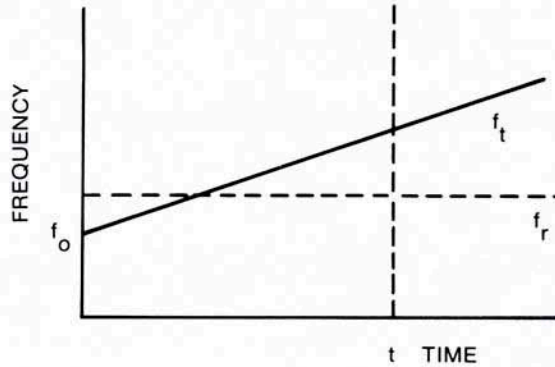

Figure B-1. Oscillator Frequency Vs. Time

where: f_t = frequency at time t
 f_o = initial frequency at time $t = 0$
 f_r = reference frequency (standard)
 a = aging rate or drift

Aging rate or drift rate is the fractional rate of change of frequency per unit of time. The aging rate or drift is generally stated in terms of fractional frequency deviation per unit of time. Fractional frequency deviation is defined as:

$$\frac{\Delta f}{f_r} = \frac{f_2 - f_1}{f_r}$$

$$f_1 = f_t \text{ at } t_1$$

$$f_2 = f_t \text{ at } t_2$$

For quartz oscillators the aging rate is normally stated in terms of daily fractional frequency deviation; e.g., $\pm 5 \times 10^{-10}/\text{day}$. Whereas the drift (rather than aging rate) of rubidium standards is specified on a per month basis; e.g., $\pm 1 \times 10^{-11}/\text{month}$.

Now, since f_t differs by a small amount from f_r , the clock, based upon this oscillator, will gain or lose time because each oscillator cycle is a little short or long. In the case illustrated by the sketch, f_t is increasing with respect to f_r ; the time of each cycle the oscillator makes is short by an amount L .

$$L = \frac{1}{f_r} - \frac{1}{f_t}$$

In an arbitrarily short time Δt , there are $f_t \Delta t$ cycles. The incremental time error ΔE can be written:

$$\begin{aligned}\Delta E &= L f_t \Delta t \\ &= \left(\frac{1}{f_r} - \frac{1}{f_t} \right) f_t \Delta t\end{aligned}$$

Taken to the limit,

$$dE = \left(\frac{1}{f_r} - \frac{1}{f_t} \right) f_t dt = \left(\frac{f_t}{f_r} - 1 \right) dt$$

To obtain E,

$$E = \int \frac{f_t}{f_r} dt - \int dt$$

But:

$$f_t = f_o + a f_r t$$

Therefore:

$$E = \int \frac{f_o + a f_r t}{f_r} dt - \int dt = \int \frac{f_o}{f_r} dt + \int a t dt - \int dt$$

$$E = \frac{f_o}{f_r} t + \frac{a t^2}{2} - t + c$$

At $t = 0$, $c = E_o$, the initial error. Therefore the total time error is:

$$E = E_o + \left(\frac{f_o}{f_r} - 1 \right) t + \frac{a t^2}{2} \quad (\text{Eq. 2})$$



APPENDIX C

RECALIBRATION CHARTS FOR QUARTZ OSCILLATORS AND RUBIDIUM STANDARDS

Figures C-1 and C-2 are useful for estimating the length in days of the recalibration cycle for an oscillator with known drift rate to keep the time system based on it within prescribed error limits. A recalibration cycle is the time, in days, that can be allowed to pass between calibration adjustments. A shorter cycle (more frequent adjustments) is needed to keep a system accurate to $\pm 100\mu\text{s}$ (total time excursion, $2E_o = 200\mu\text{s}$) than to, say, 1 ms.

To use the charts, select the slant line marked for the aging or drift rate (in parts per day for quartz oscillators and parts per month for rubidium standards) of the oscillator. Note the intersection of this line with the horizontal line corresponding to the permitted error excursion. This intersection, referred down to the horizontal axis, gives the recalibration cycle.

Example:

A time system is to be maintained to within 10 ms based on a quartz oscillator with a positive aging rate, $a = 5 \times 10^{-10}/\text{day}$. To use the chart to estimate the length of the recalibration cycle, locate the slant line marked “ $5 \times 10^{-10}/\text{day}$ ” and note its intersection with the horizontal line corresponding to a total time excursion of 20 ms (± 10 ms). The answer read from the chart is 60 days (computed answer using the formulae in Section II is 60.8 days). Note that to use Figure C-1, aging rate must be expressed in parts/day and permitted time excursion, in milliseconds.

Example:

A rubidium based time system is to be maintained within $10\mu\text{s}$. The drift rate is a positive $1 \times 10^{-11}/\text{month}$. Looking at the appropriate slant line corresponding to the drift rate yields a recalibration time of 101 days for $2E_o = 20\mu\text{s}$.

These charts provide graphical solutions to the equation:

$$T_2 = 4 \sqrt{\frac{E_o}{a}}$$

where:

- T_2 = number of days between oscillator recalibrations
- E_o = error limit, ms or μs
- a = drift rate, parts/day or parts/month

To obtain a straight-line plot, this equation is placed in slope-intercept form ($y = mx + b$):

$$T_2 = 4 \sqrt{\frac{E_o}{a}}$$

$$T_2^2 = 16 \frac{E_o}{a} = \frac{8}{a} (2E_o)$$

$$2E_o = \frac{a}{8} T_2^2$$

$$\log (2E_o) = 2 \log T_2 + \log \frac{a}{8}$$

The log-log plot is a line with slope = 2 and intercept = $\log \frac{a}{8}$. For selected values of “a”, Figure C-1 and C-2 show the regions of interest.

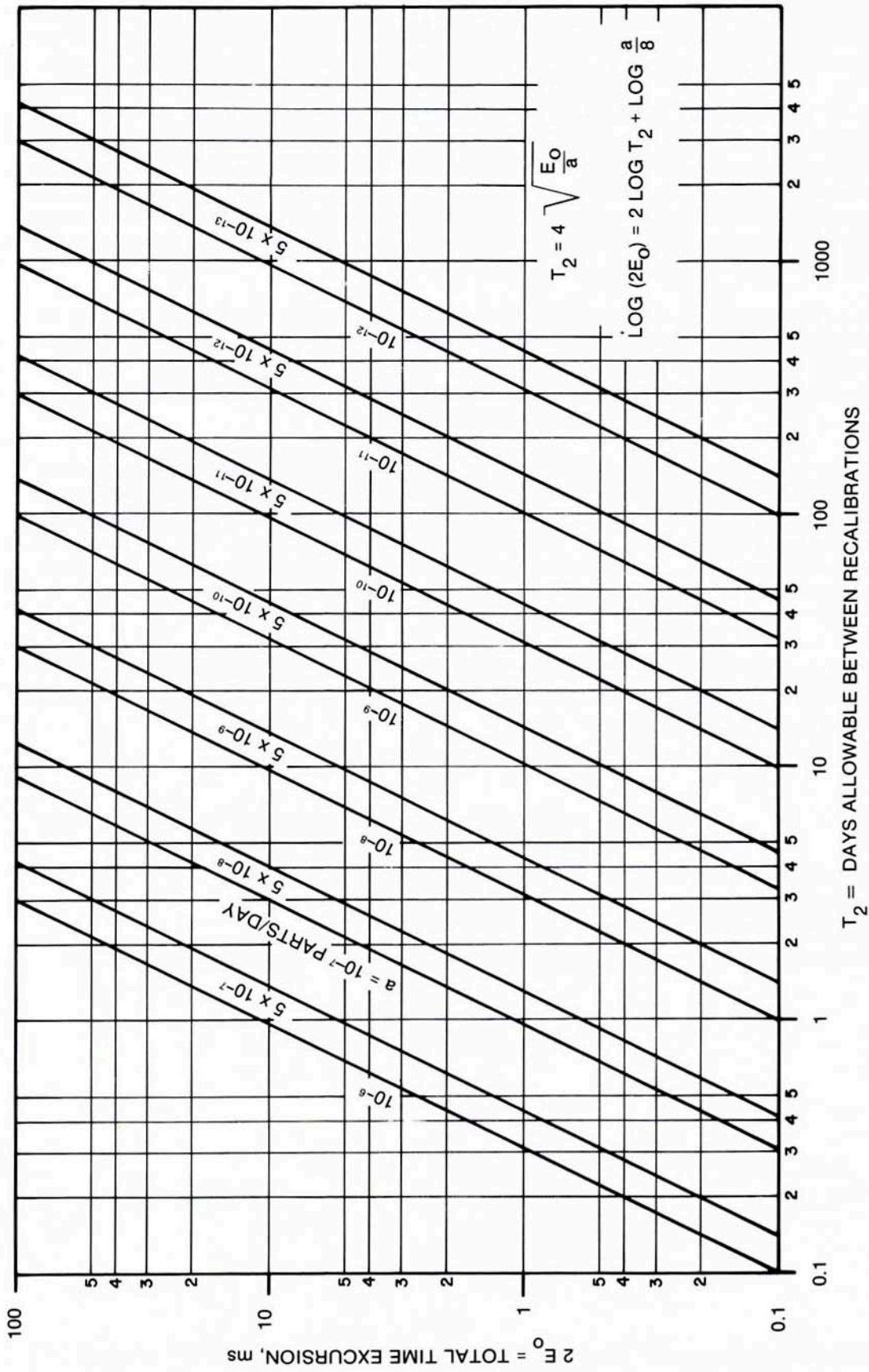

Figure C-1. Recalibration Chart for Quartz Oscillators

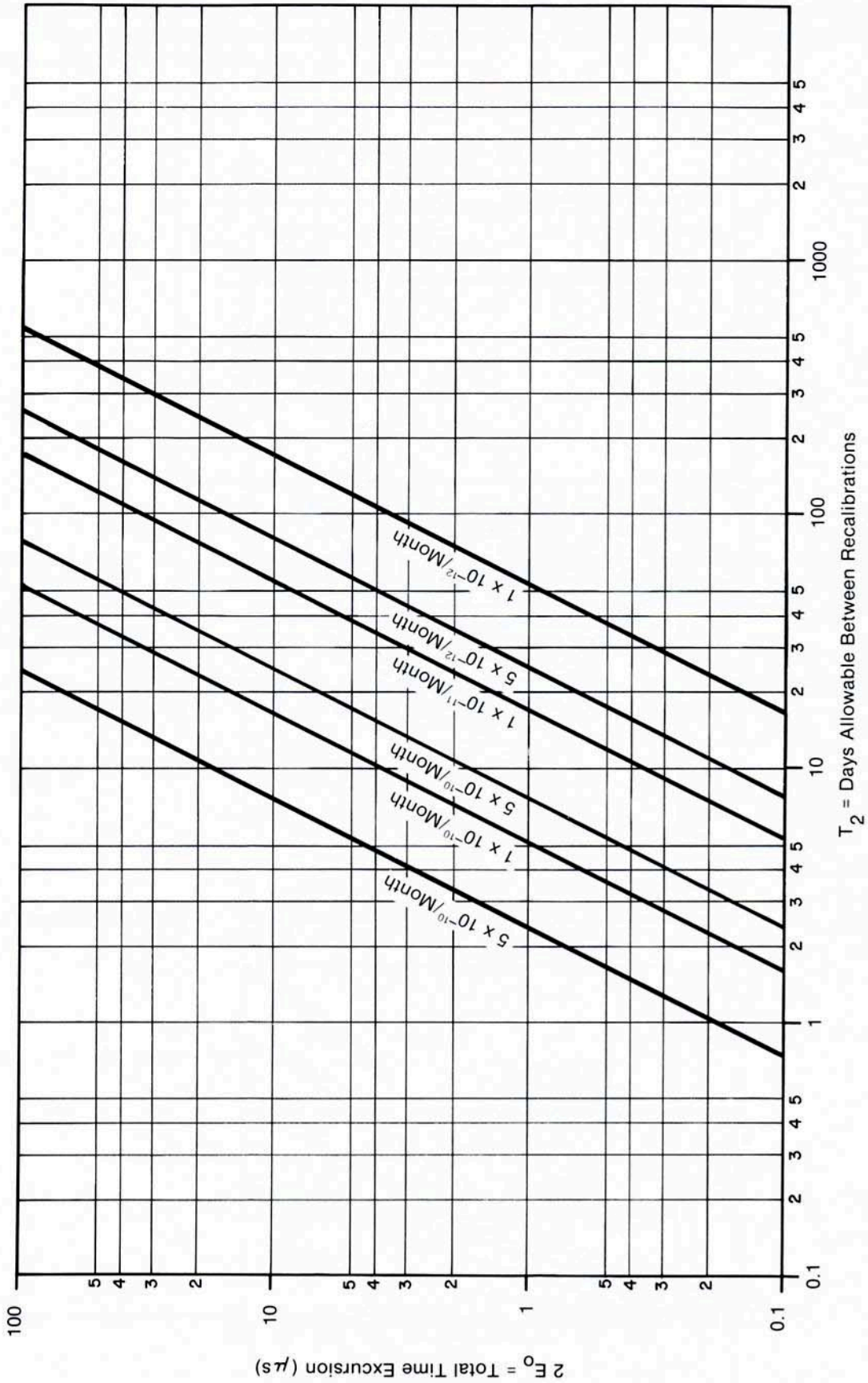

Figure C-2. Recalibration Chart for Rubidium Standards

To calculate the oscillator's frequency offset f_o , it is necessary to know T_1 . This value is easily computed from the value of T_2 , which has been read from the chart for the first example:

$$T_1 = \frac{T_2}{2} = \frac{60}{2} = 30 \text{ days}$$

$$f_o = f_r (1 - aT_1) = f_r [1 - (5 \times 10^{-10}) (30)]$$

$$= f_r [(1 - 150 \times 10^{-10})]$$

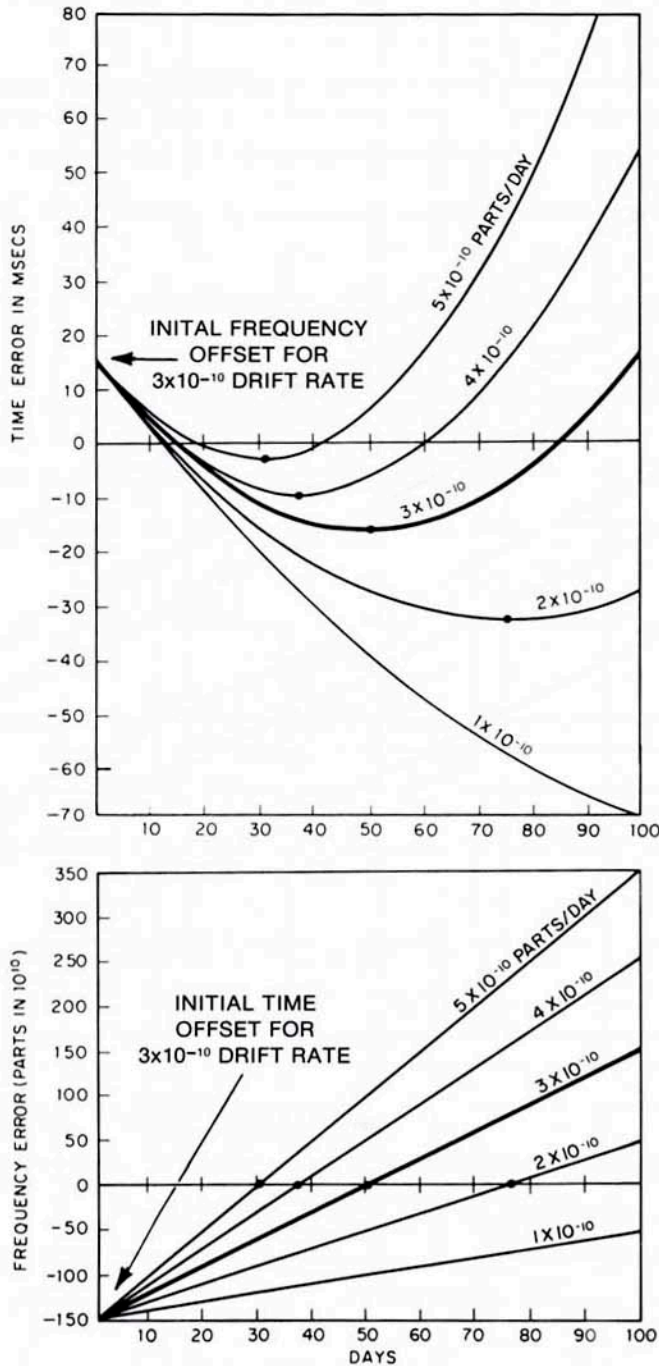

Figure C-3. Error Plots

Frequency offset is, then -150 parts in 10^{10} .

DRIFT RATE PREDICTION

It should be recognized that unless the drift rate actually is the one predicted for the oscillator, use of this method may enlarge rather than minimize error. Figure C-3 shows this effect.

In a typical case, frequency drift was assumed to be 3×10^{-10} , parts per day (heavy solid line); the initial frequency was offset -150 parts in 10^{10} and the initial time was offset 16 ms to minimize error over a 100-day period. The plots of Figure C-3 show the increased time error that would result if oscillator performance were at a drift rate other than the 3 parts in 10^{10} predicted say, at 1 , 2 , 4 or 5 parts in 10^{10} .

Caution should be exercised in using the derived recalibration times. The equations, as well as the charts, are based on constant conditions, e.g. temperature, humidity etc. Changing conditions can cause frequency changes which will impact on accumulated time.

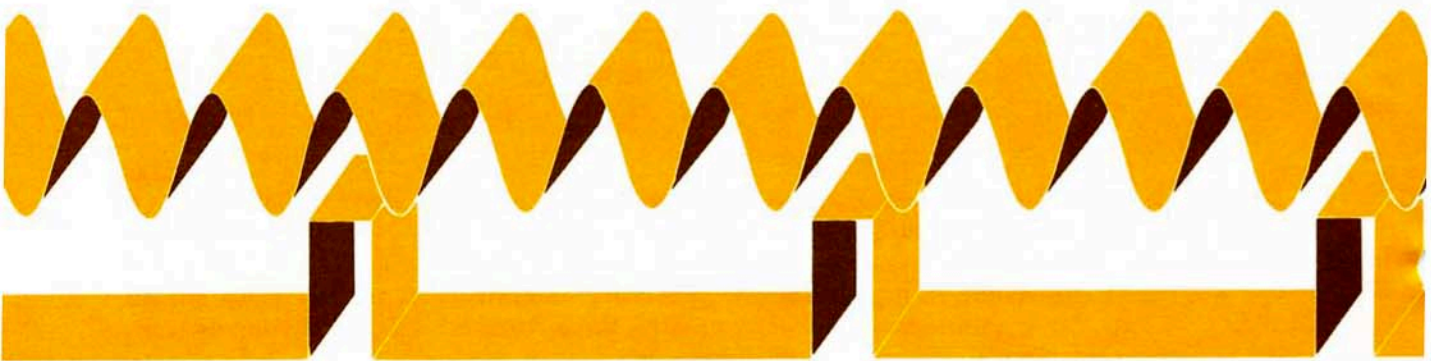

APPENDIX D

VARIANCE OF TIME INTERVAL FOR CALIBRATED CLOCKS*

We assume a calibration time interval, T_C , during which the system clock is compared against a reference to determine its average frequency. Following a dead time, T_d , the phase or time of the clock is measured and we wish to estimate the variance in the indicated time after an interval T_p where we assume the correction determined during the calibration is applied.

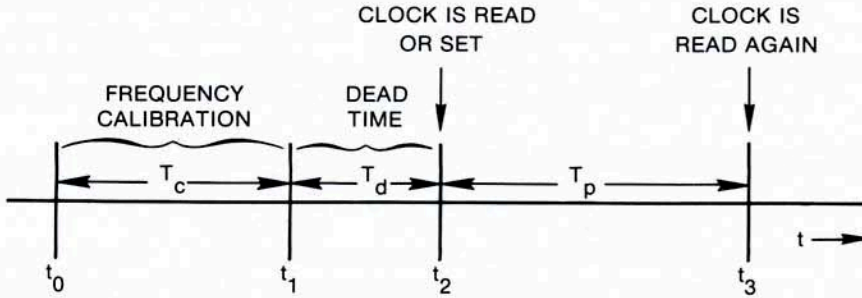

The frequency offset determined during the calibration interval is

$$\frac{\Delta f_C}{f_0} = \frac{\phi(t_1) - \phi(t_0)}{\omega_0 T_C} \quad (\text{Eq. 1})$$

$$\omega_0 = 2\pi f_0$$

where the reference clock is assumed to have output voltage

$$v_r = V_0 \cos \omega_0 t$$

and the system clock has

$$v_s = V_0 \cos [\omega_0 t + \phi(t)]$$

The time error, ϵ , developed during the time, T_p , after applying the correction factor is then just

$$\epsilon = T_p \left(\frac{\Delta f_p}{f_0} - \frac{\Delta f_C}{f_0} \right) \quad (\text{Eq. 2})$$

where

$$\frac{\Delta f_p}{f_0} = \frac{\phi(t_3) - \phi(t_2)}{\omega_0 T_p}$$

*Extracted from an unpublished paper, same title, by Dr. Len Cutler of Hewlett-Packard Laboratories, undated.

so that

$$\epsilon = \frac{T_p}{\omega_0} \left(\frac{\phi_3 - \phi_2}{T_p} - \frac{\phi_1 - \phi_0}{T_c} \right)$$

or

$$= \frac{1}{\omega_0} \left(\phi_3 - \phi_2 - (\phi_1 - \phi_0) \frac{T_p}{T_c} \right)$$

Now

$$\overline{\epsilon} = \frac{1}{\omega_0} \left(\overline{\phi_3 - \phi_2} - (\overline{\phi_1 - \phi_0}) \frac{T_p}{T_c} \right) = 0$$

and

$$\begin{aligned} \overline{\epsilon^2} &= \frac{1}{\omega_0^2} \left[\overline{\phi_3^2 + \phi_2^2} + \frac{T_p^2}{T_c^2} \left(\overline{\phi_1^2 + \phi_0^2} \right) \right. \\ &\quad \left. - 2 \overline{\phi_3 \phi_2} - \frac{2T_p}{T_c} \overline{\phi_3 \phi_1} + \frac{2T_p}{T_c} \overline{\phi_3 \phi_0} \right. \\ &\quad \left. + \frac{2T_p}{T_c} \overline{(\phi_2 \phi_1)} - \frac{2T_p}{T_c} \overline{\phi_2 \phi_0} - 2 \overline{\phi_1 \phi_0} \frac{T_p^2}{T_c^2} \right] \end{aligned}$$

ϵ is a stationary, Gaussian distributed random variable. Even though the phase is not stationary, we can say, using the autocorrelation function, $R(\tau)$:

$$\begin{aligned} \overline{\epsilon^2} &= \frac{2}{\omega_0^2} \left[R_\phi(0) \left(1 + \frac{T_p^2}{T_c^2} \right) - R_\phi(T_p) - \frac{T_p}{T_c} R_\phi(T_p + T_d) \right. \\ &\quad \left. + \frac{T_p}{T_c} R_\phi(T_p + T_d + T_c) + \frac{T_p}{T_c} R_\phi(T_d) - \frac{T_p}{T_c} R_\phi(T_c + T_d) \right. \\ &\quad \left. - \frac{T_p^2}{T_c^2} R_\phi(T_c) \right] \end{aligned}$$

Then

$$\begin{aligned} \overline{\epsilon^2} = & \frac{2}{\omega_0^2} \int_0^{\infty} df S_{\phi}(f) \left[1 + \frac{T_p^2}{T_c^2} - \cos 2\pi f T_p \right. \\ & - \frac{T_p}{T_c} \cos 2\pi f (T_p + T_d) + \frac{T_p}{T_c} \cos 2\pi f (T_p + T_d + T_c) \\ & + \frac{T_p}{T_c} \cos 2\pi f T_d - \frac{T_p}{T_c} \cos 2\pi f (T_c + T_d) \\ & \left. - \frac{T_p^2}{T_c^2} \cos 2\pi f T_c \right] \end{aligned} \quad (\text{Eq. 3})$$

or

$$\overline{\epsilon^2} = \frac{2}{\omega_0^2} \int_0^{\infty} df S_{\phi}(f) K(f, T),$$

since

$$R_{\phi}(\tau) = \int_0^{\infty} S_{\phi}(f) \cos 2\pi f \tau df ,$$

where $S_{\phi}(f)$ is the one-sided spectral density of phase.

Let

$$S_y(f) = A + \frac{B}{f} \quad (\text{Eq. 4})$$

where

$$S_y(f) = \frac{S_{\phi}(f)}{\omega_0^2} = \frac{f^2 S_{\phi}(f)}{f_0^2}$$

$S_y(f)$ is the fractional frequency spectral density. The phase spectral density is then

$$S_{\phi}(f) = \frac{f_0^2}{f^2} S_y(f)$$

Using Equation (4) in Equation (3), we get

$$\overline{\epsilon^2} = \frac{2}{4\pi^2} \int_0^{\infty} df \left(\frac{A}{f^2} + \frac{B}{f^3} \right) K(f, T) ,$$

white frequency
flicker frequency

where $K(f,T)$ is defined in Equation (3). The white part gives

$$\overline{\epsilon_w^2} = \frac{1}{2} A \left(T_p + \frac{T_p^2}{T_c} \right) = \frac{1}{2} A T_p \left(1 + \frac{T_p}{T_c} \right) \quad (\text{Eq. 5})$$

The flicker part gives

$$\begin{aligned} \overline{\epsilon_f^2} = B T_p^2 & \left[\frac{(T_p + T_d + T_c)^2 \ln \left(1 + \frac{T_p + T_d}{T_c} \right) + \frac{T_d^2}{T_c T_p} \ln \frac{T_d}{T_c}}{T_p T_c} \right. \\ & - \ln \frac{T_p}{T_c} - \frac{(T_p + T_d)^2 \ln \left(\frac{T_p + T_d}{T_c} \right)}{T_p T_c} \\ & \left. - \frac{(T_c + T_d)^2 \ln \left(1 + \frac{T_d}{T_c} \right)}{T_p T_c} \right] \quad (\text{Eq. 6}) \end{aligned}$$

Typical values for A and B are

5061A	5061A Opt. 004	5062C
$A \approx 1 \times 10^{-20} \text{ sec}$	$1.28 \times 10^{-22} \text{ sec}$	$1 \times 10^{-20} \text{ sec}$
$B \approx 2.88 \times 10^{-26}$	6.5×10^{-28}	1.8×10^{-25}

The value for A is that at the end of beam tube life and that for B is an estimate of what one might expect for a typical non-controlled laboratory type of environment.



APPENDIX E

DAILY PHASE VALUES AND TIME DIFFERENCES SERIES 4

U.S. NAVAL OBSERVATORY
WASHINGTON, D.C. 20390

11 SEPTEMBER 1975

DAILY PHASE VALUES AND TIME DIFFERENCES SERIES 4

NO. 449

REFERENCES: (A) TIME SERVICE INFORMATION LETTER OF 15 AUGUST 1973
(B) TIME SERVICE ANNOUNCEMENT, SERIES 9, NO. 36 (LORAN-C)
(C) DAILY PHASE VALUES AND TIME DIFFERENCES, SERIES 4, NO. 389 (LORAN-D)
(D) DAILY PHASE VALUES AND TIME DIFFERENCES, SERIES 4, NO. 195 (TV)

THE TABLE GIVES: UTC(USNO MC) - TRANSMITTING STATION

UNIT = ONE MICROSECOND

*MEASURED BY USNO TIME REFERENCE STATIONS AND OTHER MONITORING ACTIVITIES WHICH ARE WITHIN GROUND WAVE RANGE. THESE VALUES ARE CORRECTED TO REFER TO USNO MASTER CLOCK.
**COMPUTED FROM DIFFERENTIAL PHASE DATA PROVIDED BY US COAST GUARD STATIONS AND OTHER MONITORING ACTIVITIES. THESE VALUES ARE CORRECTED TO REFER TO USNO MASTER CLOCK.

FREQUENCY KHZ (UTC)	MJD	LORAN-C*	LORAN-C*	LORAN-C	LORAN-C**	LORAN-C**	LORAN-C
		9970 NORTHWEST PACIFIC 100	4990 CENTRAL PACIFIC 100	9930 EAST COAST U.S.A. 100	7970 NORWEGIAN SEA 100	7990 MEDITERRANEAN SEA 100	7930 NORTH ATLANTIC 100
AUG. 27	42651	1.1	2.9	1.82	1.9	1.3	1.6
28	42652	1.1	2.9	1.84	1.8	1.2	1.6
29	42653	1.0	2.9	1.88	1.9	1.3	1.5
30	42654	1.2	2.9	1.91	2.0	1.4	1.4
31	42655	1.3	2.9	1.91	2.0	1.5	1.5
SEP. 1	42656	1.5	3.0	1.93	2.0	1.6	1.5
2	42657	1.4	3.0	1.91	2.0	1.6	1.6
3	42658	1.4	3.1	1.90	2.1	1.6	1.6
4	42659	1.5	3.1	1.90	2.2	1.7	1.6
5	42660	1.6	3.2	1.89	2.1	1.7	1.6
6	42661	1.6	3.1	1.90	2.1	1.6	1.7
7	42662	1.7	3.2	1.87	2.1	1.5	1.5
8	42663	1.6	3.3	1.78	2.1	1.6	1.5
9	42664	1.9	3.2	1.76	2.1	-	1.6
10	42665	1.9	3.3	1.75	2.0	-	1.5

FREQUENCY KHZ (UTC)	MJD	LORAN-C*	LORAN-D	6	7	5
		5930 NORTH PACIFIC 100	4930 WEST COAST U.S.A. 100	OMEGA ND 10.2 6,000+	OMEGA ND 13.1 6,000+	OMEGA ND 13.6 6,000+
AUG. 27	42651	-4.8	9.3	443	444	445
28	42652	-4.7	9.5	443	444	445
29	42653	-4.7	9.6	443	444	445
30	42654	-4.7	-	443	444	445
31	42655	-4.7	-	442	443	445
SEP. 1	42656	-4.7	-	442	445	445
2	42657	-4.7	10.1	-	-	-
3	42658	-4.7	10.2	-	-	-
4	42659	-4.7	10.4	-	-	-
5	42660	-4.7	10.5	-	-	-
6	42661	-4.7	-	-	-	-
7	42662	-4.7	-	-	-	-
8	42663	-4.7	11.0	-	-	-
9	42664	-	11.2	-	-	-
10	42665	-	11.4	-	-	-

FREQUENCY KHZ (UTC)	MJD	1	4	2	3	8	WASHINGTON, DC
		OMEGA T 13.6 11,000+	GER 16.0 19,000+	NAA 17.8 3,000+	NLK 18.6 12,000+	NRA 24.0 10,000+	WTTG *** CHANNEL 5 EMITTED
SEP. 4	42659	647	516	209	586	820	-1.40
5	42660	647	516	209	589(NOTE 1)	820	-1.48
6	42661	647	515	210	588	820	-1.52
7	42662	647	515	210	588	820	-1.48
8	42663	647	515	209	588	820	-1.45
9	42664	647	514	208	588	820	-1.45
10	42665	647	513	208	588	820	-1.33

DAILY PHASE VALUES AND TIME DIFFERENCES SERIES 4, NO. 449 (CONTINUED)

*** CHANNEL 5 (WTTG) READINGS.

THE VALUES GIVEN REPRESENT AN AVERAGE OF 30 MEASUREMENTS DURING THE 30 SECOND INTERVAL BEFORE 17H 10M 43S UT. IF THESE TOAS HAPPEN TO FALL INTO A NON-SYNCHRONIZED PROGRAM, THE 30 TOAS BEFORE 16H 10M 43S HAVE BEEN USED. A THIRD MEASUREMENT, BEFORE 16H 10M 43S IS ALSO AVAILABLE ON REQUEST.

		NATIONAL TELEVISION NETWORKS					
		NBC	NBC	CBS	CBS	ABC	ABC
		19:25:00 UT	19:31:00 UT	19:26:00 UT	19:32:00 UT	19:27:00 UT	19:33:00 UT
SEP.	MJD						
4	42659	13,981.8	6,959.3	20,704.1	13,681.4	1,966.5	28,310.7
5	42660	30,288.0	23,265.6	3,597.3	29,941.3	18,266.7	11,244.1
6	42661	13,227.7	6,205.2	19,856.2	12,835.5	24,899.2	17,733.2
7	46662	14,824.9	7,814.2	2,751.4	29,095.4	6,770.1	32,971.1
8	42663	12,474.5	5,452.1	19,010.7	11,988.0	433.0	26,799.4
9	42664	28,781.0	21,758.6	1,903.6	28,247.6	16,733.0	9,710.4
10	42665	11,721.0	4,698.4	18,163.3	11,140.6	33,032.9	26,010.4

NOTES: (1) NLK 4 SEP. AFTER MAINTENANCE PERIOD STEP ABOUT PLUS 3

(2) NAVY STATIONS OFF-AIR TIMES:

NCA 5 SEP. 0827 TO 0829 UT
 6 SEP. 2033 TO 2034 UT
 NAA 9 SEP. 1751 TO 1800 UT

NBA WAS UNSTABLE 4 SEP. ABOUT 1820 TO 1630 UT.
 NAA'S WEEKLY MAINTENANCE PERIOD WAS ON 8 SEP. INSTEAD OF 5 SEP.

(3) OMEGA STATION OFF-AIR TIME:

TRINIDAD 3 SEP. 0531 TO 0533 UT

(4) (9930-Z) EAST COAST LORAN-C SLAVE DANA, INDIANA WAS UNSTABLE 4 SEP. 0130 TO 0214 UT.

(5) (9930-X, 7930-Z) EAST COAST AND NORTH ATLANTIC LORAN-C SLAVE CAPE RACE, NEWFOUNDLAND WAS OFF THE AIR/UNSTABLE FOR PERIODS BETWEEN THE FOLLOWING TIMES:

5 SEP. 1030 AND 1848 UT
 6 SEP. 0958 AND 1923 UT
 7 SEP. 1200 AND 1903 UT
 8 SEP. 0946 AND 1941 UT
 9 SEP. 1007 AND 1937 UT.

(6) (9930-Y) EAST COAST LORAN-C SLAVE NANTUCKET ISLAND, MASSACHUSETTS WAS OFF THE AIR 6 SEP. 1401 TO 1558 UT.

(7) (4990-Y) CENTRAL PACIFIC LORAN-C SLAVE KURE, MIDWAY ISLANDS WAS/IS SCHEDULED TO BE OFF THE AIR 8 SEP. 1700 UT TO 9 SEP. 0100 UT AND 12 SEP. 1900 UT TO 13 SEP. 0100 UT.

(8) (7990-H) MEDITERRANEAN SEA LORAN-C MASTER CATANZARO (SINERI CRICHI), ITALY WAS SCHEDULED TO BE OFF THE AIR 10 SEP. 0700 TO 0900 UT.

(9) (9970-H) NORTHWEST PACIFIC LORAN-C MASTER IWO JIMA IS SCHEDULED TO BE OFF THE AIR 11 SEP. 2000 TO 2100 UT.

(10) (4990-H) CENTRAL PACIFIC LORAN-C MASTER JOHNSTON ISLAND IS SCHEDULED TO BE OFF THE AIR 12 SEP. 2300 UT TO 13 SEP. 0100 UT.

(11) (4990) CENTRAL PACIFIC LORAN-C CHAIN IS SCHEDULED TO BE ADVANCED 3.0 MICROSECONDS 20 SEP. AT 2000 UT.

(12) (4930) WEST COAST U.S.A. LORAN-D WAS INCREASED IN FREQUENCY BY APPROXIMATELY 2.5 PARTS IN TEN TO THE MINUS TWELVE ON 10 SEP.

APPENDIX F

DERIVATION OF FRACTIONAL FREQUENCY DEVIATION EQUATION

Starting with the basic definition of frequency

$$f = \frac{1}{\tau} = \tau^{-1}$$

where:

f = frequency, Hz

τ = period, s

Differentiating:

$$df = -\tau^{-2} d\tau = -\frac{d\tau}{\tau^2}$$

$$df = -\frac{d\tau}{\tau} f$$

$$\frac{df}{f} = -\frac{d\tau}{\tau}$$

from which we can, for small changes, write the approximation:

$$\frac{\Delta f}{f} = -\frac{\Delta \tau}{\tau}$$

where

$\frac{\Delta f}{f}$ = fractional frequency deviation (dimensionless)

$\Delta \tau$ = change in time accumulated over the measurement time, τ .

Also since time can be measured from an accumulation of phase of a reference oscillator:

$$\frac{\Delta \tau}{\tau} = \frac{\Delta \phi}{\phi}$$

where $\Delta \phi$ = change in phase over the total accumulated phase, ϕ , due to the reference frequency.

Which leads to the final approximation

$$\frac{\Delta f}{f} = -\frac{\Delta \tau}{\tau} = -\frac{\Delta \phi}{\phi}$$

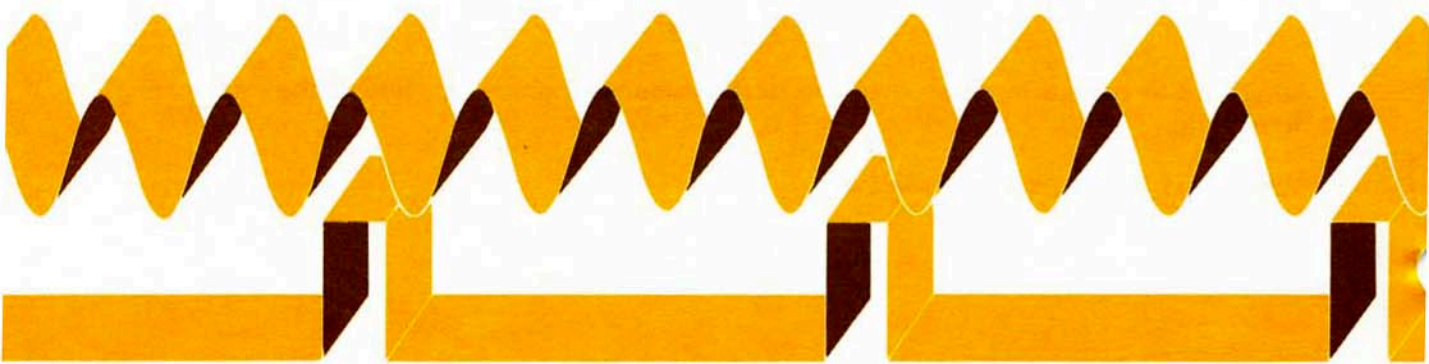

APPENDIX G

BIBLIOGRAPHY

GENERAL

- (1) Allan, D.W. et al., "Precision and Accuracy of Remote Synchronization via Network Television Broadcasts, Loran-C, and Portable Clocks". *Metrologia*, Vol. 8 No. 2 pp. 64-72, 1972.
- (2) Baugh, R.A. and Cutler, L.S., "Precision Frequency Sources", *The Microwave Journal*, pp. 43-56, June 1970.
- (3) Begley, W.W. and Shapiro, A.H., "Aspects of Precision Timing Systems", The Aerospace Corporation, October 1969.
- (4) Blair, B.E. (Ed.) *Time and Frequency: Theory and Fundamentals*, NBS Monograph 140, USGPO, May 1974.
- (5) Bureau International de l'Heure (BIH) Annual Report 1972, BIH, 1973.
- (6) Jespersen, J.L., Blair, B.E., and Gatterer, L.E., "Characterization and Concepts of Time-Frequency Dissemination", *IEEE Proceedings*, Vol. 60, No. 5, pp. 502-521, May 1972.
- (7) Jespersen, J.L. and Fey, L., "Time Telling Techniques", *IEEE Spectrum*, pp. 51-58, May 1972.
- (8) *Operating Procedures for PTTI Equipments*, U.S. Naval Observatory Time Service Division, June 1973.
- (9) Putkovich, K., "Automated Timekeeping", *IEEE Transactions on Instrumentation and Measurement*. Vol. 1M-21, No. 4, November 1972.
- (10) Winkler, G.M.R., "Path Delay, Its Variations and Some Implications for the Field Use of Precise Frequency Standards", *IEEE Proceedings*, Vol. 60, No. 5, pp. 522-529, May 1972.

LORAN-C

- (11) Day, Richard A., Jr., "Use of Loran-C Navigational System as a Frequency Reference", *Signal*, pp. 26-30, November 1973.
- (12) Hefley, C. *The Development of Loran-C Navigation and Timing*, NBS Monograph 129, USGPO, October 1972.
- (13) *Loran-C Manual*, Austron, Inc., March 1974.
- (14) Potts, C.E., and Wieder, B., "Precise Time and Frequency Dissemination via the Loran-C System". *IEEE Proceedings*, Vol. 60, No. 5, pp. 530-539, May 1972.
- (15) Shapiro, L. Dennis, "Time Synchronization from Loran-C", *IEEE Spectrum*, Vol. 5 No. 8, pp. 46-55, August 1968.

OMEGA

- (16) Swanson, E.R. and Kugel, C.P., "VLF Timing: Conventional and Modern Techniques Including Omega", *IEEE Proceedings*, Vol. 60, No. 5, pp. 540-551, May 1972.

TELEVISION

- (17) Allan, D.W., Machlan, H.E., and Marshall, J., "Time Transfer Using Nearly Simultaneous Reception Times of a Common Transmission", *Proceedings of 26th Annual Symposium on Frequency Control*, pp. 309-316, Electronics Industries Association, Washington, D.C. 1972.
- (18) Lavanceau, J.D., *Time Measurements via Television*, USNO, Washington, D.C., November 1972.

SATELLITE

- (19) Lavanceau, J.D., and Carroll, D., "Real Time Synchronization via Passive Television Transmission". Proceedings 3rd Annual Precise Time and Time Interval (PTTI) Strat. Plan. Mtg. (November 16-18, 1971), USNO, Washington, D.C., pp. 331-366, 1972.
- (20) Leschiutta, S., "Long Term Accuracy of Time Comparisons via TV Signal Along Radio Relay Links", IEEE Transactions on Instrumentation and Measurement. Vol. 1M-22, No. 1, pp. 84-87, March 1973.
- (21) Tolman, J. et al., "Microsecond Clock Comparison by Means of TV Synchronization Pulses". IEEE Transactions on Instrumentation and Measurement. Vol. 1M-16, No. 3, pp. 247-254, September 1967.
- (22) Easton, R.L., "The Role of Time/Frequency in Navy Navigation Satellites", IEEE Proceedings, Vol. 60, No. 5, pp. 557-563, May 1972.
- (23) Ehrlich, E., "The Role of Time/Frequency in Satellite Position Determination Systems", IEEE Proceedings, Vol. 60, No. 5, pp. 564-571, May 1972.
- (24) Jespersen, J.L. et al., "Satellite VHF Transponder Time Synchronization", IEEE Proceedings, Vol. 56, No. 7, pp. 1202-1206, July 1968.
- (25) Markowitz, W. et al., "Clock Synchronization via Relay II Satellite", IEEE Transactions on Instrumentation and Measurement". Vol. 1M-15, No. 4, pp. 177-184, December 1966.
- (26) Steele, J. McA., Markowitz, W. and Lidbach, C.A., "Telstar Time Synchronization", IEEE Transactions on Instrumentation and Measurement. Vol. No. pp. 164-170, December 1964.
- (27) Higa, W.H., "Time Synchronization via Lunar Radar", IEEE Proceedings, Vol. 60, No. 5, pp. 552-557, May 1972.
- (28) Phillips, D.H., Phillips, R.E., and O'Neill, J.J., "Time and Frequency Transfer via Microwave Link", IEEE Transactions on Instrumentation and Measurement, Vol. 1M-20, No. 1, pp. 23-28, February 1971.
- (29) Sanders, W.R. et al., "A Meteor Burst Clock Synchronization Experiment". IEEE Transactions on Instrumentation and Measurement. Vol. 1M-15, No. 4, pp. 184-189, December 1966.

ACKNOWLEDGEMENTS

The author is grateful for the contributions of many individuals in compiling this volume of AN 52. The guidance and contributions of Ron Hyatt, Joe Bourdet, Mike Fischer, and Jim Marshall of the Hewlett Packard Company Santa Clara Division are greatly appreciated. Special thanks go to Dr. Len Cutler of Hewlett Packard Laboratories for his treatise on "The Variance of Time Interval for Calibrated Clocks". Special thanks must go to personnel of the U.S. National Bureau of Standards and the U.S. Naval Observatory for their help and review.

Terry Osterdock



For more information, call your local HP Sales Office or East (301) 948-6370 • Midwest (312) 677-0400 • South (404) 434-4000 • West (213) 877-1282. Or, write: Hewlett-Packard, 1501 Page Mill Road, Palo Alto, California 94304. In Europe, Post Office Box 349, CH-1217 Meyrin 1, Geneva, Switzerland. In Japan, Yokogawa-Hewlett-Packard, 1-59-1, Yoyogi, Shibuya-Ku, Tokyo, 151.

02-5952-7409

NOVEMBER 1975
REVISED AUG 1979

PRINTED IN U.S.A.