



APPLICATION NOTES

APPLICATION NOTE 51

MODIFIED 485B PROVIDES CONVENIENT AND ECONOMICAL MIXER FOR X- AND H-BAND LABORATORY RECEIVERS

MODIFICATION PROCEDURE

For many laboratory measurements (such as large values of attenuation) video detection sensitivity does not provide sufficient dynamic range. Linear detection by means of receiver techniques can be used to overcome this limitation. A convenient laboratory receiver for X- and H-band work can be assembled from standard Φ waveguide shelf components using a modified 485B Crystal Detector Mount as the mixer. This Application Note describes the modification for the 485B and shows how the detector can be used in a complete receiver arrangement.

Noise figures as low as 12 to 15 db can be obtained for laboratory receivers using a modified X485B or H485B crystal detector mount as the receiver mixer. The modification, as described below, consists of replacing a factory-installed brass slug with an equivalent slug of rexolite (or similar plastic) machined to proper dimensions. A noise figure meter may be used to obtain optimum noise figure with the modified 485B mixer. Typical detection sensitivities run between -90 and -100 dbm when used with a 1 mc IF bandwidth such as the Φ K01 344A IF Amplifier.

Figure 1 shows interior detail of the X485B and H485B crystal holder. The "contact guide" is a brass slug

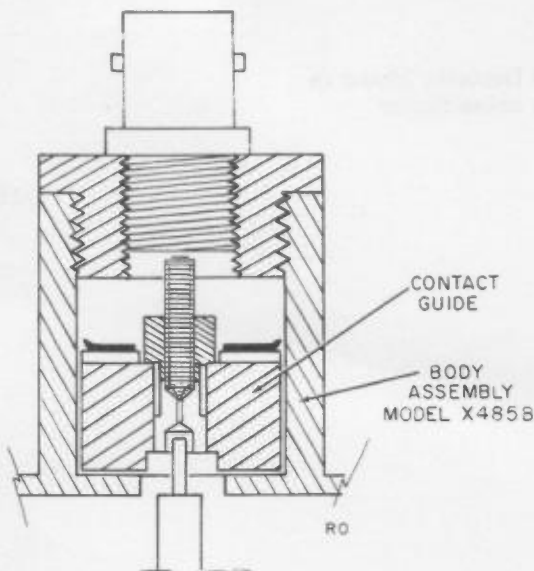

Figure 1. Rexolite insert can replace brass contact guide of Φ X485B or H485B Detector Mount to provide inexpensive mixer for laboratory receiver.

insulated from the body assembly by a tape wrapping. Output capacity with this construction is of the order of 100 to 125 pf. This is adequate for the unit's normal use as a 1000 cycle detector, but is much too high for use as a mixer providing a 30 mc output into a receiver IF strip.

The output capacity can be greatly reduced by replacing the brass contact guide slug with an equivalent rexolite part machined to the dimensions shown in figure 2.

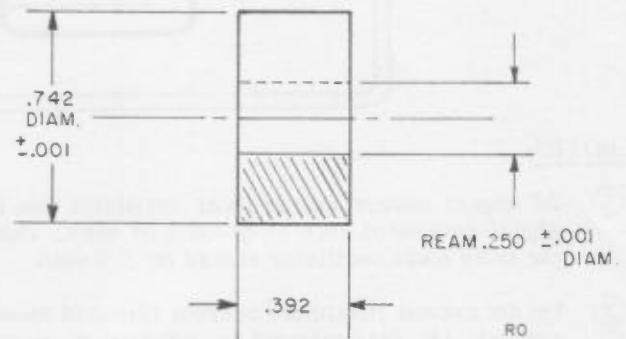

Figure 2. Dimensions for machining Rexolite insert

ADJUSTING MIXER FOR OPTIMUM NOISE FIGURE

Noise figure of a modified X485B can be optimized by using an Φ Model 340B Noise Figure Meter and associated Model 347A Noise Source. The instruments are connected to the laboratory receiver components as indicated in figure 3. The decoupling filter and dc bias circuitry provides a bias return for crystal current. Noise figure is then minimized by adjusting the five controls shown until the best combination of settings is established.

OTHER BANDS

The procedure outlined in this application note has been used in the Φ engineering laboratories to provide mixers for X- and H-band work where video detection does not provide sufficient sensitivity. The basic technique is also applicable to using G485B and J485B crystal detector mounts as mixers in their respective bands. However, because of the larger waveguide size, the guide contact slug is of a different shape (extending into the waveguide area) and the procedure for obtaining optimum noise figure may be more difficult.

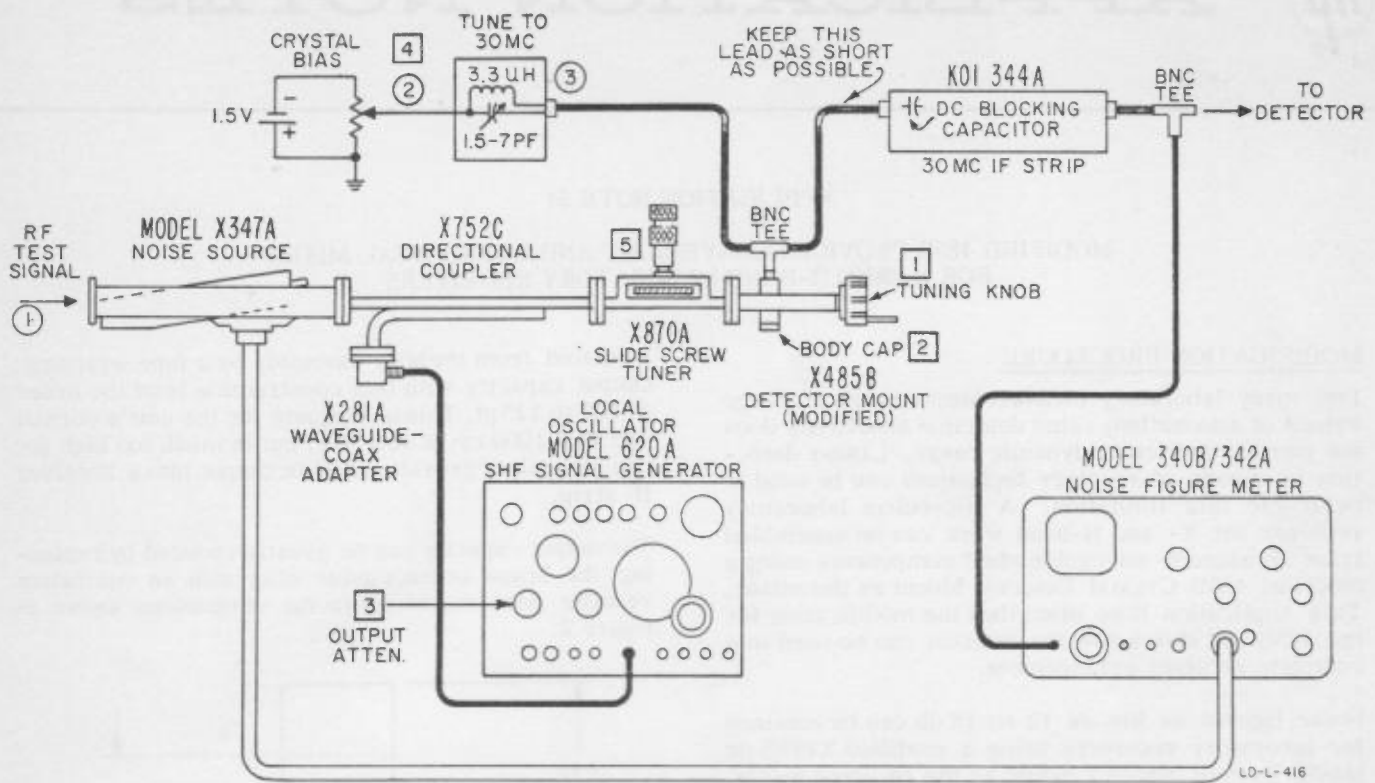

NOTES:

- ① RF signal source and/or local oscillator can be signal generator such as 620A or 686A. Output from local oscillator should be > 0 dbm.
- ② Do not exceed maximum current rating of mixer crystal. DC bias may not be required if enough self bias current can be obtained from L.O. drive.
- ③ Decoupling filter should be in shielded can.

- 1
- 2
- 3
- 4
- 5

These five controls are adjusted to obtain optimum noise figure as indicated on noise figure meter.

Figure 3. Adjusting modified X485B Detector Mount in laboratory receiver for optimum noise figure

1/15/61

WRS