



APPLICATION NOTES

APPLICATION NOTE 50

MAKING VLF FREQUENCY COMPARISON MEASUREMENTS WITH Φ LABORATORY EQUIPMENT

I INTRODUCTION

When calibrating a local frequency standard against the transmissions from a standard radio station, the necessary comparison can be made by either of two basic methods. These are frequency comparison and time comparison. Although frequency comparison with the carrier of one of the high frequency standard stations such as WWV or WWVH is more widely used, this method suffers in accuracy because of the problem of doppler shift. That is, the maximum accuracy achievable is determined by the uncertainty that variations in the transmission medium introduce into the transmission. For the usual case of sky-path transmission, the frequency, as received, can be different from that transmitted by up to several parts in 10^7 because of ionosphere movement and other effects.

Clearly, a different approach is required if the full capabilities of present-day local standards are to be utilized. Two methods are used. In the first, local standard calibration can be made on a time comparison basis. Utilizing the one-second ticks transmitted by most hf standard stations, a measurement is made of the time variations that occur over an interval of one or more days between a time signal derived from the local standard oscillator and the time signal as received from the standard station. In this way, propagation effects are integrated or averaged. Time comparisons made over several days can yield comparison accuracies¹ of a few parts in 10^{10} .

The second approach to the doppler shift problem is to make frequency comparison against the vlf standard stations such as NBA and WWVL. VLF transmissions are virtually free of the propagation problems encountered with hf signals and may usually be neglected.² To realize a comparison accuracy of one part in 10^9 by the time comparison method, using hf standard

stations, would ordinarily require measurements made over a period of several days. With the equipment and techniques described in this note, a comparison accuracy of one part in 10^9 may usually be achieved in less than one hour. Longer tests can increase the accuracy proportionally. A short comparison period simplifies calibration and minimizes equipment needs. A plot of several days' measurements may be made if the stability capability of the local standard warrants it.

This application note describes a simple method of vlf frequency comparison using Φ instruments available in many laboratories.

II VLF FREQUENCY COMPARISON

A. EQUIPMENT SETUP

Frequency comparison against vlf signals may be made using the equipment shown in figure 1. The method is convenient, automatic, and can provide a continuous record.

Note that although the measurements described here are of the frequency comparison type, local standard installations will ordinarily include a synchronous clock. The Φ Model 113AR Clock, in conjunction with the Φ Model 103AR, or other suitable oscillator, permits time to be kept on a local basis to within a millisecond of national standards. It also, of course, provides the capability to make alternate checks against hf standard broadcasts by the time comparison method. However, time synchronization is beyond the scope of this application note which describes the use of the Φ 113AR Clock as a frequency divider and phase shifter to facilitate the vlf carrier frequency comparisons (see figure 2).

1) Using the Φ 302A as a VLF Receiver. The Φ 302A Wave Analyzer is a highly selective tuned voltmeter having a sensitivity of 10 microvolts or better. When used with an appropriate antenna, its range of 0.02-50 KC makes it a convenient vlf receiver. Operation in the afc mode locks the 302A to the vlf carrier.³ The time interval stop signal is taken directly from the 302A output BNC.

In certain geographical areas, the signal strength may be low enough to require the use of an amplifier

³Care should be taken when tuning, however. Large errors in the initial setting of the 302A dial to the vlf carrier frequency can, in some cases, result in an error in the reconstructed frequency at the 302A output connector.

¹Dexter Hartke, "A New Clock for Improving the accuracy of Local Frequency and Time Standards", Φ Journal, Vol. 11, No. 3-4, Nov-Dec, 1959.

²Studies have shown that vlf transmission path phase is very stable when neither sunrise or sunset is present along the path, and during the all sunlight period the path phase is much more stable than the path at night.

An excellent discussion of path phase variability for vlf transmissions appears in NBS Report #6091, World-Wide Standard Frequency and Line Signal Broadcasting by A. D. Watt and others.

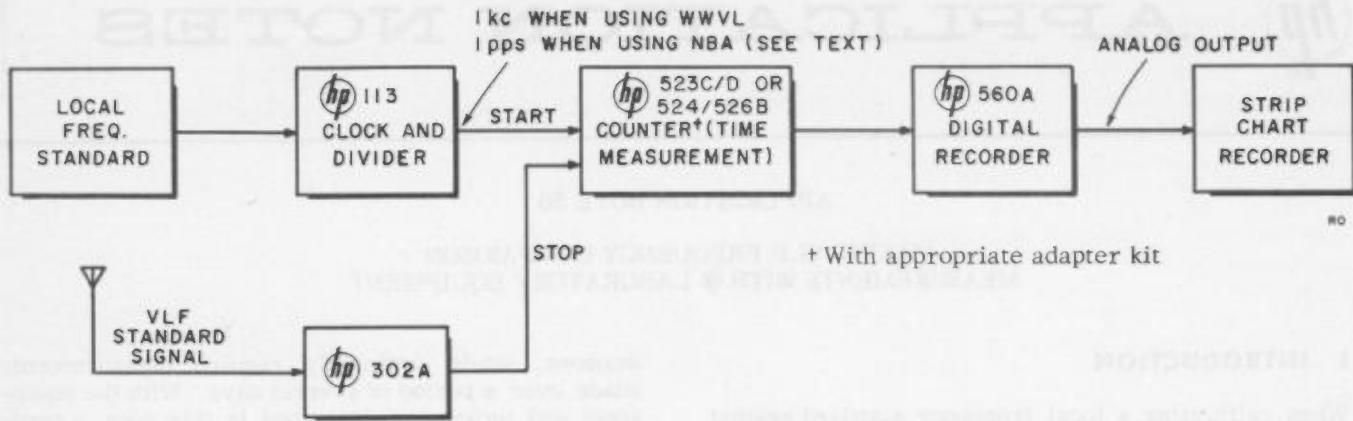

Figure 1. Block Diagram of VLF Frequency Comparison Setup

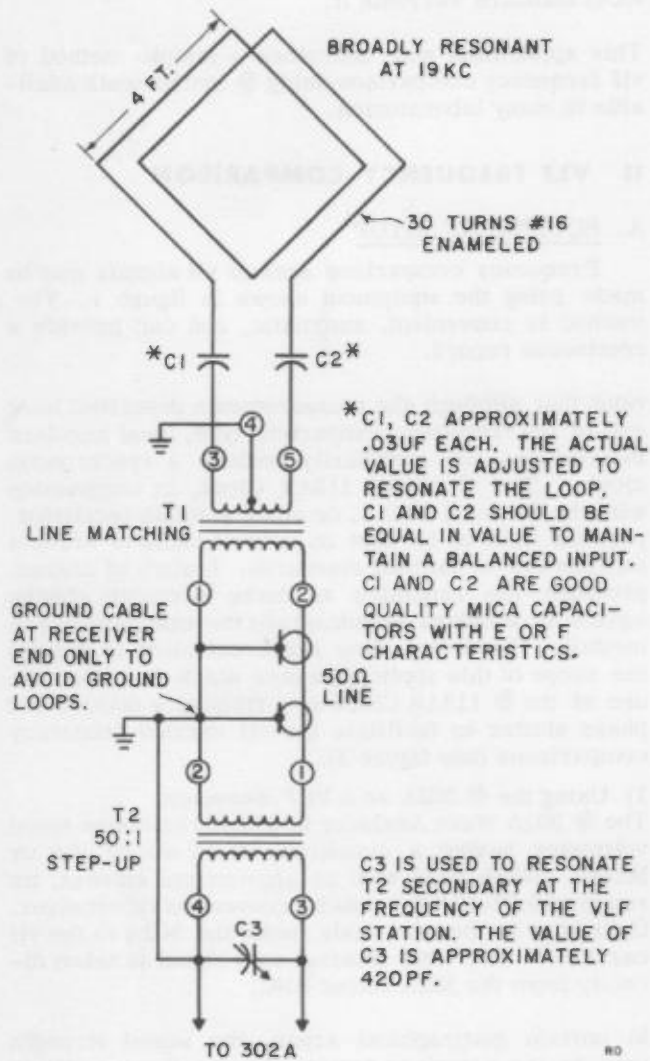

Figure 2. VLF Loop Antenna for the Model 302A

TABLE I. WINDING INSTRUCTIONS

Impedance	Turns	Wire	Core
T ₁			
Primary 23 ohms	112CT*	#32 Heavy Formvar	Genalex 657N**
Secondary 50 ohms	168	#32 Heavy Formvar	
T ₂			
Primary 50 ohms	24	#24 Heavy Formvar	Genalex 657N**
Secondary 100K ohms	1050	#38 Heavy Formvar	
Winding Instructions: T ₁ Wind secondary first. Wind bifilar primary over secondary. Label leads T ₂ Wind primary first. Wind secondary over primary.			
* Bifilar wound - double the wire and wind 56 turns ** Genalex core manufactured by: Salford Electrical Instruments, Ltd. Times Mill, Heywood, Laves, England			
Available from: Wallace E. Connolly and Co. P. O. Box 295, Menlo Park, Calif.			

such as the 450A or 466A between the 302A and the time interval meter to assure sufficient amplitude for reliable stop channel triggering.

2) The Antenna.

The easily-constructed antenna illustrated in figure 2 may be used to feed the 302A. Approximate component and impedance values are shown in this drawing along with other important construction details. See figure 3 for a photograph of a unit constructed at Hewlett-Packard Company. A simple cross bar of wood, aluminum, or other non-magnetic material is all that is needed for support.

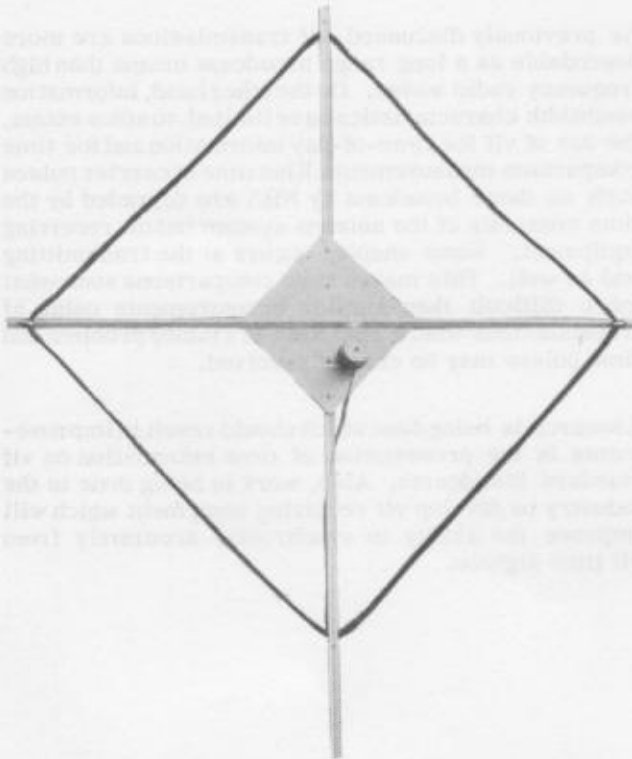

Figure 3. Photograph of Loop Antenna

B. TECHNIQUES OF FREQUENCY COMPARISON MEASUREMENTS

1) WWVL. The National Bureau of Standards VLF station, WWVL, broadcasts cw at 20 KC from Boulder, Colorado. Comparison measurements are made in this case by using the 1 KC output from the 113AR clock or other divider to start the time interval meter, and the 20 KC carrier to stop the time interval measurement. The time interval meter trigger level and slope controls permit selecting given and repeatable points on the start and stop signals. An analog record of the time interval meter readings gives the relative time drift of the oscillator under test as compared to WWVL.⁴

Figure 4 is a strip chart analog recording of a typical setup, comparing a local standard against WWVL. Here we see a change in the average value of the time interval measurements of 4 microseconds over a period of 2 hours. This corresponds to a frequency offset in the local standard of

$$\frac{\Delta F}{F} = \frac{\Delta T}{T} = \frac{4 \mu s}{7.2 \times 10^9} \approx 5 \text{ parts in } 10^{10}.$$

The large pips are the result of WWVL identification modulation, spaced 20 minutes apart. Chart speed is 7-1/2 inch per hour on a Varian G11 Recorder.

The absolute accuracy of the oscillator thus calibrated is dependent upon the absolute accuracy of the standard time signal, in addition to the accuracy of comparison. Furthermore, the stability of the local

⁴The comparison accuracy may be arrived at in the following way: Since there are approximately 4×10^9 microseconds in one hour, a frequency difference between local and standard of one part in 10^9 would result in a time drift of about 4 microseconds in one hour. The jitter on the 113AR tick is less than one microsecond and the time interval measurement on a one-megacycle counter may be made to within a few microseconds. Thus, it is possible to achieve a comparison accuracy of one part in 10^9 in a test covering only about one hour.

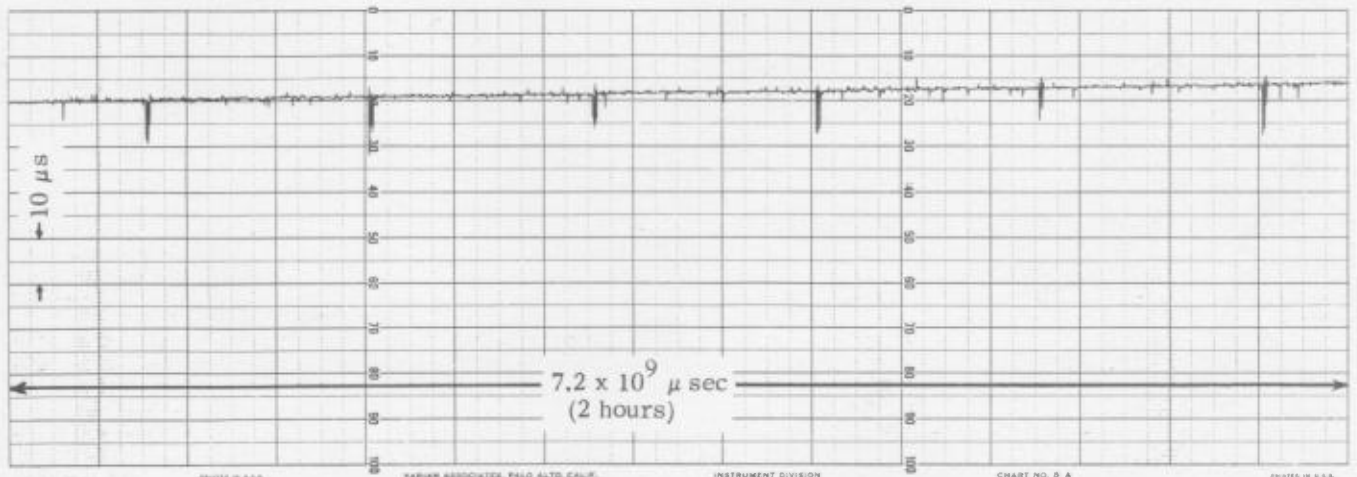

Figure 4. Strip-Chart Recording of VLF Frequency Comparison Using WWVL over one hour period

standard will be a large factor in determining how frequently calibration measurements should be made and to what accuracy the absolute value of the frequency can be set.

2) NBA. This U.S. Navy VLF station transmits on a carrier of 18 KC from Panama. The carrier of NBA is keyed at a one pps repetition rate with a 30% duty cycle. That is, the carrier is on for 0.3 second and off for 0.7 second.

Frequency comparison measurements in this case can be made only during the "on" time of the carrier. This is accomplished in the following way. The equipment setup is the same as that for comparison measurements with WWVL except that the one second tick from the I13AR is used as the start signal to the time interval meter instead of a 1 KC signal. In either case, of course, the start signal is derived from the local standard to be calibrated.

So that comparison can be made to a given point on the vlf carrier, the pulse from the clock is positioned by the phase shifter on the clock panel to occur in the middle or late portion of the received vlf pulse.⁵ The clock pulse is then used to start a time interval measurement on the time interval meter. The measurement will be stopped by the point on the next cycle of the vlf carrier which corresponds to the trigger level and slope setting of the stop channel controls on the time interval meter.

⁵In this way, any variations during the early part of the vlf carrier pulse will not affect the character of the carrier cycle used to stop the time interval meter.

In this case, time interval readings can only be made at a one-per-second rate. The reading rate when comparison is made to a cw station such as WWVL is limited only by the printer speed which, in the case of the Model 560A, is 5 per second.

Calculation of the frequency error of the local standard can be made as described previously and is based upon the time drift of the average time interval readings.

III VLF FOR TIME COMPARISON MEASUREMENTS

As previously discussed, vlf transmissions are more dependable as a long range broadcast means than high frequency radio waves. On the other hand, information bandwidth characteristics have limited, to some extent, the use of vlf for time-of-day information and for time comparison measurements. Rise time of carrier pulses such as those broadcast by NBA are degraded by the time constants of the antenna system and the receiving equipment. Some shaping occurs at the transmitting end as well. This makes time comparisons somewhat more difficult than similar measurements using hf transmissions where rise time is a minor problem and time pulses may be closely resolved.

Research is being done which should result in improvements in the presentation of time information on vlf standard broadcasts. Also, work is being done in the industry to develop vlf receiving equipment which will improve the ability to synchronize accurately from vlf time signals.

12/15/60

3/1/61