



Aug 15, 65

APPLICATIONS OF THE  MODEL 218A,
A VERSATILE GENERAL-PURPOSE PULSE AND DELAY GENERATOR

The  Model 218A, produced initially to meet requirements for generation of precise digital delays, has since proven to offer many advantages as a general purpose laboratory pulse generator. By using the appropriate plug-in unit, a 218A can often take the place of several special-purpose pulse generators.

Here are the "instruments" which the 218A can be:

- 1) Precision dual time interval generator, digitally calibrated from 1 to 10,000 microseconds, with synchronized time marker outputs preset to accuracy of ± 0.1 microsecond, $\pm 0.001\%$.

NOTE: A special version of the 218A is available modified to provide time intervals up to 40,000 microseconds. Longer time intervals can also be generated with the standard 218A by using an external counted frequency.

- 2) Doubler pulser, with amplitude, width, polarity and position of each pulse individually adjustable. Complex pulses (one pulse superimposed on the other) can be obtained.
- 3) Single pulser, providing simultaneous, adjustable amplitude positive and negative pulses, with pulse position and pulse width variable over the complete time range of 1 to 10,000 microseconds.
- 4) Square wave generator with repetition rate as low as 10 cps or less.
- 5) A dual preset counter, operating from a common start trigger, with 10^6 count capacity.

Many users have found it more economical and convenient to have a versatile 218A in the laboratory than to have the several other instruments which would otherwise be needed to do similar jobs.

BASIC FEATURES

General

A dual print counter counting the cycles of a 1 mc crystal oscillator which can be turned on at a random time by a start trigger is the basis of the 218A. Print outputs trigger one of three available pulse generator plug-in units to provide the desired output signal. An internal repetition rate generator provides start triggers if desired.

Two independent output trigger pulses are obtained from the 219A plug-in unit. Either trigger can occur at any time within the 1 to 10,000 microsecond range of the 218A.

Two pulses, each with variable amplitude, width, and polarity, are obtained from the 219B plug-in. Start of each pulse can occur at any time within the range of the 218A delay generators. Pulse can be superimposed.

A single dual-polarity pulse with variable amplitude is obtained from the 219C. Start of the pulse is controlled by one of the 218A's presets; end of the pulse is controlled by the other preset. Thus, both the delay and length of the pulse can be varied through the full 1 to 10,000 microsecond range of the 218A.

Easy to Use

All controls of the 218A and plug-ins are grouped and coded for ease of operation. Time of the start trigger to the 218A is designated t_0 , and the generated time delays are designated t_1 and t_2 . Desired delays for t_1 and t_2 are individually preset in 1 microsecond steps with detented front panel controls. Continuously adjustable front panel controls provide interpolation between the 1 microsecond digital steps. All controls can be accurately adjusted before the instrument is placed in operation.

Related control groups and output signal paths are clearly indicated by front panel engraving.

Versatile Triggering

A wide range of start triggers may be used to initiate the operation cycle of the 218A. These are:

- 1) Internal pulse generator - 10 cps to 10 kc (See SPECIAL APPLICATIONS for lower frequencies.)
- 2) External sine wave generator - 10 cps to 10 kc
- 3) External pulse source - 0 to 10 kc (Start triggers need not be periodic.)
- 4) Manual - front panel pushbutton

Low Jitter

Specified jitter of t_0 , t_1 , and t_2 with respect to the start trigger is only .02 microseconds. Actual jitter is normally much less than this maximum specification, and values as low as a few nanoseconds can be obtained. (See SPECIAL APPLICATIONS.)

Time Markers Available

An internal crystal-controlled 1 mc oscillator is started by the external or internal trigger pulse. The 1 mc is available from a front panel connector to provide synchronized 1 microsecond time markers or for other purposes.

Non-Ambiguous Preset Count

The 218A includes a dual preset counter whose normal function is to define the t_1 and t_2 preset time delays. The counter may also be used independently to deliver output pulses upon the accumulation of a total count as set on the digital control dials. When used to count the internal 1 mc frequency, the usual ± 1 count ambiguity associated with gated counters is eliminated because the 1 mc oscillator is started by the same trigger that gates the counters, and only full cycles are counted.

Read Nautical Miles, Yards, Feet, Meters, etc. Directly

When external frequencies are used instead of the internal 1 mc, the frequency can be adjusted so the dials will read directly in standard measuring unit.

Sync Output

Three position switch provides sync pulse corresponding to t_0 , t_1 , or t_2 from front panel connector.

SPECIAL FEATURES AS A PULSE GENERATOR

Characteristics of the 219B Dual Pulse Unit and the 219C Digital Pulse-Duration Unit make the 218A/219A/B/C a versatile, yet simple to use pulse generator. A wide range of single or double pulses can be provided, and complex pulses can be synthesized for special system testing.

High Output Power

219B provides up to 50 volt pulses into an open circuit from a 50-ohm source. 219C provides at least 15 volts peak into open-circuit from 90-ohm source, or at least 90 volts peak into open circuit from 500-ohm source.

Low Internal Impedance

50-ohm output from 219B and 90-ohm output from 219C match connectors and cables commonly used for pulse transmission.

Good Pulse Characteristics

Pulses from 219B have 0.06 microsecond rise time. 219C output pulse has 0.03 microsecond rise time from 90-ohm source.

Adjustable Pulse Repetition Frequency

The internal repetition rate generator is continuously adjustable from 10 cps to 10 kc. Periodic or non-periodic external triggers can be used also. The Pulse repetition frequency can be digitally controlled by adding an external delay line of approximately 10 microseconds from the t_2 output to the external trigger input, and taking the desired output pulse from t_1 .

Maximum Versatility in Pulse Shape and Position

Each of the pulses from the 219B is independently controlled and may be set to any desired amplitude, polarity, width, and time within the specifications of the equipment. The pulses may be superimposed, or either may be leading. Pulses may be taken separately or on a common output line.

OPERATION

Many of the features of the 218A are made possible by a unique circuit design in which accurate digitally set delays are generated by a novel application of presettable counters. Additional circuitry provides interpolation between the 1 microsecond digitally set intervals.

Major circuits in the 218A are shown in figure 1 below.

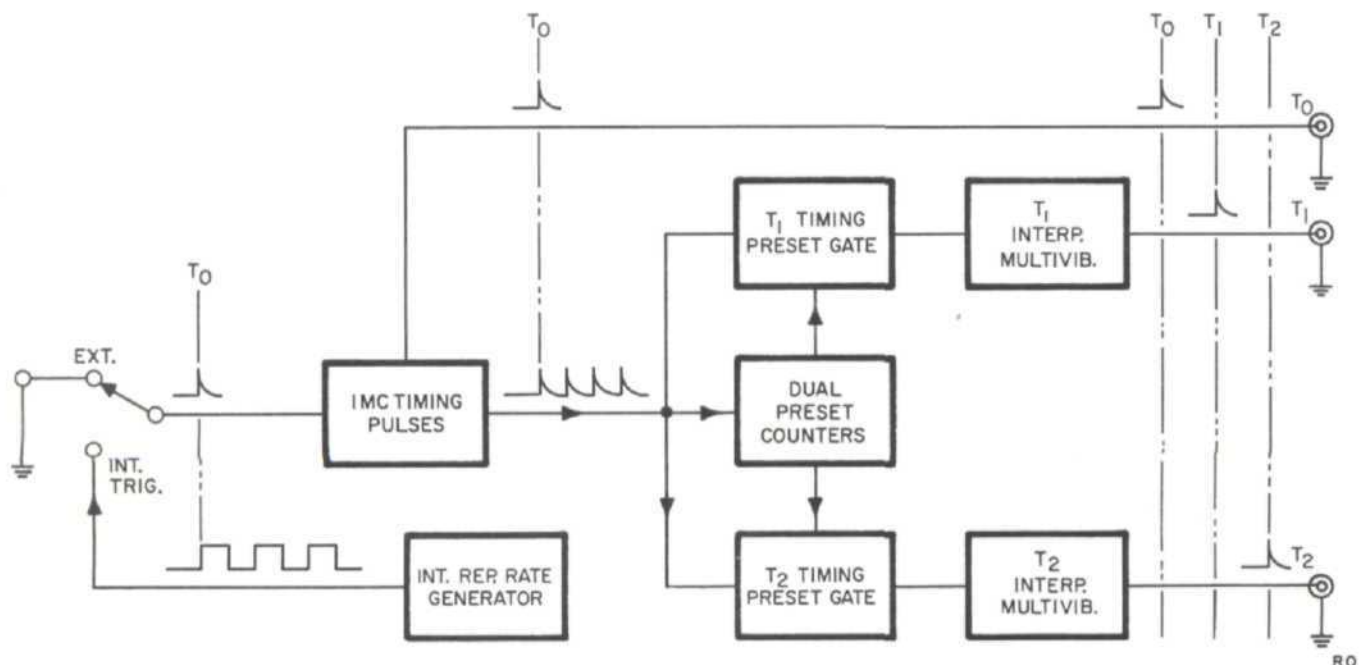

Figure 1. Block Diagram, Model 218A

Digital delays are generated by counting 1 mc timing pulses (or an external frequency) in a dual preset digital counter. Preselected pulses with 1 microsecond spacing controlled by the crystal oscillator, which starts oscillating coherently on command, are thus gated by the preset dials to the interpolation multivibrators which permit adding additional delay of 0 to 1 microsecond.

The start trigger may be obtained from the internal rate generator or from external signals. When the internal 1 mc oscillator is used as the source of timing pulses, the oscillator is gated on by the start trigger. Then, when the counter has totalized the pulses from the oscillator corresponding to the preset delay setting, the preset gate passes a pulse from the oscillator to the interpolation multivibrator. Times t_1 and t_2 correspond to the ends of the interpolation multivibrator cycles. The outputs from the multivibrators control the operation of the 219A, 219B or 219C pulse generator plug-in units. An off time of 70 microseconds or 10% of the longest delay, whichever is longer, is required between the last generated time delay and the start of the next cycle.

NORMAL APPLICATIONS

Pulse Generator

Numerous pulse tests and measurements can be made by using the 219B and 219C pulse generator plug-in units with the 218A. Many different pulse requirements can be synthesized to provide accurately timed gating pulses, step functions, or double pulse trains. Among the applications for which the 218A has been used are:

- 1) Measurement and calibration of pulse code modulation systems.
- 2) Measuring the resolution of gating circuits.
- 3) Determining the ballistic characteristics of a meter movement (by applying an accurately defined pulse from the low impedance output of the 219C).
- 4) Measuring the step function response of mechanical recording systems.
- 5) Measuring the transfer function of a 4-terminal network such as a filter or servo system.
- 6) Sweep delay unit for oscilloscopes.
- 7) Checking radar range units, oscilloscope sweep, and calibration linearity.

Double Pulse Unit

Figure 2 shows how the two pulses provided by the 219B plug-in unit can be programmed.

Pulse A can start at t_0 or t_1 as selected by a front panel switch. Pulse B always starts at t_2 which can be accurately set for any time from 1 to 10,000 microseconds after t_0 . All basic specifications of the 218A for accuracy, jitter, repetition rate, etc., are retained. In addition, amplitude, width, and polarity of each pulse is individually adjustable.

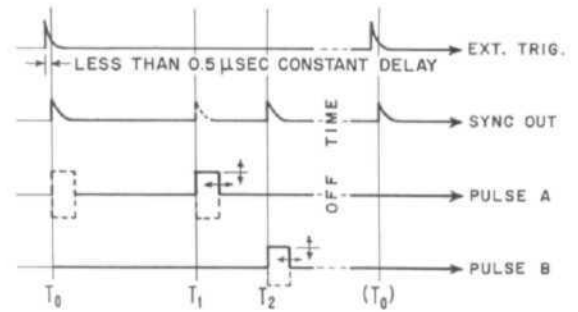

Figure 2. Time Plan, 219B Plug-In Unit

Single Pulse Unit

A single pulse, programmable over extremely wide limits, is available when the 219C Digital Pulse Duration Unit is used with the 218A. The start and stop times of the pulse are digitally controlled by the 218A.

As shown in figure 3, the pulse can start at t_0 and end at t_1 , or start at t_1 and end at t_2 . Thus start time and pulse duration are digitally programmable over the 1 to 10,000 microsecond range of the 218A.

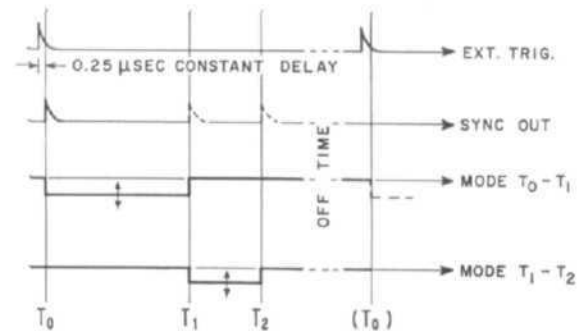

Figure 3. Time Plan, 219C Plug-In Unit

There are two sets of output jacks for the 219C. To provide simultaneous positive- and negative-going pulses. The 90-ohm output is adjustable from 0 to at least 15 volts peak into an open circuit. The 500-ohm output provides a fixed amplitude, minimum 90-volt peak pulse into an open circuit. Positive excursion of each pulse clamps to ground.

Dual Trigger Unit

Many calibration and measurement jobs requiring accurate time markers can conveniently be done with the 219A Dual Trigger Plug-In Unit and the 218A.

Measuring Pulse Characteristics

Rise time, pulse width, and other pulse characteristics can be determined as shown in figure 4 using accurately timed output pulses of the 219A to modulate the oscilloscope presentation of the unknown pulse. Position of the timing pulses from the 219C

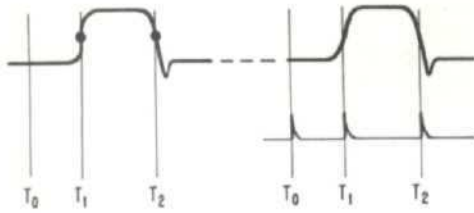

Figure 4. Measuring Waveforms

is easily changed by turning the time delay dials of the 218A. Sweep time of the oscilloscope used need not be calibrated since the time reading is taken directly from the 218A.

Measuring and Calibrating Delay Lines

Figure 5 shows a typical instrument arrangement for checking delay lines with the 219B double pulse unit. Output pulse A at time t_0 is fed to the input of the delay line whose output is connected to one of the vertical inputs of a dual channel oscilloscope. Output pulse B at time t_2 is then applied to the other vertical input and used as a variable time marker. Thus, the delay of the line can be read directly from the time delay dials of t_2 on the 218A.

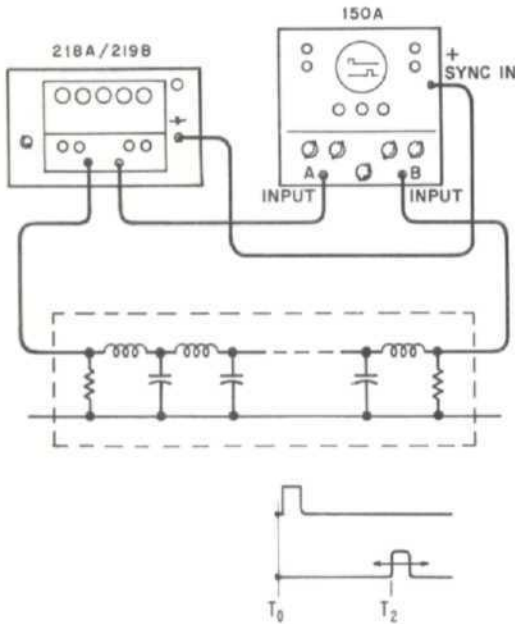

Figure 5. Measuring Time Delays

Calibrating Oscilloscope Sweep Time and Linearity

The accurate time measuring capability of the 218A/219A combination is useful for checking the sweep circuits of an oscilloscope. By synchronizing the oscilloscope at t_0 (with the synchronizing pulse output from the 218A), markers are available at t_1 and t_2 for checking sweep time and linearity. Figure 6a shows how the total sweep time can be determined

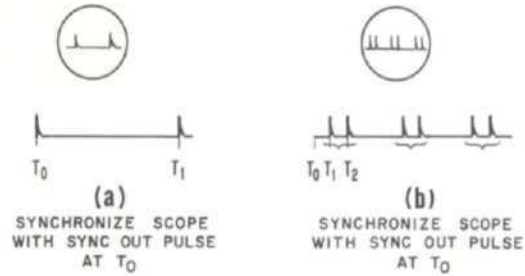

Figure 6. Sweep Calibration

by adjusting the t_1 pulse to appear at the end of the trace; sweep time is read from the t_1 dials on the 218A.

Figure 6b shows how sweep linearity can be checked by using pulses at t_1 and t_2 to measure short sweep time intervals at various points across the sweep. For extremely fast sweeps, 1 microsecond time markers can be obtained from the 1 mc crystal oscillator in the 218A. Since the oscillator is started at t_0 , the timing markers will be in exact relationship to the start of the sweep.

Radar System Calibration

Accurate control of pulse start time facilitates calibration of various types of radar systems as shown in figure 7. The radar scope is synchronized with the sync pulse from the 218A at t_0 . Then, for Type B and PPI presentations, precision time markers from the 219A Dual Trigger Unit intensity modulate the scope trace. For Type A presentation the single pulse output of the 219C Plug-In Unit can also be used. The low output impedance of the plug-in pulse generators provides precisely defined rf pulses at t_0 , t_1 or t_2 ; they can be used for checking gain, bandwidth and other system characteristics.

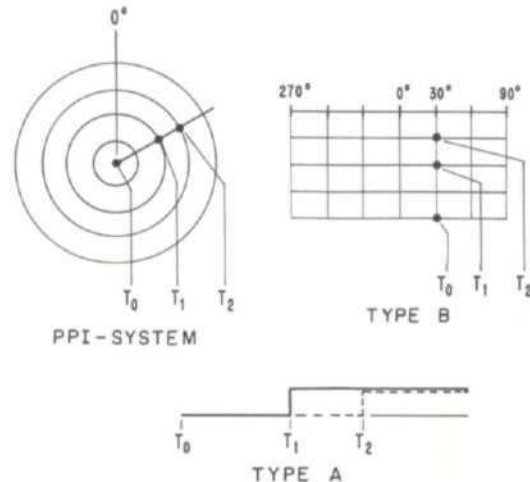

Figure 7. Radar System Calibration

Measuring Jitter

Because the 218A can deliver a pulse at a precisely determined time after occurrence of a random external trigger, the instrument provides an excellent method for measuring jitter (slight random variation) in a periodic signal. The 218A is triggered externally by the signal whose jitter is to be measured. The oscilloscope is synchronized with t_1 which is set to be slightly lower than the period of the signal to be measured. With a fast sweep on the scope, a presentation as shown in figure 8 will be obtained, and the amount of jitter can be determined.

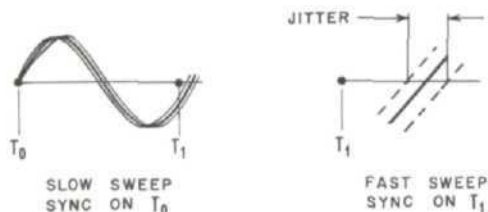

Figure 8. Jitter Measurement

SPECIAL APPLICATIONS

In several applications, minor modifications have been made to the 218A to even further increase the instrument's versatility.

Increasing Available Delay to 40,000 Microseconds in 1 Microsecond Steps

The top plug-in unit of the 218A can be provided with a factory modification to provide 1 to 40,000 microsecond delay in one microsecond digital steps with continuous interpolation between steps. Several circuit changes are made within the plug-in unit, and an additional set of concentric delay dials is added to the front panel. All other specifications remain the same, and the operation of the plug-in units is not affected. Your representative can obtain price and delivery information on this special modification for you.

Lower Repetition Rates from Internal Rate Generator

The RC network used to control the repetition rate of the internal trigger generator can be modified easily to provide repetition rates lower than 10 cps. The network consists of R113 and associated calibrating resistors together with C106, C107, or C108, depending on the range. The circuit is arranged so $F = 0,4RC$.

The repetition rate can be lowered by using a larger capacitor connected across the existing capacitors on S101, or from pin 7 to pin 8 on J103. (A single capacitor connected across J103 will lower the frequency of all ranges.)

A low leakage mylar, oil or paper 300-volt, dc capacitor should be used. By changing only the capacitor, the dial spread of the rate generator will remain at 10:1. Total capacity of $1.8 \mu f$ should be used for a range of 1 cps to 10 cps; or $18 \mu f$ may be used to provide a range of 0.1 to 1 cps.

Using the 218A as a Gated Class A Amplifier for Pulse Bursts or Frequency Shift Keying

Figure 9 shows how the 218A/219C can be used with the 152A/B plug-in of the Model 150A Oscilloscope to obtain digitally controlled pulse bursts. The 152A/B is used in the chopped mode with the chopping circuit driven by the 219C Digital Pulse Duration Unit. Keying and output leads are brought out from the 152A/B as shown, and the desired sine wave inputs are applied to the normal input jacks. The 152A/B is left in the 150A Oscilloscope which then serves only as a power supply. Similar connections can be made to other dual trace oscilloscope plug-in units.

With this arrangement, the input attenuators, polarity switches, and amplitude controls of all units operate in a normal fashion. The centering controls of the 152A/B adjust dc shift in the output.

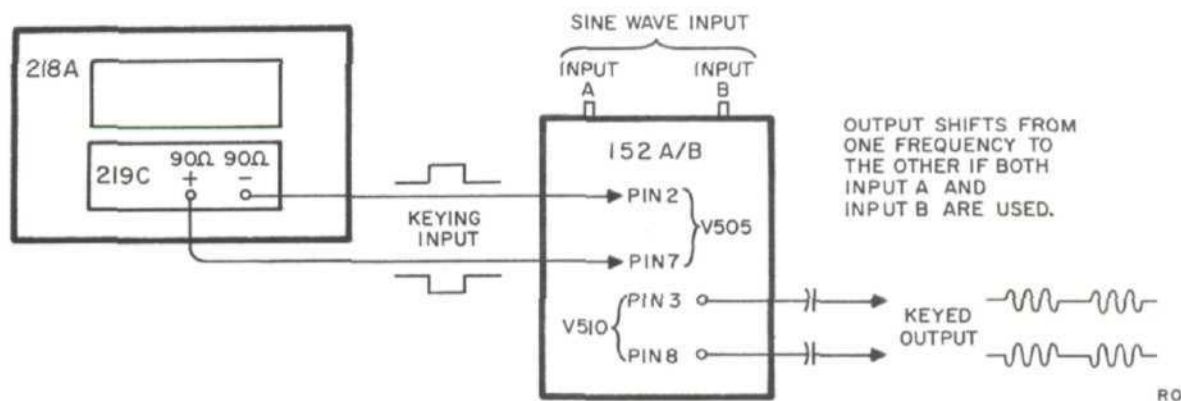

Figure 9. Using the 218A/219C with the 152A/B Oscilloscope Plug-In to Provide Pulse Bursts or Frequency Shift Keying

Operation for Minimum Jitter

The .02 microsecond jitter specification for the 218A is a conservative maximum value. Measurements made in the laboratory on several different units showed that if sufficient off time between cycles is allowed, jitter of 3 nanoseconds or less is typical.

The off time between preceding t_0 allows energy stored in the internal 1 mc crystal to be dissipated.

If this energy is not completely dissipated, the crystal oscillator is not free to start at a completely random time.

Other features disclosed by detailed laboratory testing were that the jitter of t_0 with respect to the external start pulse is less than 1 nanosecond, and that jitter between t_1 and t_2 is of the order of 1 nanosecond. Jitter is not affected by choice of internal rate generator or external trigger.

The 219B as a Triple Pulse Generator

The modification to the 219B shown in figure 10 (the 218AR is standard) makes it compatible with ARINC SPECIFICATION 532 for testing ATC airborne transponders (which use, for example, the Boonton 8925A DME/ATC TEST SET). This triple pulse output is used to check the side lobe rejection circuits of the transponder.

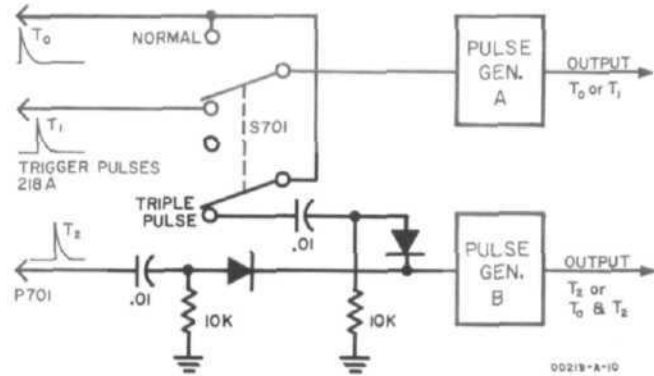

Figure 10. Triple Pulse Generator

HP SALES AND SERVICE OFFICES IN THE U.S. AND CANADA

ALABAMA

Huntsville, 35801
Hewlett-Packard
Southern Sales Division
Holiday Office Ctr., Suite 18
(205) 881-4591
TWX: 510-579-2204

ARIZONA

Scottsdale, 85251
Hewlett-Packard
Neely Sales Division
3009 No. Scottsdale Rd.
(602) 945-7601
TWX: 602-949-0111

Tucson, 85716
Hewlett-Packard
Neely Sales Division
232 So. Tucson Blvd.
(602) 623-2564
TWX: 602-792-2759

CALIFORNIA

Los Angeles Area
Hewlett-Packard
Neely Sales Division
3939 Lankershim Blvd.
North Hollywood 91604
(213) 877-1282 and 766-3811
TWX: 910-499-2170

Sacramento, 95821
Hewlett-Packard
Neely Sales Division
2591 Carlsbad Ave.
(916) 482-1463
TWX: 916-444-8683

San Diego, 92106
Hewlett-Packard
Neely Sales Division
1055 Shafter Street
(714) 223-8103
TWX: 714-276-4263

San Francisco Area
Hewlett-Packard
Neely Sales Division
1101 Embarcadero Rd.
Palo Alto 94303
(415) 327-6500
TWX: 910-373-1280

COLORADO

Englewood, 80110
Hewlett-Packard
Neely Sales Division
7965 East Prentice
(303) 771-3455
TWX: 303-771-3056

CONNECTICUT

Middletown, 06458
Hewlett-Packard
Yewell Sales Division
589 Saybrook Rd.
(203) 346-6611
TWX: 710-428-2036

FLORIDA

Miami, 33125
Hewlett-Packard
Florida Sales Division
2907 Northwest 7th St.
(305) 635-6461

Orlando, 32803
Hewlett-Packard
Florida Sales Division
621 Commonwealth Ave.
(305) 425-5541
TWX: 305-275-1234

St. Petersburg, 33708
Hewlett-Packard
Florida Sales Division
410-150th Ave., Madeira Beach
(813) 391-0211
TWX: 813-391-0666

GEORGIA

Atlanta, 30305
Hewlett-Packard
Southern Sales Division
3110 Maple Drive, N. E.
(404) 233-1141
TWX: 810-751-3283

ILLINOIS

Chicago, 60645
Hewlett-Packard
Crossley Sales Division
2501 West Peterson Ave.
(312) 275-1600
TWX: 910-221-0277

INDIANA

Indianapolis, 46205
Hewlett-Packard
Crossley Sales Division
3919 Meadows Dr.
(317) 546-4891
TWX: 317-635-4300

KENTUCKY

Louisville, 40218
Hewlett-Packard
Southern Sales Division
Suite 4, 3411 Bardstown Rd.
(502) 459-4140
TWX: 810-535-3128

MARYLAND

Baltimore, 21207
Hewlett-Packard
Horman Sales Division
6660 Security Blvd.
(301) 944-5400

Washington, D. C. Area
Hewlett-Packard
Horman Sales Division
941 Rollins Avenue
Rockville 20852
(301) 427-7560
TWX: 710-828-9684

MASSACHUSETTS

Boston Area
Hewlett-Packard
Yewell Sales Division
Middlesex Turnpike
Burlington 01804
(617) 272-9000
TWX: 710-332-0382

MICHIGAN

Detroit, 48235
Hewlett-Packard
Crossley Sales Division
14425 West Eight Mile Road
(313) 342-5700
TWX: 313-342-0702

MINNESOTA

St. Paul, 55114
Hewlett-Packard
Crossley Sales Division
842 Raymond Avenue
(612) 646-7881
TWX: 910-563-3734

MISSOURI

Kansas City, 64131
Harris-Hanson Company
7916 Paseo Street
(816) 444-9494
TWX: 816-556-2423

St. Louis, 63144
Harris-Hanson Company
2814 South Brentwood Blvd.
(314) 647-4350
TWX: 314-962-3933

NEW JERSEY

Asbury Park Area
Hewlett-Packard
Robinson Sales Division
Shrewsbury
(201) 747-1060

Englewood, 07631

Hewlett-Packard
RMC Sales Division
391 Grand Avenue
(201) 567-3933

NEW MEXICO

Albuquerque, 87108

Hewlett-Packard
Neely Sales Division
6501 Lomas Blvd., N. E.
(505) 255-5586
TWX: 910-989-1665

Las Cruces, 88001

Hewlett-Packard
Neely Sales Division
114 S. Water Street
(505) 526-2486
TWX: 505-524-2671

NEW YORK

New York, 10021

Hewlett-Packard
RMC Sales Division
236 East 75th Street
(212) 879-2023
TWX: 710-581-4376

Rochester, 14625

Hewlett-Packard
Syracuse Sales Division
800 Linden Avenue
(716) 381-4120
TWX: 716-221-1514

Poughkeepsie, 12601

Hewlett-Packard
Syracuse Sales Division
82 Washington St.
(914) 454-7330
TWX: 914-452-7425

Syracuse, 13211

Hewlett-Packard
Syracuse Sales Division
5858 East Molloy Rd.
(315) 454-2486
TWX: 710-541-0482

NORTH CAROLINA

High Point, 27262

Hewlett-Packard
Southern Sales Division
1923 N. Main Street
(919) 882-6873
TWX: 510-926-1516

OHIO

Cleveland, 44129

Hewlett-Packard
Crossley Sales Division
5579 Pearl Road
(216) 884-9209
TWX: 216-888-0715

Dayton, 45409

Hewlett-Packard
Crossley Sales Division
1250 W. Dorothy Lane
(513) 299-3594
TWX: 513-944-0090

PENNSYLVANIA

Camp Hill

Hewlett-Packard
Robinson Sales Division
(717) 737-6791

Philadelphia Area

Hewlett-Packard
Robinson Sales Division
144 Elizabeth Street
West Conshohocken 19428
(215) 248-1600 and 828-6200
TWX: 215-828-3847

Pittsburgh Area

Hewlett-Packard
Crossley Sales Division
2545 Moss Side Blvd.
Monroeville 15146
(412) 271-5227
TWX: 710-797-3650

TEXAS

Dallas, 75209

Hewlett-Packard
Southwest Sales Division
P.O. Box 7166, 3605 Inwood Rd.
(214) 357-1881 and 332-6667
TWX: 910-861-4081

Houston, 77027

Hewlett-Packard
Southwest Sales Division
P.O. Box 22813, 4242 Richmond Ave.
(713) 667-2407
TWX: 713-571-1353

UTAH

Salt Lake City, 84115

Hewlett-Packard
Neely Sales Division
1482 Major St.
(801) 486-8166
TWX: 801-521-2604

VIRGINIA

Richmond, 23230

Hewlett-Packard
Southern Sales Division
2112 Spencer Road
(703) 282-5451
TWX: 710-956-0157

WASHINGTON

Seattle Area

Hewlett-Packard
Neely Sales Division
11656 N. E. 8th St.
Bellevue 98004
(206) 454-3971
TWX: 910-443-2303

CANADA

Montreal, Quebec
Hewlett-Packard (Canada) Ltd.
8270 Mayrand Street
(514) 735-2273
TWX: 610-421-3484

Ottawa, Ontario

Hewlett-Packard (Canada) Ltd.
1762 Carling Avenue
(613) 722-4223
TWX: 610-562-1952

Toronto, Ontario

Hewlett-Packard (Canada) Ltd.
1415 Lawrence Avenue West
(416) 249-9196
TWX: 610-492-2382

GOVERNMENT CONTRACTING OFFICES

Middletown, Pa. 17057

Hewlett-Packard
Contract Marketing Division
Olmsted Plaza
(717) 944-7401
TWX: 717-760-4816

West Conshohocken, Pa. 19428

Hewlett-Packard
Contract Marketing Division
144 Elizabeth St.
(215) 753-1811
TWX: 215-820-3847

HP INTERNATIONAL SALES AND SERVICE OFFICES

ARGENTINA

Mauricio A. Saurez
Telecomunicaciones
Carlos Calvo 224, Buenos Aires
Tel: 30-6312

AUSTRALIA

Sample Electronics (Vic.) Pty. Ltd.
9-11 Cremorne Street
Richmond E. 1, Victoria
Tel: 42-4757 (3 lines)

Sample Electronics (N.S.W.) Pty. Ltd.
4 Grose Street, Glebe, N.S.W.
Tel: 69-6338 (6 lines)

AUSTRIA

UNILABOR H.m.b.H.
Wissenschaftliche Instrumente
Rummelhardtgasse 6 3
P.O. Box 33, Vienna IX 71
Tel: 42 61 81

BELGIUM

Hewlett-Packard Benelux
20-24 Rue de l'Hopital, Brussels 1
Tel: 11.22.20

BRAZIL

CIENTAL IMPORTACAO E COMERCIO LTDA
R. Cons. Crispiniano, 69, 8. = Conj. 81
Sao Paulo, S.P.
Tel: 32-4332

CANADA

Hewlett-Packard (Canada) Ltd.
8270 Mayrand Street
Montreal, Quebec
(514) 735-2273

Hewlett-Packard (Canada) Ltd.
1762 Carling Avenue
Ottawa, Ontario
(613) 722-4223

Hewlett-Packard (Canada) Ltd.
1415 Lawrence Avenue W.
Toronto, Ontario
(416) 249-9196

CHILE

Hector Calcagni
Casilla 13942, Santiago
Tel: 6.42.26

DENMARK

Tage Olsen A. S.
Rønnegade 1, Copenhagen Ø
Tel: 29.48.00

FINLAND

INTO O.Y.
P. O. Box 153
11 Meritullinkatu, Helsinki
Tel: 6.11.33

FRANCE

Hewlett-Packard France
150 Blvd. Massena, Paris 13e
Tel: 707.97.19

GERMANY

Hewlett-Packard V.m.b.H.
Steindamm 35, Hamburg
Tel: 24.05.51

Hewlett-Packard V.m.b.H.
Kurfürstenstrasse 95
6 Frankfurt am Main
Tel: 52.00.36

Hewlett-Packard V.m.b.H.
Reginfriedstrasse 13
8 Munich 9
Tel: 49.51.21.22

Hewlett-Packard V.m.b.H.
Technisches Büro
Herrenbergerstrasse 110
703 Böblingen, Württemberg
Tel: 6971

GREECE

K. Karayannis
Klaffmonos Square, Athens 124
Tel: 230.301 (5 lines)

INDIA

The Scientific Instrument Company, Ld.
6, Tej Bahadur Sapru Road, Allahabad 1
Tel: 2451

The Scientific Instrument Company, Ld.
240, Dr. Dadabhai Naoroji Rd., Bombay 1
Tel: 26-2642

The Scientific Instrument Company, Ld.
11, Esplanade East, Calcutta 1
Tel: 23-4129

The Scientific Instrument Company, Ld.
30, Mount Road, Madras 2
Tel: 86339

The Scientific Instrument Company, Ld.
B-7, Ajmeri Gate Extn., New Delhi 1
Tel: 271053

IRAN

Telecom Ltd.
P. O. Box 1812, Tehran
Tel: 43850

ISRAEL

Electronics & Engineering Ltd.
16 Kremenetski St., Tel Aviv
Tel: 35021-2-3

ITALY

Hewlett-Packard Italiana S.p.A.
Viale Lunigiana 46, Milan
Tel: 69.15.84 5 6

Hewlett-Packard Italiana S.p.A.
Palazzo Italia
Piazza Marconi, 25, Roma-Eur
Tel: 59.12.544 5

JAPAN

Yokogawa-Hewlett-Packard Ltd.
2270 Ishikawa-cho
Hachioji, Tokyo
Tel: Hachioji 0426-3-1231 (19 lines)

Yokogawa-Hewlett-Packard Ltd.
No. 3, 6-chome, Aoyama-Kitamachi
Akasaka, Minato-ku, Tokyo
Tel: 403-0073, 403-0074, 403-0075

Yokogawa-Hewlett-Packard Ltd.
No. 8, Umeda, Kita-ku, Osaka City
Tel: 361-3084, 341-2095

Yokogawa-Hewlett-Packard Ltd.
No. 4, 3-chome, Himeikedori,
Chigusa-ku, Nagoya City
Tel: 75-8545

KOREA

American Trading Company, Korea, Ltd.
112-35 Sokong-Dong, Jung-ku
Seoul P. O. Box 1103, Seoul
Tel: 3-7049, 3-7613

NETHERLANDS

Hewlett-Packard Benelux N.V.
23 Burg Roellstraat, Amsterdam W.
Tel: (020) 13.28.98 and 13.54.99

NEW ZEALAND

Sample Electronics (N. Z.) Ltd.
8 Matipo Street
Onehunga S. E. 5, Auckland
Tel: 565-361

NORWAY

Morgenstjerne & Co. A/S
Ingeniørfirma
6 Wessels Gate, Oslo
Tel: 20 16 35

PORTUGAL

TELECTRA
Rua Rodrigo da Fonseca 103
P. O. Box 2531, Lisbon 1
Tel: 68 60 72 and 68 60 73 and 68 60 74

PUERTO RICO & VIRGIN ISLANDS

San Juan Electronics, Inc.
150 Ponce de Leon, Stop 3
P. O. Box 5167
Pta. de Tierra Sta., San Juan 00906
Tel: 722-3342, 724-4406

SPAIN

ATAIO, Ingenieros
Enrique Larreta 12, Madrid 6
Tel: 235.43.44 and 235.43.45

SOUTH AFRICA

F. H. Flanter & Co. (Pty.), Ltd.
Rosella House
Buitencingle Street, Cape Town
Tel: 3-3817

SWEDEN

H-P Instrument AB
Centralvägen 28, Solna, Centrum
Tel: 08-83.08.30 and 10-83.08.30

SWITZERLAND

Max Paul Frey
Wankdorffeldstrasse 66, Berne
Tel: (031) 42.00.78

TAIWAN (FORMOSA)

Hwa Sheng Electronic Co., Ltd.
21 Nanking West Road, Taipei
Tel: 4 6076, 4 5936

TURKEY

TELEKOM Engineering Bureau
P.O. Box 376—Galata, Istanbul
Tel: 49.40.40

UNITED KINGDOM

Hewlett-Packard Ltd.
Dallas Rd., Bedford, England
Tel: Bedford 68052

VENEZUELA

Citec, C. A.
Edif. Arisañ-Of #4
Avda. Francisco de Miranda-Chacaito
Apartado del Este 10.837, Caracas
Tel: 71.88.05

YUGOSLAVIA

Belram S.A.
83 Avenue des Mimosas
Brussels 15, Belgium
Tel: 35.29.58

For Sales and Service Assistance in Areas Not Listed Contact:

IN EUROPE

Hewlett-Packard, S. A.
54 Route des Acacias
Geneva, Switzerland
Telephone: (022) 42.81.50
Telex: 2.24.86
Cable: HEWPACKSA

IN LATIN AMERICA

Hewlett-Packard Inter-Americas
1501 Page Mill Road
Palo Alto, California 94304, U.S.A.
Telephone: (415) 326-7000
TWX: 910-373-1267
Telex: 033811 Cable: HEWPACK

ELSEWHERE

Hewlett-Packard
International Marketing Department
1501 Page Mill Road
Palo Alto, California 94304, U.S.A.
Telephone: (415) 326-7000
TWX: 910-373-1267
Telex: 033811 Cable: HEWPACK