

HEWLETT-PACKARD

MICROWAVE MEASUREMENTS FOR CALIBRATION LABORATORIES

APPLICATION NOTE 38



APPLICATION NOTE 38

MICROWAVE MEASUREMENTS
FOR
CALIBRATION LABORATORIES

WLOG

CONTENTS

SECTION I	INTRODUCTION	Page
	1 - 1 General Description	I - 1
	1 - 2 NBS Calibration	I - 3
	1 - 3 General Techniques	I - 3
SECTION II	FREQUENCY	
	2 - 1 General Description	II - 1
	2 - 2 Frequency Measurements between 0 and 220 Megacycles	II - 2
	2 - 3 Frequency Measurements between 220 Megacycles and 12.4 KMC	II - 6
	2 - 4 Frequency Measurements of Passive Elements	II - 12
	2 - 5 Time Comparisons	II - 18
	2 - 6 References	II - 21
SECTION III	ATTENUATION	
	3 - 1 General Description	III - 1
	3 - 2 Attenuation Measurements with Square-Law Detection	III - 3
	3 - 3 Attenuation Measurements with Linear Detection	III - 10
	3 - 4 References	III - 14
SECTION IV	IMPEDANCE	
	4 - 1 General Description	IV - 1
	4 - 2 Impedance Measurements with the 803A VHF Bridge (50 to 500 MC)	IV - 1
	4 - 3 SWR Measurements with the Slotted Line	IV - 5
	4 - 4 SWR Measurement of Transmission Systems by the Sliding-Load Technique	IV - 11
	4 - 5 Impedance Measurement	IV - 13
	4 - 6 Null-Shift Technique for Residual-Reflection and Impedance Measurement Corrections	IV - 15
	4 - 7 Directional Coupler Measurements	IV - 22
	4 - 8 Reflection-Coefficient Measurements with Reflectometer Systems	IV - 25
	4 - 9 References	IV - 28
SECTION V	POWER	
	5 - 1 General Description	V - 1
	5 - 2 Power Measurements with the 430C Power Meter	V - 3
	5 - 3 Power Measurements with the K04 999A Bolometer Bridge	V - 6
	5 - 4 Power Measurements with the 434A Calorimetric Power Meter	V - 10
	5 - 5 References	V - 13
ADDENDA	ADDENDUM A	
	Bolometer Mount Efficiency Measurement	A - 1

ADDENDUM B

Page

Operating Notes -hp- Model K04 999C Line Length Set	B - 1
1. Directivity	B - 1
2. Error Signals in Directional Couplers	B - 2
3. Theory of Operation	B - 2
4. Operation	B - 3
5. Phase Considerations	

ADDENDUM C

Application Note #3 - Measurement of the Carrier Frequency of RF Pulses	C - 1
--	-------

ADDENDUM D

Analysis of Microwave Measurement Techniques by means of Signal Flowgraphs.	D - 1
--	-------

SECTION I INTRODUCTION

1-1 GENERAL DESCRIPTION

The age of missiles, rockets, and supersonic aircraft has prompted many advances in electronics. In the design of these products manufacturers are asking the electronics industry for advanced electronic equipment. They want equipment that will perform more functions, offer greater reliability, have greater accuracy, and occupy only half as much space as previous equipment.

One of the most stringent requirements is higher accuracy. With aircraft traveling faster, the job of seeking out the craft and displaying its position requires accuracies far greater than previously needed. A slight error in control of a space-probing rocket

might cause it to miss the proposed target by thousands of miles. Since electronics plays the predominant role in these flight systems, the provision of higher accuracy has become vital to the electronics industry.

The need for higher accuracy of measurement and for compatible, more reliable components has promoted an increasing emphasis on standards laboratories. The military has made great strides in the standards program. For example, the Air Force is establishing laboratories at each base. Also, industrial organizations are establishing laboratories and utilizing the services provided by the National Bureau of Standards.

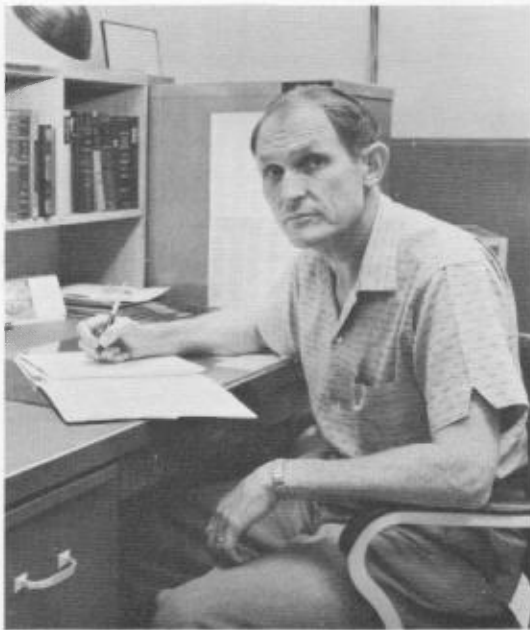

Phil Hand, head of the -hp- Standards Department, has been with the company since 1947. He holds a B. S. degree from Santa Clara, an M. S. from Stanford, and is an expert in the standards field.



Ted Thomsen, a development engineer with the -hp- Standards Department, is shown checking the calibration of a 393A Variable Attenuator at one of the microwave test benches.

TABLE 1-1. NBS SERVICES IN THE MICROWAVE REGION

ITEM	TRANSMISSION LINE	FREQUENCY RANGE	CALIBRATION RANGE	CALIBRATION ACCURACY *
ATTENUATION				
Attenuator Directional coupler	3/8" Coax Type N connector	300 to 5600 mc	0 to 40 db	0.2 db or 1%, which- ever is greater. Variable attenuators: 0.1 db or 1%, which- ever is greater. Fixed pads and dir. couplers: 0.2 db or 1%, which- ever is greater.
	RG-48/U (WR 284)	2.60 to 3.95 kmc		
	RG-49/U (WR 187)	3.95 to 5.85 kmc		
	RG-50/U (WR 137)	5.85 to 8.20 kmc	0 to 70 db	
	RG-51/U (WR 112)	7.05 to 10.00 kmc		
	RG-52/U (WR 90)	8.20 to 12.40 kmc		
	RG-91/U	12.4 to 18.0 kmc		
FREQUENCY				
Frequency meter (cavity)	3/8" Coax Type N connector	300 to 4000 mc		Limited by dial re- settability
	RG-48/U (WR 284)	2.60 to 3.95 kmc		
	RG-49/U (WR 187)	3.95 to 5.85 kmc		
	RG-50/U (WR 137)	5.85 to 8.20 kmc		
	RG-51/U (WR 112)	7.05 to 10.00 kmc		
	RG-52/U (WR 90)	8.20 to 12.40 kmc		
	RG-91/U (WR 62)	12.40 to 18.00 kmc		
	RG-66/U (WR 42)	18.00 to 26.50 kmc		
	RG-96/U (WR 28)	26.50 to 40.00 kmc		
	RG-97/U (WR 22)	33.0 to 50.0 kmc		
	RG-98/U (WR 15)	50.0 to 75.0 kmc		
POWER				
Bolometer mount	RG-52/U (WR 90)	8.20 to 12.40 kmc	1 to 10 mw	1%
	RG-48/U (WR 284)	2.60 to 3.95 kmc		
	3/8" Coax Type N connector	300 to 4000 mc		
IMPEDANCE				
Standard mismatch	RG-52/U (WR 90)	8.20 to 12.40 kmc	VSWR 1.01-1.5	

* The NBS Certificate (or Report) usually gives values to a higher precision than the certified accuracy. This practice is helpful in studying the effects of time, frequency, and other influences.

Hewlett-Packard, recognizing the need for standards laboratories, has helped the military and industry with their standards programs. An -hp- publication, Application Note 21, shows equipment setups for microwave standards measurements utilizing commercially available equipment. This Application Note was written to supplement Application Note 21 and provides a thorough discussion of microwave measurements. A companion Application Note called "Standards Calibrations Procedures" shows detailed calibration instructions for some of the Hewlett-Packard instruments commonly found in standards laboratories.

In standards measurements, accuracy is of primary importance. Special techniques are required in the microwave region since the obtained accuracy is chiefly determined by the measurement technique. This Application Note explains measurement definitions, theory, and sources of error, and provides techniques developed at the -hp- Standards Laboratory for accurate measurements. Sections II through V discuss measurements of frequency, attenuation, impedance, and power. They present complete information for making these measurements. Addenda are also included with detailed information on specific subjects.

1-2 NBS CALIBRATION

The National Bureau of Standards provides calibrations of such devices as attenuators and bolometers for laboratories and other research groups. The Hewlett-Packard Standards Laboratory frequently consults with NBS and submits various instruments for calibration. NBS does not approve standards; instead, it issues certificates or test reports. Instrument certificates are issued when NBS believes that a standard will retain the certified accuracy over a reasonable period of time. Test reports may be issued when there is not a sufficient history of stability to justify certification or for instruments that contain active elements. Table 1-1 shows the services NBS currently provides in the microwave region. A complete schedule of NBS services may

be obtained by writing to the Government Printing Office for NBS Report 5589.

1-3 GENERAL TECHNIQUES

The following precautions apply to all measurements.

- 1) When an instrument is calibrated, the accuracy of the calibrating system must be greater than that of the instrument under test. In general, in microwave measurements the calibrating system should have an accuracy at least three times better than that of the test instrument. For example, for calibration of the frequency dial of a signal generator having an accuracy of 1%, the calibrating system must have an accuracy of 0.3% or better.
- 2) Carefully align waveguide flanges to prevent mismatch losses. Use clamps or bolts to hold equipment together.
- 3) If improperly used, type N connectors introduce discontinuities into the system. Inspect them often for wear or improper fitting. If necessary, replace them.
- 4) Make all leads as short as possible to eliminate losses and pickup from stray fields.
- 5) When sensitive indicators such as the Hewlett-Packard Model 415B Standing Wave Indicator are used, isolate the green ground wire of the power cord from the common ground using a 3-prong-to-2-prong adapter. When the adapter is used, the ground pin is terminated in a short green lead. Small ground currents in the power-cord ground wire might cause erratic meter readings.
- 6) Operate all equipment within manufacturers' specifications. Instruments such as barretters burn out quickly when subjected to excessive power.
- 7) A crystal detector and an oscilloscope provide a convenient method of monitoring modulated high-frequency sources and thus ensure optimum operation of klystrons.

SECTION II FREQUENCY

2-1 GENERAL DESCRIPTION

FREQUENCY MEASUREMENT

Frequency may be measured by several techniques. During the last decade, however, electronic counters have become especially popular, because of their high accuracy, ease of operation, and simplicity of read-out. The discussion in this section is limited to electronic counters, as they have, in general, made obsolete other methods for simple frequency measurement.

Frequencies are accurately measured using an electronic counter. Either the frequency or the period of the signal may be measured. When the frequency is measured, the electronic counter counts the input signals for a precise interval of time. With the -hp-524 Counters, the gate times during which the frequency is measured may be selected from 0.001 to 10 seconds. The gate times are obtained from a stable, precision oscillator. For high accuracy, the gate times in the 524C/D Electronic Counter are obtained from an oscillator that has a stability of 3 parts in 10^8 short term or 5 parts in 10^8 per week.

For measuring low frequencies, it usually is more accurate to measure the period of the signal. The period is measured by counting a precision frequency obtained from the counter oscillator for one or more cycles of the signal. With the 524 Counters, the counted frequency may be selected from 10 cps to 10 megacycles. The accuracy of the measurement may be increased by taking the average over a number of periods.

The -hp- 524 Counters perform a number of frequency measurements. They may be used alone to measure frequencies up to 10 megacycles. The addition of the 526C Period Multiplier greatly increases their accuracy in the low frequency range. For higher frequencies, plug-ins are available to increase the frequency range to 220 megacycles. The 525A covers the range from 10 megacycles to 100 megacycles, and the 525B covers the range from 100 megacycles to 220 megacycles. The 525 Frequency Converters heterodyne the input signal with a harmonic of 10 megacycles to provide an output frequency within the

range of the 524 Electronic Counters. Hence, the high accuracy of the 524 Counters is preserved.

The 540B Transfer Oscillator used with the 524 Counter extends the range to above 220 megacycles. The 540B contains a 100- to 220-megacycle oscillator which is tuned so that a harmonic of the oscillator frequency beats with the unknown signal. The frequency of the oscillator is measured with the 524 Counter and 525B Frequency Converter. The order of the harmonic is determined and the frequency of the unknown signal calculated. Frequency measurement is discussed more thoroughly in Paragraphs 2-2 and 2-3.

TIME COMPARISON

Frequently in standards work it is necessary to compare a frequency standard with a very precise standard, such as WWV. Heterodyne techniques provide comparison accuracy of about 1 part in 10^7 . This is sufficient for many oscillators. But oscillators having greater stabilities must be standardized on a time basis, usually with a clock. The 113AR Frequency Divider and Clock provides high comparison accuracy. Time comparison to 10 microseconds provides a comparison accuracy of 1 part in 10^{10} if comparisons are made over a 24-hour period. With the 113AR, the drift of an oscillator with respect to WWV may be periodically measured, and corrections to the oscillator may be made if necessary. The 524C/D oscillators can be compared with WWV by using the 113AR. Time comparison is discussed in Paragraph 2-5.

PASSIVE ELEMENTS

Frequency calibration of passive elements is accomplished by adjusting a signal-source frequency for resonance in the passive element and then measuring that frequency. The accuracy of measurement depends upon the resolution of the indicating system and the Q of the passive element. At frequencies from 10 mc to 1230 mc, MOPA oscillators are sine-wave modulated, and a 415B Standing Wave Indicator is used as the indicator. For higher frequencies a klystron

is frequency modulated and the mode plot displayed on an oscilloscope. These techniques are described in more detail in Paragraph 2-4.

**2-2 FREQUENCY MEASUREMENTS
BETWEEN 0 AND 220 MEGACYCLES**
GENERAL

Frequencies up to 220 megacycles can be measured directly with the 524 Electronic Counter and 525A and 525B Frequency Converter plug-in units. The period of signals up to 10kc can be measured with the 524 Counter and 526C Period Multiplier plug-in. The choice of making either a period or a frequency measurement depends upon the frequency of the signal and the signal-to-noise ratio. Figure 2-1 shows the accuracy attainable with the 524C/D Counter and 526C Period Multiplier. The accuracy of frequency

measurement depends upon the ± 1 -count ambiguity inherent in any frequency counter and upon the stability of the standard oscillator in the counter. At low frequencies, the ± 1 count is the predominant factor. The accuracy of a frequency measurement for a 10-second gate time is shown in Figure 2-1. Shorter gate times give proportionally less accuracy. At a frequency of 10 megacycles the accuracy approaches the stability of the oscillator in the 524D.

Period measurement accuracy depends upon the ± 1 -count ambiguity, oscillator stability, signal rise time, signal noise, and any trigger ambiguity in the start-stop circuit. For most accuracy, the 10-megacycle frequency is counted. The possible error is shown in Figure 2-1 for a 1-volt sine-wave signal with a 40-db signal-to-noise ratio and also for a pulse or square wave. The 524D Electronic Counter alone permits either a one-period measurement or a meas-

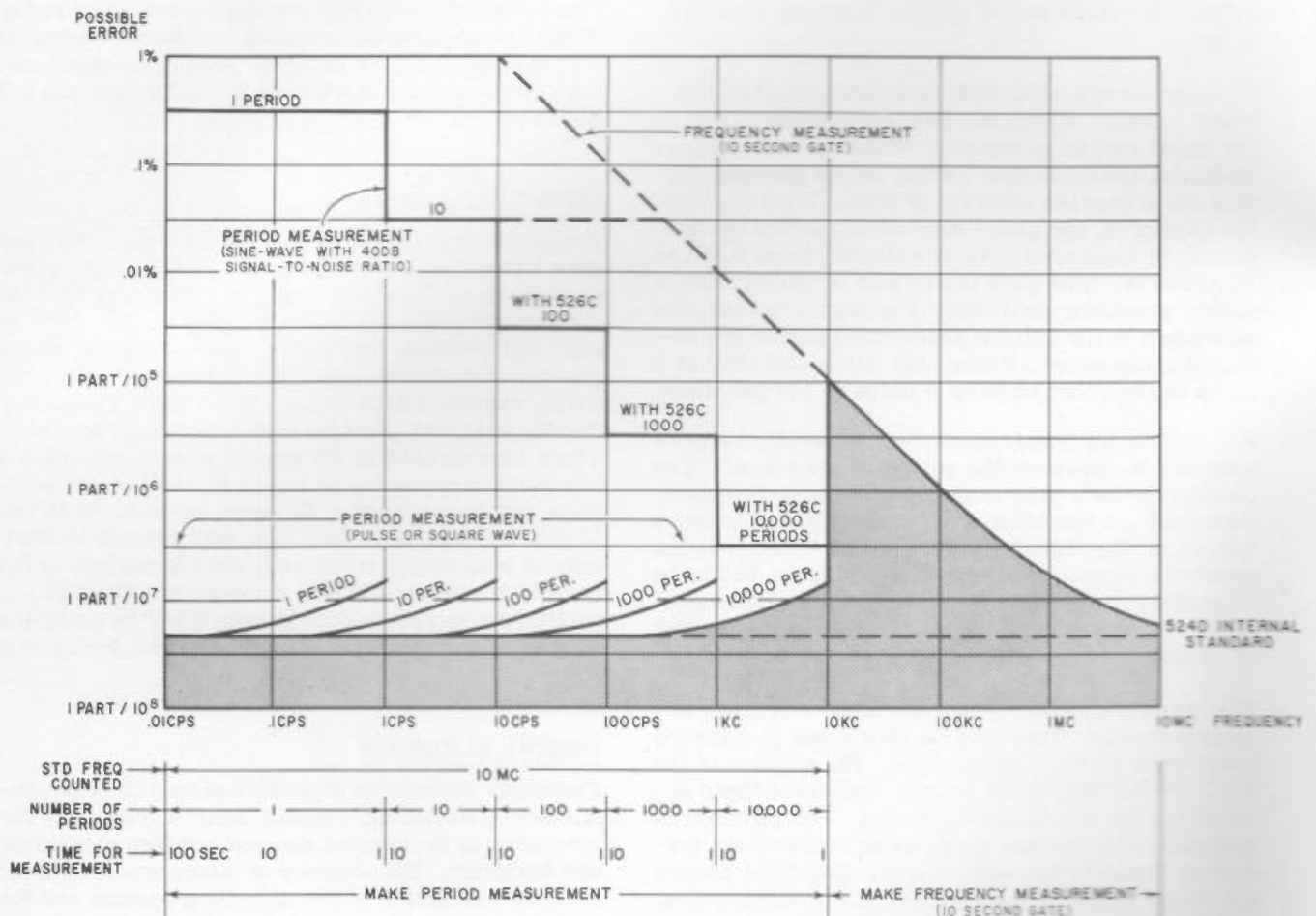

Figure 2-1. Attainable Accuracy of the 524D Electronic Counter with the 526C Period Multiplier using Long-Term Stability for the Counter Oscillator

urement average over ten periods. The 526C Period Multiplier permits averages over 100, 1000, and 10,000 periods, thereby increasing the accuracy over the frequency range up to 10 kc. The accuracy with a one-period measurement and 40-db signal-to-noise ratio is 0.3%. Using a ten-period average the accuracy is tenfold greater. A signal with a better signal-to-noise ratio will give proportionally more accuracy. The maximum is that obtained by using either a fast-rise-time pulse or square wave.

Other considerations exist for frequency measurements. The amplitude of the signal must be large enough to operate the Electronic Counter properly. To avoid triggering on noise, the 524 has a basic sensitivity of 1 volt rms. When noise is not a factor the 525A/B Frequency Converter or 526A Video Amplifier provides increased sensitivity. If the amplitude of the signal is still not large enough to operate the Counter properly, a suitable amplifier may be used. For all frequency measurements, be sure that the Counter does not trigger on noise or other unwanted signals.

ACCURACY

The possible error of a frequency measurement for any gate time may be computed from the formula:

$$E = R + \frac{1}{fT}$$

where

R = Stability of the Counter oscillator

f = Signal frequency

T = Gate time of Counter.

For example, the possible error in measurement of 10 kc with a 10-second gate time, using the 524D Counter, is:

$$E = \frac{5}{10^8} + \frac{1}{(10^5)(10)}$$

$$\approx 1/10^6 \text{ or 1 part in } 10^6$$

For period measurements of fast-rise-time pulses where triggering ambiguity is negligible, the possible error is:

$$E = R + \frac{1}{FPN}$$

where

F = Standard frequency counted by the Counter

P = Period of signal in seconds

N = Number of periods averaged by Counter.

If the crystal oscillator of the 524D Electronic Counter is periodically standardized with WWV, frequencies may be measured with the accuracies shown in Figure 2-1. The accuracy in frequency measurements above 10 megacycles is chiefly determined by the stability of the crystal oscillator. The ± 1 -count ambiguity also applies, but is generally negligible compared with the oscillator stability. The stability for the 524D Electronic Counter is 5 parts in 10^8 per week.

PRELIMINARY INSTRUCTIONS (See Figure 2-2.)

- 1) Connect the 524D Electronic Counter to 115V ac with the Power switch (1) in the STANDBY position, and allow crystal to warm up for three hours. A good practice is to leave the power cord always connected to the line. The crystal oven then remains at a constant temperature.
- 2) With the Power switch (1) in the STANDBY position, install any plug-in unit. Turn the Power switch (1) to ON and allow 5 minutes for warmup.
- 3) Set the MANUAL GATE switch (3) to CLOSED.
- 4) Set the FUNCTION SELECTOR switch (4) to the 100 KC CHK position.
- 5) Adjust the DISPLAY TIME control (6) for the desired display. The extreme counterclockwise position is usually the best.

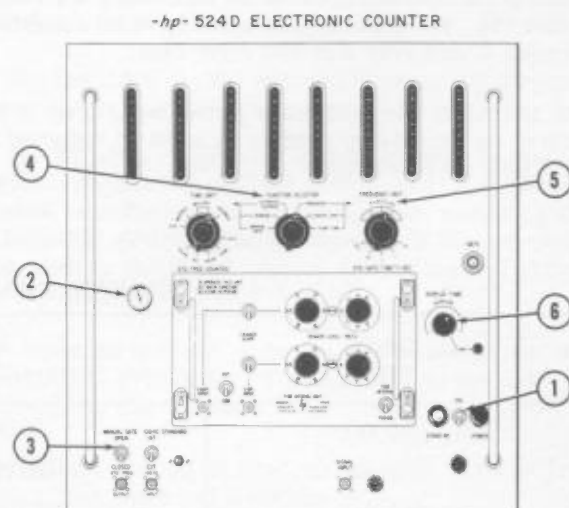

Figure 2-2. 524D Electronic Counter for Self-Check

6) Note the readings obtained on the display system for each position of the FREQUENCY UNIT switch (5). These readings should agree with the values in Table 2-1.

7) Set the FUNCTION SELECTOR switch (4) to the 10 MC CHK position.

8) Note the readings obtained on the display system for each position of the FREQUENCY UNIT switch (5). These values should agree with the values in Table 2-1. However, when checking 10 mc, note that a discrepancy of ± 1 count in the last digit is acceptable, because of tolerance in the operation of the gate circuits.

PROCEDURE FOR MEASURING FREQUENCIES BETWEEN 0.01 CPS AND 10 KC (See Figure 2-3.)

1) Use the 526C Period Multiplier plug-in. Set the Power switch to the STANDBY position before changing the plug-in. Then set the Power switch back to ON.

2) Set the FUNCTION SELECTOR switch (2) to PERIOD or to 10 PERIOD AVERAGE. Set the Period Multiplier switch to the position for the desired number of periods. Set the TIME UNIT switch (3) to the desired time unit (usually set to produce the largest number of counts).

For greatest accuracy, use the settings in Table 2-2.

Set DISPLAY TIME control (4) for the desired display time (usually fully counterclockwise).

Connect the source signal to the SIGNAL INPUT connector (5). The input signal must have an amplitude between 1 volt rms and 200 volts rms.

The period of the frequency being measured is indicated on the display system in units as selected by the TIME UNIT switch.

TABLE 2-2. CONTROL SETTINGS

Frequency	TIME UNIT Setting	Number of Periods
0.01 to 1 cps	10 mc	1
1 to 10 cps	10 mc	10
10 to 100 cps	10 mc	100
100 cps to 1 kc	10 mc	1000
1 kc to 10 kc	10 mc	10,000

Frequency (cps) is then given by the following formula: $F = 1/P$ where P is the period of the measured signal indicated on the display system in seconds.

PROCEDURE FOR MEASURING FREQUENCIES BETWEEN 10 KC AND 10.1 MC (See Figure 2-4.)

1) Any plug-in unit may be used. Sensitivity with the 526B Time Interval unit is 1 volt rms. The 525A Frequency Converter provides sensitivity down to 0.1 volt rms, and the 525B Frequency Converter provides sensitivity to 0.2 volt rms. Set the Power switch to the STANDBY position before changing the plug-in. Then set the Power switch to ON.

2) Set the FUNCTION SELECTOR switch (1) to FREQUENCY.

3) Set the FREQUENCY UNIT switch (2) to the desired gate time (use 10 seconds for greatest accuracy).

TABLE 2-1. COUNTER READINGS FOR SELF-CHECK OPERATIONS

GATE TIME	100 KC CHECK	10 MC CHECK *
10 sec	0100.0000	0000.0000 ± 0.0001
1 sec	00100.000	10000.000 ± 0.001
0.1 sec	000100.00	010000.00 ± 0.01
0.01 sec	0000100.0	0010000.0 ± 0.1
0.001 sec	00000100.	00010000. $\pm 1.$

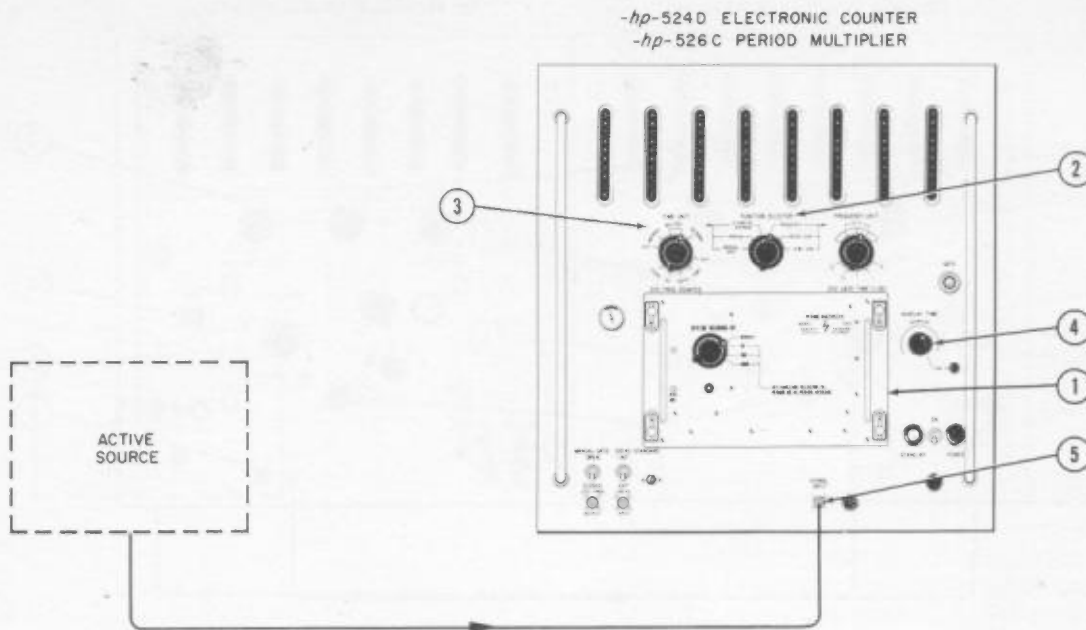

Figure 2-3. Frequency Measurement from 0.01 to 10 KC

- 4) Set the DISPLAY TIME control (3) to the desired display time (usually fully counterclockwise).
- 5) Connect the signal from the source to the SIGNAL INPUT connector.

NOTE

If a 525A Frequency Converter is used, set the MIXING FREQUENCY control (5) to "0" and adjust the GAIN control (6) until the tuning eye just closes. If a 525B Frequency Converter is used, set the MIXER-DIRECT-WAVEMETER switch to DIRECT.

- 6) Read the frequency on the display system in kilocycles.

PROCEDURE FOR MEASURING FREQUENCIES BETWEEN 10.1 and 100 MC (See Figure 2-5.)

- 1) Use the 525A Frequency Converter plug-in unit. The sensitivity is 10 mv to 1 volt rms. Set the power switch to the STANDBY position before changing the plug-in. Then set the Power switch to ON.
- 2) Set the FUNCTION SELECTOR switch (1) to FREQUENCY.
- 3) Set the FREQUENCY UNIT switch (2) to the desired gate time (usually 1 or 10 seconds).

- 4) Set the DISPLAY TIME control (3) to the desired display time (usually fully counterclockwise).
- 5) Connect the signal from the source to the SIGNAL INPUT connector (4).

- 6) Set the MIXING FREQUENCY switch (5) to TUNE.
- 7) Set the GAIN control (6) to its maximum clockwise position.
- 8) Set the RANGE-MC switch (7) to the 10-20 position.

- 9) Set TUNING control (8) to the left end of the "10" region. Adjust the control slowly until a minimum shadow is obtained on the tuning eye, changing the RANGE-MC switch (7) as necessary. If the eye overlaps, reduce the GAIN control (6) setting and retune the TUNING control (8).

- 10) When an indication on the eye is observed, set the MIXING FREQUENCY control (5) to the position indicated by the TUNING dial.

- 11) Adjust the GAIN control (6) until the eye just closes, but does not overlap.

- 12) Source frequency is obtained by adding the reading of the MIXING FREQUENCY switch (5) (frequency in mc) to the reading on the display system (frequency in kc).

-hp- 524 D ELECTRONIC COUNTER

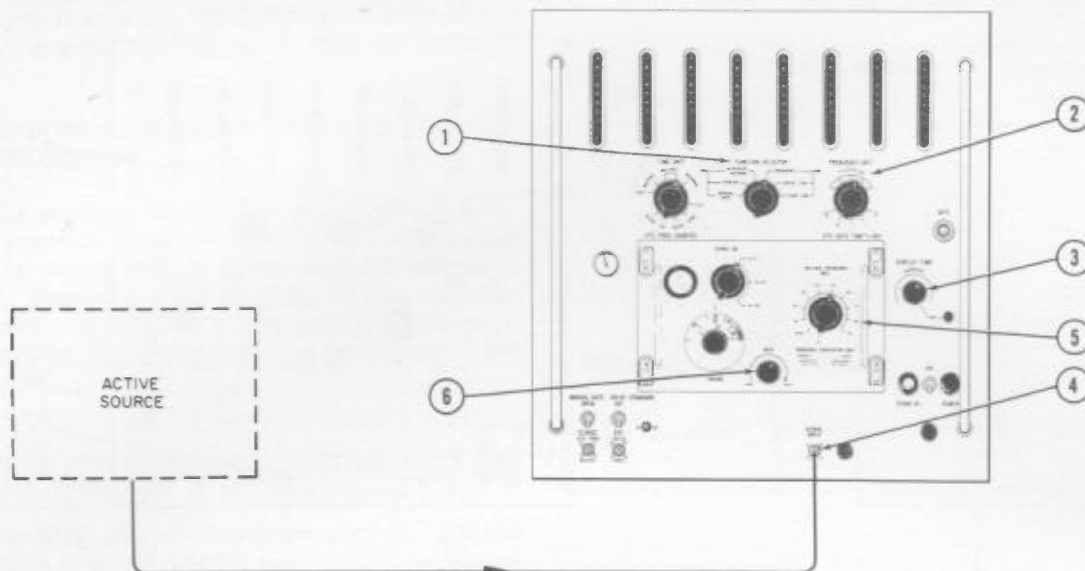

Figure 2-4. Frequency Measurement between 10 KC and 10.1 MC

PROCEDURE FOR MEASURING FREQUENCIES BETWEEN 100 MC AND 220 MC (See Figure 2-6.)

- 1) Use the 525B Frequency Converter plug-in. The sensitivity is 0.2 volt rms. Set the Power switch to the STANDBY position before changing the plug-in. Then set the Power switch to ON.
- 2) Set the FUNCTION SELECTOR switch (1) to FREQUENCY.
- 3) Set the FREQUENCY UNIT switch (2) to the desired gate time (usually 1 or 10 seconds).
- 4) Set the DISPLAY TIME control (3) to the desired display time (usually fully counterclockwise).
- 5) Connect the signal from the source to the INPUT connector (4) on the Converter panel.
- 6) Set the MIXER-DIRECT-WAVEMETER switch (5) to WAVEMETER.
- 7) Tune the Mixing Frequency control dial (6) until the tuning eye closes.
- 8) Set the MIXING FREQUENCY control (7) to the Position indicated by the Mixing Frequency control dial (6).
- 9) Set the MIXER-DIRECT-WAVEMETER switch (5) to MIXER.
- 10) The source frequency is obtained by adding the reading of the MIXING FREQUENCY control (fre-

quency in mc) to the reading on the display system (frequency in kc).

NOTE

Always set the MIXING FREQUENCY switch to obtain a reading of at least 10 kc on the 524D, to avoid erratic readings.

2-3 FREQUENCY MEASUREMENTS BETWEEN 220 MEGACYCLES AND 12.4 KMC

GENERAL

Frequencies between 220 megacycles and 12.4 kmc are accurately measured with the 540B Transfer Oscillator, 524 Electronic Counter and 525B Frequency Converter. Frequencies higher than 12.4 kmc are measured with external waveguide mixers and harmonic generators. For example, in the P band the P932A Harmonic Mixer may be used. With the 540B Oscillator and 524 Counter, cw, fm, and pulse-modulated signals can be measured. In addition, the residual frequency modulation of cw signals, the limits of incidental frequency deviation in amplitude-modulated signals, and the limits of frequency deviation in frequency-modulated signals can also be measured.

The 540B Transfer Oscillator has a 100- to 220-megacycle oscillator, a low frequency and a high frequency mixer, a video amplifier, and an oscilloscope. Input and output terminals for all circuits are

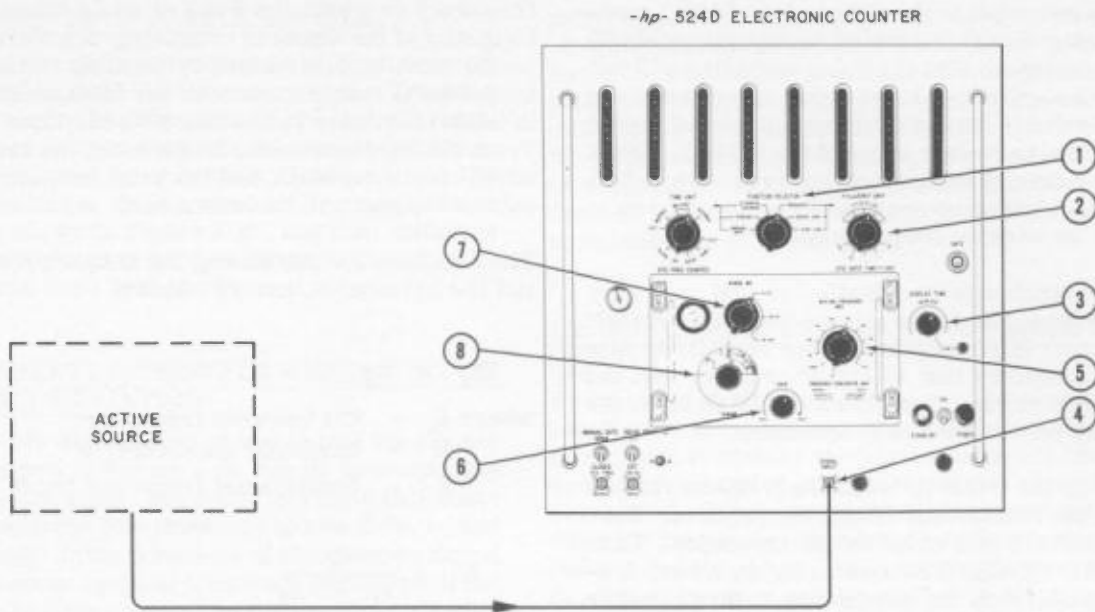

Figure 2-5. Frequency Measurement between 10.1 MC and 100 MC

brought out to the front panel so that the instrument may be operated in a number of different ways. For frequency measurement the oscillator is tuned so that one of its harmonics mixes with the unknown signal. When the harmonic and the unknown signal frequency

are identical, a zero beat is indicated on the oscilloscope. The frequency of the oscillator is then accurately measured with the Electronic Counter and the harmonic number determined. The frequency of the unknown signal can then be calculated.

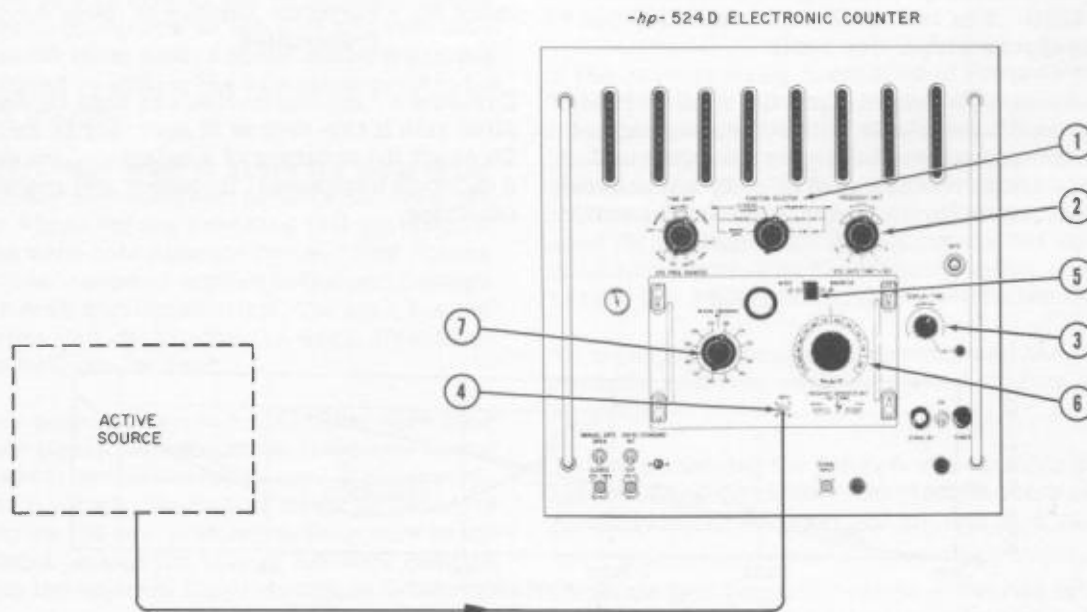

Figure 2-6. Frequency Measurement between 100 MC and 220 MC

The peak power input to the mixer of the 540B Transfer Oscillator should be limited to approximately 20 milliwatts to insure that the video amplifier will not be overdriven. If a high-level signal is measured, an attenuator suitable for the frequency measured should be inserted in the system ahead of the SIGNAL INPUT jack. The mixer sensitivity curves (see Figure 2-7) indicate the minimum power required to make measurements at various frequencies.

The values obtainable in a particular unit may vary somewhat from the curve values because crystals have different efficiencies. Actual sensitivity at a particular frequency may be higher or lower than the average value shown. Variations of ± 10 db from the curves may occur at some frequencies.

When tuning the 540B to measure frequency, first determine the fundamental frequency required. Turn the FREQUENCY dial close to this frequency. Tune the COARSE VERNIER control to obtain a beat-frequency response on the oscilloscope; then tune the FINE VERNIER control to obtain the exact zero-beat indication. The range of the FINE VERNIER control is small, so the COARSE VERNIER control should be tuned as close as possible to the zero beat with the FINE VERNIER control set to the center of its range.

The 525B Frequency Converter conducts a few millivolts of its mixing frequency to the INPUT jack. If the 540B is tuned to beat with this mixing frequency, a beat-frequency indication will appear on the oscilloscope. Do not confuse this zero beat with desired beats with the unknown input signal. Normally, this false beat will be weaker than the true beat. Check the beat by momentarily removing the cable connected to the 525B. The indication on the oscilloscope will not disappear with a true beat.

When measuring any unknown signal for the first time, one of two conditions arises: either the frequency of the signal is completely unknown, or its approximate frequency is known and can be divided by some harmonic number in order to arrive at the fundamental

frequency to which the 540B must be tuned. If the frequency of the signal is completely unknown, a harmonic must be determined by locating two adjacent fundamental frequencies with the 540B which result in beat-frequency indication with the input signal. From the two fundamental frequencies, the harmonics which create the beats, and the exact frequency of the unknown signal can be determined.

The equations for calculating the unknown frequency, and the harmonics, are as follows:

$$f_x = Nf$$

- where f_x - the unknown frequency
- N - harmonic number
- f - fundamental frequency for N

$$N_1 = \frac{f_2}{f_1 - f_2}$$

- where N_1 - harmonic number of higher fundamental frequency
- f_1 - larger of two fundamental frequencies
- f_2 - smaller of the two fundamental frequencies

$$N_2 = \frac{f_1}{f_1 - f_2}$$

- where N_2 - harmonic number of lower fundamental frequencies

Division or multiplication can then be done with a slide rule if this degree of accuracy is satisfactory. To check the accuracy of a calculated answer, select a different fundamental frequency and repeat the calculations.

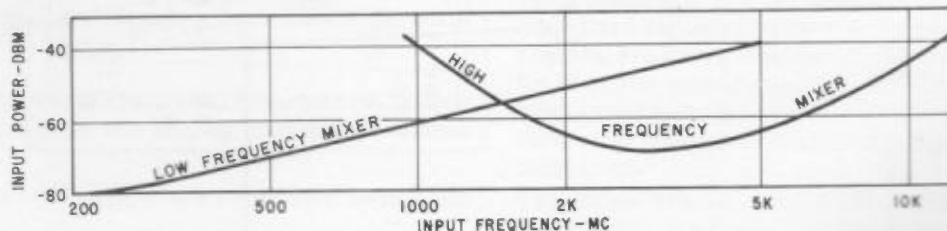

Figure 2-7. Typical Mixer Input Sensitivity

MEASUREMENTS OF STABLE SIGNALS

If a sufficiently stable cw signal is being measured, the operator adjusts the frequency of the Transfer Oscillator until a beat-frequency presentation similar to Figure 2-8a is obtained, where a low but significant difference frequency is displayed. As the operator continues tuning, the oscilloscope pattern changes, as shown in Figure 2-8b, and then collapses to a straight horizontal line, as shown in Figure 2-8c, when the true zero beat is obtained.

MEASUREMENTS OF SIGNALS WHICH CONTAIN FREQUENCY DEVIATION

In practice few signals are so stable that the simple zero beat shown in Figure 2-8c can be obtained. Instead, the usual signal has such instability that beat-frequency patterns like those in Figures 2-9a, b, and c are obtained. If the frequency of the unknown signal varies (has some residual frequency modulation), the difference frequency viewed on the oscilloscope also varies, and the exact zero beat is situated in the center of a band of difference frequencies all shown simultaneously on the oscilloscope screen. Such a pattern is shown in various degrees in Figure 2-9. Figures 2-9a and 2-9b show two typical beat-frequency responses of signals containing minor amounts of residual frequency deviation. Figure 2-9c shows a larger amount of frequency deviation. When such responses are obtained while tuning the 540B, a low beat frequency is approached. Then the exact zero-beat point begins to appear somewhere on the screen. It moves about on the screen and then disappears. If the frequency modulation occurs at 60- or 120-cycle rate the PHASE control can be adjusted so that the zero beat first appears on one side and then disappears from the other side, and the center frequency can be measured by setting the zero-beat point to the center of the pattern.

The exact zero-beat point is where the lines in the patterns become expanded horizontally and then reverse their slope before reaching full amplitude. Note that the zero beat appears twice. This occurs because the line frequency applied to the oscilloscope sweeps it in both directions; thus, the zero beat is crossed twice per cycle, once in each direction. Either zero beat can be used.

If the pattern cannot be synchronized (the zero beat stopped in one place), the modulation frequency on the carrier differs from the line frequency. If necessary, the 540B oscilloscope can then be swept at the same rate by applying the new modulation frequency to the Horizontal Input jack on the rear of the 540B chassis and switching the adjacent toggle switch to External.

If the residual frequency modulation is accompanied by amplitude modulation, the amplitude of the overall

pattern on the oscilloscope will be altered without affecting readability or resolution. Amplitude modulation is indicated by a difference in amplitude of the pattern at the forward and backward traces on the oscilloscope. If the amplitude modulation occurs at the 60-cycle power-line frequency, the phase control can be adjusted to superimpose the two traces and produce the familiar trapezoid associated with amplitude modulation.

MEASUREMENTS OF FREQUENCY-MODULATED SIGNALS

Frequency-modulated rf signals are measured in exactly the same manner as cw signals. The effect of residual frequency modulation upon the beat-frequency presentation of a cw signal has already been described. The presentation obtained when measuring a frequency-modulated carrier is the same, but the deviation is usually much greater, and the zero-beat point is much smaller in relation to the entire frequency swing (see Figure 2-9a in contrast to Figure 2-10).

To obtain readable zero-beat patterns when the center frequency and the limits of frequency deviation in frequency-modulated carriers are measured, the oscilloscope in the 540B must be swept by the same frequency signal that modulates the carrier. The 540B oscilloscope is internally swept at the power-line frequency. So for most straightforward operation, the carrier frequency being measured must also be frequency-modulated at the power-line frequency. In addition, to obtain the simplest possible zero-beat oscilloscope pictures, the modulation should be sine-wave rather than complex.

If the carrier being measured is frequency modulated at a rate different from the power-line frequency, this modulation signal must be applied to the External Sweep Input jack on the rear of the 540B chassis, and the adjacent toggle switch must be set to Ext. Of course, if an external sweep voltage is used the internal 540B PHASE control has no effect. Also for power-line frequencies much above 120 cycles the PHASE control is ineffective.

To measure the center frequency and the limits of deviation of a frequency-modulated carrier, proceed as follows:

- 1) For measuring the frequency of cw signals, follow the instructions below, "Procedure for Frequency Measurements Between 220 mc and 12.4 kmc."
- 2) As the beat frequency varies at the rate of the frequency modulation, it is not possible to reduce the beat frequency to a simple zero. Instead, the carrier frequency sweeps through a zero beat with the



a



b



c

Figure 2-8. Typical Sequence of Patterns Obtained as Difference Frequency is Reduced to Zero on a Stable Signal

540B twice during each cycle of modulation, first in one direction, then in the other. Consequently, two zero-beat points appear simultaneously on the 540B oscilloscope sweep. With the phase control, superimpose the two zero beats or separate them so that they do not interfere. Figures 2-10a and 2-10d show the beat superimposed while the 540B is tuned to the approximate center frequency of the carrier. Figures 2-10b and 2-10c show the same pattern as it appears with the 540B tuned first to one limit of frequency deviation, then to the opposite limit of deviation.

A complete discussion of measuring pulsed rf signals appears in the Addenda.

ACCURACY

The accuracy of frequency measurements above 220 megacycles depends primarily upon the stability of the oscillator in the Electronic Counter, the stability of the unknown signal, and the error of comparison, and somewhat upon the stability of the 540B oscillator. The error of comparison is the error in the setting of the 540B for zero beat. As the measurement time is usually small, the error due to the instability of the 540B oscillator is negligible. If the unknown signal is significantly more stable than 1 part in 10^7 (the error of comparison), then the at-



a



b



c

Figure 2-9. Typical Scope Patterns Obtained when Signal to be Measured has Some Frequency Deviation

tainable accuracy of the measurement approaches the stability of the internal standard of the electronic counter, or the error of comparison, whichever is greater. If the signal has an instability of the same magnitude as or greater than the error of comparison, the accuracy of the measurement diminishes.

PROCEDURE FOR FREQUENCY MEASUREMENTS BETWEEN 220 MC AND 12.4 KMC

1) Check the 524D Electronic Counter thermometer to insure that it is up to operating temperature. If the 524D power cord has been disconnected for any appreciable amount of time, a 3-hour warmup is required with the Power switch in the STANDBY position.

When the 524D crystal reaches operating temperature, set the 540B Transfer Oscillator and the 524D Electronic Counter Power switches to the ON position and allow them to warm up for at least 5 minutes.

Self-check the 524D Electronic Counter to insure proper operation.

2) For the measurement of frequencies between 220 mc and 5 kmc, connect the signal from the source to the 540B Transfer Oscillator **LOW FREQUENCY MIXER SIGNAL INPUT** jack, as shown in Figure 2-11.

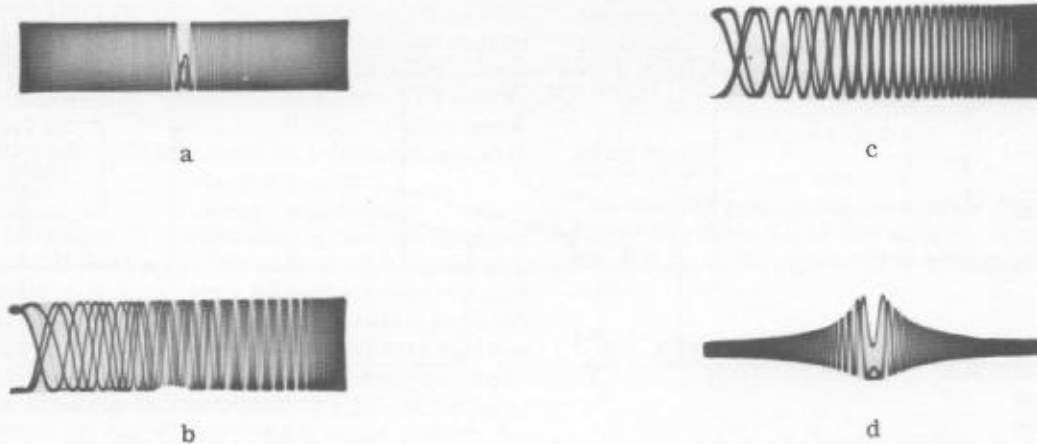

- a) When Signal has Wide Frequency Deviation
 b, c) When Zero Beat is Adjusted to Occur at the Limits of Frequency Deviation
 d) When Deviation is so Wide that Display is Limited by the Bandwidth of the Vertical Amplifier

Figure 2-10. Typical Patterns Obtained with Frequency-Modulated RF Signals

For the measurement of frequencies between 5 kmc and 12.4 kmc, connect the signal from the source to the 540B Transfer Oscillator HIGH FREQUENCY MIXER SIGNAL INPUT jack, as shown in Figure 2-12.

3) Set the 540B VIDEO RESPONSE controls to their maximum positions (clockwise).

4) Turn the 540B FINE VERNIER control to the center of its rotation (white dot straight up).

5) Set the 524D Electronic Counter controls as follows:

FUNCTION SELECTOR switch to FREQUENCY.
 FREQUENCY UNIT switch to desired gate time.
 DISPLAY TIME control fully counterclockwise.

6) Tune the 540B Transfer Oscillator COARSE VERNIER control until a response is seen on the oscilloscope. Adjust the INTENSITY and FOCUS controls for a clear trace. Tune as close to zero beat as is conveniently possible with the COARSE VERNIER control.

NOTE

For more trace resolution, use the 120A or 130B Oscilloscope. Connect the vertical input to the 540B Transfer Oscillator VIDEO OUTPUT jack.

7) With the 540B FINE VERNIER tuning control, reduce the difference-frequency response on the oscilloscope to as close to zero beat as the stability of the measured signal allows. Absolute zero beat is obtained when the oscilloscope trace appears as a horizontal line. Various looped patterns appear as the 540B is tuned slightly away from the measured frequency. Check for true beat by momentarily disconnecting the cable connected to the 525B.

8) Measure the fundamental frequency of the mixing signal with the 524D Electronic Counter by setting the MIXER-DIRECT-WAVEMETER switch to WAVE-METER. Tune the Mixing Frequency Selector dial until the tuning eye closes. Set the MIXING FREQUENCY control to the position indicated by the Mixing Frequency Selector dial. Set the MIXER-DIRECT-WAVEMETER to MIXER. The fundamental frequency is obtained by adding the reading of the MIXING FREQUENCY control (frequency in mc) to the reading on the 524 display system (frequency in kc). It is also indicated on the 540B Transfer Oscillator tuning dial. (Always set the MIXING FREQUENCY switch to obtain a reading of at least 10 kc on the 524D, to avoid erratic readings.)

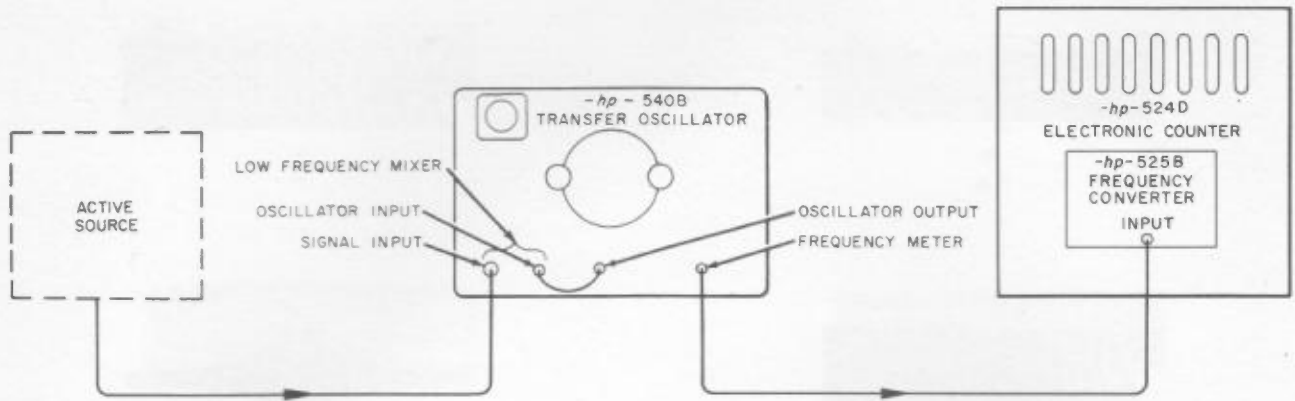

Figure 2-11. Frequency Measurements between 220 MC and 5 KMC

9) Tune the 540B Transfer Oscillator COARSE VERNIER control to an adjacent 540B Transfer Oscillator mixing frequency which produces a zero beat, and measure the fundamental frequency with the 524D Electronic Counter as before. When two adjacent Transfer Oscillator frequencies produce zero beats, the harmonic number (N_1) of f_1 can be found by following the formula: $N_1 = f_2 / (f_1 - f_2)$, where N_1 is always a whole number, and f_1 is the larger of the two fundamental frequencies.

$$N_1 = \frac{200}{220 - 200} = 10$$

$$f_x = (10) \times (220) = 2200 \text{ mc}$$

The frequency of the source is then $f_x = N_1 f_1$

Example:

$$f_1 = 220 \text{ mc}$$

$$f_2 = 200 \text{ mc}$$

2-4 FREQUENCY MEASUREMENTS OF PASSIVE ELEMENTS

GENERAL

The resonant frequency of a passive element can be measured using the 415B Standing Wave Indicator to indicate resonance. The equipment is connected as shown in Figure 2-13. The Signal Generator output signal is 1000-cycle modulated and subsequently detected with a crystal detector. The frequency of

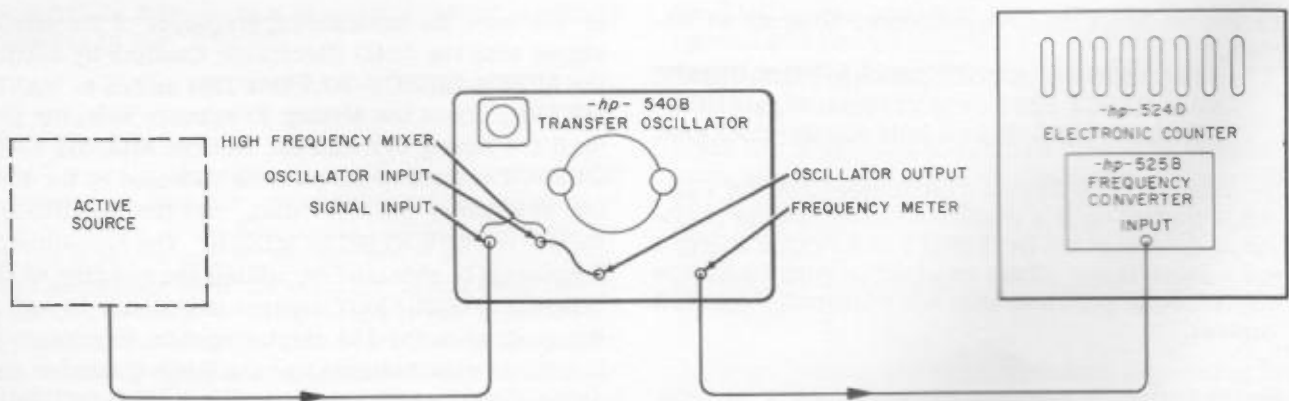

Figure 2-12. Frequency Measurements between 5 KMC and 12.4 KMC

the Signal Generator is adjusted for a resonance indication on the Standing Wave Indicator. The frequency on the Signal Generator is then measured with the 524 Electronic Counter and 525B Frequency Converter. For measurements above 220 megacycles, the 540B Transfer Oscillator is also used. This technique does not require a frequency-modulated source.

Another technique for calibrating a passive element uses an oscilloscope for the indicating instrument. This technique is used when a frequency-modulated source is available. This system is typically used in the higher frequency ranges to calibrate instruments such as frequency meters. The repeller voltage of the klystron is modulated at a 60-cycle rate. The detected fm signal provides a mode plot on the oscilloscope. Part of the Signal Generator signal is mixed with a harmonic from the 540B Oscillator to provide a zero-beat pip which is also displayed on the oscilloscope. The oscillator of the 540B is monitored with an electronic counter. Hence, the frequency of the pip is precisely known. Adjusting the passive element produces a notch on the mode plot when the resonant point is reached. When the notch coincides with the pip, the passive element is at the frequency of the pip.

A variable resistor, as shown in Figure 2-17, is connected between the detector mount and the oscillo-

scope. This variable resistor permits adjustment of the amplitude of the mode plot independently from that of the pip. Hence, the display can be adjusted to provide maximum resolution.

ACCURACY

The accuracy of the measurement depends upon the figure of merit (Q) of the passive element and upon the ability of the operator to adjust for exact resonance.

$$\frac{f-f_0}{f_0} = \frac{0.707\sqrt{\alpha}}{Q} \quad \text{where} \quad \alpha = \text{error of the setting in amplitude}$$

$$\text{for example, if } \alpha = 0.25\%, \quad \frac{f-f_0}{f_0} = \frac{0.035}{Q}$$

where $\frac{f-f_0}{f_0}$ is the error in the measurement.

PROCEDURE FOR FREQUENCY MEASUREMENT OF PASSIVE ELEMENTS BETWEEN 10 AND 1230 MC

- 1) Connect the equipment as shown in Figure 2-13.

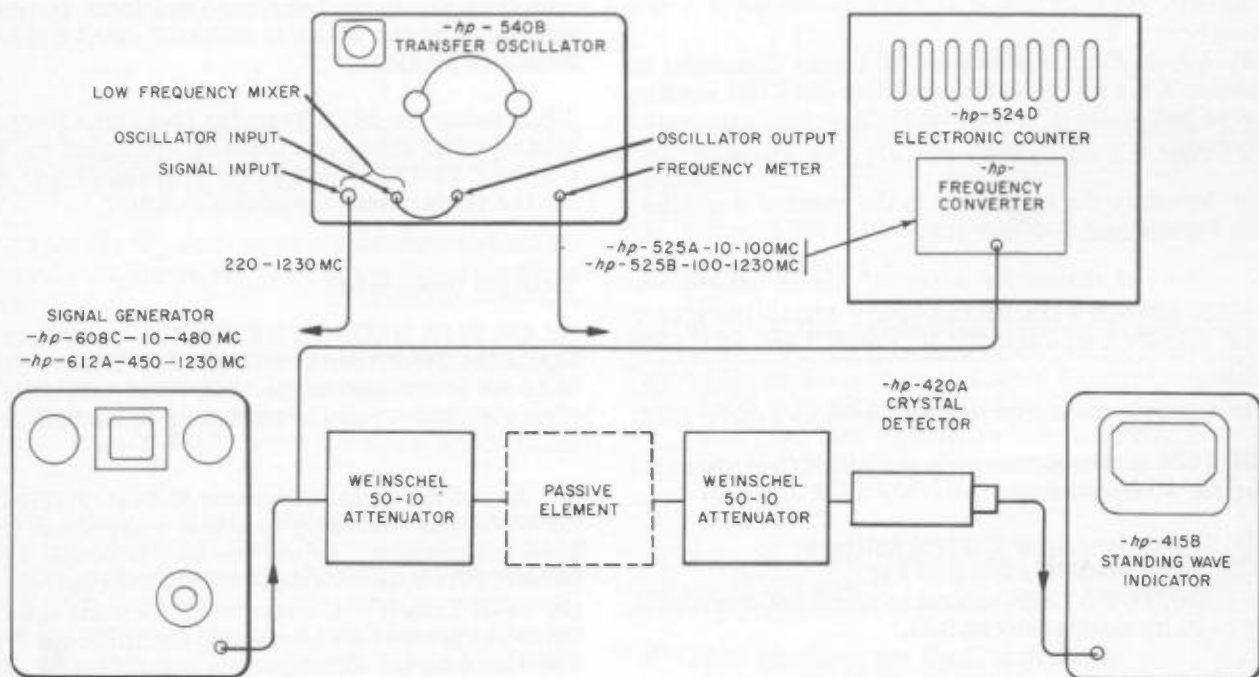

Figure 2-13. Frequency Measurements of Passive Elements

For measurements from 220 to 1230 mc, use the 540B Transfer Oscillator.

2) Connect the equipment to 115V ac power. Turn on the equipment and allow it to warm up for 10 minutes.

3) 415B Standing Wave Indicator Control Settings:
INPUT SELECTOR switch to either CRYSTAL position.
RANGE switch to 40.
METER SCALE switch to EXPAND.
GAIN control to maximum.

4) Signal Generator Control Settings:
Modulation Selector switch to CW.
Attenuator control to 0 dbm.
OUTPUT LEVEL control for a SET LEVEL meter reading.
612A Signal Generator - Modulation switch to NORMAL.

5) Adjust the AMP. TRIMMER control on the 608C Signal Generator for a maximum indication on the Output Level meter, reducing the reading as necessary with the OUTPUT LEVEL control.

6) Set the Modulation Selector switch to 1000 \sim . Adjust the MOD. LEVEL control for a reading of about 30% on the Modulation meter.

7) Set the Signal Generator attenuator to obtain a full-scale deflection on the 415B Standing Wave Indicator.

8) Adjust the frequency of the Signal Generator to obtain a dip on the 415B, and keep the 415B reading near full scale with the Signal Generator attenuator control.

9) Measure the frequency in the manner described in Paragraphs 2-2 and 2-3.

PROCEDURE FOR FREQUENCY MEASUREMENT OF PASSIVE ELEMENTS BETWEEN 800 AND 4000 MC

1) Connect the equipment as shown in Figure 2-14.

2) Turn on all instruments and allow them to warm up for 10 minutes.

3) Signal Generator Control Settings:
FM-CW-OFF switch to FM.
OUTPUT ATTEN control to minimum attenuation (fully counterclockwise).

4) 540B Transfer Oscillator Control Settings:
LOW FREQ, GAIN, and HIGH FREQ controls fully clockwise.

5) 130B Oscilloscope Control Settings:
VERT. SENSITIVITY to 0.2 VOLTS/CM.
AC/DC switch to AC.
SYNC. switch to LINE.
TRIGGER SLOPE switch to +.
SWEEP TIME/CM switch to 1 MILLISECOND.

6) 524D Electronic Counter Control Settings:
FUNCTION SELECTOR switch to FREQUENCY.
FREQUENCY UNIT control to the desired gate time (usually 1 second).
DISPLAY TIME control to the desired time (usually fully counterclockwise).

7) Set the Signal Generator SIGNAL FREQUENCY control to the frequency for passive element calibration. Adjust the FM AMPLITUDE and FM PHASE controls for a mode plot on the Oscilloscope.

8) Set the 540B Transfer Oscillator FREQUENCY dial to a frequency that is a subharmonic of the calibration frequency.

Example :

If it is desired to calibrate the passive element at 3600 mc, set the 540B Transfer Oscillator FREQUENCY dial to 180 mc. 3600 mc is the 20th harmonic of 180 mc.

9) Set the 525B Frequency Converter MIXING FREQUENCY control to a reading from 0.1 mc to 10 mc less than the 540B Transfer Oscillator frequency setting. Set the MIXER-DIRECT-WAVEMETER switch to MIXER.

10) Monitor the 540B Transfer Oscillator frequency with the 524D Electronic Counter, and adjust the 540B COARSE VERNIER and FINE VERNIER controls to set the fundamental frequency exactly.

Example (continued):

Set the 525B MIXING FREQUENCY to 170 mc and adjust the 540B Transfer Oscillator until a reading of 10 mc is obtained on the 524D Electronic Counter. Thus the 540B Transfer Oscillator is now set at 180 mc.

11) Adjust the Signal Generator SIGNAL FREQUENCY control as necessary to obtain a zero-beat pip on the Oscilloscope. Adjust the Oscilloscope VERT. SENSITIVITY and SWEEP TIME/CM controls and the 540B Transfer Oscillator GAIN control as required to produce an acceptable Oscilloscope trace. The trace on the Oscilloscope should appear as in Figure 2-15. Readjust the Signal Generator FM AMPLITUDE and FM PHASE controls as necessary. The zero-beat pip represents the test frequency.

-hp- 614A SIGNAL GENERATOR
800 TO 2100 MC
OR
-hp- 616A SIGNAL GENERATOR
1800 TO 4000MC

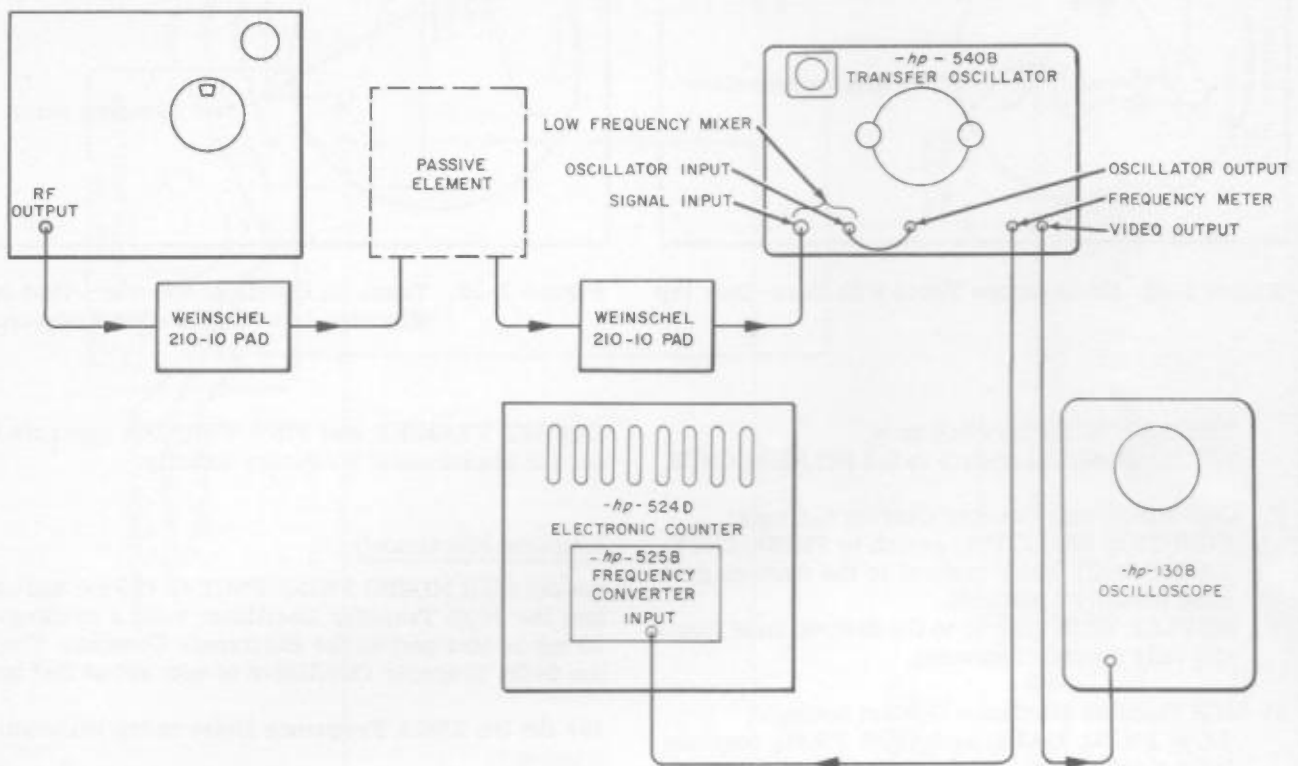

Figure 2-14. Frequency Measurement of Passive Elements between 1800 and 4000 MC

12) Adjust the 540B Transfer Oscillator HIGH FREQ control counterclockwise to reduce the width of the zero-beat pip to a sharp line.

13) Adjust the Signal Generator frequency to position the zero-beat pip on the peak of the mode response curve.

14) Adjust the passive element frequency control to position the notch exactly on the zero-beat pip. The passive element is now set at the calibration frequency. Figure 2-16 shows the notch and pip.

15) For better accuracy, increase the Oscilloscope sweep time (SWEEP TIME/CM control) to expand the trace, and adjust the TRIGGER LEVEL and the HORIZ. POS. controls to position the trace at the center of the screen. Move the notch by adjusting the passive element frequency control to cause the notch to coincide with the zero-beat pip. Note the reading of the test instrument and compare it with the calibration frequency.

PROCEDURE FOR FREQUENCY MEASUREMENTS OF PASSIVE ELEMENTS BETWEEN 8.2 AND 12.4 KMC

- 1) Connect the equipment as shown in Figure 2-17.
- 2) Set the X382A Variable Attenuator to 10 db.
- 3) Turn on the klystron fan.
- 4) 715A Klystron Power Supply Control Settings:
MOD. SELECTOR switch to OFF.
REFLECTOR RANGE switch to OFF.
BEAM VOLTS control to approximately 380 volts.
REFLECTOR VOLTS control to 900.
- 5) Turn on all instruments and allow them to warm up for 10 minutes.
- 6) 130B Oscilloscope Control Settings:
VERT. SENSITIVITY to 0.1 VOLTS/CM.
AC/DC switch to AC.
SYNC. switch to LINE.

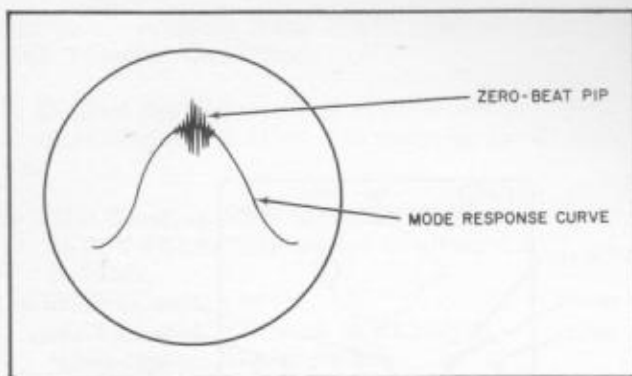

Figure 2-15. Oscilloscope Trace with Zero-Beat Pip

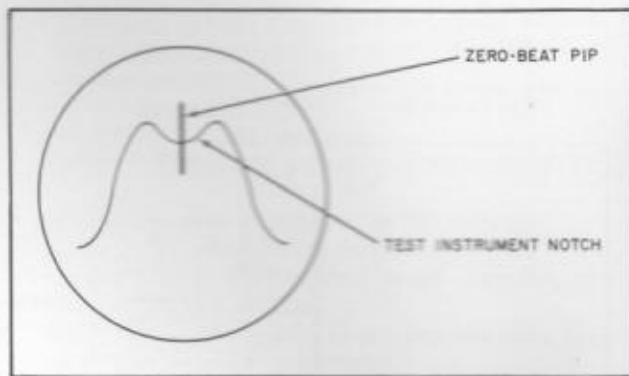

Figure 2-16. Trace on Oscilloscope when Test Instrument is at Calibration Frequency

TRIGGER SLOPE switch to +.
SWEEP TIME/CM control to 0.5 MILLISECONDS.

- 7) 524D Electronic Counter Control Settings:
FUNCTION SELECTOR switch to FREQUENCY.
FREQUENCY UNIT control to the desired gate time (usually 1 second).
DISPLAY TIME control to the desired time (usually fully counterclockwise).
- 8) 540B Transfer Oscillator Control Settings:
LOW FREQ, GAIN, and HIGH FREQ controls fully clockwise.
- 9) Select a frequency for passive element calibration and set the X-13 Klystron to approximately that frequency by adjusting the micrometer screw. (The frequency increases as the micrometer screw is turned clockwise.)
- 10) Set the 540B Transfer Oscillator FREQUENCY dial to a frequency that is a subharmonic of the test instrument calibration frequency.

Example:

If it is desired to calibrate passive element at 12 kmc, set the 540B Transfer Oscillator FREQUENCY dial to 200 mc. Twelve kmc is the 60th harmonic of 200 mc.

- 11) Set the 525B Frequency Converter MIXING FREQUENCY control to a reading from 0.1 mc to 10 mc less than the 540B Transfer Oscillator frequency setting. Set the MIXER-DIRECT-WAVEMETER switch to MIXER.
- 12) Monitor the 540B Transfer Oscillator frequency with the 524D Electronic Counter and adjust the 540B

COARSE VERNIER and FINE VERNIER controls to set the fundamental frequency exactly.

Example (Continued):

Set the 525B MIXING FREQUENCY to 190 mc and adjust the 540B Transfer Oscillator until a reading of 10 mc is obtained on the Electronic Counter. Thus, the 540B Transfer Oscillator is now set at 200 mc.

- 13) Set the X532A Frequency Meter to the calibration frequency.
- 14) Set the 715A Klystron Power Supply REFLECTOR RANGE switch to 600-900. Set the MOD. SELECTOR switch to 60 ~ .
- 15) Starting from the high end, adjust the 715A Klystron Power Supply REFLECTOR VOLTS control to obtain a sweep mode on the Oscilloscope. Adjust the MOD. VOLT. control so that the best mode pattern is obtained. Adjust the 60 ~ PHASE control for the best display.
- 16) Adjust the X382A Attenuator or the Oscilloscope SWEEP TIME/CM control to keep the trace on the Oscilloscope screen.
- 17) Adjust the X-13 Klystron micrometer screw so that the notch from the X532A Frequency Meter appears on the mode resonance curve. A zero-beat pip representing the calibration frequency should also appear on the mode. When both appear on the mode resonance curve, the Klystron is adjusted to the proper frequency.
- 18) Adjust the 715A Klystron Power Supply REFLECTOR VOLTS, MOD. VOLT. and 60 ~ PHASE controls, if necessary, to produce the trace on the

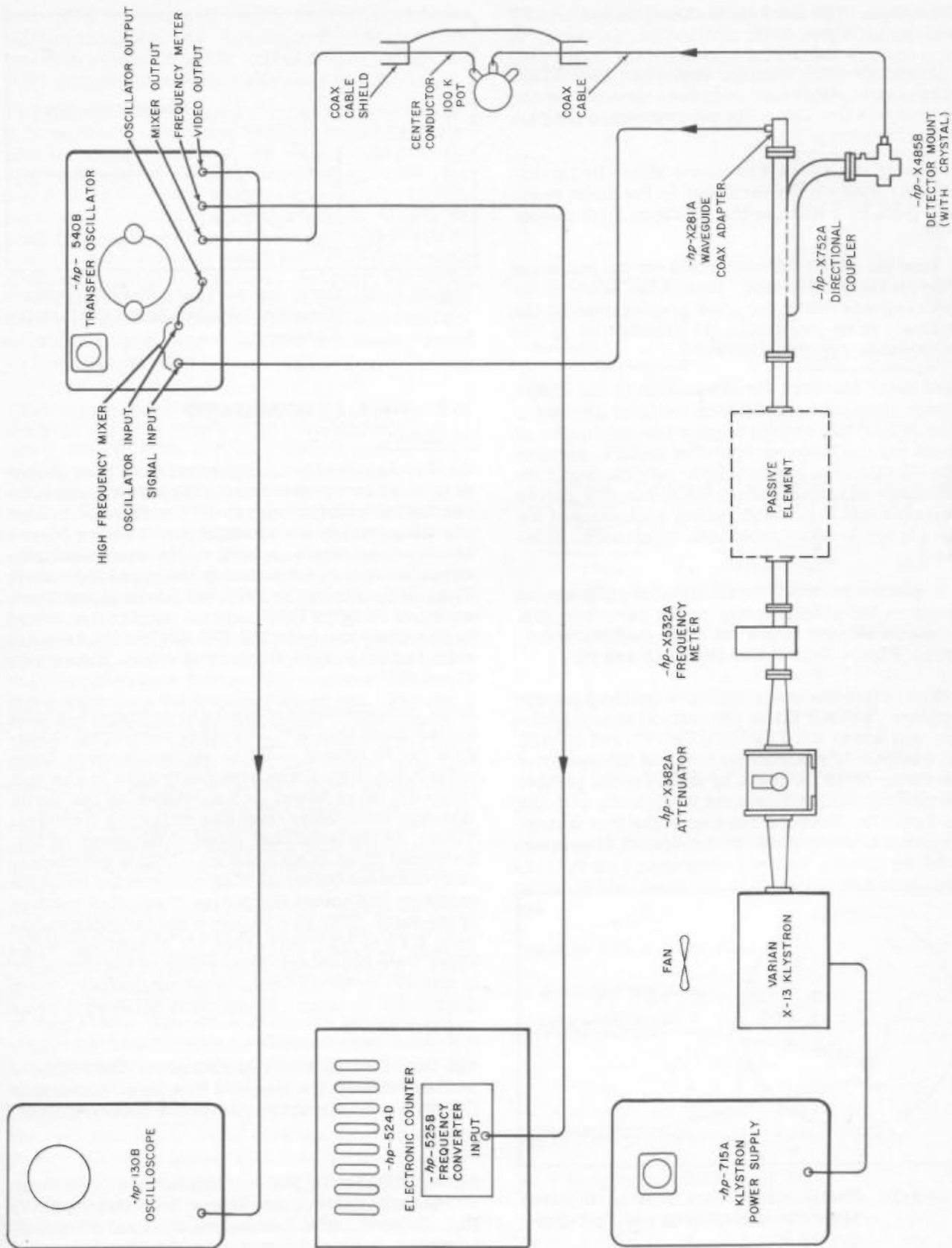

Figure 2-17. Frequency Measurement of Passive Elements from 8.2 to 12.4 KMC

Oscilloscope. The trace on the Oscilloscope should appear as in Figure 2-18.

19) Adjust the 540B Transfer Oscillator HIGH FREQ control counterclockwise to reduce the width of the zero beat to a fine line. The pip represents the calibration frequency.

20) Detune the X532A Frequency Meter by turning the knob. Position the zero beat on the mode resonance peak by adjusting the klystron micrometer screw.

21) Tune the X485B Detector Mount for the maximum display on the Oscilloscope. Reduce the height of the mode response curve for good presentation on the Oscilloscope by increasing the attenuation of the 100,000-ohm variable-resistor.

If necessary increase the attenuation of the X382A Variable Attenuator. The X382A Variable Attenuator or the 540B GAIN control adjusts the amplitudes of both the pip and mode curves. The variable resistor or the X485B tuning control adjusts only the amplitude of the mode response curve. (The resistor can be eliminated and the X485B tuning control used for mode response curve amplitude adjustment, if desired.)

22) Adjust the passive element frequency adjustment to position the notch exactly on the zero-beat pip. The passive element is now set at the calibration frequency. Figure 2-19 shows the notch and pip.

23) For better accuracy increase the Oscilloscope sweep time (SWEEP TIME/CM control) to expand the trace, and adjust the TRIGGER LEVEL and HORIZ. POS. controls to position the trace at the center of the screen. Move the notch by adjusting the passive element frequency adjustment to coincide with the zero-beat pip. Note the reading of the test instrument and compare it with the calibration frequency.

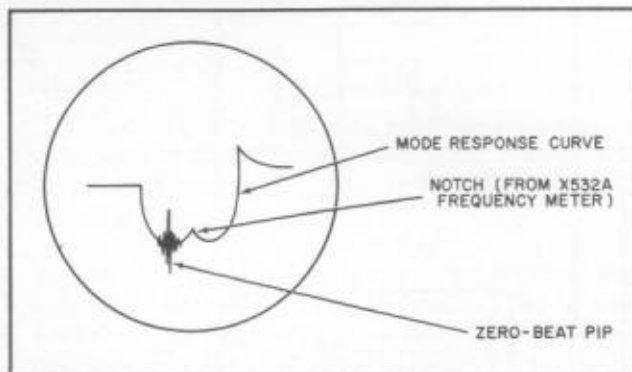

Figure 2-18. Oscilloscope Trace Showing Klystron Mode Response Curve and Test-Frequency Pip

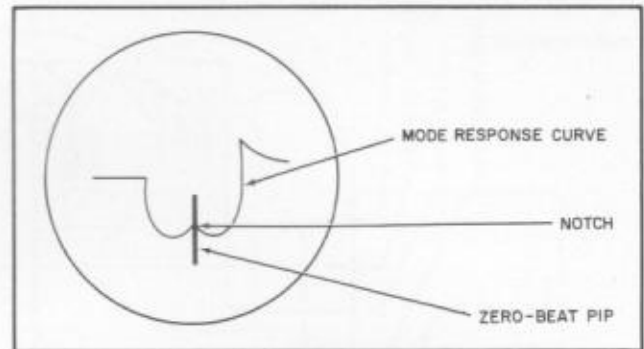

Figure 2-19. Oscilloscope Trace Showing Passive Element Adjusted to the Calibration Frequency

2-5 TIME COMPARISONS

GENERAL

As time is one of the independent quantities chosen as a basis for measurement, the unit of time must remain constant, be physically realizable to high precision, and be permanently available for observation. The orbital motion of the earth about the sun provides a suitable time scale called Ephemeris Time (ET). Hence, in 1956, the International Committee on Weights and Measures adopted the second as the "fraction $1/31,556,925.9747$ of the tropical year for January 0, 1900 at 12 hours Ephemeris Time."^{*}

Some measurements of time are expressed in time scales other than ET. All other measuring standards can be related to ET by various factors. Mean solar time, which was commonly used in the past (and still is) is based on the rotation of the earth. Recently mean solar time was defined as Universal Time. As the rotational speed of the earth varies, Universal Time is not constant. UT0 is astronomically observed Universal Time uncorrected for polar variation and annual fluctuation of speed of rotation of the earth. UT1 is UT0 corrected for polar variation, UT2 is UT1 corrected for annual variation. Other time scales are determined by the frequency of quartz- or atomic-controlled oscillators. Time determined by atomic standards is believed to be as constant as ET.

The United States Frequency Standard (USFS) makes available through the Standard Frequency Broadcasts (WWV) a provisional time scale for measurements.

^{*}J. M. Richardson, National Standards of Time and Frequency in the United States, NBS Report 6077, U. S. Department of Commerce, National Bureau of Standards, Boulder Laboratories, Boulder, Colorado.

The USFS is compared with atomic standards for highest accuracy. As of January 1, 1960 the USFS has been corrected to ET instead of UT. Hence, the WWV broadcasts are also corrected to ET.

For high accuracy frequency or time measurements, it is necessary to compare the local working standard with the national standard. As comparisons are usually made against signals transmitted by radio, they are limited to an accuracy of 2 to 3 parts in 10^8 , because of transmission path variations. This is insufficient for frequency comparisons with available commercial oscillators which have stabilities of the order of 1 part in 10^9 per day. However, the signal drift caused by these variations in transmission path averages out over periods of time. Therefore, accurate frequency determinations are usually based on time comparisons.

Time comparisons with radio transmissions may be made as shown in Figure 2-20. Transmissions from WWV, WWVH, MSF, JJY, or any other station transmitting precise time signals, are picked up by the receiver, and the received time ticks are connected to the vertical plates of the Oscilloscope. The one-per-second pulses of the transmitted time signals are used for comparison. They are usually amplitude modulated and consist of an integral number of audio-frequency cycles. The WWV tick, for example, is 5 cycles at 1000 cps, and the WWVH tick is 6 cycles at 1200 cps. An -hp- 113AR Frequency Divider and Clock and a 120A Oscilloscope are used to resolve the time difference between the received time pulse and a pulse from the frequency under test. The signal from the standard is applied to the 113AR, where it is converted to 1-second ticks. These ticks trigger the Oscilloscope sweep. Hence any change in the frequency under test shifts the trace on the Oscilloscope. As the duration of the standard time signal pulse (tick) is 5 milliseconds (or 5 parts in 10^8 per day) this technique is necessary if a daily measurement accuracy of better than $5/10^8$ is to be obtained.

At the beginning, one-per-second ticks from WWV and from the 113AR may be as much as 1/2 second apart. If a total sweep time of 1 second or more is used, the WWV tick can be located with reference to the tick from the 113AR by using the phase shifter in the 113AR. The phase shifter is adjusted to decrease the time difference between the two ticks, and the WWV tick moves toward the beginning of the Oscilloscope trace. By successive adjustment of the phase shifter and of the Oscilloscope sweep speed, the two ticks can be made very nearly coincident in time. The phase shifter dial is calibrated in increments of 10 microseconds. Once coincidence between the ticks has been established, the reading of the phase shifter dial is logged as a reference for future tests.

The drift of the test frequency standard may be found by observing the position of the WWV tick at some later time. The tick may be shifted with the phase shifter to the original position on the Oscilloscope screen. The drift in time is then the difference of the phase shifter dial readings.

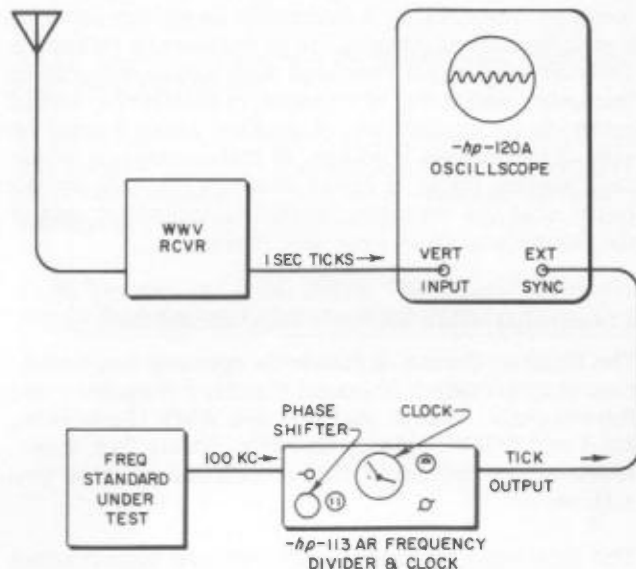

Figure 2-20. Time Comparison with
-hp- Model 113AR

The computation of average frequency by time comparisons may be explained by the following equations:

$$f_{\text{ave}} = f_0 \frac{t}{T} \quad (1)$$

where f_0 is the nominal frequency of the oscillator, i.e., 100 kc; t represents the time interval as determined by the clock; and T is the correct time interval.

Equation (1) can be written as:

$$\begin{aligned} f_{\text{ave}} &= f_0 \frac{(T + \Delta t)}{T} \\ &= f_0 \left(1 + \frac{\Delta t}{T} \right) \end{aligned}$$

where Δt is the difference between T and t .

As T is approximately equal to t

$$f_{\text{ave}} \approx f_0 \left(1 + \frac{\Delta t}{t} \right) \quad (2)$$

Hence, the average frequency can be expressed in terms of readily available data. If drift is uniform, f_{ave} represents the instantaneous frequency for the center of the period.

Several factors must be considered for the proper operation of a precision standard. The equipment must be installed in a favorable environment with a standby power supply. It is necessary to keep a daily record of all readings and measurements of frequency and time, of changes in standards, and of methods or equipment. A weekly record must be kept of instrument readings, of battery charge levels and charging rates, of meter readings for each switch position of the standard oscillator and clock, and of the temperatures of oven and room.

STANDARD TIME SIGNAL TRANSMISSIONS

The National Bureau of Standards operates two broadcast stations which transmit standard frequency and time signals. These stations are WWV (Beltsville, Md.) and WWVH (Maui, Hawaii). Table 2-3 summarizes the operating characteristics of these two stations.

The following technical services are broadcasted daily by Stations WWV and WWVH:

- 1) Standard Radio Frequencies

- 2) Standard Audio Frequencies
- 3) Standard Time Intervals
- 4) Time Signals
- 5) Radio Propagation Forecasts

Additional information concerning the technical services of WWV and WWVH may be obtained from the National Bureau of Standards, Boulder Laboratories, Boulder, Colorado.

ACCURACY

Time comparison to 10 microseconds yields accuracy of approximately 1 part in 10^{10} if two checks are made 24 hours apart. Readings taken 10 days apart can yield accuracy in the order of 1 part in 10^{11} ; tests at 100-day intervals afford comparison accuracy of approximately 1 part in 10^{12} , etc. After each test, the difference between the phase shifter reading and the reference reading is plotted. Time differences may be converted to frequency differences, and a plot of frequency referred to WWV can be made.

When both the WWV and WWVH seconds pulses are used, one of the two signals must be selected when time measurements are made for frequency determination. The signal can be selected by a directive

TABLE 2-3. WWV AND WWVH OPERATING CHARACTERISTICS

Station	Frequency		Radiated Power (KW)	Transmitted Accuracy (Carrier)	Normal Stability at Transmitter
	Carrier (mc)	Audio (cps)			
WWV	2.5	440* & 600	1.0	±5 parts in 10^{10}	1 part in 10^{10}
	5.0		8.0		
	10.0		9.0		
	15.0		9.0		
	20.0		1.0		
	25.0		0.1		
WWVH	5.0	440* & 600	2.0	± 5 parts in 10^9	1 part in 10^9
	10.0		2.0		
	15.0		2.0		

* Standard Musical Pitch of "A above Middle C"

receiving antenna or by selecting the proper pulses. At certain locations it is necessary to differentiate between pulses received from both directions around the earth. For example, at Maui, pulses are consistently received in the morning from WWV on 15 and 20 mc by paths going both directions around the earth, with delays of approximately 0.027 and 0.113 second. Often, for brief periods, pulses received over the longer path are stronger than those received over the shorter path, because of differences in absorption. Checking a well stabilized standard clock helps to discriminate against undesired signals as the expected time of arrival can be known to a few milliseconds. It is desirable to make measurements with optimum reception conditions and a stable ionosphere.

2-6 REFERENCES

LaThare N. Bodily and Leonard Cutler, 524D Elec-

tronic Counter, "-hp- Journal," vol. 10, Nos. 3 and 4.

Dexter Hartke, Frequency Measurements, "-hp- Journal," vol. 6, No. 12.

Dexter Hartke, "Precision Time Measurements."

E. L. Ginzton, "Microwave Measurements," McGraw-Hill, New York, 1957.

J. M. Richardson, National Standard of Time and Frequency in the United States, NBS Report 6077, U. S. Department of Commerce, National Bureau of Standards, Boulder Laboratories, Boulder, Colo.

F. E. Terman and J. M. Pettit, "Electronic Measurements," McGraw-Hill, New York, 1952.

SECTION III ATTENUATION

3-1 GENERAL DESCRIPTION

ATTENUATION

Attenuation is defined as the ratio of power leaving a network to power entering a network (see Figure 3-1) when both the input and the output are perfectly matched to the source and the load respectively. Hence no mismatch occurs at either terminal of the network. The attenuation is commonly expressed in decibels by:

$$\alpha_a = 10 \log \frac{P_2}{P_1}$$

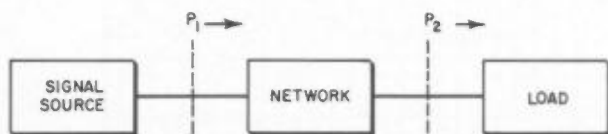

Figure 3-1. Power-Ratio Variables

INSERTION LOSS

Insertion loss is defined as the ratio of power absorbed by a load before and after the network is inserted in the system. (See Figure 3-2.) For meaningful measurements, the load and source are tuned to match the line so that unity SWR exists.

The insertion loss in decibels is defined as:

$$\alpha_i = 10 \log \frac{P_2}{P_1}$$

The insertion loss consists of two factors: the attenuation of the network; and the mismatch losses occurring because the impedances at the source-network and load-network junctions are not matched.

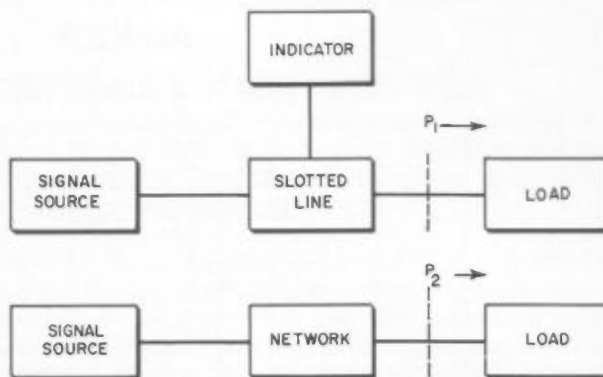

Figure 3-2. Insertion-Loss Variables

MISMATCH LOSS

Mismatch loss is defined as the difference between the power which would be absorbed by a network if it were perfectly matched to the source and the power which is absorbed by the network with existing network impedance. (See Figure 3-3.)

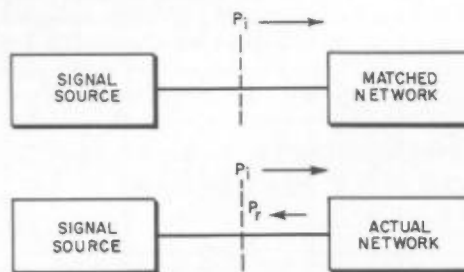

Figure 3-3. Mismatch-Loss Variables

In decibels, the loss is expressed by the formula:

$$\alpha_m = 10 \log \frac{P_i - P_r}{P_i}$$

Mismatch loss occurs whenever the impedances at a junction are not matched. If the network has an input impedance that is the complex conjugate of the output of the source, all of the incident power is absorbed, and no loss occurs.

The mismatch losses can easily be determined from the SWR's of the source and load. Figure 3-4 contains a graph showing losses for various SWR's. The loss in db is shown on the diagonal lines. Hence, for a

source SWR of 1.2 and a load SWR of 1.5, the possible maximum and minimum losses are 0.37 db and 0.053 db respectively. If the source or load has unity SWR, the loss can be uniquely determined. If neither does, a range of loss exists depending upon the phase of the reflection coefficients. If they add in phase, a maximum SWR results at the junction, producing a maximum loss. If they subtract, a minimum SWR occurs, producing a minimum loss.

POWER LOSS CURVES

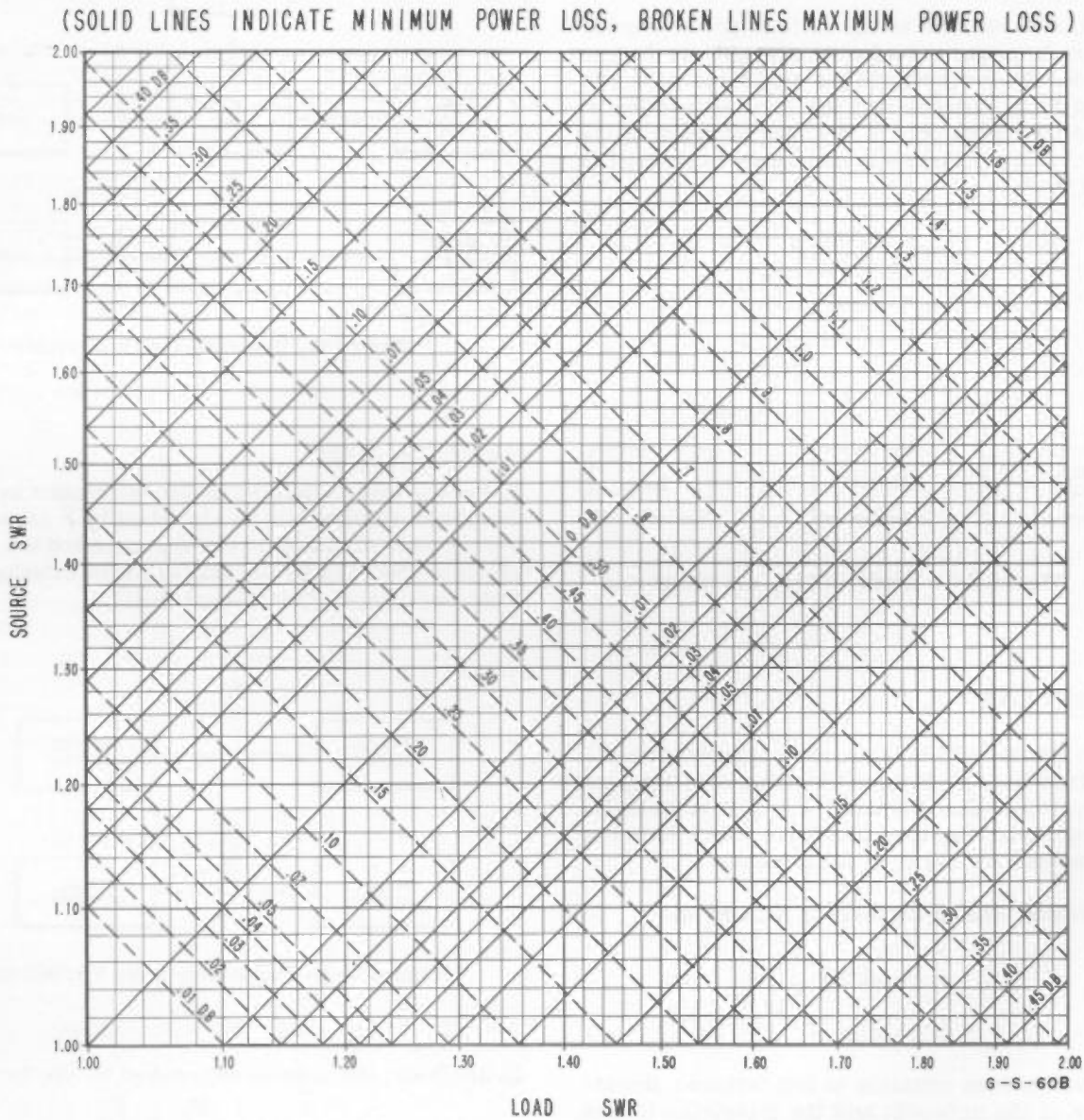

Figure 3-4. Mismatch-Loss Curves

Sometimes it is desirable to mask out the effects of a high load or source SWR for matching purposes. A pad in series with the load or source provides SWR reduction. Consider the example in Figure 3-5.

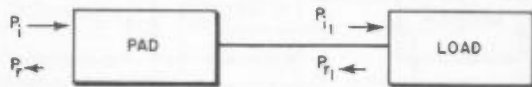

Figure 3-5. SWR-Reduction Variables

The incident power into the pad is P_i . An attenuated amount of this power is received at the load, and part is reflected. The reflected power is also attenuated passing through the pad. The resulting SWR looking into the pad and load is much less than that of the load alone. If the pad has a negligible SWR, the effective SWR of the combination can be calculated from the formula:

$$SWR = \frac{R (SWR_L + 1) + (SWR_L - 1)}{R (SWR_L + 1) - (SWR_L - 1)}$$

where

SWR_L = SWR of load or source

R = Ratio of power input to power out of attenuator

$$= \text{Antilog } \frac{\alpha}{10}$$

If a 10-db pad is placed in series with a load having a SWR of 3, the resulting SWR of the combination (see Figure 3-6) is:

$$\begin{aligned} SWR &= \frac{10 (3 + 1) + (3 - 1)}{10 (3 + 1) - (3 - 1)} \\ &= \frac{40 + 2}{40 - 2} \\ &= 1.10 \end{aligned}$$



Figure 3-6. SWR-Reduction Calculations

A pad is frequently inserted between a generator and a network to insure that the effective generator SWR is small.

Absolute and relative attenuation are terms frequently referred to in attenuation measurements. Absolute attenuation is the total amount of attenuation presented by a network and is illustrated by such devices as fixed pads or lengths of cable. Relative attenuation is the change of attenuation as found in such devices as variable attenuators. For example, a variable attenuator might be calibrated from 0 to 50 db. The amount of relative attenuation can be varied from 0 to 50 db. The absolute attenuation of the attenuator also includes the insertion loss. Therefore, the absolute attenuation might be 21 db, instead of 20 db as indicated on the dial.

ATTENUATION MEASURING METHOD

Several methods of measuring the attenuation of a network are used, including the insertion method, substitution method, cavity-resonant method, and scattering-coefficient method.

Of the described methods the substitution method is commonly employed for high-accuracy measurements of fixed or variable attenuators. The attenuator under test is compared with a precision attenuator. This method is used more often than the insertion method for high accuracy measurements, as the output amplifier and indicator are always operated at the same level. Therefore, any nonlinearity in the amplifier or indicator system is not reflected in the accuracy of the measurements.

In this section two systems are described. One uses a linear detector, standard attenuator, receiver, and indicator; the other system uses a square-law detector, standard audio attenuator, amplifier, and indicator. The total amount of attenuation that can be measured is the principal difference between the two systems. The systems have comparable accuracies. The linear detecting system measures approximately twice as much attenuation as the square-law detector system. However, it requires more equipment.

3-2 ATTENUATION MEASUREMENTS WITH SQUARE-LAW DETECTION

GENERAL

A convenient attenuation measuring system employs a source, modulated by 1000 cps, a square-law detector, a precision audio attenuator, and a tuned indicator. The attenuation measuring system is connected as shown in Figure 3-7. The -hp- 415B Standing Wave Indicator can be used as the precision attenuator and indicator.*

* The Weinschel BA-5 is also suitable.

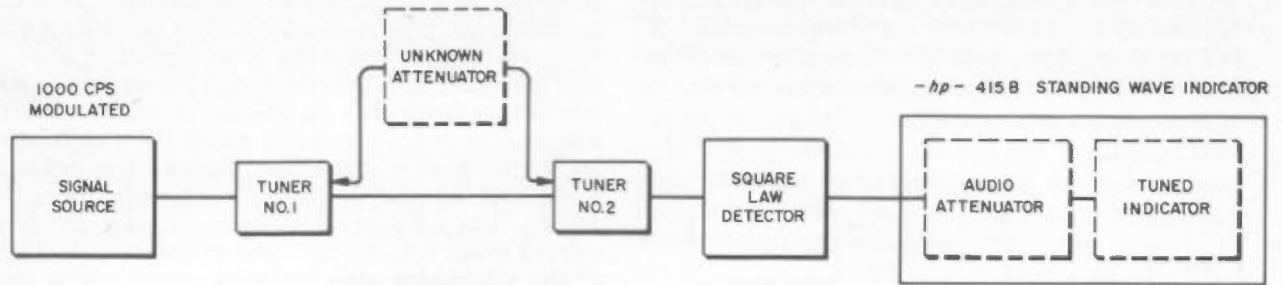

Figure 3-7. Single-Channel Attenuation-Measuring System Using Square-Law Detection

Attenuation is measured by substituting attenuation of the unknown for the attenuation of the precision attenuator. The most commonly used detector element, because of its desirable characteristics, is the barretter. The barretter is supplied by a constant-current source. As the change in resistance of the barretter is proportional to the input rf level, the audio voltage developed by the barretter element is proportional to the input power. This voltage is attenuated, amplified, and displayed on the 415B. The bolometer current is selected so that the barretter is operating over the most linear portion of the square-law region. The rf power level, 415B attenuator, and amplifier gain are adjusted for an indication on the 415B. The source-modulating frequency is also adjusted for the center frequency of the 415B (1000 cps). The source power must not be set so high as to drive the barretter out of its square-law region. The amount of source power that can be used depends upon each individual barretter.

The probe of the first tuner is completely withdrawn, as it is not used in the initial setup. The second tuner is used to match the barretter mount to the line. The tuner is adjusted for maximum indication on the 415B. Next, the attenuator under test is inserted between the two tuners. The attenuation of the 415B audio attenuator is decreased to obtain an upscale reading on the 415B. The first tuner is adjusted to match the unknown attenuator to the system.

NOTE

For insertion-loss measurements, the tuners are adjusted so that unity SWR exists when looking into the generator and into the load.

The attenuation of the instrument under test is then computed as the difference between the initial and final 415B readings.

As the audio-frequency voltage developed across the barretter is proportional to the rf input power, a 10-db reduction in the rf level causes a 20-db reduction

in the audio-frequency level. So if, for example, a 10-db pad is measured, 20 db of audio attenuation must be removed in order to obtain the same indicator level. Units specifically designed for attenuation measurements with square-law detectors have an audio attenuator calibrated so that a 10-db reduction in the rf level into the barretter is shown as a 10-db change on the audio attenuator. The 415B Standing Wave Indicator is calibrated in this fashion.

This system of measuring attenuation can be used over a wide frequency range. It has been used successfully between 10 megacycles and 40 kmc. In fact, it may be used wherever suitable barretters and barretter mounts are available.

The range of attenuation that can be measured in one step depends upon the linearity of the barretter and the noise level. The maximum range of most barretter-and-amplifier combinations is approximately 30 db. At this range of operation the error is generally no more than 0.05 db. 20 db of attenuation can easily be measured with these systems. Measurements above 20 db, however, must employ certain precautions so that the square-law region of the barretter is not exceeded. The total amount of attenuation that can be measured is determined by the available source power. The procedure for measuring the attenuation of variable attenuators consists of measuring the attenuation in steps of 20 db or less.

Another method which employs a square-law detector is the dual-channel system for attenuation or insertion-loss measurements. This system,* developed by Weinschel Engineering, eliminates inaccuracy in measurement caused by source instability. Hence, it may be used where source instability limits the accuracy of the measurement. The system diagram is shown in Figure 3-8.

* B. O. Weinschel, Dual Channel Insertion Loss Test Set, Application Note No. 4, Weinschel Engineering Co., Inc.

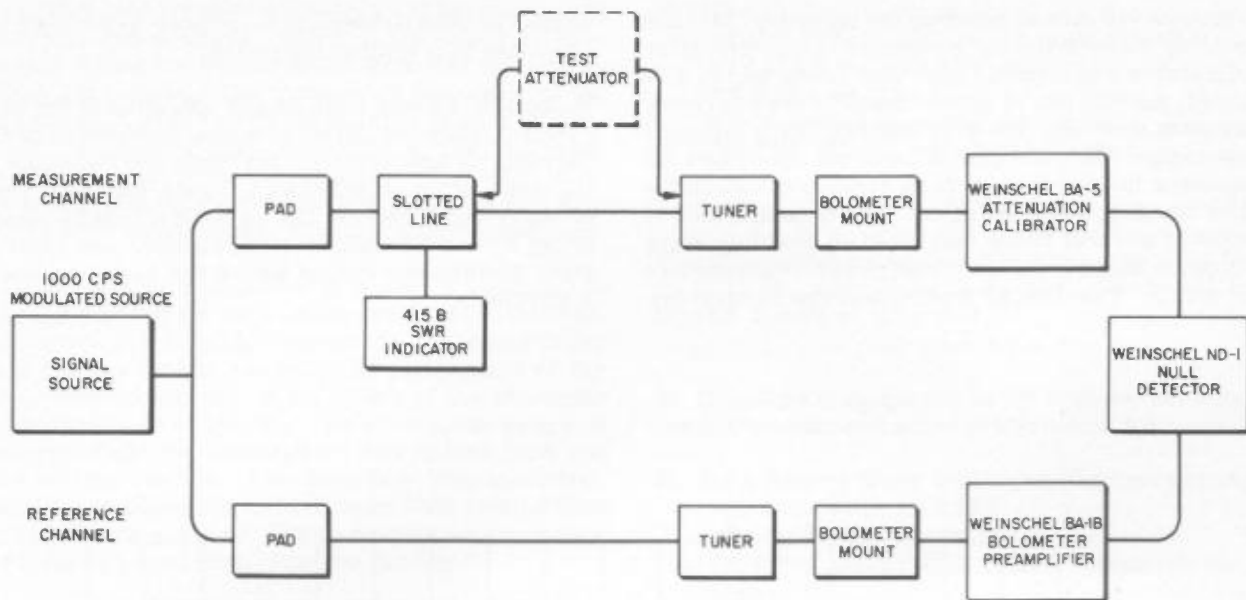

Figure 3-8. Dual-Channel Setup for Insertion-Loss Measurements

An rf source of the proper frequency is square-wave modulated at a frequency of 1 kc and is divided into two channels: the measurement channel and the reference channel. The two rf signals derived from the same generator are detected in two bolometers which are operated in their square-law region; i.e., the voltage at the modulation frequency developed across the bolometer is proportional to the rf power absorbed by the bolometer. The 1-kc signals from the bolometers are then amplified and applied to the Differential Null Detector.

To measure insertion loss, the precision audio attenuator in the BA-5 Attenuation Calibrator is first set to include slightly more attenuation than the expected insertion loss of the unit to be tested or calibrated. The gain in the reference channel and the phasing adjustments on the Differential Null Detector are adjusted to produce a null reading on the Null Detector. The unit under test is then inserted in the measurement channel as shown in the block diagram. Audio attenuation is removed until a null indication is again obtained. The amount of audio attenuation removed is a measure of the insertion loss of the unit under test. The output of the measurement channel is not necessarily returned to the same level as before insertion of the unit under test, but rather to a value to produce a null reading on the ND-1. If the rf-source output has drifted since the first null adjustment, the reference-channel output has changed by a proportionate amount, and the measurement-channel output required to produce a null is automatically compensated.

ACCURACY

The accuracy of a measurement in a single-channel system depends upon several factors. These include the square-law region of the barretters, frequency and amplitude stability of the source modulation, proper matching between the system and attenuator, and the accuracy of the precision audio attenuator. The amplifier and indicator usually introduce negligible error, as they are always operated at nearly the same power level.

The barretter is usually the largest single source of error. At higher power levels, deviation from true square-law operation limits the total amount of attenuation that may be measured. Deviation occurs because at high power levels barretters dissipate heat through conduction and radiation as well as by convection. This deviation becomes more important as the operating temperature of the barretter increases. The audio frequency must be low enough to permit the barretter to follow the modulation envelope. The peak temperature in the barretter is then a function of the peak power, not the average power. The resulting deviation from square law is then a function of the peak power. The square-law region of the barretter can be determined by measuring a fixed attenuator repeatedly while raising the rf power level. Any deviations from the square-law response can be determined. The barretter can then be operated in a square-law region.

For example, a barretter is connected to a generator through a 10-db pad and the generator output adjusted

to provide -50 dbm of power to the barretter. A 415B Standing Wave Indicator connected to the barretter indicates a reading of -55. The 10-db pad is removed, so that the rf power input to the barretter increases by 10 db. The 415B Standing Wave Indicator now reads -45. The pad is inserted again and the generator level increased for a reading of -45 on the 415B Standing Wave Indicator. The measurement is repeated several times and the 415B Standing Wave Indicator and barretter input-power readings are recorded. The data is plotted and the square-law

region is then determined. Figure 3-9 shows the response of a typical barretter.

Noise sets a lower limit on the operation of the barretter. When the detected audio modulation of the barretter is approximately ten times the magnitude of the noise, error is introduced. Again, the lower limit of barretter operation can be determined by measuring a fixed attenuator using smaller and smaller input powers and noting where the error becomes appreciable.

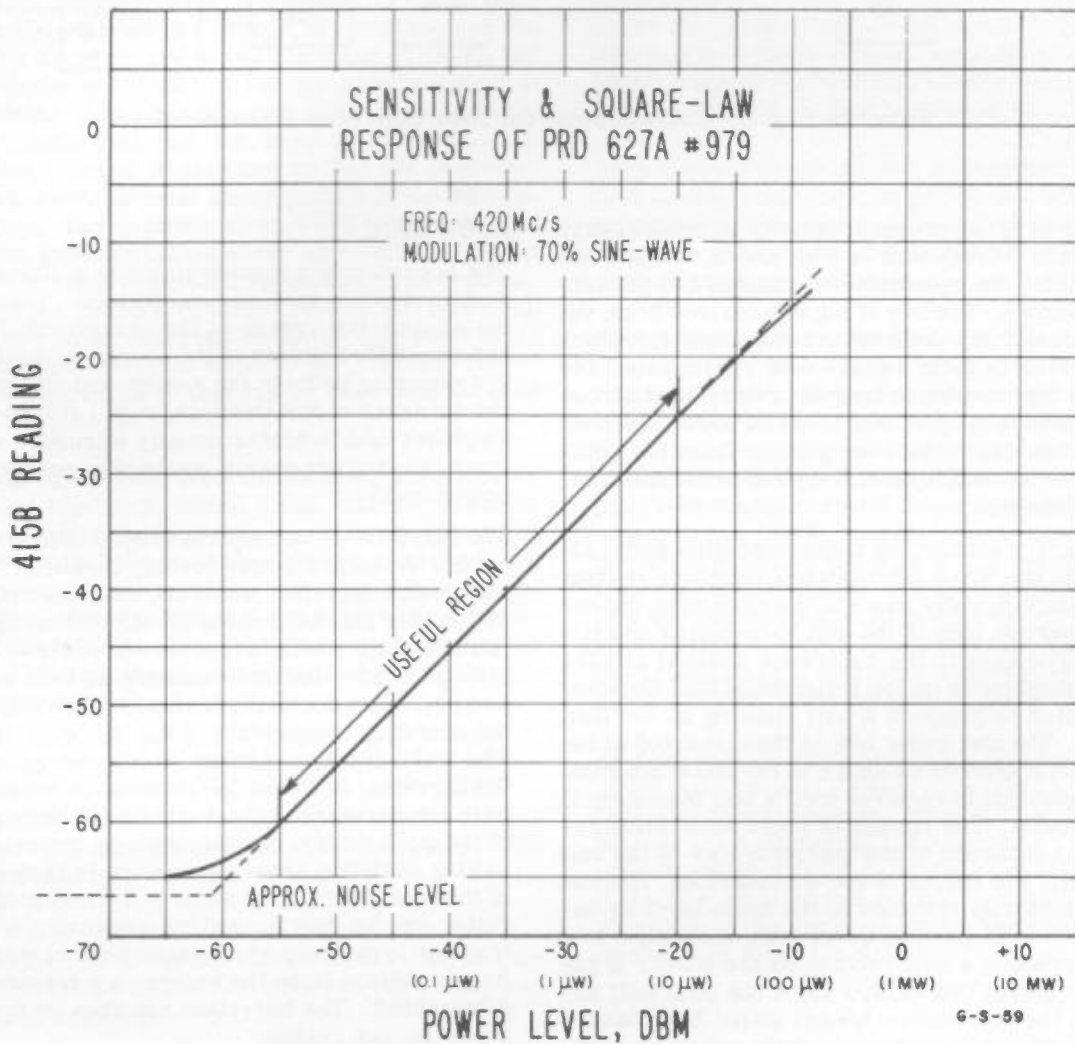

Figure 3-9. Sensitivity and Square-Law Response of PRD 627A #979

Amplitude and frequency instability of the source are also sources of error. Drift in amplitude or frequency during the measurement time may be recorded as attenuation. The modulation frequency of the source must also be kept as nearly constant as possible. If the modulation frequency varies, the reading of the tuned voltmeter changes. Normally, voltmeters are sharply tuned, and any frequency deviation of the input signal causes a variation on the indicator.

For attenuation measurements it also is important to carefully match the attenuator under test to the line. Any mismatch existing between the attenuator under test and the line is recorded as attenuation of the attenuator under test. If the SWR's of the attenuator under test and of the line are known, the range of mismatch can be computed or determined from the power-loss curves. For insertion-loss measurements it is important to have unity SWR looking back to the source and load. NBS provides measurement of insertion loss at its Boulder facility.

The precision audio attenuator, used as the standard, is generally of sufficient accuracy to have negligible effect upon the total accuracy of the system. As precision resistors are manufactured, a very accurate audio attenuator can be constructed. The attenuator and indicator of the 415B can be calibrated together with a ratio transformer. The procedure is described in Application Note No. 39.

EXAMPLE: ATTENUATION MEASUREMENTS IN COAX BETWEEN 800 AND 4000 MC

Range

One-step Attenuation - 30 db maximum.
Total Attenuation - 35 to 40 db for 0-dbm source.

Accuracy

Fixed Attenuation - ± 0.2 db or 1% of measured attenuation in db, whichever is greater.
Variable Attenuation - ± 0.1 db or 1% of measured attenuation in db, whichever is greater.

The accuracy specification represents the limit to which the National Bureau of Standards certifies attenuators.

Preliminary Procedure

1) Connect the equipment as shown in Figure 3-10. For variable attenuators insert the attenuator under test between the Slide Screw Tuners. Do not connect the 415B Standing Wave Indicator to the PRD 627A Bolometer Mount.

2) Set the Signal Generator FM-CW-OFF switch to OFF.

- 3) 415B Control Settings:
INPUT SELECTOR switch to BOLO 200 Ω .
BOLO BIAS CURRENT switch to LOW.
RANGE switch to 30.
GAIN control to nearly maximum.
METER SCALE switch to NORMAL.

NOTE

For attenuation measurements from 0 to 2 db, from 10 to 12 db, from 20 to 22 db, etc., set the METER SCALE switch to EXPAND.

- 4) Connect all equipment to 115V ac power, turn on the equipment, and allow ten minutes for warmup.
- 5) 211A Square Wave Generator Control Settings:
RANGE switch to X100.
FREQUENCY dial to 10.
OUTPUT AMPLITUDE control completely clockwise.
- 6) Connect the PRD 627A Bolometer Mount to the 415B.
- 7) For relative attenuation measurements, set the attenuator under test at a nominal value (reference point). This reference point is the value to which all readings are referred.
- 8) Signal Generator Control Settings:
SIGNAL FREQUENCY dial to the test frequency.
ZERO SET control for a ZERO SET indication on the meter.
FM-CW-OFF switch to EXT NEG.
OUTPUT ATTEN control for an upscale reading on the 415B.

CAUTION

Do not exceed 0 dbm (1 mw) into the PRD 627A Bolometer Mount. Excessive power will burn out the bolometer.

- 9) Adjust the 211A Square Wave Generator FREQUENCY control for a maximum indication on the 415B.
- 10) Withdraw the probe of Slide Screw Tuner No. 1 (Hewlett-Packard Model H01 872A). Tune Slide Screw Tuner No. 2 for a maximum indication on the 415B.

NOTE

For insertion-loss measurements, adjust the Tuners for unity SWR looking into the detector and the generator. Refer to Paragraph 4-3 for procedure.

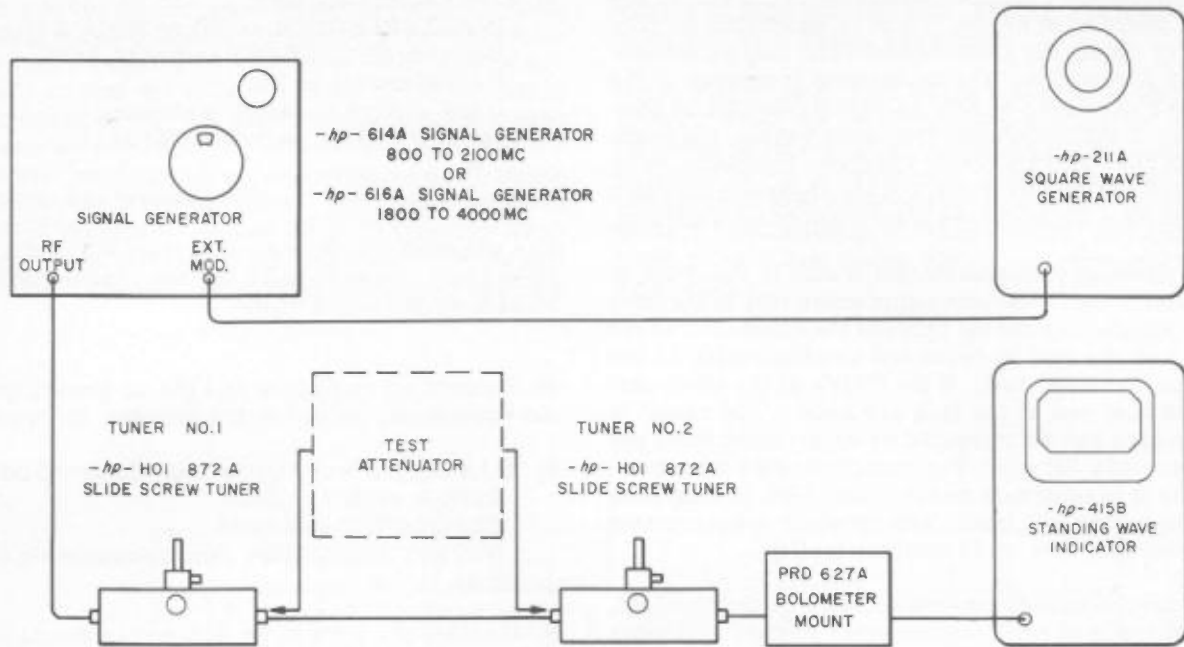

Figure 3-10. Absolute Attenuation Measurements over the Frequency Range of 800 to 4000 MC

Procedure for Measuring Absolute Attenuation

- 1) Adjust the Signal Generator Attenuator and 415B GAIN controls for a full-scale 415B meter reading ("0" on the DB or EXPANDED DB scale).
- 2) Insert the attenuator under test between the two Slide Screw Tuners.
- 3) Adjust the 415B RANGE switch if necessary for an upscale reading.
- 4) Tune both Slide Screw Tuners for a maximum reading on the meter.

NOTE

For insertion-loss measurements, do not adjust the Tuners.

-
- 5) The attenuation of the attenuator under test is the reading on the 415B meter plus the change in the 415B RANGE switch setting.

Procedure for Measuring Relative Attenuation (0 to 20 DB)

- 1) Adjust the Signal Generator attenuator and 415B GAIN controls for a full-scale 415B meter reading ("0" on the DB or EXPANDED DB scale).
- 2) Set the attenuator under test to the first calibration point. (This step must be 20 db or less.)

- 3) Adjust the 415B RANGE switch if necessary for an upscale reading.
- 4) The difference in attenuation between the reference setting and this setting of the attenuator under test is the reading on the 415B meter plus the change in the 415B RANGE switch setting.
- 5) To calibrate the attenuator under test at more points, set the attenuator under test to the next calibration point and repeat the attenuation measurement.

Procedure for Measuring Relative Attenuation Above 20 DB

- 1) Measure the first 20 db as above and note the final 415B meter reading.
- 2) Decrease the 415B RANGE switch setting by 20 db (two 10-db steps).
- 3) Increase the Signal Generator output by adjusting the OUTPUT ATTEN control for the 415B meter reading noted in step 1.
- 4) Increase the attenuation of the attenuator under test to the next calibration point.
- 5) The relative attenuation of the attenuator under test (the difference between the reference setting and this setting) is the reading on the 415B meter plus the change in the 415B RANGE switch setting plus 20 db.

EXAMPLE: ATTENUATION MEASUREMENTS IN COAX BETWEEN 8.2 AND 12.4 KMCRange

One-step Attenuation - 30 db.
Total Attenuation - 60 db with +20-dbm source.

Accuracy

Fixed Attenuation - ± 0.2 db or 1% of measured attenuation in db, whichever is greater.
Variable Attenuation - ± 0.1 db or 1% of measured attenuation in db, whichever is greater.

The accuracy specification represents the limit to which the National Bureau of Standards certifies attenuators.

Preliminary Procedure

- 1) Connect the equipment as shown in Figure 3-11. For relative attenuation, insert the attenuator under test between the Slide Screw Tuners. Do not connect the 415B Standing Wave Indicator to the X485B Detector Mount at this time.
- 2) 715A Klystron Power Supply Control Settings:
REFLECTOR RANGE switch to 600-900.
MOD. SELECTOR switch to OFF.
BEAM VOLTS control to approximately 380.
REFLECTOR VOLTS control fully clockwise.
MOD. VOLT. control partially clockwise.
- 3) 415B Control Settings:
INPUT SELECTOR switch to BOLO 200 Ω .

BOLO BIAS CURRENT switch to LOW.
RANGE switch to 30.
GAIN control to nearly maximum.
METER SCALE switch to NORMAL.

NOTE

For attenuation measurements from 0 to 2 db, from 10 to 12 db, from 20 to 22 db, etc., set the METER SCALE switch to EXPAND.

-
- 4) Set the X382A Variable Attenuator to 20 db.
 - 5) Connect the equipment to 115V ac power. Turn on the klystron fan. Turn on all equipment and allow it to warm up for ten minutes.
 - 6) Connect the X485B Detector Mount to the 415B.
 - 7) For relative attenuation measurements, set the test attenuator under test to a nominal value (reference point). This reference point is the value to which all readings are referred.
 - 8) Set the X-13 Klystron micrometer control to the test frequency.
 - 9) Set the 715A Klystron Power Supply MOD. SELECTOR control to 1000 \sim . Decrease the REFLECTOR VOLTS control setting until the Klystron starts oscillating, as indicated by a jump in the cathode current. If necessary, switch the REFLECTOR RANGE switch to 300-600. If necessary, change the X382A Variable Attenuator setting to obtain an upscale reading on the 415B.

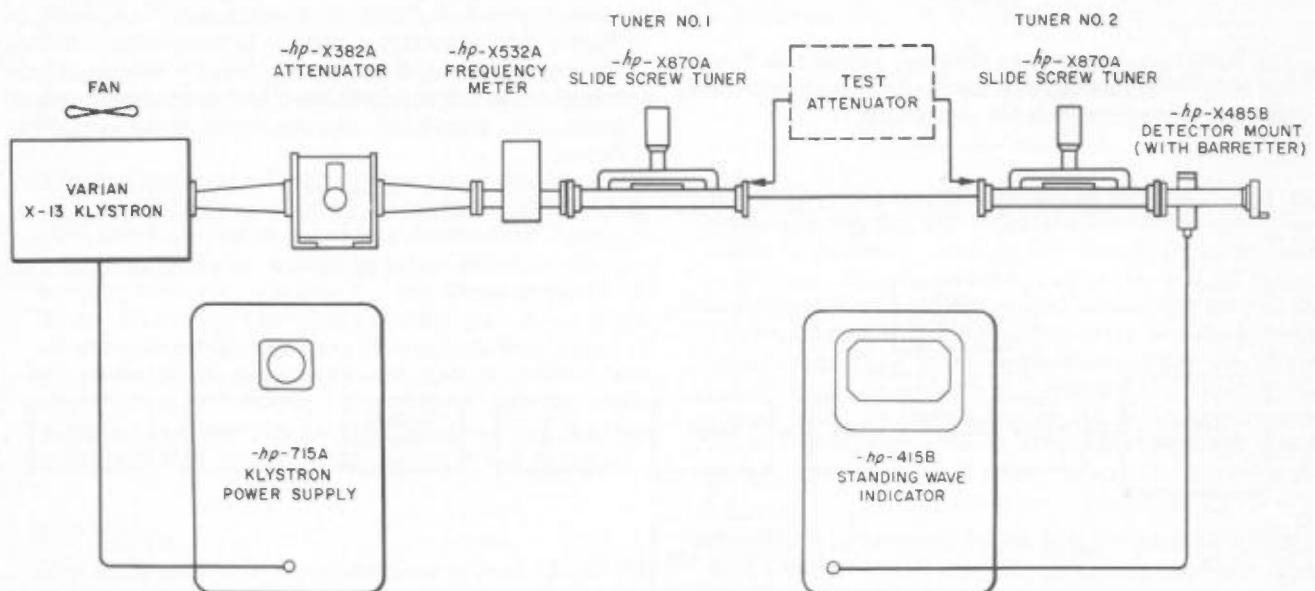

Figure 3-11. Attenuation Measurements over the Frequency Range of 8.2 to 12.4 KMC

CAUTION

Do not reduce the attenuation of the X382A Variable Attenuator below 10 db, or the barretter might be destroyed. For highest accuracy, operate the X485B with rf power input less than 0.2 mw.

10) Adjust the 715A MOD. FREQ. control for a maximum reading on the 415B, adjusting the X382A as necessary.

11) Adjust the 715A REFLECTOR VOLTS and MOD. VOLT. controls for a maximum reading on the 415B, adjusting the X382A as necessary.

NOTE

An oscilloscope and a detector mount equipped with a crystal provide a convenient method of monitoring the Klystron for optimum operation. Adjust the Klystron Power Supply REFLECTOR VOLTS and MOD. VOLT. controls so that a clean square wave of maximum amplitude appears on the oscilloscope.

12) Check the Klystron frequency by adjusting the X532A Frequency Meter until a dip occurs on the 415B meter. Adjust the Klystron as necessary. Read the frequency and then adjust the X532A off resonance.

13) Withdraw the probes of both Slide Screw Tuners. Tune the X485B Detector Mount for maximum indication on the 415B. Then tune Slide Screw Tuner No. 2 for maximum indication.

NOTE

For insertion-loss measurements, adjust the Tuners for unity SWR looking into the detector and generator. Refer to Paragraph 4-3 for procedure.

Procedure for Measuring Absolute Attenuation

- 1) Adjust the X382A and 415B GAIN control for full-scale 415B meter reading ("0" on the DB or EXPANDED DB scale).
- 2) Insert the attenuator under test between the two Slide Screw Tuners.
- 3) Adjust the 415B RANGE switch if necessary for an upscale reading.
- 4) Tune both Slide Screw Tuners for a maximum reading on the Attenuation Calibrator meter.

NOTE

For insertion-loss measurements, do not adjust the Tuners.

- 5) The attenuation of the attenuator under test is the 415B meter reading plus the change in the 415B RANGE switch setting.

Procedure for Measuring Relative Attenuation

For relative attenuation measurements, follow the same procedure as given in the previous example for measuring absolute attenuation.

3-3 ATTENUATION MEASUREMENTS WITH LINEAR DETECTION

GENERAL

Attenuation using a linear detection system is measured by comparing the rf attenuation of the attenuator under test with a standard IF attenuator. As shown in Figure 3-12, the signal source is heterodyned with a local oscillator in a mixer to provide a 30-megacycle output. The output is admitted to a precision standard attenuator, amplified, and displayed on an indicating device.

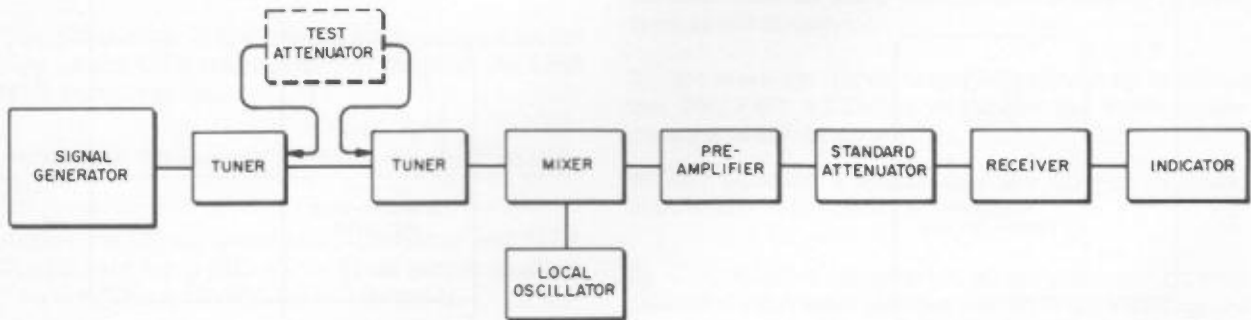

Figure 3-12. Linear Detection System for Attenuation Measurements

Attenuation is measured by adjusting the source power for a meter indication, inserting the attenuator under test, and then adjusting the standard attenuator for the same indication. The attenuation of the attenuator under test is the difference between the original standard-attenuator setting and the final setting.

The range of frequencies over which this attenuation-measuring system can be used depends chiefly upon the available mixers and sources. Signal sources must be so stable that two of them can hold a 30-megacycle beat frequency. Currently, mixers and sources are available that allow this system to be used from 40 megacycles to 18 kmc.

The amount of attenuation measurable in one step, with negligible error due to noise or nonlinearity, is about 50 db. Greater amounts of attenuation can be measured using more than one step. The total amount of attenuation that can be measured depends upon the total source power available. For example, with a source having +10-dbm output and a mixer that can be operated with negligible error to -80 dbm, 90 db of attenuation can be measured to the accuracy of the standard attenuator.

To achieve greatest accuracy and maximum range, the characteristics of the system must be determined before making any attenuation measurements. First, the level of the local oscillator must be set for the lowest mixer noise figure or for the operating point where a small change in local oscillator level has negligible effect upon the mixer output. Adjusting the local oscillator for lowest noise figure is usually impractical, because it can result in poor sensitivity. The optimum level can be determined by varying the local-oscillator input to the mixer with constant signal input, and noting the mixer output on the indicator. The oscillator must be set so that a change in local-oscillator level produces negligible change in mixer output.

The dynamic range of the system must also be determined. If the preamplifier is operated at minimum gain, the linearity of the mixer determines the upper limit. Mixers are limited by noise at low levels and by nonlinearity at high levels. The dynamic range can be determined by repeatedly measuring a fixed attenuator at various input power levels to the mixer. A decrease in the measured attenuation is noted both when the mixer starts to operate in the noise and when it is overdriven. A knowledge of the dynamic range permits optimum operation of the system.

ACCURACY

The accuracy of a measurement with a linear detection system depends upon several variables: nonlinearity of the mixer, signal level as set by noise, amplitude and frequency instability of the sources,

accuracy of the standard attenuator, and mismatch in the system.

At higher power inputs nonlinearity occurs in either the mixer or preamplifier. The effect of nonlinearity can be noted by measuring a fixed attenuator as previously discussed.

The ideal lower limit of signal level is set by thermal noise, while the actual limit is above the ideal because of conversion loss in the mixer and excess noise in both the mixer and the IF amplifier. The amount by which the actual limit exceeds the thermal noise limit is given by the noise figure (NF), which is defined by the following formula:

$$NF = L_C (N_R + N_{IF} - 1)$$

L_C is the conversion loss of the mixer (ratio of rf power input to IF power output), N_R is the noise ratio of the mixer (ratio of its noise output to that of a resistor at the same temperature), and N_{IF} is the noise figure of the IF amplifier. Noise figure is a power ratio and is usually expressed in db.

Typical values for a 1N21C crystal mixer are

$$L_C - 2.8 \text{ to } 3.5 \text{ (4.5 to 5.5 db)}$$

$$N_R - 1.15 \text{ to } 1.55$$

With an IF noise figure of 1.5 to 2.5 db, overall noise figures range from 6.5 to 9.0 db.

The Airborne Instruments Laboratories Model 130 Receiver has a bandwidth of 2 mc, so that the corresponding thermal noise level (KTB) is

$$4 \times 10^{-21} \times 2 \times 10^6 = 8 \times 10^{-15} \text{ watts} \\ = -111 \text{ dbm}$$

However, when no discrimination against image frequencies exists, the effective bandwidth-to-noise ratio is doubled, making the thermal-noise level -108 dbm. Thus the noise output of the overall system corresponds to a noise level of about -100 dbm at the mixer. While it is possible to operate down to noise level by making suitable correction for its effect, most accurate results are obtained by keeping the signal level well above noise. A level of about -80 dbm is attainable without appreciable error due to noise, while at -85 dbm the error is about 0.1 db.

Amplitude or frequency drift in the source is reflected as an error in the attenuator measurement. Most -hp- signal generators have short-term stability in the order of 0.01 to 0.1 db. If a 415B Standing Wave Indicator is used as the indicator, any drift of the

source modulation causes error, as the 415B operates as a sharply tuned voltmeter. This error can be eliminated by synchronizing the modulator with a frequency standard, electronic counter, or tuning fork.

The standard attenuator used with this system is a waveguide-beyond-cutoff type. The attenuation of this type depends upon only its physical dimensions. As these dimensions can be accurately machined and measured, the calibration of the attenuator is accurately known. This type of attenuator can be sent to NBS for calibration.

Mismatch is another source of error in attenuation measurements. It is thoroughly discussed in Paragraph 3-1.

As the output meter level is kept constant, any non-linearity in the output amplifier or output meter does not affect the accuracy of the measurement.

EXAMPLE: ATTENUATION MEASUREMENTS BETWEEN 40 MC AND 1230 MC

Range

Fixed Attenuation - 30 to 50 db

Variable Attenuation - 80 db

Accuracy

± 0.1 db or 1% of the measured attenuation, whichever is greater.

Preliminary Procedure

- 1) Connect the equipment as shown in Figure 3-13.

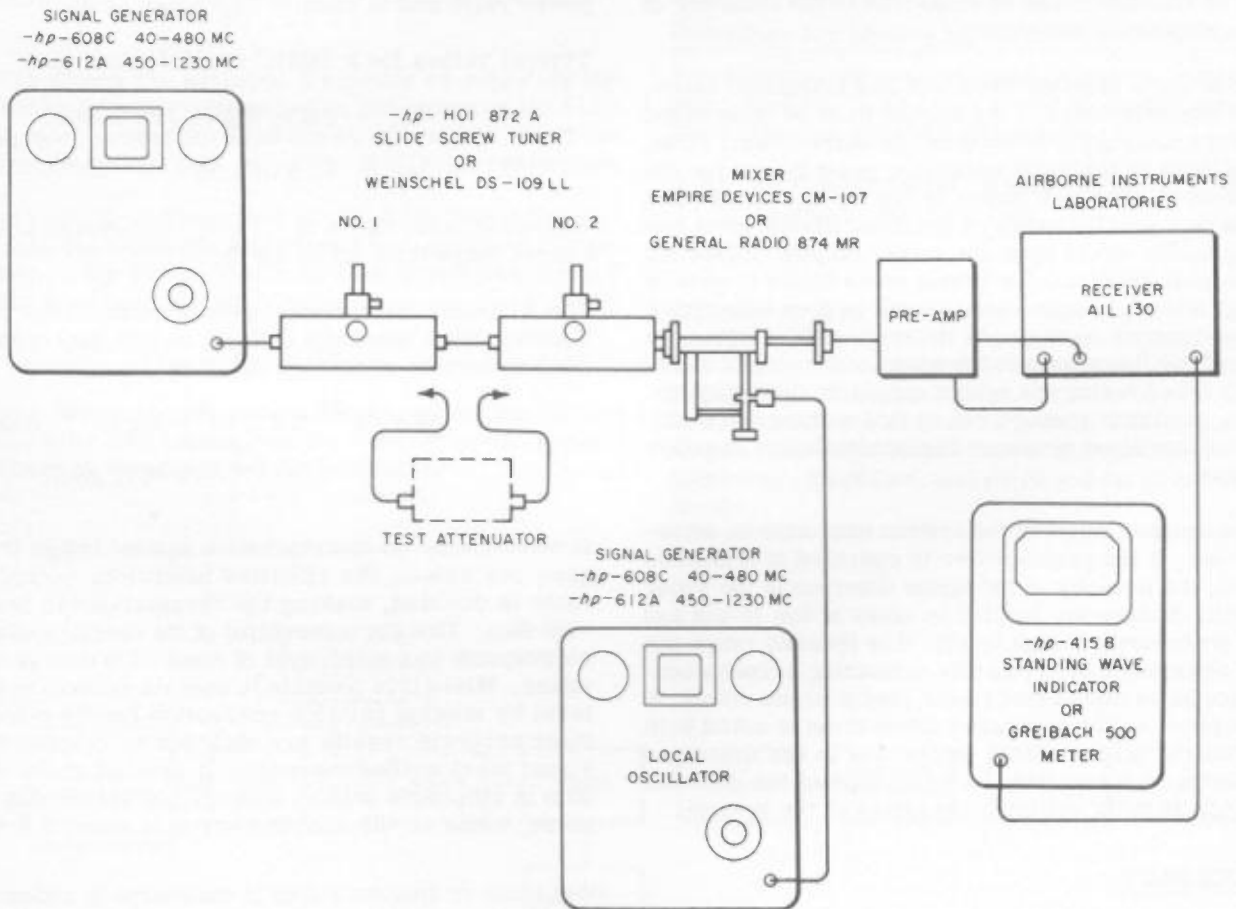

Figure 3-13. Attenuation Measurements with Linear Detector

2) Set the AIL 130 Receiver **SECOND DETECTOR RANGE** switch to X100. Set the standard attenuator to a reading of about 25 db.

3) If the Greibach 500 Meter is used, set it to **SHORT**.

4) Set the Signal Generator attenuators for maximum attenuation.

5) Connect the equipment to an ac power source, turn the equipment on and let it warm up for at least 30 minutes.

6) Set the **PREAMP GAIN** to minimum and **POST AMP GAIN** to maximum on the 130 Receiver.

7) Unscrew the coupling adjustment on the mixer in order not to overload the mixer crystal when adjusting the local oscillator.

8) Local Oscillator Adjustments:

Signal frequency 30 megacycles above or below test frequency. Modulation Selector switch to **CW**. If the Generator is a 608C, adjust the **AMP. TRIMMER** for a maximum deflection on the output meter. **OUTPUT LEVEL** control for an Output Level meter reading of +7.

Attenuator to maximum output.

9) Adjust the local-oscillator coupling screw at the mixer to obtain a reading of about 0.6 milliamps on the preamplifier meter (0.1 ma for the GR mixer). Readjust the **OUTPUT LEVEL** of the local oscillator.

10) Signal Generator Control Settings:
Frequency to the test frequency.
Modulation Selector switch to **CW**.
If the Signal Generator is a 608C, adjust the **AMP. TRIMMER** for a maximum deflection on the output meter.
OUTPUT LEVEL control for a meter reading of **SET LEVEL**.

NOTE

If the 415B is used, the Signal Generator must be modulated at 1000 cps with an external source.

11) Set the **SECOND DETECTOR RANGE** switch on the 130 Receiver to X1. Adjust the Signal Generator attenuator to obtain a deflection of about 50 microamperes on the Receiver meter.

12) Withdraw the probes of both Slide Screw Tuners. Tune Slide Screw Tuner No. 2 for a maximum indication on the meter.

NOTE

For insertion-loss measurements, adjust the Tuners for unity SWR looking into the load and mixer. See Paragraph 4-3 for procedure.

13) Adjust the local oscillator frequency to get a maximum reading, reducing the signal source level as necessary to keep the meter on scale. Readjust the coupling screw if necessary, for a reading of 0.6 ma on the preamplifier meter. The system is now ready for use.

Procedure for Measuring Absolute Attenuation (0 to 50 DB)

1) Set the signal level at the mixer to approximately -50 dbm.

2) Adjust the Standard Attenuator on the 130 Receiver for a deflection on the Receiver meter of about 30 microamperes.

3) Set the **SECOND DETECTOR RANGE** switch to **EXT**.

4) Set the external meter to the 50-microampere range. If the 415B is used, set the **METER SCALE** switch to **EXPAND** and the **RANGE** switch to 40.

5) Readjust Tuner No. 2 for a maximum reading on the external meter.

NOTE

Omit step 5 when making insertion-loss measurements.

6) Adjust the Signal Generator output or the 415B **GAIN** control (but not by more than ± 1 db) to obtain simultaneous, convenient reference settings on the Receiver Standard Attenuator and the external meter. Record the readings.

7) Insert the attenuator under test between the Tuners.

8) Adjust the Standard Attenuator on the Receiver for an upscale deflection on the external meter.

9) Adjust the Tuners for a maximum deflection on the external meter.

NOTE

Omit step 9 when making insertion-loss measurements.

10) Adjust the Standard Attenuator on the Receiver for the same deflection on the external meter as obtained in step 6.

11) Record the Standard-Attenuator setting. The attenuation of the attenuator under test is the difference between the initial Standard-Attenuator setting and the final setting.

Procedure for Measuring Relative Attenuation (0 to 50 DB)

1) After the preliminary procedure has been completed, insert the attenuator under test between the two Tuners and set it to the minimum attenuation desired.

2) Set the signal level at the mixer to approximately -50 dbm. The attenuator of the Signal Generator should read -50 dbm plus the total attenuation of the attenuator under test.

3) Adjust the Standard Attenuator on the 130 Receiver for a meter deflection of about 30 microamperes.

4) Set the SECOND DETECTOR RANGE switch to EXT.

5) Set the external meter to the 50-microampere range.

6) Adjust the Signal Generator output or 415B GAIN control (but not by more than ± 1 db) to obtain convenient, simultaneous reference settings on the Standard Attenuator and the external meter. Record the settings.

7) Set the attenuator under test to the first calibration point.

8) Adjust the Standard Attenuator for a deflection on the external meter. Tune the Slide Screw Tuners for a maximum deflection. Then adjust the Standard Attenuator for the reference deflection on the meter. Note the Standard-Attenuator setting.

9) The difference in attenuation between the reference setting and this setting of the attenuator under test is the difference in the Standard-Attenuator settings.

10) To calibrate the attenuator under test at more points, set the Standard Attenuator to the initial reading. (Step 6).

11) Set the attenuator under test to the next calibration point and repeat the attenuation measurement.

Procedure for Measuring Relative Attenuation Greater than 50 DB

1) Measure the first 50 db or less as above.

2) Increase the Standard-Attenuator attenuation by 30 db.

3) Increase the Signal Generator output for the initial external meter deflection.

4) Increase the attenuation of the attenuator under test to the next calibration point.

5) Decrease the Standard-Attenuator attenuation for a meter deflection and tune the Slide Screw Tuners for a maximum deflection. Then adjust the Standard Attenuator for the initial external meter deflection. Note the setting of the Standard Attenuator.

6) The relative attenuation of the attenuator under test (the difference between the reference setting and this setting) is the difference between the Standard-Attenuator reference setting and this setting plus the amount added by the Signal Generator (30 db).

3-4 REFERENCES

E. L. Ginzton, "Microwave Measurements," McGraw-Hill, New York, 1957.

C. G. Montgomery, "Technique of Microwave Measurements," McGraw-Hill, New York, 1948, vol. 11 of Radiation Laboratory Series.

B. O. Weinschel, Insertion Loss Test Sets Using Square Law Detectors, "Engineering Notes," No. 2 Weinschel Engineering Co., Inc.

B. O. Weinschel and G. U. Sorger, Precise Insertion Loss Measurements Using Imperfect Square Law Detectors and Accuracy Limitations Due to Noise, "Engineering Notes," No. 1, Weinschel Engineering Co., Inc.

Wind and Rapaport, "Handbook of Microwave Measurements" (2nd ed.), Polytechnic Institute of Brooklyn, New York, 1955.

SECTION IV IMPEDANCE

4-1 GENERAL DESCRIPTION

At frequencies from 50 to 500 megacycles the -hp-803A VHF Bridge is used to measure magnitude and phase of unknown impedances. The uncorrected accuracy of this measurement is 5% to 6% in magnitude, 3° to 4° in phase. With the correction charts provided with the VHF Bridge, these figures can be improved to 2% and 1.2°, respectively.

At higher frequencies the slotted-line or reflectometer setup is used for impedance measurements. With the slotted line, the standing-wave ratio (SWR) of a load is measured by determining the ratio of the maximum and minimum voltages on the line. Phase information is determined by observing the shift of a minimum when the load is replaced with a short. Then with the SWR and phase information the impedance of a load can be calculated or determined from the Smith chart.

The reflection coefficient is the ratio of voltage reflected from the load to that incident to the load. The reflectometer system easily provides the magnitude of the reflection coefficient. It is used where phase information is not important. Reflection coefficient is related to the SWR by the formula:

$$SWR = \frac{1 + |\rho|}{1 - |\rho|}$$

The reflectometer system usually provides greater accuracy and convenience for measuring small reflections than does the slotted line, as the incident and reflected voltages differ greatly in magnitude. Hence, the ratio is easily determined. Likewise, the slotted line provides greater accuracy at higher reflections, as the minimum and maximum voltages on the line are quite different. However, if proper precautions are taken, high accuracy can be obtained using either system.

For highest accuracy, both systems require special techniques. In the reflectometer system, tuners can be used to eliminate the effects of coupler directivity, source mismatch, and detector mismatch. With the slotted-line system, the null-shift technique is used to evaluate the residual reflection of slotted lines and to correct for this effect in impedance measurements.

4-2 IMPEDANCE MEASUREMENTS WITH THE 803A VHF BRIDGE (50 TO 500 MC)

GENERAL

The 803A VHF Bridge measures impedance over the 50 to 500 mc range. Measurements can be made over the much wider range from approximately 5 to 700 mc with reductions in accuracy and phase-angle range. The Bridge reads directly in impedance magnitude over a range from 2 to 2000 ohms and is also calibrated in impedance phase angle at 100 mc. At other frequencies the phase angle (θ) is given by the expression:

$$\theta = \frac{(\text{frequency mc})}{100 \text{ mc}} (\text{dial reading})$$

Phase angles between -90 and +90 degrees can be determined at any frequency above 50 mc. Because of its wide impedance range, the Bridge is capable of measuring almost any of the devices and components usually encountered in high-frequency work.

At frequencies above 100 mc, the distance from the sampling point to the end of the unknown terminal becomes important. This distance is approximately 3 cm or 1/100 wavelength at 100 mc. If the unknown load is not 50 ohms, it is transformed by 3 cm of line. This reduces the apparent impedance of capacitive unknowns and increases that of inductive unknowns. The effect can be avoided only by maintaining an insignificantly short distance between the sampling point and the load.

A Z- θ chart, as shown in Figure 4-1, may be used to determine the untransformed or actual load impedance quickly. The arcs centered on the horizontal line in the chart are constant-impedance contours; those centered on the vertical line are constant-angle. (The Z- θ chart is simply a transformed Smith chart.) The Bridge reading is located on the chart and the chart is then rotated clockwise an amount corresponding to the electrical length of 3 cm in a manner similar to the use of a Smith chart. The value obtained is the actual value of the unknown. An example is shown in Figure 4-1. Point A is the Bridge reading of 45 \angle 70° ohms. At a frequency of 500 mc, 3 cm is equal to 18 electrical degrees. The value at

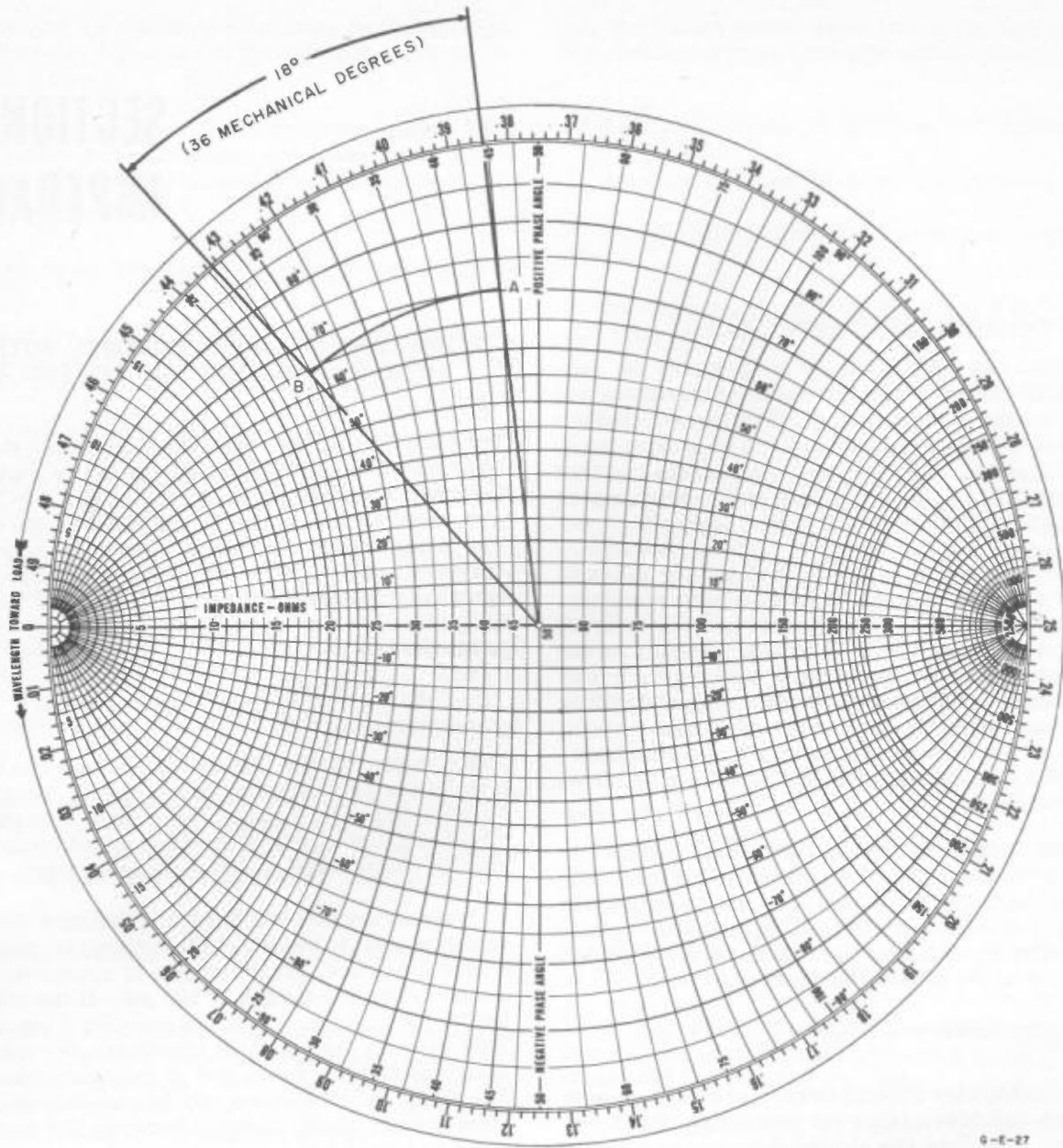

G-E-27

Figure 4-1. Z-Theta Chart Supplied with Bridge

A is thus transformed on an arc centered at the center of the chart to B, the corrected value.

This chart is useful for measuring loads that are located an appreciable distance away from their input connectors. To measure the load, first measure the length of line between the sampling point and the unknown by placing a short at the actual load. The Bridge does not indicate zero impedance, but gives a

larger reading because of the line transformation of the short. This reading, when located on the chart, is the fraction of a wavelength away from the short indicated by the calibration around the periphery of the chart. Therefore, when the short is removed and readings are made of the load impedance through the same cable, these readings are transformed by the length of line determined in the short-circuit measurement. A common situation in which this system

is useful occurs in measuring the impedance of antennas. A short placed at the antenna end of the cable, when read on the bridge and located on the chart, tells the significant fraction of a wavelength between the sampling point and the antenna. The actual antenna impedance can then be quickly found.

ACCURACY

Impedances can be measured by means of the Bridge with an accuracy within 5% for impedance magnitude and within 3 degrees for phase angle. However, these accuracy ratings are necessarily stated conservatively and do not take into account the important factor of Bridge technique.

The error in measurement of impedance with the 803A varies in cyclic fashion with frequency. Figure 4-2 shows these errors in magnified form for a typical Bridge. Curves of this type are supplied with each instrument to allow the operator to obtain maximum accuracy. Figure 4-2a shows the error in magnitude readings at three phase angles; 4-2b shows the error in phase-angle readings at three phase angles. With these curves the error of measurement can be estimated for nearly any reading of the Bridge. For example, in Figure 4-2a, the error at 100 mc at a phase angle of -90 degrees is $+2\%$, while at 0 degrees the error is 0% , and at $+90$ degrees about -1.3% .

Use of these correction curves significantly increases the accuracy of measurements. With them, measurements can be made within approximately 2% in magnitude and 1.2° in phase.

To calibrate the 803A Bridge, an open, a short, and an accurately calibrated 50-ohm load are required. A Weinschel 535 MN termination can be used for the 50-ohm load. The impedance of the open and short are measured at various frequencies and plotted versus frequency on a graph similar to that in Figure 4-2. The characteristic impedance Z_0 is then calculated from the formula $Z_0 = \sqrt{Z_{OC} Z_{SC}}$. The characteristic impedance is then plotted on the same graph. If the characteristic impedance is not 50 ohms, the dial of the 803A must be adjusted so that measurements of open and short circuits provide a characteristic impedance of 50 ohms.

Next, the errors in magnitude and phase for loads open, short, and of 50 ohms impedance are determined at various frequencies. The measured value of impedance varies in cyclic fashion about a straight line drawn through the point, and this variation indicates the error of the Bridge. When the error is plotted versus frequency, curves such as those found in Figure 4-2 result.

PROCEDURE

1) Connect the equipment as shown in Figure 4-3. For greatest sensitivity, use headphones with the 417A VHF Detector.

NOTE

A 415B Standing Wave Indicator can also be used. If a 415B is used, the signal source must be 1000-cps modulated.

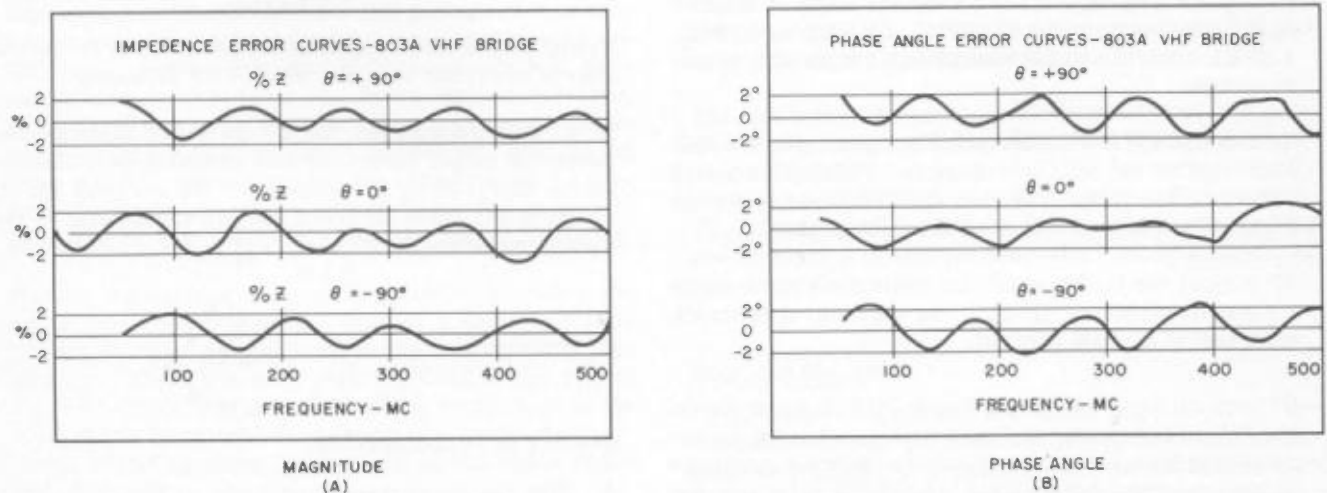

Figure 4-2. Typical Correction Curves Supplied with Bridge

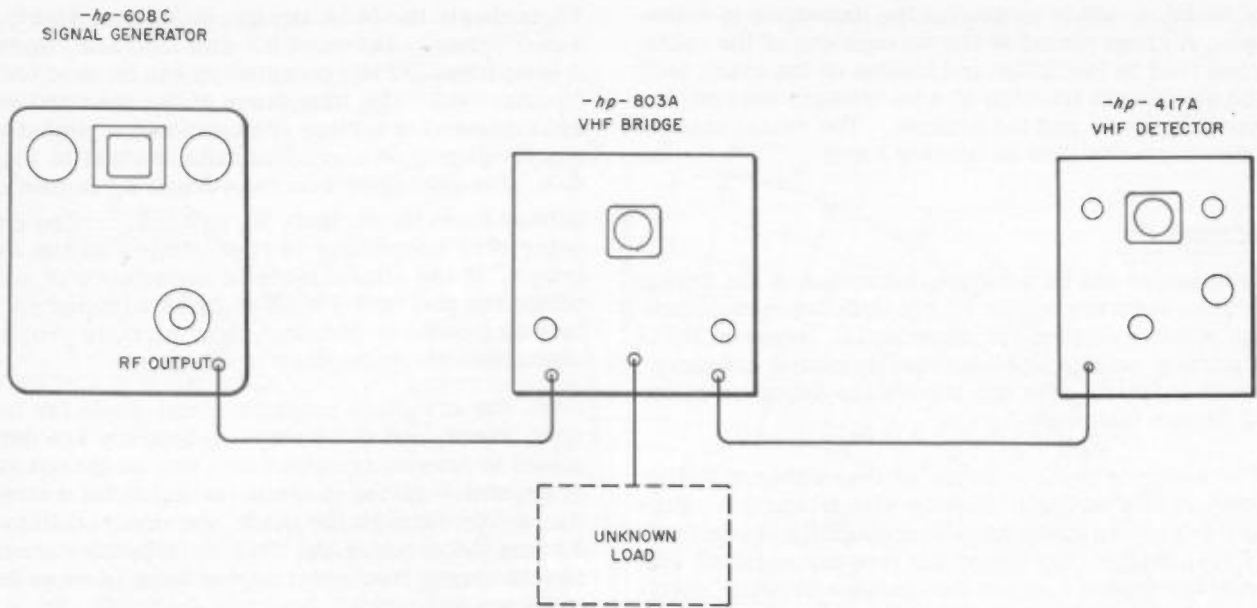

Figure 4-3. Impedance Measurement from 50 to 500 mc.

2) Set the 608C Signal Generator to the desired frequency. Set the output attenuator for minimum output. Set the MOD. SELECTOR switch to CW. Adjust the AMP. TRIMMER control for a maximum reading on the Output Level meter. Adjust the OUTPUT LEVEL control for a meter reading of +4 (labeled SET LEVEL).

3) Set the MOD. SELECTOR switch to 400 ~ or 1000 ~. Adjust the MOD. LEVEL control for a reading of about 90% on the modulation meter. Adjust the output attenuator for an output level of about 0 dbm, readjusting the OUTPUT LEVEL and MOD. LEVEL controls to maintain their respective meter readings.

4) Set the 417A VHF Detector frequency to a value near that of the 608C. Adjust the VOLUME control for maximum gain. Turn the QUENCH control to the right until a hiss is heard in the loudspeaker.

5) Adjust the tuning until the audio tone is heard at maximum volume. Reduce the volume, if desired, with the VOLUME control.

6) Adjust the MAGNITUDE and PHASE controls on the 803A VHF Bridge to find a null. Listen for an increase in hiss, which is noticeable before a decrease in tone volume. Adjust the 417A QUENCH control for best contrast between tone and hiss. Increase the signal level with the Signal Generator attenuator until the sharpest null is obtained.

NOTE

To avoid confusion, use the PHASE reading closest to zero. Only one null setting is possible at 50 mc, as the range is +90° to -90°. At 500 mc, however, the range is ten times as great, and up to ten null settings are possible.

7) Compute the phase angle from the formula

$$\theta = \frac{(\text{frequency, mc})}{100 \text{ mc}} (\text{dial reading})$$

Apply phase and magnitude corrections from the charts provided with the 803A VHF Detector.

8) At high frequencies, the 3-centimeter distance between the output connector and sampling point transforms the load by this amount. To correct for it, compute the distance from the sampling point to the load in wavelengths:

$$\begin{aligned} \Delta \lambda &= \frac{3 \text{ cm}}{\lambda} \\ &= \frac{3}{3 \times 10^4 / f} \\ &= f \times 10^{-4} \end{aligned}$$

where f is in megacycles.

9) Plot the measured impedance on the Z-θ chart. To find the impedance of the load, rotate the measured impedance at constant radius toward the load a distance of Δλ (as computed in step 8).

4-3 SWR MEASUREMENTS WITH THE SLOTTED LINE

GENERAL

When a transmission line is not terminated in its characteristic impedance, the mismatch causes some of the power to be reflected from the load. Similar reflections can occur from any discontinuity in the line. Where a condition of reflected power exists, the incident and reflected waves combine to form standing waves of current and voltage on the line. The relationship of the maximum to minimum voltages of the standing wave is expressed as the voltage standing wave ratio. The ratio varies from unity to infinity. At unity, no reflection occurs from the load; at infinity, complete reflection occurs.

To detect the standing-wave ratio, a slotted line is placed in the line. A probe extends into the slotted line and samples the rf voltage. The voltage is rectified by a detector, amplified, and indicated on a meter. The SWR can then be measured by sliding the probe along the line for a maximum meter indication and a minimum indication. The ratio gives the SWR. Indicators such as the 415B are calibrated directly in SWR.

The following paragraphs describe sources of error and good practices for avoiding them. * Signal sources can introduce at least three undesirable characteristics that affect slotted-line measurements: presence of rf harmonics, of fm, and of spurious signals.

RF Harmonics

RF harmonics commonly lead to serious errors in SWR measurements. Such harmonics are usually present to an excessive degree only in signal sources that have coaxial outputs. Coaxial pickups of a broadband type often pass harmonic frequencies with efficiencies greater than that with which they will pass the fundamental frequency. In waveguide systems, signal sources such as internal-cavity klystrons usually have a fixed coupling. In addition, they do not have pickups extending into the tuned cavity to disturb the cavity fields. Consequently, the harmonic problem is generally limited to coaxial systems.

Harmonics become especially troublesome when the reflection coefficient of a load at a harmonic frequency is much larger than at the fundamental frequency. When the harmonic content of the signal source is high, the large reflection coefficient of the load at the harmonic frequency can cause the harmonic standing-wave fields to be of the same order

of magnitude as the fields at the fundamental frequency. Thus, a load having a SWR of 2.0 at the fundamental frequency can have a SWR of 20 or more at the second harmonic frequency. If the load is driven from a signal source having 15% second harmonic, the maximums of the standing waves of the second harmonic are about one-fourth the amplitude of the maximums at the fundamental frequency. As most slotted-line probes must be experimentally tuned to the rf signal frequency, it is easy to improperly tune the probe to the second harmonic instead of to the fundamental. Thus, an SWR of 20 or more could be measured instead of 2.0. The tuning can be checked by noting the separation of minimums.

Other errors can result from harmonics because probes can couple significant energy into the detector at harmonic frequencies as well as at the fundamental. This is particularly true of untuned probes and is also prevalent in tuned probes of the distributed type. Under such conditions, the reading obtained is a combination of the fundamental and harmonic standing-wave patterns. Whenever significant harmonics are present or suspected, suitable low-pass filters must be inserted between the source and the equipment to reduce harmonics to a negligible value.

FM

A typical standing-wave pattern resulting from the presence of excessive frequency modulation in the signal source is shown in Figure 4-4. The minimum or trough, instead of falling to its natural value, appears to have a much larger value. With some types of fm, the trough can consist of two or more different minimums.

Other portions of the pattern can also exhibit irregularities when excessive fm is present. Under such circumstances, a casual measurement of SWR can easily lead to significant errors.

FM can occur in any modulated oscillator, and generally increases with the degree of amplitude modulation. In klystron signal sources, fm occurs usually because of poor filtering of the klystron power supply. The presence of fm can be detected by investigating the depth of a minimum when the load is a short, as shown in Figure 4-4.

Spurious Signals

When tuning a klystron, it is customary to adjust the repeller voltage for maximum power output at the desired frequency. If square-wave modulation is then added without regard to the operating voltages, the repeller-voltage excursions will be incorrect. On square-wave peaks the repeller voltage does not stabilize at the point of maximum power output, but

*W.B. Wholey, Good Practices in Slotted Line Measurements, "-hp- Journal," vol. 3, Nos. 1 and 2.

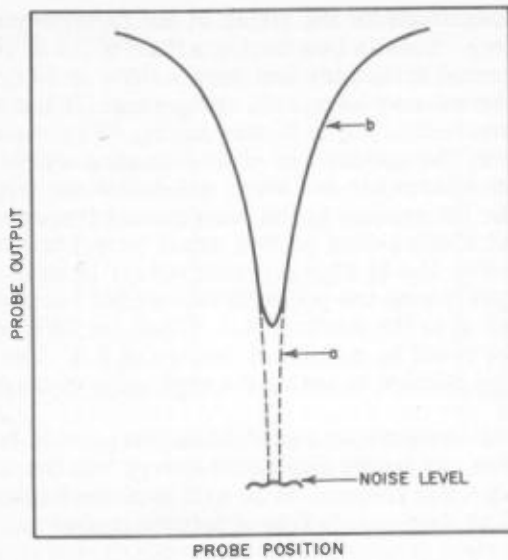

Figure 4-4. Plot of High-SWR Field Pattern
(a) With No FM (b) With Moderate FM

swings between a point which may or may not lie in the desired mode and a point which can lie in an undesired mode. When this occurs, two frequencies are present in the output of the klystron, with results similar to frequency modulation of the signal source.

It is also possible to obtain a two-frequency output when the square-wave voltage passes through an un-suppressed mode during its leading or trailing edge. Such a condition is more likely to occur at the trailing edge of the square wave, because of the relatively slow decay of charged capacities in the circuit.

Precautions must be taken whenever square-wave modulation is applied to the repeller through a capacitor, especially when using a general-purpose klystron supply. When square-wave modulating, adjust the repeller voltage and the modulating voltage so that modulating peaks lie in the desired repeller mode, and the modulating troughs do not lie in any mode that permits the tube to oscillate. The rising and falling portions of the modulating voltage must not pass through undesired modes. An oscilloscope connected to the detector provides a convenient method of monitoring a klystron for optimum square-wave operation.

Probe Penetration

The penetration of the sampling probe into the line must be kept at a minimum. Excessive penetration of the sampling probe is one of the major sources of error.

As the sampling probe extracts power from the line in order to supply the detector and indicating device, the probe can have an effect on the fields within the line. This effect usually becomes greater as probe penetration is increased. Probe penetration essentially acts as an admittance shunting the line. Generally, this admittance is kept small by coupling as loosely as possible (small penetration). Also it is minimized by using a high-sensitivity detector in conjunction with a signal source having a power output in the order of one milliwatt or more.

If the coupling between the probe and line is significant, the shunt admittance introduced by the probe causes the measured SWR to be lower than the true SWR, and shifts both the maximums and minimums from their natural positions.

Greater probe penetration can be tolerated when examining a standing wave of high ratio, because the minimum corresponds to a low-impedance point in the line. However, the SWR must be high before tolerating substantial probe penetration. The probe penetration can be checked by withdrawing the probe slightly and repeating the SWR measurement. If the difference between the two SWR's is greater than 1%, probe penetration is excessive.

Location of Minimums

Generally, the voltage minimum must be located, rather than the voltage maximum, as probe loading has less effect on the minimum. The location of the minimum on low standing-wave ratios by a single measurement is usually inaccurate, as the minimum can be quite broad. A more accurate method of locating the minimum is to average the probe-carriage readings on each side of the minimum that provide equal output-indicator readings.

Detector Characteristics

Both crystals and platinum-wire bolometers exhibit a departure from the ideal square-law response for which standing-wave indicators are calibrated. For crystals this departure occurs when the rf power level exceeds a few microwatts. With barretters a somewhat higher power level can be tolerated. However, the sensitivity of crystals is considerably better than that of bolometers, so crystals are widely used as detectors for SWR measurements.

The characteristic of either a crystal or a bolometer is easily checked with slotted-line equipment by increasing the power level in the line in known steps and noting the detector response on the standing-wave indicator. Any new crystal must be checked, as significant variations occur between crystals.

Standing-wave measurements can be made that do not depend upon the square-law response of the detector. Such a measurement uses a signal source with a calibrated attenuator. For greatest accuracy, the attenuator must have an attenuation which follows a natural law determined by physical dimensions.

To measure SWR with an attenuator, first adjust the signal generator for maximum output. Then adjust the probe coupling at a minimum in the standing-wave pattern to give a suitable reading on the indicator. Move the sampling probe to a voltage maximum and adjust the attenuator for the same reading as before on the standing-wave indicator. The standing-wave ratio (in db) is then equal to the difference in the readings of the two attenuator settings. This method eliminates errors caused by nonlinearity of the detector element, as the detector element is operated at the same level for both readings.

Slope

Slope occurs in a slotted line because of energy leakage through the slot. It can be detected by moving the probe carriage along the slotted line and noting the magnitude of the minimums. If they vary in magnitude from one end to the other, leakage occurs through the slot. If noticeable slope occurs, the slotted section of lines such as the -hp- 809B and 810B can be adjusted with the holding screws to provide minimums of constant amplitude over the entire section.

Connectors

The accuracy of SWR measurements in coaxial systems is limited because of the type-N connectors employed. The SWR of type-N connectors ranges from 1.04 to 1.3 depending upon the model of connector, the frequency, and the condition of the connector. Connectors do not limit the accuracy in waveguide systems, as waveguides can be joined with a practically negligible SWR. However, the accuracy can be increased in coaxial systems by employing special techniques such as the null-shift technique.

High SWR

The measurement of SWR with conventional methods is generally satisfactory when measuring SWR's in the range of 1 to 12, but larger SWR's require special techniques.

When the SWR is large, the probe coupling must be high for a reading at the minimum. Large coupling can result in a deformation of the pattern when a maximum is measured. Hence, error can result. In addition to the error caused by probe coupling, the detector can be driven into a non-square-law region.

The double minimum method provides accurate measurements of high SWR's. The validity of the double minimum method depends upon an approximation of a parabola for the standing-wave pattern in the vicinity of the minimum. With this method it is necessary only to establish the electrical distance between power points that are twice the amplitude of the minimum (3 db). The SWR can then be computed from the expression:

$$SWR = \frac{\lambda_g}{\pi(d_1 - d_2)}$$

where λ_g is the guide wavelength in centimeters, and d_1 and d_2 are the locations of the twice minimum points in centimeters.

Low SWR

The sampling probe in the slotted section produces reflections. Reflections from the probe travel back toward the generator. If the generator is mismatched, these reflections are reflected toward the load. When the probe is moved under these conditions, the phase of the reflections changes, causing error. As reflection from the generator is a second-order effect, it is important only when measuring low SWR's in the order of 2 or less. A good match reduces these effects. Probe reflections, of course, must be kept as low as possible by minimizing probe penetration.

Accurate measurement of the position of the minimum when the SWR is low is difficult because the minimum is broad. When the precise location of the minimum is desired, establish points on each side of the minimum that have the same value. Averaging the locations of these points provides greater accuracy than does direct measurement. The locations of equal-amplitude points are more easily established because of the higher slope of the pattern. If the SWR is extremely low, the null-shift technique must be used to correct for the residual of the slotted line.

The following examples show SWR measurements in coaxial and waveguide systems. They are useful for checking the SWR of loads, pads, adapters and signal generators.

SWR MEASUREMENTS BETWEEN 800 AND 4000 MC

Accuracy

For SWR's of less than 10 - approximately $\pm 4\%$ of the indicated reading.

Preliminary Procedure

1) Connect the equipment as shown in Figure 4-5.

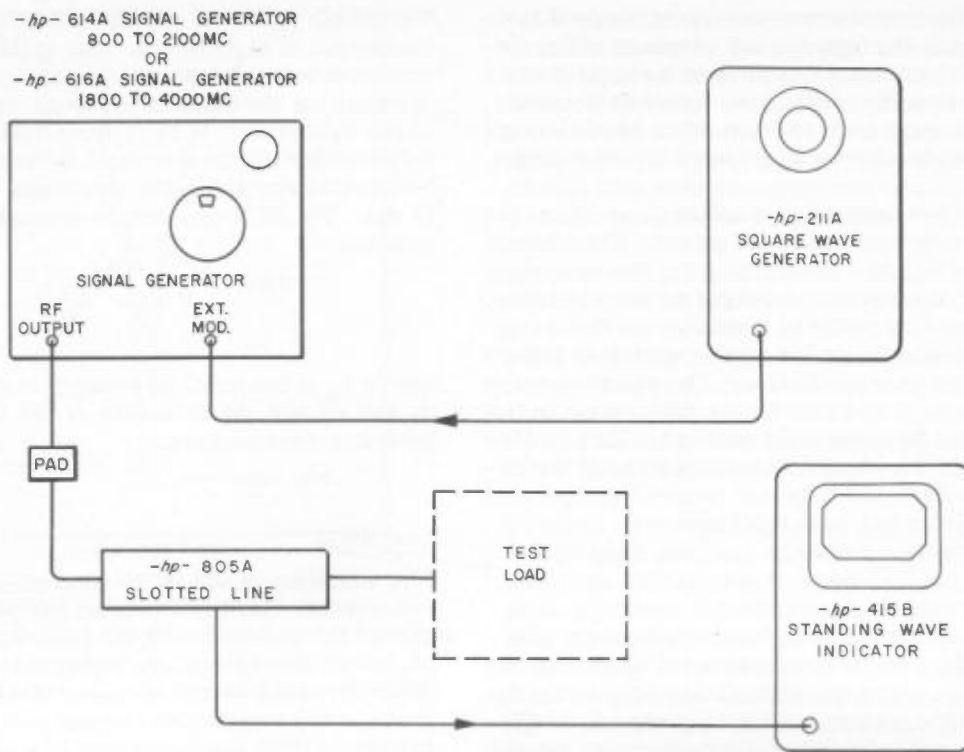

Figure 4-5. SWR Measurements between 800 and 4000 mc

- 2) 211A Square Wave Generator Control Settings:
 RANGE switch to X100.
 FREQUENCY control to 10.
 OUTPUT AMPLITUDE control fully clockwise.
- 3) Signal Generator Control Settings:
 SIGNAL FREQUENCY control to the test frequency.
 FM-CW-OFF switch to OFF.
- 4) 415B Standing Wave Indicator Control Settings:
 RANGE switch to 30.
 INPUT SELECTOR switch to CRYSTAL 200KΩ.
 GAIN control maximum clockwise.
 METER SCALE switch to NORMAL.
- 5) Connect the equipment to 115V ac power. Turn on all equipment and allow it to warm up for 15 minutes.

Procedure

- 1) Signal Generator Control Settings:
 ZERO SET control for a ZERO SET reading on the meter.

FM-CW-OFF switch to CW.
 POWER SET control for a POWER SET reading on the meter.
 OUTPUT ATTEN control to -10 dbm.
 FM-CW-OFF switch to EXT NEG.

- 2) Set the RANGE switch on the 415B to obtain an indication on the meter.
- 3) Adjust the 211A FREQUENCY control for a maximum deflection on the 415B, switching the 415B RANGE switch as necessary. (A "deflection" occurs when the pointer moves to the right.)
- 4) Adjust the tuning knob on the 805A Slotted Line for a maximum deflection on the 415B. If necessary, switch the 415B RANGE switch to keep the pointer on scale.
- 5) Connect the load under test to the 805A. Move the probe carriage along the slotted line for a maximum deflection on the 415B, switching the RANGE switch if necessary.
- 6) With the 415B RANGE switch to 30, METER SCALE switch to NORMAL, and GAIN control to near-

ly maximum, adjust the probe penetration of the 805A for a full-scale meter deflection (1 on the SWR scale). The crystal in the 805A has the proper rf power input when the 415B meter indicates full scale with the switches set as stated above. (After this adjustment has been completed, the 415B switches and 805A probe carriage can be moved to any position during the course of the measurement without overloading the crystal.)

7) Move the probe carriage along the 805A for a minimum deflection on the 415B. Read the SWR. If the SWR is greater than 3, switch the RANGE switch and read on the 3-to-10 scale.

8) If the SWR is less than 1.3 set the METER SCALE switch to EXPAND, switching the RANGE switch to obtain an upscale deflection.

9) Move the probe carriage along the 805A to obtain a maximum deflection on the 415B, switching the RANGE switch as necessary. Adjust the 415B GAIN control and Signal Generator attenuator to obtain a full-scale deflection on the EXPANDED SWR scale.

10) Move the probe carriage along the 805A to obtain a minimum deflection on the 415B. Read the SWR.

11) Withdraw the probe on the 805A by a slight amount and repeat the SWR measurement. Repeat until a difference of less than 1% is obtained between consecutive readings.

12) If the SWR is over 10, the double-minimum method is suggested for greater accuracy. Set the carriage to a voltage minimum. Adjust the Signal Generator attenuator if necessary to obtain a convenient reading on the 415B.

13) Slide the carriage to the positions on each side of the null which result in readings 3 db higher on the 415B. Read and record the carriage positions.

14) Compute the SWR from the equation:

$$\text{SWR} = \frac{\lambda_g}{\pi D}$$

where

D is the difference between the carriage positions in centimeters (step 13).

λ_g is the wavelength in centimeters. The wavelength is equal to twice the distance between two adjacent minimums.

Examples (refer to Figure 4-6):

1) If, at the minimum, the 415B reads 1.3 on the uppermost scale (solid pointer line in Figure 4-6), the SWR is 1.3.

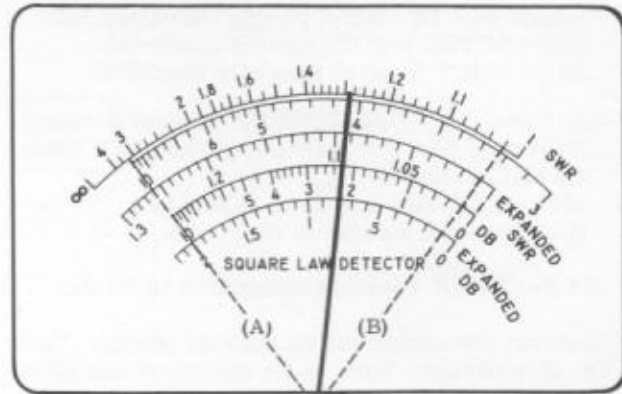

Figure 4-6. Detail of Meter Face

2) If the SWR is greater than 3 on the uppermost scale (dashed pointer line A in Figure 4-6), set the RANGE switch to the next range and read the indication on the second SWR (3 to 10) scale. In this case the reading is 3.25 (dashed pointer line B).

3) If the RANGE switch must be changed by two ranges the scale shifts twice, back to the top scale again; however, the full-scale reading is now 10 instead of 1.

4) If the SWR is 1.3 or less it can be read on the EXPANDED SWR scale. After the METER SCALE switch is set to EXPAND the meter pointer will pin downscale and must be reset to full scale by increasing the meter sensitivity using the GAIN control and/or the RANGE switch.

5) The standing-wave ratio is also indicated in decibels on the DB and EXPANDED DB scales. SWR's of less than 2.2 db can be read on the EXPANDED DB scale.

SWR MEASUREMENTS BETWEEN 8.2 AND 12.4 KMC

Accuracy

For SWR's less than 10 - approximately $\pm 1\%$ of the indicated reading in waveguide, $\pm 6\%$ to 10% in coax.

Preliminary Procedure

1) Set up the equipment as shown in Figure 4-7. An -hp- 620A or 626A Signal Generator can be used for the signal source.

2) 715A Klystron Power Supply Control Settings:
REFLECTOR RANGE switch to 600-900.
MOD. SELECTOR switch to OFF.

BEAM VOLTS control to approximately 380.
REFLECTOR VOLTS control clockwise.
MOD. VOLT. control partially clockwise.

- 3) 415B Standing Wave Indicator Control Settings:
INPUT SELECTOR switch to CRYSTAL 200Ω.
RANGE switch to 30.
METER SCALE switch to NORMAL.
GAIN control maximum clockwise.
- 4) Set the X382A Variable Attenuator to 20 db.
- 5) Connect the equipment to 115V ac power. Turn on the klystron fan. Turn on all equipment and allow it to warm up for 10 minutes.
- 6) Set the X-13 Klystron micrometer to the test frequency.
- 7) Set the 715A MOD. SELECTOR control to 1000~. Decrease the REFLECTOR VOLTS control setting until the Klystron starts oscillating, as indicated by a jump in the cathode current.
- 8) If necessary, switch the RANGE switch on the 415B to obtain an upscale deflection.
- 9) Adjust the 715A MOD. FREQ. control for a maximum deflection on the 415B, switching the RANGE switch as necessary.

10) Adjust the 715A REFLECTOR VOLTS and MOD. VOLT. controls for a maximum deflection on the 415B, switching the RANGE switch as necessary.

11) Check the Klystron frequency by adjusting the X532A Frequency Meter until a dip occurs on the 415B. Read the frequency and then turn the Frequency Meter knob at least one-fourth turn from the resonance setting.

Procedure

- 1) Connect the load under test to the end of the Slotted Section. Align the waveguide sections carefully to prevent erroneous readings.
- 2) Move the probe carriage along the Slotted Section to obtain a peak deflection on the 415B.
- 3) With the 415B GAIN control nearly maximum and the RANGE switch on 30, vary the rf power level with the X382A to obtain a reading of 1 on the SWR scale. The crystal in the Slotted Section probe now has the proper rf power input. (After this adjustment has been completed, the 415B switches and probe carriage can be moved to any position during the course of the measurement without overloading the crystal.)
- 4) Move the probe carriage along the Slotted Section to obtain a minimum deflection on the 415B. Read

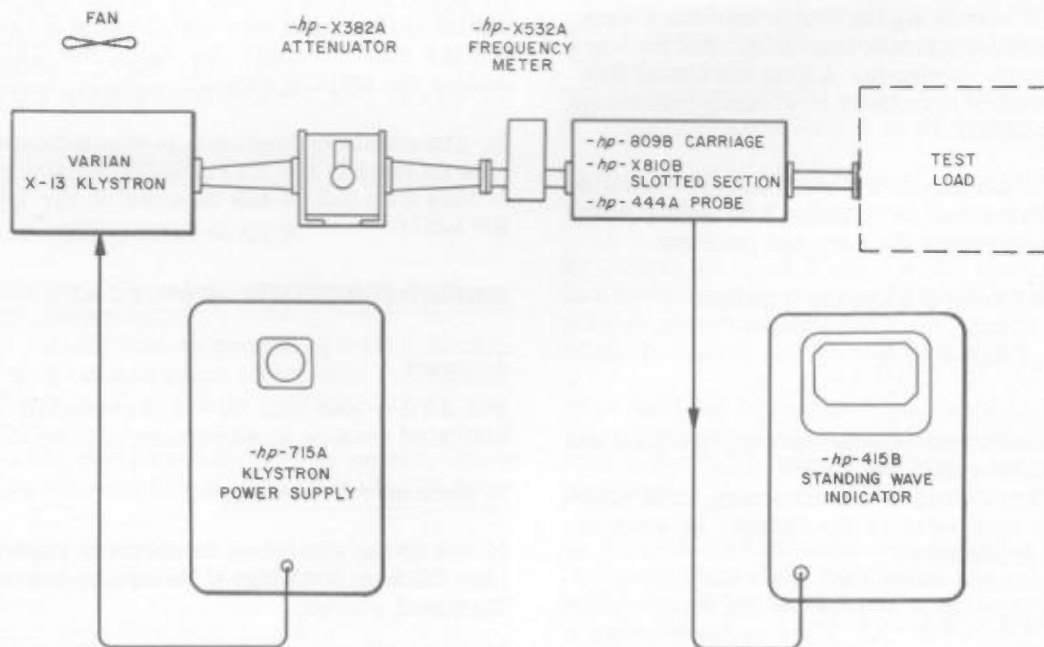

Figure 4-7. SWR Measurements in X-Band (8.2 to 12.4 kmc)

the SWR. If the SWR is greater than 3, switch the RANGE switch to the next position and read on the 3 to 10 SWR scale.

5) If the SWR obtained in step 4 is less than 1.3, then switch the METER SCALE control to EXPAND.

6) Move the probe carriage to obtain a maximum deflection on the 415B, switching the RANGE switch as required. Adjust the 415B GAIN control and the X382A to obtain a full-scale deflection on the EXPANDED SWR scale.

7) Move the probe carriage along the Slotted Section to obtain a minimum deflection on the 415B. Read the SWR.

8) Withdraw the probe slightly from the Slotted Section by loosening the LOCK and pulling the probe upward. Relock and repeat the SWR measurement. Continue to withdraw the probe, and repeat until succeeding measurements are within 1% of each other. If necessary, decrease the attenuation of the X382A to provide more signal to the 415B.

9) For SWR's over 10 use the double-minimum method.

4-4 SWR MEASUREMENT OF TRANSMISSION SYSTEMS BY THE SLIDING-LOAD TECHNIQUE

GENERAL

Frequently, it is desirable to determine how much of a SWR can be attributed to the load and how much to the transmission system. For example, in standards work, it is necessary to determine the residual SWR of slotted lines and adapters to insure that they meet specifications.

The "residual" SWR of a transmission system in measurement work arises from the presence of one or more low-loss discontinuities. In SWR measurements, only the discontinuities between the sampling probe and the load end of the transmission system and discontinuities caused by the probe are considered, as long as the power source is well matched to the system. The discontinuities that cause the "residual" of the system are considered as a single lumped discontinuity. This assumption is valid at a single frequency.

One method of determining the "residual" of the system involves measuring the SWR of the system when terminated by a sliding load with low SWR. Ideally, the slotted line or adapter should be terminated with a load having no reflection. Then the SWR of the transmission system could be measured directly.

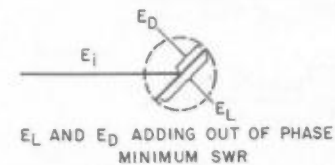
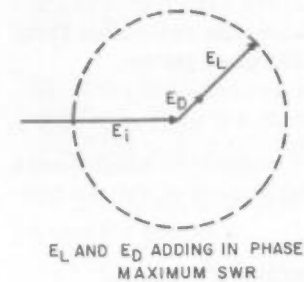
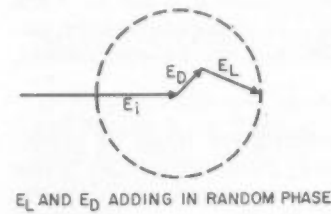
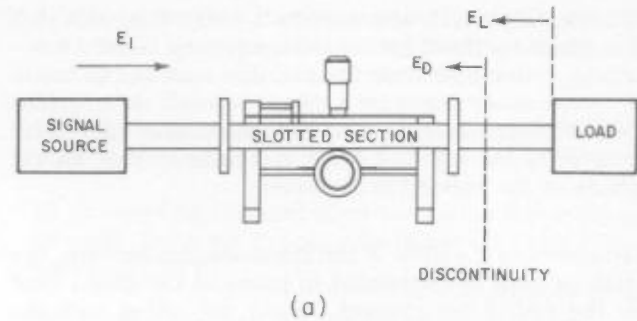

(b)

Figure 4-8. (a) Typical Setup Using Sliding Load
(b) Relation of Incident and Reflected Voltages when making Measurements with Sliding Load.

However, as all loads have some reflection, one is chosen that has approximately the same amount as that of the residual to be measured. As the load can be moved, reflections from the load can be distinguished from those caused by a discontinuity in the transmission system. Any discontinuity in the connector of the load is lumped in with the residual of the transmission system. Only the residual SWR of the load can be isolated from the rest of the system.

Where a discontinuity causes a reflection of which the phase is fixed (provided frequency is held constant), reflections from the movable load can be made to occur in any phase by moving the load. In a typical SWR measurement, moving the load causes the meter pointer of the standing-wave indicator to vary as the phase of the reflection is varied.

To measure the SWR of the transmission system, the sliding load is connected in place of the usual load at the end of the system. Then, adjusting both the position of the probe carriage on the slotted section and the position of the sliding load, the highest obtainable SWR is sought and measured. The maximum SWR occurs when the reflection of the load and discontinuity add in phase. This measurement requires some care, as the settings are interdependent.

Now, a second SWR measurement must be made. To make this measurement, first return the probe to the position of the original maximum or peak. Then adjust the sliding load and measure the SWR to obtain a minimum SWR on the standing-wave indicator. This SWR occurs when the reflection from the load and discontinuity add out of phase.

The maximum and minimum reflection coefficients can be calculated and the reflection of the discontinuity identified.

$$\rho_{\max} = \frac{\text{SWR}_{\max} - 1}{\text{SWR}_{\max} + 1}$$

$$\rho_{\min} = \frac{\text{SWR}_{\min} - 1}{\text{SWR}_{\min} + 1}$$

As the reflection coefficients of the discontinuity and load add to give ρ_{\max} and subtract to give ρ_{\min} , the following relationships can be written:

$$\rho_{\max} = \rho_L + \rho_D$$

$$\rho_{\min} = \rho_L - \rho_D \text{ or } \rho_D - \rho_L$$

where ρ_L and ρ_D are the reflection coefficients of the load and discontinuity respectively.

Solving for ρ_L and ρ_D

$$\rho_L \text{ or } \rho_D = \frac{\rho_{\max} + \rho_{\min}}{2}$$

$$\rho_L \text{ or } \rho_D = \frac{\rho_{\max} - \rho_{\min}}{2}$$

To uniquely determine ρ_L or ρ_D if neither is known, it is necessary to perform a second SWR measurement using a different load or different device containing the discontinuity. Or, the SWR of the load can be found by moving the load back and forth with the probe carriage fixed in the slotted line, and reading the SWR. Then the reflection coefficient of the discontinuity can be identified as described below.

PROCEDURE

For example, when measuring the SWR of a coax-to-waveguide adapter, the coax output is terminated with a sliding load. The reflection of the sliding load, adapter, and slotted line all add according to their phase relationship. For purposes of this example, assume that the residual reflection of the waveguide slotted section is negligible. (It usually is negligible when compared to the reflection of the adapter.) Figure 4-9 illustrates the equipment setup and shows the residual reflections of the load and adapter.

To find the SWR of the adapter, adjust the moving load until the measured SWR is a maximum, using SWR-measuring techniques described in Paragraph 4-3. This condition occurs when ρ_L and ρ_A add in phase. Then calculate the ρ_{\max} from the formula relating SWR and ρ (reflection coefficient):

$$\rho_{\max} = \frac{\text{SWR}_{\max} - 1}{\text{SWR}_{\max} + 1}$$

Adjust the moving load until the measured SWR is a minimum. This condition occurs when ρ_L and ρ_A add out of phase. Then calculate ρ_{\min} :

$$\rho_{\min} = \frac{\text{SWR}_{\min} - 1}{\text{SWR}_{\min} + 1}$$

Then, because ρ_A and ρ_L add in phase to give ρ_{\max} , and add out of phase to give ρ_{\min} , the following relations can be written:

$$\rho = \frac{\rho_{\max} + \rho_{\min}}{2}$$

$$\rho = \frac{\rho_{\max} - \rho_{\min}}{2}$$

However, either value of ρ can be ρ_A , and the other is then ρ_L . To determine ρ_A , it is necessary to perform the same measurement on a second adapter. As the same load is used for both measurements, one of the reflection coefficients found when measuring the second adapter will be identical to one of those found when measuring the original adapter. Hence,

the reflection coefficient common to both is the reflection coefficient of the load, and the other value is the reflection coefficient of the adapter.

The SWR of the adapter can then be found from the formula:

$$SWR_A = \frac{1 + \rho_A}{1 - \rho_A}$$

The same technique is used to measure the residual SWR of slotted lines.

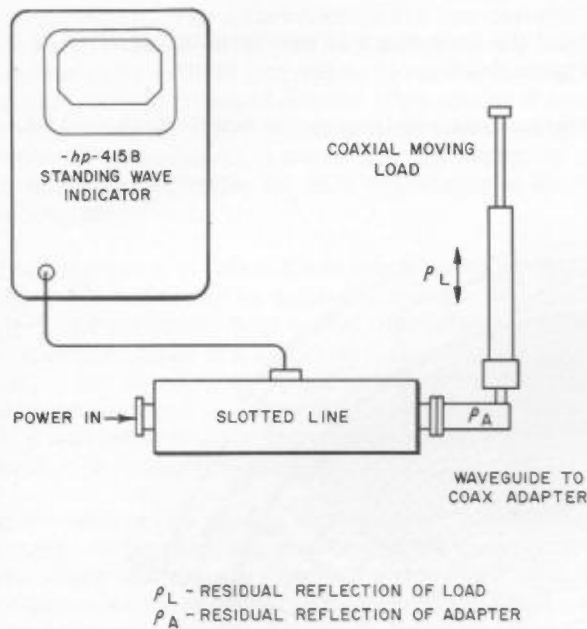

Figure 4-9. SWR Measurements of Adapters and Slotted Lines

4-5 IMPEDANCE MEASUREMENT

GENERAL

The impedance of a load can be measured with a slotted line. The SWR of the load is measured as described in Paragraph 4-3, and the shift of a minimum is noted when the load is replaced with a short. Then the normalized load impedance can be computed or determined from the Smith chart. The Smith chart is a polar plot of reflection coefficient versus impedance and permits rapid determination of load characteristics.

Some helpful rules for slotted-line measurements:

1) The shift in the minimum when the load is shorted is never more than one-quarter wavelength.

2) If shorting the load causes the minimum to move toward the load, the load has a capacitive component.

3) If shorting the load causes the minimum to shift toward the generator, the load has an inductive component.

4) If shorting the load does not cause the minimum to shift, the load is completely resistive and has a value Z_0/SWR .

5) If shorting the load causes the minimum to shift exactly one-quarter wavelength, the load is completely resistive and has a value of $Z_0 \times SWR$.

IMPEDANCE MEASUREMENT PROCEDURE

1) Connect the load under test to the slotted section and measure the SWR as described in Paragraph 4-3. Note the position of a minimum in the standing-wave pattern.

2) Replace the load with a short at the load end of the line.

3) Determine the new minimum position with the line shorted. Note the direction of probe movement (toward the load or toward the generator).

4) The normalized load impedance can be computed from the formula:

$$Z_L = \frac{1 - j(SWR) \tan X}{SWR - j \tan X}$$

where

$$X = \frac{180^\circ (\pm \Delta d)}{\lambda/2}$$

$\pm \Delta d$ = Shift in centimeters of the minimum point when the short is applied. Δd is positive when the minimum shifts toward the load. Δd is negative when the minimum shifts toward the generator.

$\frac{\lambda}{2}$ = One-half the line or guide wavelength. It is the distance in centimeters as measured between two adjacent minimums.

The actual impedance of the load is found by multiplying the normalized impedance times the characteristic impedance of the line, or the normalized impedance can be found by using the Smith chart.

5) Calculate the shift of the minimum in wavelengths.

$$\Delta \lambda = \frac{\Delta d}{\lambda} \quad (\Delta d - \text{shift of minimum in cm.})$$

6) Starting at the center of the Smith chart, draw a circle with the SWR as the radius.

7) Starting at the short on the Smith chart (zero impedance) proceed in the direction of probe movement (toward load or toward generator) a distance of $\Delta\lambda$. Draw a radius.

8) The uncorrected impedance of the load is at the intersection of the radius and the SWR circle.

9) An example will clarify this procedure:

The SWR is measured as 3.3.

The distance between two adjacent minimums is 15 cm; therefore the wavelength of the line is 30 cm. (λ_L).

A convenient minimum is located at 22 cm.

The line is shorted.

The minimum point shifts to 19 cm, (toward generator).

$$\Delta d = 22 - 19 = 3 \text{ cm.}$$

$$\Delta\lambda = \frac{\Delta d}{\lambda_L} = \frac{3}{30} = 0.1 \text{ wavelength}$$

Construct SWR circle on the Smith chart.

Construct a radius to the wavelength-shift point.

Read the impedance at the intersection at point A on Figure 4-10.

The normalized impedance equals $0.44 + j0.64$.

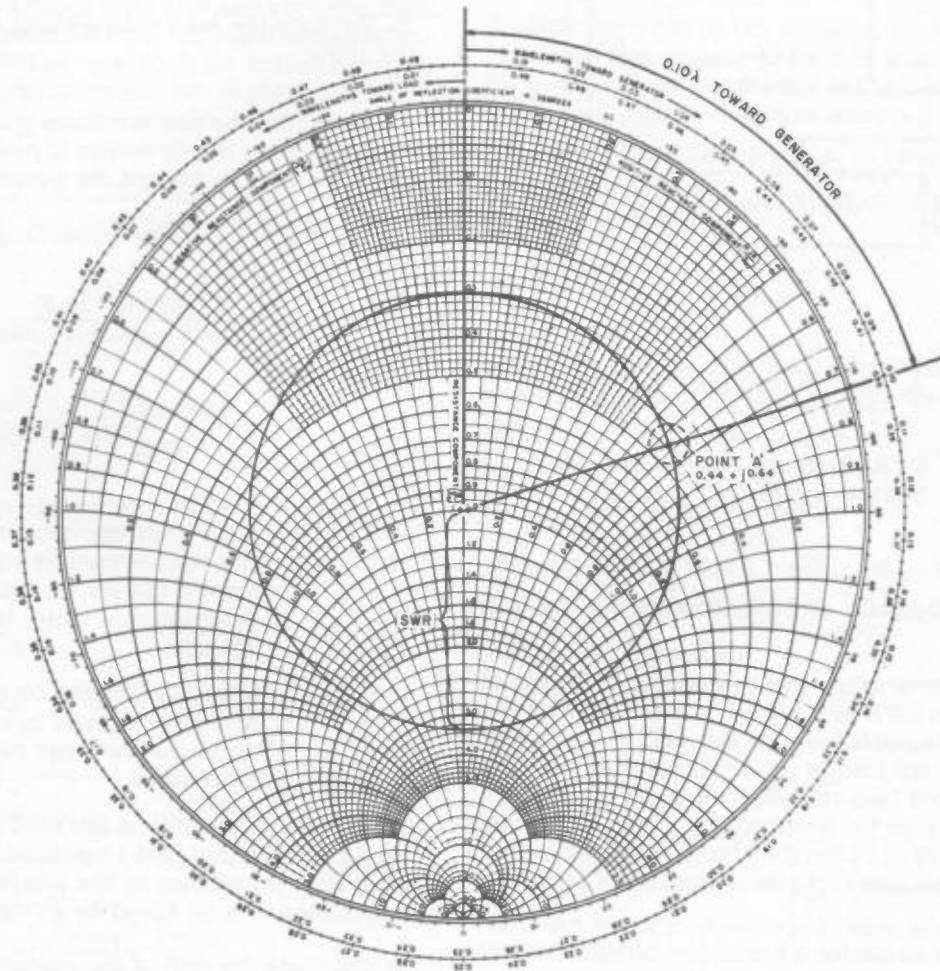

Figure 4-10. Smith Chart Showing Impedance of Load

4-6 NULL-SHIFT TECHNIQUE FOR RESIDUAL-REFLECTION AND IMPEDANCE MEASUREMENT CORRECTIONS

GENERAL

The null-shift technique is used for determining the residual SWR of a slotted line. A typical null-shift set, such as the -hp- K04 999B, consists of coaxial center conductors of various lengths and one outer conductor.

Information concerning the minor discontinuity can be obtained by determining the manner in which the phase of the reflection from an open circuit (or a short) is affected by the reflection from the minor discontinuity. The interaction of the two reflections causes the position of the null between the minor discontinuity and the generator to shift with respect to the position it would occupy if no minor discontinuity existed. Thus, information concerning the reflection coefficient of the minor discontinuity can be obtained by plotting the shift in this null as the line is lengthened.

The principles of this method are illustrated in Figure 4-11, which shows a coaxial system terminated in an open circuit. The minor discontinuity occurs somewhere near the end of the slotted section. A null in the standing-wave pattern between the minor discontinuity and the open circuit is designated Null 1; a null between the minor discontinuity and the generator is designated Null 2.

If the end of the line is extended or lengthened in small increments, the position of the nulls between the minor discontinuity and the end of the line moves in identical increments. Therefore the position of the nulls is a linear function of line length. However,

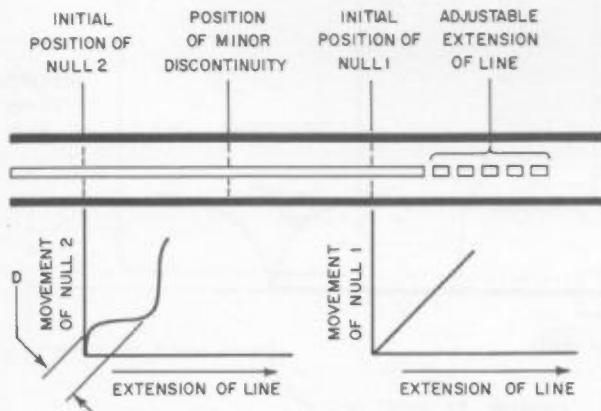

Figure 4-11. Effect of Minor Discontinuity on Location of Null When Line is Extended

the nulls on the other side of the minor discontinuity respond differently. Instead of moving linearly with extensions of the line, these nulls follow a nonlinear curve, as shown in Figure 4-12.

This nonlinear curve of null shift versus line length can be shown to be related to the reflection coefficient of the minor discontinuity.

From the peak-to-peak amplitude of the curve, the SWR of the discontinuity can be calculated. Reference planes which permit impedance corrections can also be determined by the location of the point where the curve crosses its median. An impedance measurement can then be corrected for the effect of this discontinuity by using the SWR and reference planes.

The null-shift method is usable in either coaxial or waveguide systems. It is especially helpful for high-accuracy impedance measurements in coaxial systems, as the impedance can be corrected for the errors introduced by the residual reflection of the connectors. In waveguide, however, the residual of the slotted section usually introduces negligible error.

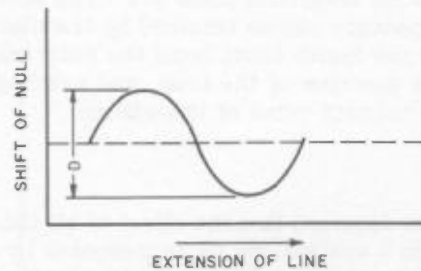

Figure 4-12. Null-Shift Curve Used to Obtain Phase Data

Residual-SWR Determination

The null-shift data as previously described is used to construct a null-shift curve. From the information contained on this curve, the residual SWR of the slotted line can be calculated and two reference planes located, one on each side of the discontinuity. The residual-reflection coefficient of the slotted line is given by

$$\rho_D = \sin \frac{\pi D}{\lambda}$$

where D is the peak-to-peak amplitude of the null-shift curve. The corresponding residual SWR is then

$$r = \frac{1 + \rho_D}{1 - \rho_D} \qquad r = \frac{1 + \sin \frac{\pi D}{\lambda}}{1 - \sin \frac{\pi D}{\lambda}}$$

or if D is small compared to λ

$$r \approx \frac{1 + \frac{\pi D}{\lambda}}{1 - \frac{\pi D}{\lambda}} \approx 1 + 2 \frac{\pi D}{\lambda} \approx 1 + \frac{2 \pi f D}{3 \times 10^4}$$

where f is in megacycles, λ and D are in centimeters.

Reference Planes

The reference planes shown in Figure 4-13 are such that the impedance, Z_1 , at reference plane 1-1 (generator side), and the impedance Z_2 , at reference plane 2-2 (load side), are related by the equation

$$Z_1 = r Z_2$$

where r is the equivalent lumped residual SWR for the slotted line *, Z_1 is the impedance determined by the slotted-line measurements including the errors due to the residual SWR, and Z_2 is the corrected value of the unknown load impedance translated along the line to the reference plane 2-2. The actual value of the impedance can be obtained by translating with the aid of the Smith chart from the reference plane 2-2 to the position of the load, and reading off the chart the correct value of impedance.

*Here it is assumed that the effect of all the discontinuities in a system can be represented by a single discontinuity positioned along the line by the location of the reference planes. These equivalent parameters will vary as a function of frequency; consequently the null-shift data and curve must be obtained for each frequency being considered.

Reference plane 1-1 is located at the position of the null on the slotted line when the null-shift curve crosses the median line with a positive slope. The position of this null can be obtained by relating the parameters on the graph to the original data that was obtained in the null-shift measurements. Reference plane 2-2 is obtained by shorting the slotted line and finding the corresponding minimum. If the distance between the reference plane 1-1 on the line and this minimum is X_1 , then the distance X_2 from the plane of the short to the reference plane 2-2 is found from the relation

$$\tan \frac{2 \pi X_1}{\lambda} = r \tan \frac{2 \pi X_2}{\lambda}$$

Impedance Correction

The measured value of the impedance or SWR can now be corrected for the residual SWR by using the Smith chart. The load is connected to the slotted line and the impedance measured as explained in Paragraph 4-5. The impedance is then referred to reference plane 1-1 on the Smith chart. The real and imaginary parts of the impedance at 1-1 are now divided by the residual SWR, r, found from the null-shift curve. This new impedance is the value of the load impedance referred to the reference plane 2-2. To find the load impedance at another reference plane, refer the impedance at 2-2 on the Smith chart to the desired reference plane. For example, to find the impedance of the load at the connector, refer the impedance at 2-2 a distance of X_2 toward the generator. The corrected value of the load SWR is obtained where the SWR impedance circle crosses the real axis on the Smith chart.

ACCURACY

The accuracy with which impedance or SWR can be obtained using the null-shift technique is determined

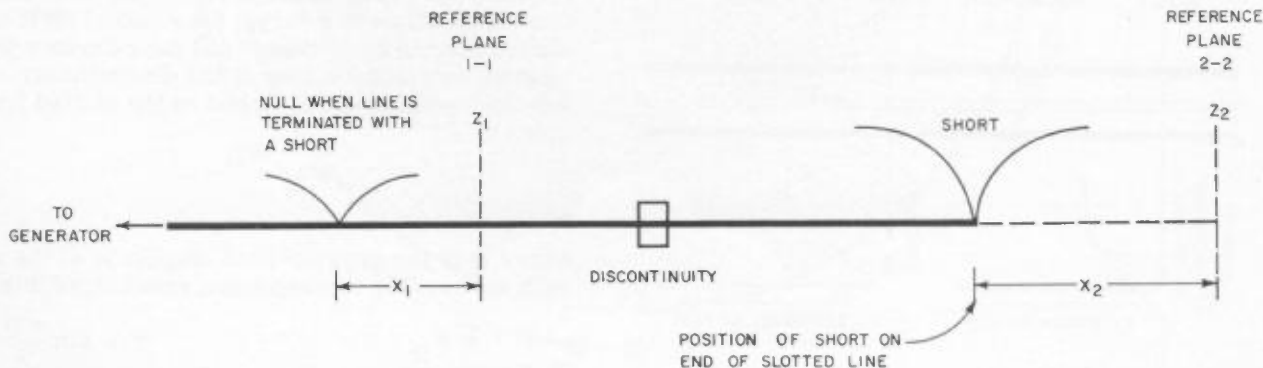

Figure 4-13. Position of Reference Planes on Slotted Line

by the accuracy with which null points can be located on the slotted lines. With the -hp- 805A Slotted Line, accuracies of ± 0.005 in SWR can be obtained. The accuracy is affected by the residual frequency modulation of the signal source, the presence of harmonics, frequency drift, and construction of the null-shift set. These effects should be minimized by the usual procedures.

PROCEDURE FOR DETERMINING RESIDUAL REFLECTION AND REFERENCE PLANES

Obtaining Null-Shift Data

- 1) Connect the equipment as shown in Figure 4-14.
- 2) Turn on the equipment, and let it warm up for 5 to 10 minutes.
- 3) Set the signal generator for the desired frequency.
- 4) Modulate the signal generator signal at 1 kc with a sine wave at about 70% when using a MOPA, and

with a square wave when using a klystron (use a 211A Square Wave Generator, or equivalent).

- 5) 415B Standing Wave Indicator Control Settings:
 RANGE switch to 50.
 INPUT SELECTOR switch to whichever CRYSTAL position gives the higher reading.
 METER SCALE switch to NORMAL.
 GAIN control to maximum.

- 6) Connect the shortest (0) length of center conductor to the slotted line under test. Attach the outer conductor snugly. Tap end of center conductor with the bakelite rod to ensure a snug fit. Then withdraw the rod several inches.

The shortest length of center conductor is designated 0. Numerical designations for the other lengths indicate how many millimeters longer they are than the length designated 0. The longest length is 320 mm longer than the zero length.

- 7) Adjust the signal generator attenuator to give an up-scale reading on the 415B. Adjust the slotted-line

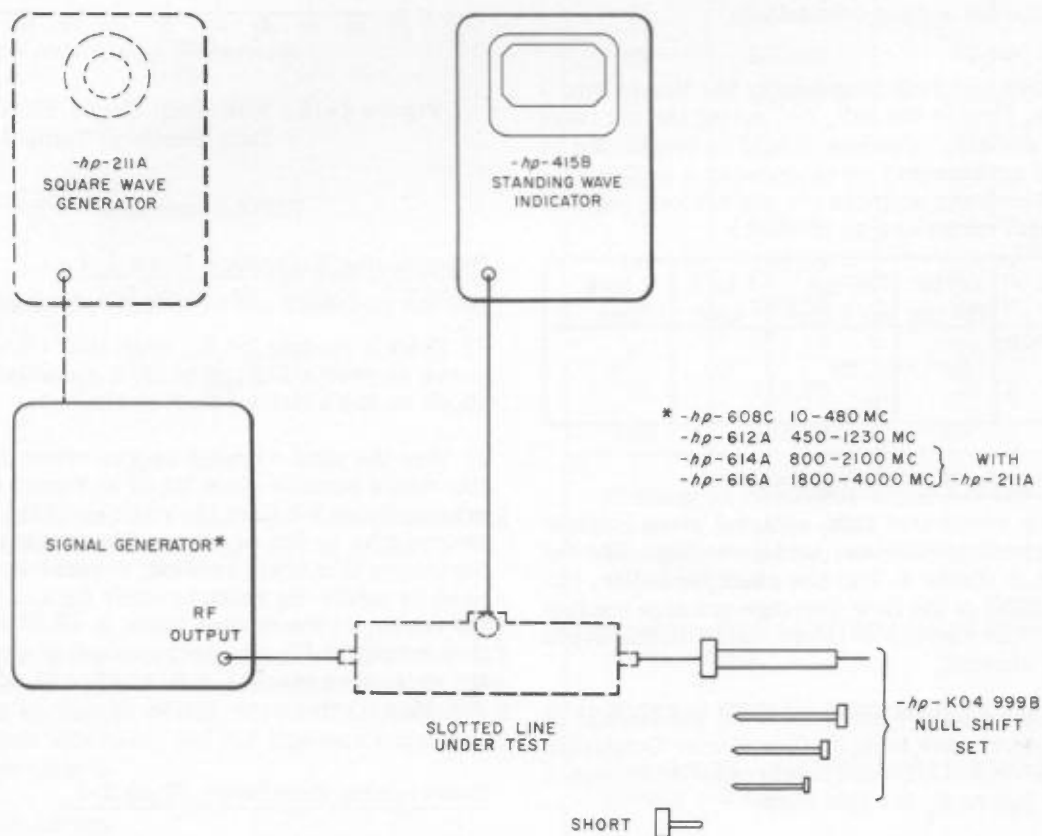

Figure 4-14. Residual SWR using Null-Shift Technique

probe for maximum penetration. Adjust the tuning control on the probe carriage to maximize the reading, sliding the carriage toward a null to keep the reading on scale.

8) Adjust the carriage for a minimum reading on the 415B. The probe is now at the null.

9) Check the depth of the null by setting the signal generator for 0-dbm output. A reading of about -60 at the null should appear on the 415B under these conditions (full scale on 60 range). Any large discrepancy may indicate such troubles as harmonics or fm from the generator or 1000-cycle ground currents. (Increase the generator output to maximum if null is not well above noise.)

10) If the null is still not well above noise, move the carriage to both sides of the null to obtain a convenient reading such as -50. Read and record the carriage positions. The average of the two readings is the position of the carriage when the probe is at the null.

11) Remove the outer conductor on the end of the slotted line; replace the center conductor with the next longer one; attach the outer conductor again; and tap as before for a snug connection.

The technique involves lengthening the line in small increments, finding the null, and noting the carriage position at the null. The line should be lengthened in successive increments up to at least a half wavelength. Increments suitable for the various regions of the coaxial range are as follows:

Range	500 to 750 mc	750 mc to 1 kmc	1 to 2 kmc	2 to 4 kmc
Increment, in mm	40	20	10	5

Constructing the Null-Shift Curve

1) To obtain convenient data, subtract some number from each carriage-position (scale) reading. For the data shown in Table 4-1 in the example below, the whole part (229) of the first carriage-position reading was used. The results (θ_1) are listed in the Scale Difference column.

2) To find the relative shift, subtract the amount of the increment at each step, θ_2 (see Center Conductor column, Table 4-1), from the corresponding Scale Difference figure θ_1 for that step.

3) Plot relative shift, $\theta_1 - \theta_2$, versus line increase, θ_2 , and draw a smooth curve through the points. At small SWR's, the curve will be very nearly a sine

wave with a period equal to one-half the wavelength at that frequency. See Figure 4-15.

4) Determine the peak-to-peak amplitude, D.

5) Calculate residual SWR (r) from the following expression:

$$r = 1 + \frac{2 \pi f D}{3 \times 10^5}$$

where D is in millimeters, f in megacycles.

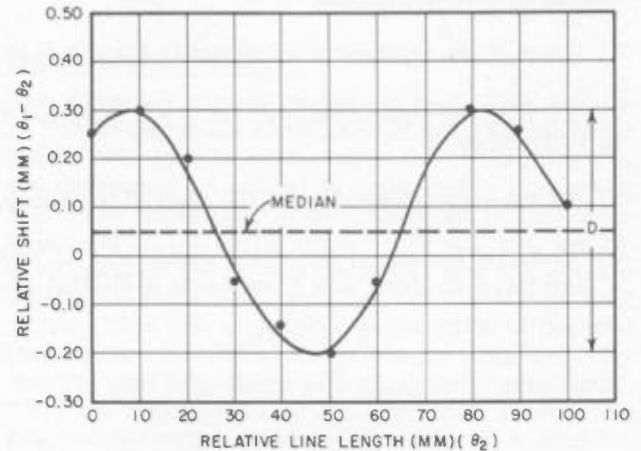

Figure 4-15. Null-Shift Curve Plotted from Data Shown in Table 4-1

Determining Reference Plane 1-1

Use the null-shift curve, to find reference plane 1-1:

1) Draw a median for the null-shift curve. For the curve shown in Figure 4-15, the median occurs at +0.05 on the relative shift scale.

2) Note the point where the curve crosses the median line with a positive slope (at 65 in Figure 4-15). Reference plane 1-1 is at the position of the probe corresponding to the scale reading at this point. To determine this scale reading, reverse the procedure used to obtain the relative-shift figures for plotting the curve; as the median value is +0.05 at a relative line length of 65, the corresponding scale reading for reference plane 1-1 is $+0.05 + 65.00 + 229.00 = 294.05$.

Determining Reference Plane 2-2

1) Short the slotted line with Shorting Plug 803A-76G or Shorting Jack 8A-76H (supplied with the -hp- 805A Slotted Line).

2) Find the null. In the measurements used as an example, a null was found at 286.60.

Let R_s be the scale reading corresponding to the null when the line is terminated in a short, and R_1 be the scale reading corresponding to reference plane 1-1. Then $X_1 = R_1 - R_s$.

3) Determine distance X_1 : $R_s = 286.60$, $R_1 = 294.05$; $X_1 = 7.45$.

4) Compute X_2 from the expression

$$\tan \frac{2\pi X_1}{\lambda} = r \tan \frac{2\pi X_2}{\lambda};$$

$$\tan \frac{2\pi X_1}{\lambda} = \tan \frac{2\pi (7.45)}{150} = \tan 17.88^\circ$$

$$= 0.32261$$

$$r \tan \frac{2\pi X_2}{\lambda} = 0.32261$$

$$\tan \frac{2\pi X_2}{\lambda} = \frac{0.32261}{r}$$

$$= \frac{0.32261}{1.021}$$

$$= 0.31597$$

$$\frac{2\pi X_2}{\lambda} = \arctan 0.31597$$

$$= 17.535^\circ \text{ or } \frac{(17.535)}{360} 2\pi \text{ rad.}$$

$$X_2 = \frac{(17.535)(150)}{360}$$

$$= 7.31 \text{ mm.}$$

Plane 2-2 is located 7.31 mm beyond the plane of the short placed on the connector.

Example:

The figures in the work sheet shown as Table 4-1 were obtained while determining the residual SWR of an 805A by means of the null-shift technique. A 2-kmc signal was used, and the line was extended in 10-mm increments.

1) Scale Readings

The zero length was connected to the female end of the 805A, and a null was located with the carriage at

229.25. The next center conductor used was the extender designated 10. A null was found at 239.30. Center conductor 20 was used next, and a null was found at 249.20. The line was extended in 10-mm increments up to 100. Readings obtained are shown in the Scale Reading column, Table 4-1.

2) Scale Difference (θ_1)

Convenient numbers to work with were obtained by subtracting 229 from each scale reading.

3) Relative Shift

The incremental increase (θ_2) was subtracted from the corresponding Scale Difference (θ_1) to find the relative shift.

TABLE 4-1. TYPICAL WORK SHEET, NULL-SHIFT TECHNIQUE

Center Conductor θ_2	Scale Reading	Scale Difference θ_1	Relative Shift $\theta_1 - \theta_2$
0	229.25	0.25	+0.25
10	239.30	10.30	+0.30
20	249.20	20.20	+0.20
30	258.95	29.95	-0.05
40	268.85	39.85	-0.15
50	278.80	49.80	-0.20
60	288.95	59.95	-0.05
70	299.10	70.10	+0.10
80	309.30	80.30	+0.30
90	319.25	90.25	+0.25
100	329.10	100.10	+0.10

Reading at reference plane 1-1 (R_1) = 294.05

Reading when line is terminated in a short (R_s) = 286.60

Peak-to-peak amplitude (D) of null-shift curve = 0.50

Residual SWR (r) of slotted line = 1.021

Wavelength (λ) = 150 mm (signal frequency = 2 kmc)

Reference plane 2-2 is 7.31 mm beyond connector ($X_1 = 7.45$; $X_2 = 7.31$)

4) Null-Shift Curve

The plot made of relative shift versus relative line length is shown in Figure 4-15. Peak-to-peak amplitude, D, was found to be 0.50 mm.

5) Residual SWR

Where D is 0.5 and f is 2000, the expression for residual SWR (r) is

$$r = 1 + \frac{(2 \times 3.14) (2 \times 10^3) (0.5)}{3 \times 10^5} = 1.021$$

PROCEDURE FOR CORRECTING AN IMPEDANCE MEASUREMENT

NOTE

The values used as an example of the procedure are tabulated in Table 4-2.

1) Measure the SWR in the slotted line with the load of unknown impedance connected to the female end of the line. Assume the measured SWR is 1.38.

2) With the slotted line still terminated in the load, determine the position of a minimum (M₁). Then note the position of a second (adjacent) minimum (M₂) so the wavelength can be computed. Where M₁ is at 249.9 and M₂ is at 174.9 mm,

$$\lambda = 2 (249.9 - 174.9) = 150 \text{ mm}$$

3) Compute the distance in wavelengths (Δλ₁₁) from reference plane 1-1 (R₁) to minimum (M₁) obtained with the line terminated in the unknown load.

$$\begin{aligned} \Delta\lambda_{11} &= \frac{R_1 - M_1}{\lambda} \\ &= \frac{294.05 - 249.90}{150} = 0.2943 \end{aligned}$$

4) Starting at the center of the Smith chart, draw a circle with the measured SWR (1.38) as the radius. See Figure 4-16.

5) Starting at the minimum position (zero reactance) on the Smith chart proceed a distance Δλ₁₁ toward plane 1-1 and draw a radius. (In the measurement being used as an example, scale reading is increasing in the direction of the female end, and the reading for plane 1-1 is greater than for M₁; therefore "to-

ward plane 1-1" is toward the load.) Read the impedance at plane 1-1. (In Figure 4-16 the impedance reading at plane 1-1 is 1.292 + j0.224.)

6) Calculate the impedance at plane 2-2 from the expression

$$\begin{aligned} Z_{22} &= \frac{Z_{11}}{r} \\ &= \frac{1.292}{1.021} + j \frac{0.224}{1.021} = 1.265 + j0.219 \end{aligned}$$

Draw the new SWR circle and a radius through this point.

TABLE 4-2. IMPEDANCE-CORRECTION DATA

<u>Calibration Data on Line (female end, 2 kmc)</u>	
Residual SWR (r):	1.021
Scale reading at plane 1-1 (R ₁):	294.05 mm
Location of plane 2-2 (X ₂):	7.31 mm from plane of short
Location of null, line shorted (R _s):	286.60 mm
<u>Measurement Data on Load</u>	
SWR:	1.38
Scale reading, minimum M ₁ :	249.9 mm
Scale reading, minimum M ₂ :	174.9 mm
Wavelength (λ):	2 (M ₁ - M ₂) = 2(249.9 - 174.9) = 150 mm
<u>Distances</u>	
Δλ ₁₁ = $\frac{X_1}{\lambda} = \frac{R_1 - M_1}{\lambda} = \frac{294.05 - 249.90}{150}$	= 0.2943
Δλ ₂₂ = $\frac{X_2}{\lambda} = \frac{7.31}{150}$	= 0.0487
<u>Impedances</u>	
Plane 1-1 (Z ₁₁):	1.292 + j0.224
Plane 2-2 (Z ₂₂):	$\frac{Z_{11}}{r} = \frac{1.292}{1.021} + \frac{0.224}{1.021}$ = 1.265 + j0.219
Load (Z _L):	1.352 - j0.006

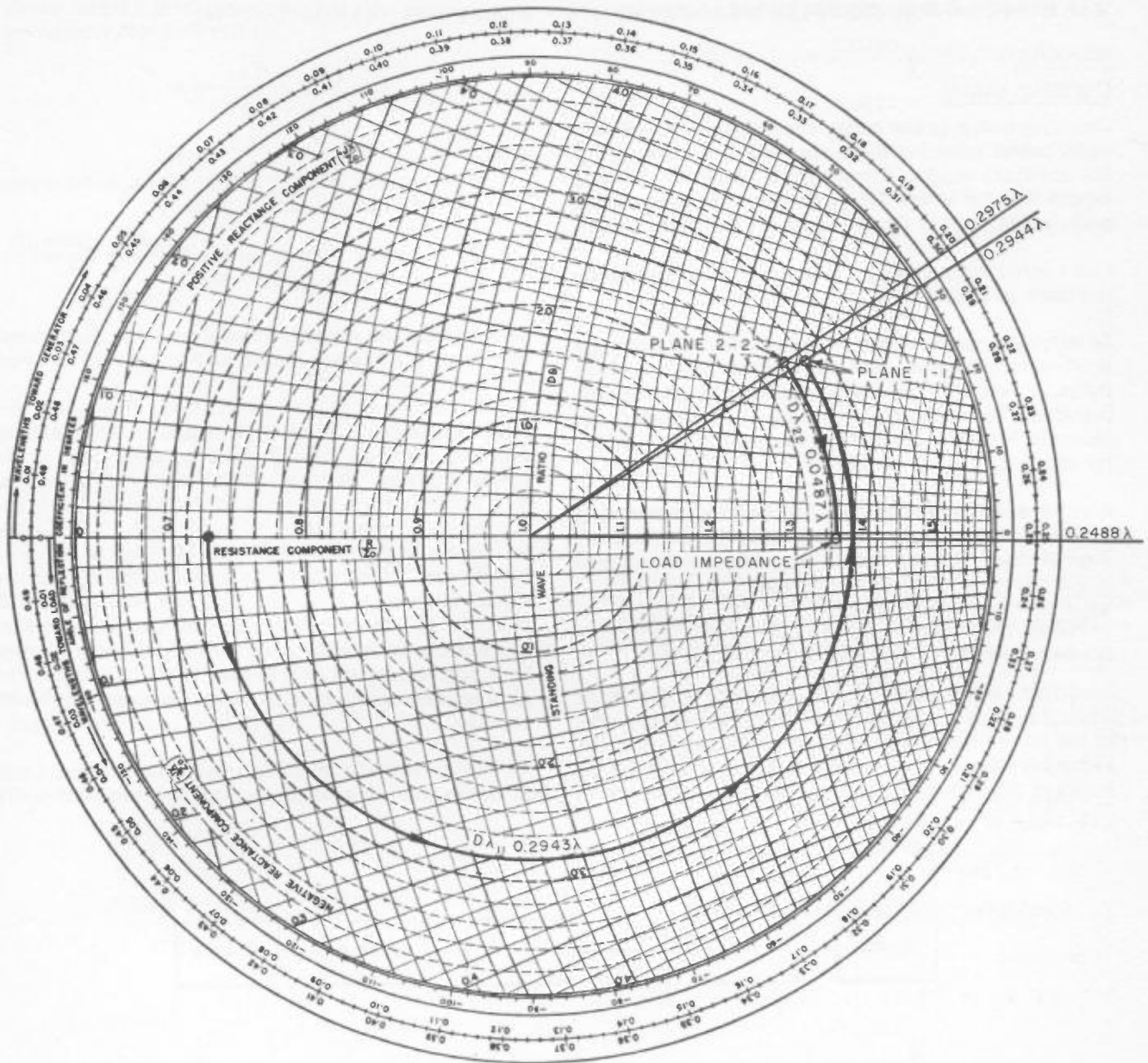

Figure 4-16. Smith Chart

7) Compute the distance in wavelengths ($\Delta \lambda_{22}$) from reference plane 2-2 to the load. This is distance X_2 computed in the subparagraph above, "Determining Reference Plane 2-2."

$$\Delta \lambda_{22} = \frac{X_2}{\lambda} = \frac{7.31}{150} = 0.0487$$

8) Starting at plane 2-2, proceed a distance of $\Delta \lambda_{22}$ toward the generator. Draw a radius.

9) The intersection of this radius and the SWR circle drawn in step 6 is the impedance of the load, referred to the plane of a short on the end connector.

As shown in Figure 4-16, the radius reading is 0.2488 (0.2975 minus 0.0487). The impedance of the load is 1.352 - j0.006.

4-7 DIRECTIONAL COUPLER MEASUREMENTS

GENERAL

Coupling Factor

Coupling factor is the ratio, expressed in db, of forward power entering the main guide to power out of the auxiliary guide. For example, a 20-db coupling means that for every 100 parts entering the forward main guide, 1 part flows out of the auxiliary guide.

One convenient method of measuring coupling factor is shown in Figure 4-17.

Briefly, the measurement is performed by setting a level on an indicator, such as the 415B Standing Wave Indicator, with the tuner adjusted for maximum power transfer. The coupler is then added in the system, as shown in Figure 4-17, and the decrease on the indicator is noted.

A square-law detector can be used for measuring coupling factors up to 30 db with negligible error. Beyond that, a linear-detection system as described in Paragraph 3-3 is recommended.

Directivity

Directivity is the ratio, expressed in db, of the power flowing in the forward direction in the secondary arm to the power flowing in the reverse direction in the secondary arm, when power is flowing only in the forward direction in the main guide. As shown in

Figure 4-18, the directivity is:

$$D = 10 \log \frac{P_1}{P_2}$$

where

P_1 = power flowing in the forward direction in the secondary arm

P_2 = power flowing in the reverse direction in the secondary arm.

To measure the directivity of waveguide directional couplers, the system shown in Figure 4-19 is used.

First, a short is placed on the line. The short reflects all of the incident power and permits setting a power level on the indicator proportional to the power entering the forward secondary termination. The short is then replaced with a sliding load, and the indicator sensitivity is increased. The sliding load permits the reflection from the load to be identified from the directivity signal. If the directivity signal and signal from the load are less than 30 db from the reference setting, the detector (square law) will operate in the noise. Increasing the source power by a known amount overcomes this difficulty. The sliding load is adjusted for maximum and minimum signals.

As the directivity and load reflection signals add in phase to give a maximum signal, and add out of

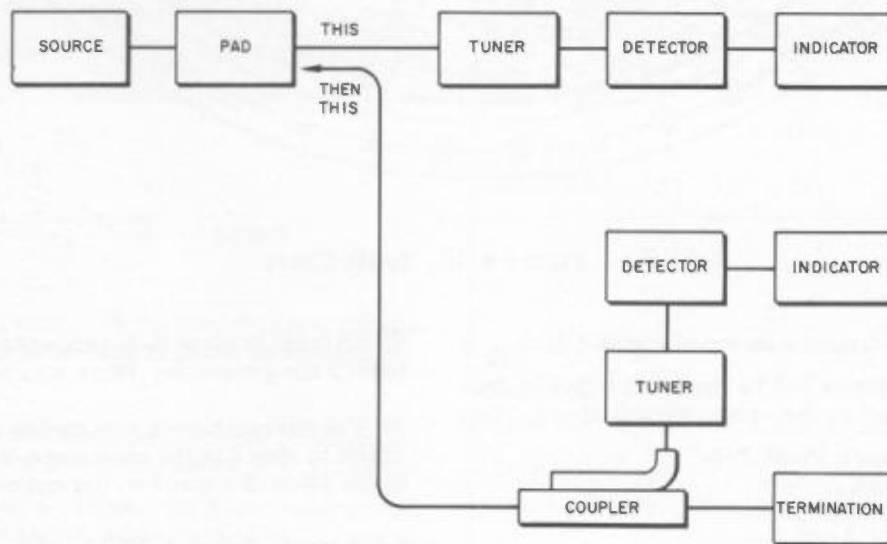

Figure 4-17. Measurement of Coupling Factor

phase to give a minimum signal, the following expressions can be written:

$$\rho_{\max} = D + \rho_L$$

$$\rho_{\min} = D - \rho_L \text{ or } \rho_L - D$$

Solving for D and ρ_L

$$D \text{ or } \rho_L = \frac{\rho_{\max} + \rho_{\min}}{2}$$

$$D \text{ or } \rho_L = \frac{\rho_{\max} - \rho_{\min}}{2}$$

The directivity could be equal to either expression depending on its magnitude compared with the load reflection. The directivity can be uniquely determined by performing the same measurement on another coupler or by using another sliding load on the original coupler.

For example, assume that the maximum and minimum readings are -30.6 and -36.3 db respectively. Figure 4-20 can be used to determine the two signals, or they can be calculated as follows:

The voltage ratios are

$$\text{Antilog} \left(\frac{-30.6}{20} \right) = 0.0295$$

$$\text{Antilog} \left(\frac{-36.3}{20} \right) = 0.0153$$

Substituting into the formulas and solving,

$$D \text{ or } \rho_L = \frac{0.0295 + 0.0153}{2} = 0.0224$$

$$\begin{aligned} \text{In db} &= 20 \log 0.0224 \\ &= -33 \text{ db} \end{aligned}$$

$$D \text{ or } \rho_L = \frac{0.0295 - 0.0153}{2} = 0.00706$$

$$\begin{aligned} \text{In db} &= 20 \log 0.00706 \\ &= -43 \text{ db} \end{aligned}$$

When another sliding load was used, D and ρ_L were -43 db and -35 db. Hence, the directivity is -43 db.

The measurement of directivity in coaxial couplers requires a different technique, as sliding loads are not available for all frequencies. A complete discussion of this technique is found in the Addenda.

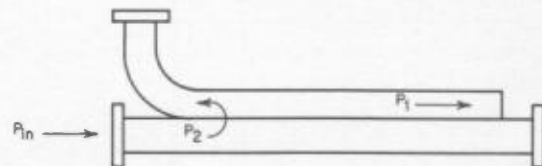

Figure 4-18. Directivity Variables

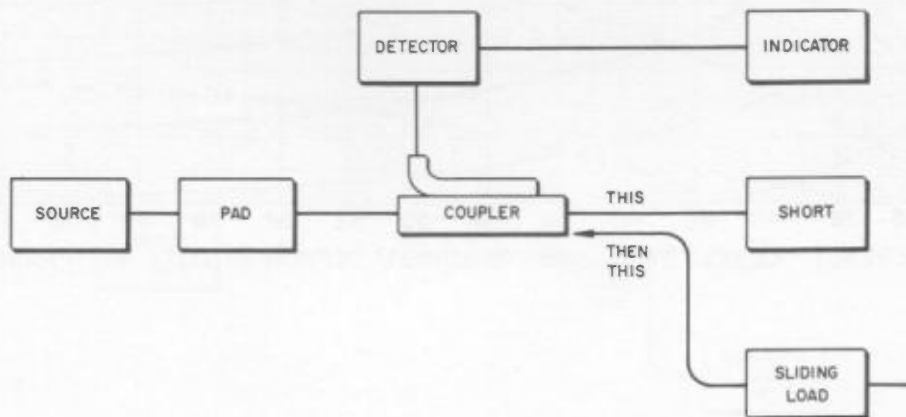

Figure 4-19. Measurement of Directivity

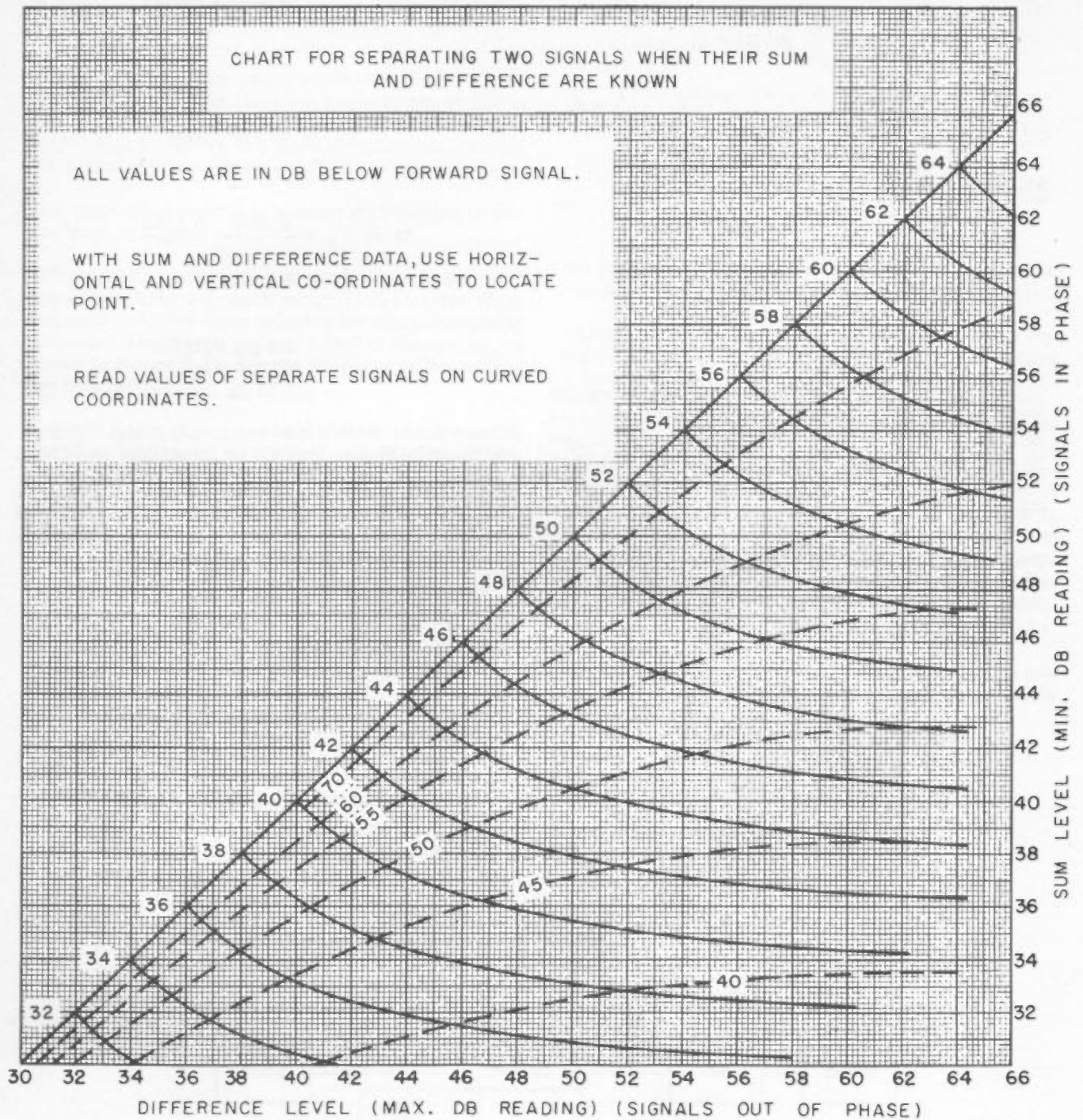

Figure 4-20. Signal-Separation Chart

4-8 REFLECTION-COEFFICIENT MEASUREMENTS WITH REFLECTOMETER SYSTEMS

GENERAL

The reflection coefficient of a load can be measured by a number of different systems. Generally the method for measuring it uses one or more directional couplers to sample the incident and reflected power. One of the simplest methods is shown in Figure 4-21.

To measure the reflection coefficient of the load, a short is placed on the output of the coupler, and a reference level is set on the indicator. The short is then replaced with the test load, and the corresponding indicator level noted.

The reflection coefficient is then the ratio of the second voltage to the first.

As the analysis of errors in a reflectometer system is quite complicated, the paragraph below, "Accuracy," completely analyzes a simple system to show the relation between the measured reflection coefficient and the true coefficient. Typical values for a waveguide system are also given. The paragraph "Superior Reflectometer Systems" describes a system wherein reflection coefficients can be measured with errors of less than 1%.

ACCURACY

Because of the number of variables in a reflectometer system, the error analysis is somewhat complicated. Some of the system imperfections which must be considered are the directivity of the coupler, SWR of the coupler and generator, and the transmission coefficient through the coupler. The system shown in Figure 4-21 can be analyzed by means of the signal-flow graph shown in Figure 4-22. (The flow-graph technique is explained in the Addenda.)

The relations between the various "effective" coefficients and the actual scattering coefficients of the coupler and the reflection coefficient of the detector (Γ_0) are as follows:

$$\Gamma_i = S_{11} + \frac{S_{13} S_{31} \Gamma_0}{1 - S_{33} \Gamma_0} \approx S_{11}$$

$$\Gamma_o = S_{22} + \frac{S_{23} S_{32} \Gamma_0}{1 - S_{33} \Gamma_0} \approx S_{22}$$

$$C = \frac{S_{32}}{1 - S_{33} \Gamma_0} \approx S_{32}$$

$$D = \frac{S_{31}}{S_{32}}$$

$$T = S_{21} + \frac{S_{31} S_{23} \Gamma_0}{1 - S_{33} \Gamma_0} \approx S_{21}$$

The ratio of output voltage at the detector to input voltage from the generator with a load on the coupler output is:

$$\frac{e_o}{e_{iL}} = \frac{CD(1 - \Gamma_L \Gamma_0) + CT\Gamma_L}{1 - \Gamma_i \Gamma_G - T^2 \Gamma_G \Gamma_L + \Gamma_i \Gamma_0 \Gamma_G \Gamma_L} \quad (1)$$

With a short on the primary-arm output of the coupler, the expression becomes

$$\frac{e_o}{e_{iS}} = \frac{CD(1 - \Gamma_0 e^{j\theta}) + CT e^{j\theta}}{1 - \Gamma_i \Gamma_G - T^2 \Gamma_G e^{j\theta} - \Gamma_0 e^{j\theta} + \Gamma_i \Gamma_0 \Gamma_G e^{j\theta}} \quad (2)$$

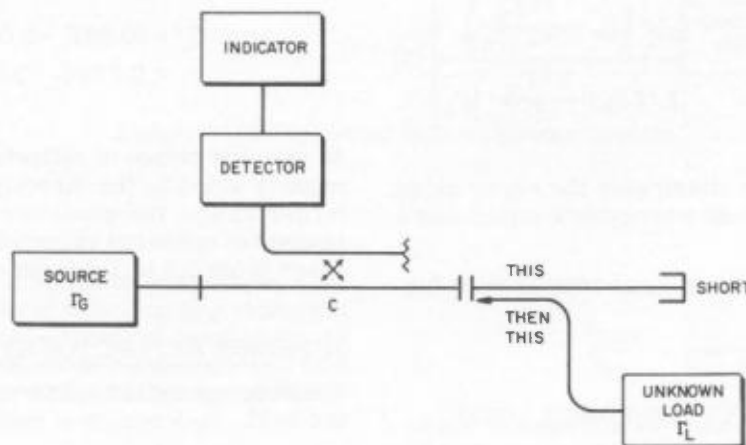

Figure 4-21. Reflection-Coefficient Measurement

where θ is the phase angle of the short. The ratio of the magnitudes of these expressions is the measured load reflection coefficient, Γ_L' :

$$\begin{aligned} |\Gamma_L'| &= \left| \frac{CD(1-\Gamma_o\Gamma_L) + CT\Gamma_L}{1-\Gamma_i\Gamma_G - T^2\Gamma_G\Gamma_L - \Gamma_o\Gamma_L + \Gamma_i\Gamma_o\Gamma_G\Gamma_L} \right| \\ &= \left| \frac{1-\Gamma_i\Gamma_G - T^2\Gamma_G e^{j\theta} - \Gamma_o e^{j\theta} + \Gamma_i\Gamma_o\Gamma_G e^{j\theta}}{CD(1-\Gamma_o e^{j\theta}) + CT e^{j\theta}} \right| \\ &= |\Gamma_L| \cdot \left| \frac{1 + \frac{D}{(\Gamma - D\Gamma_o)\Gamma_L}}{1 + \frac{D}{(\Gamma - D\Gamma_o)e^{j\theta}}} \right| \cdot \left| \frac{1 - \left(\Gamma_o + \frac{T^2\Gamma_G}{1-\Gamma_i\Gamma_G}\right) e^{j\theta}}{1 - \left(\Gamma_o + \frac{T^2\Gamma_G}{1-\Gamma_i\Gamma_G}\right) \Gamma_L} \right| \quad (3) \end{aligned}$$

As each of the various phase angles can have any value, the worst possible errors can be obtained by appropriate choice of signs. From this point on, the symbols indicate only magnitudes. The $D\Gamma_o$ terms are insignificant with high-quality components. The maximum and minimum Γ_L' 's can be rewritten with negligible error as follows:

$$\begin{aligned} \text{MAX } \Gamma_L' &= \Gamma_L \left[1 + \frac{D}{T} \left(\frac{1}{\Gamma_L} + 1 \right) \right] \cdot \\ &\quad \left[\frac{1 + \left(\Gamma_o + \frac{T^2\Gamma_G}{1-\Gamma_i\Gamma_G} \right)}{1 - \left(\Gamma_o + \frac{T^2\Gamma_G}{1-\Gamma_i\Gamma_G} \right) \Gamma_L} \right] \quad (4) \end{aligned}$$

$$\begin{aligned} \text{MIN } \Gamma_L' &= \Gamma_L \left[1 - \frac{D}{T} \left(\frac{1}{\Gamma_L} + 1 \right) \right] \cdot \\ &\quad \left[\frac{1 - \left(\Gamma_o + \frac{T^2\Gamma_G}{1-\Gamma_i\Gamma_G} \right)}{1 + \left(\Gamma_o + \frac{T^2\Gamma_G}{1-\Gamma_i\Gamma_G} \right) \Gamma_L} \right] \quad (5) \end{aligned}$$

The following example illustrates the error using typical values for a 20-db waveguide coupler and a signal generator:

$$D = 0.01$$

$$\Gamma_o = 0.025$$

$$T = 0.99 \text{ (INCLUDES WAVEGUIDE LOSS)}$$

$$\Gamma_G = 0.20$$

$$\Gamma_i = 0.025$$

$$\begin{aligned} \text{MAX } \Gamma_L' &= \Gamma_L \left[1 + \frac{0.01}{0.99} \left(\frac{1}{\Gamma_L} + 1 \right) \right] \cdot \\ &\quad \left[\frac{1 + \left(0.025 + \frac{(0.98)(0.20)}{1-0.005} \right)}{1 + \left(0.025 + \frac{(0.98)(0.20)}{1-0.005} \right) \Gamma_L} \right] \\ &= \Gamma_L \left[1.01 + \frac{0.01}{\Gamma_L} \right] \cdot \left[\frac{1 + 0.222}{1 - 0.222\Gamma_L} \right] \\ \text{MIN } \Gamma_L' &= \Gamma_L \left[0.99 - \frac{0.01}{\Gamma_L} \right] \cdot \left[\frac{1 - 0.222}{1 + 0.222\Gamma_L} \right] \end{aligned}$$

At values of Γ_L near 1,

$$\text{MAX } \Gamma_L' = \Gamma_L (1.02) \left(\frac{1.222}{0.778} \right) = 1.60 \Gamma_L$$

$$\text{MIN } \Gamma_L' = \Gamma_L (0.98) \left(\frac{0.778}{1.222} \right) = 0.624 \Gamma$$

At values of Γ_L near 0.1:

$$\text{MAX } \Gamma_L' = \Gamma_L (1.11) \left(\frac{1.222}{0.9778} \right) = 1.39 \Gamma_L$$

$$\text{MIN } \Gamma_L' = \Gamma_L (0.89) \left(\frac{0.778}{1.0222} \right) = 0.677 \Gamma_L$$

At values of Γ_L near 0:

$$\begin{aligned} \text{MAX } \Gamma_L' &= (1.01\Gamma_L + 0.01)(1 + 0.222) \\ &= 1.234\Gamma_L + 0.0122 \end{aligned}$$

$$\begin{aligned} \text{MIN } \Gamma_L' &= (0.99\Gamma_L - 0.01)(1 - 0.222) \\ &= 0.770\Gamma_L - 0.00778 \end{aligned}$$

At very low values of reflection the error is approximately equal to the directivity of the coupler. At larger values the generator reflection coefficient causes the measured reflection coefficient to be in the range from 0.6 to 1.6 times the true value.

SUPERIOR REFLECTOMETER SYSTEM

The superior reflectometer system is shown in Figure 4-23.

Briefly, a sliding load of low SWR is placed on the output, and tuner T_x is adjusted for a constant indica-

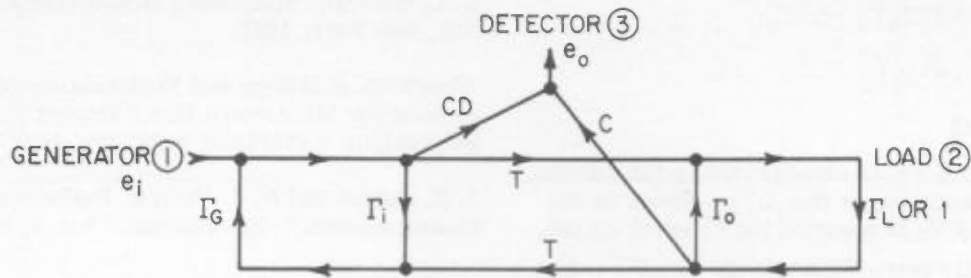

- Γ_G = generator reflection coefficient
- Γ_L = unknown reflection coefficient
- Γ_i = effective input reflection coefficient of the coupler
- Γ_o = effective reflection coefficient at output coupler
- C = effective coupling factor of the coupler
- D = effective directivity of the coupler.
- T = effective transmission coefficient through coupler

Figure 4-22. Signal-Flow-Graph for Reflection-Coefficient Measurement System

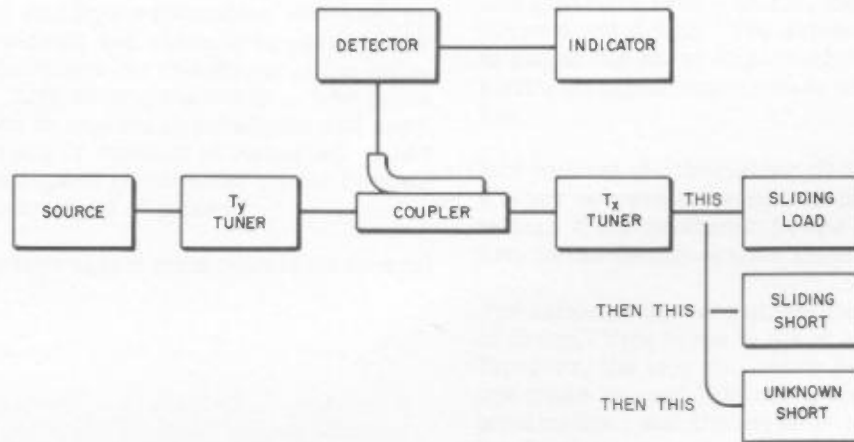

Figure 4-23. Superior Reflectometer System

tor reading as the load is moved back and forth. The sliding load is then replaced with a sliding short, and tuner T_y is adjusted for a constant reading as the short is moved. The reflection coefficient of a load is now measured as described in the paragraph "General" for the simple system in Figure 4-21.

The analysis of this system can be summarized as follows. The expression for the ratio of detector out-

put to generator input is

$$\frac{e_{OUT}}{e_{IN}} = \frac{A\Gamma_L + B}{C\Gamma_L + D}$$

which is equation (1) rewritten in simpler form where

$$A = CT - CD\Gamma_o$$

$$B = CD$$

$$C = \Gamma_i \Gamma_o \Gamma_G - T^2 \Gamma_G$$

$$D = 1 - \Gamma_i \Gamma_G$$

For a small Γ_L , $A \Gamma_L$ is comparable in magnitude to B, while D is much larger than $C \Gamma_L$. Hence as the load is moved and T_x is adjusted for constant output, B is made virtually zero. With a large Γ_L , $C \Gamma_L$ and D are comparable in magnitude. As the short is moved and T_y is adjusted for constant output, C is made virtually zero. Hence, the output is proportional to Γ_L after these preliminary adjustments are completed. Of course, the system requires that the generator output remain constant during the course of a measurement.

4-9 REFERENCES

- Arthur Fong, Direct Measurement of Impedance, "-hp- Journal," vol. 1, No. 8.
- E. L. Ginzton, "Microwave Measurements," McGraw-Hill, New York, 1957.
- "Handbook of Design and Performance of Cable Connectors for Microwave Use," Report No. R-520-56, Polytechnic Institute of Brooklyn, New York.
- J. K. Hunton and N. J. Pappas, Reflection Coefficient Measurements, "-hp- Journal," vol. 6, Nos. 1 and 2.
- J. K. Hunton and W. B. Wholey, The Perfect Load and the Null Shift, "-hp- Journal," vol. 3, Nos. 5 and 6.
- Howard Poulter, Coaxial Coupler Directivity Measurements, "-hp- Journal," vol. 8, Nos. 9 and 10.
- W. B. Wholey, Good Practices in Slotted Line Measurements, "-hp- Journal," vol. 3, Nos. 1 and 2.
- Wind and Rapaport, "Handbook of Microwave Measurements" (2nd ed.), Polytechnic Institute of Brooklyn, New York, 1955.

SECTION V POWER

5-1 GENERAL DESCRIPTION

Microwave power is commonly measured by either of two systems. With the calorimetric method, a mass is heated by the rf power to be measured. Another equal mass is heated with dc or af power until it is at exactly the same temperature as the mass heated by the rf power. The heating effect of the dc or af power is assumed to be the same as that of the rf power. Therefore, a measure of the dc or af power required for equal mass temperature is a measure of the rf power. The dc or af power is measured either with a voltmeter and ammeter, when a dry calorimeter is used, or automatically with a self-balancing bridge, when the -hp- 434A Power Meter is used.

The other method employs a bolometer which operates in a bridge circuit and changes rf energy into heat energy. This causes the resistance of the bolometer to change, unbalancing the bridge. The audio or dc power which is applied to rebalance and keep the bolometer resistance constant is measured. Audio or dc power is assumed to have the same heating effects on the element as rf power.

Any microwave power measurement contains several sources of error:

- 1) Mismatch loss
- 2) RF loss
- 3) Substitution error
- 4) Error in substituted-power measurement.

The first two are always losses and result in readings too low. The last two can result in errors in either direction. Mismatch loss results when impedance mismatch occurs. When the impedance of the load is not the conjugate of the source, part of the signal is reflected from the load and is lost.

Mismatch Loss

There are two points to be considered when the power output of a source is measured. One is the power

which the source will deliver to a load of unity SWR; the other is the maximum amount of power which a source will deliver. Measuring the latter requires a power meter with an input which provides a conjugate match. Inasmuch as the chance of the power-meter input providing a unity SWR or conjugate match is negligible, mismatch error results. If the generator is not matched to the line, it is not possible to state the mismatch error if the two SWR's are known, because the relative phase of the two impedances at any point in the line is unknown. Consequently, it is possible to state only the limits of the loss corresponding to the best and worst relative phases. A chart showing mismatch loss versus SWR appears in Section III, Figure 3-4. For example, if the source and load have SWR's of 1.5, the possible loss is between 0 and 0.7 db. The existence of this ambiguity is one of the most important reasons for reducing SWR's on signal sources to as close to unity as possible.

One method of eliminating all ambiguity is to insert a tuner between the source and the power meter and to tune it for maximum power transfer. The tuner then presents a conjugate impedance to the source.

For either measurement, the tuner adds a new source of error. This error is the rf loss through the tuner. However, the loss can easily be evaluated. Briefly, one tuner is used between a slotted line and a good termination, and the tuner is adjusted to establish the SWR at which the loss is to be evaluated. A second tuner, identical to the first, is then inserted between the slotted line and the first tuner and is used to reduce the SWR to unity. If the adjustments are carefully made, the loss through the two tuners will be twice that through one of them. The attenuation of the two-tuner combination can then be measured. At normal SWR's, good tuners rarely introduce a loss of more than a few percent, so that great precision in this measurement is not required.

RF Loss

The second source of error, rf loss, refers to the loss in the rf portion of the power meter. In general, losses occur in transmission-line sections, sharp

corners, capacitor dielectrics, finger contacts, etc., which are not measured. These losses are found in all bolometer mounts and in most calorimeters. The rf loss is so difficult to measure that it is almost universally ignored in the published specifications on commercial equipment. A method has been developed by the National Bureau of Standards for the measurement of the efficiency of bolometer mounts by means of impedance measurements, but it is quite complex in application and works only for barretters. This method is given in the Addenda. Calorimetric power meters, in which the temperature rise of the whole mount is sensed, eliminate this source of error, but most calorimeters sense the temperature rise of only the actual resistance load.

Substitution Error

Substitution error occurs when the heating effects of rf and low-frequency power are not the same. In general, this error is negligibly small in calorimeters. In barretters and thermistors the best measurements made to date indicate that it is less than 1% up to at least X-band (8.2 to 12.4 kmc). Above X-band, the assumption is generally made that the error is negligible if the bolometer is scaled down in size in proportion to the shorter wavelengths involved. Frequently the rf loss and substitution error are regarded as one loss, called "calibration factor." NBS now determines the "calibration factor" for bolometer mounts in X-band, S-band (2.60 to 3.95 kmc), and coax mounts. Good bolometer mounts have calibration factors ranging between 0.85 and 0.98.

Error in Substituted-Power Measurement

Another source of error can occur in the measurement of the substituted dc or low-frequency power, or the power used to calibrate an instrument. Here the accuracy of the measurement depends upon the accuracy of the ac or dc equipment available.

Either the 430C Power Meter or K04 999A Bolometer Bridge can be used with an appropriate bolometer to measure rf power. The choice of instrument depends upon the range and desired accuracy. The 430C measures power up to 10 milliwatts with an accuracy of $\pm 5\%$ full scale. The power-measuring capabilities of the Bolometer Bridge are limited by the power range of the bolometer and associated ac and dc instrumentation. Powers up to 25 milliwatts in coax systems and up to 12 milliwatts in waveguide can be measured with existing -hp- bolometers. The accuracy of measurement with the Bridge depends entirely upon the ac and dc instrumentation.

The 434A Calorimetric Power Meter is used to measure power from 10 milliwatts to 10 watts. For highest accuracy the 434A is calibrated at dc with the

K01 434A Test Set. The obtainable accuracy is then approximately 1% at 1 kmc to 4% at 12.4 kmc.

Frequently, it is necessary to measure power that is larger than can be safely handled with the power meter. The power can be reduced to an acceptable level for measurement by using a calibrated directional coupler, an attenuator, or both.

The secondary arm of a coupler samples the power in the primary arm at a ratio determined by the coupling factor. If the power meter is connected to the secondary arm, the source power will be reduced by the coupling factor. The coupling factor is usually expressed in db.

The power in the primary arm (see Figure 5-1) is given by the expression:

$$P_I = \left(\text{Antilog} \frac{C_F}{10} \right) (\text{Power Meter Reading})$$

where

C_F is the coupling factor in db.

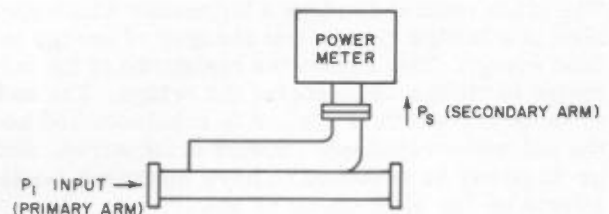

Figure 5-1. Power Measurement Variables

A variable or fixed attenuator can also be used to reduce the power level. (See Figure 5-2.) Variable attenuators have a loss at the 0-db setting which must be included for most accurate measurements.

The power entering the attenuator is given by the expression:

$$P_I = \left[\text{Antilog} \frac{(A + A_I)}{10} \right] (\text{Power Meter Reading})$$

where

A is the setting of the attenuator in db
 A_I is the loss of the attenuator in db at the 0-db setting.



Figure 5-2. Power Level Reduction

5-2 POWER MEASUREMENTS WITH THE 430C POWER METER

GENERAL

The 430C Power Meter with a suitable bolometer mount automatically measures power up to 10 milliwatts. The design is based on the assumptions that the bolometer element is not a frequency-sensitive device, and that equivalent amounts of dc or rf power produce the same effect on the resistance of the element. The bolometer element forms one leg of a self-balancing bridge balanced for the operating resistance of the element, usually 100 or 200 ohms. The power meter contains a bridge, a 10.8-kc oscillator, a dc-bias circuit, and a meter circuit.

Initially, the bolometer element is connected to the instrument bridge circuit but is not placed in an rf field. The bolometer bridge is very nearly balanced when the element changes from its cold resistance to its operating resistance. The change takes place as the element absorbs power from the oscillator and dc power from the bias circuit.

When rf power is applied to the bolometer, the bridge is unbalanced, forcing the oscillator to supply a different amount of af power to the bolometer for the same operating resistance. This change of af power is measured and displayed on the meter.

ACCURACY

The accuracy of power measurements with the 430C depends upon mismatch loss, rf loss, substitution

error, and error in measuring substituted power. The substituted power is measured with an accuracy of $\pm 5\%$ with the 430C. This specification includes an adequate safety factor. A recently calibrated 430C generally measures power with an accuracy of $\pm 3\%$ or better.

MEASUREMENT SETUP

The following paragraphs describe power measurements with the 430C Power Meter and 477B or X487B Thermistor Mount. The 477B has a frequency range from 10 mc to 10 kmc, while the X487B has a range from 8.2 to 12.4 kmc. Power up to 10 milliwatts can be measured with either mount alone. The measurable range of power can be increased, however, by employing precision attenuators or directional couplers ahead of the mount. A system extending the range of the X487B Thermistor Mount is also shown.

PRELIMINARY PROCEDURE

- 1) Select the appropriate equipment to measure the source power. Align the waveguide carefully, as any misalignment will cause error. Do not apply rf power at this time.
- 2) 430C Power Meter Control Settings:
 - BIAS CURRENT control to OFF.
 - COARSE and FINE controls completely counter-clockwise.
 - RES. switch to proper bolometer operating resistance (200 for 477B, 100 for X487B).
 - COEF. switch to NEG. for thermistors (POS. for barretters).
 - POWER RANGE switch to the proper range for the power to be measured. Set to 10 MW for measurements above 10 mw.
- 3) Connect the 430C Power Meter to 115-volt, 50/1000 -cps power. Turn on the Power Meter and allow it to

TABLE 5-1. ESTIMATED ACCURACY OF POWER MEASUREMENT IN COAX SYSTEMS, 10 MC TO 5 KMC (POSSIBLE ERRORS)

Range		430C Power Meter	477B Mount Efficiency (Estimated)	H01 872A Tuner Loss	Total
0.1 mw	High	+5%	-1%	-1%	+3%
to					
10 mw	Low	-5%	-3%	-2%	-10%

* The H01 872A Tuner generally is not used below 500 mc.

TABLE 5-2. ESTIMATED ACCURACY OF POWER MEASUREMENT IN WAVEGUIDE (POSSIBLE ERRORS)

Range		430C Power Meter	X487B Mount Efficiency (estimated)	X870A Tuner Loss	X752A Calibration	X382A Calibration	Total
0.1 mw to 10 mw	High	+5%	-2%	-1%			+2%
	Low	-5%	-4%	-2%			-11%
Extended Range	High	+5%	-2%	-2%	+2%	+2.3% to +4.6%	Add instrument errors for equipment used.
	Low	-5%	-4%	-4%	-2%	-2.3% to -4.6%	

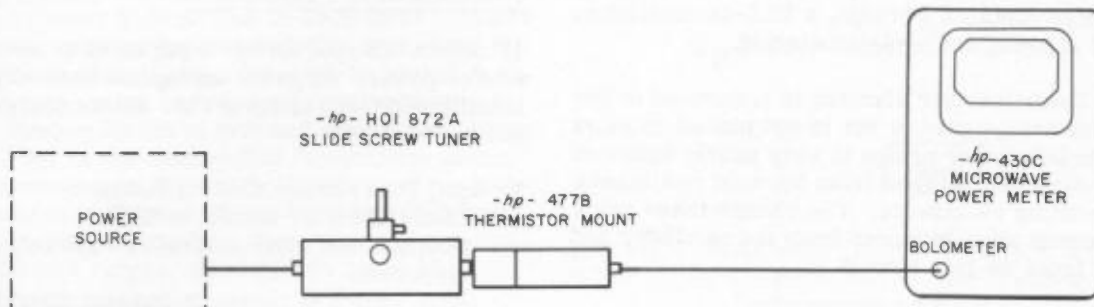

Figure 5-3. Power Measurements in Coax Systems

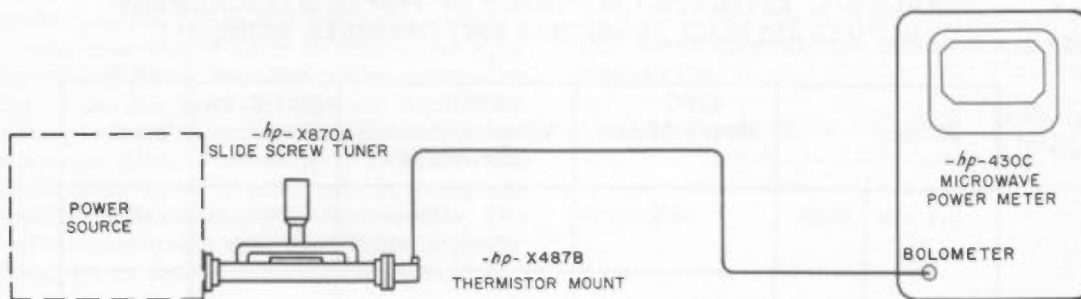

Figure 5-4. Power Measurements in X-Band Waveguide

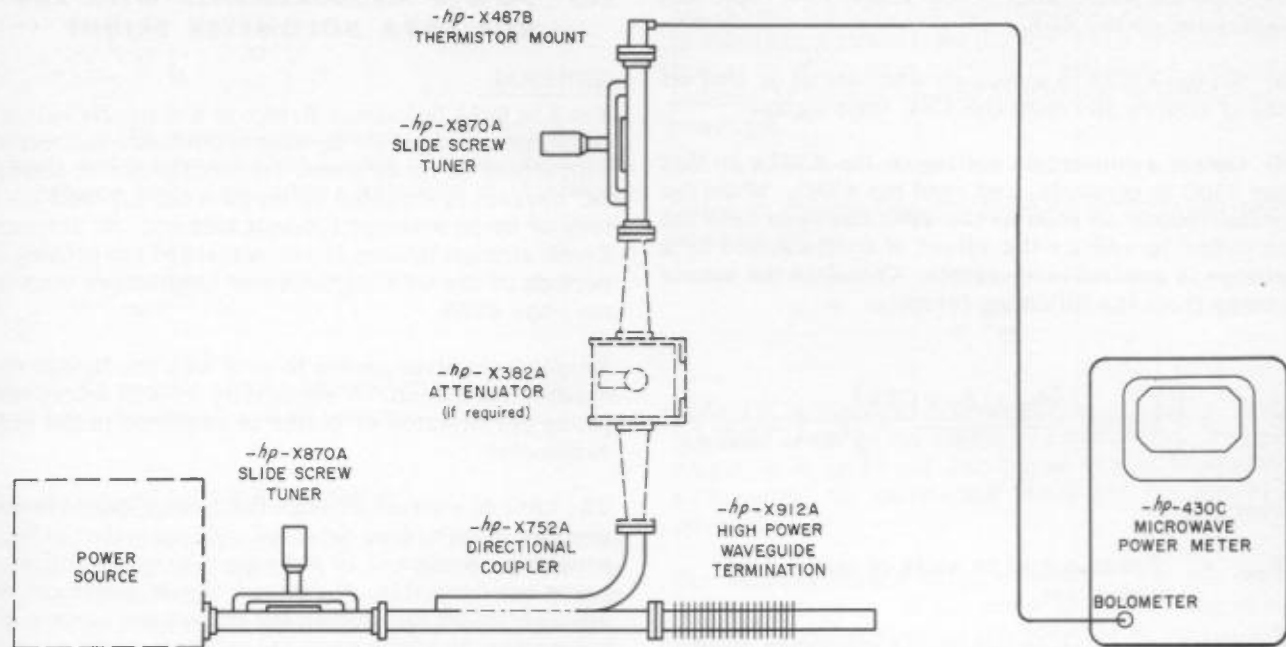

Figure 5-5. Extended Power Range

warm up for 5 minutes. Allow one hour if making power measurements on the 0.1-mw range, in order to achieve the highest accuracy.

4) Set the BIAS CURRENT switch to the first step of the 10-16 MA position.

5) Rotate the ZERO SET controls clockwise. If the pointer goes off scale at the high end or moves to a position on scale, zero-set the meter with the ZERO SET control.

If the pointer rests off scale at the low end, return the ZERO SET controls to the full counterclockwise position. Increase the BIAS CURRENT switch setting one step at a time and attempt to zero the meter. Always return the ZERO SET controls to the full counterclockwise position (minimum bias) before advancing the BIAS CURRENT switch to the next higher position. Do not exceed the setting which corresponds to the maximum current for the bolometer in use.

PROCEDURE (0.1 to 10 mw)

- 1) Apply rf power to the Thermistor Mount.
- 2) Tune the X870A Slide Screw Tuner for maximum indication on the 430C.

3) Shut off the rf power from the instrument under test and zero the 430C once again.

4) Apply rf power and read the 430C. Make the measurement as soon as the 430C has been zero set, to minimize the effect of the drift caused by a change in ambient temperature.

5) When the measurement is completed, shut off the rf power, turn the 430C ZERO SET controls counterclockwise, and set the BIAS CURRENT switch in the OFF position, before disconnecting the Thermistor Mount.

PROCEDURE (Above 10 mw)

- 1) Set the X382A Variable Attenuator (if used) to maximum.
- 2) Apply rf power.
- 3) Carefully decrease the attenuation of the X382A until an up-scale reading is obtained on the 430C.

CAUTION

Decreasing the attenuator too much can damage the thermistor.

- 4) Tune the X870A Slide Screw Tuner for a maximum indication on the 430C.
- 5) Set the X382A to maximum attenuation, or shut off the rf source and zero the 430C once again.
- 6) Obtain a convenient setting on the X382A so that the 430C is on scale, and read the 430C. Make the measurement as soon as the 430C has been zero set in order to reduce the effect of drift caused by a change in ambient temperature. Calculate the source power from the following formula:

$$P_{TI} = \left[\text{Antilog} \frac{(A_R + A_I + CF)}{10} \right] P_M \left(\frac{1}{1000} \right)$$

where

- P_{TI} = Power output in watts of instrument under test.
- A_R = Attenuation reading of the X382A in db.
- A_I = Attenuation of the X382A in db at 0-db reading.
- CF = Coupling Factor of the X752.
- P_M = Reading of the 430C in milliwatts.

Example:

$$A_R = 28 \text{ db}$$

$$A_I = 0.5 \text{ db}$$

$$CF = 3.2 \text{ db}$$

$$P_M = 8 \text{ mw}$$

$$\begin{aligned} P_{TI} &= \left[\text{Antilog} \frac{(28 + 0.5 + 3.2)}{10} \right] (8) \left(\frac{1}{1000} \right) \\ &= \frac{(1480) (8)}{1000} \\ &= 11.8 \text{ watts} \end{aligned}$$

- 7) When the measurements are completed, shut off the rf power, turn the 430C ZERO SET controls counterclockwise, and set the BIAS CURRENT switch in the OFF position, before disconnecting the Thermistor Mount.

5-3 POWER MEASUREMENTS WITH THE K04 999A BOLOMETER BRIDGE

GENERAL

The K04 999A Bolometer Bridge is a manually balanced bridge arranged for dc-bias and balance indication, with either dc or ac power substituted for rf power. DC current is supplied by an internal 6.7-volt battery or by an external 6.0-volt battery. An external 6-volt storage battery is recommended for prolonged periods of use with high-current bolometers such as the -hp- 477B.

An external galvanometer is used with the Bridge for balance indication. A sensitivity of 0.25 microamperes per division or better is required in the galvanometer.

The total dc current through the Bridge can be measured by means of an external milliammeter of high accuracy. Ranges of 10 and either 30 or 50 milliamperes are desirable. If desired, the dc power can be determined by measuring the dc voltage across the bolometer, in which case the milliammeter terminals can be shorted with a switch. The dc voltmeter must have an accuracy of $\pm 1/4\%$ and high impedance compared to 200 ohms. Fluke or KinTel differential voltmeters are suitable for this purpose.

The dc power is varied by Coarse and Fine panel controls. A control for varying the galvanometer sensitivity is also provided.

Audio power is supplied from an external oscillator capable of supplying up to 15 volts at low distortion from 10 kc to 40 kc. Audio voltage is measured by means of an external audio voltmeter of high accuracy.

The bolometer can be operated at either 100 or 200 ohms, selected by means of a panel switch.

The following equipment is recommended for use with the Bridge:

Milliammeter (Sensitive Research, Model CILENT or CILDEN)

Galvanometer (Leeds and Northrup, Model 2320A)

Oscillator (-hp- Model 200AB)

Voltmeter (-hp- Model 400H)

Measurement by DC Substitution

This method is recommended where the rf power is a large fraction of the total power required to bring the bolometer to its operating resistance. The rf

power is calculated from one of the following formulas:

$$P_{rf} = \left(\frac{I_1}{2}\right)^2 R - \left(\frac{I_2}{2}\right)^2 R ,$$

where R is the operating resistance (100 or 200 ohms), and I_1 and I_2 are the total Bridge currents required for balance before and after application of rf power.

$$P_{rf} = \frac{E_1^2 - E_2^2}{R} ,$$

where E_1 and E_2 are dc bolometer voltages before and after application of rf power.

Measurement by AF Substitution

This method is recommended where the rf power is small compared to the total power required to bring the bolometer to its operating resistance. The Bridge is balanced with the rf power applied to the bolometer. The rf power is then turned off and af power applied. The Bridge is rebalanced by adjusting the af power level. The substitution power is then equal to E_{af}^2/R . The dc supply must be stable and the bolometer mount must be protected from changes in ambient temperature. The normal audio frequency for thermistors and Sperry barretters is 10 kc. For barretters with smaller time constants, such as the PRD 4-milliwatt barretters, the frequency must be at least 30 kc.

ACCURACY

The accuracy of a measurement with the K04 999A Bolometer Bridge depends upon the system mismatch loss, rf loss, substitution error, and error in measurement of substituted power as discussed in Para-

graph 5-1. This error depends upon the accuracy of indicators, the total bolometer power, and the amount of substituted power. As the accuracy of most indicators is given as a percent of full scale, the percentage of possible error increases on down-scale readings.

Using dc substitution, the possible error in the measurement is:

$$\alpha = 2\epsilon \left(\frac{2P_t}{P_{rf}} - 1 \right)$$

where P_t is the total bolometer power and ϵ is the possible error in the reading of the meter. For example, if P_t is 15 mw and P_{rf} is 10 mw, typical for a barretter, the instrument error 2ϵ (in power) is doubled.

For measurements using af substitution, the error is 2ϵ where ϵ is the error in the reading of the meter. A graph showing the possible error for various bolometers, and using the suggested indicating instruments, appears in Figure 5-6.

MEASUREMENT SETUP

The following paragraphs describe power measurements with the manually-balanced K04 999A Bolometer Bridge and the PRD 627 A Bolometer Mount, -hp- 477B, and X487B Thermistor Mounts. In coax systems the 627A Bolometer Mount is used below 5 milliwatts, and the 477B Thermistor Mount up to 25 milliwatts. The X487B Thermistor Mount can be used for powers up to 12 milliwatts. Audio or dc power can be substituted for rf power. The choice depends upon the operating resistance of the bolometer mount and upon the power level.

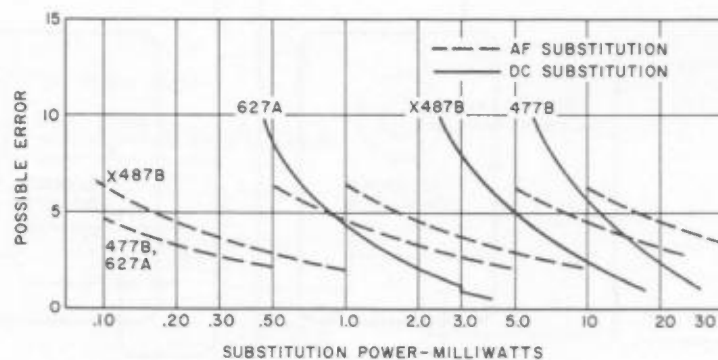

Figure 5-6. Measurement Accuracy of Substituted Power

AF-SUBSTITUTION PROCEDURE

- 1) K04 999A Bolometer Bridge Control Settings:
 GALV LAMP-DC switch to OFF-OFF.
 AF switch to OFF.
 MA switch to right, if milliammeter is used.
 100 OHM-200 OHM switch to 200 OHM for the 627A and 477B; to 100 OHM for the X487B.
 Int-Ext switch in rear to Ext, if external battery is used.
 AF LEVEL control to mid position.
 DC COARSE and FINE controls fully counterclockwise.
 GALV SENS control fully counterclockwise.
- 2) Connect the equipment as shown in Figure 5-7.
 Do not apply rf power at this time.

NOTE

The milliammeter is not required in this measurement. Its use greatly facilitates the balance adjustment, however, and is particularly recommended when using the 627A Bolometer Mount. The 627A is easily burned out by too much power.

- 3) Set the 200AB Oscillator to 40 kc. If the rf power is known approximately, set the 200AB AMPLITUDE control to give approximately the corresponding voltage as read on the 400H Voltmeter. Otherwise, reduce to a low value.
- 4) Set the Milliammeter to SHORT.

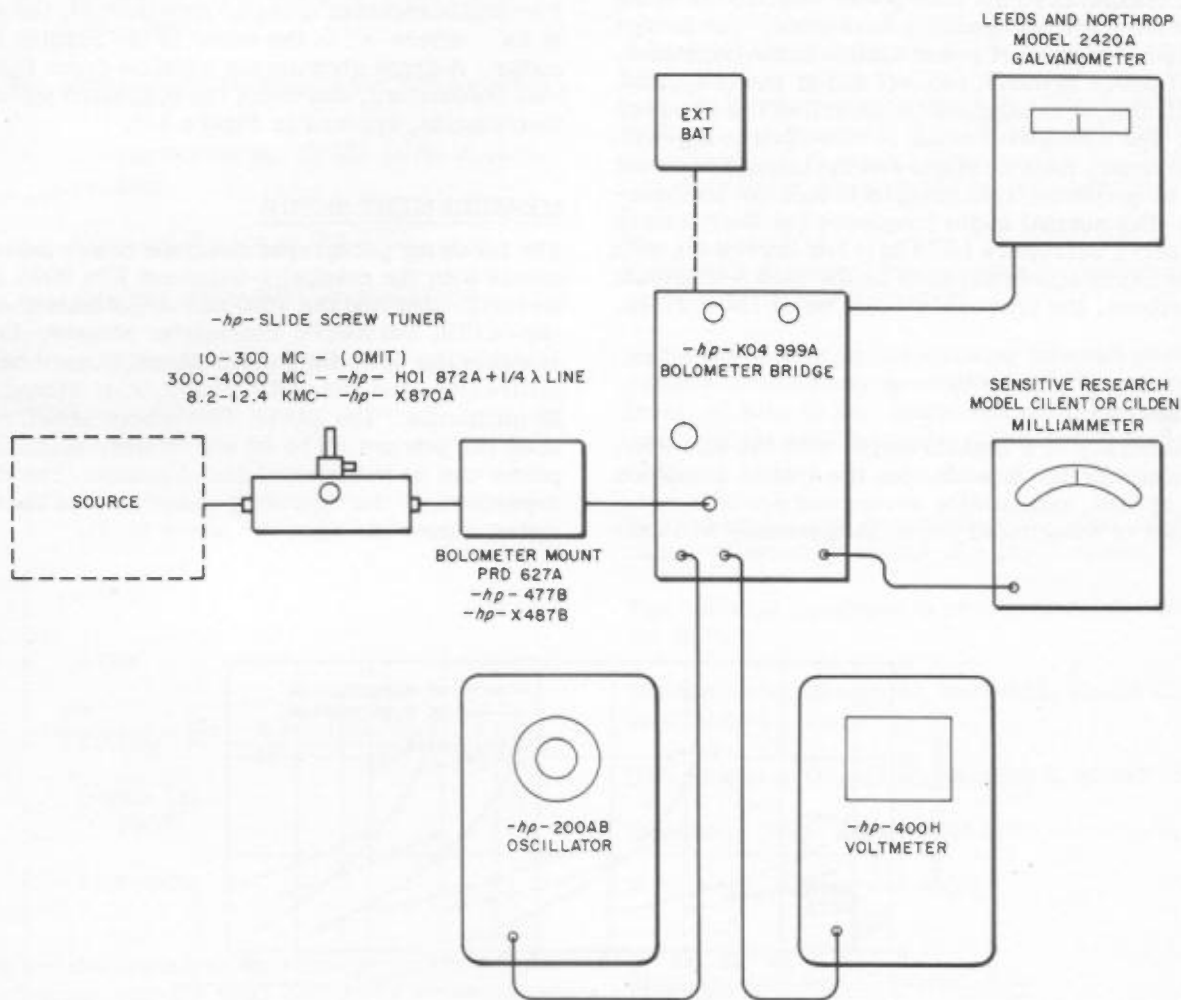

Figure 5-7. Power Measurement Using AF Substitution

5) Set the Bolometer Bridge GALV LAMP-DC switch to the ON-OFF position and zero the Galvanometer mechanically.

6) Apply the rf power to the bolometer.

7) Set the Bolometer Bridge GALV LAMP-DC switch to ON-ON. Set the Milliammeter to the appropriate range, and adjust the COARSE control for a reading of about 7-1/2 milliamperes if the bolometer is a 627A, 20 milliamperes if it is a 477B or a X487B.

8) Adjust the Bolometer Bridge GALV SENS control to obtain a deflection on the Galvanometer. Carefully adjust the COARSE and FINE controls to get an approximate balance as indicated on the Galvanometer. Note the direction of deflection for increasing the dc power when near balance. (Direction of deflection of very low currents will always be away from balance, because the sensitivity of the circuit is increased as the current is increased, even though more current is required for balance.)

9) Adjust the Slide Screw Tuner to obtain a maximum deflection, maintaining the Galvanometer indication near zero by decreasing the dc.

10) Increase the Galvanometer sensitivity as required. For a given deflection, the setting of the GALV SENS control will be further clockwise for the 627A Bolometer Mount than for the 477B, because of the lower current requirement of the 627A.

11) After balance is achieved with the Slide Screw Tuner adjusted for maximum rf power, turn the GALV SENS fully counterclockwise, and turn the rf power off.

12) Set the Bolometer Bridge AF switch to ON and adjust the AF LEVEL control to restore balance, increasing the galvanometer sensitivity as required.

NOTE

Steps 12 and 13 must be performed as rapidly as possible, to minimize the effect of temperature drift of the bolometer.

13) Note the reading of the 400H Voltmeter and calculate the power. $P = \frac{E^2}{R}$

<u>Instrument</u>	<u>R (ohms)</u>
627A	200
477B	200
X487B	100

DC-SUBSTITUTION PROCEDURE

- 1) K04 999A Bolometer Bridge Control Settings:
 GALV LAMP-DC switch to OFF-OFF.
 AF switch to OFF.
 MA switch to right.
 100 OHM-200 OHM switch to 200 OHM for the 627A and 477B; to 100 OHM for the 487B.
 Int-Ext switch in rear to Ext, if external battery is used.
 DC COARSE and FINE controls fully counterclockwise.
 GALV SENS controls fully counterclockwise.
- 2) Connect the equipment as shown in Figure 5-8. Do not apply rf power at this time.

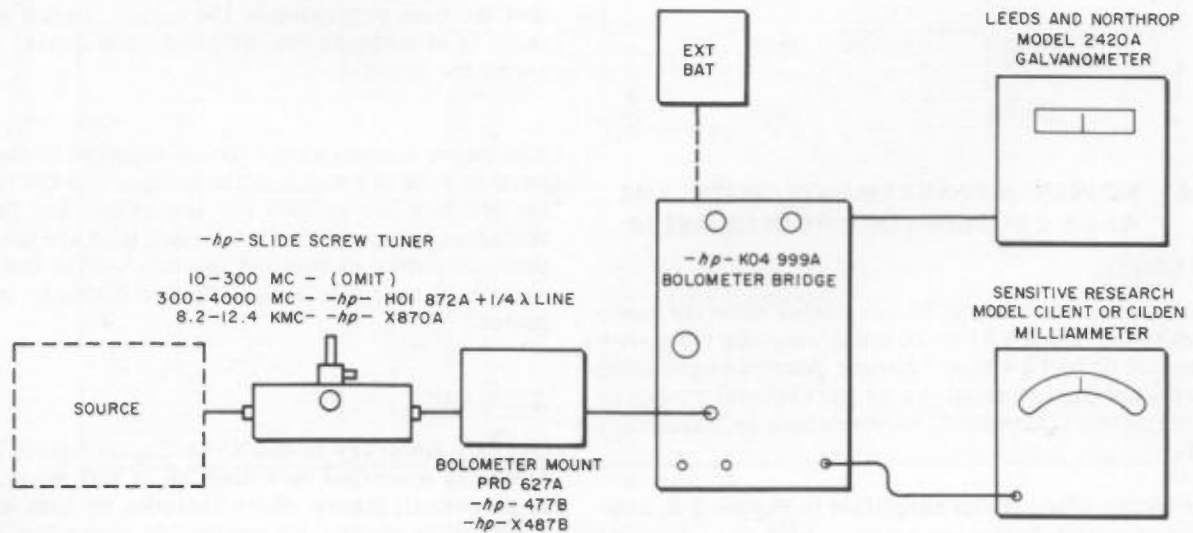

Figure 5-8. Power Measurement Using DC Substitution

- 3) Set the Milliammeter to SHORT.
- 4) Set the Bolometer Bridge GALV LAMP-DC switch to ON-OFF position and zero the Galvanometer mechanically.
- 5) Apply the rf power to the bolometer.
- 6) Set the Bolometer Bridge GALV LAMP-DC switch to ON-ON. Set the Milliammeter to the appropriate range, and adjust the COARSE control for a reading of about 4.5 milliamperes if the bolometer is a 627A, 14 milliamperes if it is a 477B or X487B.
- 7) Adjust the Bolometer Bridge GALV SENS control to get a deflection on the Galvanometer. Carefully adjust the COARSE and FINE controls to get an approximate balance as indicated on the Galvanometer. Note the direction of deflection for increasing dc power when near balance. Adjust the Slide Screw Tuner to obtain maximum deflection, maintaining the Galvanometer indication near zero by decreasing the dc.
- 8) Increase the Galvanometer sensitivity as required and adjust the FINE control for balance. Read the Milliammeter and record the reading as I_2 .
- 9) Turn the GALV SENS control fully counterclockwise and turn the rf power off.
- 10) Increase the dc to reestablish balance, increasing the Galvanometer sensitivity again as required.
- 11) Read the Milliammeter and record reading as I_1 .
- 12) Calculate the power.

$$P = \left[\left(\frac{I_1}{2} \right)^2 - \left(\frac{I_2}{2} \right)^2 \right] R$$

Instrument	R (ohms)
627A	200
477B	200
X487B	100

5-4 POWER MEASUREMENTS WITH THE 434A CALORIMETRIC POWER METER

GENERAL

The 434A Calorimetric Power Meter directly measures power from 0.01 to 10 watts over the frequency range of dc to 12.4 kmc. Larger powers can be measured by using attenuators or directional couplers ahead of the instrument, as described in Paragraph 5-1.

The Model 434A, shown simplified in Figure 5-9, consists of a self-balancing bridge which has identical temperature-sensitive resistors (gauges) in two legs, an indicating meter, and two load resistors, one for

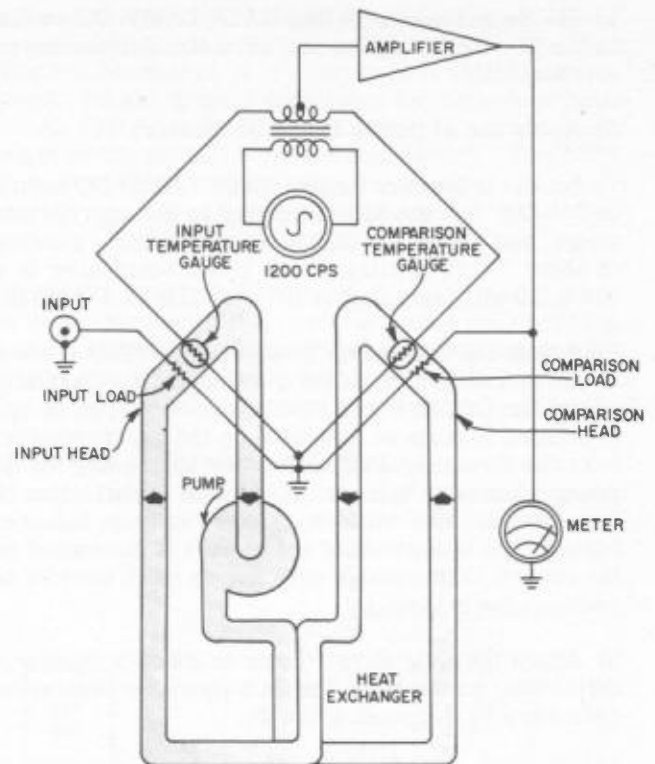

Figure 5-9. Simplified Diagram of the -hp- 434A

the unknown input power and one for the comparison power. The input load resistor and one gauge are in close thermal proximity, so that heat generated in the input load resistor heats the gauge and unbalances the bridge. The unbalance signal is amplified and applied to the comparison load resistor, which is in close thermal proximity to the other gauge, so that the heat generated in the comparison load resistor is transferred to its gauge and nearly rebalances the bridge.

The meter measures the power supplied to the comparison load to rebalance the bridge. As the characteristics of the gauges are the same, and the heat transfer characteristics from each load are the same, thus the power dissipated in each load is the same, and the meter can be calibrated directly in input power.

ACCURACY

Overall accuracy of the 434A Calorimetric Power Meter is specified as within 5% of full scale. This is an overall figure which includes rf loss and dc-calibration error. By evaluating these losses, the accuracy can be increased to approximately the values shown in Table 5-3.

TABLE 5-3. ESTIMATED ACCURACY OF THE 434A

FREQUENCY	ESTIMATED ATTAINABLE ACCURACY	
	0.01, 0.03 Ranges	0.1, 0.3, 1, 3, 10 Ranges
dc	2%	1/2%
0-1 kmc	3%	1%
1-4 kmc	4%	2%
4-10 kmc	5%	3%
10-12.4 kmc	5%	4%

Greater accuracy can be obtained by the following method:

- 1) Calibrate the 434A Power Meter with an accurately known dc power of the appropriate level by adjusting resistor R79 in the Meter Circuit for an exact reading at the desired power level. See the following paragraphs for general calibration procedure. With adequate dc instrumentation the dc error can be reduced to about $\pm 1/2\%$.
- 2) Eliminate mismatch loss with a good low-loss tuner. For greatest accuracy, the loss in the tuner must be evaluated. Tuner loss equals percent loss times meter reading.
- 3) Find the rf loss from Figure 5-10 (meter reading in watts times percent loss). Figure 5-10 gives

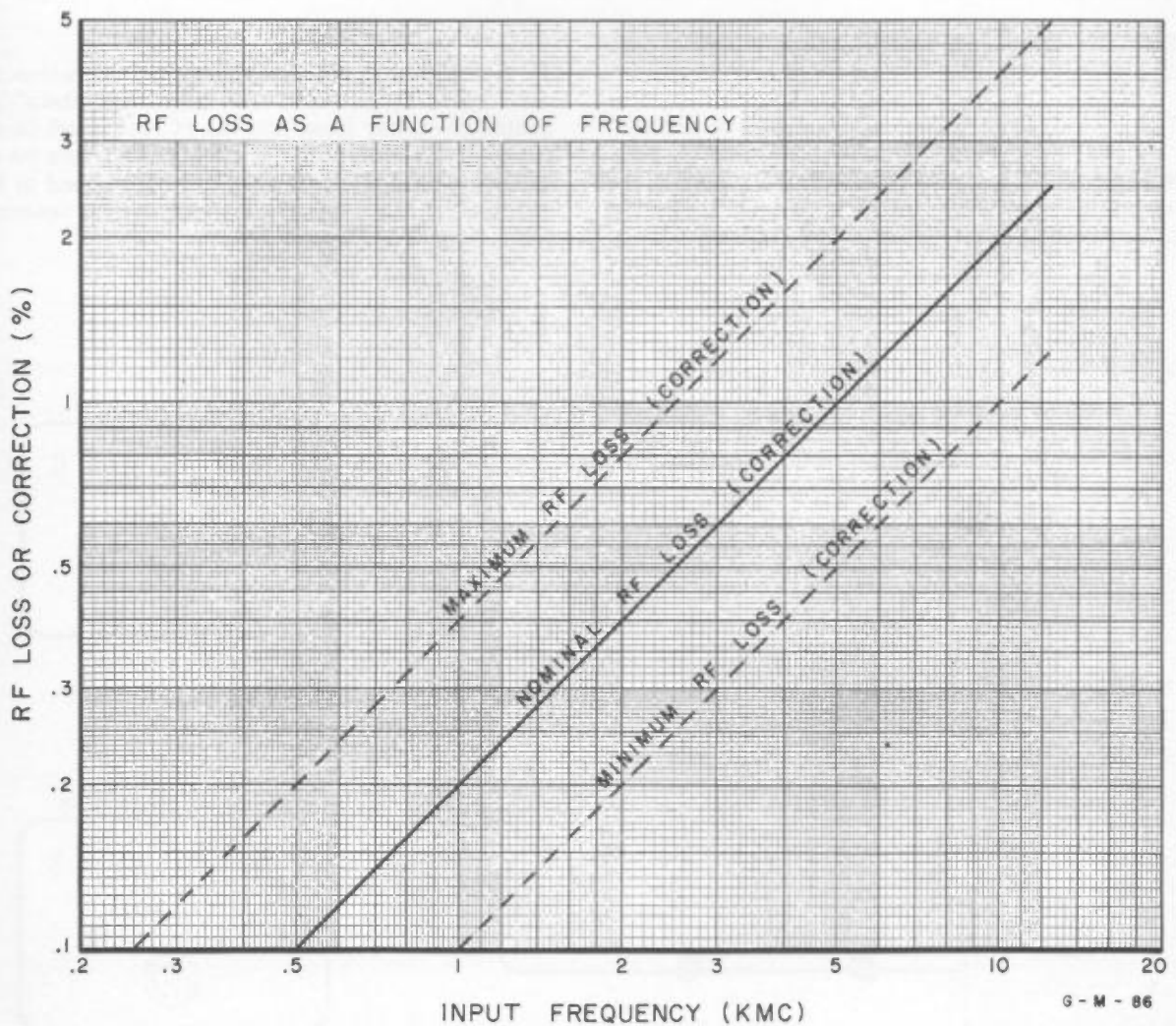

Figure 5-10. RF Loss Showing Probable Limits of Error

a nominal correction to be applied, with the probable limits of error.

4) Add the tuner loss and the rf loss to the meter reading.

CALIBRATION PROCEDURE (For Greatest Accuracy)

1) Connect the 434A Power Meter and K01 434A Test Set to 115V ac power. Turn on the equipment and allow it to warm up for 10 minutes.

2) Set the 434A Power Meter RANGE switch to the appropriate range for the rf power to be measured. Also set the K01 434A for the proper output power.

3) Connect the K01 434A Test Set POWER OUTPUT to the 434A INPUT. Turn the power output switch off and zero the % ERROR meter with the ZERO ADJ. control.

4) Zero-set the 434A meter with the ZERO SET control.

5) Turn the K01 434A power output switch to ON.

6) Read the 434A and note the error. If desired, the 434A can be exactly calibrated by adjusting the VM CAL. control (R79) for the correct reading.

POWER MEASUREMENT PROCEDURE

1) Connect the equipment as shown in Figures 5-11 and 5-12. Connect the Tuner directly to the Power Meter. Do not apply rf power now.

2) Turn on the equipment and allow it to warm up for 10 to 15 minutes.

3) Set the 434A RANGE switch to the appropriate range for the power to be measured, and zero-set the meter.

4) Apply the rf power and adjust the Tuner for maximum reading.

5) Switch the rf power off and zero-set the 434A meter exactly.

6) Apply rf power and read the meter.

7) For greatest accuracy, the dc calibration error determined from the "Calibration Procedure" paragraph, the tuner loss, and the rf loss must be added to the meter reading. The tuner loss can be measured with the attenuation system described in Paragraphs 3-2 and 3-3. The rf loss can be determined from Figure 5-10.

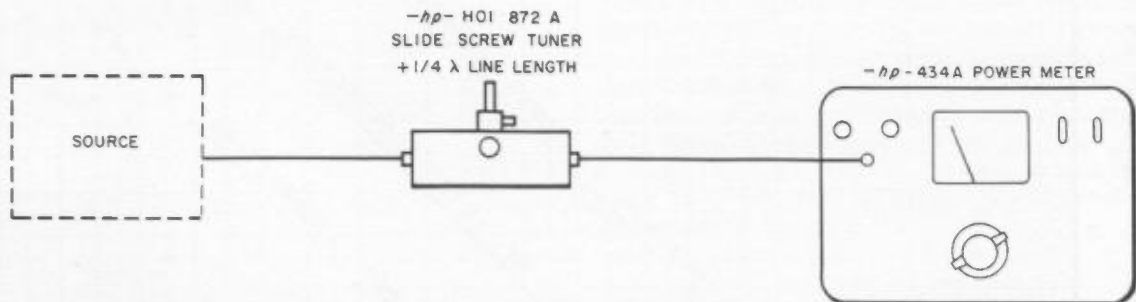

Figure 5-11. Power Measurement in Coaxial Systems (0.01 to 10 watts)

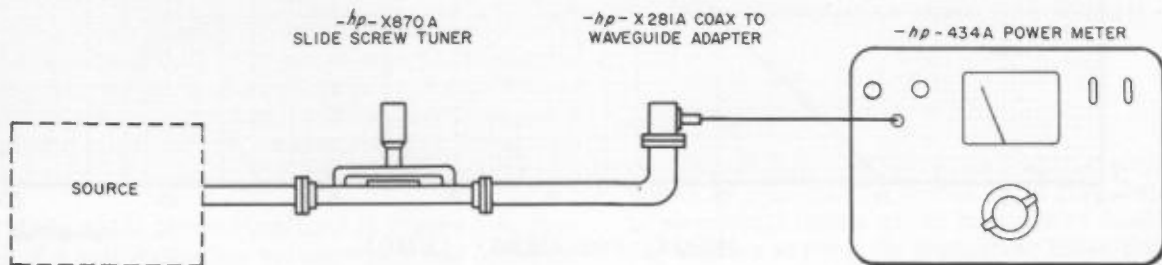

Figure 5-12. Power Measurement in Waveguide Systems (0.01 to 10 watts)

Example:

Frequency: 10 kmc

434A Meter Reading: 9 watts

Possible Errors (in per cent)

DC Calibration Error:	-1% ($\pm 1/2\%$)
Tuner Loss (0.05 db):	-4% ($\pm 1\%$)
RF Loss (from Figure 5-10):	$\frac{-2\% (+1\%, -2\%)$ $-7\% (+2-1/2\%,$ $-3-1/2\%)$

Total Power Loss = $-7\% \times 9 \text{ watts} = -0.63 \text{ watts}$

Corrected Power = 9 watts + 0.63 watts
 = 9.63 watts ($+2-1/2\%, -3-1/2\%$)
 = 9.63 watts ($\pm 3\%$)

5-5 REFERENCES

E. L. Ginzton "Microwave Measurements" McGraw-Hill, New York, 1957.

B. P. Hand, Power Measurements with the 434A Power Meter, "hp- Journal," vol. 9, No. 12.

G. U. Sorger, The Thermal Time Constant of a Bolometer, "Engineering Notes," No. 3, Weinschel Engineering Co., Inc.

Wind and Rapaport "Handbook of Microwave Measurements" (2nd ed.), Polytechnic Institute of Brooklyn, New York, 1955.

ADDENDA

BOLOMETER MOUNT EFFICIENCY MEASUREMENT

B. P. Hand
Hewlett-Packard Company
Palo Alto, California

- References: 1) "Determination of Efficiency of Microwave Bolometer Mounts from Impedance Data," David M. Kerns, Jrnl. of Res. NBS, June 1949, p. 579.
- 2) "An Improved Method of Measuring Efficiencies of UHF and Microwave Bolometer Mounts," R. W. Beatty and Frank Reggia, Jrnl. of Res. NBS, June 1955, p. 321.

These references discuss the theoretical aspects of bolometer-mount efficiency measurement by the impedance method. This note is intended to discuss the actual techniques used in making the impedance measurement in X-band waveguide. The circuit is shown in Figure 1.

The method requires the measurement of input reflection coefficient for three values of bolometer resistance. To simplify calculations, the reflection is made zero for one value of resistance by tuning the mount. A reference level is set on the 415B with a short on the line, and the reflection is read on the 415B for each of the extreme values of resistance. The relative phase of the two reflection coefficients may be determined with the X885A and X382A in the auxiliary arm.

Possible sources of error which must be accounted for are :

- (1) The imperfection of the short used to set reference level. It must be calibrated for its own reflection coefficient, which will be in the order of 1% to 2% less than 100%. The reference level setting must be corrected for this. A VSWR measurement may be made using the X382A to determine the reflection of the short.
- (2) The re-reflection between detector mount and short when setting the reference level. A signal reflected from the detector will re-reflect from the short and add in random phase at the detector. Thus, an adjustable short must be used, and the detector must be tuned to give very small variation in output as the position of the short is varied. The correct reference level is the average of the maximum and minimum readings. When the output is read on a db scale, the average db reading does not correspond to average voltage. The necessary setting for average voltage is given in Figure 2.

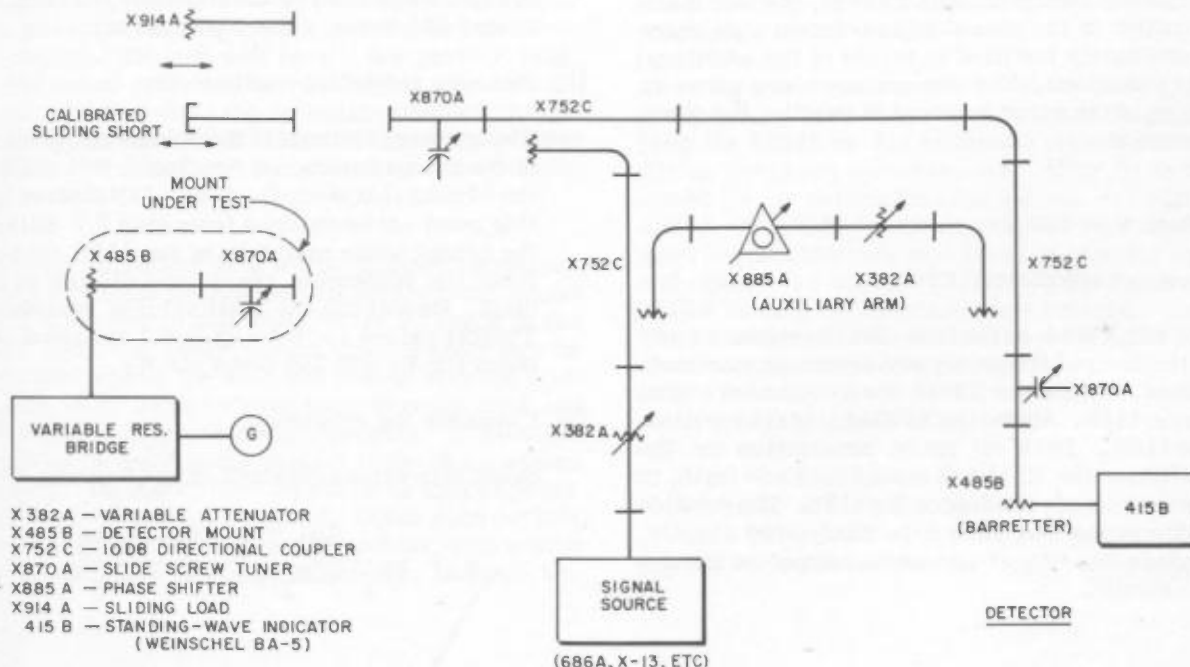

Figure 1 - Circuit Diagram

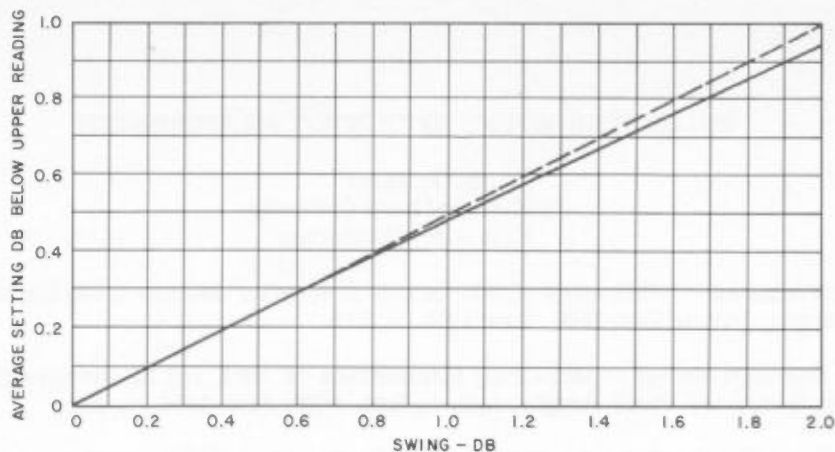

Figure 2 - DB Setting for Average Voltage

- (3) The finite directivity of the coupler used to introduce the signal into the system. The X914A and adjacent X870A are used to cancel out the leakage signal.
- (4) The calibration of the 415B. This may be calibrated at 1 kc using a ratio transformer. Typical readings on the 415B will be at full scale on the 30 and 50 ranges, corresponding to a reflection coefficient of -20 db or 0.1. To obtain greatest resolution the expanded scale should be used.
- (5) The accuracy of the resistance measurements. These should be determined to 0.1% or better. A bridge made up of G. R. 0.05% resistors and decades is suitable. A circuit diagram is given Figure 3.

With high-efficiency mounts (>95%), the additional complication of the phase-measurement equipment is not ordinarily justified in terms of the additional accuracy obtained. The second reference gives an evaluation of the error incurred in omitting the phase measurement.

Procedure is as follows:

- (1) Tune out the directivity signal.

Put the X914A on the line. Set the signal source to the desired frequency and adjust for maximum output. Adjust the X914A for a maximum signal on the 415B. Adjust the X870A to obtain a null on the 415B. Back off probe penetration on the X870A, as the X914A is moved back and forth, to obtain a steady reading on the 415B. The position of the probe may have to be readjusted slightly. Reduce the signal generator output to about 2 milliwatts.

- (2) Set the reference level.

Put the sliding short on the line. Adjust the X870A on the detector for a minimum of variation in the 415B reading, preferably less than 1.5 db. Set the short to give the correct average reading as determined from the curve. Set the level to give a reading at full scale on the 20 range. Set the 415B METER SCALE switch to EXPAND. Set the RANGE switch to 30. Adjust the GAIN control to give a full-scale reading.

- (3) Tune the mount.

Put the mount and its tuner on the line. (The combination together must be regarded as the mount being calibrated.) Adjust the tuner for a null on the 415B while the variable-resistance bridge is balanced in the 200-ohm position. R_2 is now 200 ohms, while ρ_2 is zero.

- (4) Measure reflection coefficients.

Change the resistance of the bolometer by means of the bridge to obtain a reading at full scale on the 50 range (expanded). (The GAIN control setting must not be changed from step 2.) Balance the bridge while maintaining the 415B reading. Read the bolometer resistance off the bridge dials. Repeat for the other value of resistance. Typical values for $\rho_1 = \rho_3 = 0.1$ are about 160 ohms for R_1 and 245 ohms for R_3 .

- (5) Calculate the efficiency.

Substitute values obtained in the formula

$$\eta = \frac{2R_2 (R_3 - R_1) \rho_1 \rho_3}{(R_3 - R_2)(R_2 - R_1)(\rho_1 + \rho_3)} *$$



OPERATING NOTES

HEWLETT-PACKARD COMPANY • 1501 PAGE MILL ROAD • PALO ALTO, CALIFORNIA, U.S.A.
CABLE "HEWPACK" TELEPHONE DAVENPORT 6-7000

MODEL K04 999C LINE LENGTH SET

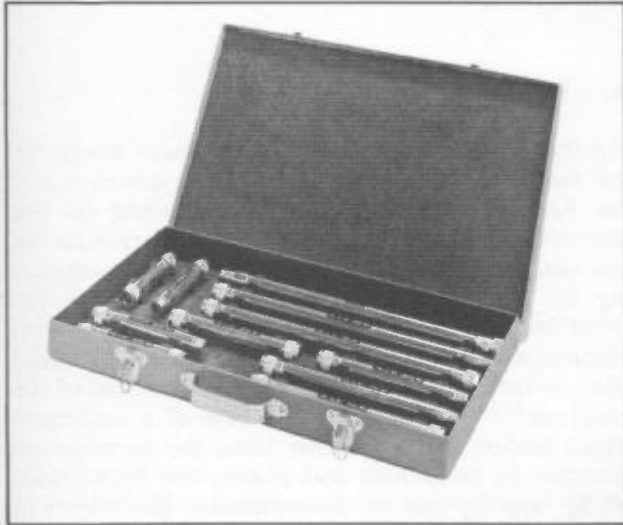

The K04 999C Line Length Set provides sections of precision rigid line for use in the measurement of the directivity of coaxial directional couplers. The Line Length Set includes a basic length, which is a short section of rigid line, and a set of precision sections which are a quarter wavelength longer than the basic length at 350 mc, 750 mc, 1500 mc, and 3 kmc, respectively. Each section is supplied as a male-to-female length and as a male-to-male length. The Set also includes a spacer which when used with the Model 872A Coaxial Slide-Screw Tuner will extend its tuning range down to 215 mc.

The technique for using the Line Length Set will be more meaningful if there is some understanding of the nature of directivity and the error signals which determine directivity. Therefore both subjects are briefly discussed (paragraphs 1, 2) before the Line Length Set is discussed.

1. DIRECTIVITY

A directional coupler consists of a main arm or line with two ports, and an auxiliary arm or line with one port and a built-in matching termination. Waves traveling in one direction in the main arm ideally excite waves traveling in one direction only in the auxiliary arm.

In coaxial directional couplers there is a section of the auxiliary line with the center conductor in close proximity to the center conductor of the main line. In this region the two lines are coupled

both capacitively and inductively. These two types of coupling are related in such a way that a wave traveling in one direction only in the main line gives rise primarily to a wave traveling in the opposite direction in the auxiliary line. A wave of much smaller amplitude (arising from unavoidable imperfections in the coupling mechanism) is excited in the auxiliary line in the same direction as the incident wave in the main line; this wave flows into the matching termination and is virtually absorbed. Figure 1 shows the general case where there are waves traveling in both directions in the main line of a coupler. E_1 is the amplitude of the wave incident on the coupler from the left, and E_2 is that of the wave incident on the coupler from the right. The amplitude E_C of the coupled wave appearing at the auxiliary-line output is a linear combination of E_2 and E_1 :

$$E_C = \alpha E_2 + \beta E_1$$

If the coupler were perfect we would have $\beta = 0$.

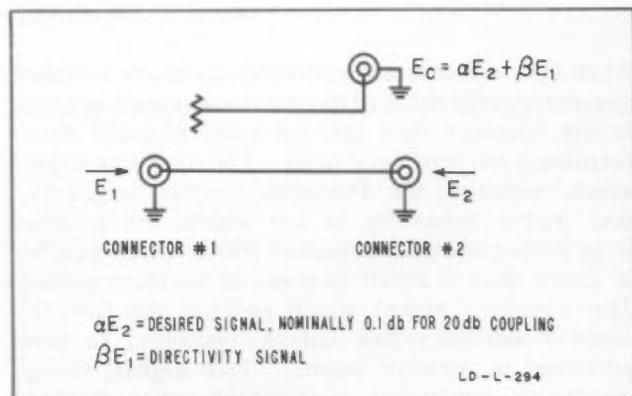

Figure 1. Components of Signal Appearing at Auxiliary-Line Output of Coaxial Directional Coupler

However, because of imperfections in the coupling mechanism, imperfect match of the termination of the auxiliary line, and the reflection from connector #2, we have in general that β is not zero. The directivity, D , in decibels of a coupler is defined as follows:

$$D = 20 \log \left/ \frac{\alpha}{\beta} \right/$$

2. ERROR SIGNALS IN DIRECTIONAL COUPLERS

Coaxial directional couplers of the 764-767 series are dual couplers. Each assembly has two auxiliary lines and a common main line. Which is the forward coupler and which the reverse depends on the direction of incident power flow in the main line. There are four ports on the assembly. These are identified in Figure 2 with respect to a wave flowing to the right in the main line.

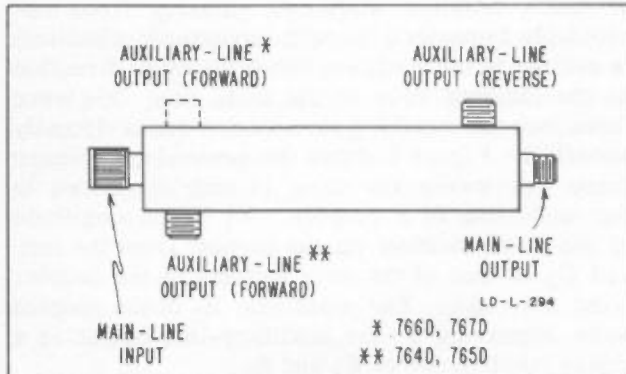

Figure 2. Dual Coaxial Directional Coupler, Identification of Ports with Respect to a Wave Flowing to the Right in the Main Line

When both incident and reflected waves are sampled simultaneously most of the spurious signals present in the couplers flow into the matched loads which terminate the auxiliary lines. The spurious signal which reaches the Forward coupler auxiliary-line output generally is not significant because it is proportional to reflected power which seldom is more than a small percent of incident power. The spurious signal which reaches the Reverse coupler auxiliary-line output, however, is proportional to incident power. This signal, though small, is significant, particularly when the load reflection being measured is small. Shown on Figure 3 as S_1 , this signal is a component of βE_1 (see Figure 1).

In addition to signal S_1 , which is due to imperfection in the coupling mechanism, there are discontinuities in the region of the output connector on the main line. These reflect a small signal, part of which (S_2) (also a component of βE_1 , Figure 1) will reach the Reverse terminal. These small signals (S_1 and S_2), that account for lack of perfect directivity in the couplers, are indicated

in Figure 3 for a wave flowing to the right in the main line. The condition that exists at the Reverse terminal is indicated vectorially in Figure 4A. S_1 and S_2 add in some unknown phase to give a resultant signal, S_{dir} , called the directivity signal.

3. THEORY OF OPERATION

Ideally, if a perfect termination were available for the main-line output, the signal measured at the Reverse auxiliary-line output would be the directivity signal. But perfect coaxial terminations are not available. The problem, then, in measuring the directivity of coaxial directional couplers, is to measure the vector sum of S_1 and S_2 exclusive of any signal reflected to the same terminal from a termination placed on the output end of the couplers. With the development of a technique which makes the reflection from the termination variable in magnitude and phase, the vector sum of S_1 and S_2 can be determined. The theory of this technique is discussed below, and the procedure in paragraph 4.

The setup for measuring directivity in a dual directional coupler when power is to flow to the right in the main line is indicated in Figure 5. The coupler is fed from a source of modulated rf power. A K04 999C section is inserted between the directional coupler and the tuner, and the tuner is terminated by a load. The signals appearing at the output of the Reverse coupler are detected and measured.

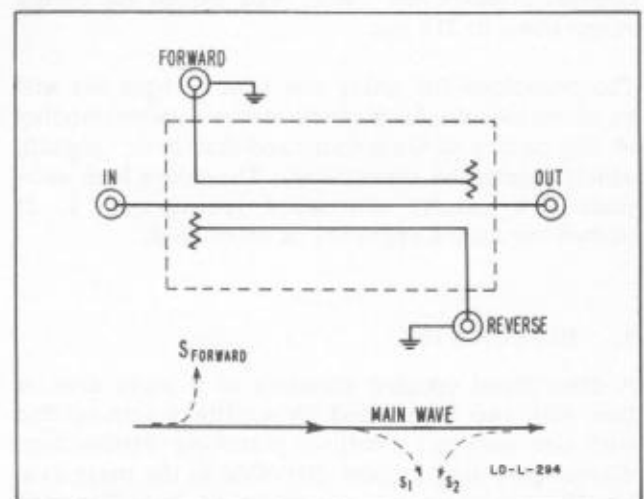

Figure 3. Schematic Diagram of Dual Directional Coupler

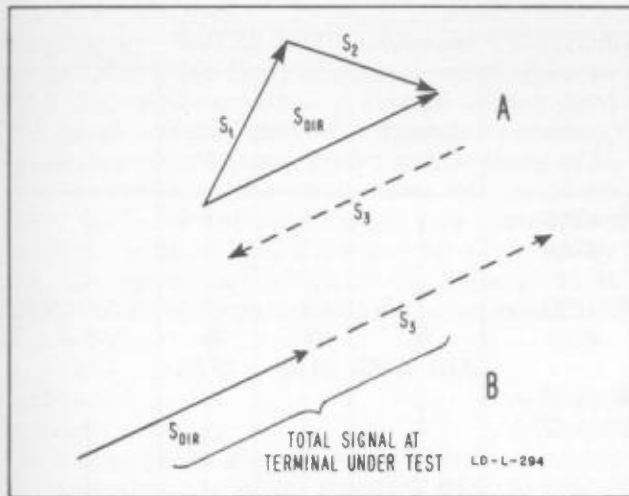

Figure 4. Vector Diagram of Error Signals which Account for Directivity, and Compensating Signal S_3 Set Up when Measuring Directivity

Briefly the measurement technique is this: A reference level (S_{ref}) is set. Then, with basic line length L_1 in the setup, a signal (S_3) is set up which is equal to and 180° out of phase with the vector sum of S_1 and S_2 (S_{dir}). (See Figure 4A.) Then L_1 is removed and another line section is inserted which is one-quarter wavelength longer than L_1 at the signal frequency. S_3 is thus delayed an additional 180° so that it is now in phase with S_{dir}

(see Figure 4B). Under this condition the signal at the auxiliary-line output is known to have twice the magnitude of S_{dir} , and directivity can be determined from the values of S_{ref} and S_{dir} .

Signal S_3 is made up of reflections (see Figure 11) from the connectors, from the load, and from the tuner. The tuner is necessary to establish S_3 equal in amplitude and opposite in phase to S_{dir} .

4. OPERATION

The following describes a procedure for measuring directivity in a coaxial directional coupler.

For optimum accuracy, power should be monitored. With a dual directional coupler, power may be monitored at the Forward coupler. With a single directional coupler, a monitor channel can be obtained by inserting an additional coupler in the line, ahead of the coupler under test.

A typical setup for measuring the directivity of a dual directional coupler is indicated in Figure 5.

A. EQUIPMENT REQUIRED

Components of the measurement system are briefly described below. Equipment suitable for use in the various regions of the coaxial range are shown in Table I.

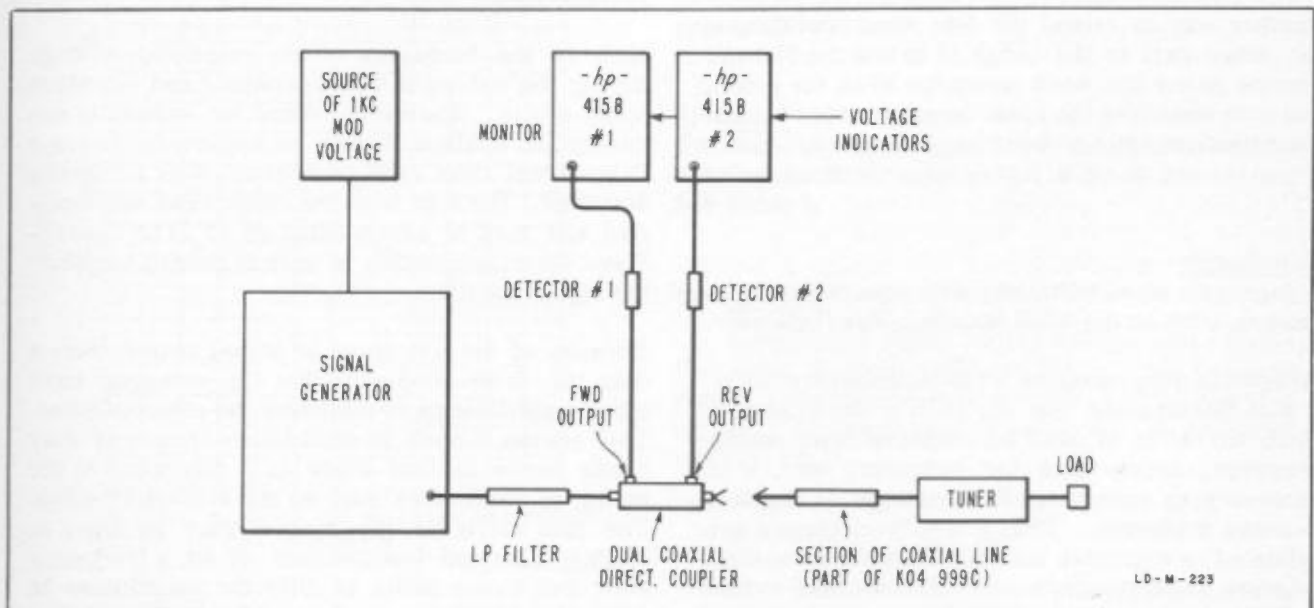

Figure 5. Setup for Measuring Directivity of a Dual Coaxial Directional Coupler

TABLE I. EQUIPMENT SUITABLE FOR DIRECTIVITY MEASUREMENT SETUP

Coupler under Meas	Freq Range (mc)	Sig Gen	Source of Mod Volts	Low Pass Filter	Detector	Line Length Set	Meter	Tuner	Load
Ⓢ 764D	215-450	Ⓢ 608C	---	Ⓢ 360A	Ⓢ 420B or 476A	↑	↑	↑	↑
Ⓢ 765D	450-945	Ⓢ 612A	---	Ⓢ 360B	Ⓢ 420B or 476A	Ⓢ K04 999C	Ⓢ 415B	Ⓢ 872A	Weinschel 535-FN or -MN
Ⓢ 766D	940-1975	Ⓢ 614A	Ⓢ 211A	Ⓢ 360C	Ⓢ 420B or PRD 627A	↓	↓	↓	↓
Ⓢ 767D	1900-4000	Ⓢ 616A	Ⓢ 211A	Ⓢ 360D	Ⓢ 420B or PRD 627A	↓	↓	↓	↓

1) K04 999C Line Length Set -

The Set includes a basic length (L1), sections (L2) which are a quarter wavelength longer than the basic at 350 mc, 750 mc, 1500 mc, and 3 kmc, and a spacer which extends the range of the 872A tuner down to 215 mc. In the range from 215 to 450 mc it may not be possible to adjust the tuner to get a null with the basic length in the line because travel of the 872A carriage is limited. When operating in the 215- to 450-mc range, the spacer may be inserted between the tuner and the termination, thus in effect extending the carriage position into the region on the line necessary to obtain the null.

Another way to extend the line when operating in the lower part of the range is to use the 350-mc section in the line when tuning the 872A for a null, and then installing the basic length in order to shift the reflection 180°.

2) Indicator -

A high-gain tuned voltmeter with square-law calibration, such as the 415B Standing-Wave Indicator.

To specify the procedure for measuring directivity, it will be assumed that the 415B is the indicator. When the 415B is used for relative level measurements, rather than for indicating swr, it is necessary to regard its DB readings as negative to avoid confusion. Thus lower level signals are indicated as a greater number of db. The readings referred to below are the sum of the RANGE switch and DB scale readings (both negative) and the bottom (EXPAND NORMAL -5 DB) switch setting

(0 or +5 db). For example, values of 30, 2 and -5, respectively, would be a relative level of $-30 - 2 + 5 = -27$ db.

For clarity, meter indications and switch settings used in the procedural explanations are stated as negative or positive values. For example, if the RANGE switch is set at 30, it is stated as a RANGE switch setting of -30 db.

3) Source of rf power modulated at 1 kc -

A generator whose output level can be varied is recommended.

Shift in the frequency of the modulation voltage during the course of a measurement can introduce some error. Therefore where the utmost in accuracy is desired it may be necessary to use a 1-kc signal from an Ⓢ counter or other frequency standard. The 1 kc from the counter can be amplified and used to synchronize an Ⓢ 211A Square-Wave Generator which in turn is used to modulate the signal source.

Because of the low level of signal output from a detector, it is necessary that the voltmeter have tuned amplification to minimize the effect of noise. The reason a shift in modulation frequency may cause error is that there is a tolerance in the tuning of voltmeters such as the 415B ($1 \text{ kc} \pm 2\%$). The two 415Bs in the system may be tuned to slightly different frequencies; if so, a frequency shift can cause shifts of different magnitudes in their indications, or even shifts in opposite directions.

4) Detector -

An Φ 420B Wide Band Crystal Detector may be used for measurements over the entire band (215 mc to 4 kmc). However, for greater accuracy, a barretter or bolometer mount such as the Φ 476A Bolometer Mount is recommended for use in the lower (215- to 940-mc) range. In the 940- to 4000-mc range, a PRD 627A may be used. Verify that the square-law range of the detector is at least 30 db, and operate within the range measured.

5) Tuner -

The tuner can be a slotted-line section in which the sampling probe is replaced with a larger metallic plunger to give a suitably large reflection. The Φ 872A Coaxial Slide Screw tuner is suitable.

6) 50-ohm Load -

The load can be a fixed termination or pad which approximately matches the line (swr less than 2). A Weinschel Engineering Co. 535-FN or -MN Coaxial Termination is suitable.

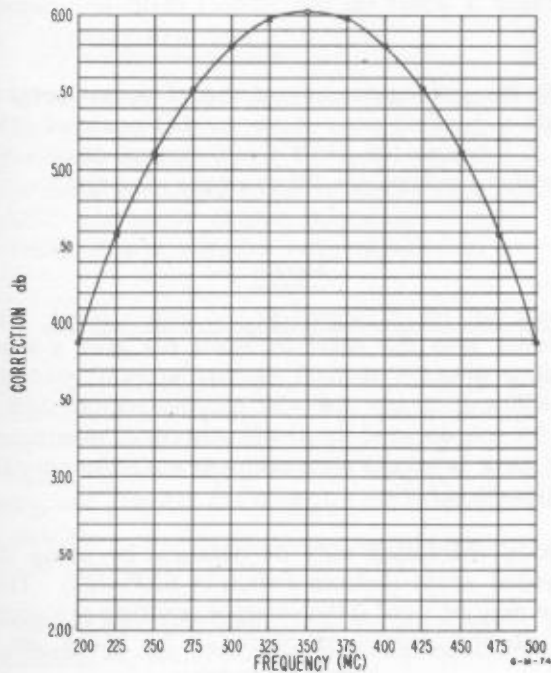

Figure 6. Correction Curve for 200- to 500-mc Line Section

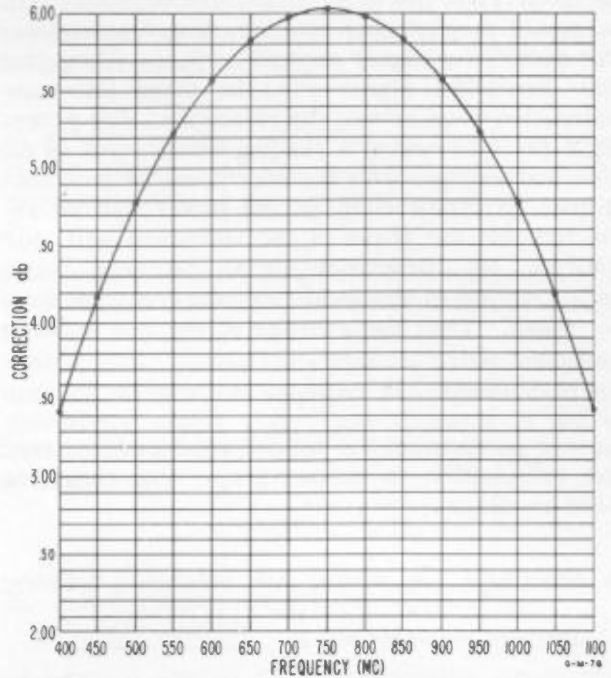

Figure 7. Correction Curve for 400- to 1100-mc Line Section

NOTE

For optimum accuracy, the signal generator output level should be monitored and maintained constant throughout the measurement procedure. For such monitoring, an additional detector and indicator are required.



7) Filter -

To block any harmonics from the generator, use a low-pass filter such as one of the Φ 360 series. See Table I.

B. SET UP

Connect the signal source to the coupler main-line input, detector-indicator No. 1 to the Forward output, and detector-indicator No. 2 to the Reverse output. (Arrangement of equipment is indicated in Figure 5.)

C. SET THE REFERENCE

The reference (S_{ref}) for the measurement is the amplitude of the voltage coupled to the output of the Reverse coupler after complete reflection

of the incident power at the main-line output. The output of the Reverse coupler, however, includes the directivity signal as well as S_{ref} . Therefore the directivity signal must be taken into consideration when setting the reference. The procedure involves taking a reading with a short on the line and another with the line open. In both conditions virtually 100% of the power will be reflected, but the phase of the reflection will shift 180°. The directivity signal, however, which is a fraction of the incident power, remains fixed in phase. Thus the average of the two readings is S_{ref} .

NOTE

Before performing the following procedure, read the information in subparagraph A-2 regarding 415B readings. -----

A procedure for setting the reference follows:

1) Settings for 415B No. 2:

- RANGE switch - - - - - -30 db
- bottom switch - - - - - +5 db
- BOLO CRYSTAL switch - - - - 200KΩ
- GAIN control - - - - - near maximum

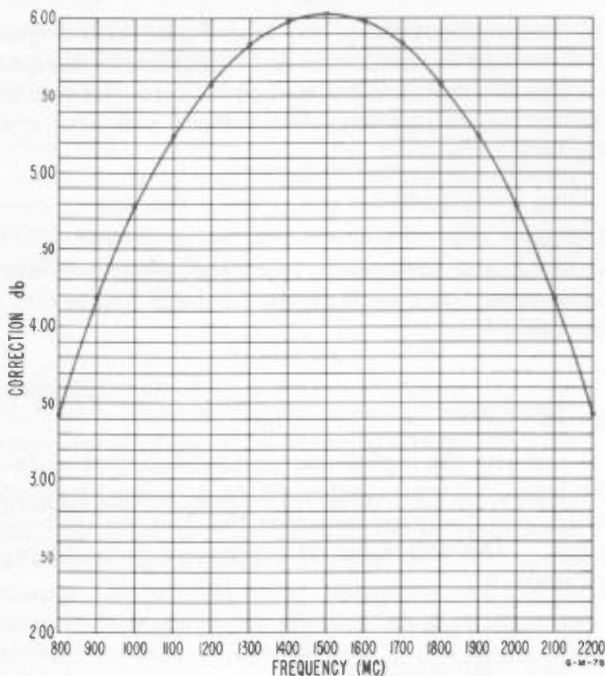

Figure 8. Correction Curve for 800- to 2200-mc Line Section

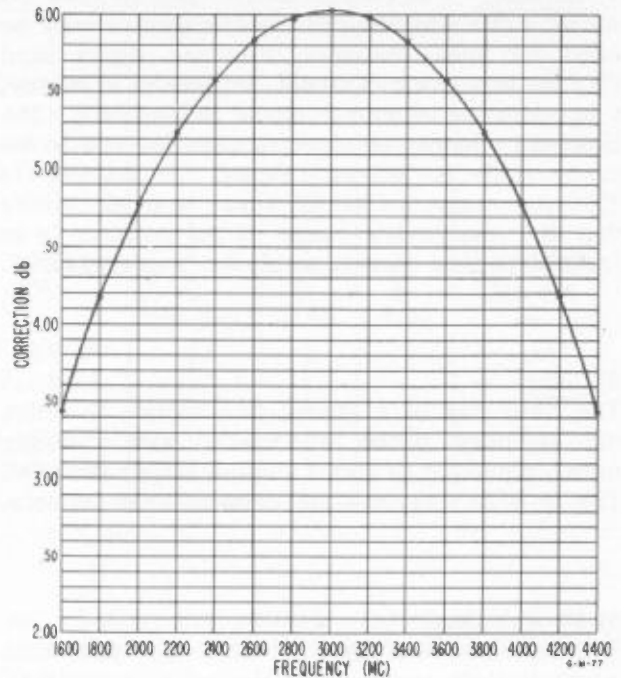

Figure 9. Correction Curve for 1600- to 4400-mc Line Section

2) Place a short on the coupler main-line output.

3) At the generator, adjust the rf output level to obtain a reading near 0 on the DB scale of 415B No. 2. Adjust the 415B GAIN control to obtain a convenient reference, for example -0.4 db.

NOTE

Do not set the rf signal at too high a level. The rf level into the detector must not give a scale reading greater than 0 db on the 415B with the RANGE switch set for -30 db, the bottom switch set for +5 db, and the GAIN control at maximum. This is a level corresponding to a maximum-gain reading of -25 db.

Greater resolution may be obtained by using the expanded scale (bottom switch at EXPAND). This scale may be used if the relative readings are within 2 db of a multiple of 10 db (18-22, 28-32, etc.).

4) Remove the short, and note the reading.

5) Adjust the GAIN control to make the average 0 db. For example:

if reading with short = -0.4 db
 reading with open = -0.2 db
 then average = -0.3 db

Since we want a 0db average, the readings must be moved upscale 0.3 db. With the short on the line, adjust the GAIN control to bring the reading to -0.1 db.

By this procedure a meter reading of 0 db has been obtained for signal S_{ref} at a level corresponding to a maximum gain reading of -25 db. Leave the GAIN control at this setting during the rest of the procedure.

In setting the reference, utilize nearly maximum gain at the 415B so that the input to the detector can be kept as low as possible. It is important that the reference signal operate the detector in the square-law region of its characteristics.

6) Set 415B No. 1 for a convenient reference. Set bottom switch to EXPAND for highest sensitivity.

D. ADJUST FOR NULL

1) Connect the low-reflection end of basic length L1 to the main-line output of the coupler. Push the center conductor of L1 from the open end so the center conductor is in full engagement with the center conductor of the directional coupler connector; this minimizes reflections from the joint.

NOTE

The low-reflection end is the beadless end. In the male-to-female section, the male is the low-reflection end. When using the male-to-male section, remove the screw-on adapters, locate the bead, and connect the opposite end to the directional coupler.

Reasons why the connection to the coupler must be made at the low-reflection end of L1 are discussed in paragraph 5.

2) Connect a tuner such as the Φ 872A Coaxial Slide Screw Tuner to the output of basic length L1.

3) Terminate the tuner with the load (a fixed termination with a swr of less than 2, such as a Weinschel 535-FN or -MN).

4) At the monitor, 415B No. 1, check the level of the signal. At the generator, adjust for the same indication as that set in step C-6.

5) Adjust the tuner plunger, both in penetration and in position, until a null is obtained on 415B No. 2.

With a null, the net reflection (S_3) from the tuner and its termination is equal in magnitude to the directivity signal (S_{dir}) and opposite in phase. The condition that exists is indicated vectorially in Figure 4A.

E. LENGTHEN LINE BY ONE-QUARTER WAVELENGTH

1) Remove section L1, and substitute line section L2 in the setup. Be sure to connect the low-reflection (beadless) end of L2 to the directional coupler, and push the center conductor snug, as in step D-1.

L2 is the section of precision line which is nominally a quarter wavelength longer than L1 at the frequency of the input signal. If the input signal is other than one of the four center frequencies, select the best length to use on the basis of the data presented on the correction curves, Figures 6 to 9.

2) Check that the monitor 415B is indicating the level set in step C-6, and adjust the generator output level, if necessary.

3) Adjust the RANGE switch and -5 db switch to get an upscale meter reading.

4) Read the level indicated on switches and DB scale of 415B No. 2.

Assuming that section L2 is exactly one-quarter wavelength longer than L1 at the frequency of the input signal, S_3 is delayed an additional 180° by the substitution of section L2 for L1. Compensating signal S_3 is now returned in phase with S_{dir} and the total signal voltage at the Reverse output is twice as large as S_{dir} (see Figure 4B).

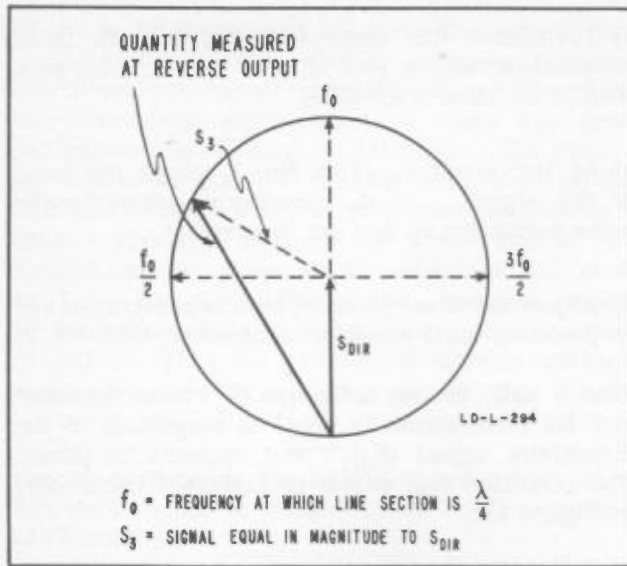

Figure 10. Vector Diagram Indicating Phase Shift of S_3 when Input Signal Frequency is Not Center Frequency of Line Section L2

F. DETERMINE DIRECTIVITY

Where there is exactly one-quarter wavelength difference between L1 and L2 at the frequency of the input signal, the directivity of the reverse coupler is given by the expression

$$\begin{aligned} \text{directivity in db} &= 20 \log \frac{S_{\text{ref}}}{S_{\text{dir}} + S_3} + 6 \text{ db} \\ &= -25 -R + 6 \text{ db} \end{aligned}$$

where: -25 = reference set in step C-5 (-30 -0 +5)

R = reading obtained in step E-4

6 db = correction factor at frequency of input signal (see Figures 6-9).

For example, if in step E-4 the RANGE switch is at -50, the meter at -3, the bottom switch at NORMAL (0), then R is -53, and the directivity is

$$-25 - (-53) + 6 = 34 \text{ db}$$

Where the input signal is other than the center frequency of line section L2, the resultant signal S_3 will be less than twice S_{dir} . Relative signal magnitudes are indicated vectorially in Figure 10. For the correction factor to use in the directivity

equation, see the correction curve (Figures 6 to 9) for the L2 section used. For example, if the input signal is 600 mc, the correction factor is 5.5 db.

G. DIRECTIVITY OF COUPLER NO. 1

Reverse the direction of power flow in the main line, and perform steps C, D, E, and F.

5. PHASE CONSIDERATIONS

For the measurement procedure given in this Operating Note to be valid it must be known that when section L2 is inserted in the line the signal shown as S_3 on Figure 4A does not change in magnitude.

The reflection from the bead at one end of the rigid line is one component of signal S_3 . (The reflections which make up S_3 are indicated in Figure 11.) Since S_3 must not be changed in magnitude when the line is lengthened, both the L1 and L2 sections must be connected with the bead end adjacent to the tuner. If the measurement is made with the bead end adjacent to the coupler, the reflection from the bead becomes a component of S_{dir} , giving an erroneous value to S_{dir} .

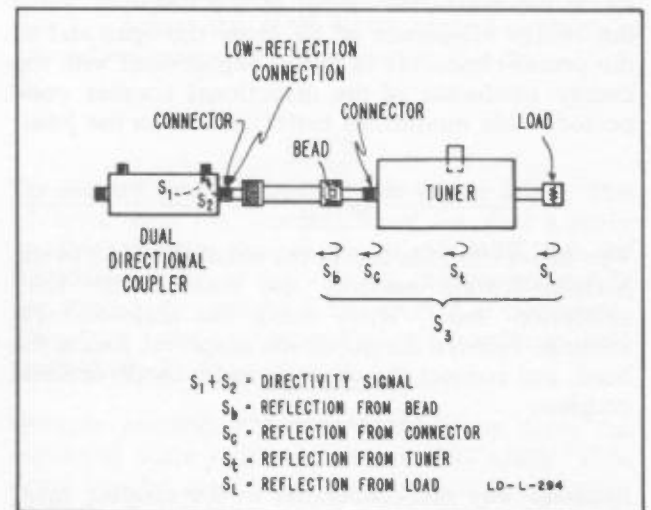

Figure 11. Components of Compensating Signal S_3 , Used in Coaxial Directional Coupler Directivity Measurement



APPLICATION NOTES

HEWLETT-PACKARD COMPANY • 1501 PAGE MILL ROAD • PALO ALTO, CALIFORNIA, U.S.A.
CABLE "HEWPACK" TELEPHONE DAVENPORT 6-7000

APPLICATION NOTE 3 MEASUREMENT OF THE CARRIER FREQUENCY OF RF PULSES *

Alan Bagley and Dexter Hartke
Hewlett-Packard Company
Palo Alto, California

Abstract

The problem of accurate determination of carrier frequency during short rf pulses is discussed. Several methods are described for making such measurements from UHF to X-band, and typical results are given. By one method, a carrier frequency in the vicinity of 1000 which is modulated by 2.5 microsecond pulses at a 30 cycle repetition rate is measured with an accuracy of ± 10 KC.

Introduction

Within the last few years, frequency measuring techniques have been greatly improved by the advent of high-speed electronic counters. These instruments have been applied successfully to the direct measurement of CW signals in the range from DC to a few megacycles. Heterodyne techniques have been used to extend this range into the hundreds of megacycles with accuracies limited mainly by that of present frequency standards.

On examination of the possible requirements for further extension of this range, it becomes apparent that many of the applications of the high end of the spectrum involve microsecond pulses. Although precision wavemeters have been used in pulsed rf applications, there are many cases where accuracies of a higher order of magnitude are required.

The combination of a counter and a transfer oscillator is extremely useful in such applications.

The transfer oscillator is a stable, tunable oscillator whose fundamental frequency lies within the range of CW measuring equipment such as a frequency counter. While its fundamental is monitored by the counter, the oscillator is tuned until one of its harmonics can be compared to the unknown frequency, or until the transfer oscillator fundamental is near a harmonic of the unknown. The accuracy of such a measurement depends to a large extent on the ability of the operator to reduce the difference between the unknown and a harmonic frequency to zero. This in turn depends upon the stability and ease of adjustment of the transfer oscillator as well as the ability of the comparison device to display the magnitude (and possibly the sign) of the difference frequency.

There have been many applications where earphones or a tuning eye are adequate means for obtaining "zero beat". However, when the measured signal is pulse modulated or frequency modulated, the difference signal is also pulse modulated or frequency modulated, and it would appear that a better means of observing the difference frequency is on the face of a cathode-ray tube.

The remainder of this paper will deal with several methods of obtaining useful presentations of the difference signal, with particular attention to pulsed rf signals.

The presentations to be described were obtained with a transfer oscillator whose fundamental covers the range from 100 to 210 MC. The high harmonic content of its output makes it useful for measurements up to 10,000 MC. Its stability and ease of adjustment allow comparisons to well within one part-per-million.

It will be shown that even in the case of short rf pulses, this stability is justified when certain comparison methods are used. One method will be shown which produced accuracies of a few parts in ten-million in the measurement of 10 microsecond pulses of a 1000 MC carrier.

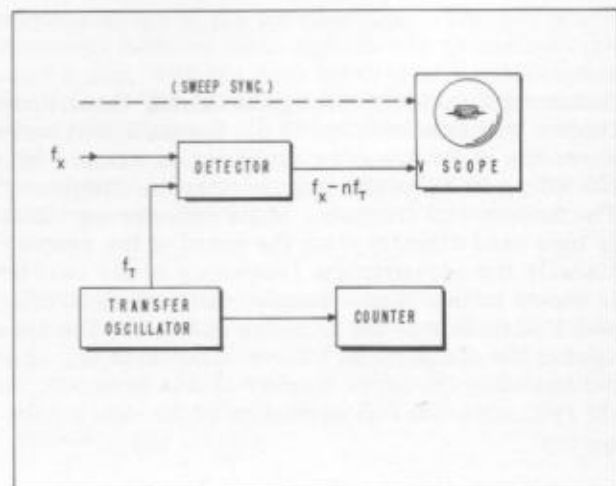

Figure 1. Block Diagram for Pulse Presentation

* Presented at fourth conference on high frequency measurement, Washington, D. C., January 19, 1955.

Pulse Presentation

Figure 1 illustrates the most obvious method of observing a difference signal. The detector output is connected directly to the vertical input terminal of a C-R oscilloscope. When f_x consists of pulses of rf, the detector output will consist of the difference frequency, pulse modulated. As the transfer oscillator is adjusted to bring this difference frequency within the bandwidth of the oscilloscope amplifier, one might expect the appearance of a trace similar to Figure 2A, assuming a properly established horizontal sweep. However, it is very unlikely that the cycles of the difference signal will be synchronized with the pulse envelope, and the multiple trace of Figure 2B is a more accurate representation. Notice that approximately five cycles of the difference frequency are shown within the pulse envelope. For a 1 microsecond pulse, this would correspond to a difference frequency of 5 megacycles. As this error is further reduced by careful tuning of the transfer oscillator, traces similar to Figures 3A, B and C will appear. In Figure 3A, one cycle of the difference frequency appears during the pulse while Figures 3B and 3C depict difference frequencies of one-tenth of a cycle per pulse width and one-hundredth of a cycle per pulse width respectively.

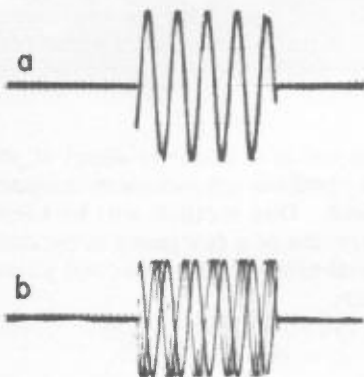

Fig. 2. Pulse Presentation showing (a) single trace, and (b) multiple trace

Assuming a 1 microsecond pulse width, these three figures will then indicate to the operator that some harmonic of the transfer oscillator is within 1 MC, 100 KC or 10 KC of the unknown carrier frequency. The fundamental frequency of the transfer oscillator is then read directly from the panel of the counter. Usually the approximate frequency of the carrier is known so that it is a simple matter to determine which harmonic of the transfer oscillator has been used in the comparison. The counter reading, when multiplied by the order number of this harmonic, is the final accurate representation of the carrier frequency.

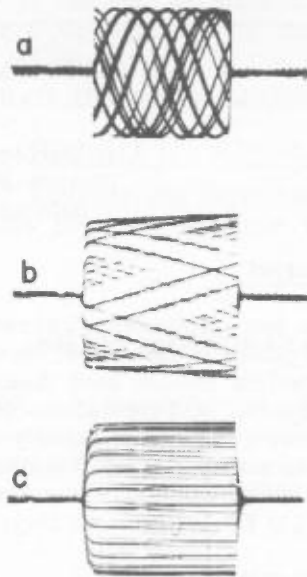

Fig. 3. Pulse Presentation for difference frequencies of (a) one, (b) one-tenth, and (c) one one-hundredth cycle-per-pulse-width

If the harmonic order is not known, it can be quickly determined by tuning the transfer oscillator until an adjacent harmonic falls on the carrier frequency. If the original frequency of the transfer oscillator is f_1 and the new setting is at a frequency of f_2 , the carrier frequency is given by Nf_1 where N is a simple integer given by

$$N = \frac{f_2}{(f_1 - f_2)}$$

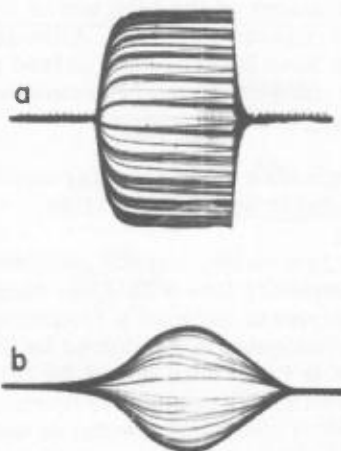

Fig. 4. Pulse Presentation of (a) limited bandwidth, and (b) gaussian pulse

Figure 4A indicates a small amount of deterioration in the presentation due to bandwidth limitation, and Figure 4B illustrates the case of Gaussian Pulse Modulation. In all cases "zero beat" is approached by attempting to produce some traces having no vertical deflection. If there is FM present during the

pulse, this will not be possible, but horizontal underdeflected lines may be produced during various portions of the pulse, and the amount of FM can be measured by this means. Video bandwidth limitation has been found useful in cases of excessive noise or "ringing" on the modulating pulse.

Although the above technique was used very successfully at pulse repetition rates of from 50 cps to 5 KC, it was noticed that excessive crowding of traces at high repetition rates resulted in a slight loss in accuracy. A presentation that does not require the resolution of individual traces is illustrated in Figure 5.

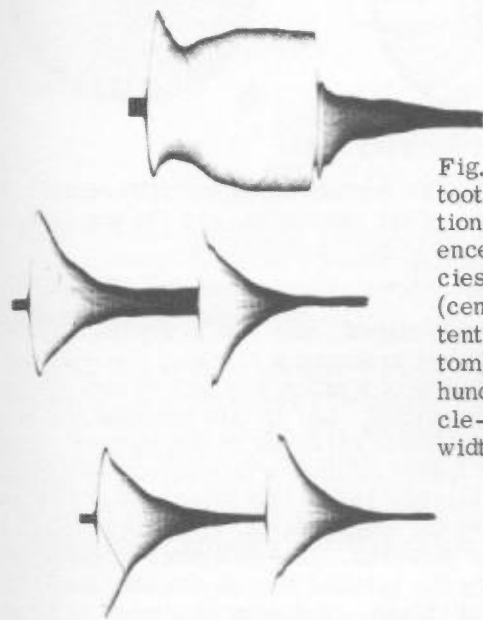

Fig. 5. Sawtooth Presentation for difference frequencies of (top) one, (center) one-tenth, and (bottom) one one-hundredth cycle-per-pulse-width

Sawtooth Presentation

This presentation was obtained by inserting a simple RC differentiating circuit ahead of the vertical input terminal on the oscilloscope in Figure 1. The time constant of this RC circuit should be on the order of one-tenth of the pulse width. Zero beat is then indicated by the first exponential envelope decaying to a sharp point. With too short a time constant, convergence will occur in spite of a relatively high difference frequency, while with too long a time constant, convergence will not occur even at zero beat. This is indicated by Figures 5A, 5B, and 5C, which illustrate respective difference frequencies of one, one-tenth, and one-hundredth cycle-per-pulsewidth.

Direction of Error

Although both of the above presentations tell the operator roughly how far he is from zero beat, they completely lack information as to whether he is

above or below that point. Such information would be an obvious aid to the tuning procedure. The detection method indicated in Figure 6 preserves this information by supplying two difference frequency outputs whose relative rf phase indicates the sign of the frequency difference. Methods of presenting the information contained in these two outputs are described below.

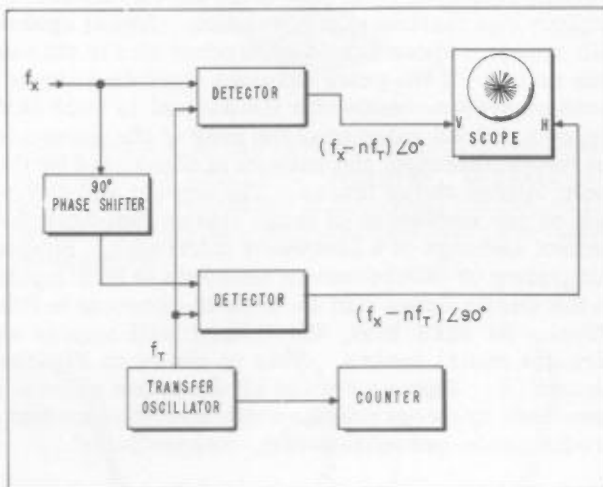

Fig. 6. Block Diagram for Spoke Presentation

Spoke Presentation

In Figure 6, two detectors are arranged so as to receive signals from the transfer oscillator in the same phase, while signals from the input terminal arrive at one detector after a phase shift of 90°. Thus, two difference frequency signals are produced which differ in rf phase by 90°.*

Assume for the moment that a CW signal is being measured and that the resulting CW difference frequency signals are connected to the horizontal and vertical inputs of the oscilloscope. The 90° phase difference between these signals will produce a circular trace, with the spot rotating at the difference frequency. The direction of rotation will be determined by the sign of the difference frequency. Thus, as the transfer oscillator is tuned through zero beat the rotation will slow down, stop, and then proceed in the opposite direction.

* The results shown were obtained with the two detectors spaced one-eighth wavelength apart (at f_x) on a section of line fed by f_x at one end and f_t at the other. The resulting 45° phase shift in each signal produces the desired 90° difference in the phases of the outputs.

The circle will have a radius which is determined by the amplitude of the CW input signal and will degenerate to a point when that signal disappears.

Thus, a burst of rf due to pulse modulation will cause the trace to jump to the circumference of the circle, rotate for a number of revolutions determined by the difference frequency, and then return to a point in the center of the circle. If the difference frequency is reduced so that only a fraction of a cycle occurs during each pulse, the trace will be on the circumference for only that fraction of a revolution. Radial spokes will appear, whose intensity depends on the rate of rise or fall. If the pulse envelope (including any effects of system bandwidth limitation) is such that the rise and fall rates near the peak of the pulse are markedly different, the pattern is dominated by the more intense radial traces. The amount and direction of any curvature of these traces indicates the amount and sign of a frequency difference. Simple integrating or differentiating networks at both inputs to the oscilloscope can be used to accentuate this effect. At zero beat, the traces will appear as straight radial spokes. This is shown in Figures 7A and 7B. Figures 8A and 8B illustrate errors of one-tenth cycle-per-pulsewidth and one one-hundredth cycle-per-pulsewidth, respectively.

The direction of error feature of this presentation has proved to be an aid to both speed and accuracy of measurement. A series of tests using the spoke presentation at various pulse repetition rates has indicated that there again is some loss in accuracy due to a crowding of traces at high rates.

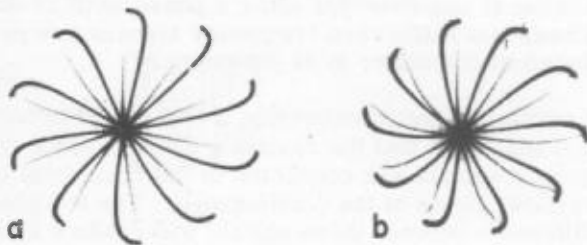

Fig. 7. Spoke Presentation for Transfer Oscillator harmonic (a) above, and (b) below carrier frequency of pulse

Pointer Presentation

As far as pulse work is concerned, this novel presentation has the advantage of being an envelope display which does not require the resolution of individual traces. In Figure 9 is shown the rather simple modification of the circuit of Figure 6 which produces

this particular presentation. A simple RC low pass filter is inserted in the vertical deflection circuit and a high pass filter is inserted in the horizontal deflection circuit. These circuits have a crossover frequency f_c which is given by $f_c = 1/2\pi RC$. Their transfer functions are such as to produce an additional 90° of phase difference between the vertical and horizontal inputs at all frequencies.

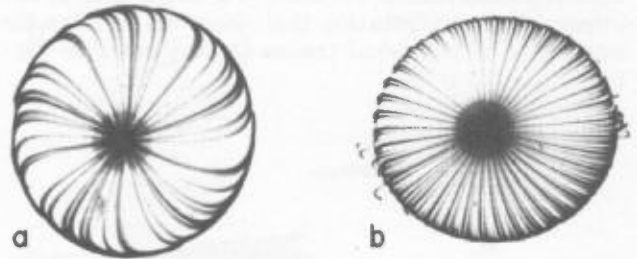

Fig. 8. Spoke Presentation for difference frequencies of (a) one-tenth, and (b) one one-hundredth cycle-per-pulsewidth

In analyzing this circuit, note that in Figure 6 a CW difference signal produced a circular trace whose direction and rate of rotation was determined by the difference frequency. Let us now examine the effect of the crossover networks on this pattern. The additional 90° phase difference transforms the circle back into a straight line. The slope of this line is determined by the amplitude vs. frequency characteristic of the networks. Low difference frequencies are passed by the vertical circuit and attenuated by the horizontal circuit, producing an almost vertical line. High difference frequencies are passed by the horizontal circuit and attenuated by the vertical circuit, producing a line of low slope. As the transfer oscillator is tuned through zero beat, the phase of the horizontal signal reverses with respect to the phase of the vertical signal. Thus, for CW, a straight line trace is produced whose angular deflection from the vertical axis increases with difference frequency, the sign of this deflection indicating whether the transfer oscillator frequency is high or low. The deflection is 45° at a difference frequency equal to the crossover frequency. The similarity of this presentation to a zero center meter presentation is obvious, and indeed a true meter presentation can be obtained by feeding the two oscilloscope inputs into a pure product modulator instead.

Figures 10A, 10B, and 10C illustrate the presentation for a CW signal which is respectively below, "on" and above a harmonic of the transfer oscillator. The usual low frequency cutoff of the vertical amplifier produces a very sharp null indication at zero beat.

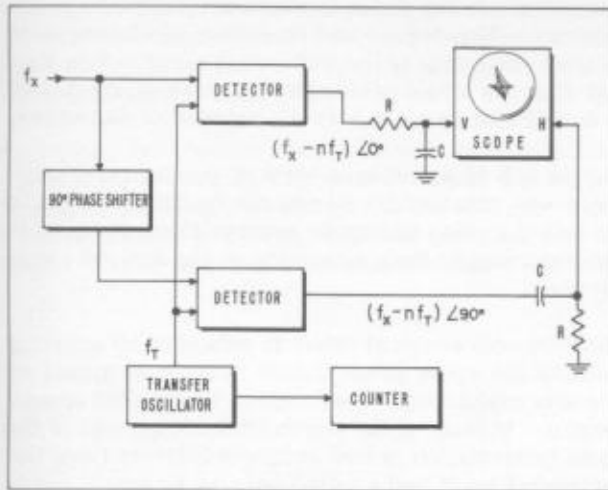

Fig. 9. Block Diagram for Pointer Presentation

Figure 11A is the pattern obtained with a varying frequency below that of the transfer oscillator harmonic. Figure 11B indicates a widely varying frequency which sweeps through zero beat.

Figure 12 was obtained with a signal containing both amplitude and frequency modulation. In Figure 12A, the transfer oscillator was adjusted to obtain zero beat at the trough of the amplitude modulation. In Figure 12C the transfer oscillator was adjusted to measure the frequency at the peak of amplitude modulation and Figure 12B indicates an intermediate setting.



Fig. 10. Pointer Presentation for CW signal (a) below, (b) "on", and (c) above harmonic of Transfer Oscillator

The wide spectrum due to pulse modulation produces patterns such as shown in Figure 13. Again, Figures A, B, and C indicate carrier frequencies below, "on", and above the transfer oscillator harmonic. This pattern was obtained with a 10 microsecond pulse and a crossover frequency of 100 KC.

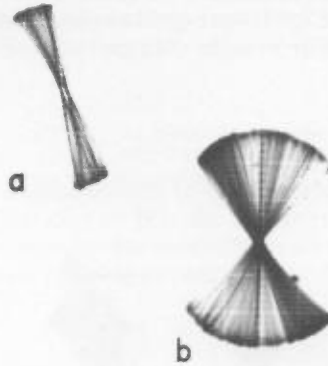

Fig. 11. Pointer Presentation for (a) varying frequency below zero beat, and (b) frequency which swings through zero beat

This presentation has obvious merit as a non-sweeping spectrum analysis. However, at pulse rates which permit resolution of individual traces, slightly better accuracy has been obtained using the "spoke" presentation.

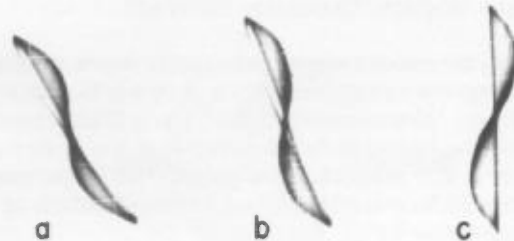

Fig. 12. Pointer Presentation for simultaneous FM and AM with zero beat at (a) trough, (b) average, and (c) peak of modulation

Accuracy

Figure 14 shows the distribution of 120 frequency readings using the "spoke" presentation at various repetition rates. The distribution curve for readings at all rates indicates an rms error of only 2 or 3 parts in ten-million. Thirty readings were taken at each rate. The individual distribution curves indicate an increase in accuracy with increasing rate up to about 1000 pps. The accuracy has started to deteriorate at 5000 pps, apparently due to the crowding of traces. At higher pulse rates, an envelope display as in Figure 5 of 13 is indicated.

Due to the increase in frequency spectrum with decreasing width in a modulating pulse, a figure of merit for such pulsed rf measurement is the fractional part of a difference frequency cycle which occurs during the pulse. In general, all of the systems described here have produced measurement accuracies on the order of one one-hundredth of a cycle-per-pulsewidth. The accuracy indicated by Figure

14, where all of the readings are within plus-or-minus one two-hundredth of a cycle-per-pulsewidth, is two or three times better than results obtained with other presentations.



Fig. 13. Pointer Presentation for pulse modulation of carrier which is (a) below, (b) "on", and (c) above Transfer Oscillator harmonic

These measurements were made under more or less ideal laboratory conditions with a very stable source of pulsed rf. Measurements made on a DME transmitter in the field produced errors on the order of 10 KC for a 2.5 microsecond pulse. This corresponds to a difference frequency of one-fortieth of a cycle-per-pulsewidth.

"3-D" Presentations

Certain similarities in the behavior of the various presentations described above led to speculation that all of the presentations could be regarded as different views of a three-dimensional form which represents the difference signal as variously modified by system bandwidth limitations. This form lies along the time axis and its dimensions in any plane perpendicular to that axis are given by the instantaneous amplitudes of the quadrature components of difference signal.

Figure 15 shows the three projections of the imaginary solid which originally led to this speculation. The top view is the so-called "sawtooth presentation". The end view is the pointer presentation and the side view is the pulse presentation under limited bandwidth.

A form which is easier to visualize is the skewed

squirrel cage whose end view is the spoke presentation and whose top and side views are the pulse presentation. The degree and direction of skewness is a direct indication of the difference error. It is logical that one would prefer the end view in attempting to detect and correct a small amount of skewness.

Figure 16B is an oblique view of the squirrel cage which was obtained by mixing the horizontal signals for both the pulse and spoke presentations in amounts corresponding to their projection on the desired viewing plane.

The three-dimensional effect is enhanced by applying some of the spoke presentation horizontal signal as intensity modulation. The brighter traces then appear nearer. In fact, if the horizontal component of the spoke presentation is now removed entirely from the horizontal input and applied only as intensity modulation, one obtains the pulse presentation with only the "nearer" traces displayed. Both the sense and magnitude of the error is indicated by the slopes of these traces. Figure 17A and 17B illustrate this presentation for the case of a carrier which is sinewave modulated in both amplitude and frequency. In Figure 17A a zero beat is obtained at the peak of amplitude modulation while in Figure 17B the frequency is being determined at the trough.

Conclusion

The combination of transfer oscillator and precision frequency counter constitutes a system capable of rapid and accurate frequency measurements well into the microwave region.

The error in this method of frequency measurement arises in the -

- (1) comparison of a harmonic of the transfer oscillator to the carrier frequency.
- (2) determination of the transfer oscillator fundamental frequency.

Several techniques have been described which show the advantages of cathode ray tube displays in making the comparison, particularly in the case of pulse modulated signals. Quadrature detection may be employed to provide an indication of the direction of the comparison error as well as its magnitude. The choice of the particular display to be used is dictated largely by the complexity of the signal to be measured and the accuracy desired.

The accuracy of comparison in the case of pulsed rf

depends upon the product of pulse width and carrier frequency. When this product exceeds ten thousand cycles, the comparison error can be reduced to the point where a counter error of a few parts in ten million is significant.

In general, the transfer oscillator with an appropriate comparison system can be used to extend the applicability of the frequency counter to the measurement of instantaneous frequency over an extremely wide range. The accuracy of such measurements depends

upon the number of rf cycles used as a sample in the comparison.

Acknowledgement

The authors wish to acknowledge the many helpful suggestions of Dr. B. M. Oliver, with particular reference to the methods used to determine the direction of comparison error.

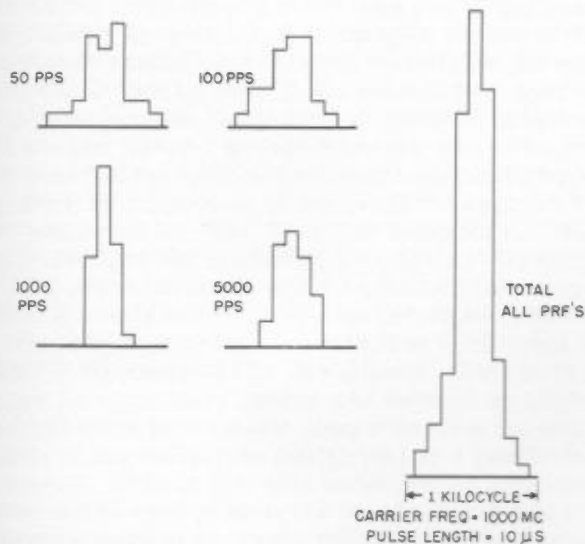

Fig. 14. Distribution of 120 readings using Spoke Presentation

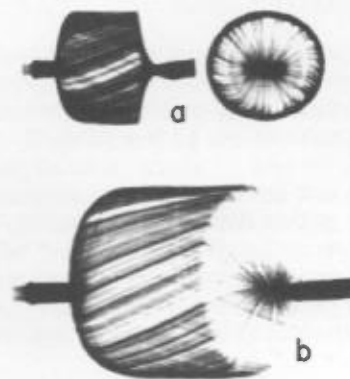

Fig. 16. "Squirrel Cage" shown in (a) side view, and (b) oblique view

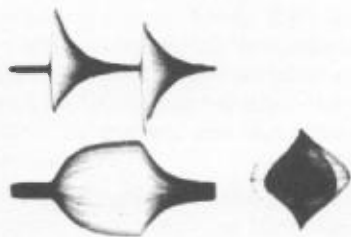

Fig. 15. Three presentations as projections of a solid figure

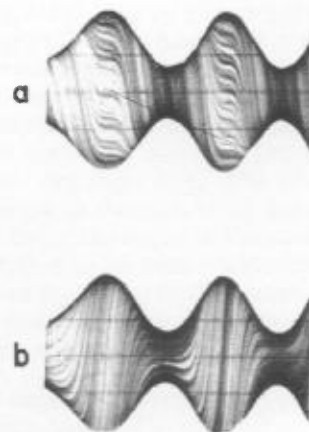

Fig. 17. Intensity modulated presentation for combination of AM and FM with zero beat at (a) peak, and (b) trough

ANALYSIS OF MICROWAVE MEASUREMENT TECHNIQUES BY MEANS OF SIGNAL FLOWGRAPHS

J. K. Hunton
Hewlett-Packard Company
Palo Alto, Calif.

Abstract

Microwave measurement techniques can be analyzed more simply by using signal flowgraphs, instead of the customary scattering matrices, to describe the microwave networks used in the measuring system. This is because the flowgraphs of individual networks are simply joined together when the networks are cascaded and the solution for the system can be written down by inspection of the overall flowgraph by application of the Non-Touching Loop Rule. This paper reviews the method of setting up flowgraphs of microwave networks and the rule for their solution. A single directional-coupler reflectometer system for measuring the reflection coefficient of a load is then analyzed by this method. The analysis shows how auxiliary tuners can be used to cancel residual error terms in the measurement of the magnitude of the reflection coefficient at a particular frequency. The analysis also shows how an additional tuner can be used to measure the phase angle of the reflection coefficient. These reflectometer techniques are particularly useful in the measurement of very small reflections.

Introduction

The signal flowgraph is a method of writing a set of equations, whereby the variables are represented by points and the interrelations by directed lines, giving a direct picture of signal flow. The algebra of flowgraphs leading to solutions by direct inspection has been developed by S. J. Mason and others at M. I. T.^{1, 2} When microwave network equations are written in scattering matrix form, the corresponding flowgraph is particularly useful, because in this case the flowgraph of a system of cascaded networks is constructed simply by joining together the flowgraphs of the individual networks, and the solution is then available directly.

One of the best applications of the flowgraph method is in the analysis of measuring techniques and the determination of residual errors. It is the intention here to review the mechanics of the method and to apply it in analyzing the microwave reflectometer system used for measuring the reflection coefficient of a load. This system has been in general use for some time,³ and has been analyzed recently by Engen and Beatty,⁴ who showed how tuners could be used to reduce residual errors to a negligible value when

measuring the magnitude of the reflection coefficient. Their result will be derived here by the flowgraph method. In addition, a technique for measuring the phase angle of the reflection coefficient will be presented.

One- and Two-Port Network Flowgraphs

Figure 1 shows some simple flowgraphs used as building blocks. In Figure 1 (a) the general two-port network is shown as specified by its scattering matrix coefficients. Here a_1 and a_2 are the complex-entering-wave amplitudes, while b_1 and b_2 are the outgoing-wave amplitudes at ports 1 and 2 of the network. These are represented in the flowgraph as points or "nodes". The "nodes" are related to one another by directed lines (signal flow) marked with appropriate coefficients. These are the scattering coefficients S_{11} , S_{12} , S_{21} , S_{22} . Their meaning is derived from the equations:

$$b_1 = S_{11} a_1 + S_{12} a_2$$

$$b_2 = S_{21} a_1 + S_{22} a_2$$

Here S_{11} is the reflection coefficient (b_1/a_1) at port 1 when port 2 is terminated in a matched load (in this case $a_2 = 0$). S_{22} is the reflection coefficient (b_2/a_2) at port 2 when port 1 is matched ($a_1 = 0$). S_{12} is the transmission coefficient (b_1/a_2) from port 2 to port 1 when port 1 is matched ($a_1 = 0$). S_{21} is the transmission coefficient (b_2/a_1) from port 1 to port 2 when port 2 is matched ($a_2 = 0$). In all reciprocal networks $S_{12} = S_{21}$. The value of each node in the flowgraph is the sum of all signals entering it, each signal being the value of the node from which it comes multiplied by its path coefficient. The independent variables a_1 and a_2 in the equations represented by the flowgraph are characterized by signal flow directed into the graph.

Figure 1(b) depicts a termination or load whose reflection coefficient is Γ_L .

Figure 1(c) shows a mismatched generator. Here E is the wave amplitude at the port when the generator sees a matched load ($a = 0$), and Γ_g is the reflection coefficient looking into the port when E is zero.

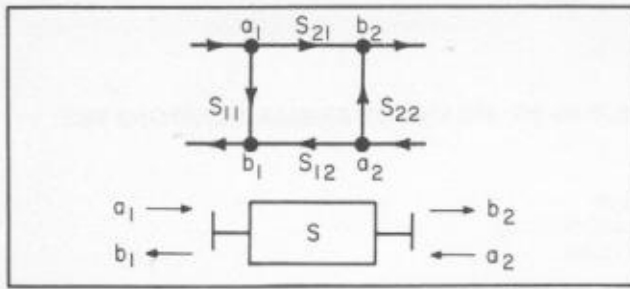

Figure 1 (a) - Two-Port Network

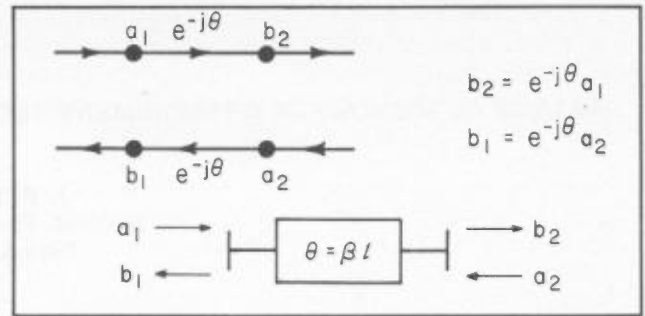

Figure 1 (e) - Lossless-Line Length

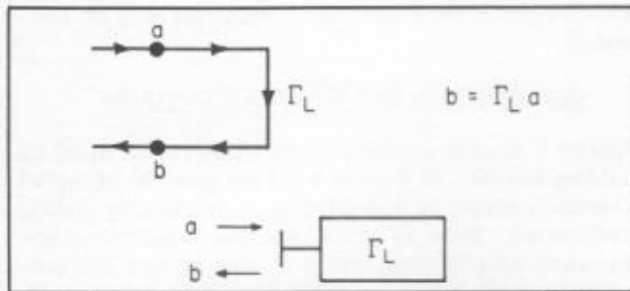

Figure 1 (b) - Load

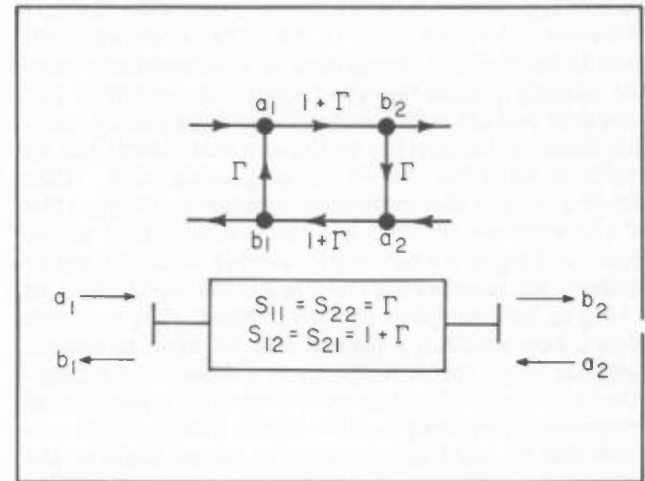

Figure 1 (f) - Shunt Admittance

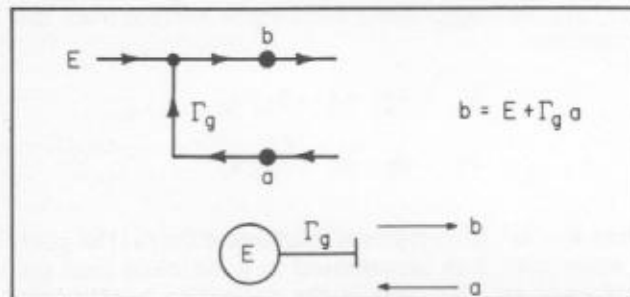

Figure 1 (c) - Generator

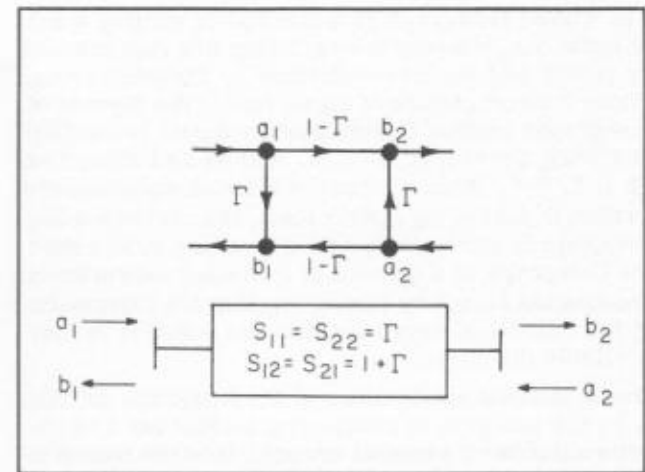

Figure 1 (g) - Series Impedance

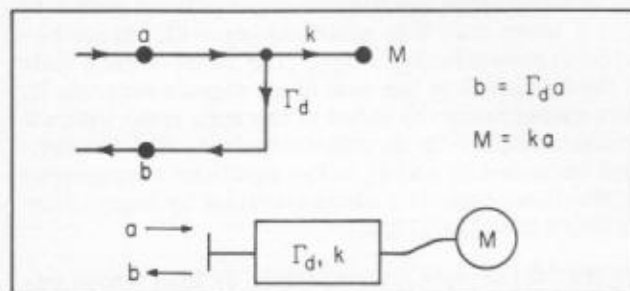

Figure 1 (d) - Video Detector

Figure 1(d) shows a video detector (such as a crystal or a barretter mount). Γ_d is the detector reflection coefficient at the port, and k is a scalar conversion efficiency relating the incoming-wave amplitude to a meter reading M . It is assumed that this meter is calibrated to take account of the detector law, so that k is independent of signal level. It is also assumed that Γ_d is independent of signal level. (Both these conditions are satisfied very nearly with detectors used in reflectometer systems when used in their proper operating range.)

Figure 1(e) depicts a length of lossless transmission line.

Figure 1(f) is a shunt discontinuity, such as a junction between two lines or a probe which can be considered as a shunt admittance. The coefficient $S_{11} = S_{22} = \Gamma$ is the reflection coefficient which would be measured if the discontinuity were followed by a matched load. The coefficient $S_{12} = S_{21} = 1 + \Gamma$ follows from the fact that the net wave amplitudes on either side of the discontinuity must be equal. The coefficient Γ is related to the normalized shunt admittance Y by

$$\Gamma = - \frac{Y}{Y + 2}$$

Figure 1(g) is a lumped series impedance. Here the coefficient Γ is related to the normalized series impedance Z by

$$\Gamma = \frac{Z}{Z + 2}$$

The "Non-Touching Loop" Rule

When networks are cascaded, it is only necessary to cascade the flowgraphs, since the outgoing wave from one network is the incoming wave to the next. This is demonstrated in Figure 2 where a network is placed between a generator and a load. The system now has only one independent variable, the generator amplitude E . The flowgraph contains paths and loops. A "path" is a series of directed lines followed in sequence and in the same direction in such a way that no node is touched more than once. The value of the path is the product of all coefficients encountered en route. In the figure there is one path from E to b_2 . It has a

value S_{21} . There are two paths from E to b_1 , namely S_{11} and $S_{21} \Gamma_L S_{12}$. A first-order "loop" is a series of directed lines coming to a closure when followed in sequence and in the same direction with no node passed more than once. The value of the loop is the product of all coefficients encountered en route. A second-order loop is the product of any two first-order loops which do not touch at any point. A third-order loop is the product of any three first-order loops which do not touch, and so on. In Figure 2 there are three first-order loops, namely, $\Gamma_g S_{11}$, $S_{22} \Gamma_L$, and $\Gamma_g S_{21} \Gamma_L S_{12}$ and there is one second-order loop $\Gamma_g S_{11} S_{22} \Gamma_L$.

The solution of a flowgraph is accomplished by application of the non-touching loop rule^{5,6}, which written symbolically is:

$$T = \frac{\left\{ \begin{aligned} &P_1 (1 - \Sigma L(1)^{(1)} + \Sigma L(2)^{(1)} - \Sigma L(3)^{(1)} + \dots) \\ &+ P_2 (1 - \Sigma L(1)^{(2)} + \Sigma L(2)^{(2)} - \dots) \\ &+ P_3 (1 - \dots) \end{aligned} \right\}}{1 - \Sigma L(1) + \Sigma L(2) - \Sigma L(3) + \dots}$$

Here $\Sigma L(1)$ denotes the sum of all first-order loops. $\Sigma L(2)$ denotes the sum of all second-order loops, and so on. P_1, P_2, P_3 , etc., are the values of all the various paths which can be followed from the independent-variable node to the node whose value is desired. $\Sigma L(1)^{(1)}$ denotes the sum of all first-order loops which do not touch path P_1 at any point, and so on. In other words, each path is multiplied by the factor in brackets which involves all the loops of all orders which that path does not touch. T is a general symbol representing the ratio between the dependent variable of interest and the independent variable. This process is repeated for each independent variable of the system, and the results are summed.

As examples of the application of the rule, the transmission (b_2/E) and the reflection coefficient (b_1/a_1) are written as follows:

$$\frac{b_2}{E} = \frac{S_{21}}{1 - \Gamma_g S_{11} - S_{22} \Gamma_L - \Gamma_g S_{21} \Gamma_L S_{12} + \Gamma_g S_{11} S_{22} \Gamma_L}$$

$$\frac{b_1}{a_1} = \frac{S_{11} (1 - S_{22} \Gamma_L) + S_{21} \Gamma_L S_{12}}{1 - S_{22} \Gamma_L}$$

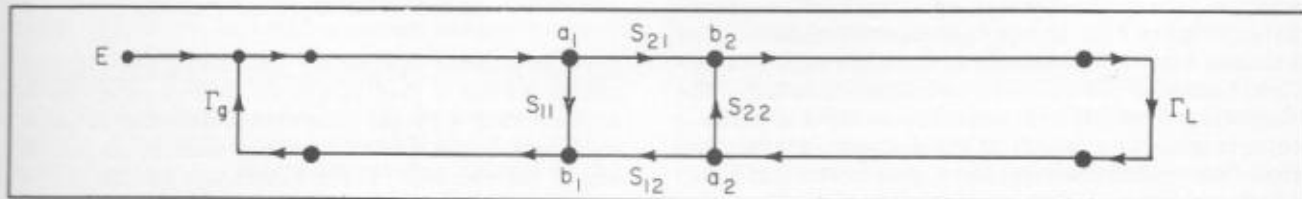

Figure 2 - Cascading of a Network Between Load and Generator

Note that the generator flowgraph is unnecessary when solving for b_1/a_1 , and the loops associated with it are deleted when writing this solution. It is worth mentioning at this point that second- and higher-order loops can quite often be neglected while writing down the solution, if one has orders of magnitude for the various coefficients in mind.

Three-Port Network

The flowgraph of the general three-port network with the third port terminated by a detector is shown in Figure 3(a). The equations described by the flowgraph are:

$$b_1 = S_{11} a_1 + S_{12} a_2 + S_{13} a_3$$

$$b_2 = S_{21} a_1 + S_{22} a_2 + S_{23} a_3$$

$$b_3 = S_{31} a_1 + S_{32} a_2 + S_{33} a_3$$

$$a_3 = b_3 \Gamma_d$$

$$M = k b_3$$

(note also the $S_{12} = S_{21}$, $S_{13} = S_{31}$, $S_{23} = S_{32}$ for reciprocal networks).

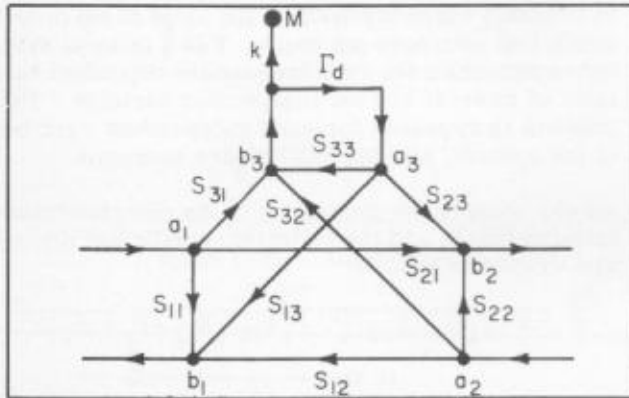

Figure 3 (a) - Three-Port Network with Detector

Since only two rf ports are available with this combination, the flowgraph can be simplified considerably. Figure 3(b) shows this simplification. The symbols for the coefficients are chosen with a directional coupler-detector combination in mind. The directional coupler is assumed to have a built-in termination in one end of its secondary arm, and the other end of the secondary arm is the third port which is terminated by a video detector. The relationships involved are:

$$b_1 = \Gamma_1 a_1 + T a_2$$

$$b_2 = \Gamma_2 a_2 + T a_1$$

$$M = k (C a_1 + C D a_2)$$

$$\Gamma_1 = S_{11} + \frac{S_{13}^2 \Gamma_d}{1 - S_{33} \Gamma_d}$$

$$\Gamma_2 = S_{22} + \frac{S_{23}^2 \Gamma_d}{1 - S_{33} \Gamma_d}$$

$$T = S_{21} + \frac{S_{13} S_{23} \Gamma_d}{1 - S_{33} \Gamma_d}$$

$$C = \frac{S_{31}}{1 - S_{33} \Gamma_d}$$

$$D = \frac{S_{32}}{S_{31}}$$

These relationships are written directly through application of the non-touching loop rule. Note that the path a_1 to M is the main coupling direction involving an effective coupling coefficient C , and the path a_2 to M is the residual coupling direction involving the coupling factor and effective directivity coefficient D . For a directional coupler, the coupling factor as usually defined is $20 \log |(1/S_{31})|$, while the directivity is $20 \log |(S_{31}/S_{32})|$.

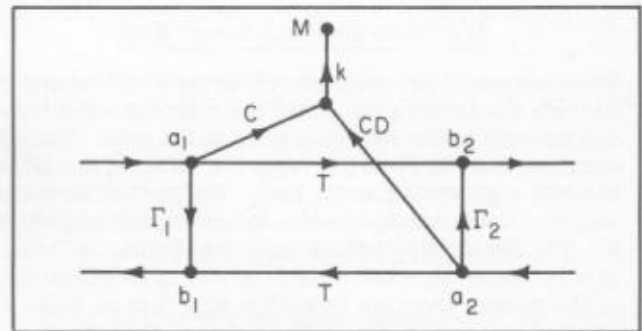

Figure 3 (b) - Directional - Detector

Single-Coupler Reflectometer

A reflectometer system for measuring the reflection coefficient of a load is shown in Figure 4. In this arrangement a single directional-detector is used in conjunction with two slide-screw tuners, one at each end of the coupler. These tuners are for the purpose of cancelling residual signals, which can cause a measurement error. They consist of a probe of ad-

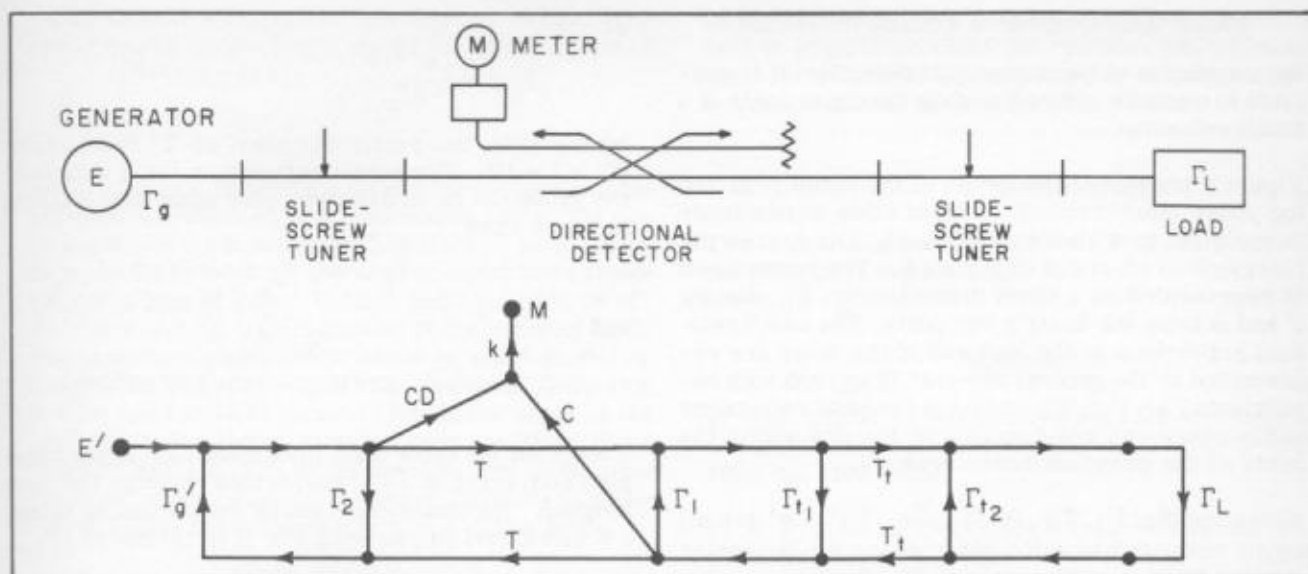

Figure 4. Single-Coupler Reflectometer

justable penetration projecting into the line through a slot along which the probe position can be varied. In the flowgraph of the system the generator reflection is lumped together with the generator reflection as Γ_g' , and the load tuner is represented as a general two-port network with coefficients Γ_{t1} , Γ_{t2} and T_t . The analysis carried out in the appendix shows that Γ_g' can be made equal to any arbitrary value by proper adjustment of the generator tuner (although E varies with the adjustment), and Γ_{t1} can be made any arbitrary value by proper adjustment of the load tuner.

The solution for the meter reading M is

$$M = \left| CkE' \frac{(D + T\Gamma_{t1}) + \Gamma_L(T\Gamma_t^2 - T\Gamma_{t1}\Gamma_{t2} - D\Gamma_{t2})}{\left\{ (1 - \Gamma_g'/\Gamma_2 - \Gamma_g'/\Gamma_{t1}T^2 - \Gamma_1\Gamma_{t1}) - \Gamma_L(\Gamma_g'/T^2T_t^2 + \Gamma_1T_t^2 + \Gamma_{t2} - \Gamma_g'/T^2T_t\Gamma_{t2}) \right\}} \right|$$

This assumes that connector or flange joint reflections are lumped within the tuner networks, and that the coupler coefficients Γ_1 , Γ_2 , D are small compared to unity. All third- and higher-order loops are negligible, and second-order loops involving Γ_1 or Γ_2 are negligible. These approximations are quite valid for practical systems and simplify the algebra considerably. Since the meter reading M is not directly proportional to Γ_L , the reflectometer system as it stands can not give an accurate result. The procedure for achieving the accurate relationship is as follows:

- (1) Adjust the load tuner.

Terminate the system with a low-reflection phaseable load. The Γ_L term in the denominator is then negligible by comparison with the constant term, whereas the Γ_L term in the numerator is comparable to the constant term. As the load is moved, the meter reading will vary. By adjusting Γ_{t1} such that no variation occurs, the constant term in the numerator can be brought to zero. This means $\Gamma_{t1} = -(D/T)$.

- (2) Adjust the generator tuner.

The system is now terminated with a phaseable short circuit. As this is moved, the meter reading varies as a result of the beating between the Γ_L term and the constant term in the denominator. By proper adjustment of Γ_g' , the Γ_L term can be made zero. That is,

$$\Gamma_g' = \frac{\Gamma_1 T_t^2 + \Gamma_{t2}}{T^2 \Gamma_{t1} \Gamma_{t2} - T^2 T_t^2}$$

With this adjustment no variation in M occurs as the short is moved.

- (3) The meter reading is now directly proportional to Γ_L . That is, $M = K \Gamma_L$. The meter reading is adjusted to the reference value of unity by adjustment of a gain control. If now an unknown load is connected to the system the meter will accurately measure the magnitude of its reflection coefficient. In a practical case it may be necessary to apply corrections to the meter readings to take account of small deviations of the detector law from the meter law.

Phase Measurement of a Small Reflection

By a variation of the method just described it is possible to measure quite accurately the phase angle of a small reflection.

Figure 5 shows the flowgraph of the setup required for phase measurement. A third slide-screw tuner is included just ahead of the load. Otherwise the flowgraph is identical to Figure 4. The probe itself is represented as a shunt discontinuity, Γ_p , distant θ and ϕ from the tuner's two ports. The small residual reflections at the load end of the tuner are represented by the general two-port flowgraph with coefficients Γ_1' , Γ_2' , T' , while the residual reflections at the other end are considered lumped within the ports of the previous tuner network.

Assuming that $\Gamma_1, \Gamma_2, D, \Gamma_{t1}, \Gamma_{t2}, \Gamma_1', \Gamma_2'$ are all small compared to unity, the solution for the meter reading M is

$$M \cong CK E' \frac{\left\{ \begin{aligned} &D + T\Gamma_{t1} + T\Gamma_{t2}^2 \Gamma_p e^{-2j\theta} \\ &+ T\Gamma_{t2}^2 e^{-2j(\theta+\phi)} (1+2\Gamma_p)\Gamma_1' \\ &+ T\Gamma_{t1}^2 T'/2 (1+2\Gamma_p) e^{-2j(\theta+\phi)} \Gamma_L \end{aligned} \right\}}{1 - \Sigma L(1) + \Sigma L(2) \dots}$$

The probe is first removed, making Γ_p zero, and $|\Gamma_L|$ is then measured by the previous procedure of Figure 4. During this procedure the tuner coefficient Γ_{t1} will have been adjusted to bring to zero the sum of all terms in the numerator not involving Γ_L .

That is

$$D + T\Gamma_{t1} + T\Gamma_{t2}^2 e^{-2j(\theta+\phi)} \Gamma_1' = 0$$

The probe is now inserted and adjusted in depth and position until M is zero. The result is

$$\Gamma_L = \frac{\Gamma_p e^{+2j\phi}}{1+2\Gamma_p} \left(\frac{1}{T_1'^2} + \frac{2\Gamma_1'}{T_1'^2} e^{-2j\phi} \right)$$

or

$$\Gamma_L \cong \frac{-\Gamma_p e^{+2j\phi}}{1+2\Gamma_p} (1-2t'+2\Gamma_1' e^{-2j\phi})$$

where t' is the small deviation of T' from unity ($T' = 1 + t'$). For small reflections (less than 0.2) the probe can be considered a pure shunt susceptance, in which case

$$\Gamma_p = \frac{-jB_p}{2+jB_p}$$

and

$$\Gamma_L \cong \frac{jB_p}{2-jB_p} e^{+2j\phi} (1-2t'+2\Gamma_1' e^{-2j\phi})$$

Except for the error term in brackets, Γ_L is the complex conjugate of Γ_p transformed through the line length ϕ . The phase angle can be determined by using a Smith chart or, solving for B in terms of $|\Gamma_L|$,

$$\angle \Gamma_L = 2\phi - \tan^{-1} \frac{(1-|\Gamma_L|^2)^{1/2}}{|\Gamma_L|}$$

The maximum error in the measurement of the phase angle is then

$$\sin^{-1} (2|t'| + 2|\Gamma_1'|)$$

If the tuner probe is not lossless but has a small shunt conductance G_p associated with it, the maximum error becomes

$$\sin^{-1} (2|t'| + 2|\Gamma_1'| + \frac{G_p}{B_p})$$

However, if the greatest accuracy is desired, the probe conductance could be measured and the phase angle corrected. If a slotted line with the same residual discontinuities as the tuner is used, the effective load reflection measured would be

$$\Gamma_L (1+2t' + \frac{\Gamma_1'}{\Gamma_L})$$

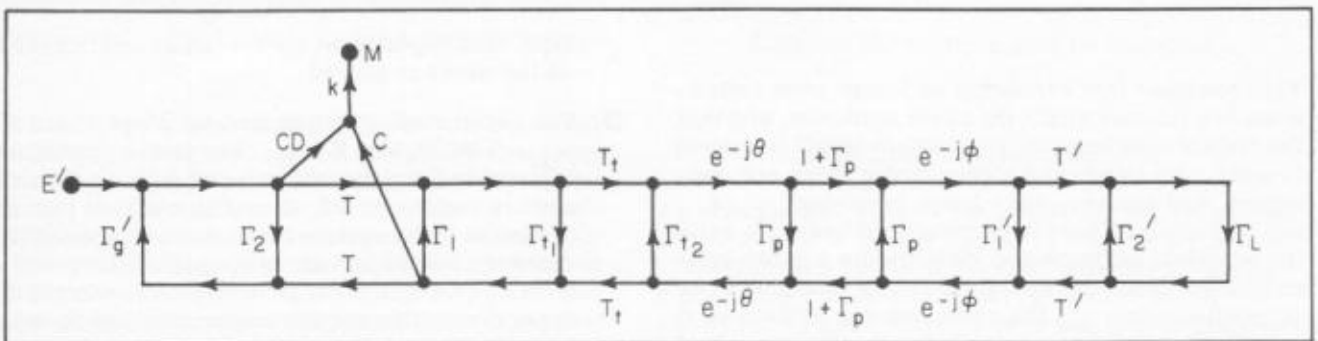

Figure 5- Phase Measurement with Single-Coupler Reflectometer

There is both a magnitude and a phase error. The error in the phase angle would be of the order of

$$\sin^{-1}(2|t'| + |\frac{\Gamma_L'}{\Gamma_L}|)$$

As an example, consider a case where a phase measurement is required of a load whose reflection coefficient has a magnitude of 0.03 (SWR = 1.06). Suppose the tuner used for the measurement has a residual reflection of 0.01. Then t' and Γ_L' could be of the order of 0.01. (G_p/B_p) can be of the order of 0.05. The maximum phase error would be $\sin^{-1}(0.09)$, or 5 degrees. If a slotted line with a residual reflection of 0.01 were used to measure the phase angle of the load reflection, the maximum error would be of the order of $\sin^{-1}(0.35)$, or 20 degrees, not to mention the error which could occur through inability to accurately locate the minimum in the standing wave.

Conclusion

The chief advantages of flowgraph over matrix algebra in solving cascaded networks are the convenient pictorial representation and the painless method of proceeding directly to the solution with approximations being obvious in the process. The flowgraph method is particularly useful in analyzing a measurement technique to determine residual-error magnitudes.

The reflectometer techniques described are mainly applicable to the measurement of small reflection loads. The use of tuners in the magnitude measurement results in a cancellation of residual-error signals. In the phase-measuring method, the residual-error signals are merely depressed, since a further probe insertion is required to make the measurement

after "flattening" the system. This depression becomes important when the residual reflections in the system are of the same order of magnitude as the reflection to be measured.

Acknowledgment

The author wishes to thank Dr. P. D. Lacy for his many helpful suggestions.

References

- 1) S. J. Mason, "Feedback Theory - Some Properties of Signal Flowgraphs", Proc. IRE, vol. 41, No. 9, Sept., 1953, pp. 1144-1156.
- 2) S. J. Mason, "Feedback Theory - Further Properties of Signal Flowgraphs", Proc. IRE, vol. 44, No. 7, July, 1956, pp. 920-926.
- 3) J. K. Hunton & N. L. Pappas, "The -hp- Microwave Reflectometers", Hewlett-Packard Journal, vol. 6, No. 1-2, Sept. - Oct., 1954.
- 4) G. F. Engen & R. W. Beatty, "Microwave Reflectometer Techniques", IRE Transactions on Microwave, Theory & Techniques, vol. MTT-7, No. 3, July, 1959, pp. 351-355.
- 5) C. S. Lorens, "A proof of the Non-Intersecting Loop Rule for the Solution of Linear Equations by Flowgraphs", MIT Research Laboratory of Electronics Quarterly Progress Report, Jan., 1956, pp. 97-102.
- 6) W. W. Happ, "Lecture Notes on Signal Flowgraphs", University of California Extension Course - "Analysis of Transistor Circuits", No. 834AB.

APPENDIX

The Slide-Screw Tuner

The slide-screw tuner consists of a probe of adjustable penetration projecting into a line through a slot along which its position can be adjusted. The probe itself can be regarded as a purely shunt discontinuity. In addition there are fixed discontinuities at the ends of the slot and at the connectors or flange joints. It is desirable to lump all the fixed discontinuities at the two ports of the network. To show that this can be done, consider the flowgraph of a shunt discontinuity followed by a length of lossless line, as in Figure 6(a).

Here β is the electrical length of the line section and Γ is the reflection coefficient of the discontinuity when backed up with a matched load. The flowgraph follows from considering that the complex-wave amplitudes on either side of the discontinuity must be equal. The discontinuity can be transferred to the other port, as shown in Figure 6(b).

In either case the scattering coefficients are

$$S_{11} = \Gamma, \quad S_{22} = \Gamma e^{-2j\beta}, \quad S_{12} = S_{21} = (1 + \Gamma) e^{-j\beta}$$

If a further discontinuity is present at the right-hand port, the two can be lumped together and described by the flowgraph of Figure 6(c), where

$$\Gamma_1 = \frac{\Gamma e^{+2j\beta} + \Gamma' + 2\Gamma\Gamma'}{1 - \Gamma\Gamma' e^{-2j\beta}}$$

$$\Gamma_2 = \frac{\Gamma' + \Gamma e^{-2j\beta} + 2\Gamma\Gamma' e^{-2j\beta}}{1 - \Gamma\Gamma' e^{-2j\beta}}$$

$$\Gamma = \frac{e^{-2j\beta} (1 + \Gamma)(1 + \Gamma')}{1 - \Gamma\Gamma' e^{-2j\beta}}$$

For small reflections, the tuner probe is a lossless shunt discontinuity and is equivalent to a shunt capacitive susceptance. The relationship between normalized susceptance β_p and probe reflection coefficient Γ_p is

$$\Gamma_p = \frac{-j\beta_p}{2 + j\beta_p}$$

The complete flowgraph of a slide-screw tuner is shown in Figure 6(d), where all the fixed reflections beyond the probe are now lumped at the two ports.

It is desirable to represent the tuner by a two-port flowgraph with three coefficients. In order that this be useful, however, it is necessary to show that the S_{11} and S_{22} coefficients can be made equal to any arbitrary value by proper adjustment of Γ_p and θ . This can be done in two steps. Consider first the case with no discontinuity at port 1. The S_{11} coefficient is then

$$\frac{\Gamma_p e^{-2j\phi} + \Gamma_2' e^{-2j(\theta + \phi)} + 2\Gamma_p \Gamma_2' e^{-2j(\theta + \phi)}}{1 - \Gamma_p \Gamma_2' e^{-2j\theta}}$$

Consider the possibility of making this same arbitrary value k . This is a simple problem to solve using a Smith chart. One would start with a reflection coefficient Γ_2' at port 2 and move toward the generator until reaching a point at which the reflection

$$\Gamma_2' e^{-2j\theta}$$

and the reflection

$$k e^{+2j\phi}$$

were represented on the chart by admittances with the same conductance value. The probe would be inserted at this point until its susceptance equalled the difference between the susceptances at the points representing the two reflections.

Stated analytically these conditions are

$$\Gamma_p = \frac{-j\beta_p}{2 + j\beta_p}$$

$$k e^{+2j\phi} = \frac{1 - G - j\beta_k}{1 + G + j\beta_k}$$

$$\Gamma_2' e^{-2j\theta} = \frac{1 - G - jB'}{1 + G + jB'}$$

$$B_p = B_k - B' \quad [B_p, \text{positive}]$$

Substitution of these conditions in the expression for S_{11} above does give the results $S_{11} = k$. Since the S_{11} coefficient can be made equal to any arbitrary value, k , when the fixed port 1 reflection is absent, it is obvious that the S_{11} coefficient for the complete system can be made equal to any arbitrary value, a . The value is

$$a = \frac{\Gamma_1''(1 - k\Gamma_1') + \tau_1^2 k}{1 - k\Gamma_1'}$$

or

$$k = \frac{\Gamma_1'' - a}{\Gamma_1''/\Gamma_1' - \tau_1^2 - \Gamma_1'/a}$$

The slide-screw tuner can now be represented as a two-port device with three coefficients, as shown in Figure 6(e), and we can conclude that Γ_1 or Γ_2 can be made any arbitrary value by adjustment of the probe.

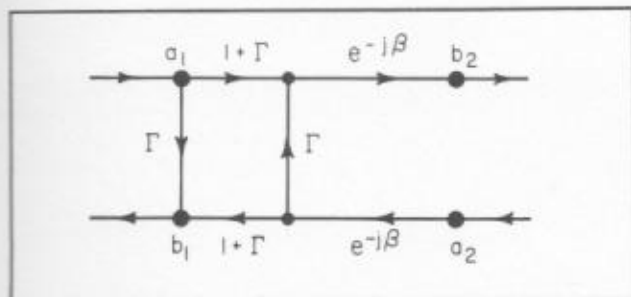

Figure 6 (a) - Shunt Discontinuity Followed by a Length of Lossless Line

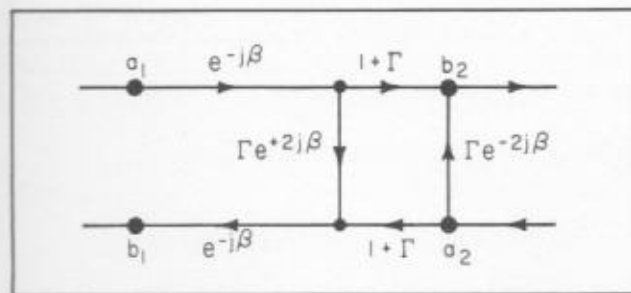

Figure 6 (b) - Equivalent Discontinuity Referred to the Other Port

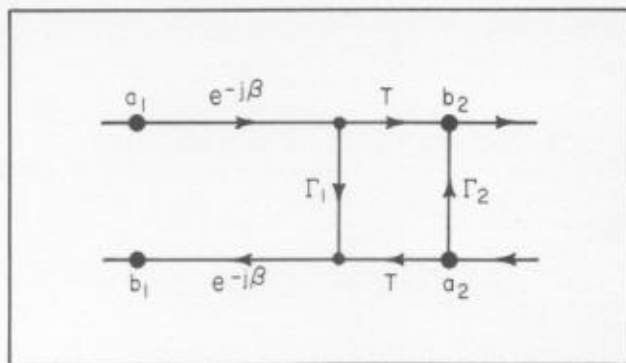

Figure 6 (c) - Additional Discontinuity Included at the Port

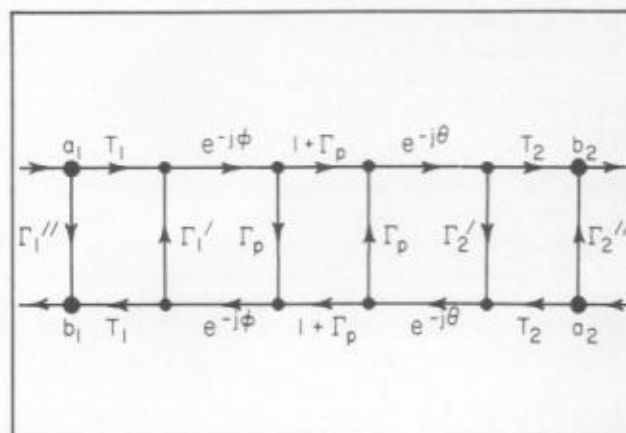

Figure 6 (d) - Complete Flowgraph of the Slide-Screw Tuner

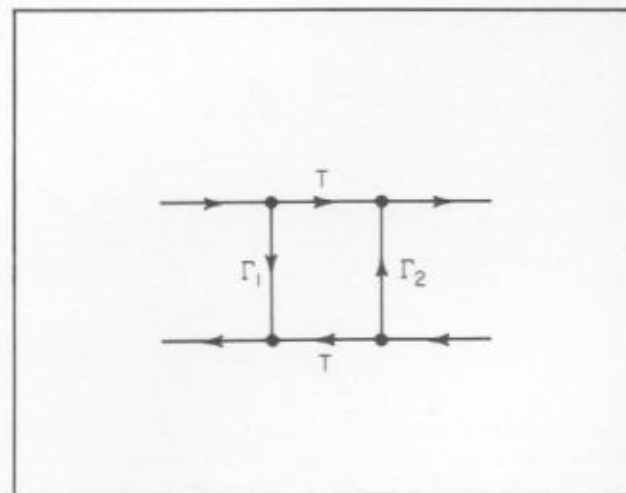

Figure 6 (e) - Equivalent Slide-Screw Tuner Flowgraph

The first part of the document is a list of names and their corresponding addresses. This section is organized into a table with four columns. The first column contains the names, the second column contains the street addresses, the third column contains the city names, and the fourth column contains the state abbreviations.

The second part of the document is a list of names and their corresponding addresses. This section is organized into a table with four columns. The first column contains the names, the second column contains the street addresses, the third column contains the city names, and the fourth column contains the state abbreviations.

The third part of the document is a list of names and their corresponding addresses. This section is organized into a table with four columns. The first column contains the names, the second column contains the street addresses, the third column contains the city names, and the fourth column contains the state abbreviations.

The first part of the document is a list of names and their corresponding addresses. This section is organized into a table with four columns. The first column contains the names, the second column contains the street addresses, the third column contains the city names, and the fourth column contains the state abbreviations.

The second part of the document is a list of names and their corresponding addresses. This section is organized into a table with four columns. The first column contains the names, the second column contains the street addresses, the third column contains the city names, and the fourth column contains the state abbreviations.

The third part of the document is a list of names and their corresponding addresses. This section is organized into a table with four columns. The first column contains the names, the second column contains the street addresses, the third column contains the city names, and the fourth column contains the state abbreviations.

The fourth part of the document is a list of names and their corresponding addresses. This section is organized into a table with four columns. The first column contains the names, the second column contains the street addresses, the third column contains the city names, and the fourth column contains the state abbreviations.

