



SAMPLING OSCILLOGRAPHY*

by

R. Carlson, S. Krakauer, K. Magleby, R. Monnier, V. Van Duzer, R. Woodbury

Hewlett-Packard Co.
Palo Alto, CaliforniaINTRODUCTION

Analogous to sampling is the operation of a stroboscope for closely observing mechanical events which occur too fast for the eye to follow. Sampling-like strobe flashes when synced with an event's occurrence, or to some multiple of it, will give the appearance of stopped motion; object motion during light-pulses will determine image resolution. By slightly delaying the pulse the event will appear to occur later on in time, and if done progressively and sequentially, the total episode can then be examined in as much detail as pulse duration and rate of progression will permit. The impression of continuous action is due to the rapidity and number of light pulses and after-image effect of the eye, so that separate events merge into a consecutive order.

The ability of the sampling oscilloscope to respond and store rapid bits of information and present them in a continuous display is correspondingly similar. And it is this ability that enables the sampling oscilloscope to sidestep the usual limitations inherent in conventional high frequency oscilloscopes: limited sensitivity and bandwidth, and small display size. The sampling technique immediately translates the input signal into a lower frequency domain where conventional low frequency circuitry can be used effectively.

The sampling technique was used over a hundred years ago^{3,6,8} to overcome the frequency response limitations of existing electrical measuring instruments. Its use antedated by many years the development of Blondel's electromagnetic oscillograph in 1893 and Braun's cathode-ray tube in 1897.

Lenz⁶ and 1849 and later Joubert⁶ in 1880 determined alternator wave forms by sampling. An electrostatic voltmeter was connected to the alternator output through a momentary contactor, actuated by rotation of the alternator shaft. The angular position of the contactor brush defined the point in the alternator cycle being sampled, and the voltmeter registered its amplitude at that point. Scanning was accomplished by manually shifting the contactor brush.

In 1898 Callendar improved the convenience of this method by having a separate, synchronous motor drive the commutator, thereby permitting remote operation. Automatic scan was achieved by gearing down the commutator drive for brush rotation, and a self balancing potentiometer was used for wave form recording as a function of time. This device required 45 minutes to reproduce one cycle. Callendar¹ discussed the desirability of coupling the recording paper's displacement with that of the commutator brush, but he did not include this in his instrument.

In 1904 Hospitalier⁴ developed a similar but more practical and faster instrument called the Ondograph. It was commercially produced in Europe for thirty years. A somewhat less automatic, but highly accurate device known as the Rosa curve tracer was manufactured in this country.

Only fairly recently has sampling again served to extend the bandwidth of existing instruments. In 1950 Janssen⁵ built a 35 mc sampling oscilloscope. This instrument was capable of use only with high repetition rate signals. Sampling rate was close to 100 kc, and scanning was accomplished by position modulating the sampling pulses at power line frequency.

McQueen⁷ developed the first commercial sampling oscilloscope in 1952. This instrument had the very respectable bandpass of 300 mc and a repetition rate capability from 100 to 4000 cps. Both Janssen and McQueen sampled by mixing a fast pulse with the input signal in a vacuum tube. In 1957 Sugarman⁹ used a microwave diode sampling switch to give his oscilloscope a band pass of 600 mc. In the same year, Chaplin² described a sampling oscilloscope using transistors operated in the avalanche mode to generate the time base and sampling pulse. Chaplin's unit, completely transistorized and of 350 mc bandwidth, was in the form of an attachment for a conventional oscilloscope. Commercial sampling oscilloscopes are now produced with bandwidths in the "GC" range.

The drive toward higher bandwidths has, of course, proceeded concurrently along other avenues than that of sampling. Indeed, the traveling wave oscilloscope is presently capable of bandwidths comparable to the best achieved with sampling; moreover, it can record single transients. The difficulty with its use lies in its small display size, low sensitivity, low brightness on low duty cycle, and low sweep speed.

In contrast, the sampling oscilloscope display size is as great as conventional low frequency oscilloscopes: the sensitivity is high, the presentation is bright and clearly visible in high ambient light - regardless of duty cycle - and the linear time bases are very fast. In general, sampling presents almost none of the problems afflicting the usual high frequency oscilloscopes, yet offers most of the advantages of conventional oscilloscopes, exemplified by multiple trace capability.

GENERAL SAMPLING CONSIDERATIONS

An oscilloscope is usually used to show the instantaneous amplitude of a signal as a function of the elapsed time from some reference.

The sampling oscilloscope differs from the conventional type in that each recurrence of the input signal produces only a single point, corresponding to the signal amplitude at the time of sampling, rather than a continuous curve. If successive elapsed times

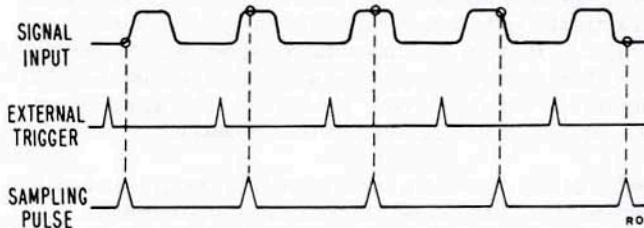

Figure 1

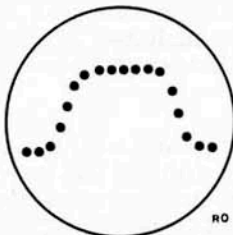

Figure 2

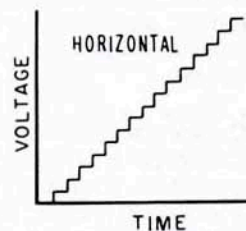

Figure 3

Figures 1-3. Sampling Technique

The sampling oscilloscope samples the amplitude of the input waveform at successive points along the waveform instead of continuously monitoring it as in a conventional oscilloscope. Each sample is taken at a progressively later point on the waveform as shown in figure 1. The samples provide the vertical deflection (figure 2) and are plotted simultaneously with a staircase signal (figure 3) which provides the horizontal deflection. The staircase signal advances one step after each sample is taken, thus forming the time base. By displaying a large number of points, a continuous display results.

are varied from a fixed reference, then different points will be plotted, and a curve will be defined (see figures 1-3). The manner or sequence in which elapsed time is varied can be arbitrary since only the point's plotted order and trace density are affected; point density, though, will determine how continuous the curve will appear. The entire curve is progressively and cyclically sampled. The time interval for the sampling act must necessarily be finite, and this time together with the charging time-constant of the sampling circuit limits the possible rise-time or bandwidth, thus limiting resolution.

These same factors also determine transfer loss of the sampling circuit, called sampling efficiency. By reducing the charging time-constant, both bandwidth and sampling efficiency can be improved; but, decreasing the sampling time will improve bandwidth only at the expense of sampling efficiency, for any given time constant.

BANDWIDTH VS SAMPLING EFFICIENCY

The sampling circuit is seen as consisting of a time varying conductance (sampling gate) in series with a fixed capacitance (amplifier input); the output of this circuit, after sampling, is the voltage on capacitor "C", which is assumed to discharge completely between sampling acts. The time function is the elapsed time determined by the interval between the input signal and conductance function. Now, to see how response of the sampling circuit is influenced by the sampling and the charging times, consider the effects of an input signal and the associated transient response which is displayed: Assuming that the switching conductance function $g(t)$ is rectangular with amplitude "G" and duration "T", the charging time-constant will then be defined as $T = C/G$. The conventional transient response of this "C", "G" circuit to a voltage impulse can be computed by usual means to yield:

$$e_c = \frac{1}{\tau} \epsilon^{-t/\tau} \quad \text{for } 0 < t$$

If an impulse is now considered to be scanned by the sampling gate, taking the stored value at termination of the gate as the sampled amplitude, and time as the interval between the trailing edge of the gate and the impulse, then a similar wave will be reproduced except that it will be cut off at a time which corresponds to the gate length.

$$e_{c1} = \frac{1}{\tau} \epsilon^{-t/\tau} \quad \text{for } 0 < t < T$$

$$e_{c1} = 0 \quad \text{for } t > T$$

Because an impulse has a flat frequency spectrum, the frequency transform of the impulse response will yield frequency response of the system.

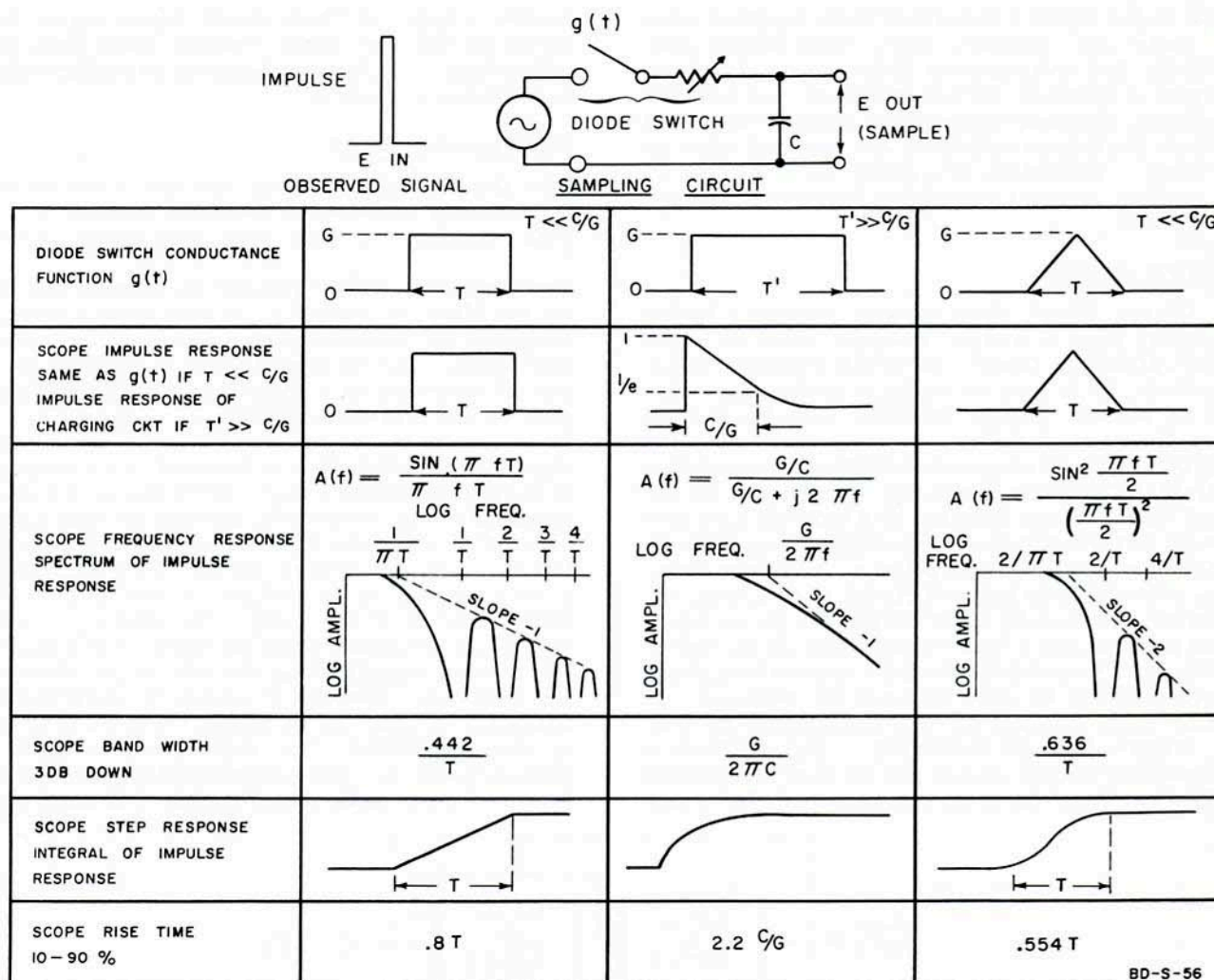

Figure 4. Sampling Oscilloscope Frequency Response

$$A(f) = \frac{1 - e^{-\frac{T}{\tau}} (1 + j 2 \pi f \tau)}{1 + j 2 \pi f \tau}$$

For the cases where $\tau \gg T$ and $\tau \ll T$, the wave shapes degenerate to the forms given in columns 1 and 2 in figure 4. The responses for an assumed triangular $g(t)$ with $\tau \gg T$ are shown in column 3.

Sampling efficiency falls out of the above expression easily since it is equivalent to the DC gain of the system.

$$S. E = A(0) = 1 - e^{-T/\tau}$$

In practice the effective overall rise time of a sampling oscilloscope can be held close to the sampling duration limit. Subsequent amplifier rise time determines only the speed with which the point is plotted and need be compatible only with maximum repetition rate capability.

THE hp SAMPLING OSCILLOSCOPE

The Hewlett-Packard sampling oscilloscope, using fast switching conventional and step-recovery diodes,

is a dual trace unit with a bandwidth of DC to 1 GC. Separate inputs are needed for the trigger and signal channels, a minimum advanced trigger of .1 microsecond being necessary before initiation of the signal to be observed.

The trigger signal can be as low as 15 millivolts and still be applied directly to the 50 Ω terminated input at the front panel or, alternatively, the accessory trigger probe may be used. It has a 1 K Ω input impedance for minimizing circuit loading at operating frequencies, but requires a 50 mv signal for stable triggering.

In case a suitable, advanced trigger is not available, the hp 1100A Delay Line will provide the correct delay for the signal so that the proper triggering sequence will occur; but, when this is done it becomes necessary to sacrifice use of one of the high impedance probes for one that is terminated in the characteristic impedance of the delay line, 50 Ω .

For the signal input, high impedance probes of 100 k Ω in parallel with 2 pf are used to insure best signal reproduction. Both probes (only one channel is

shown in the figure 5 simplified block diagram) contain their own sampling gate, each having four extremely fast diodes, prior to the input and cathode follower; a feedback circuit stabilizes and controls sensitivity. Dynamic range of the probes are governed by diode breakdown voltage on one hand and noise on the other. Deflection sensitivity is 3 mv/cm to 200 mv/cm, external attenuation required for higher input levels.

TRIGGER CIRCUIT

The trigger signal after passing through a buffer amplifier, used to reduce reaction from the input circuit, is fed to a tunnel diode which triggers a pulse generator. It in turn produces a rectangular pulse both of slightly greater duration than the longest sweep time and of faster rise time than that of the ramp in the time-base circuit which the pulse generator controls. The pulse generator, triggered from the tunnel diode, is then inhibited by a hold-off circuit to prevent further response from trigger signals until equilibrium of all circuits returns. Maximum repetition rate which the hold-off circuit allows, directly, is 100 kc; however, by using the high frequency input, which incorporates a count-down oscillator to produce pulses at some submultiple of the applied frequency, synchronization to 1000 mc can be realized. A vernier on the hold-off duration provides control over any trigger hold-off instability. For calibration purposes the trigger circuit may be free run: pulsing a step recovery diode elicits an output that shock

excites a high "Q" tank circuit whose signal when connected to the signal channel gives real time calibration. Amplitude calibration is available from a calibrated dc source.

TIME BASE CIRCUIT

Two things originate from the time-base circuit: (1) sampling initiation to the signal channel, (2) scan time control for the horizontal sweep channel.

The time-base circuit imposes an ordered sequence on the time of sampling, so that each successive sampling is displaced later in time by some fixed increment. Circuit performance centers about the mutual operation of a transistor-tunnel-diode comparator and a staircase generator. Sequentially, the events begin when the trigger signal unclamps a capacitor, charged from a constant current source, to initiate a voltage ramp. When the ramp voltage, being fed to the comparator, reaches the step voltage level of the staircase, the comparator fires and moves the staircase up one step; the firing voltage initiates a sampling and is proportional to the elapsed time from initiation of the ramp. The staircase voltage is used as the sweep signal for horizontal deflection. For sweep magnification, the full output voltage of the staircase generator is applied to the horizontal deflection circuit, but is attenuated in the feed-back to the comparator; the technique preserves not only accuracy, but also image brightness and resolution, and gives basic sweep speeds of 10 nsec/cm to

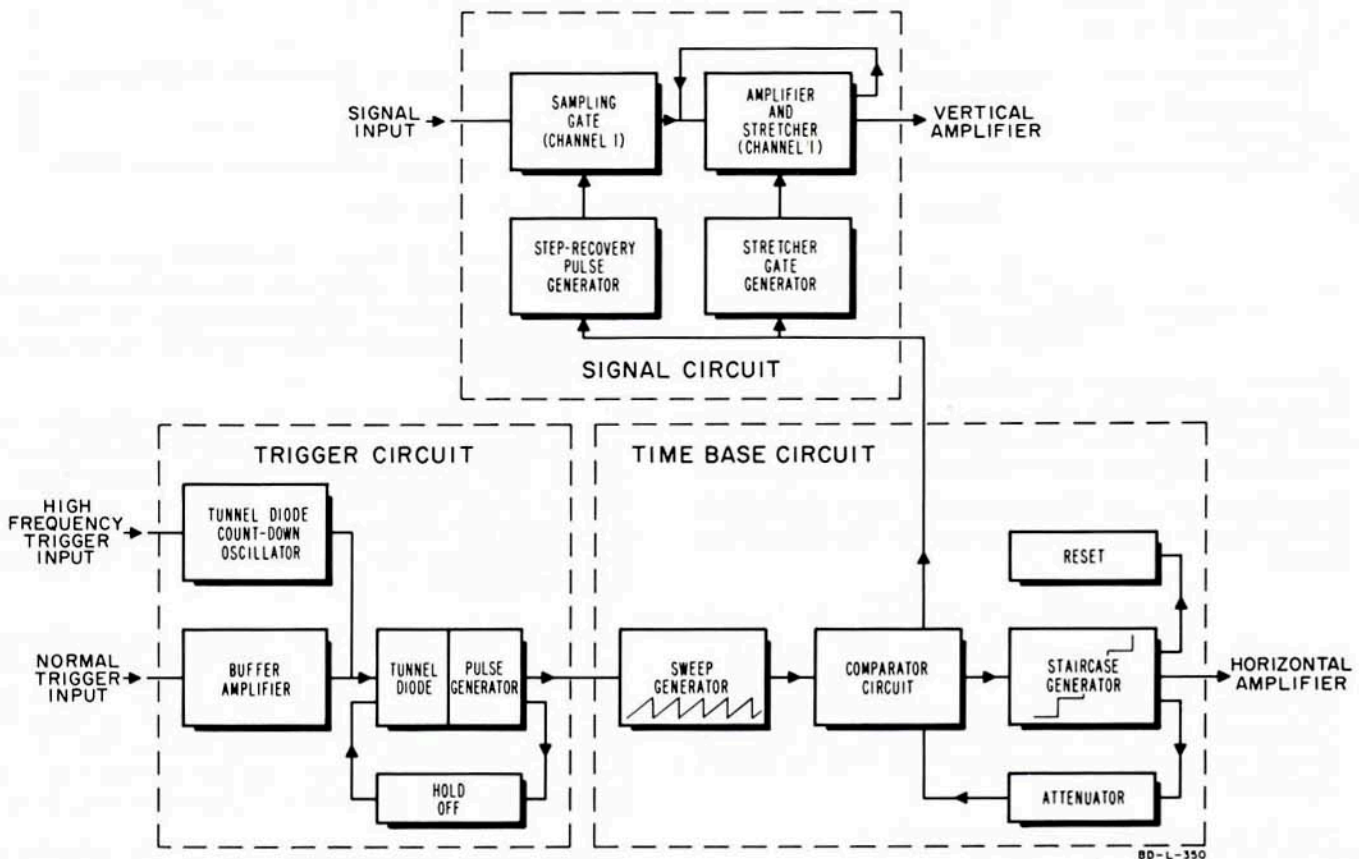

Figure 5. Sampling Oscilloscope Block Diagram

10 $\mu\text{sec}/\text{cm}$ with magnification to X100. When the staircase reaches a large enough level to deflect the cathode-ray beam full screen, it is automatically reset to start the next sweep by means of a conventional regenerative comparator circuit which discharges the staircase voltage. Sweep linearity depends upon that of the generated ramp along with delay uniformity in the comparator. Sweep speed is controlled by varying the capacitance, and speed by the dc starting level of the ramp. The staircase voltage is formed by coupling a pulse from the comparator through a diode to charge a capacitor that acts as a "bucket detector". For each sample, a small charge is placed on the capacitor, the amount determining the size of voltage steps from sample to sample and, thereby, image resolution.

Reducing the charge decreases the spacing of successive samples, but contemporaneously increases the time for scan completion. If scan time is too long, flicker may occur; however, a scan density control permits optimum performance between flicker and resolution; or, alternatively, a variable scan voltage can be applied manually through a potentiometer that serves also on the recorder output to permit direct signal plots with pen recorders.

SIGNAL CIRCUIT

Both the sampling act and the signal storage or stretching operation in the signal circuit are initiated by the time-base circuit comparator. Signal storage is actually a time stretching operation that stores the sampled signal during the interval between samplings. Two sampling channels, with their outputs alternately gated by a chopper provide the dual presentation: the sampling pulse-generator, common to each four-diode gating circuit, supplies balanced sub-nanosecond pulses for tight synchronization between the dual traces. Sampling is done directly at the input to the probes where these diodes are located and serves to maintain a constant impedance level. The impulse from the sampling pulse-generator, turning the gate on momentarily, charges the stray capacitance at the output of the sampling gate to a small fraction of the signal voltage, at the instant of sampling; this

change in stored value, after being applied to a cathode follower, is amplified in an ac amplifier, added to the stored level in the stretcher and then fed both to the vertical deflection circuits and back to the input circuit. The feedback system is adjusted to maintain the sampling gate output level to the input of the previous signal; thus, if the input amplitude is the same as that previously, no charge will be extracted from the input, no signal will be fed through the ac amplifier, no change will occur in the stored level of the capacitance, and consequently sampling efficiency will appear to be 100%. Using this method of balancing minimizes pedestal generation, input reaction, and loading from sampling; yet the gating circuit's dynamic range is maximized. The feedback system allows accurate control of sensitivity, nulling the "error" across the sampling gate by acting as an integrating servo. The display of modulated pulse trains will show the modulation dotted in at true value rather than being averaged out. Sample-to-sample under or overshoot may occur with variations in sampling efficiency, such as on warm-up. This change in dynamic response will not, however, affect sensitivity; any efficiency error causing forward gain of incorrect magnitude can be easily seen and immediately corrected with a "response" control.

CONCLUSION

Although the sampling method has been in use for a long time, its relatively recent application directly to oscilloscopes has brought about an instrument of great bandwidth and operating convenience for visual examination of very fast, repetitive waveforms (not necessarily periodic). The Hewlett-Packard instrument, just discussed, has many of these desired attributes in a highly refined degree: dual presentation, dc to 1 gc usable bandwidth, sensitivity to 3 mv/cm, fast sweeps, large display, excellent trace contrast, and high input impedance. Recent advances in the use of high speed switching diodes has provided an instrument capable not only of vastly improved sampling capability, but also with thoroughly reliable signal presentation for high frequencies.

References

1. Callendar, H. L., "An Alternating Cycle-Curve Recorder", The Electrician, pp 582-586, August 26, 1898.
2. Chaplin, G. B. B., "A Method of Designing Transistor Avalanche Circuits with Application to a Sensitive Transistor Oscilloscope", Digest of Technical Papers - 1958 Transistor and Solid-State Circuits Conference, University of Pennsylvania, Philadelphia, Pa., Feb. 20 & 21, 1958. Sponsored by I. R. E. and A. I. E. E.
3. Golding, E. W., Electrical Measurements and Measuring Instruments, Third Edition Revised. London: Sir Isaac Pitman and Sons, Ltd., 1942.
4. Hospitalier, E., "The Slow Registration of Rapid Phenomena by Strobographic Methods", The Electrical Engineer, pp 40-44, January 1, 1904.
5. Janssen, J. M. L. "An Experimental 'Stroboscopic' Oscilloscope for Frequencies Up to About 50 mc/s", Phillips Technical Review, Vol. 12, No. 2, pp 52-58, 1950 and Vol. 12, No. 3, pp 73-81, Sept., 1950.
6. Laws, F. A., Electrical Measurements, Second Edition. New York: McGraw-Hill Book Company, Inc., 1938.
7. McQueen, J. G., "The Monitoring of High-Speed Waveforms", Electronic Engineering, pp 436-441, October, 1952.
8. Reeves, R. J. D., "The Recording and Collocation of Waveforms", Electronic Engineering, Vol. 31, No. 373, pp 130-137, March, 1959 and Vol. 31, No. 374, pp 204-212, April, 1959.
9. Sugarman, R., "Sampling Oscilloscope for Statistically Varying Pulses", The Review of Scientific Instruments, Vol. 28, No. 11, pp 933-938, November, 1957.