

MICROWAVE SWITCHING

FROM SPDT TO

FULL ACCESS MATRIX

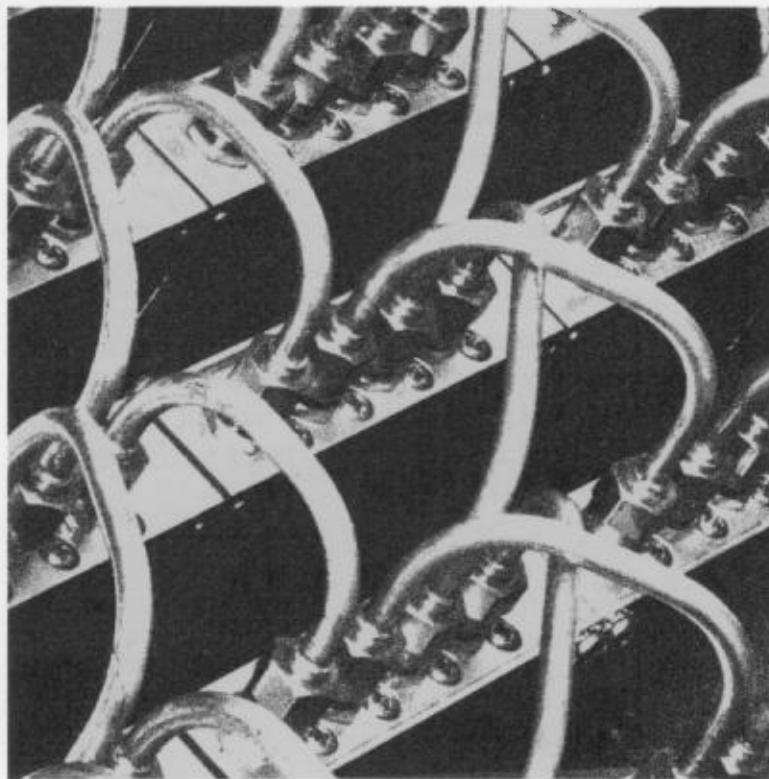

Application Note 332



MICROWAVE SWITCHING

FROM SPDT TO

FULL ACCESS MATRIX

This application note will review a number of RF & microwave switching configurations, from the simplest single-pole, double-throw switch through transfer switching to full-access matrix switching including matrix-test considerations. We hope that some of these application concepts may be of use to ATE and production test system designers who have to combine novel ideas with known switching concepts to meet their own local test requirements.

The note will also consider operating characteristics such as insertion loss, SWR, and isolation. It will cover only mechanical switch designs, not semi-conductor types. Diode models switch faster but generally exhibit too much loss and too little isolation for ATE purposes. Finally, since most switching is done for ATE purposes, some material is included on the HP 11713A Programmable Switch Driver.

W196

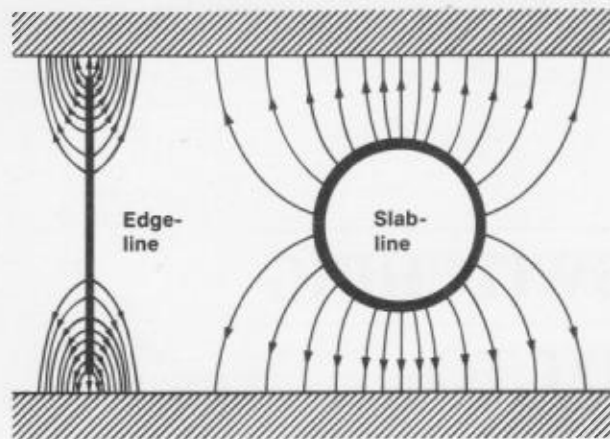

(a)

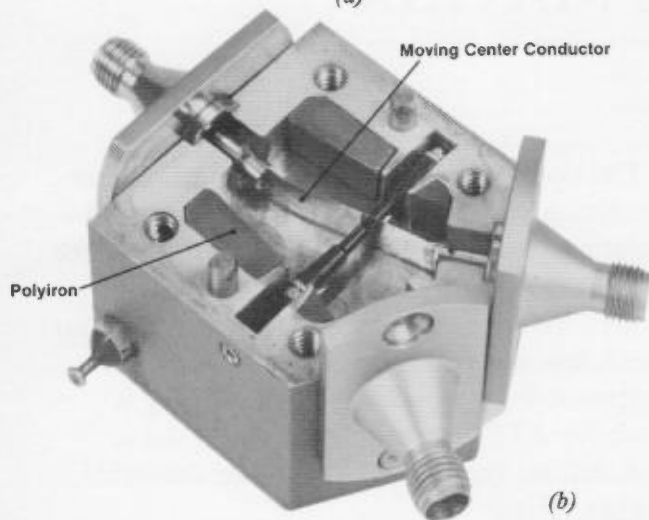

(b)

Figure 1. The "edge-line" transmission line concept (a) uses a flat center-conductor perpendicular to two ground planes which concentrates the field pattern at its edges. This allows a flexible "flipper" blade in the HP 8761A/B Coaxial Switch (b) to contact either output connector port.

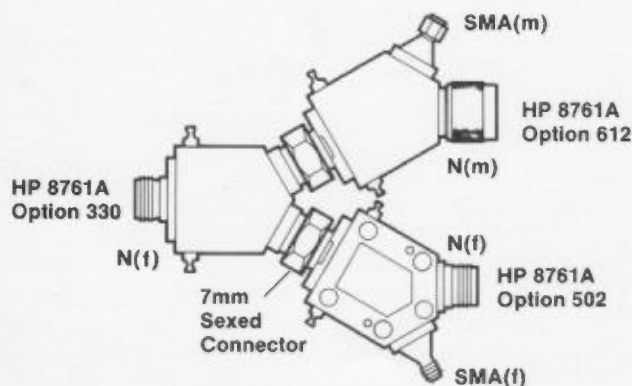

Figure 2. The HP 8761A/B Coaxial Switch offers a variety of connector options which allow switch "trees" to be configured. The 7 mm sexed inter-connection shown has particularly low SWR to 18 GHz.

SPDT

Single-pole, double-throw coaxial switches are the basic building block for switch trees and most microwave switching. The HP 8761A/B Coaxial Switch is the simplest of these since its design features the so-called "edge-line" [1][2] concept wherein a flat flexible center conductor moves between two coax output ports while suspended edge-on between two ground planes.

Figure 1(a) shows the field configuration of the edge-line concept as compared with the "slab-line" and an internal view of the switch, Figure 1(b), showing the "flipper" blade with the solenoid-activated push rods. Since the center conductor is a flat, thin strip, perpendicular to the slabs, the field is even more concentrated than with a round center conductor. This field concentration is desirable if the center conductor has a number of reasonably sharp turns, or if the center conductor is movable, as it must be in a switch. Keeping the fields concentrated near the center conductor edges also improves isolation between the two output ports in a switch.

The transitions from the coaxial ports to the special edge-lines are at the contacting areas. The flexible center conductor is made of beryllium copper held to close tolerances to keep the characteristic impedance constant along the line. It is heat treated to ensure long life. Polyiron blocks inside the switch suppress the higher order waveguide modes and improve isolation.

These HP 8761A/B Switches typically have SWR's less than 1.2 from dc to 18 GHz, insertion losses less than 0.5 dB, and isolations greater than 50 dB (at 12.4 GHz) between ports. One of their best features is that they are available with many different connector types as well as with an optional built-in 50 ohm termination on one port.

For measurement switching applications, repeatability of the switched connection is a key factor in minimizing measurement error. The excellent repeatability of these switches (typically 0.03 dB after one million switching operations) has been achieved by employing gold-plated contacts for the transmission line. The design feature of switching only the center conductor eliminates high-friction sliding contacts of the outer conductor, and results in long life and high repeatability.

The activating, or drive mechanism for the HP 8761A/B Switch is a magnetically latching solenoid. A 12 Vdc (Model A) or 24 Vdc (Model B) pulse 20 ms long or longer will operate the switch, the direction of switching depending on the polarity of the pulse. The switching voltage can be applied continuously if desired, but only pulses are required. This is important in systems where drive power requirements and heat must be minimized. Switching speed, including mechanical bounce, is typically 30 ms.

The mechanical design of the HP 8761A/B Switches makes it possible for one switch to “tree” off to two others as shown in Figure 2. When used in this configuration, the 7 mm male and female connector options give an interface with a particularly low SWR, which could be especially important if the signal path design includes five or six switches in series.

ALL-MATCHED PORTS

The HP 33311B/C Coaxial Switches (Figure 3) improve on the older HP 8761A/B in several important ways:

1. HP 33311C operates dc to 26.5 GHz.
2. Internal coil contacts are designed to disconnect the solenoids after the 30 ms switching operation (and magnetic latch) to minimize power supply drain and heat rise.
3. Isolation is 90 dB to 18 GHz (50 dB to 26.5 GHz).
4. A 5 Vdc option provides for easy compatibility to standard IC circuit designs.

The internal design of the HP 33311B/C still depends on the edge-line transmission line structure, and can be examined in Figure 4. The edge-line transmission line elements are four shorting bars each approximately 1-cm long attached to four sliding plastic plungers. The four plungers are arranged in two pairs and each pair works off a “see-saw” pivot arrangement so one shorting contact is down on its pair of coaxial posts when the opposing plunger is back up against the backstop polyiron signal absorber.

Figure 5 explains the circuit action diagrammatically. In the switch position shown, the common coax port C connects to port 1, while at the same time, port 2 connects to its internal 50 ohm termination. The termination uses a well-matched thin-film 50 ohm resistive element on sapphire, mounted over an air channel.

The basic approach to the design was to dimension the ground-planes surrounding the contact mechanism so they function as a waveguide beyond cut-off. The inherent rapid reduction in coupling with respect to distance between ports achieved by this construction allowed close spacing of the port connectors while still achieving at least 90 dB isolation between the common port and the “off” port up to 18 GHz (50 dB at 26.5 GHz.) This made short conductors possible, so insertion loss, even at high frequencies, is quite low.

The shorting-bar conductors are slightly bowed to provide a slight wiping action as the contact seats, achieving very good repeatability and long life. By the nature of edge-line construction, SWR is not appreciably affected by slight flexing of the conductors when making contact. The magnetic switching circuit uses two 24 Vdc coils (5 Vdc optional) and permanent-magnet latches. Separate dc coil contacts remove



Figure 3. HP 33311B/C Switches operate dc—18 GHz and 26.5 GHz respectively, with excellent isolation of 90 and 50 dB.

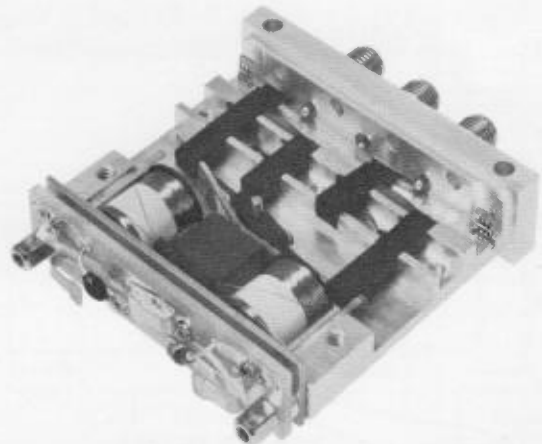

Figure 4. Internal view of HP 33311B Switch shows “see-saw” action of shorting bar plungers. Note the two internal 50-ohm terminations on sapphire at the edges.

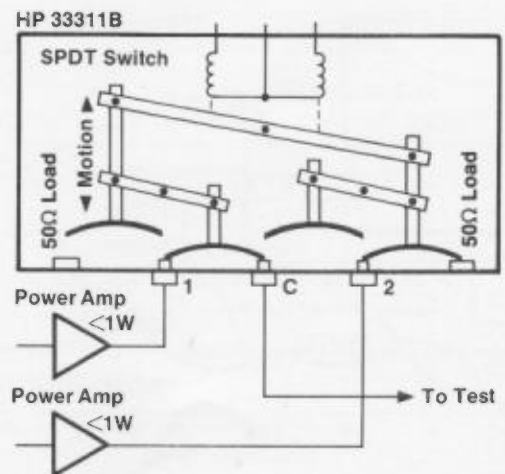

Figure 5. All-matched ports of HP 33311B/C Switch automatically terminate signals at the unused port.

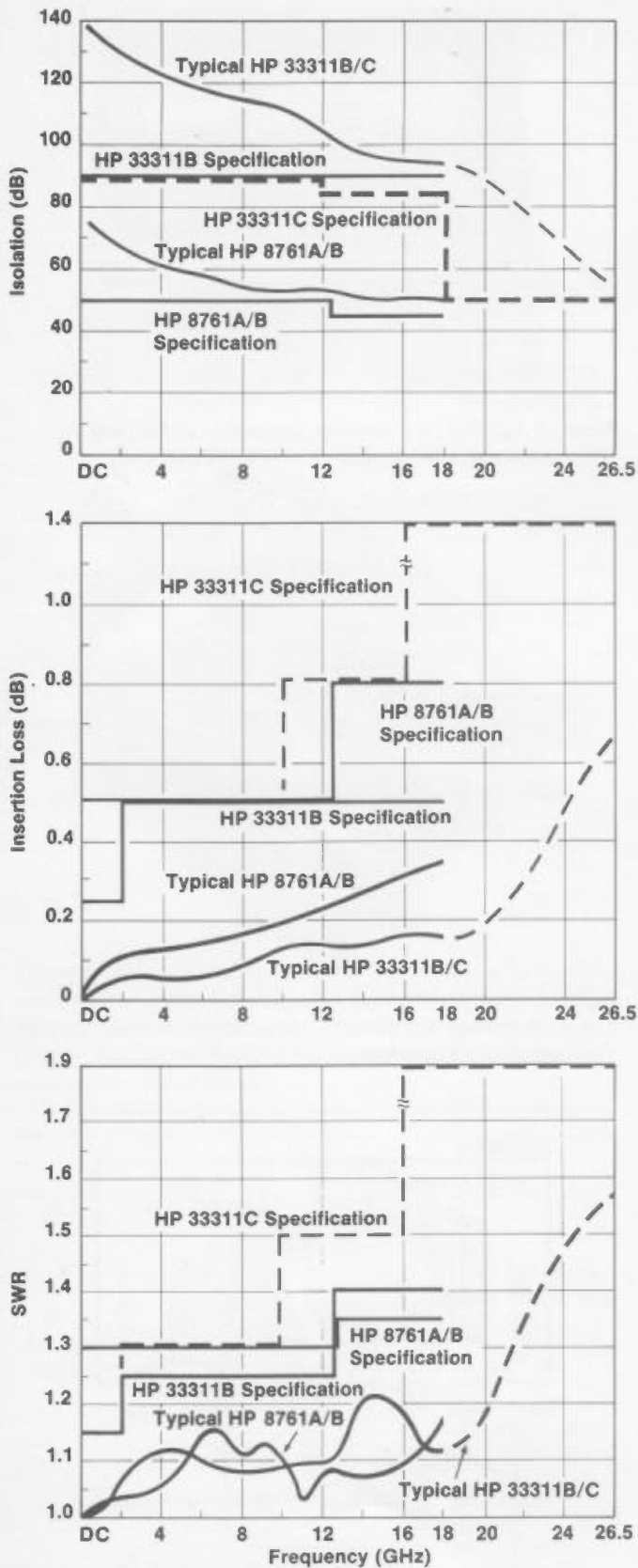

Figure 6. Electrical performance for HP SPDT coaxial switches showing specified and typical characteristics.

power from the activated coil as the switching action is completed so power is consumed only while the mechanism is switching (30 ms). Besides reducing power consumption and related heat buildup, this arrangement allows external circuits to sense the switch mechanical position since one of the two solenoid coils will be electrically "open" for each mechanical position.

Coaxial connectors for the HP 33311B Switch operating to 18 GHz are SMA female, while the HP 33311C Switch uses APC-3.5 female connectors for mode-free coverage dc to 26.5 GHz.

Figure 6 shows specified and typical performance for the SWR, insertion loss and the isolation characteristics of the three switches.

High isolation of the HP 33311B/C Switches assumes great importance in applications such as Figure 7 where two signal generators are switch-selected for a receiver test. The wide dynamic range of the receiver-under-test could detect switch leakage from the unused signal generator if the isolation wasn't high enough. (Naturally, the unused generator should normally be turned off.) The isolation performance will also turn out to be critical in matrix applications covered in a later section.

HP coaxial switches are obviously "break-before-make" type. Thus, during the switching interval, the switch exhibits an "open-circuit" condition momentarily. The designer should consider that action if a momentary reflection will affect the switched equipment.

ALL-MATCHED PORT SWITCHING FOR MEDIUM-POWER APPLICATIONS

For certain microwave signal switching applications, the switching "trees" require use of SPDT models with all-matched ports. A typical application might be where two active amplifiers or sources are combined through an SPDT switch, as shown in the previous Figure 5.

With a power rating of 1 watt for each internal termination, such a switch easily handles most instrumentation jobs, where signal generators, sweepers, and amplifier output powers are in the 10–100 mW range.

In other system test applications, such as VHF transceivers with 5–10 watt plus outputs, another solution must be sought. A 5-port version of the same HP 33311B SPDT Coaxial Switch serves this higher-power requirement.

Model HP 33311B-C05 Switch has both internal 50 ohm terminations removed and each replaced with another broadband SMA connector port. In operation then, 1 or 2 external medium-power terminations serve to absorb the system power, at the unused port. See Figure 8.

With a specified insertion loss of 0.5 dB at 18 GHz, a 10 watt average signal passing through the switch would cause approximately 1.1 watt heating of the switch frame which is well heat-sinked and tolerable.

Contact lifetime at medium powers is not specified because performance depends on power level, arcing, oxidation, etc. Thus it is preferable to make the switch action first, then turn on the power, rather than switch the medium power "hot". In that "cold" switch mode RF contacts will last much longer.

TRANSFER SWITCHING

For RF and microwave purposes, the term "transfer switch" is a switch configuration used to route a signal path from a straight-through condition to a path which passes through some arbitrary external device.

Traditional transfer switches look like the diagram of Figure 9. The configuration most likely derived from early waveguide models which functioned by rotating a center section 90 degrees. Coax models are similar in function but use a different structure.

Transfer switches also can be built using two separate SPDT coaxial switches connected together as shown in Figure 10. The setup works fine with two disadvantages: (1) it takes two separate switches at extra cost (although the doubled isolation resulting from two switches is higher); (2) the through-line signal path SWR is slightly degraded due to extra cabling and inter-connection.

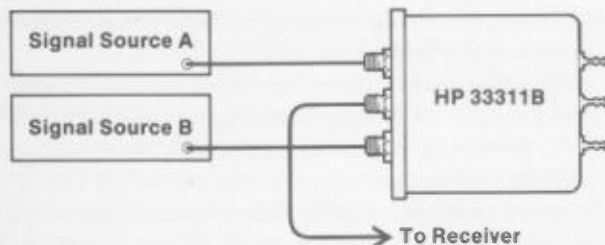

Figure 7. Greater-than-90 dB isolation of HP 33311B Switch is an important factor for measurements on the multiband receiver with wide dynamic range.

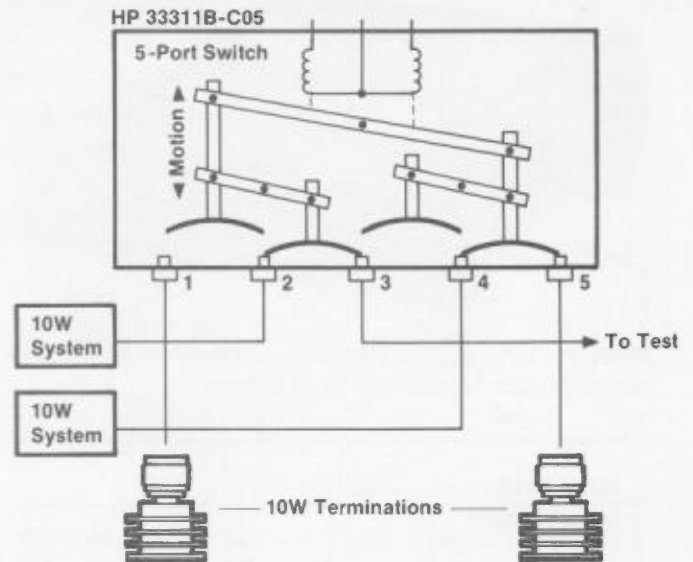

Figure 8. A 5-port version of the HP 33311B Switch applies unused medium-power signals to external power loads.

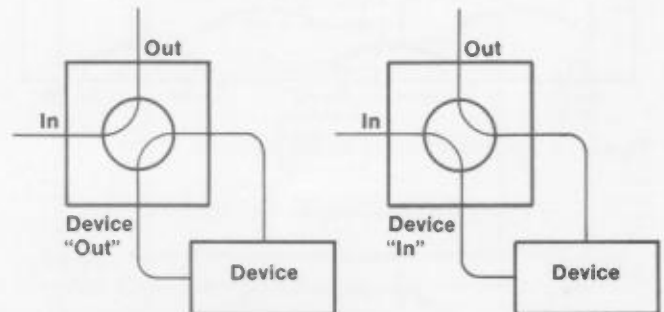

Figure 9. Traditional waveguide transfer switch had rotating center section which inserted device into signal line.

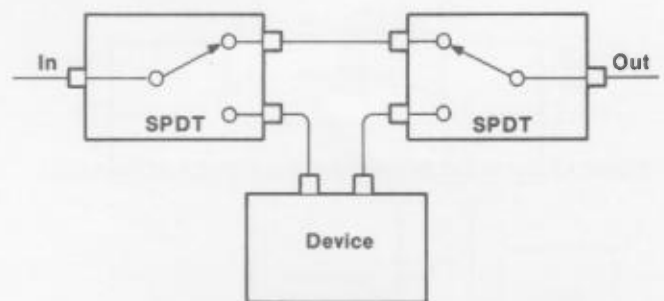

Figure 10. Two SPDT coaxial switches perform transfer function with high isolation.



Figure 11. HP 33311B-C05 5-port Coaxial Switch is compact and operates from dc—18 GHz with 90 dB isolation.

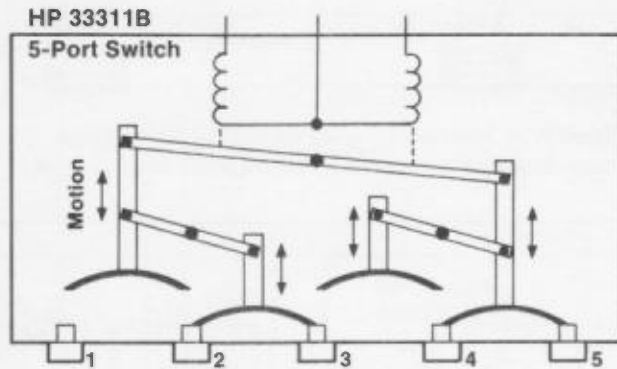

Figure 12. 5-port switch serves as transfer switch.

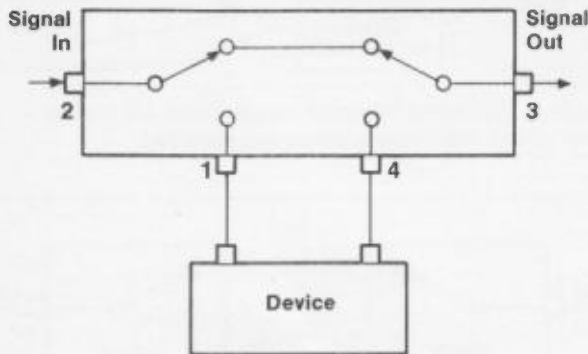

Figure 13. Equivalent switching function of switch of Figure 12.

The previously mentioned HP 33311B-C05 5-port switch (Figure 11) provides a single-switch solution. Examining the diagram of Figure 12, this configuration now can be envisioned as a four-port transfer switch functionally equivalent to Figure 13. (Port 5 is unused for this function.) (Note that the through connection is a single shorting bar and is internal.) And isolation of the HP 33311B-C05 remains at 90 dB to 18 GHz.

Transfer switch applications are numerous:

1. If a signal generator design requires a PIN pulser component in the signal line for pulsing but the 8–10 dB insertion loss degrades the CW power too much, a transfer switch can save about 7–9 dB of CW power by switching in the pulser for pulsed function and removing it for CW (higher power) function.

2. If the application requires switching in a fixed, specified amount of attenuation, say 36 dB, for some sort of calibration, just connect in 36 dB worth of coax pads between ports 1 and 4.

3. Sometimes microwave signal processing may need extra amplification, but not at all times. Connect in any amplifier to ports 1 and 4, and actuate the amplifier whenever required.

4. By connecting in a low-pass filter to ports 1 and 4, harmonic outputs of multi-octave microwave sources can be cleaned up. Use the straight-through path for the highest octave, then switch the LP filter for the lower octave to knock down second and higher harmonics.

5. To insert a passive harmonic generator into a signal line, wire it into ports 1 and 4. Likewise, a microwave detector could be switched in to give a video output when engaged.

6. Also consider inserting one of these coax components: mixer, PIN attenuator, step attenuator.

7. Switching in a device under test. Often a measurement test setup requires a transfer switch to insert a device under test (DUT) into a repetitive production setup. The test setup first runs the signal straight through to calibrate, then switches to the DUT for an insertion loss, gain or noise-figure test. By attaching two extender cables to ports 1 and 4, the transfer switch cuts in the zero-loss path. For example, a noise figure measuring system itself can be characterized for noise figure and signal sensitivity. Then, with the unknown DUT switched in and connected at the end of the extender cables, the overall noise figure can be analyzed and corrections can be computed for the second-stage noise figure.

A TYPICAL SYSTEM APPLICATION FOR TRANSFER SWITCHING

The HP 11729B Carrier Noise Test Set serves as a prominent example for a high-isolation transfer switching requirement. Essentially, a low-noise microwave downconverter, the HP 11729B gets its first local oscillator reference signal by power-multiplying an ultra-low-noise 640 MHz reference signal of the HP 8662A Synthesizer to obtain spectral "comb" lines out to 18 GHz.

The design then calls for a series of 7 fixed-tuned, band-pass filters to select a given spectral line on command. See Figure 14. Since it was critical to preserve rejection characteristics of each of the 7 filters, the chosen design used 7 transfer switches in series, each able to insert in or out of the "comb" signal line its own band-pass filter. The 90 dB isolation of the switch preserved the fidelity of each high-performance band-pass filter.

ANOTHER TRANSFER CONFIGURATION

Another adaptation of transfer switches involves the application where "parallel" insertion of filters is required. This contrasts to the "series" configuration just described in Figure 14.

In the "parallel" transfer configuration, two 1PnT (1-pole, n-throw) switches are used as shown in Figure 15. HP uses such a schematic in the HP 8673C/D Synthesized Generators to clean up signal purity in several frequency bands.

A primary limitation of this scheme occurs when any bandpass filter rejection specification exceeds the combined isolation of both 1PnT switches. In that case, signals being rejected by the operating bandpass filter (BP #2 in Figure 15) might couple to the "low-loss" passband of BP #3 in path 3 and thereby cause degraded and unwanted spurious signal performance.

At frequencies below 10 GHz, rejections of 2 times 50 dB are common (50 dB per switch), but at 26 GHz, isolations of as low as 2 times 30 dB would be possible, especially at sharp frequency resonances, so care must be used in setting the design configuration and then in specifying and qualifying the switches. A designer could consider using trees of SPDT switches to improve isolation.

ACTIVE DEVICE UNDER TEST

While most devices to be inserted in and out of a signal line are passive, some applications can be envisioned where an active device such as an amplifier is needed to boost the signal, for example.

In this case, Figure 16 shows how an external termination connected to port 5 serves to absorb signal power from the amplifier-under-test during the test condition where it is not inserted in the signal line. Or

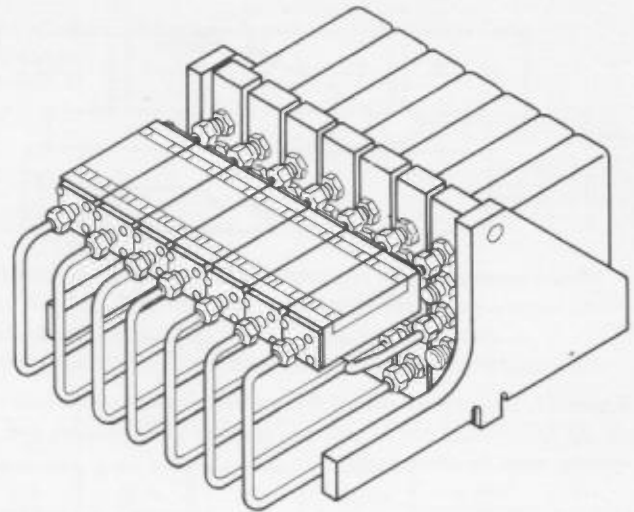

Figure 14. A bank of 7 HP 33311B-C05 Transfer Switches used in HP's 11729B Carrier Noise Test Set to select one of 7 bandpass filters on command.

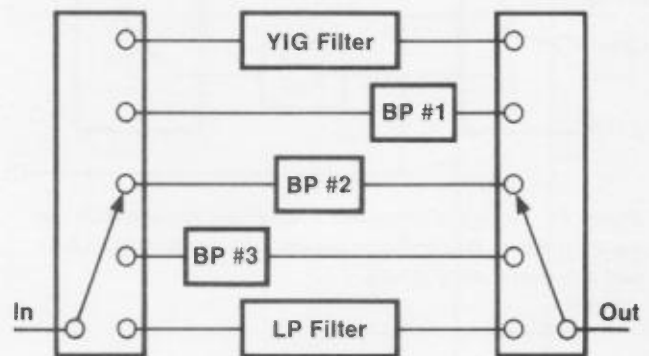

Figure 15. A pair of 1P5T selector switches can serve to "transfer" "n" components into a signal path.

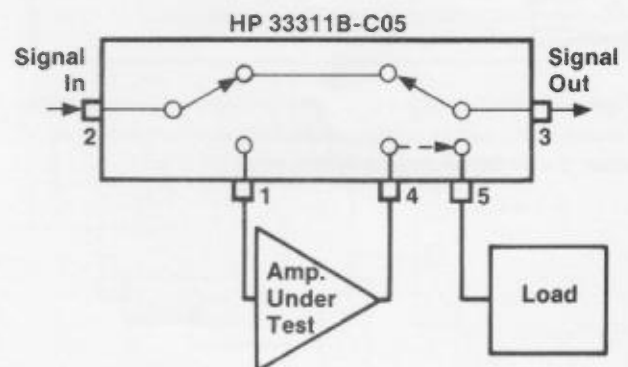

Figure 16. If the device under test is an active component like an amplifier, an external load connected at port 5 provides a load for the amplifier when not inserted in the signal line.

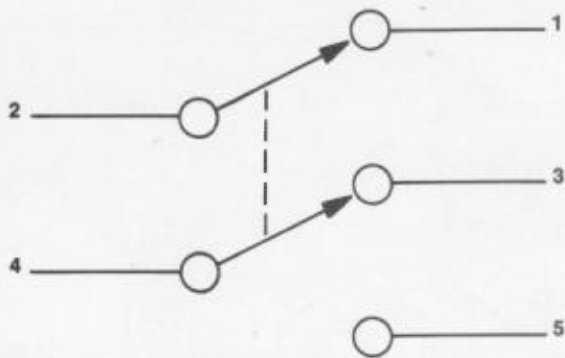

Figure 17. An alternate view of the switching function shows how the HP 33311B-C05 can be used as 2 separate SPST switches, one opening while the other closes.

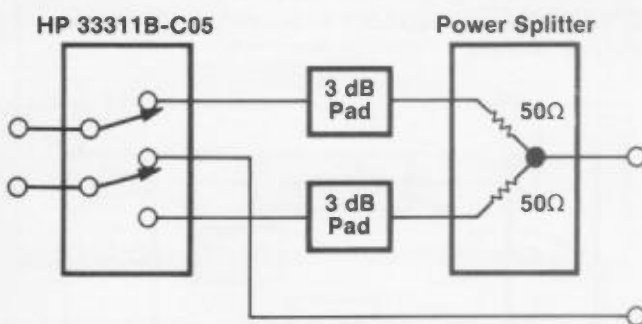

Figure 18. The 5-port switch and a broadband power splitter can provide a means to interchange two input lines to two output lines (one line loses 9 dB of signal).

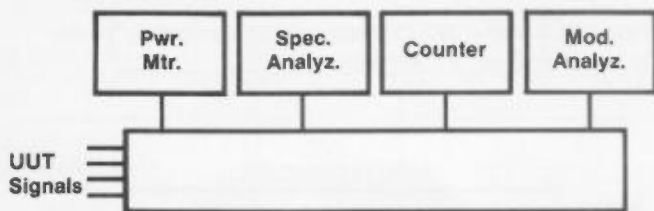

Figure 19. When a system is designed to analyze external signals, a switch matrix can be configured allowing the 4 test lines to be routed to a variety of analysis instruments.

there may be other applications where a test component needs a 50 ohm termination, to prevent an amplifier from oscillating by loading its input, perhaps. (Incidentally, the HP 33311B-C04 4-port Switch to be introduced on page 12 will do this same job with its own internal 50 ohm load with 1-watt rating.)

OTHER CONFIGURATIONS FOR 5-PORT SWITCHES

From a slightly different view point, the internal structure of the HP 33311B-C05 Switch can be visualized as the switching function of Figure 17. If one ignores port 3, it can be used as two separate but mechanically-linked SPST switches, one closing while the other opens. The excellent 90 dB isolation keeps the two signal paths well isolated. A 50 ohm termination could be added to port 3 to load out a switched signal from one or both ports 2 and 4.

Or maybe there's an application for two separate but overlapped SPDT Switches with one unusual common terminal (port 3).

SIGNAL INVERSION

Finally, Figure 18 shows a configuration for the HP 33311B-C05 5-port Switch used in conjunction with a broadband power splitter to serve as a signal inverter whereby 2 input coax lines are inverted on command to 2 output lines. The penalty is the 9 dB path loss from the power splitter (combiner) plus 3 dB pads. But for any particular application, that path loss in one channel may be quite acceptable. The offsetting advantage of the HP 33311B-C05 is its 90 dB signal isolation vs. typical 50-60 dB specs for more traditional transfer/inversion switches. The extra 3 dB pads are used to provide extra isolation since in either switch condition, one microwave path ends in an open circuit, thereby causing approximately 1 dB of power "ripple" interaction on the opposite line. Depending on the application, this may or may not be tolerable.

MATRIX SWITCHING

In the configuration and design of microwave automatic test equipment, the designer usually wants to provide a highly flexible signal-switching arrangement. This will involve some sort of matrix switch in which multiple input lines can be applied to various output lines.

For example, if the ATE system is intended to analyze signals from a unit-under-test (UUT), the matrix switch could be configured as in Figure 19, where three or four UUT lines could be routed to a variety of signal analysis instruments. Ideally, each of the four UUT lines could be routed to any of the measuring instruments concurrently.

An obvious alternative to switching might be to use power splitters or to sample signals off directional couplers. But then measuring sensitivity would suffer. Further, all UUT signal inputs could not be sampled and split to all instruments without signal interactions.

The opposite matrix function might involve the routing of various system stimulus instruments out to selected units under test (UUT) (see Figure 20).

Designing such switching matrices is not a trivial job because signal quality, isolation, path loss, and SWR must be considered, especially when signals up to 18 and 26 GHz must be routed.

The simplest matrix switch merely combines several standard 1PnT (1-Pole, n-Throw) selector switches as shown in Figure 21. In this case, two 1P4T switches form a 4 x 4 matrix capability allowing any of four test system instruments to be automatically gated to any one of four units-under-test.

Working against the simplicity of that matrix are two disadvantages; (1) only a single channel connection (single-channel access) can be activated at one time, forcing measurements into a sequential and more time-consuming pattern, and (2) the path isolation of 1PnT coaxial switches is often specified at 50 to 60 dB and may not be high enough to prevent feedthrough and cross-talk, especially if wide dynamic ranges are involved.

For example, the signal generator #1 of Figure 21 may have signals up to 100 mW (+20 dBm) while the spectrum analyzer has sensitivities down to -70 dBm. Switch isolations of 60 dB would then require careful attention in the programming to be sure all unused signal sources and emitting UUT's were gated off to prevent such interactions.

Building up a switching tree from high-isolation SPDT switches offers one solution to the isolation problem. For example, each HP 33311B Switch in Figure 22 has 90 dB of isolation, effectively giving a 4 x 4 matrix with substantial isolation between system instruments as well as the unused units-under-test. The matrix is still a single-channel access.

In such configurations the designer can use his or her ingenuity in choosing ports for the various instruments. For example, the isolation between ports 1 & 2 is 90 dB, but the isolation between ports 1 & 4 has one additional 90 dB switch in between port 1 and port 4.

Two additional advantages come from using HP 33311B Coaxial Switches with all-matched ports: (1) the internal 50 ohm load can terminate signals such as the signal generator at port #1 of Figure 22, and (2) any unused coaxial connecting cables (like the asterisked ones in Figure 22) are "loaded out" with 50 ohm terminations on the unused port of another HP 33311B Switch.

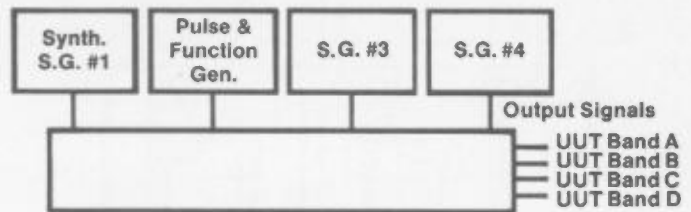

Figure 20. Various signal simulators can address four units under test (UUTs). Designing such switching matrices is not a trivial job since signal quality, isolation, path loss, and SWR must be considered, especially when routing signals of 18 to 26 GHz.

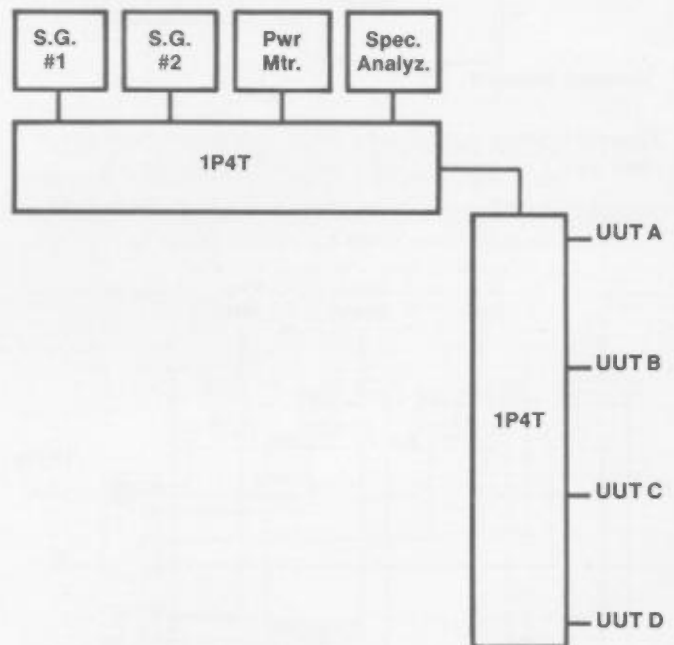
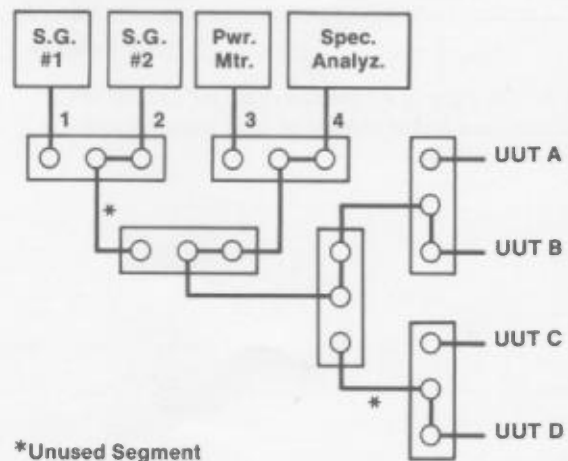

Figure 21. Two 1P4T selector switches form a single-channel 4 x 4 matrix.



*Unused Segment

Figure 22. HP 33311B Switches provide better signal isolation when used in matrix "trees". This 4 x 4 single channel matrix shows a 4B connection.

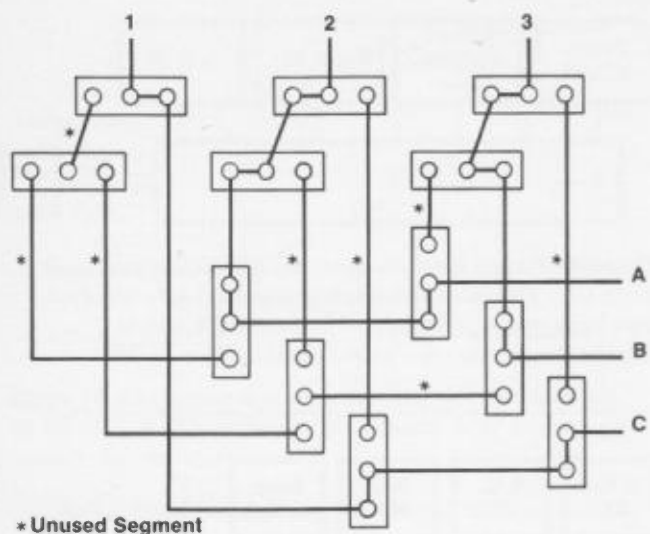

Figure 23. Simple matrices using SPDT Switches are fairly easy to build. This 3 x 3 matrix of SPDT coax switches requires 12.

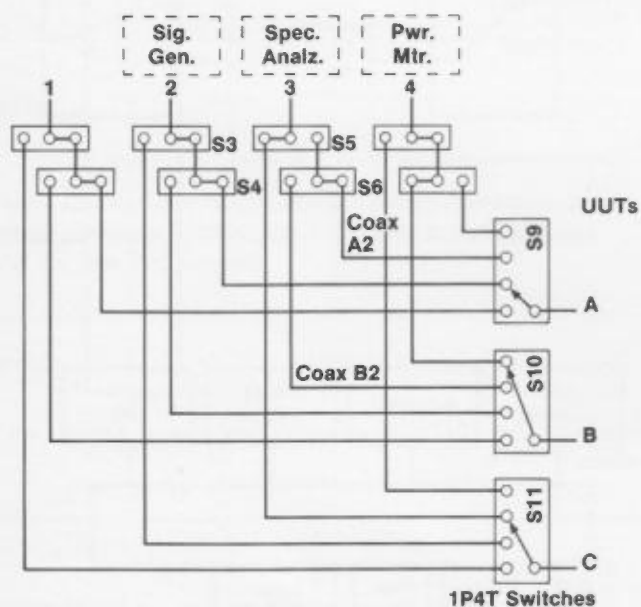

Figure 24. The extra 90 dB isolation of the HP 33311B SPDT Switches enhances limited isolation of 1P4T selector switches in multi-channel matrices.

Specifically, the feature of internal 50 ohm loads is important since each unused segment of coax transmission line — if unterminated on one end or the other — may resonate at a frequency where it is one-half wavelength long, and at all higher frequency multiples. A 10-cm length, for example, in coax with dielectric constant of 2 would be 0.5λ at 3000 MHz. These resonances might suck out signal power at high Q at specific frequencies.

This can be quite important when designing switch trees up to 26 GHz where switch isolations drop to 50 dB (the HP 33311C Switch operates dc-26 GHz). Such leakage, though small, might otherwise excite resonances which would selectively draw down power.

FULL ACCESS MATRICES

To most ATE designers, operational time on a large expensive test system dictates multipath testing be run concurrently so that all stimulus and measuring equipment is used to its maximum capability. Furthermore, several channels may need to be operational together, for example, to activate a stimulus channel and measurement channel simultaneously.

This requires a so-called “full-access” matrix, meaning that there can be multiple active channels through the matrix concurrently. For example, in a 3 x 5 matrix, there would be three active arbitrary signal paths through the matrix at one time.

Simple matrices can be built with SPDT switches as shown in Figure 23. The sample shown is 3 x 3 (3 input lines, 3 output lines.)

If the matrix is (n x m) the number of such SPDT switches required is $(n-1)m + (m-1)n$. In Figure 23 a total of 12 switches is needed. Switches can be laid out physically to provide a convenient clustering. HP 33311B Switches can be mounted upright and connected with U-shaped 0.141 semi-rigid coax and SMA connectors.

For small and simple matrices, the modular advantage of SPDT switches in terms of serviceability is hard to beat. In particular, this matrix architecture is good for designs going to 26 GHz since the isolation offered by multiple switches (50 dB each for the HP 33311C) helps prevent signal interactions. On the other hand insertion loss increases because the signal must traverse multiple switches.

Notice that in Figure 23 (drawn with connections for 1C, 2A and 3B), there are many unused coax segments shown with asterisks, but every one of them ends in a switch with an internal 50 ohm load connected.

A COMBINATION MATRIX

The isolation performance of 1PnT selector switches can be a significant limitation to instrument matrix applications as in Figure 21 since signals on one port may feed across and interfere with others on adjacent

ports. Whether such performance is satisfactory depends on the particular application. For example, if signals of widely-differing dynamic range are handled (60 dB plus), such selectors may not be adequate.

For the single-active-channel application of Figure 21, 50-60 dB of isolation may be quite adequate since instruments or UUT modules are often de-activated during a measurement sequence at another port.

The isolation and cross-talk becomes much more significant when designing a matrix with multiple active channels. By using SPDT switches for half the matrix, the extra-high isolation offered by the HP 33311B Switch can enhance the effective isolation of 1PnT switches as shown by the schematic diagram of a 4 x 3 matrix in Figure 24.

For example, if a high-power UUT signal was applied to UUT port B in Figure 24, the intended path to system port 4 (perhaps a power meter) is shown by the SPDT connections shown. Now, assuming a 50 dB isolation in selector switch S10, a signal 50 dB smaller also appears on connection coax B2. But since it gets rejected by the 90 dB isolation of S6, it cannot get through to port 3 where the spectrum analyzer might be making a -70 dBm measurement concurrently on UUT port C through switches S5 and S11.

Likewise, a +10 dBm signal generator signal at port 2 will be -80 dBm at switches S10 and S11 so it won't interfere with UUT ports B & C. But since it exits through UUT port A, it also appears on connection coax A2 at -40 dBm. But SPDT switch S5 and its 90 dB isolation prevents it from entering the spectrum analyzer at port 3.

This type of isolation analysis needs to be performed during the matrix design process, especially when exceptionally wide dynamic ranges of signals are present in stimulus and response or at the UUT equipment.

A PREFERRED ARCHITECTURE — INTERSECTION SWITCHING

As matrices get larger, the number of SPDT switches begins to increase rapidly, and another alternative which uses fewer switches and interconnecting cables becomes more attractive. It uses the "intersection" switching architecture^[3]. To review a low frequency matrix, see Figure 25. This "crossbar" type simply connects the appropriate horizontal and vertical lines.

At microwave frequencies, life gets tougher since all those parallel wiring arrangements to the intersection switches would require tee connections, unterminated transmission line stubs of various lengths, and totally unacceptable mismatches.

For microwave frequencies the ideal matrix intersection switching action would be as shown in Figure 26. In this configuration, the unused segments beyond the active intersection are switched out and unused.

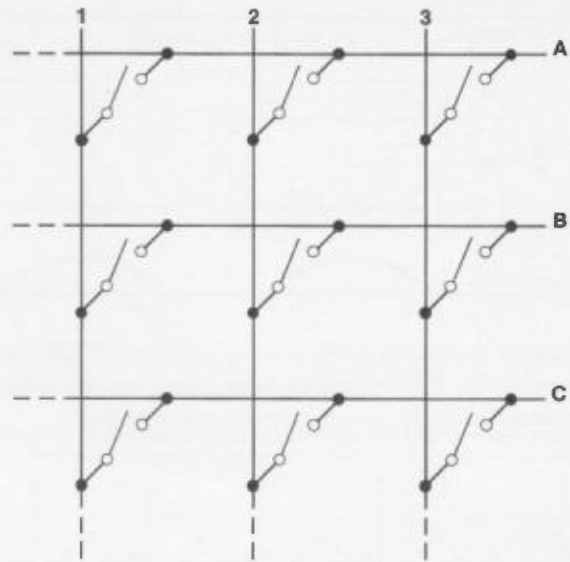

Figure 25. At low frequencies, this ideal matrix switch works fine. However, at microwave frequencies all the parallel wiring arrangements require tee-connections, unterminated transmission line stubs of various lengths, and totally unacceptable mismatches.

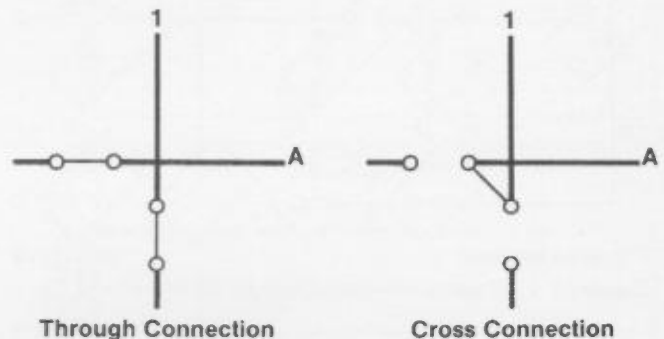

Figure 26. "Ideal" microwave matrix intersection switching action provides high-isolation for through connection and low loss for cross connection.

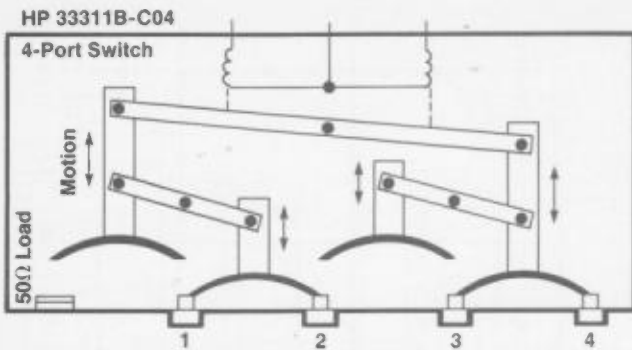

Figure 27. Internal switching action of typical 4-port matrix intersection switch. 50Ω termination helps swamp out any half-wave resonances caused by external unused coaxial segments.

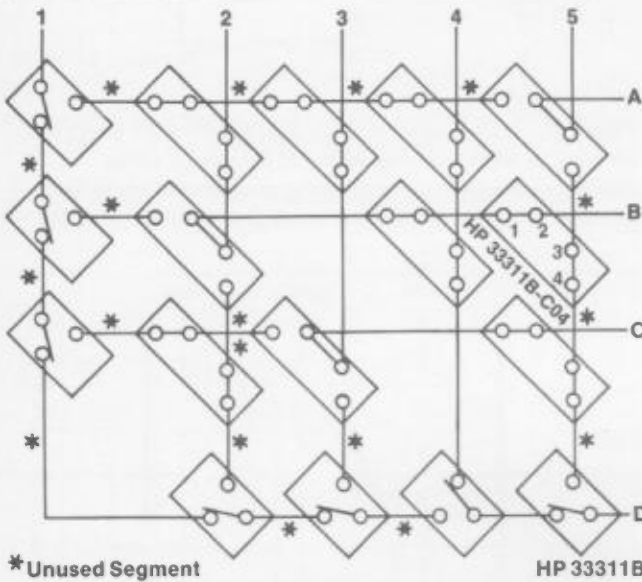

Figure 28. 5 x 4 matrix with connections for 2B, 3C, 4D and 5A.

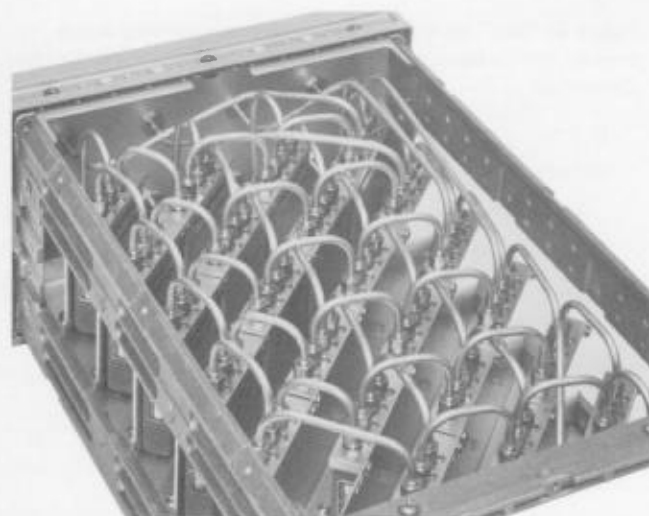

Figure 29. Typical layout for 4 x 6 matrix with 4-port intersection switches mounted vertically showing semi-rigid coax interconnections.

Interestingly, a modification of the HP 33311B Switch performs just that action. One of the internal 50 ohm terminations is removed and a fourth coax connector added for the circuit configuration of Figure 27. In one position it provides a "through" connection (1 to 2 and 3 to 4) and in the other position cross-connects (2 to 3). This modified switch is called HP 33311B-C04.

Note that now port 1 gets internally terminated with 50 ohms in the cross connection mode which will turn out to be important.

This switch can be used to build a 5 x 4 matrix, good from dc to 18 GHz (Figure 28). Notice that the 4-port HP 33311B-C04 Switch is used at all intersections except at the left end and bottom where only SPDT switches are needed. The matrix of Figure 28 is shown switched for the following connection: 2B, 3C, 4D, and 5A.

Each 4-port switch provides a "cross-bar" switching action. It either connects both crossing lines with low insertion loss or passes both signal lines through the intersection with 90 dB isolation from dc to 18 GHz. Figure 27 shows the internal "see-saw" structure of the HP 33311B-C04 4-port Switch with two of the shorting bars down on coaxial pins 1 and 2 and also 3 and 4. The other two shorting bars are retracted.

The switches themselves can be interconnected externally with U-shaped segments of 0.141 semi-rigid coax cable. By mounting the coax switches vertical to a panel, an interconnection pattern like Figure 29 results. That picture shows a 4 x 6 matrix.

Physically, the coax switches provide a convenient layout cluster. For example, the layout of Figure 29 is made to assure that many interconnecting lengths of coax are identical and has been oriented to make shorter cable runs to and from the panel.

A useful feature of the HP 33311B-C04 Intersection Switch is the internally switchable 50 ohm termination which "loads out" any short, unused external coaxial line segments to prevent half-wave resonances.

Notice especially that each and every unused line of Figure 28 (shown with an asterisk) ends up in a 50 ohm termination, either in connector number 1 of an HP 33311B-C04 Switch or in one of the internal 50 ohm terminations in the HP 33311B SPDT Switches on the borders. In addition, unused signal lines are terminated; for example, if unused matrix input at port 1 would have a signal on it, the signal would end up in the 50 ohm termination of the SPDT switch at intersection 4D.

Notice that any unneeded intersection can be bypassed by just leaving out the switch (3B and 4C in Figure 28). The designer can examine intended usage and determine which system instruments will never connect to certain UUT's and eliminate those intersection switches.

Now let's look at the economy of the 5 x 4 intersection matrix of Figure 28. (Putting intersections 3B and 4C back in).

12 ea. HP 33311B-C04 at \$735 = \$8,820 (U.S. prices)

7 ea. HP 33311B SPDT at \$570 = \$3,990

\$12,810 Total

To use the SPDT-switch-only technique of Figure 23 would require $(5-1)4 + (4-1)5 = 31$ switches.

31 ea. HP 33311B SPDT at \$570 = \$17,670 Total

So the intersection switch architecture usually gives the lowest cost. And usually it involves the lowest number of switch traverses, thus less insertion loss.

By connecting the matrix of Figure 28 as shown in Figure 30, system stimulus instruments such as signal generators may be routed to the unit under test (UUT), as shown by the signal path arrows. Likewise, signals from the UUT may be routed to measuring instruments, for example a power meter, spectrum analyzer, or counter.

If you study the action of any given HP 33311B-C04 Intersection Switch in Figure 28, you can see they are in a proper orientation to allow the signals to flow from the top of the diagram downwards and to the right side as shown by the flow arrows. Any other orientation of an intersection switch sends signals in the wrong flow direction.

The graphs of Figure 31 show microwave signal performance. Signal characteristics of insertion loss and SWR were measured for a test path consisting of a 6-switch chain. In the 5x4 matrix of Figure 28, the longest traverse is 7 switches (1-D) and the shortest, of course, is 1 switch (5-A). The 6-switch measurement of Figure 31 shows a maximum insertion loss of about 2 dB at 18 GHz. The SWR curve, likewise, shows fairly well-behaved reflections with very little "regular-irregularity" occurring due to equal spacing of connecting cable segments.

Incidentally, the higher path loss of the longer paths doesn't necessarily have to be a severe drawback, since the designer often has some control over which stimulus signal or UUT lines go where. For example, lower frequency signal lines could be routed through paths 1, 2, C and D, while the 18 GHz signals could be reserved for 4, 5, A and B. In this way, signals for the higher frequencies (18 GHz) may only have to traverse path lengths of up to four switches.

EXPANDING THE MATRIX

Because of the modular nature of the intersection switch, the size of the matrix is quite arbitrary, limited mostly by the allowable path loss of the longest paths. The other criterion to be considered is the maximum number of concurrent signal paths needed for the intended use of the interface. As mentioned, four concurrent signal paths may be used by the matrix of Figure 28.

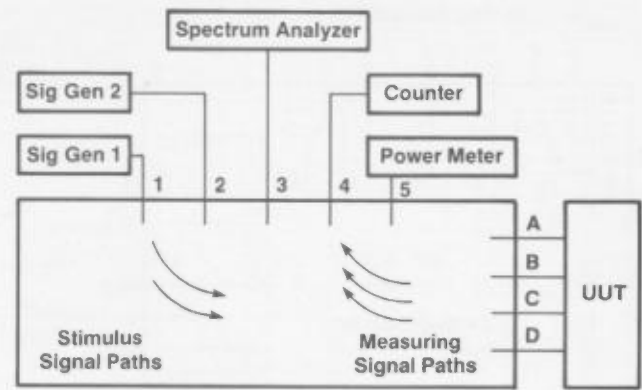

Figure 30. Signal flow in matrix used for interfacing units under test.

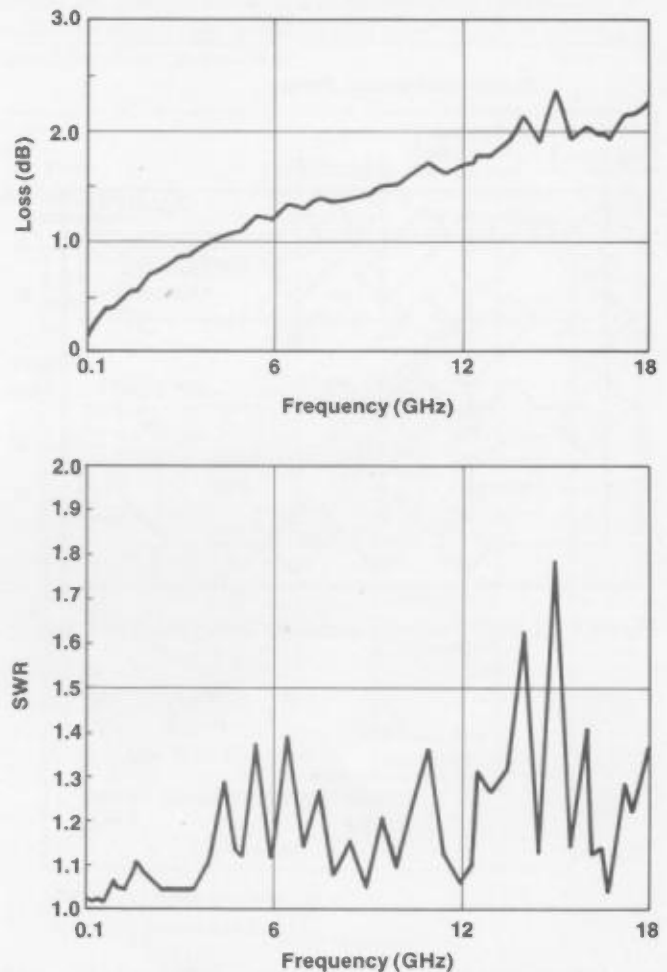

Figure 31. Typical performance of six HP 33311B-C04 4-port switches connected in series.

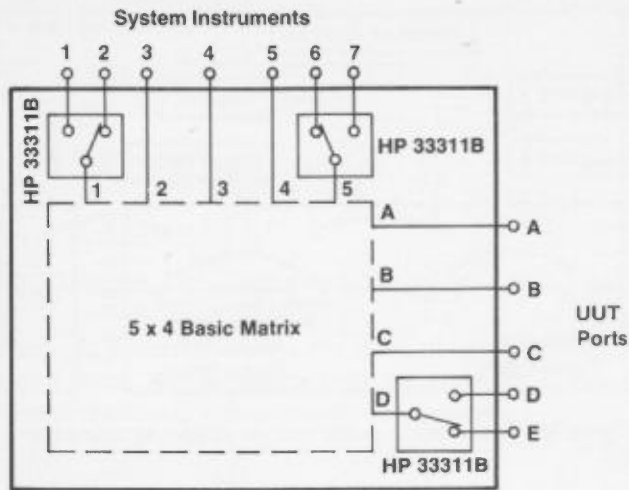

Figure 32. A 5 x 4 matrix expanded to 7 x 5.

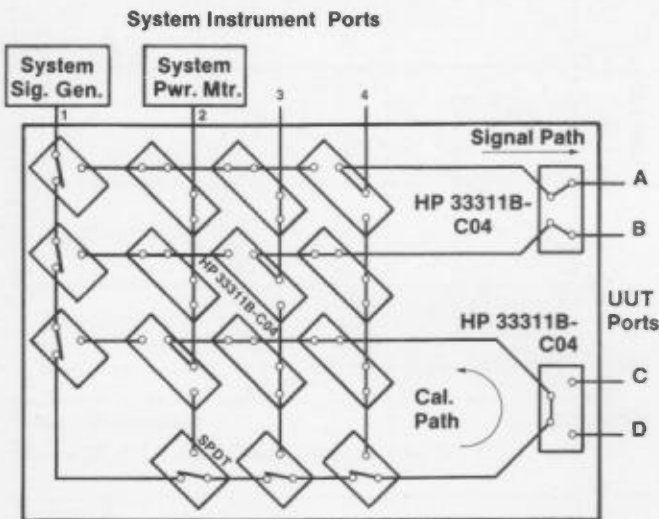

Figure 33. A simple automatic method for testing switch path loss.

The schematic of Figure 32 shows a very straightforward expansion of the matrix to handle more signal lines. Three additional SPDT switches have been used to expand the matrix to a 7x5 unit. Of course, the basic limitation of four concurrent signal paths still exists, but the designer is now able to choose which of the system ports (1-7) goes to which instrument and likewise for the UUT ports. Thus, lower usage instruments might be "switch-treed" off to a single basic matrix port. The designer's ingenuity is the watchword here, since the designer is the only one who knows the true switching requirements.

SWITCH MATRIX CALIBRATION

System interface calibration takes many forms, and has had reams of reports and many ATE workshops devoted to it. Sometimes, roll-up standards are brought up to the interface panel. For example, a power meter can check system stimulus power at the UUT panel. For others, test signals must be calibrated down inside the UUT interface adapter.

For the matrix of Figure 28, coax "shorting segments" might manually connect ports A to B and C to D externally. In this way, system stimulus instruments (generators) can be routed backwards into system detector instruments like power meters or counters. Path losses may be pre-measured and stored in correction look-up tables. Both the "outbound" and "inbound" path loss must be considered.

There is an automatic way to do this shorting technique. Figure 33 shows how several of the HP 33311B-C04 switches provide an automatic "shorting bar" between ports A and B or C and D. If the system signal generator were connected to port 1, and the system power meter to port 2, most of the intersection switch paths could be checked. For example, Figure 33 shows the path 1 system signal generator routed toward UUT port D, turned back onto path C, and thereby back to port 2 to be measured by the system power meter. Likewise, ports A and B could be shorted to test those paths also.

In a similar fashion, system ports 3, 4, etc., can be checked by routing either the port 1 signal generator to detection type system instruments on those ports or using the port 2 system power meter to measure other system stimulus instruments.

A NOVEL PATH CHECK CONFIGURATION

The ultimate interface check is to attach a perfect power meter or a perfect signal generator right at the external UUT test port and run a calibration data procedure on the system stimulus or detector instruments, respectively, right on the UUT panel. Such a hookup obviously lacks the advantage of being automatic.

The following material describes a way to automatically switch signals from right *behind* the UUT interface panel to a calibration self-test path rank of switches. Figure 34 shows the detail of such a self-test path.

First, notice that the position of the HP 33311B-C04 Switches in the calibration self-test path causes signals normally headed outwards to the UUT to be directed upwards to and from the calibrating power meter or signal generator. The main advantage to this configuration is that it puts a fairly well-characterized power meter or calibrating signal generator right up *behind* the UUT panel, on each UUT port as programmed. In Figure 34, the system stimulus is being routed to the calibration power meter through paths 1 and B.

A second advantage is that since the system calibration would be done infrequently, such as daily, the switches in the calibration vertical rank would not be expected to deteriorate very rapidly and would thus maintain quite repeatable switch and path loss for extended periods.

Some systems may not have a power meter or a calibration-quality generator in their racked configuration. So the test path connector could be on the front panel and use a roll-up generator and power meter during the calibration sequence.

If the system itself is configured with a calibration-quality generator and power meter, can they be switched in and out for the calibration function? The answer is yes. Figure 35 shows a novel switch hookup which performs a number of functions with a minimum number of switch traverses and associated losses. An HP 33311B-C05 5-port Switch is used (S1) in addition to the HP 33311B-C04 4-port (S2) and an SPDT version (S3).

The first feature is that the power meter remote sensor would be mounted either right at the internal rack panel or as shown in Figure 35, just inside the interface box. In addition, coax switch S3 can automatically switch in the 50 MHz, 1 mW, 1.2% accuracy, reference oscillator to be used for power meter reference. For the power meter, normally mounted at some distance from the interface panel and matrix switch, this puts a traceable 1 mW power reference close to where system power exits to the UUT.

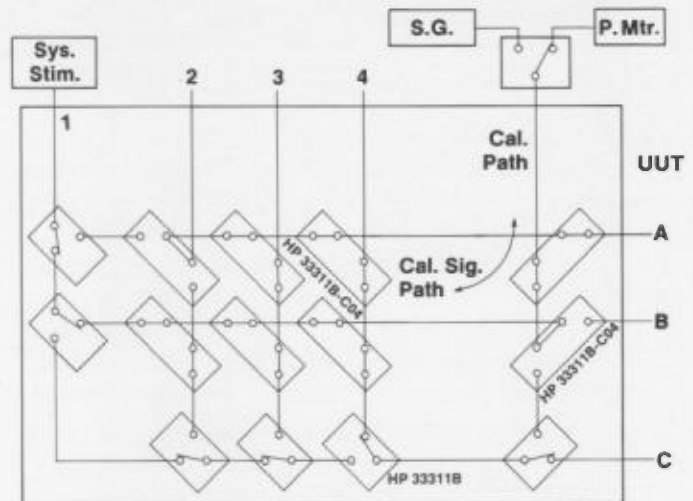
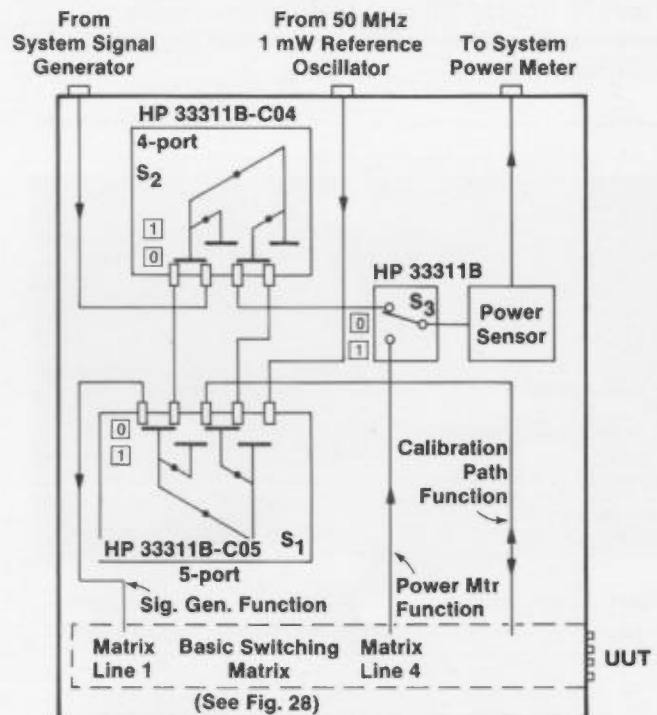

Figure 34. A special switch rank (calibration path) can inject calibration signals right behind the UUT panel or pull out stimulus signals for the test power meter.



Switches shown in state .
Opposite position state .

Figure 35. This switching allows the system signal generator and power meter to also be used for calibration.

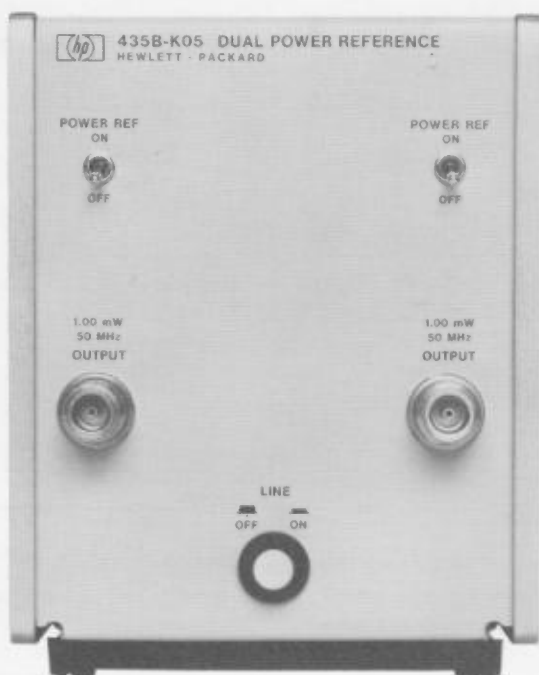

Figure 36. HP 435B-K05 Dual-Power Reference Oscillator provides highly accurate 1 mW power traceability for system calibration.



Figure 37. HP 11713A Attenuator/Switch Driver supplies drive power for up to 10 HP 33311B/C Switches under HP-IB program control.

The new HP 438A Dual-Sensor Power Meter contains a 50 MHz reference oscillator which could be coaxial cabled to the 50 MHz input jack. Or, the HP 435B-K05 Dual-Power Reference Oscillator (Figure 36) is a separate instrument containing two separate 50 MHz power reference oscillators for redundancy and measurement assurance. It could be mounted near the interface panel. Let's examine the switching functions of Figure 35 by looking at the various desired functions of interface. In the following table, the switch positions as shown in Figure 35 are designated state $\bar{0}$. The opposite switch position is noted as state $\bar{1}$. (-) is a don't care position.

FUNCTION	SWITCH STATE		
	Switch S1	Switch S2	Switch S3
1. Signal generator for system use; power sensor for system use.	0	0	1
2. Sensor calibration using 50 MHz power reference oscillator.	1	0	0
3. Signal generator output calibrated vs. frequency, using pre-calibrated power sensor.	—	1	0
4. Signal generator to calibration path; power sensor for system use.	1	0	1
5. Signal generator for system use; power sensor to system calibration path.	0	0	0

It will be noted that for most functions, the desired signal only traverses 2 or 3 switches. For example, the calibration sequence might be:

1. Zero power sensor and meter.
2. Calibrate power sensor with 1 mW, 50 MHz.
3. Calibrate system signal generator against the power sensor to 18 GHz (using stored frequency response).
4. Switch the signal generator to the calibration path and calibrate all system detection instruments such as the counter, spectrum analyzer, and, in fact, the power meter to re-check its system switching. This checks effectively at the UUT panel. At the highest frequencies, some path loss corrections will be needed.
5. Switch the power sensor to the calibration path and calibrate all system stimulus instruments, including a re-check of the generator and its switching.
6. Switch both the signal generator and power sensor back to system use, and test with confidence.

Well, all this looks relatively simple and automatic, albeit somewhat expensive, due to the large number of switches in a moderate-size matrix. And for modest accuracies, it is quite straightforward. The very highest accuracies would require more complex calibration routines, probably using roll-up power sensors right at the UUT panel. Such routines are a user decision because only the user knows the final requirements. And, luckily, the entire set of paths is not likely to need the highest accuracy.

On the other hand the total number of individual switches affects the effective lifetime calculations. HP 33311B Switches are specified for repeatability of 0.03 dB at 1 million switch operations. A matrix of 25 switches, then, would obviously have a shorter life, but not simply 1 million divided by 25. The user would instead look at his/her test sequence and predict the switch actions of each intersection to find the critical high-use paths and, in turn, the expected MTBF.

Incidentally, one useful flexibility of such a matrix of Figure 28 is that the user could design a spare switch rank to be available for alternate use when a high-usage rank fails. And the calibration and test path strategies above will help monitor how the various paths are doing day-by-day. As usual, then, the designers must use their best ingenuity to achieve the optimum balance of cost, life and performance.

AUTOMATED SWITCH CONTROLLER FOR HP-IB USE

The recommended controller for all HP 33311B, HP 33311B-C04 and HP 33311B-C05 Switches is HP's 11713A Switch/Driver. (See Figure 37.) It can control as many as 10 of the switches and provides both the solenoid dc drive power and the HP-IB interface for automated programmability. The operator can also use lighted front-panel pushbuttons to energize any coax switch manually. Note that the 5 x 4 matrix example of Figure 28 requires only two controllers.

Incidentally, the standard HP 11713A Switch/Driver can also operate two of the older HP 8761B SPDT Coax Switches, and a special modification is available which can run up to a total of 10 HP 8761B Switches.

The HP 11713A Driver offers convenient configuration for ATE system designers as well as the confidence of a predesigned attention to arc-suppression protection diodes, and an included power supply. Furthermore, if the system signal interface box requires a programmable step attenuator for signal level control, such as the HP 33320-series Attenuators, the HP 11713A Attenuator/Switch Driver handles them directly.

Finally, the HP 33311B Switch family can be programmed by other HP-IB relay drivers such as the HP 3488A, 3497A, 6940B, or 6942A. In those cases an external 24 Vdc power supply is required. One advantage of the above modular "card-cage" type instruments is that they may already be specified for other ATE relay control or LF/RF switching. In that case adding another relay-control card and power supply could permit actuation of RF and microwave switching.

References

- [1] Adam, et al, *Broadband Passive Components for Microwave Network Analysis*, HP Journal, January 1969.
- [2] Kirkpatrick, et al, *Coaxial Components and Accessories for Broadband Operation to 26.5 GHz*, HP Journal, June 1977.
- [3] Minck, *High Performance Matrix Switching Arrangement Gives Flexibility to ATE System Designers*, MSN, May 1983, pp. 162-168.
- [4] HP Application Note 328-1, *Practical Test System Signal Switching*.

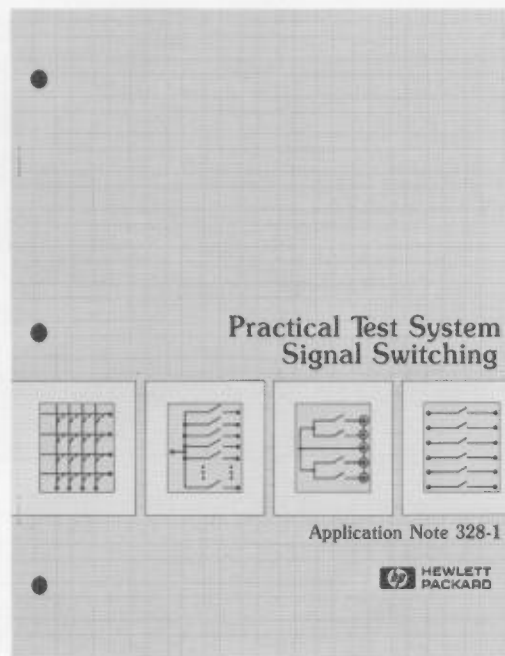

HP's Application Note 328-1 provides a detailed look at system switching with sections on measurement basics, switching topologies maintaining signal integrity, and switching configurations. It addresses mostly low frequency & RF applications.

